

SIEMENS-ALLIS

Installation • Operation • Maintenance

Instructions

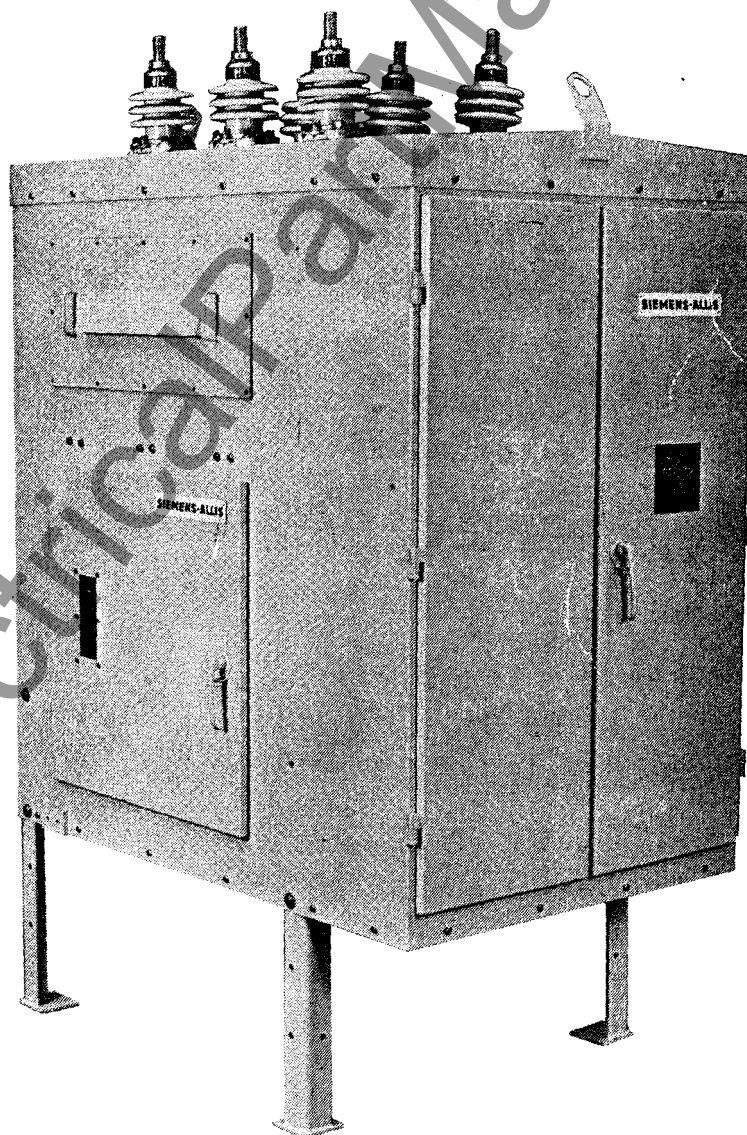

SDV
Power Circuit
Breaker
PB 3718

www.ElectricalPartManuals.com

CONTENTS

ILLUSTRATIONS

Figure 1	Lifting Vacuum Breaker	2
Figure 2	Section through A Vacuum Interrupter	5
Figure 3	SDV Circuit Breaker	7
Figure 4	Section through the 3AF Interrupting Unit	8
Figure 5a	Section through the 3AF Breaker in the Open Position	9
Figure 5b	Section through the 3AF Breaker in the Closed Position	9
Figure 6	3AF in the Closed Position With the Closing and Tripping Springs Charged	10
Figure 7	3AF in the Closed Position (Tripping Spring Charged and Latched)	11
Figure 8	Breaker Shaft in the Open Position	11
Figure 9	Closing Assembly With Slack Closing Spring	12
Figure 10	Lower Pole Support With Insulated Coupler	15
Figure 11	Procedure to Check Vacuum	15
Figure 12	Procedure to Check Vacuum	15
Figure 13	Control Scheme for 3AF Operator	16
Figure 14	Complete Closing Sequence	18
Figure 15	Complete Tripping Sequence	19
Figure 16	Complete Anti-Pump Sequence	19
Figure 17	Type Q-10 Auxiliary Switch	20
Figure 18	Location of Trip Latch Adjustment Screw	21
Figure 19	Closing Latch Measurement	21
Figure 20	Contact Travel Measurement	22
Figure 21	Contact Pressure Spring Measurement	22
Figure 22	Contact Erosion Check	23
Figure 23	Procedure to Tighten Terminal Clamp	26
Figure 24	Points to be Lubricated	27
Figure 25	Typical Breaker Bushing	28

www.ElectricalPartManuals.com

CONTENTS

TABLE OF CONTENTS

General		Electrical Control	
Introduction	1	Typical Schematic	1
Qualified Person	1	Spring Charging	1
Description	2	Closing	1
Receiving	2	Tripping	1
Storage	2	Reclosing	1
		Complete Closing Sequence	1
Technical Data		Complete Tripping Sequence	1
Dielectric Data	3	Complete Anti-Pump Sequence	1
Electrical Data	3		
Mechanical Data	4	Adjustments	
Control Data	4	General	2
Arc-Quenching Medium	5	Circuit Breaker Timing	2
		Auxiliary Switch	2
Description		Trip Latch Adjustment	2
General	6	Close Latch Adjustment	2
High Voltage	6	Motor Cut-Off and Anti-Pump Control Switch	2
Operator Mechanism Compartment	6	Vacuum Interrupter Stroke Adjustment	2
Control and Relay Compartment	6	Contact Pressure Spring Adjustment	2
Interrupting Unit	8	Contact Erosion Adjustment	2
Switching Operation	9		
Operating Mechanism	10	Maintenance	
Opening	10	General	2
Closing	10	Inspection Schedule	2
Charging	12	Contact Erosion	2
		Interrupter Vacuum	2
Installation		Hydraulic Shock Absorber	2
Shipment and Storage	13	Interrupter Replacement	2
Location	13	Re-lubricating	2
Primary Lead Connections	13	Special Tools	2
Ground Connection	13	Replacement Parts	2
Secondary and Control Wiring	13	Bushing & Stand-Off Insulators	2
Final Installing Inspection	13	Bushing Current Transformers	2
		Relay Panel	2

The information in this manual is intended to assist operating personnel by providing information on the general characteristics of equipment of this type. It does not relieve the user of responsibility to use sound engineering practices in the installation, application, operation and maintenance of the particular equipment purchased.

If drawings or other supplementary instructions for specific applications are forwarded with the manual or separately, they take precedence over any conflicting or incomplete information in this manual.

www.ElectricalPartManuals.com

DIMENSIONS

Throughout this manual, metric values, when used, are shown as (XXX).

INTRODUCTION

Siemens-Allis outdoor circuit breakers are precision built devices designed to function efficiently under normal operating conditions. They are designed and manufactured to operate within the ANSI C37 standards applicable to the breaker rating.

The successful field performance of these breakers depends as much on proper installation and maintenance as it does on good design and careful manufacture. Refer to these sections before performing any installation or maintenance.

Factory adjustments are carefully made and the breaker is given rigorous mechanical tests after which the adjustments are re-checked. All control wiring is given a 1500 volt withstand test. The current transformers are manufactured and tested according to the ANSI C57.13 standards.

The instructions included in this book are to aid you in obtaining longer and more economical service from your Siemens-Allis circuit breakers. For proper installation and operation — resulting in better service and lower maintenance costs — this information should be distributed to your operators and engineers.

By carefully following these instructions, difficulties should be avoided. However, they are not intended to cover all details or variations that may be encountered in connection with the installation, operation and maintenance of this equipment.

Should additional information be desired, including replacement instruction books, contact your Siemens-Allis representative.



Distinctive signal words (DANGER, WARNING, CAUTION) are used in this instruction book to indicate degrees of

hazard that may be encountered by the user. These signal words are defined below.

DANGER Indicates death, severe personal injury or substantial property damage **will** result if proper precautions are not taken.

WARNING Indicates death, severe personal injury or substantial property damage **can** result if proper precautions are not taken.

CAUTION Indicates minor personal injury or property damage **could** result if proper precautions are not taken.

 DANGER	
	Power circuit breakers are applied at high voltages and have mechanical parts which move at high speeds.
	To avoid injuries due to electrical shock, burns, and entanglement in moving parts, this equipment must be installed, operated and maintained only by qualified persons thoroughly familiar with equipment instruction manual and drawings.

QUALIFIED PERSON

For the purpose of this manual, a qualified person is one who is familiar with the installation, construction and operation of the equipment, and the hazards involved. In addition, he has the following qualifications:

- a) Is trained and authorized to energize, de-energize, clear, ground, and tag circuits and equipment in accordance with established safety practices.
- b) Is trained in the proper care and use of protective equipment such as rubber gloves, hard hat, safety glasses or face shields, flash clothing, etc., in accordance with established safety practices.
- c) Is trained in first aid.

www.ElectricalPartManuals.com

GENERAL

Page 2

DESCRIPTION

The type SDV circuit breaker is a three phase distribution type outdoor unit for service on systems at 15.5kV maximum voltage. The breaker is equipped with a trip-free stored energy operating mechanism and one vacuum interrupter per phase. This breaker offers dependable overload protection to connected equipment and lines. It should be installed only in circuits where it will operate within the range given on the breaker nameplate.

The physical arrangement of the circuit breaker comprises a high voltage compartment, an operator compartment, a relay and control power compartment and adjustable legs.

Current transformers are usually furnished with the circuit breaker. The standard breaker includes three current transformers, however, two standard type transformers can be supplied per bushing for a total of twelve transformers per breaker.

RECEIVING

The type SDV circuit breaker is transported from the factory completely assembled and tested, and is carefully inspected and packed. The breaker is shipped with the contacts open, and both the closing spring and tripping springs are discharged.

Immediately upon receipt of a breaker, an examination should be made for evidence of any damage that may have occurred during shipment. If any damage or indication of rough handling is evident, immediately file a damage claim with the transportation company and notify the nearest Siemens-Allis representative.

NOTE Damage claims must be processed within the time period specified by the carrier. Siemens-Allis cannot be held responsible for shipping damage, either external or internal, if the inspection is not made and claim forwarded within the set time limit.

Check the vacuum breaker against the shipping list and keep all identification tags and the instruction book so they are available. A pocket has been provided inside the control power compartment door that contains the instruction book and the schematic and connection diagrams. Retain

all records and identification data since this must accompany any later inquiry concerning the breaker.

Unload breaker by use of sling and lifting lugs or with lift when breaker is shipped on skid. Lifting lugs are provided on each side of the breaker so that the unit may be lifted by use of a sling and hooks of the proper size. (Refer to the breaker nameplate for weight.)

See Figure 1 for lifting of breaker with sling.

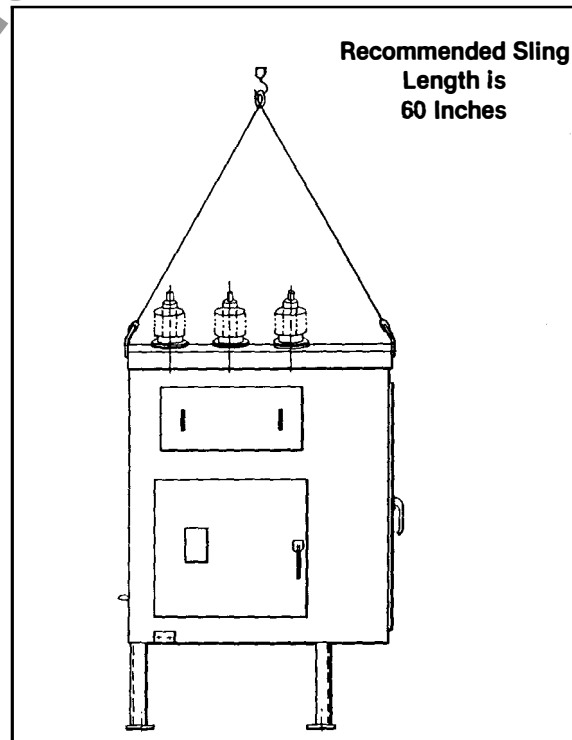

Figure 1. Lifting Vacuum Breaker

STORAGE

If the breaker is not to be connected in service immediately it should be set on an adequate foundation, such as permanent foundation, and the internal parts kept dry. The compartment heaters or other space heaters should be maintained to maintain the inside temperature of the breaker over ambient. Prolonged outdoor storage without heaters will result in corrosion of internal parts. In any event, it is recommended that the breaker receive periodic inspection during storage.

www.ElectricalPartManuals.com

TECHNICAL DATA

DIELECTRIC DATA

The SDV-15 is a three-pole circuit breaker of outdoor design and uses the arc extinguishing ability of a vacuum to interrupt an arc.

The values of insulation level compiled in table 2 are referred to sea level in accordance with ANSI C37.04-1979 consolidated standards. The higher the site altitude, the lower the insulating capacity of the air. The decrease in insulating capacity is neglected by standards for altitudes of up to 1000m above sea level. For higher altitudes, the values of power-frequency withstand voltage, lightning impulse withstand voltage and rated continuous current must be corrected in accordance with table 1.

Table 1
Altitude Correction Factors, k

Altitude		Rated Maximum Voltage and Insulation Level	Rated Continuous Current
ft	(m)		
3300	(1000)	1.00	1.00
5000	(1500)	0.95	0.99
10 000	(3000)	0.80	0.96

NOTE: Interpolated correction factors shall be used in determining factors for intermediate altitudes.

Withstand test voltages apply to altitudes up to 1000 m above sea level. If a breaker is to be installed at a higher altitude, the appropriate test voltage and continuous current rating must be applied by a correction factor k (Table 1).

Table 2
Dielectric Ratings

Rated Voltage	kV	15.5
Rated power frequency withstand voltage (kV rms) at 60 Hz	kV	50
Rated lightning withstand voltage (1.2/50 μ s)	kV max.	110
Chopped wave 2 μ s } Chopped wave 3 μ s } Breaker In Closed Position Only	kV	142
	kV	126
Bushing creepage distance Standard	in.	11
Hi Creep	in.	17

ELECTRICAL DATA

Temperature range - 30... + 40 Degrees C

Rated max. voltage	kV	15.5
Rated frequency	Hz	60
Rated continuous current	A	See Nameplate
Rated short-circuit current	kA	See Nameplate
Transient recovery voltage under terminal fault conditions	—	As Per ANSI
Rated making current	kA	1.6 x Rated short-circuit breaking current
Rated duration of short-circuit	S	3
Rated duty cycle		0-0.3S-CO-15S-CO-15S-CO-15S-CO

www.ElectricalPartManuals.com

TECHNICAL DATA

Page 4

MECHANICAL DATA

Operating Times			Interrupter Units		
Minimum command duration	cycles	3	Number per pole		1
Closing time	cycles	5.0	Travel of contact	in.	.62
Opening time	cycles	1.9	Clearance between open contacts	in.	.62
Arcing time at 60 Hz	cycles	1	Breaker Weights		
Interrupting time at 60 Hz	cycles	3			
			Breaker, complete without relay package	1bs (kg)	1600 (725)

CONTROL DATA

Tripping and Closing Coils							
Rated voltage	V d.c. ①	48	125	250	V a.c. ①	115	230
Tripping coil	A	8.2	5.4	2.0	A	5.0	1.9
Closing coil	A	2.0	1.0	.5	A	.9	.4

① Voltage Range is in accordance with ANSI

Auxiliary Switch

Type	3SV9Z	
Maximum rated voltage	V d.c.	500
Rated normal current	A	10
Making current	A	30
Breaking Capacity	Ohmic Load a.c. or d.c.	2200W
	Ind. Load at 220V d.c.	200W

Motor

Rated voltage	V d.c. ①	48	125	250	V a.c. ①	115	230
Continuous current	A	6.0	2.5	1.5	A	4.5	2.5
Charging time	Sec	10.0	7.8	8.0	Sec	8.3	8.6

① Voltage Range is in accordance with ANSI

Heaters

Operating mechanism compartment	W	200 ①
Control and relay compartment	W	100

① Thermostat controlled

TERMINALS

Permissible conductor tension per connecting joint appl in any direction static + dynamic 100 LBS

www.ElectricalPartManuals.com

ARC-QUENCHING MEDIUM VACUUM

Vacuum Interrupter

The basic construction of the interrupter can be seen from Figure 2. The moving contact 36 moves in guide 35. The metal bellows 34 follows the travel of the moving contact and seals the interrupter against the surrounding atmosphere.

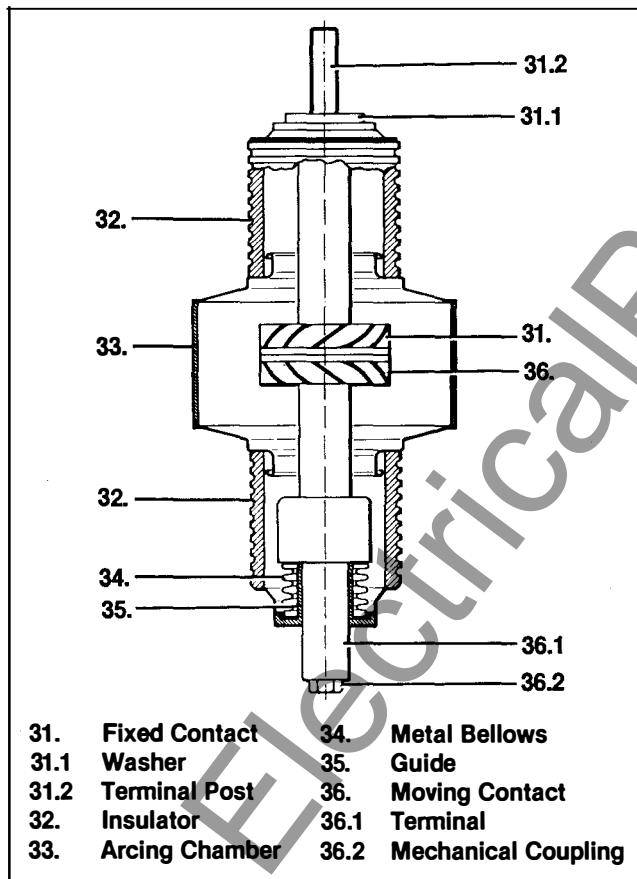

Figure 2. Section through a Vacuum Interrupter

The Arc-quenching Principle

When the contacts separate, the current to be interrupted initiates a metal vapor arc discharge and flows through this plasma until the next current zero. The arc is then extinguished and the conductive metal vapor condenses on the metal surfaces within a matter of microseconds. As a result, the dielectric strength in the break builds up very rapidly.

The contacts are designed so that the self-generated field causes the arc to travel. This prevents localized overheating when interrupting large currents.

The metal vapor arc discharge can only be maintained if a certain minimum current flows. A current that does not attain this level is chopped prior to current zero. This chopping current must be kept to a minimum in order to prevent unduly high overvoltages building up when inductive circuits are switched. The use of a special contact material ensures that current chopping is limited to 4-5A.

The rapid build-up of the dielectric strength in the break enables the arc to be safely extinguished even if contact separation occurs immediately prior to current zero.

The arc drawn in the vacuum breaker is not cooled. The metal vapor plasma is highly conductive and the resulting arc voltage only attains values between 20-200V. For this reason and because of the short arcing times, the arc energy developed in the break is very small. This also accounts for the long electrical life expectancy of the vacuum interrupter.

Owing to the high vacuum (less than 10^{-9} bar) in the interrupter, contact clearances of only about 6 to 20 mm are needed in order to attain a high dielectric strength.

www.ElectricalPartManuals.com

DESCRIPTION



Page 6



GENERAL

A SDV circuit breaker, rated 15.5kV is shown in Figure 3. The breaker consists of four main sections: the high voltage compartment, the operator mechanism compartment, the control and relay compartment, and adjustable legs.

HIGH VOLTAGE COMPARTMENT

The high voltage compartment supports six entrance bushings, and encloses the bushing current transformers, three vacuum interrupters supported by six stand-off insulators, current carrying bus bars and various current connections and operating linkage assemblies. It consists of a corrosion resistant water tight enclosure with isolating phase barriers between phases and a dead front to the operating compartment and the control and relay compartment. The bushing mounting surface is sloped to provide for positive run-off of water. Moisture control is provided by means of warm air flow from the heated operator compartment and a special condensation adsorption and desorption coating applied to the inside roof surface. Each of the interrupters is operated through its own push rod assembly from the main operating shaft in the operator compartment. A hinged door is provided for ease in accessibility and maintenance. Two removable access covers are also provided for ease in accessibility and maintenance.

 WARNING	
	Hazardous voltages exists within this compartment that can cause personal injury, death or damage to the circuit breaker.
	This compartment must not be opened until you have de-energized the high voltage, grounded all terminals and turned off control power.

 CAUTION	
	The vacuum interrupters within the compartment can emit harmful x-ray radiation when a low frequency withstand test is performed.
	To eliminate this hazard the low frequency withstand test must be performed with all covers on and doors closed.

OPERATOR MECHANISM COMPARTMENT

The operator compartment consists of a separate weather-proof compartment isolated from the high voltage compartment by a dead front barrier. It contains the energy operating mechanism, the external trip "69" switch, manual trip and manual close buttons, position counter, open-close position indicator, close condition indicator and moisture control heater w/ thermostat. A hinged door is provided with window for operations counter, open-close position indicator and spring charge-discharge condition.

CONTROL AND RELAY COMPARTMENT

The control and relay compartment consists of a weather-proof compartment isolated from the high voltage compartment by a dead front barrier. It contains the terminal terminals for the bushing current transformer, power cut-off devices and customer wiring terminals. It contains a swing out relay panel when required.

Adjustable Legs:

The breaker is equipped with four adjustable legs to the breaker cabinet at each corner and serve to anchor the breaker to the foundation. The legs are adjustable in increments with heights to live parts of 82 inches to 118 inches.

www.ElectricalPartManuals.com

DESCRIPTION

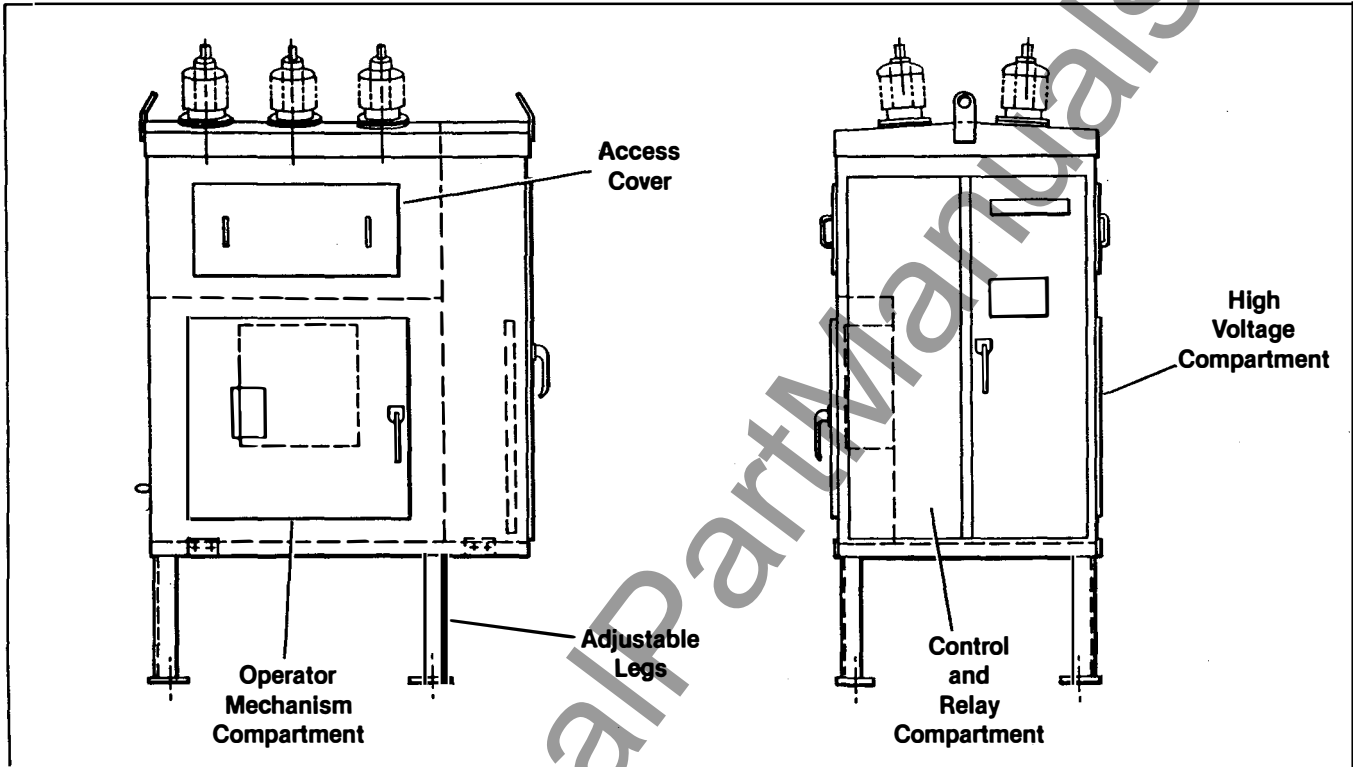

Figure 3. SDV Circuit Breaker Rated 15.5kV

www.ElectricalPartManuals.com

www.ElectricalPartManuals.com

DESCRIPTION

Page 8

INTERRUPTING UNIT

Figure 4 shows a section through an interrupter unit. The vacuum interrupter 30 is rigidly fixed to the upper terminal 27 and pole support 20 by its fixed terminal post 31.2. The lower ceramic part of the interrupter is stabilized against lateral forces by a centering ring 28.1 on pole support 40. The external forces due to switching operations and the contact pressure are absorbed by the braces 28.

The current flows from the upper terminal 27 through the fixed contact terminal washer (Figure 2 items 31.1), contact (Figure 2 item 31) the movable contact (Figure 2 item 36) the movable contact terminal post (Figure 2 item 36.1), which is connected with the lower terminal 29 through the terminal clamp 29.2, and flexible strap 29.1.

The vacuum interrupter becomes open by the movable contact (Figure 2 item 36) moving in guide (Figure 2 item 36.2). The metal bellows (Figure 2 item 34) follows the movement of the moving contact and seals the interrupter against the surrounding atmosphere.

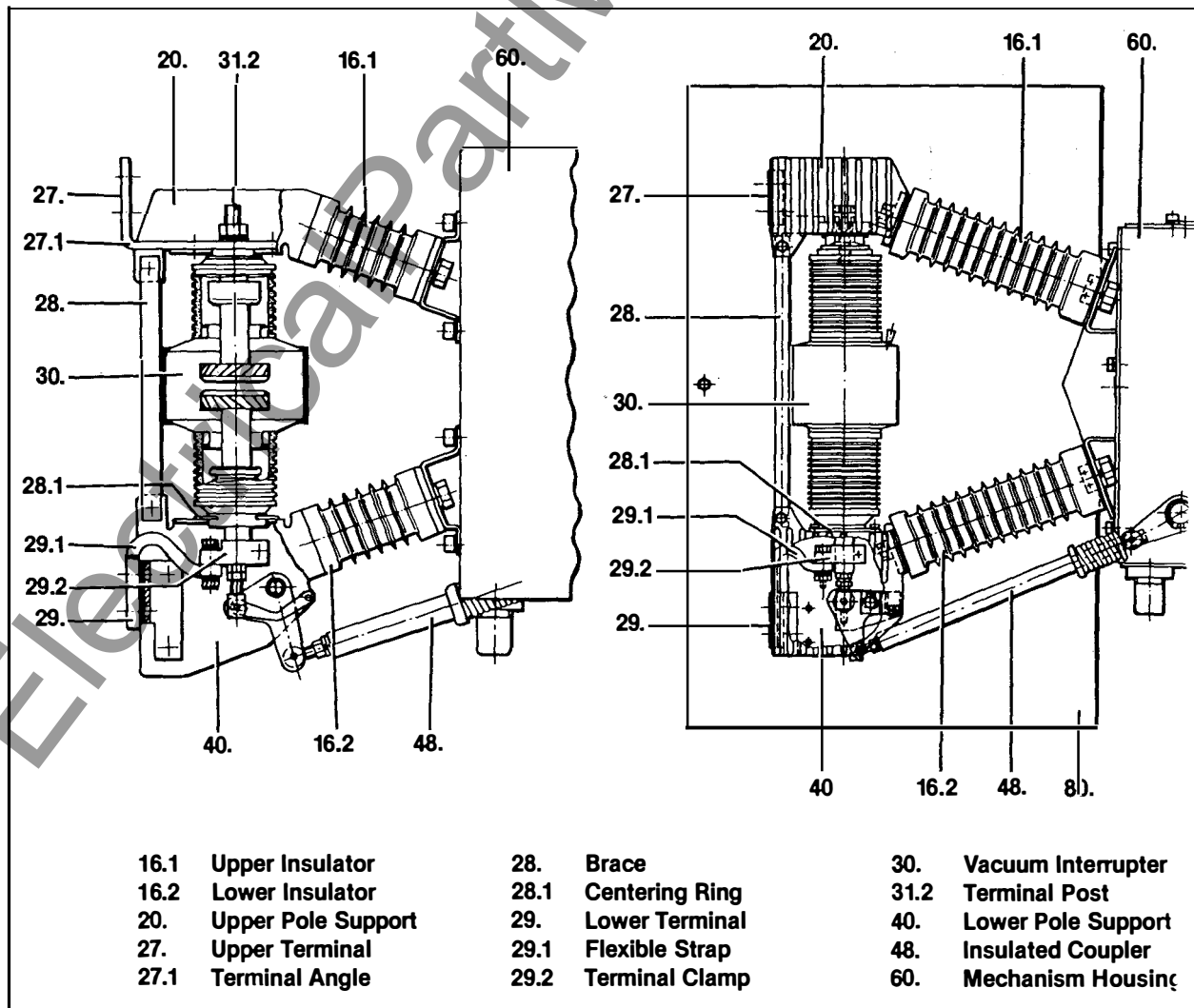

Figure 4. Section through the 3AF Interrupting Unit

www.ElectricalPartManuals.com

DESCRIPTION

SWITCHING OPERATION

When a closing command is initiated the closing spring, which was previously charged by hand or by the motor, actuates the moving contact 36 through breaker shaft 63, lever 63.7, insulated coupler 48 and lever 48.6.

The forces that may occur when the action of the insulated coupler is converted into the vertical action of the moving contact are absorbed by drive link 48.9 which pivots on pole support 40 and adapter 36.3.

During closing, the tripping spring and the contact pressure spring 49 are charged and latched by pawl 64.2.

The closing spring is recharged by the motor immediately after closing.

In the closed state, the necessary contact pressure is established by the contact pressure spring and the atmospheric pressure. The contact pressure spring automatically compensates for the arc erosion, which is very small.

When a tripping command is given, the energy stored in the tripping and contact pressure springs is released by pawl 64.2. The opening operation is similar to the closing operation. The residual force of the tripping spring arrests the moving contact 36 in the open position.

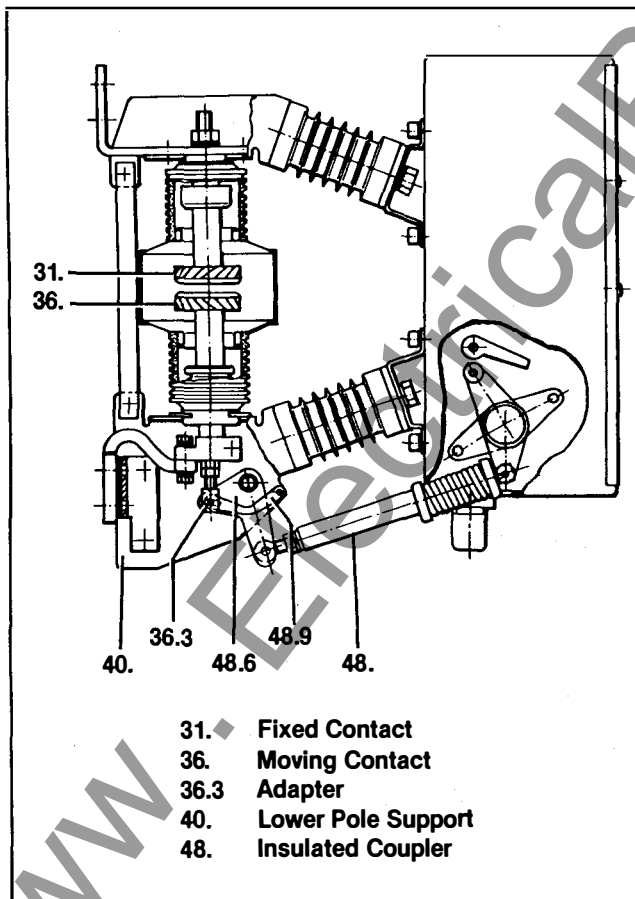

Figure 5a. Section through the 3AF Breaker in the Open Position.

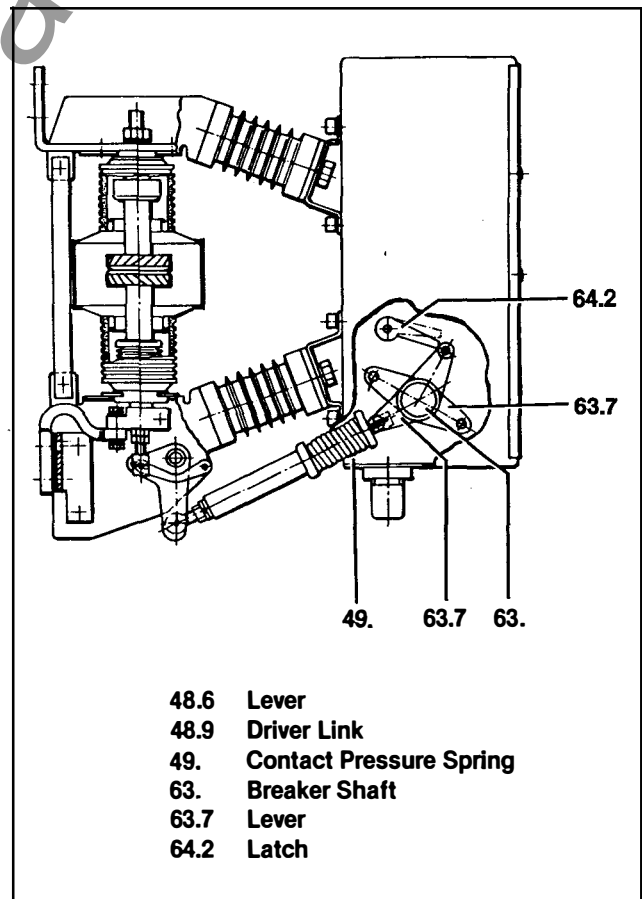

Figure 5b. Section through the 3AF Breaker in the Closed Position.

www.ElectricalPartManuals.com

DESCRIPTION

Page 10

OPERATING MECHANISM

The 3AF operating mechanism is equipped with motor, spring-charging mechanism, shafts, closing and tripping springs, ON/OFF indicator, charged/discharged indicator for the closing spring, auxiliary switch, close/open solenoid, voltage plug, operation counter and required cut-off switches.

The essential parts of the 3AF mechanisms are shown in Figure 6.

OPENING

(See Figures 6, 7 & 8)

When opening the breaker by hand, the spring is released by pressing the trip button 54. In the case of an electrical command being given, the tripping solenoid 52T (54.1) unlatches the tripping spring. The tripping spring turns the breaker shaft 63 via lever 63.5 the sequence being similar to that for closing.

CLOSING

(See Figures 6, 7, 8 & 9)

When the breaker is closed by hand, the spring is charged by pressing CLOSE button 53. In the case of the closing solenoid 52SRC (53.1) unlatches the closing spring.

As the closing spring relaxes, the charging mechanism is turned by crank 62.2. The cam disc 62.3 at the end of the charging shaft actuates the drive lever 62.4. The result is that breaker shaft 63 is turned by lever 63.1 and the closing rod 62.8. At the same time, the levers 63.2 and 63.3 fixed on the breaker shaft operate the tripping couplers for the breaker poles. Lever 63.4 operates the OPEN/CLOSE indicator over to closed. Lever 63.5 operates the tripping spring 64 during closing, and lever 63.6 is latched in the closed position by lever 64.3 and by pawl 64.2. Lever 63.1 actuates the auxiliary switch 68 through the linkage 68.1.

The crank 62.2 on the charging shaft moves the closing spring by acting on the control lever 55.2. The "Spring

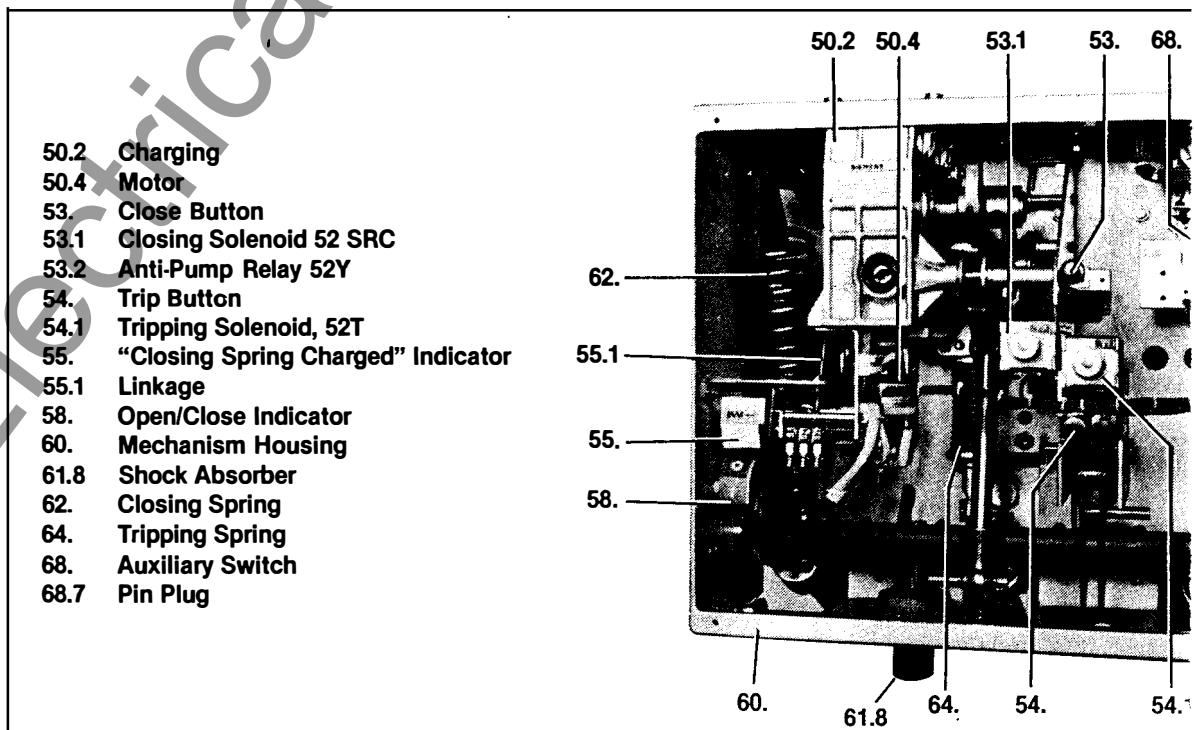

Figure 6. 3AF in the Closed Position with the Closing and Tripping Springs Charged.

www.ElectricalPartManuals.com

DESCRIPTION

dication is thus cancelled. The limit switches 50.4.1 switch in the control supply are actuated to the effect that the closing spring is recharged immediately.

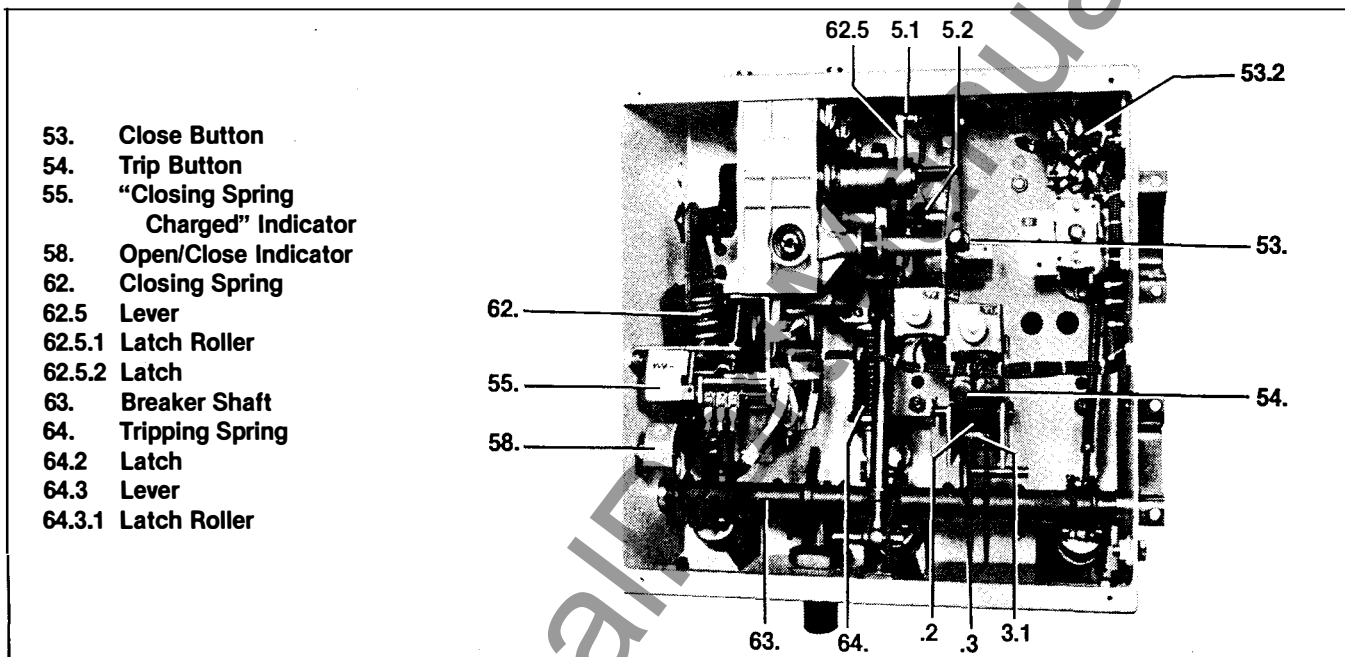

Figure 7. 3AF in Closed Position (Tripping Spring Charged and Latched)

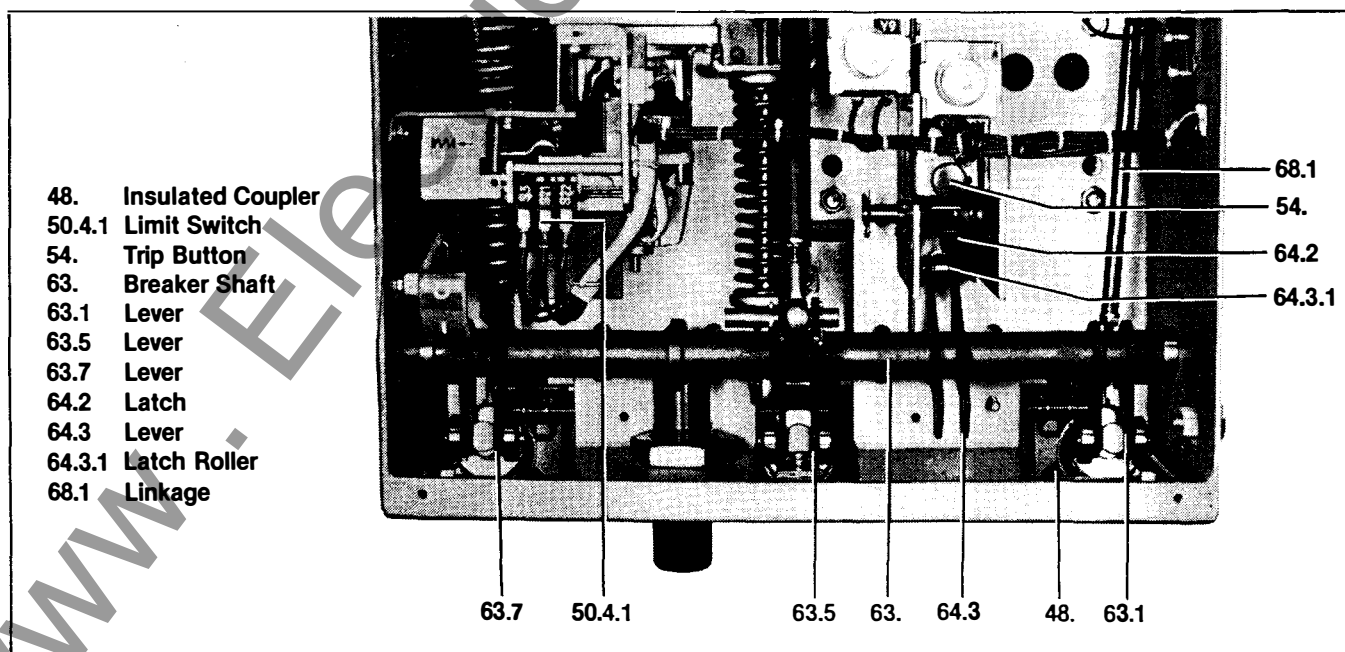

Figure 8. Breaker Shaft in the OPEN Position

www.ElectricalPartManuals.com

DESCRIPTION

Page 12

CHARGING

(See Figures 7, 8 & 9)

The charging shaft 62.1 is supported in the charging mechanism 50.2 but is not coupled mechanically with the charging mechanism. Fitted to it are the crank 62.2 at one end and the cam 62.3 together with lever 62.5 at the other.

When the charging mechanism is actuated by hand or by a

motor, the flange 50.3 turns until the drive 50.3.1 reaches the cutaway part of cam disc 62.3, thus causing the charging shaft to follow. The crank 62.2 charges the spring 62. When this has been fully tensioned, the cam disc 62.3 rotates the linkage 55.1 for the "Closing spring charge indicator 55 via control lever 55.2 and also the limit switch 50.4.1 for interrupting the motor supply. At the same time the lever 62.5 at the other end of the charging shaft is brought into position for closing.

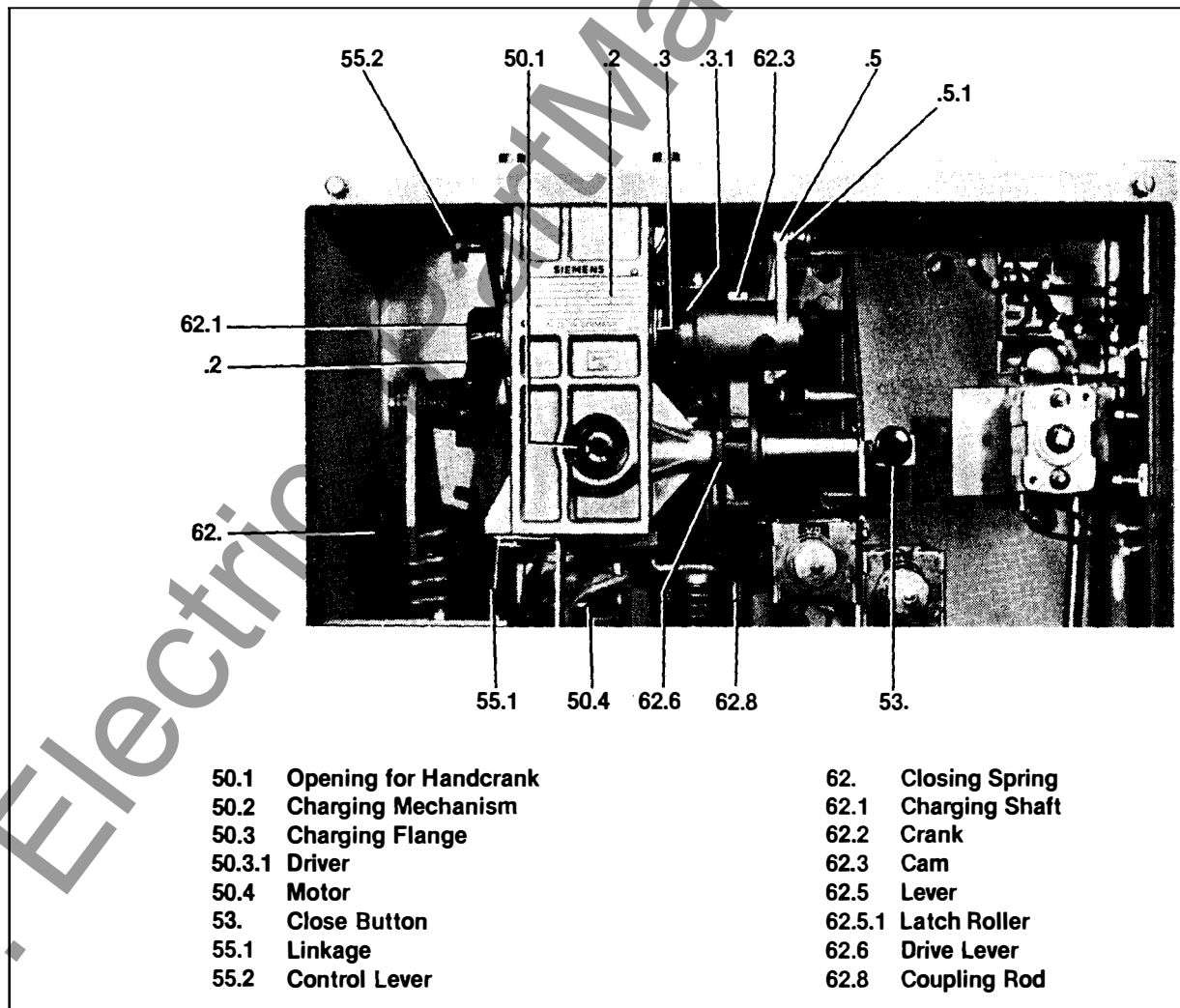

Figure 9. Closing Assembly with Slack Closing Spring

www.ElectricalPartManuals.com



SHIPMENT AND STORAGE

Shipping and storage considerations were described in the GENERAL section of this manual. They should be reviewed again at the time of installation. The breaker should be checked again to ensure that all parts are proper. Review lifting instructions (Figure 1).

LOCATION

The breaker should be located so that it is readily accessible for manual operation and inspection, and it has ample clearance to other apparatus or structures. It is advisable to provide a cement pad into which are imbedded suitable foundation bolts. The foundation should be reasonably level and it is recommended that .75 inch diameter anchor bolts be used.

Place the breaker on the foundation, and tighten the hold down bolts. The breaker must be level but no special leveling procedures are required. The breaker is adjustable in height for flexibility and to meet the various electrical codes. While the breaker is being lifted into position, adjust the leg extensions per the specific height requirement. After the breaker has been secured on the foundation, the electrical connections can be made to the de-energized lines.

 DANGER	
	The breaker is shipped at the minimum height position and the customer must adjust the breaker height to insure compliance with safety codes for electrical clearance.

The breaker is shipped in the open position with all springs discharged. No blocking is used to prevent closing or tripping.

PRIMARY LEAD CONNECTIONS

The primary leads should be brought down from above the breaker if possible, with adequate clearance to other parts, and with the proper supports so that the breaker bushings are not subjected to excessive strains. They should be sized to have a capacity at least equal to the maximum operating current of the circuit and within the rating of the breaker. Connections are to be made to the bolted terminals of the bushings and must be securely tightened to a clean bright surface to assure good contact.

GROUND CONNECTION

Diagonally opposite grounding pads are provided for connecting the mounting frame to ground using at least a 4/0 awg conductor. A good low resistance ground is essential for adequate protection.

SECONDARY AND CONTROL WIRING

A conduit panel opening is provided in the bottom of the relay and control power compartment for the connection of the control circuits. The control wires should be run separately from high voltage wiring to prevent inductive coupling between them and should be sized for full operating current to avoid a drop in voltage below that specified on the nameplate. All conduits should be sealed off at their entrance to the relay and control power compartment.

Terminal blocks are provided inside the relay and control power compartment for the connections necessary for the control wiring, bushing current transformers and relay panel when provided. Connection diagrams are supplied with each breaker to show the proper connections. These diagrams will be found in the pocket provided on the inside of the left hand door for this compartment.

FINAL INSTALLING INSPECTION

1. Make sure that the breaker is properly set up and level on its foundation.

www.ElectricalPartManuals.com



INSTALLATION

2. Make a check for the tightness of all hardware on the cabinet, adjustable legs, bushings, bus bars and operating mechanism.
3. See that all bearing surfaces of the operating and breaker mechanism have been lubricated.
4. Inspect all insulated wiring to see that it has not been damaged, and test for possible grounds or short circuits.
5. See that all covers, doors and bolted connectors are securely fastened.
6. Retouch any paint that has been damaged during installation.
7. Check to see that all mechanisms are free of any packing and operate freely.

 CAUTION
The breaker is shipped with styrofoam bracing between the phase barriers. The bracing is inside the high voltage compartment and must be moved. Failure to remove this bracing before the bushings are energized will result in damage to the breaker.

8. Examine the vacuum interrupter envelopes for damage, and wipe them and other insulating parts with a clean dry cloth.
9. Charge the closing spring manually and push the manual close to close the breaker.
10. Observe the open-close position indicator and operation counter for operation with a manual open.
11. Energize the control circuits. The motor-gear unit should run to charge the closing spring then turn-off.
12. Close the circuit breaker electrically and verify that the breaker is closed and remains closed by checking the mechanical position indicator. Note that the motor-gear unit will immediately run to charge the closing spring.



13. Trip the breaker electrically.
14. Repeat the close and trip operations several times.
15. Check the tripping and closing times from closure to contact break or make.
16. Hi-pot each vacuum interrupter while in the open position, to verify that damage has not occurred during shipment. The voltage should be raised gradually. The contact gap should sustain 27kV, 60Hz, 1 minute, or 38kV DC for 1 minute. If it does not, the interrupter is faulty and must be replaced.

 CAUTION	
	The vacuum interrupters within this compartment can emit harmful x-ray radiation when a low frequency withstand test is performed. To eliminate this hazard the low frequency withstand test must be performed with all covers on and doors closed.

Observe the following items when hi-potting vacuum interrupters.

- A) Do not hi-pot the interrupters at voltages higher than listed.
- B) Test personnel should remain at least 6 feet (183 cm) away from the interrupter being tested.
- C) Tests should be performed with normal metal panels installed, and test personnel should position themselves to take advantage of the shielding provided by the metallic barriers.
- D) The circuit breaker bushings and metallic midbus on the interrupter may retain a static charge after the hi-pot test, so discharge with a grounded probe before handling.

www.ElectricalPartManuals.com

 DANGER	
	<p>Do not open the high voltage compartment for maintenance until you have de-energized the high voltage, grounded the entrance bushings and turned off control voltage. Personal injury, death or damage to circuit breaker can result.</p>

NOTE With respect to X-radiation: (No hazardous X-radiation is produced with closed contacts or with open contacts with rated operating voltage applied to them.)

17. An alternate method to check the vacuum interrupters for vacuum is as follows:

A) Isolate and open the breaker then detach the insulated coupler 48 from lever 48.6. See Figure 11.

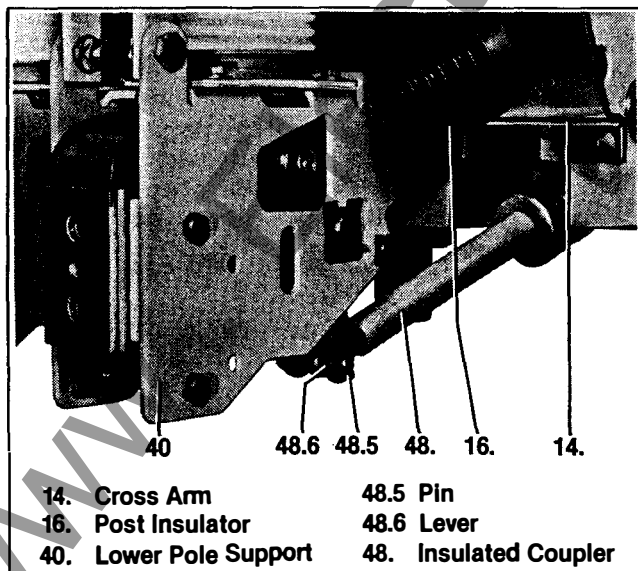

Figure 10. Lower Pole Support with Insulated Coupler

B) The atmosphere pressure will force the moving contact of a hermetically sealed interrupter into the closed position, causing lever 48.6 to move into the position shown in Figure 11. An interrupter that has lost its vacuum will not move closed after being forced open.

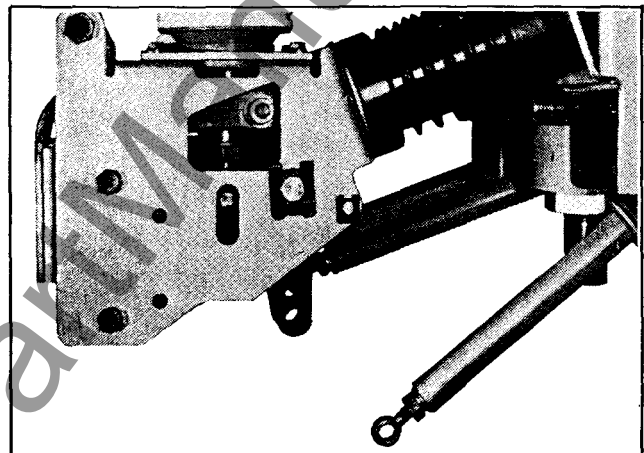

Figure 11. Procedure to Check Vacuum

C) A vacuum interrupter may be assumed to be intact if it shows the following characteristics:

An applicable closing force has to be overcome when lever 48.6 is moved to the open position by hand. See Figure 12. When the lever is released, it must automatically return to the closed position and the contacts must be heard to close.

After checking the vacuum, refit the lever 48.6 to the insulated coupler 48.

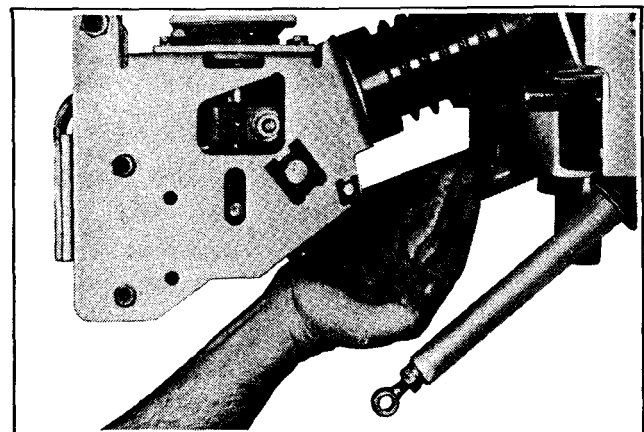

Figure 12. Procedure to Check Vacuum

18. The vacuum breaker is now ready for normal operation.

www.ElectricalPartManuals.com

ELECTRICAL CONTROL

TYPICAL SCHEMATIC

The controls for the SDV breaker are mounted in the 3AF mechanism housing. The controls consist of the motor cut-off switch 50.4.1 (Figure 8), anti-pump relay directly below

the pin plug 68.7 (Figure 6) auxiliary switch 68 (Figure 6) the close lockout switch directly behind the manual button.

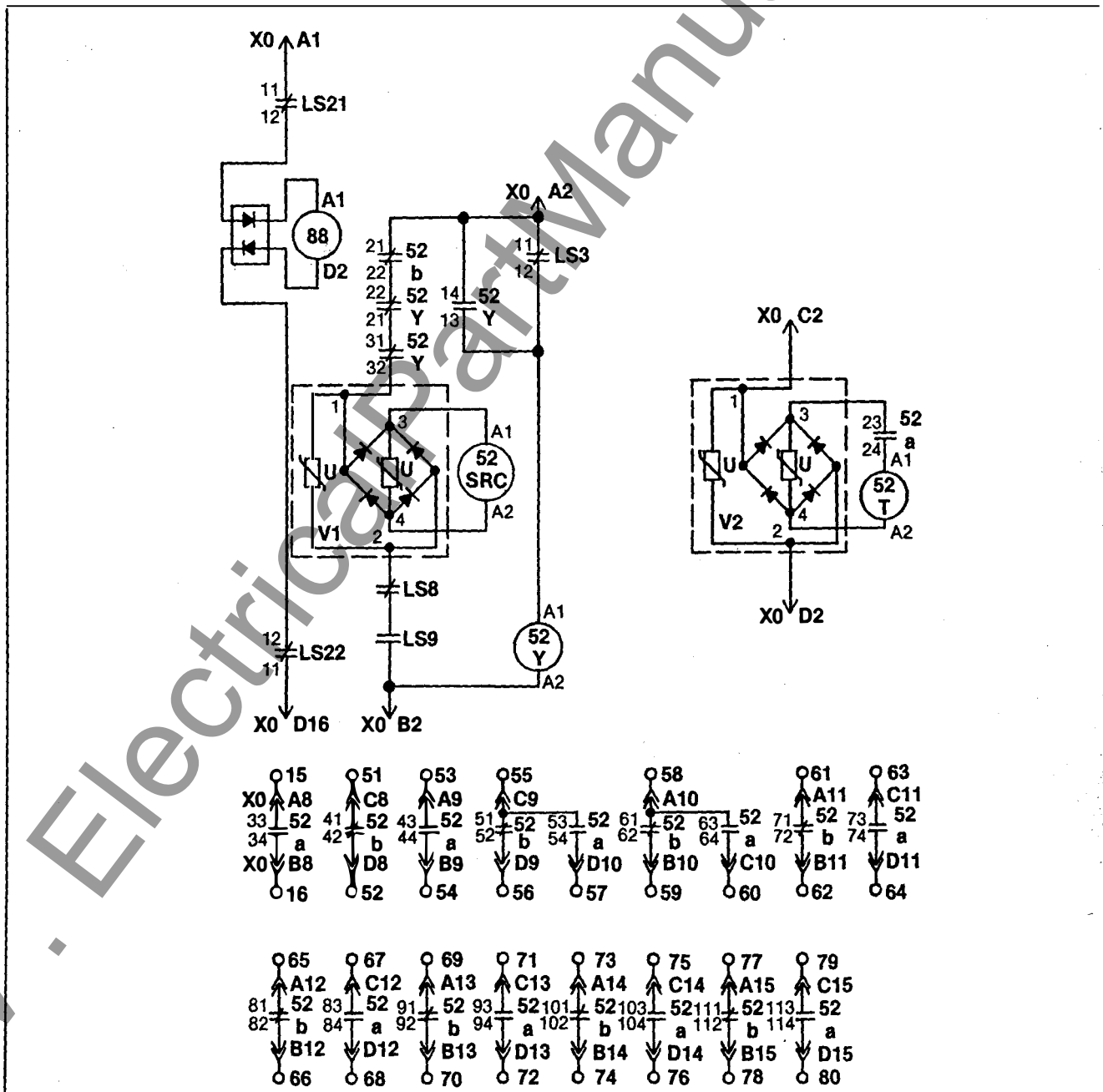

Figure 13. Control Scheme for 3AF Operator

www.ElectricalPartManuals.com

SPRING CHARGING

The spring charging power is supplied through plug terminals A1 and D16 (Figure 13). The LS21 and LS22 switches are shown with the closing springs discharged. When the control is energized, the motor 88 starts to charge the springs. The LS21 and LS22 switches are operated by control lever 55.2 (Figure 9) mounted on the charging mechanism 50.2 (Figure 9). The charging shaft revolves to the position of applying full tension, dead center, to the springs. Beyond this position the LS21 and LS22 switches are actuated and the motor is cutoff.

CLOSING

When the close command is given, the circuit from plug terminal A2 through 52b, two sets of 52y contacts, LS8, LS9 to plug terminal B2 energizes the closing coil 52 SRC.

As soon as the closing springs are discharged the LS3 switch contact closes to energize the 52Y relay. If the close control switch remains closed, the 52Y relay remains picked up through contact 52Y. The control switch has to be released to reset the close circuit for another closing operation. This forms the anti-pumping relay circuit which prevents the circuit breaker from reclosing immediately after a trip-free operation. If control power is momentarily lost during closing, upon re-energization, the 52Y relay picks up instantaneously through contact LS3 maintaining the anti-pumping relay circuit prior to complete spring charging.

TRIPPING

When the trip switch is closed the circuit from plug terminal C2 through 52a to plug terminal D2 energizes the trip coil 52T.

RECLOSING

The closing spring is recharged automatically as described above. Therefore, when the breaker is closed both its springs are charged (the closing spring charges the tripping spring during closing). As a result, the breaker is capable of an O-t-CO operating cycle (dead time "t" is 0.3 seconds).

www.ElectricalPartManuals.com

ELECTRICAL CONTROL

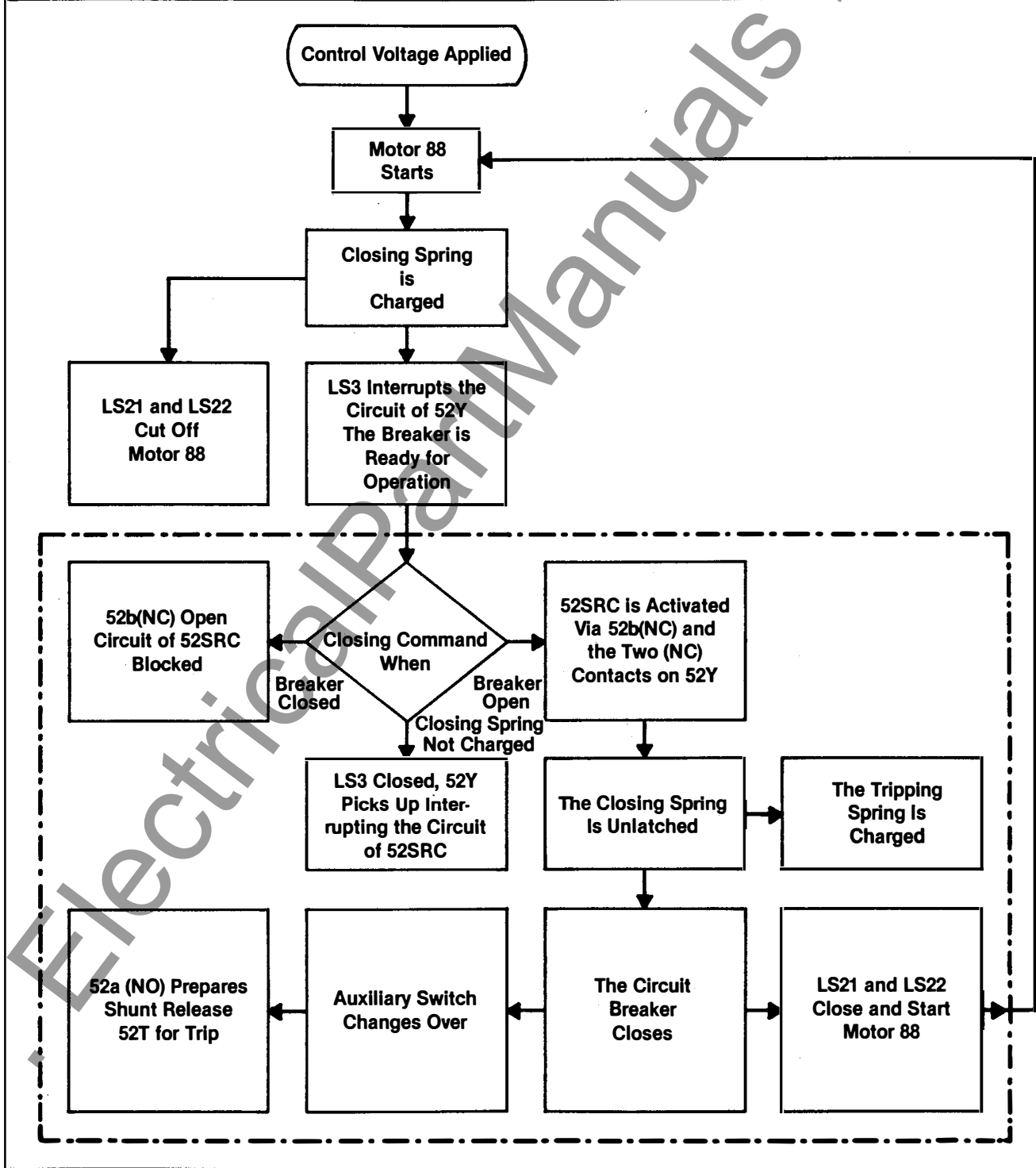

Figure 14. Complete Closing Sequence

www.ElectricalPartManuals.com

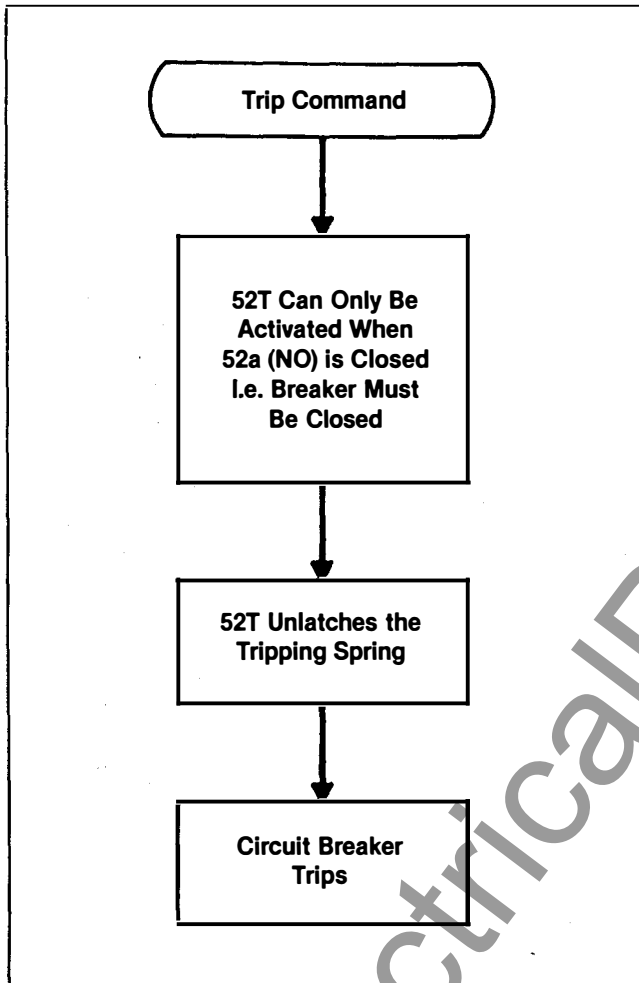

Figure 15. Complete Tripping Sequence

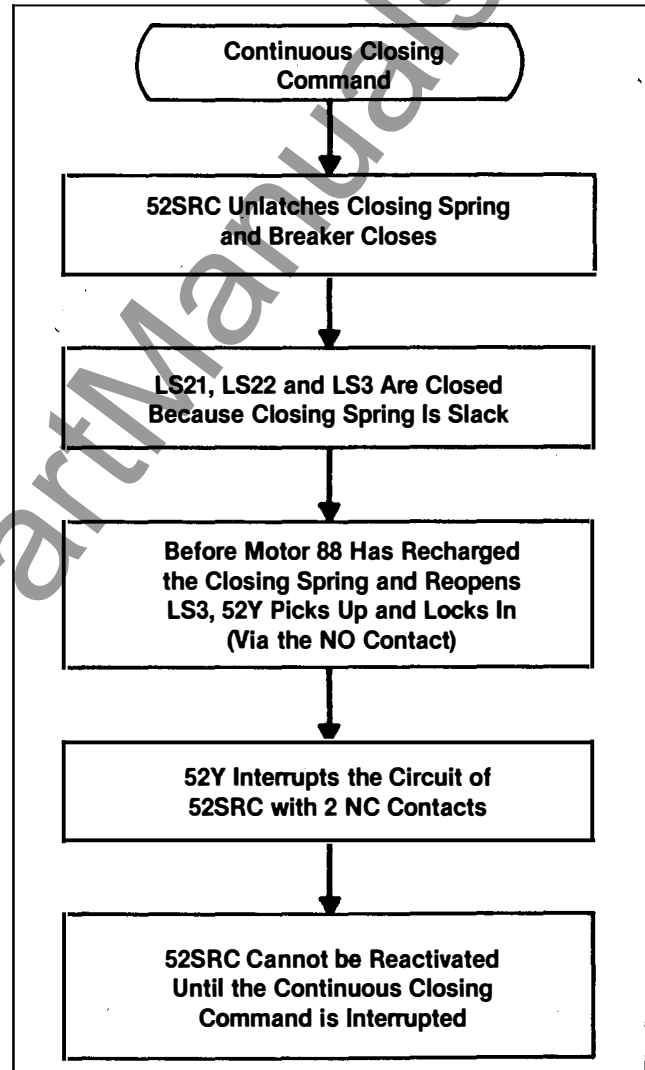

Figure 16. Complete Anti-Pump Sequence

www.ElectricalPartManuals.com

ADJUSTMENTS

Page 20

GENERAL

Adjustable items are factory set and checked before and after numerous mechanical operation on every breaker to insure correctness. No adjustment checking should be necessary on new breakers. If a malfunction occurs, check for hidden shipping damage.

The following will help you make the correct adjustments when replacing a broken or worn part.

CIRCUIT BREAKER TIMING

A comparison of circuit breaker timing at any period of maintenance with that taken when the breaker was new will indicate the operational condition of the breaker mechanism.

Closing Time	83 ms*
Spring Charging Time	15 s
Opening Time	32 ms*

*The value applies to the normal control voltage value.

Closing Time = The time from instant of command initiation until contacts are closed in all three poles.

Opening Time = The time from instant of command initiation until the contacts open in all three poles.

AUXILIARY SWITCH

The breaker is equipped with a 22 stage auxiliary switch which 11 stages are 52a contacts and 11 stages are 52b contacts. However, only 10 stages of each are used. Nine of the 52a stages are available for customer use and one is used within the operator for the trip circuit. Nine of the 52b stages are also available for customer use and one is used within the operator for the close circuit. The remaining 52a and 52b stage is normally not used and reserved for operator when a special control function is required. The auxiliary switch also has an impulse contact that closes during an open or close operation for 10 ms. The impulse contact is normally not wired.

The individual contacts of the switch can not be adjusted. The only adjustment is to change the length of the switch's coupling rod which will effect the ON and OFF position of all switch stages. The switch need only be adjusted such that the contacts are operated before the limit positions of the breaker. The coupling rod length is changed by the adjustment screw at the lower end.

As a special feature the breaker can be fitted with a type Q-10 auxiliary switch with (10) stages. Each stage can be adjusted to be an 52a contact or 52b contact. Refer to figure 18 for features of this switch.

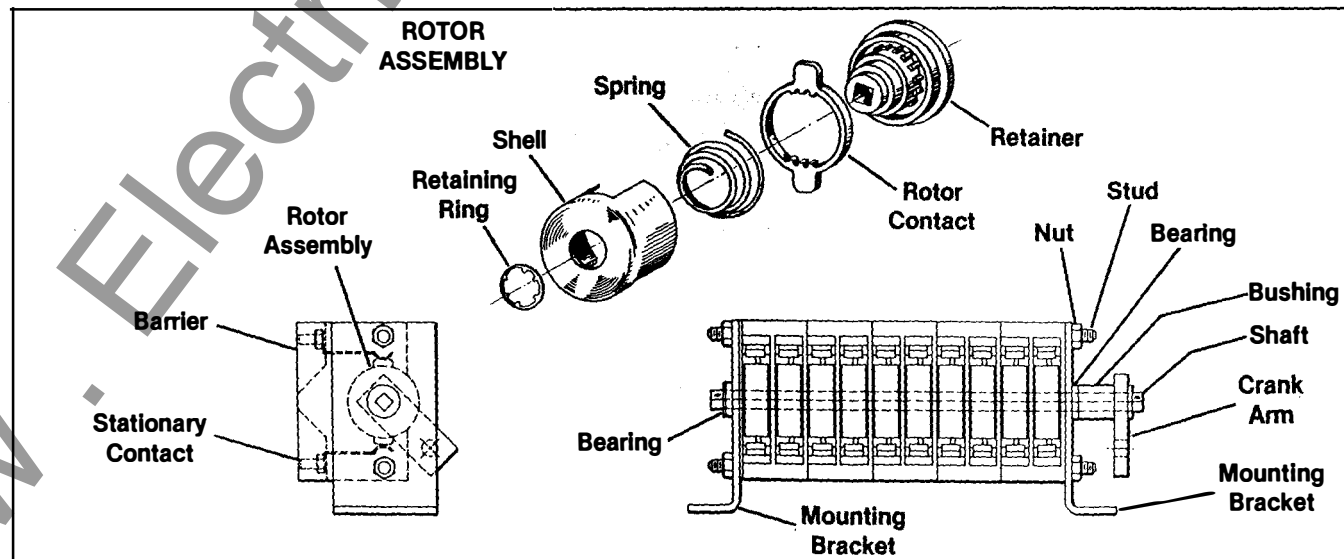

Figure 17. Type Q-10 Auxiliary Switch

www.ElectricalPartManuals.com

TRIP LATCH ADJUSTMENT

(See Figure 18)

Apply steady pressure to the armature of the opening solenoid 54.1, (Figure 6). The trip latch should release the opening spring before the limit position of the armature is reached. The armature should have a free travel of .39 to .6 inch (10 to 15mm) before picking up the load of the trip latch. The armature stroke can be reduced by screwing in the adjustment screw and increased by screwing in the same adjustment screw. Secure the final adjustment by means of the lock nut. See Figure 18 for location of adjustment screw.

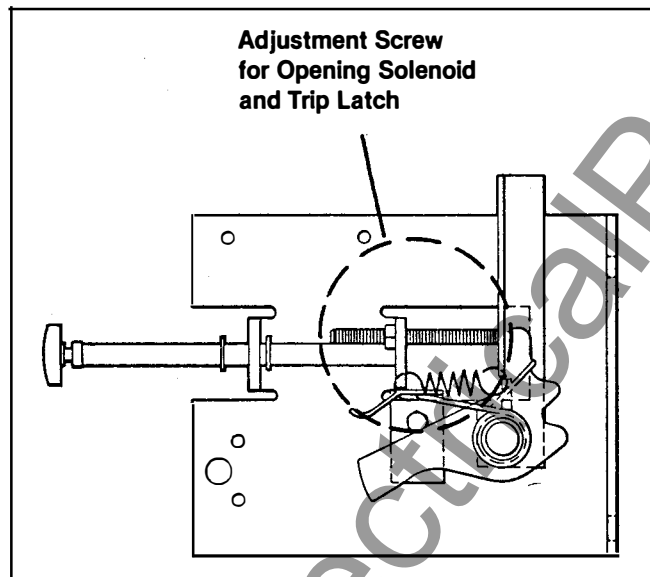

Figure 18. Location of Trip Latch Adjustment Screw

CLOSE LATCH ADJUSTMENT

(See Figure 19)

Apply steady pressure to the armature of the closing solenoid 53.1, (Figure 7). The close latch should release the closing spring before the limit position of the armature is reached. The armature should have a free travel of .39 to .6 in (10 to 15mm) before picking up the load of the close latch. The close armature is not adjusted, however, the travel of

the closing cam support roller on the closing latch can be checked. The support roller on the closing latch should have an overlap of .31 in (8mm). See Figure 8, item 62.5.1 and item 62.5.2.

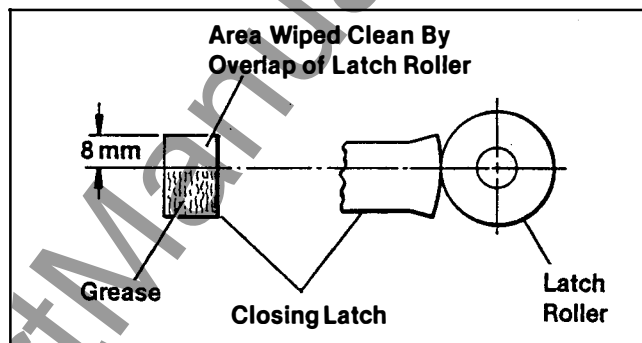

Figure 19. Closing Latch Measurement

MOTOR CUT-OFF & ANTI PUMP CONTROL SWITCHES

The control lever that actuates the motor cut-off and anti-pump control switches is adjusted at the factory and should not require field adjustment. This same lever operates the Spring Charged—Spring Discharged indicator. However, adjustment of the actuation of these devices can be made by bending the metal tab on the control lever 55.2, (Figure 9) up or down.

VACUUM INTERRUPTER STROKE ADJUSTMENT

The final adjustment of the interrupter stroke must be made only after the interrupter has been operated a number of times no-load to set the interrupter's contacts. The standard number of open-close operations for a new interrupter is 300. Only after the mechanical operations should the interrupter stroke be set at .62 in +0 - .039 (16mm + 0 - 1mm).

New breakers will be shipped with a minimum of 300 mechanical operations logged on the operator and the stroke adjustment made. Replacement interrupters will be supplied with 300 mechanical operations to set the contacts.

www.ElectricalPartManuals.com

ADJUSTMENTS

Page 22

Step #1 Set breaker in the open position with opening and closing springs discharged. Remove all electrical power from breaker controls.

Step #2 Remove the coupling rod 48 from lever 48.6 by removing pin 48.5. See Figure 10. The interrupter should rapidly close under the influence of the ambient air pressure. When the interrupter is closed the contact erosion mark must be fully visible. See Figure 22.

Step #3 Measure and record the dimension "X₁" as shown in Figure 20.

Step #4 Press the lever 48.6 back to the open position and reinsert pin 48.5. Note that the pin can be reinserted in the hole it was removed from as the remaining holes have been burred to not permit use.

Step #5 Measure and record dimension "X₂" as shown in figure 20. The difference between X₁ and X₂ is interrupter stroke.

Step #6 Should the interrupter stroke not be within $.62 \text{ in } +0 - .039$, the eye bolt on the end of coupling rod can be screwed "in" to increase "out" to decrease the interrupter's stroke. Tighten the locknut on the eye bolt after any adjustment.

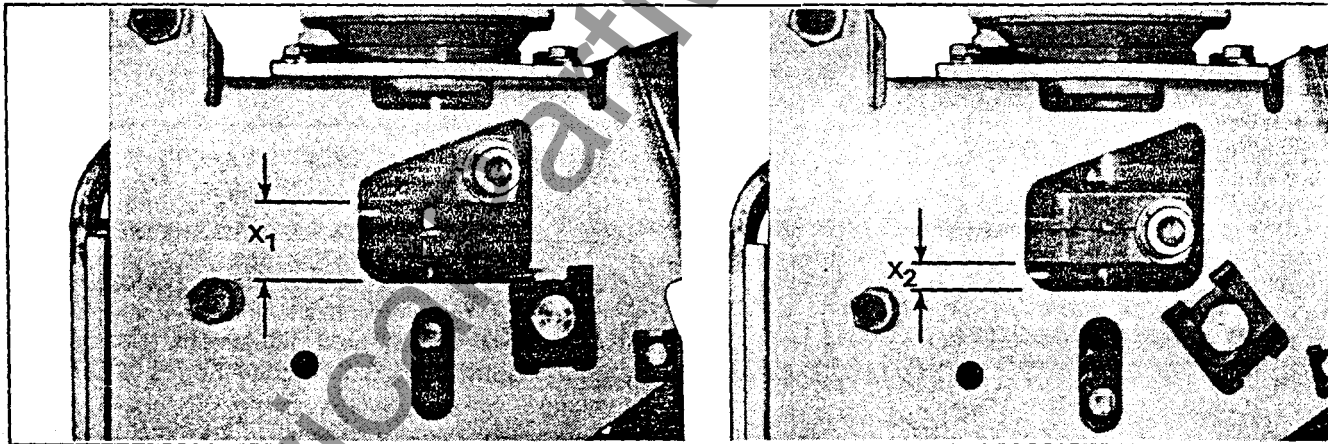

Figure 20. Contact Measurements Travel

CONTACT PRESSURE SPRING ADJUSTMENT

The stroke of the contact pressure spring is the difference in the length of the spring when the breaker is closed and opened. The pressure spring stroke should be .17 to .30 inch.

Step #1 Set breaker in the open position and measure the length of the contact pressure spring for each interrupter. Record this dimension as "Y₁", see Figure 21.

Step #2 Set breaker in the closed position and measure the length of the spring. Record this dimension as "Y₂".

Step #3 The stroke of the contact pressure spring is the difference between Y₁ and Y₂. A contact pressure spring adjustment on one phase should not be required because changing one requires changing

the rotation of the operator shaft and then phases will be changed.

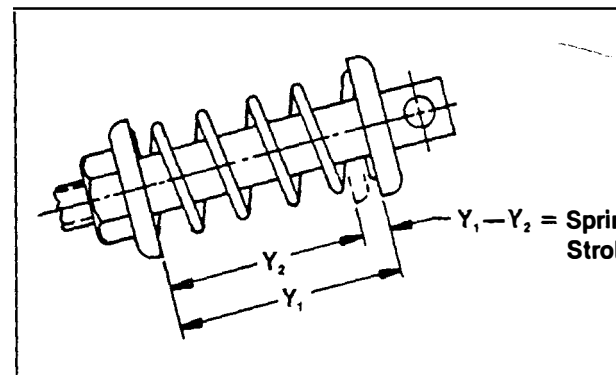

Figure 21. Contact Pressure Spring Measurement

www.ElectricalPartManuals.com

ADJUSTMENTS

CONTACT EROSION ADJUSTMENT

The vacuum breaker must be accessible from the back to observe the white check mark. The position of the white check mark "A" on the vacuum interrupter indicates the vacuum interrupter is still within permissible limits, when the contacts are closed. Should the mark not be seen, then the interrupter should be replaced. Intermediate adjustment is not recommended.

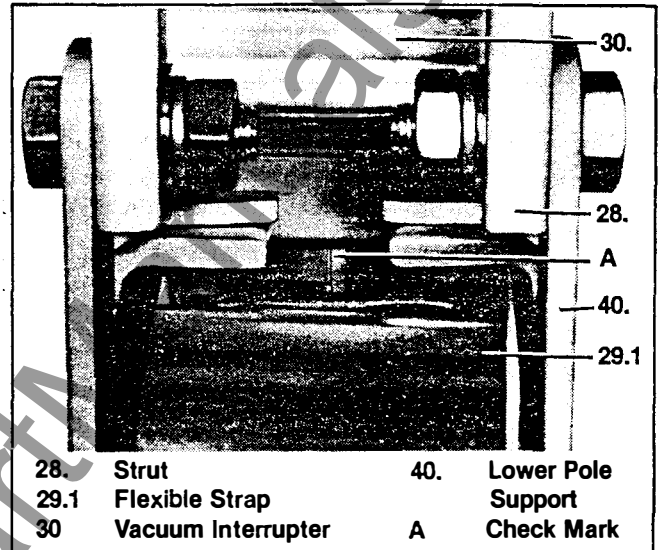

Figure 22. Contact Erosion Check

ADJUSTMENT SUMMARY

	Setting	Adjustment
Circuit Breaker Timing: Closing Time Spring Charging Time Opening Time	83 ms 15s 32 ms	None None None
Auxiliary Switch: Type 3SV9Z (Part of Operator)	52a 52b	Individual contacts not adjustable. Switch's coupling rod length changed to effect "ON" and "OFF" position of all stage
Type Q-10 (Special Feature)	52a 52b	Individual contacts adjustable in 15 degrees increments
Close Latch	.31 in.	None
Motor Cut-Off Switch	Open with spring charged. Close with spring discharged	Bend tab on control lever
Vacuum Interrupter Stroke	.62 in. + 0 - .039	Coupling rod length
Contact Pressure Spring	.17 to .30 in.	None
Contact Erosion	Observation of erosion mark	None

www.ElectricalPartManuals.com



MAINTENANCE



Page 24

GENERAL

Thorough, periodic inspection is important to satisfactory operation. Inspection and maintenance frequency depends on installation, site, weather and atmospheric conditions, experience of operating personnel and special operation requirements. Because of this, a well-planned and effective maintenance program depend largely on experience and practice.

Prior to performing any maintenance work, make certain all control circuits are open, and that the breaker has been completely isolated from the system.

 DANGER	
	Hazardous Voltage and Mechanisms. Will cause personal injury, death or damage circuit breaker.
	This equipment should be installed, operated and maintained only by qualified persons thoroughly familiar with equipment - INSTRUCTION MANUALS and drawings.

 DANGER	
	Hazardous Voltage. Will cause personal injury, death or damage circuit breaker.
	Do not touch or service until you have: de-energized high voltage, grounded all terminals and turned off control voltage.

Always inspect a breaker which has interrupted fault current.

All current carrying joints should be inspected to be sure contact surfaces are free of protrusions or loose h

INSPECTION SCHEDULE

Once a year, a general visual inspection must be made out and, if necessary, the outer insulating parts cleaned down.

Breaker Mechanism: The operating mechanism must be oiled and lubricated every 10 years or after 10,000 close operations.

Vacuum Interrupters: The life expectancy (number of close operations) of the interrupters is a function of breaking current. They must be replaced after a certain number of mechanical operations or when the contacts have reached by the maximum amount.

CONTACT EROSION

A visual check of the erosion mark "A", see Figure 6, on the movable member of the vacuum interrupter will indicate the contact erosion. The contact wear is still within the permissible limits as long as this mark can be seen when the contacts are closed.

INTERRUPTER VACUUM

A hi-pot test should be applied to the open interrupter contacts of each phase.

An alternate method to check the vacuum within the interrupters is to observe if atmospheric pressure will force the moving contact shut.

HYDRAULIC SHOCK ABSORBER

The 3AF mechanism is equipped with a hydraulic shock absorber and a stop bar that functions when the breaker opens. See item 61.8 Figure 6. The shock absorber

www.ElectricalPartManuals.com

require no adjustment. However, at maintenance checks, the shock absorber should be examined for evidence of leaking. If evidence of fluid leakage is found, the shock absorber must be replaced to prevent damage to the vacuum interrupter bellows.

INTERRUPTER REPLACEMENT

Replacement interrupters are furnished as a complete assembly. They have been completely tested and dielectrically and mechanically conditioned. The interrupters, when installed, do not require that they be operated no-load a set number of times or voltage tested to condition the contacts.

Before starting any work the breaker should be isolated, short-circuited and grounded. Disconnect the auxiliary supply and open and close the breaker by hand until both springs have been discharged.

It is recommended that one interrupter be removed and replaced completely rather than removing two or more interrupters at a time. The following is a step-by-step procedure for exchanging an interrupter.

1.0 Removing an Interrupter

(Figures 4, 5a, 5b & 10)

- 1.1 Loosen the bolt on terminal clamp 29.2.
- 1.2 Remove pin 48.5 from insulated coupler 48 and levers 48.6.
- 1.3 Remove the pin from adapter 36.3.
- 1.4 Remove the bolts on struts 28 at the upper pole support 20.
- 1.5 Remove the centering ring 28.1.
- 1.6 Remove the large bolt of pole support 20 at insulator 16.1.
- 1.7 Lift off the complete pole support 20 together with the vacuum interrupter 30.
- 1.8 Remove the nut on terminal post 31.2 and detach the vacuum interrupter 30 from the pole support 20.

Installing an Interrupter

(Figures 2, 4, 5a, 5b & 10)

NOTE The replacement interrupter will be equipped with adapter 36.3 that has been adjusted at the factory. Do not alter the adapter setting.

- 2.1 All copper contact-making surfaces should be conditioned before assembly. This is done by rubbing the surfaces vigorously with criss-crossing strokes until bright metal shows. Wipe off any metal dust with a clean rag, apply a film of acid-free vaseline to the surface and then bolt them together immediately. Make sure that the steel brush employed is used only for copper. The silverplated surfaces must be wiped off with a clean rag only and not wire brushed.
- 2.2 Position the vacuum interrupter 30 in the pole support 20 with the evacuation nipple on the center section of the interrupter facing the mechanism housing 60. Then screw the nut (complete with flat washer and lock washer) on to terminal post 31.2 finger-tight.
- 2.3 Insert vacuum interrupter 30 together with the upper pole support 20 in the lower support 40. Slip the terminal clamp 29.2 into position and screw pole support 20 on the post insulator 16.1, making a finger-tight joint.
- 2.4 Refit the struts 28 to pole support 20 without tightening the screws.
- 2.5 Couple levers 48.6 and drive links 48.9 to adapter 36.3 using the pin supplied with the interrupter.
- 2.6 Push terminal clamp 29.2 against the locking ring on the moving terminal 36.1 and position interrupter 30 so that its groove faces the connecting surface of flexible strap 29.1. Tighten the bolt of terminal clamp 29.2 with a torque of 40 Nm, taking care to see that the copper terminal of the interrupter is not subjected to an undo bending moment. This is achieved by tightening the bolt in the manner shown in Figure 23. Use a corresponding wrench to hold the nut.
- 2.7 Align pole support 20 correctly and tighten the bolt on insulator 16.1 and those on struts 28.

www.ElectricalPartManuals.com

- 2.8 Tighten the nut on terminal post 31.2, holding the vacuum interrupter firmly and operate levers 48.6 by hand to see whether the moving contact of the interrupter moves freely. If need be, undo the nut on terminal post 31.2 and adjust the interrupter in pole support 20 by turning and moving it slightly.
- 2.9 Press centering ring 28.1 against the interrupter neck and bolt on.
- 2.10 Link insulated coupler 48 and lever 48.6 together by means of pin 48.5 and lock the pin in position.
- 2.11 Open and close the breaker several times no-load and then check to see that all the screwed joints are tight.

- 3.4 Press the lever 48.6 back to the open position, reinsert pin 48.5 and repeat the above measurements. Note that the pin can be only reinserted in the hole was removed from.
- 3.5 Determine the difference between the dimension taken in steps 3.3 and 3.4. The stroke must be between .59 to .62 inches [15 to 16mm]. The setting can be adjusted by altering the setting of the eyebolt of the insulated coupler 48. If the stroke is excessively turn the eyebolt out and if it is too short, turn the eyebolt in. Recheck the stroke after each adjustment.

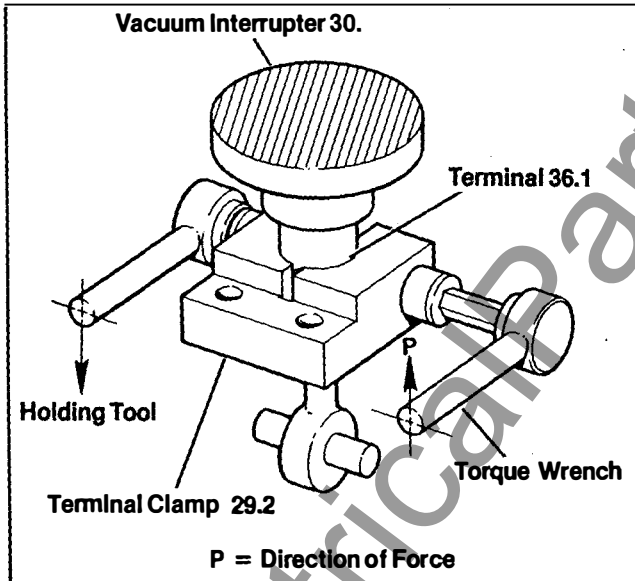

Figure 23. Procedure to Tighten Terminal Clamp

3.0 Checking the Contact Stroke

- 3.1 Trip the breaker.
- 3.2 Remove pin 48.5 as described in step 2 under adjustments. The interrupter contacts must now close automatically.
- 3.3 Measure the distance between the lower edge of the lateral cutout in pole support 40, and the lower edge of terminal clamp 29.2, using Vernier calipers.

RE-LUBRICATING

The main points to be lubricated with Centplex 24D (Siemens-Allis number W-962-020) are all bearings and sliding surfaces indicated in figure 24. All points not marked (bearings, articulated joints and auxiliary switch) should be treated with Ritzol corrosion protection agent 7/2 (Siemens-Allis number 00-337-507-051).

To relubricate the mechanism, detach its cover. Lubricate all the appropriate points, starting at the top left and working through systematically. Parts that are not rigidly fixed should be moved slightly to and fro to let the oil penetrate. Following this, operate the breaker several times to test it.

SPECIAL TOOLS

In addition to the usual maintenance tools required for breaker maintenance there are two special devices available. One is a hand crank to manually charge the closing spring and the other is a hand lever to manually slow close the breaker. These devices are listed and can be obtained from the factory.

Hand Crank
Hand Lever

72-150-743-501
72-250-289-501

www.ElectricalPartManuals.com

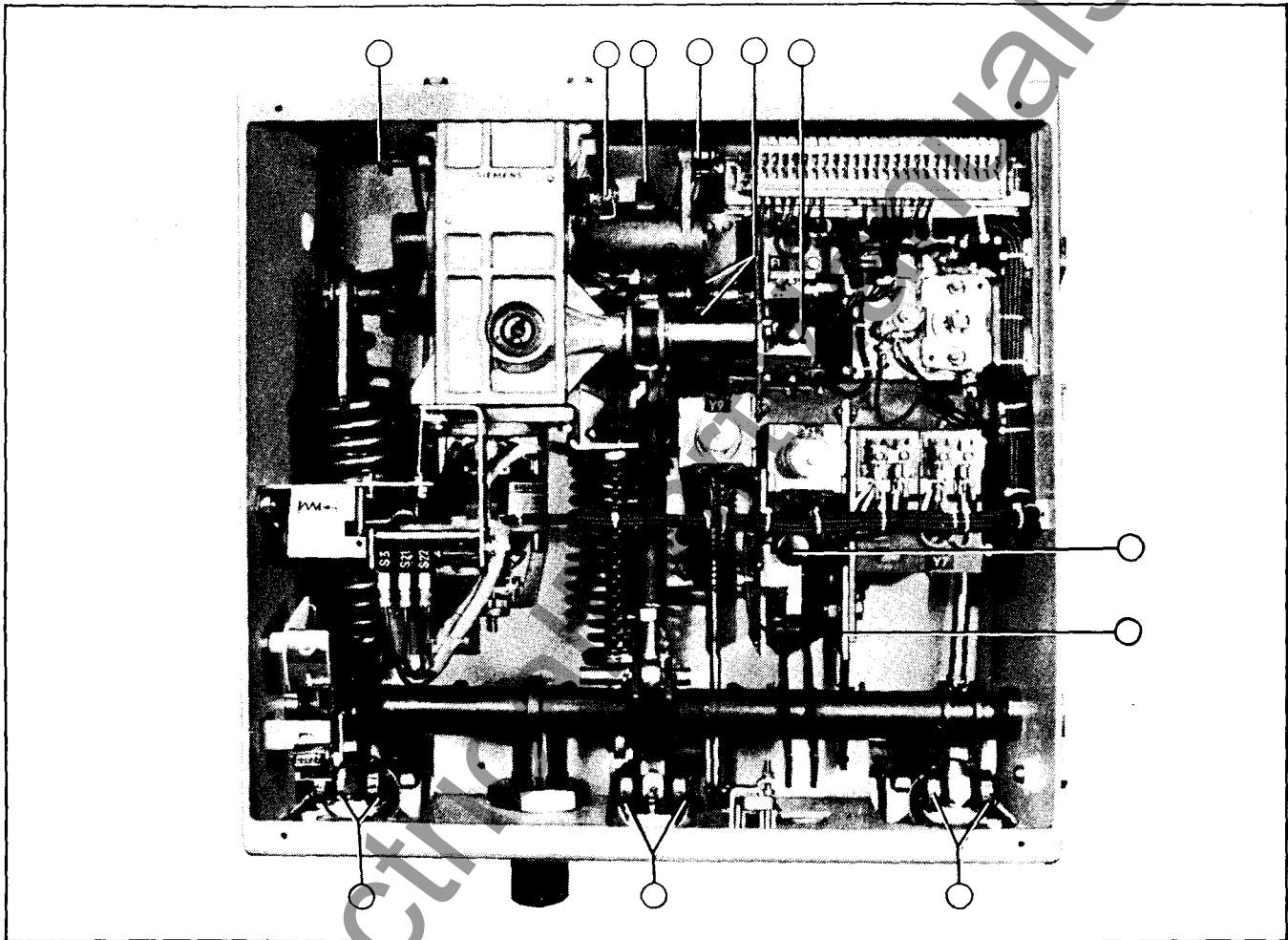

Figure 24. Points To Be Lubricated

REPLACEMENT PARTS

A list of replacement parts is sent with the breaker. A supply of these parts may be kept on hand so that the emergency repairs can be made without waiting for a shipment from the factory. Orders for replacement parts should be addressed to the nearest Siemens-Allis sales office and should include:

1. Breaker Serial number
2. Type and rating of breaker from the nameplate

3. Description of part
4. Instruction book number
5. Reference number. If none exists, a description or sketch should accompany the order.
6. Quantity required.

The breaker has a combination of inch and metric hardware. All the hardware used within the operator and interrupter mounting is metric, while all the remaining hardware used on the bushing and bus mounting and cabinet assembly, is inch. Avoid using the wrong tools when replacing any hardware.

www.ElectricalPartManuals.com

BUSHING & STAND-OFF INSULATORS

Bushings and stand-off insulators should be cleaned at regular intervals where abnormal conditions prevail. The porcelain surfaces should be checked for chips and cracks.

The bushings can be replaced by removing the hardware without affecting any other breaker part or adjustments. A typical bushing is shown in figure 25.

The oil filled bushings have a transparent oil reservoir to indicate the oil level. The oil level with respect to temperature is:

Oil Level	Oil Temperature
High	60 Degrees C (149 Degrees F)
Normal	25 Degrees C (77 Degrees F)
Low	- 40 Degrees C (- 40 Degrees F)

BUSHING CURRENT TRANSFORMER

The high voltage bushings extend through bushing transformers mounted in the cover of the high voltage compartment. Three transformers are standard on vacuum breaker, however, the BCT nameplate should be checked for the exact number, location and rating. Six are available for 12 BCT's per breaker. The bushing current transformer connections are wired to separate terminal blocks located in the control and relay compartment.



DANGER



HAZARDOUS VOLTAGE. Will cause personal injury, death or damage circuit breaker.

Current transformers must not be operated with an open circuit and must be either connected to a burden or short circuited and grounded at the terminal blocks.

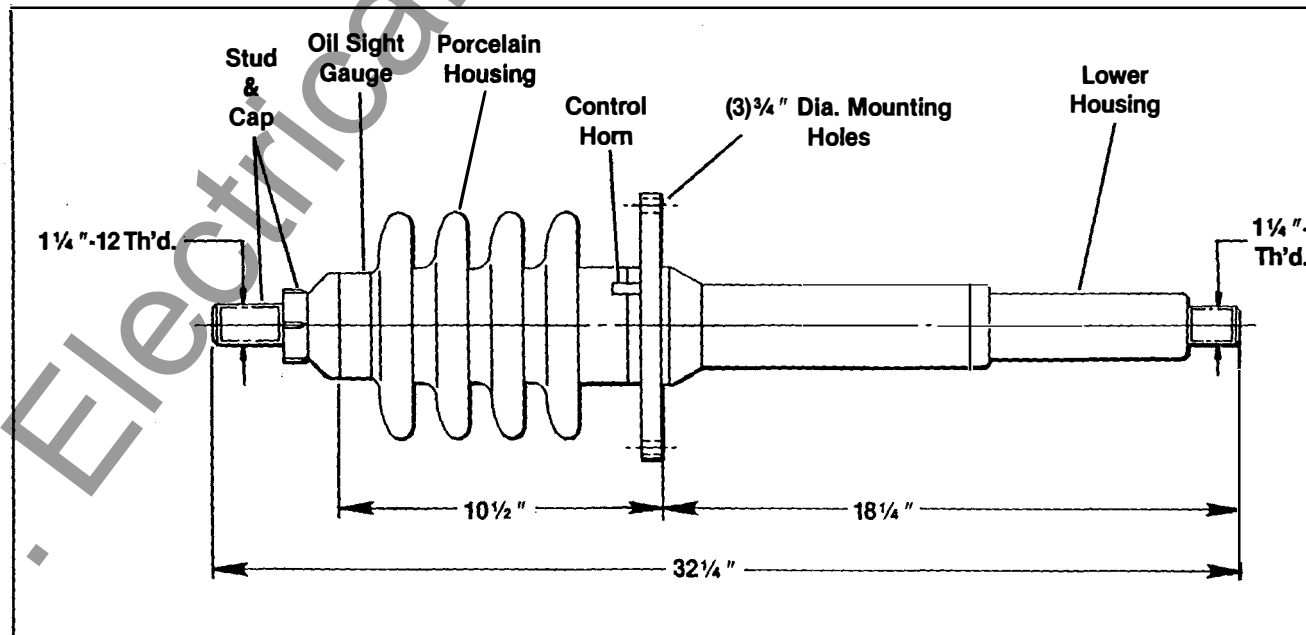

Figure 25. Typical Breaker Bushing

www.ElectricalPartManuals.com

MAINTENANCE

RELAY PANEL

The breaker can be equipped with a relay panel when required. A relay package can be supplied on a hinged panel mounted in the front of the control compartment. The following items can be accommodated on the swing out panel:

1. Breaker control switch with red and green indicating lights
2. Three overcurrent phase relays
3. One overcurrent ground relay
4. Three ammeters
5. One automatic reclosing relay

Refer to the wiring and schematic diagrams, and other instruction literature shipped with the breaker for additional specific relay requirements.

www.ElectricalPartManuals.com