

Westinghouse



Type DB Air Circuit Breakers

For Applications up to 600 Volts Ac

General Information

System Voltage

Westinghouse Type DB low voltage air circuit breakers are designed for operation on ac systems up to 600 volts and dc systems up to 250 volts. For higher voltage dc systems, the Types DR and DM breakers are available.

Normal Load Current

The normal load current that flows in a circuit should be the first consideration in selecting the proper current rating of the breaker and its trip coil for that circuit. The overload capacity of generators, motors and transformers should also be considered; standard current ratings are given on page 3.

Short-Circuit Current

The short-circuit duty imposed on a breaker by a given system is probably the most difficult factor to determine. A knowledge of the impedances of cables, buses, generators and transformers, together with any motor feedback, is necessary to calculate accurately the available short-circuit current. The presence of fault or arc impedance can appreciably reduce the calculated, available short-circuit current. However, the current limiting effects of fault or arc impedance are unpredictable and hence, should not be relied upon to reduce the interrupting duty on a breaker. Thus, the required interrupting rating of the breakers should be calculated on the basis of bolted faults.

ASA and NEMA standards are based on symmetrical interrupting ratings. The rated short-circuit current of a low voltage power circuit breaker is the maximum value of available rms symmetrical current at one-half cycle after fault inception that the circuit breaker shall be required to interrupt at the rated maximum voltage and rated frequency. Although the rated short-circuit current is expressed in symmetrical amperes, the circuit breaker shall be able to interrupt all values of asymmetrical current as well as symmetrical current produced by three-phase or single-phase circuits having short-circuit power factor of 15 percent or greater (X/R ratio 6.6 or less) at rated maximum voltage.

Most low voltage power circuit breakers are applied on systems where the X/R ratio under short-circuit conditions is safely less than 6.6. Power supply to the low voltage system through a modern liquid-filled or ventilated dry-type transformer of not more than 2500 Kva insures a safe X/R ratio. Sealed dry type transformers of not more than 2000 Kva also give safe X/R ratios. The application tables on pages 4 through 6 have been provided for quickly estimating the maximum available short-circuit current on standard low voltage transformer instal-

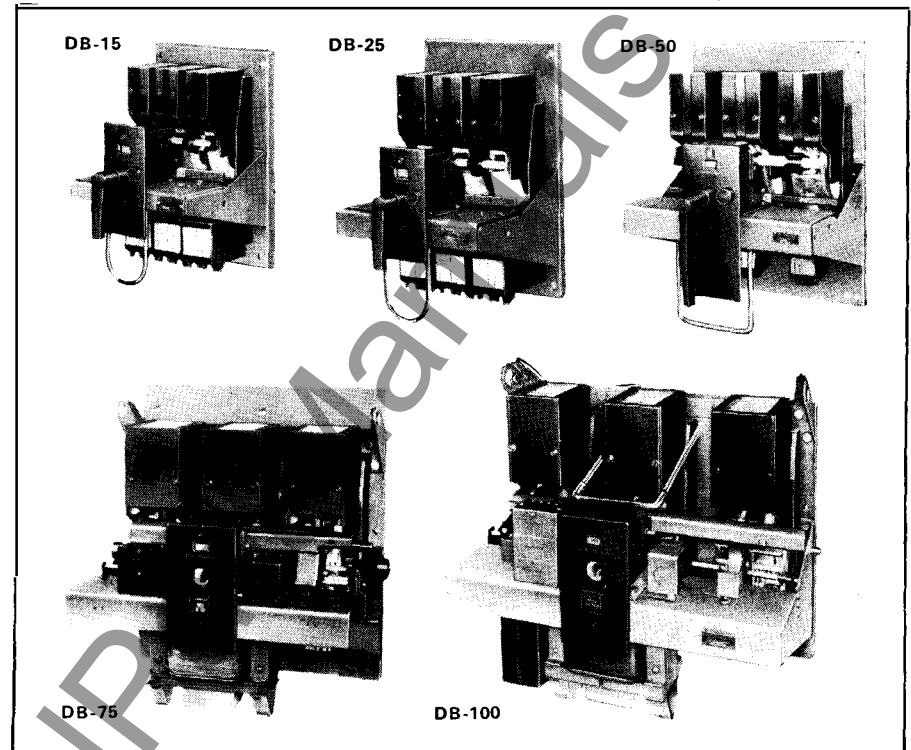

lations. The recommended DB breakers given in these tables have adequate symmetrical and asymmetrical ratings for all types of standard liquid and dry type Westinghouse transformers.

Where power is supplied to a low voltage system from generators, through current-limiting reactors, from non-standard transformers or from sealed dry-type transformers above 2000 Kva, the system X/R ratio under short-circuit conditions may exceed 6.6. In this event, breakers should not be applied on the basis of their symmetrical ratings but instead should be applied so that their asymmetrical ratings are adequate for the asymmetrical fault current available. Calculation methods and typical apparatus impedance data are given beginning on page 30.

Caution should be observed in the application of low voltage power circuit breakers with existing transformers of old designs. Many such transformers have X/R ratios greater than do modern transformers. If the X/R ratio is 6.6 or less, the application rules for modern transformers may be used; if the ratio exceeds 6.6, asymmetry factors must be considered.

The interrupting ratings, both symmetrical and asymmetrical, of standard Type DB low

voltage air circuit breakers are given on page 3

Frequency

The ratings of low voltage air circuit breakers are established for dc systems and for ac systems of 60 cycles per second. Breaker capacities and characteristics at 50 cps are essentially the same as at 60 cps and no special application considerations are required. For applications at other frequencies, refer to the nearest Westinghouse district office.

May, 1971

Supersedes AD 33-760 dated November, 1967
E. D. C/1954/DB

Westinghouse

**Application Data**

Subject	Page	Subject	Page	Subject	Page		
General Information							
System Voltage.....	1	Selective Tripping		Other Applications			
Normal Load Current.....	1	Requirements.....	11	Lighting Transformers.....	29		
Short-Circuit Current.....	1	Coordination with Fuses.....	12	Bus Duct Protection.....	29		
Frequency.....	1	Coordination with Relays.....	14	Application of Manually Operated Circuit Breakers.....	29		
Standard Ratings of Low-Voltage Air Circuit Breakers – Table A... 3							
Recommended Type DB Air Circuit Breakers for Typical Transformer Installations							
208 Volts – 3 Phase – Table B.....	4	Main Transformer Secondary Breakers.....	17	Three-Phase Fault Calculations... 30			
240 Volts – 3 Phase – Table C.....	4	Directly Connected Generation on the Low-Voltage System.....	17	System of Units and Base Quantities... 30			
480 Volts – 3 Phase – Table D.....	5	Arcing-Fault Protection.....	20	Type of Faults.....	31		
600 Volts – 3 Phase – Table E.....	6	*Cascade Arrangements					
System Operating Conditions							
Altitude.....	7	Fault Current Limits for Cascading – Table H.....	20	Time of Maximum Fault Current.....	31		
Repetitive Duty.....	7	Comparison of Selective Tripping and Cascading.....	21	Impedances.....	31		
Repetitive Duty and Normal Maintenance – Table F.....	7	Motor Circuit Protection					
Ambient Temperature.....	7	Breaker Interrupting Capacity.....	21	Approximate Transformer Impedances – Table Q.....	31		
Local Electrical Codes.....	7	Breaker Continuous Current Rating.....	21	Average Values of Machine Sub- transient Reactance – Table R.....	31		
Atmospheric and Unusual Operating Conditions.....	7	Recommended Breaker Rating – Table I.....	22	Reactance and Resistance of Copper Cables – Table S.....	31		
Ratings							
Rated Voltage.....	8	Maximum Rating or Setting of Motor Circuit Breaker – Table J.....	22	Single-Phase Reactance and Ac Resistance of Single-Phase Conductors – Table T.....	32		
Rated Continuous Current.....	8	Breaker Tripping Characteristics.....	23	Bus Duct Impedances – Table U.....	33		
Rated Interrupting Current.....	8	Breaker Selection.....	24	Bus Bar Reactances – 60 Cycles.....	33		
Rated Frequency.....	8	Motor Locked-Rotor Protection.....	24	Asymmetry Due to the D-c Component.....	34		
Rated Short-Time Current.....	8	Reduced-Voltage Starting.....	24	Sources of Short-Circuit Current.....	35		
Tripping and Closing Devices							
Series Overcurrent Tripping Devices..	8	Undervoltage Protection.....	25	General Procedure for Fault Calculations.....	36		
Tripping Characteristic Curves.....	8	Resistance Welding Applications... 25					
Reverse-Current Tripping Devices.....	9	Type DBW Breakers for Resistance Welding Machine Control – Table K... 25		Single-Phase Fault Calculations... 37			
Undervoltage Tripping Attachments..	9	Field Discharge Breakers and Resistors					
Shunt Tripping Devices.....	9	Functions and Field Discharge Resistors.....	26	Available Tripping Character- istics – Table V..... 39			
Closing Devices.....	9	Selection of Field Resistors.....	26	* Cascading is no longer a recognized arrangement. See ANSI – C 37.16 – 1970.			
Control Voltages and Operating Currents.....	10	“Maximum Probable” Ratios of In- duced Field Currents – Table L.....	26				
Other Attachments							
Control Relays.....	10	Permissible Transient Crest Voltage – Table M.....	27				
Alarm Switches.....	10	Selection of Field Discharge Breakers.....	27				
Auxiliary Switches.....	10	Ratings of Type DBF Field Discharge Breakers – Table N.....	27				
Interlocks.....	10	Simplified Application Tables.....	28				
Mountings and Enclosures							
Mountings.....	10	Recommended Field Discharge Breakers – Table O.....	28				
Enclosures.....	10	Recommended Values of Field Discharge Resistance – Table P... 28					
Individual Enclosures – Table G.....	11	Shunt Capacitor Switching... 29					

Type DB Air Circuit Breakers

For Applications up to 600 Volts Ac

Table A: Standard Ratings of Type DB Low-voltage Air Circuit Breakers

Breaker Type	Voltage		Interrupting Rating, Current Measured at Instant 1/2 Cycle After Fault, Amperes		30 Cycle Short-Time Rating Without Series Trip, Amperes		Frame Size Continuous Current Rating of Current Carrying Parts Other Than Series Overcurrent Tripping Devices Amperes
	Ac①	D-c	Asymmetrical②	Symmetrical	Asymmetrical②	Symmetrical	
DB-15	600-481	250 and Below	15000	14000	15000	14000	225
	480-241	25000	22000	15000	14000	225
	240 and Below	30000	25000	15000	14000	225
DB-25	600-481	250 and Below	25000	22000	25000	22000	600
	480-241	35000	30000	25000	22000	600
	240 and Below	50000	42000	25000	22000	600
DB-50	600-481	250 and Below	50000	42000	50000	42000	1600
	480-241	60000	50000	50000	42000	1600
	240 and Below	75000	65000	50000	42000	1600
DB-75	600-481	250 and Below	75000	65000	75000	65000	3000
	480-241	75000	65000	75000	65000	3000
	240 and Below	100000	85000	75000	65000	3000
DB-100	600-481	250 and Below	100000	85000	100000	85000	4000
	480-241	100000	85000	100000	85000	4000
	240 and Below	150000	130000	100000	85000	4000

Trip Coil Continuous Current Ratings – Amperes③

Breaker Type	Voltage		Trip Coil Continuous Current Ratings – Amperes③			
	Ac①	D-c	Range of Coil Ratings Available If Overcurrent Device Has Instantaneous Tripping for Current Above 1500% of the Coil Rating④	Range of Coil Ratings Available If Overcurrent Device Has Short-Delay Tripping for Currents Above 1500% of Coil Rating and With Short-Time Delay Not To Exceed the Values Below.⑤		
				0.1- Second (6 Cycles) Min. Band	0.233-Second (14 Cycles) Interm. Band	0.5-Second (30 Cycles) Max. Band
DB-15	600-481	250 and Below	15 to 225	100 to 225	125 to 225	150 to 225
	480-241	20 to 225	100 to 225	125 to 225	150 to 225
	240 and Below	30 to 225	100 to 225	125 to 225	150 to 225
DB-25	600-481	250 and Below	40 to 600	175 to 600	200 to 600	250 to 600
	480-241	100 to 600	175 to 600	200 to 600	250 to 600
	240 and Below	150 to 600	175 to 600	200 to 600	250 to 600
DB-50	600-481	250 and Below	200 to 1600	350 to 1600	400 to 1600	500 to 1600
	480-241	400 to 1600	350 to 1600	400 to 1600	500 to 1600
	240 and Below	600 to 1600	350 to 1600	400 to 1600	500 to 1600
DB-75	600-481	250 and Below	2000 to 3000	2000 to 3000	2000 to 3000	2000 to 3000
	480-241	2000 to 3000	2000 to 3000	2000 to 3000	2000 to 3000
	240 and Below	2000 to 3000	2000 to 3000	2000 to 3000	2000 to 3000
DB-100	600-481	250 and Below	4000	4000	4000	4000
	480-241	4000	4000	4000	4000
	240 and Below	4000	4000	4000	4000

- ① The table applies for frequencies 50 to 60 cps. For frequencies less than 50 cps, use the ratings for the 600-481 volt range.
- ② On ac systems, the asymmetrical interrupting rating is the average rms asymmetrical current. On the dc systems, it is the maximum current that any one pole of the breaker can satisfactorily interrupt.
- ③ Standard trip coil ratings are: 15-20-30-40-50-70-90-100-125-150-175-200-225-250-300-350-400-500-600-800-1000-1200-1600-2000-2500-3000-4000 ac or dc amperes.
- ④ For special individual enclosures, other than the general purpose ventilated enclosure, the maximum continuous current rating is 1200 amperes for the DB-50. This does not apply to breakers in metal-enclosed switchgear assemblies.
- ⑤ Breakers equipped with series overcurrent tripping devices having short delay can be applied only on systems where the short-time rating of the breaker is equal to or greater than the available fault current.
- ⑥ For frame sizes 3000 and 4000 (DB-75 and DB-100), range of coil ratings available if overcurrent device has instantaneous tripping or currents above 1200% of the coil rating.

www.electricalmanuals.com

Westinghouse



Recommended Type DB Air Circuit Breakers
For Application with Standard Westinghouse Transformers (Liquid, Dry Ventilated and Dry Sealed Types)

Figure 1 – Selective Trip Systems

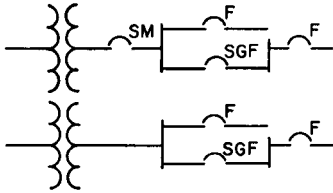

Selective

Figure 2 – Cascade Systems*

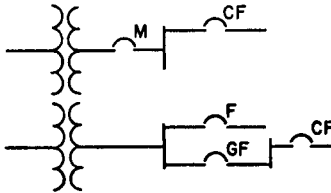

***Cascade**

Figure 3 – Fully-rated Non-selective systems

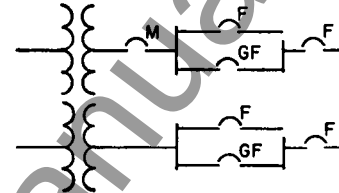

Fully-Rated

Transformer Rating 3 Phase Kva and Impedance Percent	Maximum Short Circuit Kva Available from Primary System	Rated Load Continuous Current Amperes	Short-circuit Current① Rms Symmetrical Amperes			Selective Trip Systems			Cascade Systems*			Fully-rated Non- selective Systems	
			Transformer Alone	50% Motor Load (208v) 100% Motor Load (240v)	Combined	SM Selective Main Breaker	SGF Selective Group Feeder Breaker	F Feeder Breaker	M Main Breaker	F or GF Feeder or Group Feeder Breakers	CF Cascaded Feeder Breaker	M Main Breaker	F or GF Feeder or Group Feeder Breakers

Table B: 208 Volts – 3 Phase②

300 5%	50000	834	14900	1700	16600	DB-50	DB-25	DB-15	DB-50	DB-15	DB-15	DB-50	DB-15
	100000		15700		17400		DB-25	DB-15		DB-15	DB-15		
	150000		16000		17700		DB-25	DB-15		DB-15	DB-15		
	250000		16300		18000		DB-25	DB-15		DB-15	DB-15		
	500000		16500		18200		DB-25	DB-15		DB-15	DB-15		
	Unlimited		16700		18400		DB-25	DB-15		DB-15	DB-15		
500 5%	50000	1388	23100	2800	25900	DB-50	DB-50	DB-25	DB-50	DB-25	DB-15	DB-50	DB-25
	100000		25200		28000		DB-50	DB-25		DB-15	DB-25		
	150000		26000		28800		DB-50	DB-25		DB-15	DB-25		
	250000		26700		29500		DB-50	DB-25		DB-15	DB-25		
	500000		27200		30000		DB-50	DB-25		DB-15	DB-25		
	Unlimited		27800		30600		DB-50	DB-25		DB-15	DB-25		
760 5.75%	50000	2080	28700	4200	32900	DB-75	DB-50	DB-25	DB-75	DB-25	DB-15	DB-75	DB-25
	100000		32000		36200		DB-50	DB-25		DB-15	DB-25		
	150000		33300		37500		DB-50	DB-25		DB-15	DB-25		
	250000		34400		38600		DB-50	DB-25		DB-15	DB-25		
	500000		35200		39400		DB-50	DB-25		DB-15	DB-25		
	Unlimited		36200		40400		DB-50	DB-25		DB-15	DB-25		
1000 5.75%	50000	2780	35900	5600	41500	DB-75	DB-50	DB-25	DB-75	DB-25	DB-15	DB-75	DB-25
	100000		41200		46800		DB-75	DB-50		DB-15	DB-50		
	150000		43300		48900		DB-75	DB-50		DB-15	DB-50		
	250000		45200		50800		DB-75	DB-50		DB-25	DB-50		
	500000		46700		52300		DB-75	DB-50		DB-25	DB-50		
	Unlimited		48300		53900		DB-75	DB-50		DB-25	DB-50		

Table C: 240 Volts – 3 Phase②

300 5%	50000	722	12900	2900	15800	DB-50	DB-25	DB-15	DB-50	DB-15	DB-15	DB-50	DB-15
	100000		13600		16500		DB-25	DB-15		DB-15	DB-15		
	150000		13900		16800		DB-25	DB-15		DB-15	DB-15		
	250000		14100		17000		DB-25	DB-15		DB-15	DB-15		
	500000		14300		17200		DB-25	DB-15		DB-15	DB-15		
	Unlimited		14400		17300		DB-25	DB-15		DB-15	DB-15		
600 5%	50000	1203	20000	4800	24800	DB-50	DB-50	DB-15	DB-50	DB-15	DB-15	DB-50	DB-15
	100000		21900		26700		DB-50	DB-25		DB-15	DB-25		
	150000		22500		27300		DB-50	DB-25		DB-15	DB-25		
	250000		23100		27900		DB-50	DB-25		DB-15	DB-25		
	500000		23600		28400		DB-50	DB-25		DB-15	DB-25		
	Unlimited		24100		28900		DB-50	DB-25		DB-15	DB-25		
750 5.75%	50000	1804	24900	7200	32100	DB-75	DB-50	DB-25	DB-75	DB-25	DB-15	DB-75	DB-25
	100000		27800		35000		DB-50	DB-25		DB-15	DB-25		
	150000		28900		36100		DB-50	DB-25		DB-15	DB-25		
	250000		29800		37000		DB-50	DB-25		DB-15	DB-25		
	500000		30600		37800		DB-50	DB-25		DB-15	DB-25		
	Unlimited		31400		38600		DB-50	DB-25		DB-15	DB-25		

* Cascading is no longer a recognized arrangement.
See ANSI – C 37.16 – 1970.

Type DB Air Circuit Breakers

For Applications up to 600 Volts Ac

Recommended Type DB Air Circuit Breakers For Application with Standard Westinghouse Transformers (Liquid, Dry Ventilated and Dry Sealed Type)

Transformer Rating 3 Phase Kva and Impedance Percent	Maximum Short Circuit Kva Available from Primary System	Rated Load Continuous Current Amperes	Short-circuit Current ^① Rms Symmetrical Amperes			Selective Trip Systems			Cascade Systems*			Fully-rated Non-Selective Systems				
			Transformer Alone	100% Motor Load	Combined	SM Selective Main Breaker	SGF Selective Group Feeder Breaker	F Feeder Breaker	M Main Breaker	F or GF Feeder or Group Breakers	CF Cascaded Feeder Breaker	M Main Breaker	F or GF Feeder or Group Breakers			
Table C: 240 Volts – 3 Phase^② (Continued)																
1000	50000	2406	31000	9600	40600	DB-75	DB-50	DB-25	DB-75	DB-25	DB-15	DB-75	DB-25			
	5.75%		100000				35600			45200				DB-75	DB-50	DB-15
			150000				37500			47100				DB-75	DB-50	DB-15
			250000				39100			48700				DB-75	DB-50	DB-15
			500000				40400			50000				DB-75	DB-50	DB-15
	Unlimited	41800	51400	DB-75	DB-50	DB-25	DB-50									
1500	50000	3609	41200	14400	55600	DB-100	DB-75	DB-50	DB-100	DB-50	DB-25	DB-100	DB-50			
	5.75%		100000				49800			64200				DB-75	DB-50	DB-50
			150000				53500			67900				DB-100	DB-75	DB-25
			250000				56800			71200				DB-100	DB-75	DB-25
			500000				59600			74000				DB-100	DB-75	DB-25
	Unlimited	62800	77200	DB-100	DB-75	DB-25	DB-75									
Table D: 480 Volts – 3 Phase^②																
300	50000	361	6400	1400	7800	DB-25	DB-15	DB-15	DB-25	DB-15	DB-15	DB-25	DB-15			
	5%		100000				6800			8200				DB-15	DB-15	DB-15
			150000				6900			8300				DB-15	DB-15	DB-15
			250000				7000			8400				DB-15	DB-15	DB-15
			500000				7100			8500				DB-15	DB-15	DB-15
	Unlimited	7200	8600	DB-15	DB-15	DB-15	DB-15									
500	50000	601	10000	2400	12400	DB-50	DB-15	DB-15	DB-50	DB-15	DB-15	DB-50	DB-15			
	5%		100000				10900			13300				DB-15	DB-15	DB-15
			150000				11300			13700				DB-15	DB-15	DB-15
			250000				11600			14000				DB-15	DB-15	DB-15
			500000				11800			14200				DB-25	DB-15	DB-15
	Unlimited	12000	14400	DB-25	DB-15	DB-15	DB-15									
750	50000	902	12400	3600	16000	DB-50	DB-25	DB-15	DB-50	DB-15	DB-15	DB-50	DB-15			
	5.75%		100000				13900			17500				DB-25	DB-15	DB-15
			150000				14400			18000				DB-25	DB-15	DB-15
			250000				14900			18500				DB-25	DB-15	DB-15
			500000				15300			18900				DB-25	DB-15	DB-15
	Unlimited	15700	19300	DB-25	DB-15	DB-15	DB-15									
1000	50000	1203	15500	4800	20300	DB-50	DB-25	DB-15	DB-50	DB-15	DB-15	DB-50	DB-15			
	5.75%		100000				17800			22600				DB-50	DB-25	DB-15
			150000				18700			23500				DB-50	DB-25	DB-15
			250000				19600			24400				DB-50	DB-25	DB-15
			500000				20200			25000				DB-50	DB-25	DB-15
	Unlimited	20900	25700	DB-50	DB-25	DB-15	DB-25									
1500	50000	1804	20600	7200	27800	DB-75	DB-50	DB-25	DB-75	DB-25	DB-15	DB-75	DB-25			
	5.75%		100000				24900			32100				DB-50	DB-50	DB-15
			150000				26700			33900				DB-50	DB-50	DB-15
			250000				28400			35600				DB-50	DB-50	DB-15
			500000				29800			37000				DB-50	DB-50	DB-15
	Unlimited	31400	38600	DB-50	DB-50	DB-15	DB-50									
2000	50000	2406	24700	9600	34300	DB-75	DB-50	DB-50	DB-75	DB-50	DB-15	DB-75	DB-50			
	5.75%		100000				31000			40600				DB-50	DB-50	DB-15
			150000				34000			43600				DB-75	DB-50	DB-25
			250000				36700			46300				DB-75	DB-50	DB-25
			500000				39100			48700				DB-75	DB-50	DB-25
	Unlimited	41800	51400	DB-75	DB-75	DB-25	DB-75									
2500	50000	3008	28000	12000	40000	DB-100	DB-50	DB-50	DB-100	DB-50	DB-15	DB-100	DB-50			
	5.75%		100000				36500			48500				DB-75	DB-50	DB-25
			150000				40500			52500				DB-75	DB-75	DB-25
			250000				44600			56600				DB-75	DB-75	DB-25
			500000				48100			60100				DB-75	DB-75	DB-50
	Unlimited	52300	64300	DB-75	DB-75	DB-50	DB-75									

M=Main breaker selected to have adequate interrupting and continuous current ratings.
 SM=Selective main breaker selected to have adequate interrupting, short-time and continuous current ratings and equipped with selective series overcurrent tripping devices.
 GF=Group feeder breaker selected to have adequate interrupting rating. The breaker is assumed to have adequate continuous current capacity.
 SGF=Selective group feeder breaker selected to have adequate interrupting and short-time ratings, and equipped with selective series overcurrent tripping devices. The breaker is assumed to have adequate continuous current capacity.
 F=Feeder breaker selected to have adequate interrupting rating.
 CF=Cascaded feeder breaker, where the available fault current exceeds the breaker interrupting rating, selected to comply with cascade rules in page 21.
 ①=Short circuit currents are calculated by dividing transformer full-load current by the sum of transformer and system impedance expressed in per unit. Motor contribution is assumed to be 4 times total motor load. For details see page 32.
 ②=Standard ranges of trip coil ratings are listed in a table on page 3.
 *Cascading is no longer a recognized arrangement. See ANSI – C 37.16 – 1970.

Westinghouse



Recommended Type DB Air Circuit Breakers
For Application with Standard Westinghouse Transformers (Liquid, Dry Ventilated and Dry Sealed Type)

Figure 1 – Selective Trip Systems

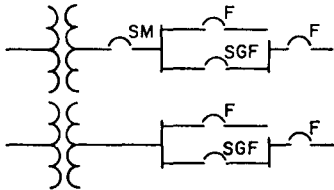

Figure 2 – Cascade Systems*

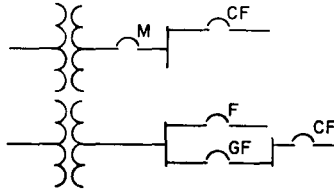
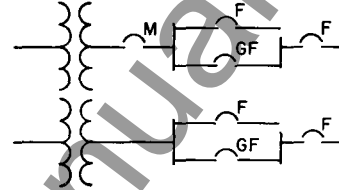

Figure 3 – Fully-rated Non-selective Systems



Transformer Rating 3 Phase Kva and Impedance Percent	Maximum Short Circuit Kva Available from Primary System	Rated Load Continuous Current Amperes	Short-circuit Current ^① Rms Symmetrical Amperes			Selective Trip Systems			Cascade Systems*			Fully-rated Non-selective Systems	
			Transformer Alone	100% Motor Load	Combined	SM Selective Main Breaker	SGF Selective Group Feeder Breaker	F Feeder Breaker	M Main Breaker	F or GF Feeder or Group Feeder Breakers	CF Cascaded Feeder Breaker	M Main Breaker	F or GF Feeder or Group Feeder Breakers

Table E: 600 Volts – 3 Phase^②

300	50000	289	5200	1200	6300	DB-25	DB-15	DB-15	DB-25	DB-15	DB-15	DB-25	DB-15						
	100000		5500											6700	DB-15	DB-15	DB-15	DB-15	DB-15
	150000		5600											6800	DB-15	DB-15	DB-15	DB-15	DB-15
	250000		5600											6800	DB-15	DB-15	DB-15	DB-15	DB-15
	500000		5700											6900	DB-15	DB-15	DB-15	DB-15	DB-15
	Unlimited		5800		7000		DB-15	DB-15		DB-15	DB-15		DB-15						
500	50000	481	8000	1900	9900	DB-25	DB-15	DB-15	DB-25	DB-15	DB-15	DB-25	DB-15						
	100000		8700											10600	DB-15	DB-15	DB-15	DB-15	DB-15
	150000		9000											10900	DB-15	DB-15	DB-15	DB-15	DB-15
	250000		9300											11200	DB-15	DB-15	DB-15	DB-15	DB-15
	500000		9400											11300	DB-15	DB-15	DB-15	DB-15	DB-15
	Unlimited		9600		11500		DB-15	DB-15		DB-15	DB-15		DB-15						
750	50000	722	10000	2900	12900	DB-50	DB-15	DB-15	DB-50	DB-15	DB-15	DB-50	DB-15						
	100000		11100											14000	DB-15	DB-15	DB-15	DB-15	DB-15
	150000		11600											14500	DB-25	DB-25	DB-25	DB-25	DB-15
	250000		11900											14800	DB-25	DB-25	DB-25	DB-25	DB-15
	500000		12200											15100	DB-25	DB-25	DB-25	DB-25	DB-15
	Unlimited		12600		15500		DB-25	DB-25		DB-15	DB-15		DB-25						
1000	50000	962	12400	3900	16300	DB-50	DB-25	DB-25	DB-50	DB-25	DB-15	DB-50	DB-25						
	100000		14300											18200	DB-25	DB-25	DB-25	DB-25	DB-15
	150000		15000											18900	DB-25	DB-25	DB-25	DB-25	DB-15
	250000		15600											19500	DB-25	DB-25	DB-25	DB-25	DB-15
	500000		16200											20100	DB-25	DB-25	DB-25	DB-25	DB-15
	Unlimited		16700		20600		DB-25	DB-25		DB-15	DB-15		DB-25						
1500	50000	1444	16500	5800	22300	DB-50	DB-50	DB-50	DB-50	DB-50	DB-15	DB-50	DB-50						
	100000		20000											25800	DB-50	DB-50	DB-50	DB-25	DB-50
	150000		21400											27200	DB-50	DB-50	DB-50	DB-25	DB-50
	250000		22700											28500	DB-50	DB-50	DB-50	DB-25	DB-50
	500000		23900											29700	DB-50	DB-50	DB-50	DB-25	DB-50
	Unlimited		25100		30900		DB-50	DB-50		DB-25	DB-25		DB-50						
2000	50000	1924	19700	7800	27500	DB-75	DB-50	DB-50	DB-75	DB-50	DB-25	DB-75	DB-50						
	100000		24800											32600	DB-50	DB-50	DB-50	DB-25	DB-50
	150000		27200											35000	DB-50	DB-50	DB-50	DB-25	DB-50
	250000		29400											37200	DB-50	DB-50	DB-50	DB-25	DB-50
	500000		31300											39100	DB-50	DB-50	DB-50	DB-25	DB-50
	Unlimited		33500		41300		DB-50	DB-50		DB-25	DB-25		DB-50						
2500	50000	2405	22400	9600	32000	DB-75	DB-50	DB-50	DB-75	DB-50	DB-25	DB-75	DB-50						
	100000		29200											38800	DB-50	DB-50	DB-50	DB-25	DB-50
	150000		32400											42000	DB-50	DB-50	DB-50	DB-25	DB-50
	250000		35600											45200	DB-75	DB-75	DB-75	DB-50	DB-75
	500000		38500											48100	DB-75	DB-75	DB-75	DB-50	DB-75
	Unlimited		41800		51400		DB-75	DB-75		DB-50	DB-50		DB-75						

M = Main breaker selected to have adequate interrupting and continuous current ratings.
 SM = Selective main breaker selected to have adequate interrupting, short-time and continuous current ratings and equipped with selective series overcurrent tripping devices.
 GF = Group feeder breaker selected to have adequate interrupting rating. The breaker is assumed to have adequate continuous current capacity.
 SGF = Selective group feeder breaker selected to have adequate interrupting and short-time ratings, and equipped with selective series overcurrent tripping devices. The breaker is assumed to have adequate continuous current capacity.
 F = Feeder breaker selected to have adequate interrupting rating.
 CF = Cascaded feeder breaker, where the available fault current exceeds the breaker interrupting rating, selected to comply with cascade rules on page 20.
 ① = Short-circuit currents are calculated by dividing transformer full-load current by the sum of transformer and system impedances expressed in per unit. Motor contribution is assumed to be 4 times total motor load. For details see page 30.
 ② = Standard ranges of trip coil ratings are listed in a table on page 3.
 * Cascading is no longer a recognized arrangement. See ANSI – C 37.16 – 1970.

Type DB Air Circuit Breakers

For Applications up to 600 Volts Ac

System Operating Conditions

Altitude

When the breakers are to be installed at altitudes higher than 3300 feet, the voltage and current ratings are subject to correction factors specified by the AIEE and NEMA standards.

These are as follows:

Altitude	Correcting Factor	
	Voltage	Current
3300 ft. (1000 meters)	1.00	1.000
4000 ft. (1200 meters)	0.98	0.996
5000 ft. (1500 meters)	0.95	0.990
10000 ft. (3000 meters)	0.80	0.960

Multiplying the standard rating of the breakers by the above factors gives the rating at the altitude indicated.

Repetitive Duty

Power operated circuit breakers, when operating under usual service conditions, shall be capable of operating the number of times specified in table F, below. The operating conditions and the permissible effect of such operations upon the breaker are given in the notes following the table.

This table applies to all parts of a circuit breaker that function during normal operation. It does not apply to other parts, such as overcurrent tripping devices, that function only during infrequent, abnormal circuit conditions.

Some typical applications that usually require an analysis of the repetitive duty are:

- plugging
- jogging
- frequent motor starting
- arc furnaces
- annealing furnaces
- reversing mill motor applications

Applications like plugging, jogging and reverse mill motor applications usually require contactors for the repetitive switching operations; however, it should be remembered that standard contactors frequently require a circuit breaker somewhere in the circuit that is capable of giving short-circuit protection.

Notes for Table F Below

Servicing

1. Servicing shall consist of adjusting, cleaning, lubricating, tightening, etc., as recommended by the manufacturers. The operations listed are on the basis of servicing at intervals of six months or less.

Circuit Conditions

2. When closing and opening no load.
3. When closing and opening currents up to the continuous current rating of the circuit breaker at voltages up to the maximum design voltage and at 80 percent power factor or higher.
4. When closing currents up to 600 percent and opening currents up to 100 percent (80 percent power factor or higher) of the continuous current rating (frame size) of the circuit breaker at voltages up to the maximum design voltage.

Operating Conditions

5. With rated control voltage.
6. Frequency of operation not to exceed 20 in 10 minutes or 30 in one hour. Rectifiers or other auxiliary devices may further limit the frequency of operations.
7. Servicing at no greater intervals than shown in column 2 of table F.

Conditions of the Circuit Breaker After the Operations Shown in the Table

8. No parts shall have been replaced except as qualified by note 11.
9. The circuit breaker shall be in a condition to meet all of its continuous current, and voltage ratings and one opening test at rated short circuit current.
10. The circuit breaker shall be in a condition to meet all its continuous current and voltage ratings but not necessarily its interrupting rating.

Operation Under Fault Conditions

11. If a fault operation occurs before the completion of the permissible operations, it is not to be inferred that the breaker can afterward meet its interrupting rating or complete its number of operations without servicing and making replacements if necessary.

Ambient Temperature

Westinghouse Type DB low voltage air circuit breakers are suitable for operation at their standard ratings when and where the ambient temperature does not exceed 40 degrees C. When the breakers are mounted in individual enclosures (of the ventilated type) or in metal enclosed switchgear assemblies, the standard ratings are applicable provided the ambient temperature outside of the enclosure does not exceed 40 degrees C.

Local Electrical Codes

Type DB low voltage air circuit breakers are built to conform to the standards of the National Electrical Manufacturers Association, publication SG-3. The breakers and their characteristics are designed so that they are applicable where National Electrical Code requirements apply. Breakers requiring special characteristics in order to meet certain city, state or other electrical codes must be referred to the nearest Westinghouse district office

Atmospheric and Unusual Operating Conditions

When other than what would be considered normal operating conditions exist, special precautions should be taken to determine if standard apparatus will be satisfactory. The following are among the conditions for which special attention should be given in applying breakers:

1. Exposure to damaging or explosive fumes, dust, vapors, etc.
2. Exposure to excessive or abrasive dust.
3. Exposure to salt spray, excessive moisture, etc.
4. Exposure to excessively high or low temperatures.
5. Subjection to abnormal vibration, shocks or tilting.
6. Unusual operating duty such as frequency of operation and installations inaccessible for maintenance.

For some of the above abnormal operating conditions, various types of individual enclosures may be required for safety reasons to maintain proper breaker performance. Refer to table G, page 11, for a list of available enclosures and the conditions for which they are recommended.

Table F: Repetitive Duty and Normal Maintenance[Ⓢ] (See notes above)

Breaker Type	Number of Operations Between Servicing	Number of Operations				
		No Load Mechanical	Full Load Non-Fault	Full Load Fault	Inrush Non-Fault	Inrush Fault
		Note 1	Notes 2, 5, 6, 7, 8 and 9	Notes 3, 5, 6, 7, 8 and 10	Notes 3, 5, 6, 7, 8, 9 and 11	Notes 4, 5, 6, 7, 8, and 10
DB-15	2500	25000	5000	4000	3500	2500
DB-25	1750	25000	3500	2800	2500	1750
DB-50	500	8000	1000	800	750	500
DB-75	250	3000	500	400
DB-100	250	3000	500	400

Ⓢ ASA C37.13-9.9 for notes and C37.16 for tabulation.

Westinghouse



Ratings

Rated Voltage

All DB breakers are designed for 600 volts ac and meet the insulation requirements of that voltage class. When applied at other voltages, they have interrupting ratings per table A. The maximum voltages at which these interrupting ratings apply are listed below:

Ac Rms		Dc	
Voltage Ratings	Maximum Voltage	Voltage Ratings	Maximum Voltage
240	250	250	300
480	500	275Ⓣ	325Ⓣ
600	630

Ⓣ For mining applications.

Rated Continuous Current

Circuit breakers are rated upon a maximum basis. They are circuit interrupters and protective devices, and as such, may be called upon at all time to successfully remove from service other equipment or circuits. Furthermore, after such a circuit interruption, their current carrying ability may be reduced. Because of these conditions which differ from those for generators, motors, transformers, etc., it is not practical to establish overload ratings.

The trip coils used with series overcurrent tripping devices are also rated on a maximum basis; that is, although the device can be set to pick-up at currents in excess of 100 percent of the trip coil rating, the trip coil itself cannot carry continuously a current in excess of its rating without exceeding the allowable temperature rise. It should be remembered however, that breakers properly applied will have trip coil ratings in excess of the normal continuous load current of the apparatus or circuit that the breaker is protecting.

Extended overload settings are provided (up to 160 percent) and may be required in some applications so that the breaker can be set to maintain continuity of service during load surges that are of such duration and magnitude that will not be harmful to the circuit or apparatus that the breaker is protecting.

Rated Interrupting Current

The interrupting rating of a breaker is expressed as the maximum current that the breaker can interrupt at a specified voltage.

1. In ac circuits, the current is defined in symmetrical rms amperes. The current is measured at the instant $\frac{1}{2}$ cycle after the fault occurs.

In a 3-phase circuit, the asymmetrical current (total short-circuit current including

asymmetry due to the ac component) is defined as the average of the rms values of asymmetrical currents in the three phases.

2. In dc circuits, it is the maximum value of the current flowing during the fault transient.

The standard interrupting duty cycle of a circuit breaker with instantaneous tripping for fault currents shall consist of an opening operation, followed after a 15-second interval by a close-open operation.

The standard interrupting duty cycle of a circuit breaker with delayed tripping for fault currents shall consist of an opening operation, followed after a 15-second interval by a close-open operation, the tripping being delayed by the associated tripping devices.

At the end of any performance at or within its interrupting rating, the circuit breaker shall be in the following condition:

1. Mechanical: The circuit breaker shall be in substantially the same mechanical condition as at the beginning.
2. Electrical: The circuit breaker shall be capable of withstanding rated voltage in the open position and of carrying rated current at rated voltage for a limited time but not necessarily without exceeding the rated temperature rise.

Applications requiring more than the standard duty cycle, or involving automatic reclosing, should be referred to East Pittsburgh Office.

Rated Frequency

This is the frequency (or range of frequencies) for which the other ratings are applicable. The breaker ratings listed are applicable on 25-60 cycle ac systems.

Rated Short-Time Current

This is the value of fault current that the breaker can successfully carry for a short-time interval, based on the following duty cycle:

The standard short-time duty cycle shall consist of maintaining rated short-time current for two periods of one-half second each, with a 15-second interval of zero current between the one-half second periods

The short-time current is defined in the same manner as the interrupting current.

Breakers equipped with selective overcurrent devices, which give time delay tripping for fault currents, must not be applied on systems where the available fault current can exceed the short-time rating.

At the end of any performance at or within its short-time rating, the circuit breaker shall

be capable of carrying rated continuous current without exceeding its rated temperature rise and shall be capable of meeting its interrupting rating.

When low voltage breakers are applied without series trips, then the time delay furnished by the relays must be checked to ensure that the short-time current rating of the breaker is not exceeded.

Tripping and Closing Devices

Series Overcurrent Tripping Devices

There are three basic overcurrent tripping characteristics used on type DB low voltage breakers:

1. Long-delay: This characteristic is furnished by a magnetic element which gives a delayed tripping in the order of seconds and minutes for values of overcurrent only a few multiples of the trip coil rating. The time delay is obtained by means of adjustable valves that control the rate at which air enters an expanding air chamber. Its usual function is to furnish overload protection for conductors and apparatus.

Two settings are required to completely define the long-delay characteristic, namely, a pick-up setting and a time-delay setting.

2. Short-delay: This characteristic is also furnished by a magnetic element that gives a time delay in the order of cycles for heavy currents of fault-current magnitude. The time delay is obtained by means similar to the long delay except that the valve orifice is larger allowing a greater rate of air to flow and, hence, giving only a short-time delay. Its usual function is to provide a short-time delay for fault currents to give selectivity with other circuit breakers.

Two settings are required to completely define the short-delay characteristic, namely, a pick-up setting and a time-delay setting

3. Instantaneous Trips: This characteristic is furnished by a magnetic instantaneous device with no intentional time delay. Its usual function is to give short-circuit protection to load circuits. It is also used on breakers in cascade arrangements. Only pick-up setting is required to define the instantaneous characteristic.

Tripping Characteristic Curves

Long-delay characteristics are usually furnished in conjunction with either short-delay or instantaneous trip characteristics in the same overcurrent device. The combined tripping characteristics are shown by reference curves. These curves also show the various coil ratings and ranges of adjustment of the available devices and the

Type DB Air Circuit Breakers

For Applications up to 600 Volts Ac

pick-up tolerances of the individual characteristics. For available curves, see table V.

Special instantaneous trips only or short-delay characteristics only are also available. For these special characteristics, refer to the nearest Westinghouse district office.

Reverse-Current Tripping Devices

Reverse-current tripping devices of the instantaneous type are available for the type DB breakers for applications on dc systems. The device will trip for reverse-current down to 5 percent of the current rating. The range of adjustment is 5 to 25 percent with calibrations at 5 and 25 percent.

To reset the armature of the device after tripping, an "a" contact of the breaker auxiliary switch is required to open the potential coil circuit

In the standard arrangement for reverse-current tripping devices on type DB breakers, the device occupies one of the pole spaces on a standard 3-pole frame. This means that a standard type DB breaker, with a reverse-current tripping device, is limited to a two-pole breaker with reverse-current tripping on one pole. Series overcurrent tripping devices can also be supplied on each pole. See Figure 1. Other special arrangements have been supplied in the past; for special requirements, refer to the nearest Westinghouse district office.

Figure 1: Standard type DB breaker with one reverse-current (RC) and two series overcurrent (OC) tripping device

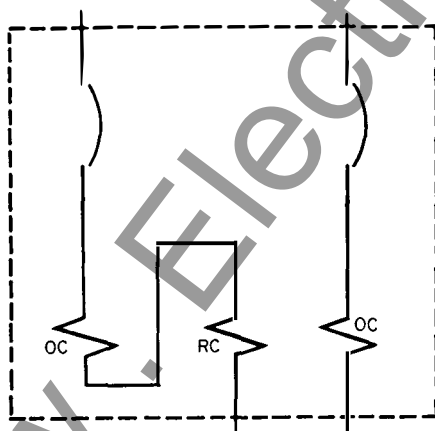

Undervoltage Tripping Attachments

An undervoltage tripping attachment acts to trip the circuit breaker when the voltage on its solenoid operating coil is insufficient to retain a spring loaded core. The dropout point falls within a band of 30 to 60 per-

cent of nominal coil voltage and is not adjustable.

Undervoltage attachments are available either as instantaneous type or time delay type. The time delay type has an extreme range of adjustment from 1 to 10 seconds and its normal setting will give a delay of 4 to 7 seconds.

The undervoltage device is automatically reset when the breaker opens. The delay time of the time delay device is shorter than normal for approximately one minute after resetting, so that if there are two undervoltage operations in quick succession there may be less time delay on the second than on the first.

Shunt Tripping Devices

Shunt trip attachments are solenoid mechanisms that trip the breaker when energized through a control switch contact or relay contacts. Shunt trip attachments are required on all electrically operated breakers and on breakers that are tripped by relays.

The shunt trips are designed for intermittent duty only and hence, the trip circuit must be opened by an auxiliary switch contact.

Closing Devices

There are three types of closing mechanisms available with the DB power circuit breaker: dependent manual, electric solenoid and independent manual (spring closing). There are certain limitations to the application of the manual closing mechanism. For details see page 29.

The spring closing mechanism is available on the DB-15, DB-25, and DB-50 breakers. Breakers equipped with the spring closing mechanism can be used with instantaneous or selective delayed trips up to the full short-time rating of the breaker. The spring closing mechanism assures rapid and safe closing of the breaker, independent of an operator's strength or effort on the closing handle, against all possible fault currents, which are within the short-time rating of the breaker.

Westinghouse



Control Voltages and Operating Currents

Electrically operated air circuit breakers should be operated from reliable sources of control power. Standard control voltages

and ranges for electrically operated low voltage breakers are measured at the mechanism terminals for solenoid mechanisms given below:

any combination of make and break contacts desired.

The auxiliary switch contacts have the following characteristics:

Contacts can carry 15 amperes continuously or 250 amperes for 3 seconds.

Control Voltages

Direct Current

Standard Control Voltages	To Close	To Trip
24 48	14 to 30① 28 to 60
125 250	90 to 130 180 to 260	70 to 140 140 to 280

Alternating Current

Standard Control Voltages	To Close	To Trip
115 230	95 to 125 190 to 250	95 to 125 190 to 250
460	380 to 500	380 to 500

Interrupting Capacity:

Volts	Circuit	
	Non-Inductive	Inductive
125 Dc 250 Dc	11 Amperes 2 Amperes	6.25 Amperes 1.75 Amperes
115 Ac 450 Ac	75 Amperes 25 Amperes	15 Amperes 5 Amperes

① 24-volt tripping is not recommended

Operating Currents

Type of Breaker	No. of Poles	Closing Current – Volts				Tripping Current – Volts					
		125 Dc	250 Dc	230 Ac	460 Ac	48 Dc	125 Dc	250 Dc	115 Ac	230 Ac	460 Ac
DB-15	2, 3	20	10	30	15	5	2	1	1	.5	.2
DB-25	2, 3	23	10	35	20	5	2	1	1	.5	.2
DB-50	2, 3	20	10	20	10	5	2	1	1	.5	.2
DB-75	2, 3	32	18	32	18	5	2	1	1	.5	.2
DB-100	2, 3	32	18	32	18	5	2	1	1	.5	.2

Control power for ac closing of low voltage breakers in metal-enclosed switchgear is usually taken from the bus or line-side of the breaker through current limiting fuses, or through standard fuses and current limiting resistors. When it is necessary to supply closing power through a control

power transformer, a 3 Kva transformer is used for all breaker types and regardless of the number of breakers. For tripping power only, a 250 va control power transformer is adequate for all breaker ratings and regardless of the number of breakers.

Interlocks

Interlocks can also be supplied to prevent the operation of breakers under certain conditions. For example, two breakers may be interlocked so that only one may be closed at any one time but both may be open at any one time. Electric lockout attachments or key interlocks are recommended to perform these special functions. Key interlocks on drawout switchgear are so designed and mounted that the interlocking function will not be defeated by substitution of a different breaker in the cell. Mechanical interlocks are also available for non-drawout breakers.

Electric lockout attachments are available on the type DB breakers. The lockout prevents closing of the breaker by holding the breaker linkage in the trip-free position. Energizing the lockout coil frees the linkage and permits closing the breaker. After the breaker is closed, de-energizing the lockout coil does not cause tripping. Standard coil voltages are 48, 125 or 250 dc and 115 230 or 460 ac.

Other Attachments

Control Relays

A control relay is normally supplied on each electrically operated type DB breaker. The function of the control relay is to close and open the closing solenoid circuit of the breaker during a closing operation, so that the heavy closing current does not pass through the control switch or other initiating device.

When the control switch of the breaker is closed, it energizes the control relay. A contact from the relay completes the closing solenoid circuit. When the breaker is closed, the breaker closing mechanism mechanically opens the relay contact which interrupts the closing current.

Alarm Switches

It may be desirable when a breaker trips on a fault or overload to ring an alarm of some type. Alarm switches are available on the type DB breaker that will close their contact when the breaker is tripped by the series overcurrent device but which is mechanically blocked from closing when the break-

er is manually tripped or opened by the shunt trip device. Undervoltage tripping attachment, when supplied, can also operate an alarm.

Auxiliary Switches

Auxiliary switch circuits are available on the type DB breakers in groups of 4 or 8②. These switches are used to control indicating lamps, shunt trip coil circuits or other duties in automatic or manual control schemes.

The switches are contained in molded cases. A rotary design moving contact is used with a wiping action between contact surfaces. The contact faces are silverplated and are held against each other by auxiliary spring tension when they are engaged in the closed position.

Normally, the auxiliary switches have alternate make and break contact when the breaker is in the open or closed position. These can be changed, however, to give

② Twelve auxiliary switch circuits are available on the types DB-50, 75 and 100 breakers.

Mountings and Enclosures

Mountings

The type DB circuit breakers are available for dead front fixed mounting or for drawout mounting in individual enclosures or in metal enclosed switchgear assemblies.

Enclosures

Breakers applied in hazardous locations with explosive atmospheres or otherwise contaminated atmospheres, should be provided with proper enclosures to prevent explosions and to maintain proper breaker performance. Individual circuit breakers of the type DB can be supplied with enclosures as shown by the following table:

Type DB Air Circuit Breakers

For Applications up to 600 Volts Ac

Table G: Individual Enclosures for Types DB-15, 25, 50, 75 and 100 Low-Voltage Air Circuit Breakers

Enclosure	Description	Applications
General Purpose (Ventilated)	An indoor enclosure with louvres, designed to enclose the breaker so as to prevent accidental contact with the enclosed apparatus.	Indoor applications with normal atmospheric and service conditions.
Semi Dust-tight	An indoor enclosure, less louvres, with a gasketed front door to limit the amount of dust that may enter the enclosure.	Indoor applications where additional protection against dust or particles is desired over that provided by the general-purpose enclosure.
Dust-tight	An indoor enclosure, less louvres but suitably gasketed to exclude all falling or suspended dust or particles from entering the enclosure.	Indoor applications where the atmosphere may be contaminated by metal dust (such as aluminum or magnesium) or cement dusts. Also required for hazardous locations, classes II and III as defined by the National Electrical Code where the atmosphere may be contaminated with combustible dusts (such as in coal pulverizer plants, flour mills, grain elevators, starch plants, etc.) or atmospheres contaminated with combustible fibres (such as in cotton, rayon and other textile mills).
Explosion-proof^①	An indoor enclosure so designed to withstand an internal explosion of specified combustible mixtures without the emission of flame.	Required in hazardous locations, class I, group D, as defined by the National Electrical Code where the atmosphere may be contaminated by combustible vapors (such as gasoline, naphtha, butane, alcohol, lacquers, etc.). Explosion-proof enclosures are not suitable for hazardous locations, class I, groups A, B and C where atmospheres contain highly explosive gases such as acetylene, hydrogen gas or ethylene.
Submersible^①	An outdoor, submersible enclosure designed so that the enclosed breaker will operate successfully when the enclosure is submerged in water under specified conditions of pressure and time.	For quarries, mines or manholes requiring a submersible enclosure
Water-tight	An outdoor enclosure, suitably gasketed and designed to protect the breaker when the enclosure is subjected to water in the form of a hose stream.	Water-tight enclosures may be required such as on ship docks, and in dairies, breweries, etc.
Weatherproof	An outdoor enclosure, suitably gasketed and designed to protect the breaker against normal weather hazards such as rain, snow and sleet. The enclosure may be provided with breather vents to eliminate condensation.	For outdoor applications where the enclosure is subjected to normal weather conditions.

^① These standard enclosures are not available for Type DB-15 breaker.

Refer to the nearest Westinghouse district office for other special enclosures.

Note: All individual enclosures, except the general purpose ventilated enclosure tend to restrict and prevent adequate ventilation hence the maximum continuous current that the enclosed breaker can carry is limited as follows:

For type DB-50 the maximum continuous current should not exceed 1200 amperes.

Selective Tripping^②

Selective tripping is the application of circuit breakers in series so that of the circuit breakers carrying fault current, only the one nearest the fault opens and isolates the faulted circuit from the system. This type of system gives maximum continuity of service. The following requirements should be observed:

1. Each circuit breaker must have an interrupting rating equal to or greater than the short-circuit current available at the point of application.
2. Each circuit breaker, equipped with selective tripping devices, must have a short-time rating equal to or greater than the short-circuit current available at the point of application. This does not apply to feeder breakers having instantaneous overcurrent tripping devices.

3. The tripping characteristics of each circuit breaker overcurrent device must be so selected that the breaker nearest the fault opens to clear the faulted circuit. Breakers nearer the source of power should remain closed and continue to carry their respective loads. To accomplish this selectivity, the tripping characteristics of the breaker overcurrent devices should not overlap.

4. Dependent manually operated circuit breakers shall be limited to applications in which the delayed tripping requirements do not exceed 14,000 sym. rms amperes. In other words, breakers having short-delay overcurrent tripping that are applied to systems where the available short-circuit current is above 14,000 sym. rms amperes shall have electrically operated mechanisms or independent manual (spring closing) mechanisms.

5. A maximum of four low voltage air circuit breakers can be operated selectively in series, one of these being a feeder breaker with instantaneous overcurrent tripping.

6. Attention is directed to the fact that selective tripping requires coordination with the rest of the system; for instance, circuit breakers on the low voltage side of a transformer bank require proper coordination with relays or fuses on the high voltage side.

7. It is important that the selective tripping requirements be considered in the initial design of the system. The distribution of load should be such that the relative continuous current ratings of the various breakers (trip coil ratings of their overcurrent tripping devices) can give the required selectivity. To illustrate the point, refer to the selective tripping examples on

^② Essential text of related sections of NEMA standard SG-3 and AIEE standard No. 20.

Westinghouse



pages 12, 15 and 18. Note that the current ratings of the largest group feeder and feeder breakers were limited to certain values in order to obtain selectivity. The relative current ratings shown in the examples may be used as a general guide; however, in some cases other ratings may be used.

Figure 2: Transformer bank with primary fuses

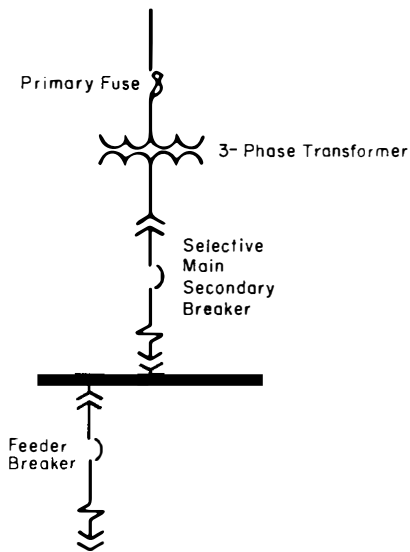

Coordination with Fuses – See Figure 2. A fuse current rating of approximately 200 percent of the transformer rated current (based on the transformer self-cooled rating) will in general override the transformer magnetizing inrush current and provide adequate fault protection.

In a selective trip system, the transformer main secondary breaker should be of the selective type; that is, equipped with series overcurrent tripping devices having long- and short-delay characteristics. The devices should be selected and set to meet the following requirements.

1. Furnish overload protection for the transformer.
2. Furnish short-circuit and arcing-fault protection for the bus and feeder breakers.
3. The transformer main secondary breaker should be selective with the feeder or group feeder breakers; that is, the time current characteristics of their respective series overcurrent devices should not overlap.
4. The secondary main breaker should give the best possible coordination with the primary fuses. To ensure safe selective tripping between the primary fuse and a main

secondary breaker (that is, where the breaker is able to clear a secondary fault before there is any risk of damaging the fuse thermally), the total clearing time of the breaker should lie below the short-time curve of the fuse for all values of current equal to and less than the maximum value of symmetrical fault current that can flow through the transformer to a secondary fault[ⓐ].

If some overlap of the breaker and fuse curves cannot be avoided, then it is desirable to set the breaker such that the breaker will always trip even though the fuse may be damaged thermally. This can be accomplished by keeping the total clearing time of the breaker below the minimum melting time curve of the fuse.

Complete selectivity (that is, no overlapping of the characteristic curves) between the primary fuses and the secondary main breaker is desirable, but is generally difficult to obtain because of the extreme differences in their characteristic curves. The current rating of the fuse should not be arbitrarily increased to give complete selectivity at the expense of sacrificing adequate protection.

On applications where some overlap cannot be avoided, it is recommended that the primary fuses should be replaced as a matter of operating procedure whenever the secondary main breaker trips for a bus fault, as there is the possibility of damaging, and still not blowing, the fuses. Again, since bus faults are rare, particularly in enclosed switchgear assemblies, the probabilities of this condition ever occurring are very low.

Group feeder and feeder breakers off the main bus should be selected and set to give complete selectivity with the transformer primary fuses.

Selective Tripping, Example 1: Low Voltage Transformer Installation With Primary Fuses

Assume a 480-volt, low voltage system as shown in Figure 3, page 13.

1. Continuous Current Ratings:

- a. Primary Fuse: The transformer rated current on the primary side is 104 amperes. A 200-E fuse would normally be supplied.
- b. Selective Main Secondary Breaker: The transformer rated current on the low

[ⓐ] The short-time curve of the fuse will lie below the main melting time curve and takes into account such factors as preloading and gives adequate margin for coordination purposes. Some manufacturers do not give short-time curves of their fuses; in these cases it is recommended that the total clearing time of the low voltage breaker not exceed 75 percent of the time indicated by the minimum melting time curve of the primary fuse.

voltage side is 900 amperes. A 1200 ampere breaker is required; this inherently requires a Type DB-50 breaker.

- c. Selective Group Feeder Breakers: It is assumed that the largest selective group feeder breaker required is rated 600 amperes.
- d. Feeder Breakers at Control Center Bus: It is assumed that the largest feeder breaker required is rated 150 amperes.

2. Interrupting and Short-Time Current Requirements:

- a. Primary Fuse: It is assumed that the primary system short circuit Kva available will not exceed approximately 150,000; hence, a type BA-400 fuse is adequate.

- b. Selective Main Secondary Breaker: From Table D, page 5, the combined short-circuit current at the bus is approximately 18,000 amperes (sym. rms). A type DB-50 breaker was selected on the basis of continuous current requirements, however, both the interrupting and short-time current ratings are also adequate.

- c. Selective Group Feeder Breaker: The type DB-25 breaker has an interrupting rating of 30,000 amperes at 480 volts and a short-time rating of 22,000 amperes and hence is adequate. Note that type DB-15 breakers have an interrupting rating of 22,000 amperes at 480 volts and if equipped with long delay and instantaneous overcurrent trip devices, the short-time current rating need not be considered. Thus, feeder breakers on the main bus, equipped with long delay and instantaneous trip could be DB-15 breakers.

- d. Feeder Breakers at Control Center Bus: It is assumed that there is sufficient cable impedance to limit the available short-circuit current at the control center to 14,000 amperes. Hence, type AB molded case breakers, frame size F and larger, are applicable.

Type DB Air Circuit Breakers

For Applications up to 600 Volts Ac

Figure 3: Selective Tripping Time-Current Characteristic Curves for the Low Voltage Transformer Installation with Primary Fuses

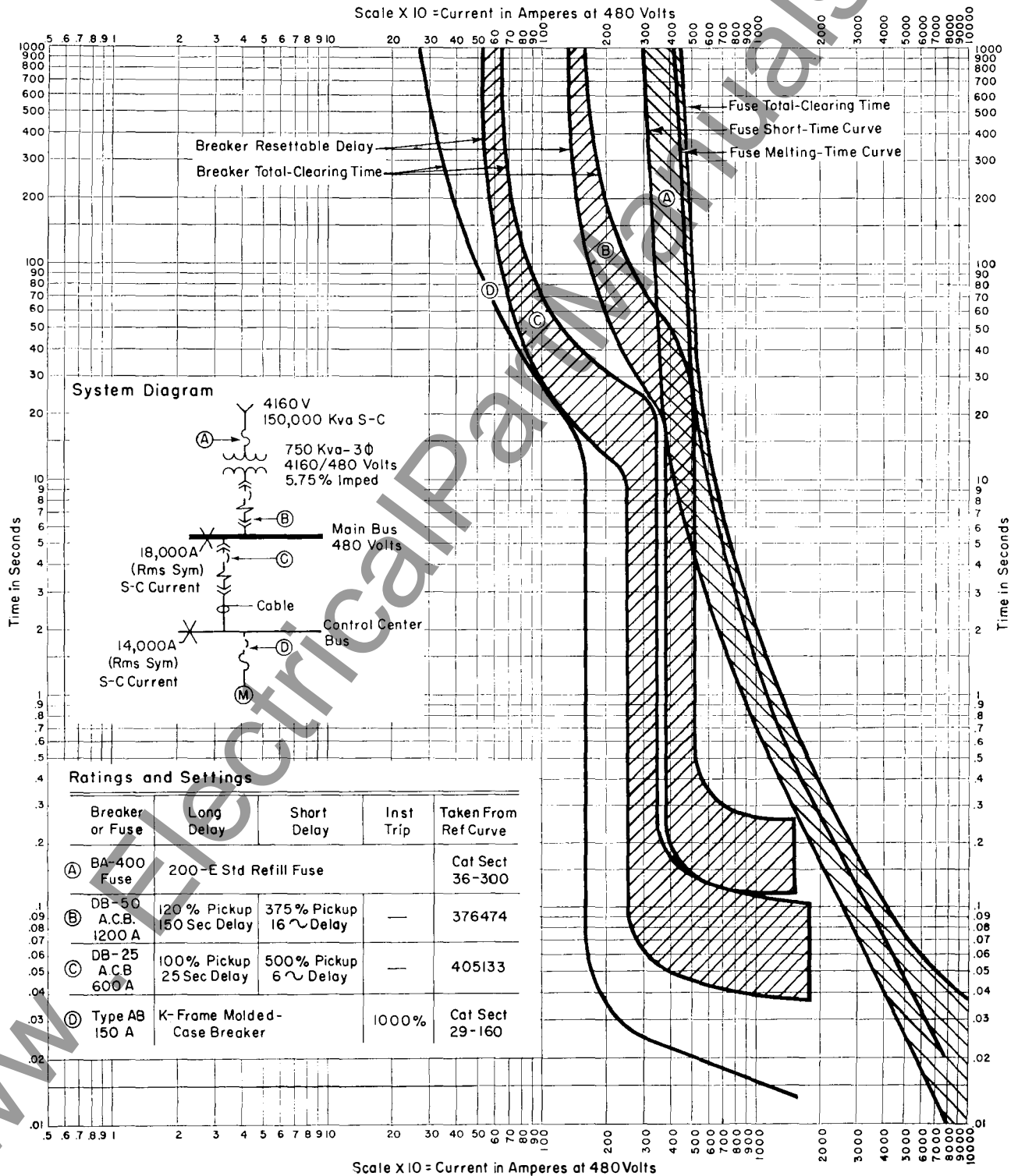

Westinghouse



3. Tripping Characteristics:

- a. **Primary Fuse:** The primary fuse has a characteristic band made up of the short-time and total clearing time curves. The fuse gives short-circuit protection to the transformer and also gives arcing fault protection to the transformer secondary and the circuit connection to the low voltage switchgear.
- b. **Selective Main Secondary Breaker:** The main secondary breaker should have series overcurrent tripping devices of the long and short delay type to give selectivity with the group feeder breakers. The characteristics were selected so that even though there is slight overlapping with the primary fuse, the total clearing time of the breaker does not exceed the melting time curve of the fuse. This insures that the breaker will always trip for bus faults. Note that there is selectivity in the range of probable fault currents^① and that the only overlap is in a small range of overcurrents that are considerably above normal overloads and yet below the probable short-circuit currents; hence, the overlap is actually insignificant. The characteristics were taken from curve number 376474. The secondary breaker also gives overload protection to the transformer as it is set to pick up at 1400 amperes, or 160 percent of the transformer rated current (the National Electrical Code allows a maximum setting of 250 percent). The low, short delay pick-up setting insures quick clearing over a large range of fault currents; hence, giving good arcing fault protection to the bus and group feeder breakers.
- c. **Selective Group Feeder Breaker:** The series overcurrent tripping devices are of the long and short delay type to give cable protection and selectivity with the load breakers. The group feeder breakers are completely selective with the primary fuses and the main secondary breaker. The characteristics were taken from curve number 405133.
- d. **Feeder Breaker:** The characteristics of a standard type AB molded case breaker are shown as taken from Application Data 29-160, "De-ion[®] Circuit Breakers."

^① From Table D, page 5, the rms symmetrical current from the transformer alone is 14,400 amperes.

At this value of symmetrical current, the total clearing time and the primary fuse short-time curve just touch.

Coordination with Relays -

See Figure 4

Normally, one or both windings of the transformer will be delta connected; hence, the high and low voltage systems will be iso-

lated from the standpoint of ground fault currents. Therefore, coordination between low voltage breakers and ground relays on the high voltage system is generally not considered.

Consideration must be given to the proper selection of the current transformer ratios and types of available relays. Generally, the primary rating of the current transformers on the high voltage side should be about 200-250 percent of the power transformer rated current.^② Overcurrent relays of the 4-12 (or 4-15) ampere range, with 40-160 ampere range instantaneous trip attachments, are usually satisfactory.

The instantaneous trip attachments provide high speed tripping for transformer primary faults. The pickup setting of the attachment should be sufficiently high^③ to override the current flowing through the transformer (including asymmetry) during a low voltage system fault.

Figure 4: Transformer Bank with High-Side Relays

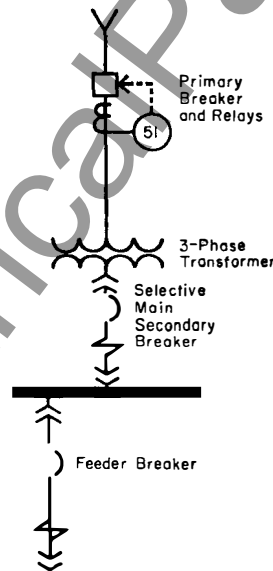

The main transformer secondary breaker should be equipped with series overcurrent tripping devices of the long and short delay type that meet the following requirements:

1. Provide overload protection for the transformer.
2. Provide short-circuit and arcing fault protection for the bus and feeder breakers.
3. Furnish selective tripping with the group feeder and feeder breakers.
4. Give the best possible coordination with the primary relays.

^② When there is no main transformer secondary breaker, the primary current rating of the current transformers should not exceed approximately 200 percent of the power transformer rated current.

^③ The minimum setting is 1.6 times the symmetrical ac current flowing on the high voltage side (in terms of the current transformer secondary) for a bolted, 3-phase short-circuit on the low voltage side.

Type DB Air Circuit Breakers

For Applications up to 600 Volts Ac

Selective Tripping, Example 2: Low Voltage Transformer Installation with Primary Relays

Assume a 480-volt, low voltage system as shown in Figure 5, page 16.

1. Continuous Current Ratings:

- Primary Relays:** The transformer rated current on the high side is 41.6 amperes. Assume a 100/5 ratio current transformer and 4-12 ampere range type CO relays.
- Selective Main Secondary Breaker:** The transformer rated current on the low voltage side is 1200 amperes, thus a type DB-50, 1600 ampere breaker is selected.
- Selective Bus Tie Breaker:** A 1600 ampere, type DB-50 bus tie breaker is selected.
- Selective Group Feeder Breakers:** It is assumed that the largest feeder breaker required is rated at 600 amperes.
- Feeder Breakers at Control Center Bus:** It is assumed that the largest feeder breaker required is rated at 150 amperes.

2. Interrupting and Short-Time Current Requirements:

- Primary Breakers:** Based on a projected future available short circuit kva of 500,000, the type 150 DHP 500 breakers are adequate.
- Selective Main Secondary Breakers:** From Table D, page 5, the combined short-circuit current at each bus section with the bus tie breaker open is 25,000 amperes (rms sym.). The interrupting and short-time ratings of the DB-50 main breakers are adequate.
- Selective Bus Tie Breaker:** When the bus tie breaker is closed, it will not be subjected to fault current in excess of the combined short-circuit current of either bus section, namely 25,000 amperes. Hence, the DB-50 bus tie breaker has adequate interrupting and short-time ratings.
- Selective Group Feeder Breakers:** The type DB-50 breaker has an interrupting rating of 50,000 amperes at 480 volts and a short-time rating of 42,000 amperes and hence is adequate, based on a normally open bus tie breaker. Note that for feeder breakers on the main bus, type DB-25 breakers (equipped with instantaneous overcurrent trips) would have adequate interrupting capacity, and the short-time current rating need not be considered. Thus, feeder breakers on the main bus could be type DB-25 and

selective group feeder breakers must be type DB-50.

- Feeder Breakers at Control Center Bus:** It is assumed that there is sufficient cable impedance or reactors to limit the short-circuit current at the control center bus to 22,000 amperes, which, on this basis, allows the use of the type DB-15 feeder breakers.

3. Tripping Characteristics:

- Primary Relays:** The tap setting was chosen to give selectivity with the DB-50 secondary breaker. On the example curve, all currents are referred to the 480-volt side of the transformer, hence, a relay tap setting of 8 amperes, when referred to the low voltage side becomes:

$$\begin{aligned} \text{tap setting} \times \text{CT ratio} \times \frac{\text{primary voltage}}{\text{secondary voltage}} \\ = 8 \times \frac{100}{5} \times \frac{13,800}{480} \\ = 4600 \text{ amperes} \end{aligned}$$

The time lever setting was selected to give adequate time delay to allow the DB-50 secondary breakers to clear low voltage faults. However, the time lever should be kept low to give the best possible arcing fault protection.

The instantaneous trip attachment on the relay is necessary to give high speed clearing of faults on the high voltage side. The instantaneous trip setting must be high enough to override low voltage faults (including asymmetry). The setting was calculated as follows:

From Table D, page 5, the short-circuit current flowing through the transformer is 20,200 amperes.

To override a low voltage fault, the minimum instantaneous trip setting allowable is:

$$1.6 \times 20,200 = 32,320 \text{ amperes.}$$

Allowing for a 10 percent tolerance, this becomes:

$$\frac{32,320}{.9} = 35,900$$

In terms of actual relay current, this is:

$$\frac{35,900}{\frac{100}{5} \times \frac{13,800}{480}} = 62 \text{ amperes}$$

- Selective Main Secondary Breakers:** The overcurrent devices were selected with long- and short-delay tripping characteristics to obtain selectivity with the feeder breakers. The characteristics were taken from curve no. 376474. Note that

the low, short delay pickup gives good arcing fault protection to the bus and feeder breakers. The long-delay pickup was set at 100 percent of the breaker rating (1600A ampere) which corresponds to 133 percent of the transformer rated current.

- Normally Open Bus Tie Breaker:** Selectivity between the main transformer secondary breakers and the bus tie breaker is not always possible to obtain without a sacrifice in protection. To obtain this selectivity in this example would have forced higher pickups and longer time delays on both the secondary breakers and primary relays. However, as the bus tie breaker in this case is normally open, the selectivity is not considered imperative. The tripping characteristics were made the same as those of the secondary breaker so that the bus tie breaker is selective with the group feeder breakers whenever it is closed.

With a normally closed bus tie breaker (to have bus tie breaker normally closed, the interrupting rating of feeder breakers must be adequate), selective tripping between both the main transformer secondary breakers, the bus tie breaker and group feeder breakers may be desired. The continuous current ratings of the bus tie breaker and group feeder breakers must be selected and limited to such ratings that can give selectivity. If selectivity for transformer faults is also required, then sensitive directional relays on the secondary breakers would be required.

Westinghouse



Figure 5: Selective Tripping Time-Current Characteristic Curves for Low-Voltage Transformer Installation with Primary Relays

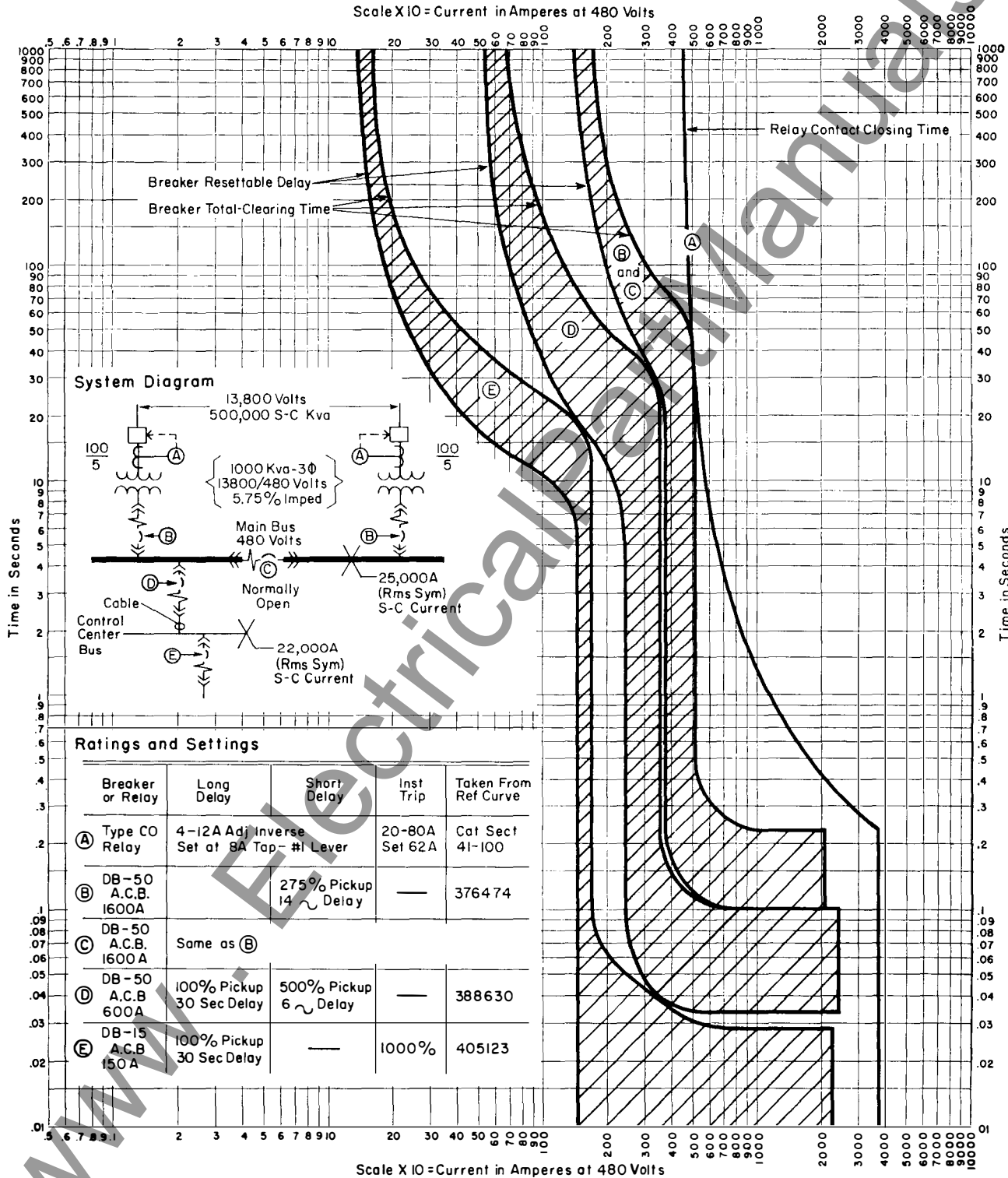

Type DB Air Circuit Breakers

For Applications up to 600 Volts Ac

- d. Selective Group Feeder Breakers: Series overcurrent tripping devices with both long and short delay are necessary to give cable protection and selectivity with the feeder breakers at the Control Center. The characteristics shown were taken from curve no. 388630.
- e. Feeder Breakers at the Control Center Bus: The type DB-15 feeder breaker is shown with long delay and instantaneous trip characteristics. The curve was taken from curve no. 405123.

Main Transformer Secondary Breakers

In low voltage transformer installations, the need for a main transformer secondary breaker is dependent upon both the high and low voltage system design and layout. The following are some of the more common conditions for which a main transformer secondary breaker is generally recommended:

1. When the transformer primary protection is furnished by fuses. A main transformer secondary breaker also facilitates interlocking with primary disconnect switches.
2. When the transformer primary breaker is located a considerable distance from the low voltage installation.
3. When the low voltage system is connected to other major sources of supply such as through a bus tie breaker in double ended power centers.

The condition for which a secondary breaker would not be necessary would be for a low voltage installation fed by a single transformer bank with a primary breaker in close proximity.

Main transformer secondary circuit breakers should in general have a continuous current rating approximately 25 to 33 percent greater than the transformer rated current. This is recommended since transformers often carry short-time loads above their rating due to short duty cycles and low ambient temperatures. Exceptions to this general recommendation are allowed when, in order to comply with it, the next larger standard frame size breaker is required which would result in an increase in space requirements and cost. For example, refer to Table B, page 4, the full load current of a 500 kva transformer bank at 208 volts is 1388 amperes. A type DB-50 breaker would normally be supplied having a current rating of 1600 amperes, i.e., 15% greater than the transformer rated current.

Consideration should also be given to whether or not the transformer will have in the future a continuous forced, air-cooled rating. If a future forced, air-cooled rating

is anticipated, the breaker current rating should be 25 to 33 percent above the continuous forced, air-cooled rated current.

Directly Connected Generation on the Low Voltage System

Occasionally, the main source of power on a low voltage system may be in the form of directly connected generation. A typical case is the electrical system of ships where the generation, distribution and load are all at the same low voltage. The following paragraphs outline the factors that should be considered in the selection of the breakers and their overcurrent devices.

The generator breaker current rating should be near 125 percent of the generator rated current. (Note: The breaker current rating should not exceed approximately 125 percent as to do so, will make adequate short-circuit protection difficult to obtain). The series overcurrent tripping device should have both long- and short-time delay characteristics such as shown by curve no. 376474.

Long Time Delay Overcurrent Protection: Most generators have a 25 percent, 2 hour overload rating, hence the current pickup setting of the long delay element should be between 125-150 percent of the generator rated current to prevent excessive temperature rise of the generator for conditions of extreme overload. The time delay setting should be selected to give the required selectivity with other breakers.

Short Time Delay and Back-up Fault Protection: The short-circuit current from a generator is initially a large value determined mainly by the machine subtransient reactance and impedance from the generator to the point of fault. This current decays with time and reaches a lower sustained value that is dependent on such factors as the machine synchronous reactance and the characteristics of the excitation system of the generator. A curve of short-circuit current versus time, showing the initial magnitude of fault current, the rate at which it decays and its sustained value, is called a decrement curve.

The decrement curve for a particular machine is generally not available; however, the two most important points can be obtained from the machine manufacturer; namely,

1. the initial value of short-circuit current which is calculated from the machine subtransient reactance and which determines the circuit breaker interrupting requirements,
2. the sustained 3-phase short-circuit current which is important in selecting the

proper characteristics and setting for the generator overcurrent device.

The sustained value of short-circuit current should be based on the following conditions:

1. 3-phase fault
2. maximum field excitation due to automatic voltage regulator action (field forcing condition)
3. field at normal operating temperature (hot)

With the usual generator and excitation characteristics, the sustained value of 3-phase short-circuit current is generally 2.5 to 3 times the generator rated current. With manual voltage control, the value may be .8 to 2 times rated current depending on the load prior to the fault, however, automatic voltage control is the more common condition.

Note: The sustained value of current for a line-to-line fault will be greater than the sustained value for a 3-phase fault. Also, fault resistance usually has very little effect on the magnitude of sustained fault current because of the high synchronous reactance of the generator

In view of the above factors, it is usually recommended that the short-delay pickup setting not exceed approximately 80 percent of the sustained generator fault current (as defined above). The time setting should be selected to give the required selectivity with other breakers.

When generators are operated in parallel with other power sources, they are frequently equipped with reverse power protective relays. Also, the prime movers are usually equipped with overspeed trip devices. Therefore, the generator breaker should be equipped with a shunt trip device so that either the reverse power relay or the overspeed trip device can trip the breaker. (Use dc battery supply or ac source for shunt trip; it is not good to use generator exciter voltage, as both prime mover and excitation may be lost.)

When low voltage breakers in excess of 3000 amperes are required, it is recommended that type COV relays[Ⓛ], current transformers and shunt trips be used. A 2-6 ampere range relay is generally satisfactory.

[Ⓛ] The type COV relay is a voltage controlled overcurrent relay consisting of an induction disk overcurrent element and a supervising voltage element. The overcurrent element can be set to operate on less than generator full-load current when the voltage falls below the setting of the voltage element. However, the overcurrent element will not operate if the voltage is normal or above the predetermined value as would be characteristic of load swings or the starting of large motors.

Westinghouse



Selective Tripping, Example 3:

Low Voltage Generator Installation

Assume the 450-volt turbine generator installation as shown in Figure 6, page 19.

1. Continuous Current Ratings:

- a. Selective Generator Breakers: Each 750 Kva generator has a continuous current rating of:

$$\frac{750}{\sqrt{3} \times 450} \times 1000 = 960 \text{ amperes}$$

Hence, 1200 ampere rated breakers are required.

- b. Selective Group Feeder Breakers: It is assumed the largest group feeder breaker required is rated 600 amperes.
- c. Feeder breakers at Control Center Bus: It is assumed that the largest feeder breaker required is rated 100 amperes.

2. Interrupting and Short-Time Current Requirements:

The value of fault current is the sum of the fault current contributions of the two generators and motor feedback from an assumed 100 percent motor load.

- a. Selective Generator Breakers: Type DB-50 breakers were selected on the basis of the continuous current requirements. The breakers also have adequate interrupting and short-time current ratings.
- b. Selective Group Feeder Breakers: Although available symmetrical short-circuit current is below the short-time rating of DB-25 breakers (21,900 amps against 22,000 amps), this breaker cannot be used as a selective group feeder breaker, because X/R ratio is 20, which is much more than 6.6. From figure 19 on page 35 for X/R=20 average asymmetry factor is 1.31. therefore the total asymmetrical short-circuit current avail-

able is $1.31 \times 21,900 = 28,700$ asymmetrical rms amps. This is above the asymmetrical short-time rating of DB-25 breaker, hence DB-50 selective group feeder breakers are required.

Note: Type DB-25 breakers have an interrupting rating of 30,000 amperes at 480 volts, and if equipped with long delay and instantaneous overcurrent trip devices, the short-time current rating need not be considered. Thus, feeder breakers on the main bus, equipped with long delay and instantaneous trips may be type DB-25 breakers.

- c. Feeder Breakers at the Control Center Bus: It is assumed there is sufficient cable impedance to limit the short-circuit current at the control center bus to 14,000 amperes, thus allowing the use of type AB molded case breakers, frame sizes F or larger

3. Tripping Characteristics:

- a. Selective Generator Breakers: Series overcurrent tripping devices of the long and short delay type are required to give selectivity with group feeder and feeder breakers. In order to set the short delay pickup less than the sustained fault current of the generator as shown by the generator decrement curve, the tripping characteristics were taken from curve no. 376474.
- b. Selective Group Feeder Breakers: Long and short delay series overcurrent tripping devices are required to give cable protection and selectivity with the feeder breakers. The characteristics are taken from curve no. 376474.

- c. Feeder Breakers: The characteristics of a standard type AB molded case breaker are shown as taken from Application Data 29-160, "De-ion Circuit Breakers".

② Other protective devices or relays may be required for generator protection such as differential relays or high-speed directional relays for internal fault protection, or other relays for loss of field protection and anti-motoring protection. The application of these relays depend on the degree of protection desired, the size of the machine and its relative importance in maintaining system operations.

Type DB Air Circuit Breakers

For Applications up to 600 Volts Ac

Figure 6: Selective Tripping Time-Current Characteristic Curves Low-Voltage Generator Installation

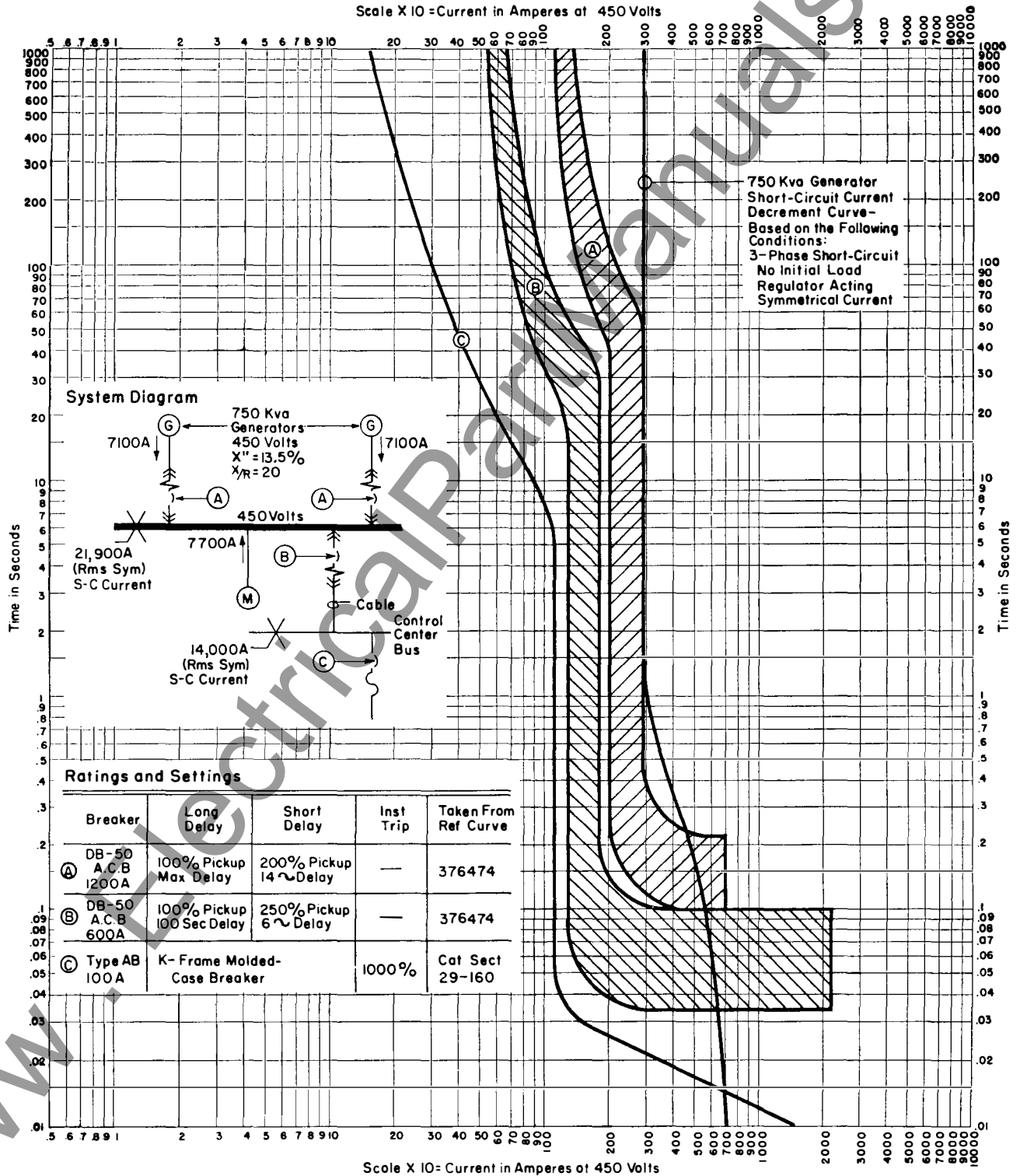

Westinghouse



Arcing Fault Protection

The presence of fault or arc impedance can appreciably reduce the available short-circuit current of a low voltage system. Because the current limiting effects of arc impedance are inconsistent, the reduction in short-circuit current cannot be accurately predicted. Past experience and testing, however, have indicated that arcing fault currents may be as low as 50 percent of the calculated, bolted short-circuit values; thus fault currents on low voltage systems are expected to fall in a range from the maximum bolted 3-phase short-circuit value down to 50 percent of that value. The selection and settings of the breaker over-current tripping devices should be made to secure proper protection over this range of expected fault currents.

Adequate arcing fault protection can generally be obtained from series overcurrent tripping devices when the short delay or instantaneous trip element is set to pick up at approximately 50 percent or less of the calculated short-circuit current (symmetrical rms value) flowing in the circuit.

In order to obtain an instantaneous pickup setting low enough to provide adequate arcing fault protection, breakers used for incoming line and transformer secondary application have been provided with a 500% minimum setting instead of the 800% minimum usually found on feeder breakers.

Breakers with the following characteristics are considered standard for incoming line or transformer secondary application in non-selective systems.

- DB-15 and DB-25 curve 351056
- DB-50 curve 351057
- DB-75 and DB-100 curve 351058

Transformer primary fuses and relays must furnish adequate arcing fault protection for the transformer secondary and the connecting circuit to the low voltage switchgear. In these cases, the fuses or relays should operate in as short a time as possible (generally not more than a few seconds) for arcing fault currents as low as 50 percent of the calculated short-circuit current (symmetrical rms value) flowing through the transformer during a low voltage fault. Refer to selective tripping, examples 1 and 2, pages 13 and 16 respectively.

* Cascading is no longer a recognized arrangement. See ANSI - C 37.16 - 1970.

Cascade Arrangements*

Cascading is the application of circuit breakers in which the breakers nearest the source of power have interrupting ratings equal to, or greater than, the maximum available fault current, and where one or more breakers further removed from the power source have interrupting ratings less than the maximum available fault current at the point of their application.

In the cascade arrangements, circuit breakers toward the source of power are provided with instantaneous tripping for currents that may flow for faults beyond other circuit breakers nearer the load. Hence, the main breaker (or group feeder breaker as the case may be) may trip for a feeder fault and interrupt load on the remaining feeder circuits. Such arrangements are used where the possible sacrifice in service continuity and possible damage to equipment are acceptable.

Cascading is limited to one step as shown in the following figures and as outlined in the following paragraphs:

1. The interrupting rating of the circuit breaker or breakers nearest the source should be equal to, or exceed, the maximum available fault current that it may be required to interrupt.

This applies to breakers M, F and GF in figure 7. These breakers must be equipped with instantaneous series overcurrent tripping devices.

2. The source breakers (breakers M and GF) must give backup protection to the cascaded feeder breakers. To accom-

plish the backup protection, the instantaneous series overcurrent tripping devices on the source breakers must be set at such a value of current that the source breakers are tripped instantaneously whenever the fault current through the cascaded feeder breaker exceeds 80 percent of interrupting rating of the cascaded feeder breaker.

- 3 The cascaded feeder breakers (CF) should be selected so that the maximum available fault current at that point does not exceed the breaker cascade application limit shown in Table H. The breakers should be equipped with instantaneous trips set to override the inrush of the load.
4. All circuit breakers subjected to fault currents in excess of their interrupting rating should be electrically operated

Figure 7: Basic Cascade Arrangements

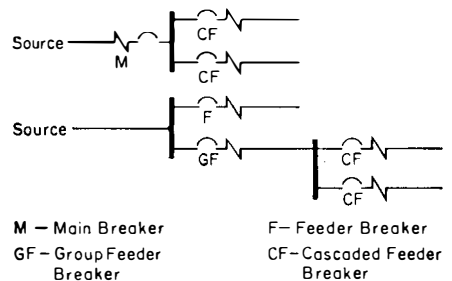

M - Main Breaker
GF - Group Feeder Breaker
F - Feeder Breaker
CF - Cascaded Feeder Breaker

Table H: Fault Current Limits for Cascading

System Nominal Voltage①	Breaker Type	Interrupting Rating		Limit of Fault Current at Which Breaker May be Applied When Cascaded	
		Asymmetrical Rms Amperes	Symmetrical Rms Amperes	Asymmetrical Rms Amperes	Symmetrical rms Amperes
600-481	DB-15	15000	14000	30000	25000
	DB-25	25000	22000	50000	42000
	DB-50	50000	42000	100000	85000
	DB-75	75000	65000	100000	85000
	DB-100	100000	85000	100000	85000
480-241	DB-15	25000	22000	50000	42000
	DB-25	35000	30000	70000	60000
	DB-50	60000	50000	100000	85000
	DB-75	75000	65000	100000	85000
	DB-100	100000	85000	100000	85000
240 and Below	DB-15	30000	25000	60000	50000
	DB-25	50000	42000	100000	85000
	DB-50	75000	65000	120000	100000
	DB-75	100000	85000	150000	130000
	DB-100	150000	130000	150000	130000

① For frequencies less than 50 cps use the current value in the 600-481 volt block.

Type DB Air Circuit Breakers

For Applications up to 600 Volts Ac

from a remote position only, to provide protection for the operator in the event of closing into a fault. In switchgear assemblies, it is permissible to locate the breaker control switch or push button on an adjacent unit.

- Where cascading is proposed, recommendations shall be obtained from the manufacturer in order to insure proper coordination between circuit breakers.
- The operation of circuit breakers in excess of their interrupting rating is limited to one interruption, after which inspection, maintenance, or complete breaker replacement may be required.
- Molded case circuit breakers are not recommended for use in cascade with air circuit breakers of a nonmolded case design.

The following formula may be used to select the maximum setting of the instantaneous trips of the source breaker or breakers.

$$\left(\begin{array}{l} \text{setting of source breaker} \\ \text{with contribution of F} \\ \text{fault amperes} \end{array} \right) = \frac{F}{\text{Total}} .8 (IR)$$

F— Fault current contribution from the power source being considered (rms symmetrical amperes)

IR— Interrupting rating of cascaded feeder breaker.

Total— Total fault current (rms sym. amperes) which the cascaded feeder breakers are subjected to, including motor feedback from other feeders on the bus.

The above formula is particularly helpful when there is more than one power source contributing fault current such as shown in figure 8.

Figure 8: Example Cascade Arrangement with Two Sources

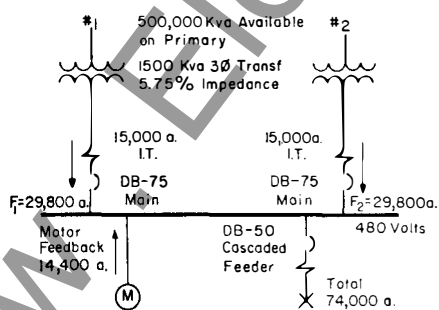

In this example, the DB-75 main breaker of source no. 1 should have its series instantaneous trips set at not more than —

$$\frac{29,800}{74,000} .8 (50,000) = 16,200 \text{ amperes}$$

In this particular case the instantaneous trips of DB-75 main breakers should not be set higher than $29,800/2=15,000$ A. (See arcing fault protection on page 20.)

Since both sources are identical and the fault contributions are the same, both main breakers should have the same settings.

Comparison of Selective Tripping and Cascading

A selective trip system should be recommended where the greatest possible continuity of service is required, such as for powerhouse auxiliaries, hospitals and continuous industrial processes. Where continuity of service is not important, the cascade system is applicable. It should be noted that, in general, the initial cost of a cascade system is lower than an equivalent selective trip system, as the cascade system utilizes breakers with interrupting capacities below the available short-circuit currents. However, in the cascade system, consideration should be given to increased maintenance costs and the loss of production due to a possible shutdown.

Motor Circuit Protection Breaker Interrupting Capacity

The interrupting rating of the circuit breaker should be adequate, based on the available short-circuit current at the point of application.

Breaker Continuous Current Rating

In all cases, the breaker continuous current rating must be at least 115 percent of the motor rated full-load current.

When the circuit breaker is used for motor running overcurrent protection, it is recommended that the breaker current rating fall in the range of 115-156 percent of motor rated full-load current. Refer to Table I, page 22. Where standard breaker ratings do not fall in the above range, the next higher standard rating may be used. In all cases, the setting of the overcurrent device must not exceed 140 percent of motor full-load current, for 40 degrees C rise motors and 130 percent for all other motors. In general, a setting of 125 percent of motor rated full-load current is adequate for running overcurrent protection.⓪

When used with a motor starter or controller (figure 9), where the starter furnishes the motor running overcurrent protection, a higher breaker rating and setting are permitted as shown in Table J, page 22. The basic requirements of the breaker when used with a motor starter are: (a) that the breaker furnish short-circuit protection to

the conductors, motor and starter⓪; and (b) that the breaker be capable of overriding the motor starting current. Table J shows the maximum rating or setting of the circuit breaker; however, in many cases, a lower value can be used. The current rating or setting of the breaker should not be selected unnecessarily high, as to do so, makes selective tripping with breakers closer to the source more difficult.

⓪ Breakers for the protection of fire pump circuits may require special consideration; refer to NBFU Pamphlet No. 20 for specific requirements.

ⓑ Standard motor starters are capable of interrupting only up to 10 times motor full-load current. Also fast clearing of heavy short-circuit currents is necessary to prevent damage to motor overload relays of the thermal type. These factors do not apply to combination Linestarters⓪ equipped with circuit breakers or fuses.

Westinghouse



Table I: Recommended Breaker Ratings for Full-Voltage Motor Starting and Running Duty, 40°C Rise Motors^①

Breaker Current Rating Amps	Motor Rated Full Load Current, Amps		Max. Permissible Motor Locked-Rotor Current, Amps ^①	Horsepower Rating of Three-phase Alternating-current Motors									
	Min.	Max.		Induction Motors			100% Power Factor Synchronous Motors			80% Power Factor Synchronous Motors			
				220 Volts	440 Volts	550 Volts	220 Volts	440 Volts	550 Volts	220 Volts	440 Volts	550 Volts	
15	9	13	120	3	7.5	7.5-10
20	13	17	160	5	10	15	25
30	19	26	240	7.5	15-20	20-25	...	25	30	30
40	26	35	320	10	25	30	...	30	40	40	...	25	25-30
50	32	44	400	15	30	40	...	40	50	50	30	40	40
70	45	61	560	20	40	50-60	25	50	60	60	40	50	50
90	58	78	720	25-30	50-60	75	30	60	75	75	25	50	60
100	64	87	800	40	75	100	100	30	60	80
125	80	109	1000	40	75	100	50	100	125	125	40	75	100
150	96	131	1200	50	100	125	60	100	150	150
175	112	152	1400	60	...	150	...	125	50	100	125
200	128	174	1600	...	125	...	75	150	200	200	60	125	150
225	144	196	1800	75	150	200
250	160	218	2000	100	200	250	250	75	150	200
300	192	261	2400	100	200	250	300	300
350	224	304	2800	...	250	300	125	250	350	350	100	200	250
400	256	348	3200	125	...	350	...	300	400	400	125	250	300
500	320	435	4000	150	300-350	400-450	...	350-400	450-500	450-500	...	300	350-400
600	384	522	4800	200	400	500	...	450	600	600	...	350	450
800	512	696	6400	250	450-500	600-700	...	500-600	700-800	700-800	...	400-500	500-600
1000	640	870	8000	300-350	600-700	800-900	...	700-800	900-1000	900-1000	...	600	700-800
1200	768	1044	9600	400	800	1000	...	900	700	900
1600	1023	1392	12800	450-500	900-1000	1000	800-1000	1000
2000	1280	1740	16000	600-700
2500	1600	2180	20000	800-900
3000	1920	2610	24000	1000
4000	2560	3480	32000

^① This table is applicable to circuit breakers with adjustable overcurrent tripping devices calibrated in the range of 80 to 160 percent of the breaker continuous-current rating. If the locked-rotor currents exceed the values shown, the next higher breaker rating may be used, provided the lowest setting of the breaker overcurrent device does not exceed 140 percent of motor rated full load current for 40 degree C rise motors or 130 percent for all other motors. ^② NEMA SG3-3.30

Figure 9: Breaker and Motor Starter Series

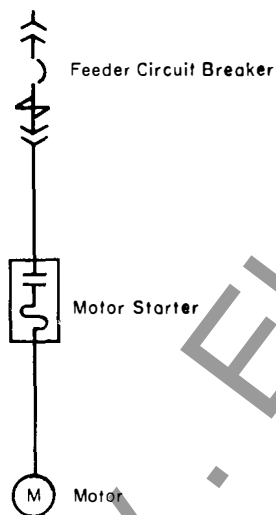

Table J: Maximum Rating or Setting of Motor Circuit Breaker^②

(When motor running overcurrent protection is furnished by some other device such as a starter)

Type and Method of Starting	Motor Code Letter(s)	Max. Rating or Setting in Percent Motor Full-Load Current
For Motors with a Code Letter:		
All ac single-phase and polyphase squirrel-cage and synchronous motors with a full-voltage, resistor or reactor starting.	A B to E F to V	150 ^③ 200 ^③ 250 ^③
All ac squirrel-cage and synchronous motors with autotransformer starting.	A B to V	150 ^③ 200 ^③
For Motors without Code Letters:		
Single-phase, all types.		250 ^③
Squirrel-cage and synchronous motors (full-voltage, resistor and reactor starting).		250 ^③
Squirrel-cage and synchronous motors (autotransformer starting).		200 ^③
High reactance, squirrel-cage motor:		
Not more than 30 amperes		250 ^③
More than 30 amperes		200 ^③
Wound-rotor motor or direct-current motor.		150 ^③
Sealed (hermetic type) refrigeration compressor 400 kva locked-rotor or less.		175 ^④

^③ These allowances may be increased up to 400 percent of motor full-load current if not satisfactory for starting; however, lower values can often be used.

^④ This value may be increased to 225 percent if necessary to permit starting.

^⑤ National Electrical Code Sections 430-52, 430-152 and 430-153.

Type DB Air Circuit Breakers

For Applications up to 600 Volts Ac

When used as a feeder for a group of motors, the rating or setting of the circuit breaker must not exceed the largest rating or setting for any motor load breaker in the group, plus the sum of the full-load currents of the other motors of the group. For large capacity installations where heavy capacity feeders are used to provide for future load increases, the group feeder breaker rating may be based on the current carrying capacity of the feeder conductors. If two or more motors are started simultaneously, it may be necessary to install larger feeder conductors and, correspondingly, group feeder breakers with larger ratings.

Figure 10: Breaker Feeding a Group of Motors

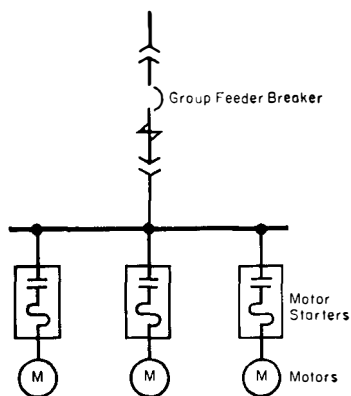

Breaker Tripping Characteristics
Series overcurrent tripping devices with long delay and instantaneous trip characteristics are generally recommended for motor breakers used for starting and running duty. The proper selection of the characteristics is dependent upon the motor starting current and the total accelerating time of the motor and its connected load.

The motor breaker must have sufficient long time delay to override the current during the motor starting period. Based on the motor locked rotor current, the total accelerating time of the motor and its connected load must lie below the resettable delay curve^① of the breaker. Refer to figure 11.

The current drawn by a motor on starting is usually several times the full-load value. It is initially the locked rotor current.^② The current decays slightly as the motor accelerates and finally drops to a steady state value corresponding to the load on the motor.

Figure 11: Coordination of Motor Starting-Current with Motor Breaker

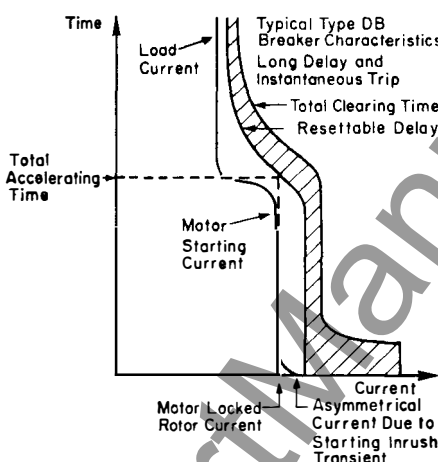

① The resettable delay curve shows the allowable duration of current flow for which the breaker will not trip if the current subsides within that time to 80 percent or less of the breaker long delay pickup setting. If the duration of current flow exceeds the time indicated by the resettable delay curve, the breaker overcurrent device may not reset and may eventually trip the breaker.

② Approximate motor locked rotor current from motor nameplate code letter. The locked kva code letter appearing on the nameplate of squirrel cage induction motors is an indication of the kva input per hp with locked rotor as shown by the following table.

Code Letter	Kva/Hp with Locked-Rotor	Code Letter	Kva/Hp with Locked-Rotor
A	0 - 3.14	L	9.0 - 9.99
B	3.15 - 3.54	M	10.0 - 11.19
C	3.55 - 3.99	N	11.2 - 12.49
D	4.00 - 4.49	P	12.5 - 13.99
E	4.50 - 4.99	R	14.0 - 15.99
F	5.00 - 5.59	S	16.0 - 17.99
G	5.6 - 6.29	T	18.0 - 19.99
H	6.3 - 7.09	U	20.0 - 22.39
J	7.1 - 7.99	V	22.4 - and up
K	8.0 - 8.99		

The maximum locked-rotor current at motor rated voltage and frequency is:

$$I_{LR} = \frac{(kva/hp) (motor-rated hp) \times 1000}{\sqrt{3} (motor rated line-line voltage)}$$

where the ratio (kva/hp) is the higher value in the table above for any given code letter.

♦ Section 430-7 of National Electrical Code (1959 edition).

Motor breakers with series overcurrent tripping devices such as shown in curves no. 405123, no. 388530 and no. 405230, are usually adequate for the general industrial applications. These devices allow total accelerating times of approximately 13 seconds for types DB-15 and DB-25 breakers and 8 seconds for type DB-50 breaker. Where the total accelerating time exceeds these values, an analysis is required to select an overcurrent device with adequate time delay that will allow the motor to come up to speed. High inertia loads, such as fans^③, certain types of pulverizers and M-G sets with large flywheels have long starting times and hence, may require motor breakers with appreciable time delay.

The full voltage starting (sometimes referred to as across-the-line starting) of large motors on a "weak" system can cause a serious low voltage condition during the starting period due to the excessive voltage regulation. The starting current of the motor decreases but the accelerating or starting time of the motor increases as a result of the low starting voltage. The actual starting current and time may be estimated from the formulas on page 24 for reduced voltage starting. The long-time delay setting of the breaker overcurrent device should be based on the actual or corrected starting current and time.

The instantaneous trip element of the overcurrent device provides short-circuit protection for the motor and conductors, but must be set to override the motor starting current, including asymmetry. The recommended minimum pickup setting is 1.5 times the motor locked rotor current (at rated voltage).

③ Certain types of fans, due to the accumulation of dirt on the blades, require an appreciably longer time to start than when clean. The fan manufacturer should be consulted for an estimate of the increased starting time. The required time delay of the breaker can be determined accordingly.

Westinghouse



**Motor Breaker, Example 1:
Breaker for Motor Starting and Running Duty**

Motor Data:

125 hp, 3-phase, 440-volt, 1200 rpm induction motor open type, 40 degree C rise, full voltage started.

full-load current=160 amperes

locked rotor current=984 amperes

total accelerating time with connected load=9 seconds

frequency of starts=4 per day

System Data:

Available short-circuit current on motor circuit is 12,500 amperes (rms symmetrical).

Breaker Selection

1. Interrupting Rating: The type DB-15 has an interrupting rating of 22,000 amperes and hence is adequate.

2. Repetitive Duty: Four starts per day is eight operations per day under inrush and nonfault conditions. Table F, page 7, shows 3500 operations without major servicing. Note that the number of operations listed in the table is based on closing currents up to 600 percent of the breaker frame size (225 amperes for type DB-15) which is 1350 amperes. The motor locked rotor current is 984 amperes, hence a greater number of operations may be expected before major servicing.

3. Current Rating: A 200 ampere rated trip coil is selected as it is 125 percent of the motor rated full-load current and is in the recommended range of 115 to 156 percent.

4. Tripping Characteristics: The breaker should be equipped with series overcurrent devices with long delay and instantaneous tripping characteristics. In this case, the breaker is to furnish motor running overcurrent protection; hence, the long delay pickup should be set at approximately 125 percent of the motor rated full-load current, or

$$\frac{125}{100} \times 160 = 200 \text{ amperes}$$

This value corresponds to a setting of 100 percent in terms of the trip coil current rating.

The motor locked rotor current of 984 amperes in terms of the trip coil rating is

$$\frac{984}{200} \times 100\% = 492\%$$

Referring to the tripping characteristics of a type DB-15 breaker with a long delay

and instantaneous overcurrent device as shown in curve no. 405123, the time delay for locked rotor current as determined by the resettable delay curve is 9.6 to 14 seconds depending on the long delay time setting. A 20-second long delay time setting is adequate to override the 9-second starting period.

The instantaneous element must be capable of overriding the maximum starting inrush current including asymmetry. The minimum permissible pickup setting that will override the starting inrush is 1.5 times the motor locked rotor current. This would be $\frac{1.5 \times 984}{200} \times 100 = 740\%$ of the trip coil rating

Taking into account the ± 10 percent tolerance in the pickup setting, the minimum setting becomes

$$\frac{740\%}{.9} = 822\%$$

As shown on the curve, the instantaneous element is adjustable with calibrated points at 800 and 1200 percent of the trip coil rating; hence, the device can be accurately set to override the starting inrush current.

Motor Locked Rotor Protection

Motor locked rotor protection can be obtained when the total clearing time of the breaker for locked rotor current is less than the maximum permissible locked rotor time as furnished by the motor manufacturer.

Complete locked rotor protection cannot always be guaranteed in all applications; however, a reasonable degree of protection can generally be obtained when the long delay time setting is set to such a value that the motor starting time and locked rotor current correspond to a point on the resettable delay curve of the breaker overcurrent device. This setting gives the best possible protection that the device is capable of furnishing. In some installations the motor is in sight of the breaker so that the operator can visually detect a locked rotor condition. It should be realized, however, that locked rotor conditions are rare and many loads are of such a nature that locked rotor conditions are, for practical purposes, not possible.

④ The motor design determines the maximum permissible locked rotor time, which, in some cases, may be even less than the normal starting time of the motor. For such cases, locked rotor protection cannot be furnished by any protective device that functions on motor current alone.

Reduced Voltage Starting

Large motors are sometimes started at reduced voltage to limit starting torques or inrush currents. Series reactors or auto-transformers are commonly used for reduced voltage starting.

Figure 12: Series Reactor Reduced Voltage Starting

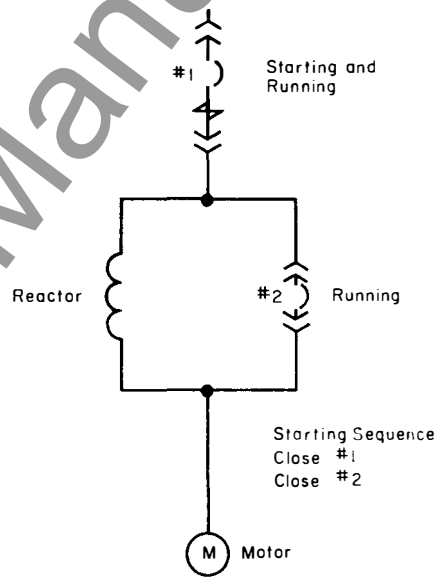

Figure 12 shows a typical scheme for reduced voltage starting. The selection of breaker no. 1 for starting and running duty is governed by the same factors as previously discussed. Additional consideration, however, should be given to the motor starting current and time as modified by the reduced voltage conditions.

The starting current drawn from the line and the starting time for series reactor, reduced voltage starting may be estimated from the following formula:

$$\text{starting current} = I_{LR} \times \frac{(V)}{100}$$

$$\text{time} = T_{RV} \times \left(\frac{100}{V} \right)^2$$

I_{LR} = motor locked rotor current in amperes at motor rated voltage (may be estimated from the motor locked kva code letter).

V = motor terminal voltage at starting in percent of motor rated voltage.

T_{RV} = starting time in seconds at motor rated voltage.

Type DB Air Circuit Breakers

For Applications up to 600 Volts Ac

The modified starting current and time should be used to determine the long-time delay setting needed to start the motor under reduced voltage conditions. The setting of the instantaneous element must still be set to override the locked rotor current for rated voltage so as to prevent false tripping during motor feedback to a fault.

The interrupting and continuous current ratings of breaker No. 2 for shorting the reactor must be the same as that of breaker No. 1. Series overcurrent tripping devices are normally omitted from breaker No. 2.

Undervoltage Protection

It is recommended that motors be automatically disconnected from the line when voltage fails. The reasons being:

a. To prevent damage to equipment and danger to personnel due to an unexpected start when voltage is restored and to prevent a large group of motors from attempting to start at the same time.

b. The simultaneous starting of a large group of motors may cause low voltage conditions which may result in the faulty starting of some motors.

Low voltage air circuit breakers used for the protection of individual motor circuits should be equipped with undervoltage tripping attachments of the time delay type. The time delay is desirable to prevent unnecessary tripping of the breaker due to momentary dips in system voltage. When the breaker is used in series with a motor starter (or controller) and when the starter provides undervoltage protection, then undervoltage tripping of the breaker can be omitted.

Undervoltage trip attachments may be omitted on breakers in metal enclosed switchgear assemblies where undervoltage tripping is obtained by means of shunt trip devices and undervoltage relays.

Resistance Welding

Low voltage air circuit breakers can also be applied on welding machine circuits for short-circuit protection of cables and welding equipment. Breakers of these applications should meet the following requirements:

1. The interrupting rating of the breakers should be equal to or greater than the available short-circuit current of the system at the point of application.

2. The breaker must have sufficient thermal capacity to prevent excessive overheating based on a given welding application.

3. The breaker should have instantaneous trip characteristics that can be set to override the normally heavy welding currents

but yet capable of instantaneous tripping under short circuit conditions.

Welding breakers are equipped with only instantaneous trips, adjustable over a wide range to override the heavy welding currents. (Long delay cannot be used because the element would pick up on every weld and quickly wear itself out. Besides it would be very noisy.)

The proper breaker for a given application can be selected from the curves and table on the next page. It is necessary to know the "during weld amperes" (or the "during weld kva"Ⓣ) and the percent duty cycle.

The "during weld amperes" is the primary current drawn from the supply circuit during each welding operation.

The percent duty cycle is the percentage of the total time not exceeding 5 minutes during which the welder is loaded, or

$$\text{percent duty cycle} = \frac{\text{weld time}}{\text{weld time} + \text{"off" time}} \times 100$$

For a given welding current and duty cycle, and for a given system short-circuit current, select the breaker(s) having adequate thermal capacity and interrupting rating from Figure 13. Then select the breaker from the table having the proper range of instantaneous trip adjustment on the basis that the instantaneous trip setting should be 1.5 times the maximum rms welding current than can be expected for the given welding application.

Ⓣ "During weld kva" is not the kva rating of the welder and must be obtained from the welder manufacturer. The "during weld amperes" may be derived from the following:
 "During weld amperes" = $\frac{\text{"during weld kva"} \times 1000}{\text{rated primary voltage}}$

Breakers for welders having series capacitors for power factor correction should be equipped with an instantaneous undervoltage device arranged with the timer cabinet door interlock to cause tripping of the breaker when the door is opened, thus protecting personnel from high voltages within the cabinet.

Resistance Welding Example:

- Welder Data: 440 volts, 60 cycles "during weld amperes" = 500
weld time = 15 cycles
welds per minute = 20
- System Data: Available short-circuit current = 20000 amperes (rms sym.)
- Breaker Selection:
 - Percent duty cycle = $\frac{15 \times 20}{60 \times 60} \times 100 = 8.3\%$
 - From the curve, for a "during weld" current of 500 amperes and a duty cycle of 8.3 percent, types DBW-15A, 15B or 25A are applicable.
 - The system short-circuit current is 20000 amperes, hence, the DBW-15A and 15B have adequate interrupting ratings.
 - A trip setting of 1.5 times 500 amperes, or 750 amperes, is required, hence, select a type DBW-15A welding breaker having an instantaneous trip range of 300-900 amperes.

Table K: Type DBW Breakers for Resistance Welding Control

Breaker Type	Continuous Current Rating (Amperes)	Interrupting Rating Rms Symmetrical (Amperes)			Instantaneous Pick-up Calibration Range and Intermediate Mark
		600 Volts	480 Volts	240 Volts	
DBW-15A	225	14000	22000	25000	300-600-900
DBW-15B	225	14000	22000	25000	800-1600-2400
DBW-25A	225	22000	30000	42000	400-800-1200
DBW-25B	600	22000	30000	42000	600-1200-1800
DBW-25C	600	22000	30000	42000	2000-4000-6000
DBW-50A	600	42000	50000	65000	600-1200-1800
DBW-50B	800	42000	50000	65000	1200-2400-3600
DBW-50C	800	42000	50000	65000	2500-5000-7500
DBW-50D	1200	42000	50000	65000	1600-3200-4800
DBW-50E	1200	42000	50000	65000	4000-8000-12000
DBW-50F	1600	42000	50000	65000	2000-4000-6000
DBW-50G	1600	42000	50000	65000	5000-10000-15000

The instantaneous trips for welding applications are calibrated at three points, covering the full range of adjustment

Westinghouse



Figure 13: Breaker Selection Maximum Loading Curves

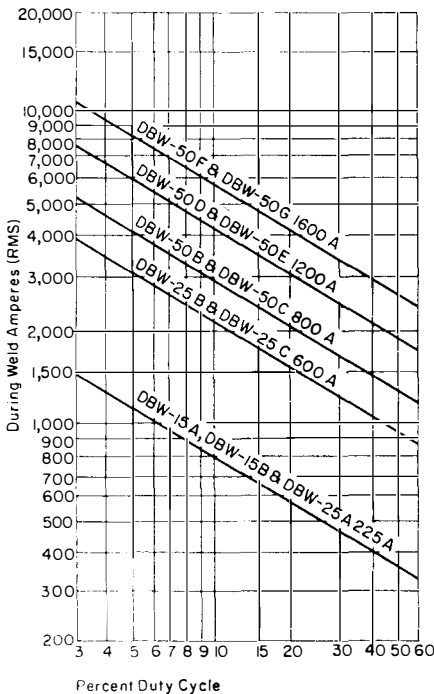

Field Discharge Breakers and Resistors

Functions of Field Discharge Breakers and Resistors

The function of a main field discharge breaker is to apply and remove excitation to the main field of a generator, motor or synchronous condenser. Main field breakers are usually required where there is more than one source of excitation. A main field breaker is also required for the starting of synchronous motors and condensers to apply excitation and remove the starting resistor from the circuit when the proper moment for field application arrives.

The function of an exciter field breaker is to apply and remove excitation to the field of an exciter. Exciter field breakers are sometimes used instead of main field breakers where there is only one source of excitation or where it is desired to make the main field circuit leads as short as possible by not using a breaker in the main field circuit.

A discharge resistor must be used with the field breaker to limit induced voltages when the breaker is opened while current is flowing in the field circuit. When the field breaker is opened, the discharge contacts of the field breaker short circuit the field

through the discharge resistor at the instant preceding the opening of the circuit breaker main contacts. Thus, the field current (stored magnetic energy) is discharged through the discharge resistor and decays to zero. A main field breaker with proper discharge resistor can produce a more rapid decay of current in the field of a machine than an exciter field breaker used in the field of the exciter of the machine. The rate of decay of field current during a fault in the armature of the machine is a factor in limiting damage at the point of fault.

The field discharge resistance is an important factor in limiting the field breaker interrupting duty and the insulation stress in the excitation system; therefore, recommendations for the selection of field discharge resistors are also included.

Selection of Field Discharge Resistors
The maximum value of the field discharge resistance may be determined from equations 1 and 2 below:

Equation 1
recommended permissible transient crest voltage^②

$$R_d = \frac{\text{recommended permissible transient crest voltage}^{\text{②}}}{K_c \times I_f}$$

Equation 2
(max. interrupting voltage rating of field breaker) - E

$$R_d = \frac{(\text{max. interrupting voltage rating of field breaker}) - E}{K_{dc} \times I_f}$$

where R_d = ohmic value of the discharge resistor.

I_f = maximum continuous field current in amperes (at maximum hydrogen pressure, if a hydrogen cooled machine).

E = excitation source rated voltage.

K_{dc} = maximum ratio of the dc component of induced field current to the maximum continuous field current (I_f), measured at 0.1 second after the inception of a fault in the armature circuit. See Table L for "maximum probable" values.

K_c = maximum ratio of the crest value of induced field current to the maximum continuous field current (I_f), measured at 0.1 second after the inception of a fault in the armature circuit. See Table L for "maximum probable" values.

The ohmic value of the discharge resistor should not exceed the lower of the two values calculated from equations 1 and 2, nor should the resistance be less than that of

the field winding of the machine. To comply with this recommendation requires the selection of a field discharge breaker that has an adequate "maximum interrupting voltage rating."

Note for Synchronous Motors: Synchronous motors require a resistor across the field winding during starting to limit induced voltages in the field circuit and to obtain specific starting and pull-in torque characteristics. The resistor is usually selected by the motor designer and often ranges from 5 to 20 times the resistance of the motor field winding. In some instances, the same resistor may also be used for discharge duty if its resistance does not exceed either value calculated from equations 1 and 2. To reduce the value of resistance for discharge duty, an auxiliary contactor shorting scheme may be used to short circuit a portion of the resistor for discharge duty after the motor has started.

Table L: "Maximum Probable" Ratios of Induced Field Currents of Synchronous Machines and Dc Exciters

Type Machine	K_c Max. Ratio of the Crest Value of Induced Current to the Max. Continuous Field Current ^③	K_{dc} Max. Ratio of the Dc Component of Induced Current to the Max. Continuous Field Current ^③
Conventional 3600 rpm turbo-generators	5.5	4
"Inner-cooled" or similar turbine-generators	3 to 4 ^④	2.3 to 3 ^④
4-pole turbo and salient-pole generators	3.5	3
Dc exciters for synchronous machines	1.3	1.3

① Self-starting synchronous condensers are started as induction motors and either a main-field or an exciter-field breaker may be used.

② The "recommended transient crest voltage" is based on the field circuit insulation and may be obtained from the machine manufacturer Table M.

③ Measured at 0.1 second after the inception of a fault in the ac circuit of the synchronous machine.

④ Range to show variations for machines made by different manufacturers; the lower values apply to Westinghouse machines.

Type DB Air Circuit Breakers

For Applications up to 600 Volts Ac

Table M: Recommended Permissible Transient Crest Voltages Based on Machine Field Circuit Insulation

Exciter Nameplate Rated Voltage	Westinghouse Standard Manufacturing 60-cycle Test Voltage		Recommended Permissible Transient Crest Voltage
	Rms	Crest	
125	2500	3540	2100
250	2500	3540	2100
375	3750	5300	2470
500	5000	7070	2830

These values were selected on the basis that they would not cause undue risk of failure of a field which has deteriorated in

insulation strength but which is capable of continued safe operation at normal operating voltages.

Selection of Field Discharge Breakers

The circuit breaker duty under normal conditions and also during fault conditions must be considered in the selection of the breaker. Attention must also be given to

service conditions such as ambient temperature, vibration and contaminated atmospheres. The ratings of type DBF field discharge breakers are listed in table N.

Table N: Ratings of Type DBF Field Discharge Breakers

	Type Breaker		
	DBF-6	DBF-16	DBF-40
Rated continuous voltage, (volts, dc)	375	375	500
Rated short-time voltage, (volts, dc)	525	525	700
High potential test voltage rms, 60 cps for 1-minute (volts)	3750	3750	5000
Main Contacts			
Rated continuous current, (amperes, dc)	600	1600	4000
Maximum circuit inductance (millihenries)	1.5	.9	.4
Rated interrupting current at rated short time voltage and with max. inductance (amperes, dc)	6000	16000	40000
Rated maximum interrupting voltage (volts, dc)	1500	2150	2700
Rated interrupting current at rated maximum interrupting voltage and with max. inductance (amperes, dc)	3000	8000	15000
Discharge Contact			
Rated closing current (peak amperes)	3300	8800	16000
Rated 15-second short time current (amperes dc)	1200	3200
Rated ½-second short time current (amperes, dc)	2700	7200	14000
Rated interrupting current at rated continuous voltage - (amperes dc)	600	1600	4000

1. Exciter nameplate rated voltage: The rated continuous voltage of the field discharge breaker should equal or exceed the nominal field circuit voltage. The common nominal field circuit voltages are 125, 250, 375 and 500 volts dc.

2. Excitation ceiling voltage: There are a number of conditions that can cause excitation ceiling voltage to exist for short periods of time. Ceiling voltages are generally less than 140% of the exciter rated voltage at rated speed and generally exist for only a few seconds. The rated short-time voltage of the field discharge breaker should equal or exceed the excitation ceiling voltage.

3. Maximum continuous field current: The rated continuous current of the field discharge breaker main contacts should equal or exceed the maximum continuous field current of the machine. Ambient temperature and unusual service conditions should be considered in their effect on the current carrying capability of the breaker.

4. Interrupting current duty due to short circuits in the field circuit: The rated interrupting current of the main contacts (at rated short-time voltage) should equal or exceed the maximum short-circuit current from the excitation source (while at ceiling voltage). In a coordinated unit excitation system, the excitation source ratings are

matched to the machine excitation requirements, and the maximum short-circuit current will seldom exceed 10 times the source rated current^①. The total inductance of the excitation source circuit to the point of fault should not exceed the inductance on which the rated interrupting current is based.

5. Interrupting induced field current duty during faults in the armature circuit of the machine: Faults in the armature circuit of a machine can cause relatively high induced transient field currents. A typical oscillogram of induced transient current in the field of a 3600 rpm turbine generator for a 3-phase short-circuit at its terminals is shown in figure 14. The interrupting current duty on the main contacts is the sum of the dc component of induced field current at the instant of parting plus the current taken by the discharge resistor when the discharge contact closes before the main contacts part. The interrupting current duty may be calculated from equation 3 where the terms used are previously defined.

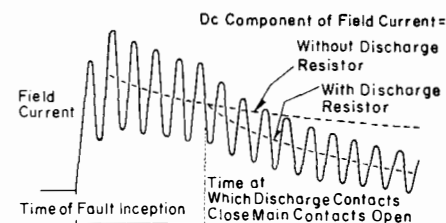

Figure 14. Typical induced transient current in the field of a 3600 rpm turbine generator for a 3 phase short-circuit at its terminals

$$\text{Equation 3. Interrupting Current Duty} = K_{dc} \times I_f + E/R_d$$

The rated interrupting current of the field breaker main contacts at rated maximum interrupting voltage should equal or exceed the interrupting current duty at the dc recovery voltage of the circuit. For synchronous machines the interrupting current duty for an ac circuit fault will seldom exceed 5 times the maximum continuous field current of the machine. The total inductance of the excitation source (including the leads to the field breaker) plus the inductance of the discharge resistor should not exceed the inductance on which the rated interrupting current is based.^②

^① Attention must be given to machine fields connected to high capacity excitation buses where the available dc fault current may be greater than that obtained from a coordinated unit excitation system.

^② Series overcurrent tripping devices are omitted from field breakers as they respond to overcurrents in the field circuit due to disturbances on the ac system of the machine, which could cause undesirable tripping of the breaker.

Westinghouse



6. Dc recovery voltage duty during a fault in the armature circuit of the machine: The dc recovery voltage is the dc voltage that appears across the open contacts of a breaker at the instant immediately following interruption of current by those contacts. Opening the field breaker immediately following a fault in the armature circuit of a machine can result in high circuit recovery voltages due to the relatively high voltage drop across the discharge resistor. This voltage is determined by the field circuit parameters and may be calculated from equation 4 where the terms used are previously defined.

Equation 4. Dc Recovery Voltage Duty = $(K_{dc} \times I_f) R_d + E$

The rated maximum interrupting voltage of the field breaker main contacts should equal or exceed the dc recovery voltage duty of the circuit. The recovery voltage duty may be reduced by decreasing the discharge resistance (R_d); however, the resistance should not be made less than that of the field winding of the machine to avoid excessive transient armature current.

7. Discharge contact duty and ratings: The current and voltage duties on the discharge contact of field breakers generally are low and do not influence the selection of the field breaker.

Simplified Application Tables for the Selection of Field Discharge Breakers and Discharge Resistors

Table O and P have been prepared to simplify and coordinate the application of field discharge breaker and discharge resistors. The information needed to select the proper field breaker and discharge resistor is the nominal field voltage, the maximum continuous field current and the type synchronous machine.

Table O, which shows recommended field discharge breakers, is applicable under the following conditions:

- (a) for coordinated unit excitation systems
- (b) where the discharge resistor has been selected from table O.

Table P, which shows recommended values of field discharge resistance, is based on the use of field discharge breakers as listed in table O. The values are based on equations 1 and 2, page 26, and limit the crest voltages in the field circuit to values equal to or less than the recommended permissible voltages (table M), and also limit the recovery voltage duty on the breaker to values equal to or less than the maximum interrupting voltage rating of the breaker (table N).

Table O: Recommended Field Discharge Breakers^①

Exciter Nameplate Rated Voltage	Max. Cont. Field Current Amperes ^④	Main-Field Breaker and Type Synchronous Machine				Exciter-Field Breakers for Synch. Machine Exciters
		Conv. 3600 Rpm Turbo-Gen.	"Inner Cooled" Turbo-Gen.	Salient Pole Gen. or Synch. Condenser	Synch. Motors ^③	
125	0-600	DBF-6	②	DBF-6	DBF-6	DBF-6 ②
	601-1600	DBF-16	②	DBF-16	②	
250	0-600	DBF-6	②	DBF-6	DBF-6	DBF-6 ② ②
	601-1600	DBF-16	②	DBF-16	②	
	1601-4000	②	DBF-40	②	②	
375	0-600	DBF-16	②	DBF-16	②	DBF-6 ② ②
	601-1600	DBF-16	②	DBF-16	②	
	1601-4000	②	DBF-40	②	②	
500	0-4000	②	DBF-40	②	②	②

- ① Table may be used only for coordinated unit excitation systems where the field discharge resistance has been selected from table P. If the field discharge resistor has been selected by some means other than table P, the adequacy of the field discharge breaker should be examined by use of equation 4.
- ② Field breakers for the type machine having field voltages and currents as shown are uncommon.
- ③ May require auxiliary contactor.
- ④ For hydrogen cooled machines, use the maximum continuous field current at maximum hydrogen pressure.

Table P: Recommended Values of Field Discharge Resistance Expressed as a Multiple of the Ratio

Nominal field circuit voltage
Maximum continuous field current ^①

Exciter Nameplate Rated Voltage	For the Main Field of Synchronous Machines				For the Field of An Exciter Used with Synch. Machines
	Conv. 3600 Rpm Turbo-Gen.	Inner-Cooled Turbo-Gen.	Salient Pole Gen. or Synch. Cond.	Synch. Motor	
125	2.8	...	3.7	3.7	8.5
250	1.3	2.8	1.7	1.7	3.9
375	1.2	2.2	1.6	...	2.3
500	...	1.9

- ① Table may be used only for coordinated unit excitation systems where the field discharge breaker has been selected from table O. If a field discharge breaker other than shown in table O is used, the field discharge resistance should be selected as outlined on page 26, using equations 1 and 2.

Type DB Air Circuit Breakers

For Applications up to 600 Volts Ac

Shunt Capacitor Switching

The major factors to be considered in the application of low voltage breakers for capacitor switching are as follows:

1. Fault current contribution from energized capacitor banks.
2. Inrush current to switched isolated banks or parallel banks.
3. Transient overvoltage incident to switching with or without restrikes.
4. Continuous current requirements.
5. Overcurrent tripping characteristics.

Fault Current Contribution From Energized Capacitor Banks

The short-circuit current contributed by an energized capacitor bank is usually of short duration and has a natural frequency greater than the fundamental frequency of the system. The maximum short-circuit current contributed by an energized capacitor bank flows when the fault occurs at a voltage crest. The capacitor bank contribution may be added to the system short-circuit current of fundamental frequency to determine the total interrupting duty of the circuit breakers; however, the capacitor contribution is generally of such short duration that it is neglected in selecting the breaker.

Inrush Current to Switched Isolated Banks or Parallel Banks

Inrush currents during switching of capacitor banks should be considered in their effect on the ability of the breaker to close and latch against the forces developed by the inrush current. The inrush currents for isolated capacitor banks do not impose duty on the breaker in excess of its capabilities; however, parallel bank switching may require special consideration. The crest of the inrush current for parallel bank switching may be calculated from the following formula:

$$I_{\text{crest}} = 2 \sqrt{2} E_{L-N} \sqrt{\frac{C_0}{L}}$$

where E_{L-N} = normal rms, 60 cycle line to neutral voltage

C = equivalent capacitance (microfarads) of the energized bank

L = equivalent inductance (microhenries) of the circuit being switched, including the inductance of the energized bank, bus and breaker

① Based on the bank being switched fully charged.

The inrush for parallel capacitor bank switching may be reduced by spacing the parallel banks far enough apart to obtain sufficient inductance between the banks, or by reducing the kva rating of the banks.

Transient Overvoltage Incident to Switching With or Without Restrikes

High transient overvoltage during switching can occur if the breaker restrikes during opening. Experience indicates that switching of low voltage capacitor banks does not result in excessive overvoltages.

Continuous Current Requirements

The continuous current rating of the breaker should be at least 135% of the capacitor bank rated current. This is to allow for harmonic currents that may flow in addition to the current of fundamental frequency, and also to allow for operation of the capacitors at 10% above rated voltage.

Overcurrent Tripping Characteristics

Series overcurrent tripping devices are generally used on breakers for capacitor banks to provide short-circuit protection. The devices usually have long delay and instantaneous tripping characteristics. The setting of the instantaneous trip must be sufficiently high to override the inrush currents during switching. Because of the short duration of the inrush current (usually a fraction of a cycle), instantaneous trip settings of 8-10 times the breaker rating have usually proven satisfactory for switching isolated banks.

Other Applications

Lighting Transformers

Frequently on 480 and 575 volt systems, transformers will be employed to reduce the voltage to a value convenient for lighting loads. The low voltage air circuit breaker that supplies a lighting transformer should have a continuous current rating at least 125 percent of the transformer rated full-load current. The breaker should also be equipped with series overcurrent devices of the long delay and instantaneous type as shown by curve no. 405123 and curve no. 388530. The setting of the instantaneous element must be high enough to override the transformer magnetizing inrush current that flows when the transformer is energized. A pickup setting of approximately 12 times the transformer rated full-load current is usually satisfactory.

Bus Duct Protection

Bus duct is usually used in industrial distribution systems to supply a relatively large number of small loads. The inrush current of the individual loads is usually small com-

pared to the rating of the bus duct and breaker. This means that breaker protecting the bus duct can and should have a low instantaneous trip setting (or low short delay pickup setting if selective tripping is applicable), thus giving the required arcing fault protection.

Series overcurrent devices for bus duct breakers should be selected so that the pickup current of the instantaneous trip (or short delay) can be set low, but set to override the largest expected load inrush. Pickup settings as low as 5 times the trip coil rating are common.

Application of Manually Operated Circuit Breakers

Manually operated circuit breakers shall be limited to applications which do not present a safety hazard to operating personnel when standing directly in front of the circuit breaker.

1. For this reason, low voltage air circuit breakers shall have electrically operated mechanism or independent manual (spring closing) mechanism if the following conditions exist:
 - a. For dead front and individually enclosed breakers equipped with instantaneous trip devices where the interrupting requirements exceed 42000 symmetrical rms amperes.
 - b. For dead front and individually enclosed breakers equipped with instantaneous trips, where the maximum instantaneous trip setting exceed 15000 symmetrical rms amperes.
 - c. For all circuit breakers equipped with selective overcurrent trip devices where the delayed tripping requirements exceed 14000 symmetrical rms amperes (selective trip).
 - d. For all circuit breakers without direct acting overcurrent trip devices where the interrupting requirements exceed 14000 symmetrical rms amperes.

Westinghouse



Fault Calculations—Three-Phase

Tables A through D, pages 3, 4, 5 and 6 are intended mainly for the quick estimating of short-circuit currents and required breaker types. The tables are, generally, sufficiently accurate to establish the breaker interrupting requirements for breakers located near the transformer. This section is devoted to the more accurate calculation of the short-circuit currents on low voltage systems, which may be required when:

1. There is a "borderline" case and it is necessary to verify the adequacy of the interrupting rating of a particular breaker.
2. The accurate short-circuit current at a remote point in the system is required, where the fault current is limited by cables or buses or where the system X/R ratio to the point of fault is more than 6.6.
3. Cases exist that are not covered by the tables, such as fault currents from low voltage generators or the accurate calculation of fault currents from large motors.

Associated with a short circuit or a fault on an ac system is the flow of abnormally high currents that may be many times the normal load current of the circuit. The magnitude of the short-circuit current is dependent upon basic factors that are common to any electrical circuit; namely, the voltage sources and the circuit impedances.

The power source(s) that normally feed the system load will, in general, contribute the major portion of the total short-circuit current. However, all rotating machines, including induction and synchronous motors, that are connected to the system at the time of the fault will also contribute short-circuit current and therefore, should be included in the calculation.

The sudden application of a short circuit on an ac system results in a dc component in addition to the ac component mentioned above. When added, they result in an offset or asymmetrical current. See figure 15.

Figure 15: Fully Asymmetrical Short-Circuit Current

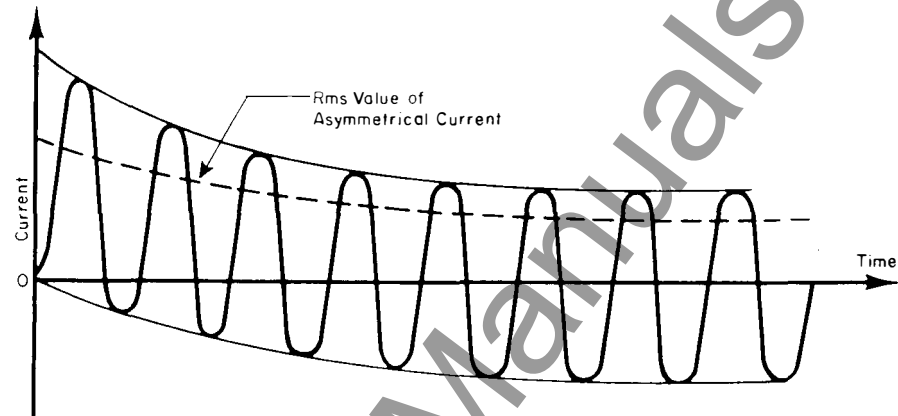

Although the dc component decays rapidly, it is generally significant during the first few cycles (time on 60-cycle basis) after the inception of the fault. The existence of the dc component increases the interrupting duty on the circuit breakers.

System of Units and Base Quantities

The base current and percent values must all be referred to a common base kva. When the base voltage and kva have been selected, the following equations should be used:

1. Base current, $I_B = \frac{\text{base kva} \times 1000}{\sqrt{3} \times \text{base line-line voltage}}$
2. The value of any resistance, reactance or impedance in ohms can be converted to percent by:
Percent value on base kva = $\frac{\text{Base kva} \times \text{ohms} \times 10^5}{(\text{Base line-line voltage})^2}$
3. To change a percent value from one base kva to a new base kva:
 $\left(\frac{\text{Percent value}}{\text{on new base kva}} \right) = \left(\frac{\text{Percent value}}{\text{on old base kva}} \right) \times \frac{\text{New base kva}}{\text{Old base kva}}$
4. To change a percent value from one base voltage to a new base voltage:
 $\left(\frac{\text{Percent value on}}{\text{new base voltage}} \right) = \left(\frac{\text{Percent value on}}{\text{old base voltage}} \right) \times \left(\frac{\text{Old base voltage}}{\text{New base voltage}} \right)^2$

Type DB Air Circuit Breakers

For Applications up to 600 Volts Ac

Type of Faults

It is logical to base the selection of low voltage breakers on the most severe fault conditions that the system can produce. This is represented by a 3-phase, bolted short circuit^①. Fault or arc impedance is not considered in the calculations as the current limiting effects are unpredictable.

Time of Maximum Fault Current

The short-circuit calculations should be based on the ½-cycle current value using subtransient current and impedance values. Tests indicate that low voltage breakers of the type DB are capable of beginning current interruption between ½ to 1-cycle after the fault occurs; hence, the interrupting duty on low voltage air circuit breakers is based on the current flowing ½-cycle after the inception of the fault.

Impedances

The impedance, Z, of a circuit made up of resistance R, and reactance X, is given by:

$$Z = \sqrt{R^2 + X^2} = X \sqrt{1 + \frac{1}{(X/R)^2}}$$

The impedance of breaker series trip coils is generally negligible but may be included if desired. In determining the interrupting capacity of a breaker for a particular point in the system, the impedance of that breaker trip coil should be omitted in the calculations. (The reason for this is that the breakers are rated and tested on the basis of the short-circuit current that flows without the breaker in the test circuit.) Trip coil impedances of other breakers in the system may be included in the calculations.

The following tables give typical impedance data for apparatus commonly used on low voltage systems. This data is approximate and should only be used when exact data is not available.

① A possible exception to this would be a phase to neutral short-circuit on a delta wye grounded neutral transformer with little or no connected motor load. The zero sequence impedance from the fault to the transformer might be less than the total positive sequence impedance. This case is very unusual because motor feedback almost invariably makes the effective positive sequence impedance less than the zero sequence impedance.

Table Q: Approximate Values of Resistance, Reactance, Impedance and X/R Ratios of 600 Volts or Less, 60 Cycles, 3-Phase, Westinghouse Standard Transformers

(Values in percent on rated kva as base)

(Primary Voltage – 15 kv or less)

Kva	Percent							
	% Resistance		% Reactance		% Impedance		X/R Ratio	
	DT3	ASL	DT3	ASL	DT3	ASL	DT3	ASL
Liquid Filled, Self-Cooled								
150		1.37		3.75		4.0		2.74
225		1.57		4.21		4.5		2.68
300		1.48		4.77		5.0		3.22
500		1.30		4.83		5.0		3.71
750		1.28		5.60		5.75		4.37
1000		1.21		5.62		5.75		4.64
1500		1.06		5.64		5.75		5.32
2000		1.00		5.66		5.75		5.66
2500		.97		5.67		5.75		5.85
Dry Type, Ventilated								
150	2.5	1.84	1.26	4.65	2.8	5.0	.504	2.53
225	2.16	2.04	4.28	4.57	4.8	5.0	1.98	2.24
300	2.01	2.40	5.64	4.39	6.0	5.0	2.8	1.83
500	1.65	2.23	5.77	4.5	6.0	5.0	3.49	2.02
750	1.54	1.94	5.8	5.41	6.0	5.75	3.76	2.79
1000		1.70		5.49		5.75		3.23
1500		1.63		5.51		5.75		3.42
2000		1.63		5.51		5.75		3.42
2500		1.42		5.57		5.75		3.93
Dry Type, Sealed								
300		1.86		4.64		5.0		2.49
500		1.58		4.74		5.0		3.0
750		1.32		5.59		5.75		4.23
1000		1.08		5.64		5.75		5.21
1500		1.05		5.65		5.75		5.38
2000		.945		5.67		5.75		6.01
2500		.855		6.18		6.25		7.24

Table R: Average Values of Subtransient Reactance of 600 Volts or Less, 60-Cycle Rotating Apparatus

(Values in percent on rated kva and voltage as base)

	Range	Mean
Small turbine generators 625-2500 kva.....	7-14	10%
Salient-pole generators (with dampers).....	13-35	20%
Synchronous motors.....	13-35	20% ^②
Induction motors.....	12-30	20% ^②

② For motors, the rated kva may be taken as:
 $\sqrt{3} \times (\text{rated line-to-line voltage}) \times (\text{full load amperes of motor})$

Table S: Reactance and Resistance of 3-Conductor Stranded Copper Cables Ohms per 100 Feet at 60 Cycles

Size of Conductor AWG or Circular Mills	Resistance per Phase ^③ at 25 Degrees C	Reactance per Phase ^④ (up to 1-kv Insulation)
6	.0420	.0035
4	.0265	.0033
2	.0166	.0031
0	.0106	.0029
0000	.0053	.0025
250000	.0045	.0024
350000	.0032	.0024
500000	.0023	.0023
750000	.0016	.0023

③ The resistance values may be used for any frequencies, 60 cycles or below.

④ The reactance at any frequency is f/60 times the values above. The resistance and reactance values apply for cables in non-magnetic duct. For magnetic duct, the same resistance values may be used and approximate reactance values may be obtained by increasing the values above by a factor 1.15.

Westinghouse



Reactors

The X/R ratios for type MSP current-limiting reactors range from approximately 6 to 24. The low value corresponds to low-current,

low-impedance designs, and the high value to high-current and high-impedance designs.

Table T: Single-Phase Reactance and Ac Resistance Ohms per 100 Feet of Stranded Copper Single-Conductor 60 Cycles^①

Size of Conductor AWG or Circular Mils	Resistance in Ohms Per 100 Feet of Single Conductor at 25 Degree C (77 Degree F) 60 Cycles	Reactance in Ohms Per 100 Feet of Each Conductor of a Single-Phase or a Symmetrical Three-Phase Circuit										
		② Symmetrical Spacing (D) of Conductors in Inches										
		3	4	5	6	7	8	9	10	11	12	15
6	0.0410	0.0088	0.0094	0.0099	0.0103	0.0107	0.0110	0.0113	0.0115	0.0117	0.0119	0.0124
4	0.0259	0.0082	0.0089	0.0094	0.0098	0.0102	0.0105	0.0108	0.0110	0.0112	0.0114	0.0119
2	0.0162	0.0077	0.0084	0.0089	0.0093	0.0097	0.0100	0.0103	0.0105	0.0107	0.0109	0.0114
1	0.0129	0.0074	0.0081	0.0086	0.0090	0.0094	0.0097	0.0099	0.0102	0.0104	0.0106	0.0111
0	0.0102	0.0071	0.0078	0.0083	0.0087	0.0091	0.0094	0.0096	0.0099	0.0101	0.0103	0.0108
00	0.0081	0.0069	0.0076	0.0081	0.0085	0.0089	0.0092	0.0094	0.0097	0.0099	0.0101	0.0106
000	0.0064	0.0066	0.0073	0.0078	0.0082	0.0086	0.0089	0.0091	0.0094	0.0096	0.0099	0.0104
0000	0.0051	0.0063	0.0070	0.0075	0.0079	0.0083	0.0086	0.0088	0.0091	0.0093	0.0095	0.0100
250	0.0043	0.0062	0.0069	0.0074	0.0078	0.0082	0.0085	0.0087	0.0090	0.0092	0.0094	0.0099
300	0.0036	0.0060	0.0067	0.0072	0.0076	0.0080	0.0083	0.0085	0.0088	0.0090	0.0092	0.0097
400	0.0027	0.0055	0.0062	0.0067	0.0071	0.0075	0.0078	0.0080	0.0083	0.0085	0.0087	0.0092
500	0.0022	0.0052	0.0059	0.0064	0.0068	0.0072	0.0075	0.0077	0.0080	0.0082	0.0084	0.0089
750	0.0014	0.0047	0.0054	0.0059	0.0063	0.0067	0.0070	0.0072	0.0075	0.0077	0.0079	0.0084
1000	0.0011	0.0044	0.0051	0.0056	0.0060	0.0064	0.0067	0.0069	0.0072	0.0074	0.0076	0.0081

① The reactance at any frequency, f, is f/60 times the reactance at 60 cycles.

② For any 3-phase arrangement of conductors, $D = \sqrt{ABC}$, where A, B, and C are the spacings between conductors. This resolves itself into $D = A, B, \text{ or } C$ for symmetrical triangular spacing, and into $D = 1.26A$ (or B) for regular flat spacing.

for any other size conductor, of diameter d, the 60-cycle reactance in ohms per 100 ft., at symmetrical spacing D, may be computed from the formula,

$$X = 0.000575 + 0.00529 \log_{10} \left(\frac{2D-d}{d} \right)$$

Table TA: Resistance and Reactance of Type DB Circuit Breakers^①

Breaker	Trip Coil	R	X	Breaker	Trip Coil	R	X
DB-25	100	540	1450	DB-50	200-225	324	3140
	125	420	1070		250	250	2300
	150	310	740		300	170	1600
	200	200	470		350-400	115	1000
	225-300	140	270		500-600	90	580
	350-500	90	120		800-1000	50	260
	600	60	30		1200-1600	40	60
DB-75	2000-3000	14	85	DB-100	4000	11	75

① Resistance and Reactance values listed are in micro ohms and are applicable to 60 cycles per second currents of short circuit magnitude. For 50 cycle per second currents, multiply Reactance values by 5/6, and use Resistance values without modification.

Type DB Air Circuit Breakers

For Applications up to 600 Volts Ac

Table U: Bus Duct Impedances Average Values – Ohms Per Phase Per 100 Feet Plug-In Bus Duct

Ampere Rating	225	400	600	800	1000	1250	1500
Number and Size of Bars	1 (1/4 x 1/4)	1 (1/4 x 1 1/2)	1 (1/4 x 2)	1 (1/4 x 3)	1 (1/4 x 4)	1 (1/4 x 5)	1 (1/4 x 6)
Resistance	0.009	0.0029	0.0024	0.0017	0.0012	0.0009	0.0008
Reactance (60-Cycle)	0.007	0.006	0.0053	0.0042	0.0034	0.0030	0.0027
Low-Impedance Bus Duct (Ventilated)							
Ampere Rating	600	800	1000	1350	1600	2000	2500
Number and Size of Bars	2 (1/4 x 1)	2 (1/4 x 1 1/2)	2 (1/4 x 2)	2 (1/4 x 2 1/2)	2 (1/4 x 3)	2 (1/4 x 4)	2 (1/4 x 5)
Resistance	0.0020	0.0013	0.0010	0.00088	0.0006	0.0005	0.0004
Reactance (60-Cycle)	0.0023	0.0016	0.0013	0.00095	0.00090	0.00065	0.00054
Ampere Rating	3000	4000	5000				
Number and Size of Bars	2 (1/4 x 6)	4 (1/4 x 4)	4 (1/4 x 5)				
Resistance	0.00033	0.00027	0.00022				
Reactance (60-Cycle)	0.00046	0.00036	0.00028				

The reactance of any frequency, f, is f/60 times the values above.

Bus Bar Reactances @ 60 Cycles

① For estimating purposes, the values of resistances may be assumed the same as those given for bus duct for the same number and size of bars per phase.

Figure 16

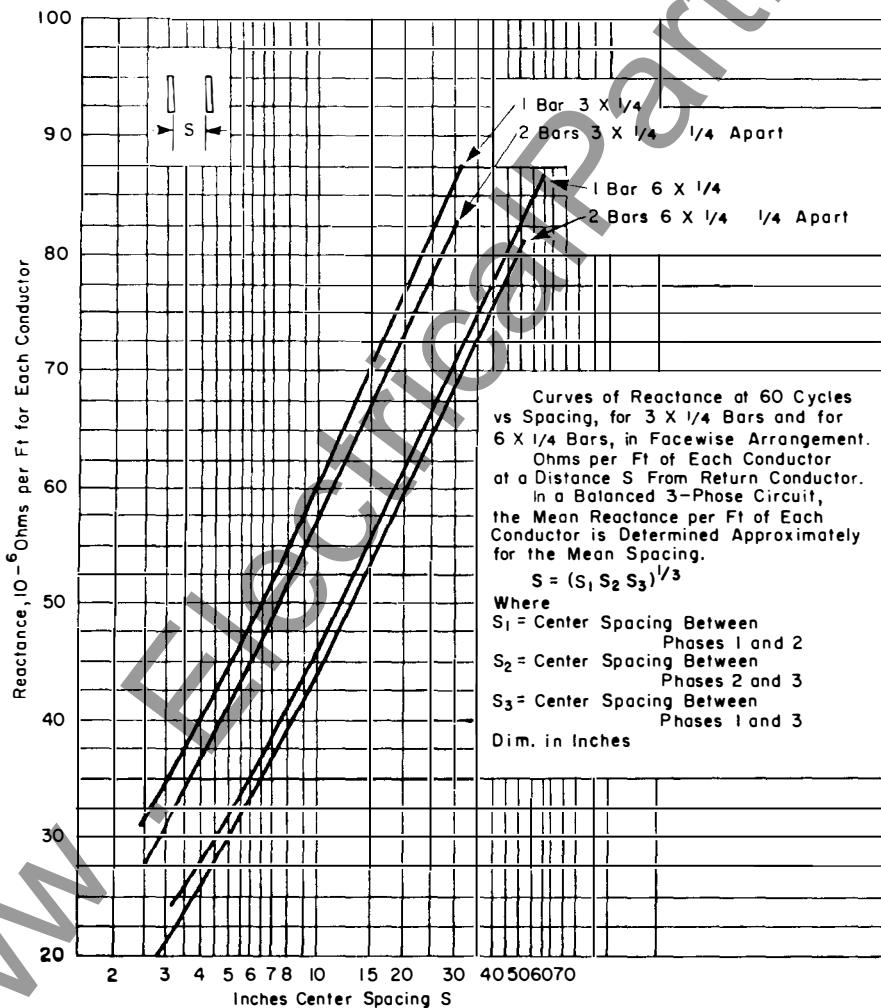

Westinghouse



Figure 17

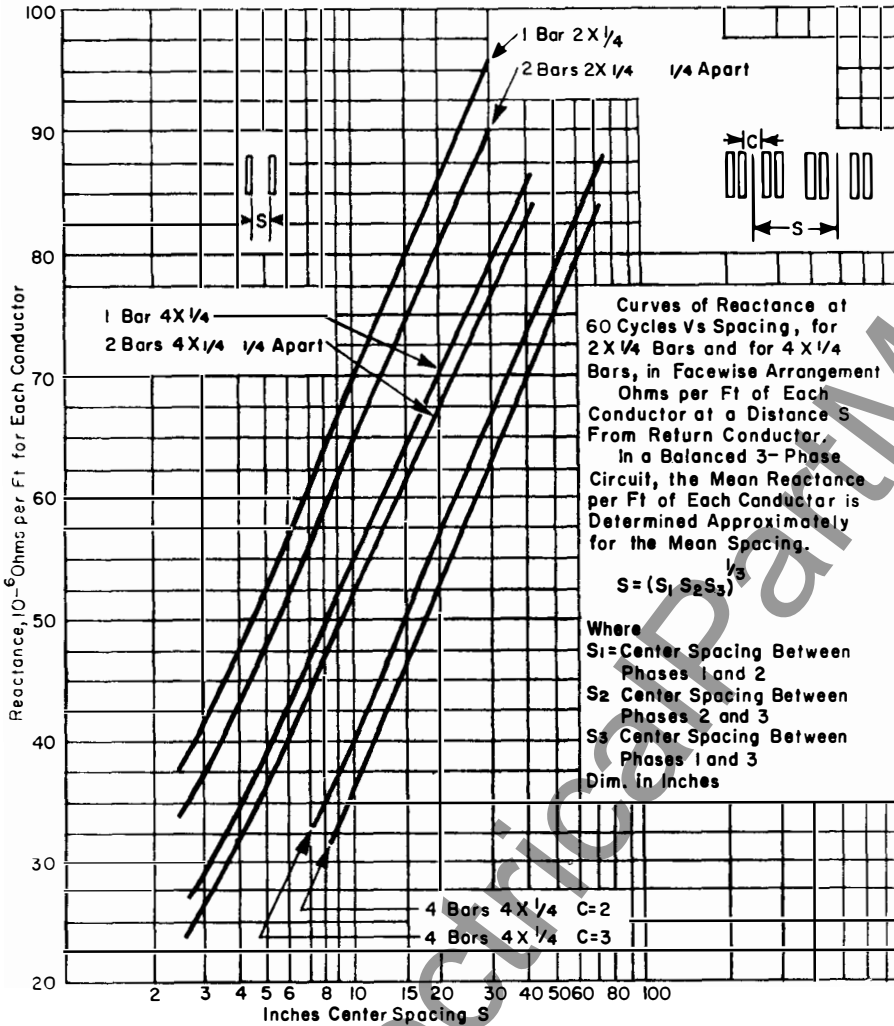

Asymmetry Due to the Dc Component

Any sudden change in an electrical circuit is initially opposed by the inductance of the circuit. In other words, the current cannot change instantaneously. However, at the instant the fault occurs an ac component of current must flow as determined by ac voltage and impedance of the system. The net result is that:

1. An ac component of short-circuit current flows as determined by the ac voltage and impedance of the system. This is referred to as the symmetrical short-circuit current. See figure 18.
2. The dc component flows to satisfy the inductance effect; that is, that the current cannot change instantaneously. This dc

component is initially equal in magnitude and of opposite instantaneous polarity to the ac component of fault current. Note that the addition of the ac and dc components at time equal zero gives zero current, hence, satisfying the inductance effect.

As there is no dc driving voltage maintained after the fault occurs, the dc component decays to zero. The rate at which it decays is a function of the X/R ratio of the system to the point of fault. X is the reactance and R is the resistance.

3. The resultant short-circuit current is the sum of the ac and dc components. Note that it can be offset due to the dc component and, hence, is referred to as the asymmetrical short-circuit current. The rms

value of the asymmetrical current can be calculated from the following formula:

$$I_{\text{asym. rms}} = \sqrt{(I_{\text{sym}})^2 + (I_{\text{d-c}})^2}$$

I_{sym} = rms value of the symmetrical current (a-c component)

I_{d-c} = value of the d-c component

Figure 18: Typical Curves of Ac and Dc Components Resulting in a Fully Asymmetrical Short-Circuit Current for One Phase of a 3-Phase System Zero Current Prior Fault

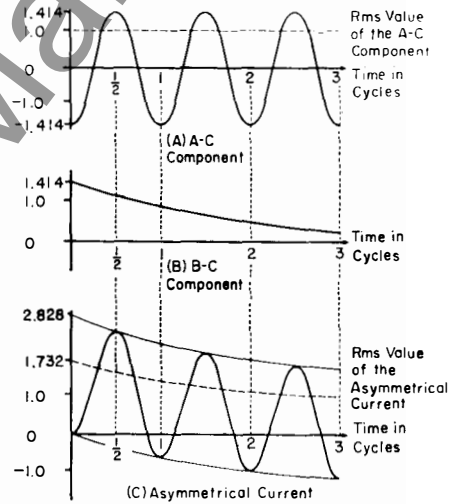

The initial magnitude of the dc component will depend on the point of the voltage wave at which the short circuit occurs and the presence of load current. The maximum rms value of asymmetrical current can be as high as 1.73 times the symmetrical current (rms) at the instant the fault occurs; however, due to the decay of the dc component, the rms value of the asymmetrical current is considerably reduced at the 1/2-cycle time.

On 3-phase systems, the dc component, and hence the asymmetry, is not the same on all phases. For instance, when the dc component is a maximum on one phase, it is only half that value on the other two phases.

The interrupting ratings of low voltage air circuit breakers are expressed in rms symmetrical amperes at the rated voltage. The symmetrical current of the rating is defined as an ac component of the total short circuit current at the instant 1/2 cycle after the short circuit occurs. According to NEMA standards the breaker however shall be able to

Ⓞ The rms value of the asymmetrical current for the phase that has maximum asymmetry may actually exceed even 1.73 times the symmetrical component depending on load conditions prior to the fault in the particular circuit under consideration.

Type DB Air Circuit Breakers

For Applications up to 600 Volts Ac

interrupt the rms symmetrical current as well as every degree of asymmetry up to an X/R ratio of not less than 6.6. For a 3-phase circuit, the average rms asymmetrical current is defined as the average of the rms values of the asymmetrical currents (ac plus dc components) in three phases, measured at the instant $\frac{1}{2}$ cycle after the short circuit occurs. This value will be referred to as the average rms asymmetrical current (in other literature sometimes referred to as the 3-phase average total rms current) and should be used in selecting the required breaker rating wherever the X/R ratio of the circuit is more than 6.6. In these cases, the asymmetrical rating of the breaker (they are given in table A on page 3 along with the symmetrical ratings) has to be larger than the average rms asymmetrical current available at the point of application of the breaker.

To calculate the average rms asymmetrical current, the ac component or symmetrical current can be multiplied by an average asymmetry factor, F, that:

1. Takes into account the value of the dc component at the $\frac{1}{2}$ -cycle time.
2. Averages the rms values of the asymmetrical currents in the three phases. This average asymmetry factor depends on the X/R ratio of the total impedance to the point of fault and may be taken directly from figure 19, hence:

$$I_{\text{avg rms asym}} = F \times I_{\text{sym}}$$

As an example, if the calculated rms symmetrical short-circuit current is 21900 amperes, and the X/R ratio of the circuit is 20, then from figure 19 the average asymmetry factor is 1.31 and the average rms asymmetrical current would be $21900 \times 1.31 = 28700$ amperes. Therefore, the required asymmetrical interrupting rating of a low voltage breaker at that point in the system has to be higher than 28700 rms asymmetrical amperes.

When sufficient data is not available to calculate the actual X/R ratio for a particular breaker application, and there are indications that the X/R ratio is more than 6.6 (large sealed dry type transformers) it is recommended that the average asymmetry factor of 1.25 corresponding to X/R ratio of 11.76 should be used in calculating the available rms asymmetrical current.

The use and derivation of average rms asymmetry factors is based on one phase being, initially, fully asymmetrical. This means that the short-circuit current that the

particular pole of the breaker must interrupt is greater than the average rms asymmetrical value. Therefore, it should be clearly understood that although low voltage air circuit breakers are rated in terms of rms symmetrical current, any one of the poles in the breaker must be capable of interrupting a current that was initially fully asymmetrical. The rms value of this current through that particular pole the instant $\frac{1}{2}$ cycle after the fault occurs, is obviously higher than the rms value of its ac component. It is also higher than the average rms asymmetrical. Corresponding to the X/R ratio of 6.6 is an average asymmetry factor of 1.17 and a maximum asymmetry factor of 1.33 for the one phase that was initially fully asymmetrical.

Figure 19: Average and Maximum Asymmetry Factors

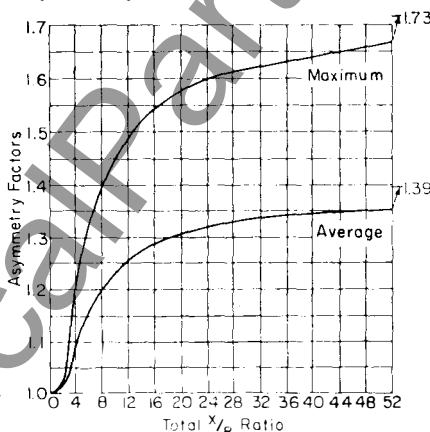

Sources of Short-Circuit Current

The sources of short-circuit current on low voltage systems may be any combination of supply transformers or generators, including feedback from motors on the system at the time of the fault.

1. Supply Transformers: This is by far the most common form of power supply for low voltage systems. The transformer impedance is generally the major factor in determining the short-circuit current.

The voltage impressed on the primary of the transformer during a low voltage fault will be less than the rated value because of the impedance of the high voltage system. Hence, the magnitude of the low voltage, short-circuit current will be less than the value based on the transformer impedance alone. The minimum, equivalent subtransient impedance of the high voltage system, to which the transformer primary is con-

nected, should be included in the calculations. The capacity of power systems is continually growing and for this reason it is good practice to calculate the minimum equivalent subtransient impedance based on the projected future, available short circuit kva of the primary system, or on the interrupting rating of the transformer primary breaker or fuse if more exact data is not available.

The symmetrical value of fault current flowing through one transformer to a bolted, 3-phase short circuit at its low voltage terminals is:

$$I_{\text{sym}} = \frac{I_b}{Z_p + Z_t} \times 100$$

where, I_{sym} = rms value of symmetrical 3-phase short-circuit current in amperes.

I_b = Base current on the low voltage side in amperes (note, that it is usually convenient to select the transformer self-cooled rated kva and line-to-line low voltage as the base units since, when this is done, base current becomes the transformer rated current).

Z_t = Transformer impedance in percent.

Z_p = Minimum equivalent subtransient impedance of the primary system which is:

$$\%Z_p = \frac{\text{base kva}}{\text{primary available S-C kva}} \times 100$$

Note: The base current and impedances must be on the same kva base. Also, Z_p and Z_t must be added vectorially; that is:

$$Z_p + Z_t = \sqrt{(r_p + r_t)^2 + (x_p + x_t)^2}$$

where r and x are the resistance and reactance, respectively.

The total resistance ($r_p + r_t$) and total reactance ($x_p + x_t$) should be used to determine the proper average asymmetry factor F. The average rms value of asymmetrical short-circuit current is:

$$I_{\text{avg rms asym}} = F \times I_{\text{sym}}$$

where F may be determined from figure 19 page 35.

① For transformers in parallel, the impedance of each transformer should be converted to a common kva base. The impedances should then be paralleled (vectorially) and the resultant equivalent impedance should be used for Z, in the formula.

Westinghouse



2. Low-voltage generators: The initial value of short-circuit current is dependent upon the machine subtransient reactance. This initially high current decays to a considerably lower, sustained value that is contingent upon the machine synchronous reactance and the characteristics of the generator excitation system. However, at 1/2 cycle after the fault, the symmetrical value of fault current for a bolted 3-phase short-circuit can be calculated by using the machine subtransient reactance as shown below.

$$I_{sym} = \frac{I_B}{X_d'' + Z_a} \times 100$$

I_{sym} = rms value of symmetrical short-circuit current in amperes.

I_B = Generator rated current in amperes, the generator rated kva and voltage are the base units.

X_d'' = Generator subtransient reactance in percent.

Z_a = Generator lead impedance in percent.

The X/R ratio of generators is usually high@ hence, the typical, average asymmetry factor of 1.17 may not be applicable. Cables and cable connections from the generator to the switchgear can considerably reduce the total X/R ratio and, therefore, should be included in the calculations.

3. Motor Feedback: During a short circuit, both induction and synchronous motors that were connected to the system when the fault occurred will act as equivalent generators and feedback current to the point of fault.

General Case: In many cases, actual data on the motors will not be readily available. Moreover, it is not possible to predict the exact percentage of the total motor load that will be connected to a system when a fault occurs. Therefore, in the general case and in the absence of more exact data, the following procedure should be used to calculate motor feedback.

1. For 240- to 600-volt systems – assume 100 percent motor load.

For 120/208-volt systems – assume 50 percent motor load.

② The X/R ratio for determining the average asymmetry factor is the ratio X_2/r_a where X_2 is the negative sequence reactance of the generator and r_a is the d-c resistance of the armature (phase-to-neutral value). The values of X_2/r_a depend on the machine design and rating and may range from 10-40 for the type of machines usually encountered on low-voltage systems. External reactance and resistance should be added to X_2 and r_a , respectively.

2. The symmetrical value of short-circuit current contributed by the motors will be approximately four times the load current drawn by the assumed motor load. This approximation is representative of the average low voltage industrial system composed predominantly of induction motors but with some synchronous motors. It also takes into account the rapid decay of fault current from the induction motors and the average effects of the motor leads.

3. The average rms value of asymmetrical current contributed by the motors may be calculated as 4.7 times the load current drawn by the assumed motor load. This is equivalent to using an approximate average asymmetry factor of 1.17 for motor feedback.

General Procedure for Fault Calculations

Step 1. Select a base kva and calculate all impedances accordingly.

Step 2. Determine the base current on the selected base kva.

Step 3. Calculate the symmetrical short-circuit current contributions to the point of fault from all sources including motor feedback.

Step 4. Determine the X/R ratios from each source. If none of them is more than 6.6, as would be the case with most of the transformer installations, take the sum of symmetrical current contributions from all sources. In this case (X/R less than 6.6) select breakers by their symmetrical ratings.

Step 5. If some of X/R ratios are more than 6.6, determine the asymmetry factors based on the total X/R ratios from each source to be applied to each symmetrical current contribution.

Step 6. Calculate the average rms asymmetrical current contribution from all sources (using the average asymmetry factors in step 5) and take their sum at the point of fault. Select the breakers by their asymmetrical ratings.

Fault Calculation Example: With modern Westinghouse transformers of standard design, it is not often required that the asymmetrical fault current be calculated since the X/R ratio is nearly always less than 6.6 (refer to Table Q on page 31). Modern transformers of special design, and many older transformers, may have higher X/R ratios and hence require breaker application based on asymmetrical ratings. The fault calculation example which follows shows the procedure for determining asymmetrical fault currents in a system.

Figure 20: System Diagram for Fault Calculation

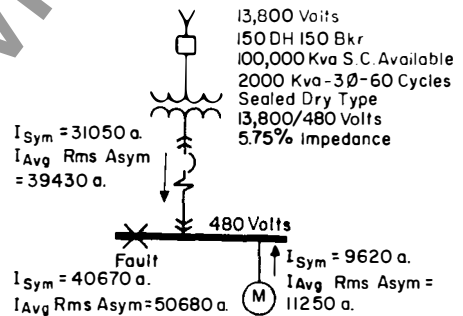

Equivalent Source Representing Feedback From an Assumed 100% Motor Load: 2000 Kva

Step 1. Select a 2000-kva base and calculate impedances accordingly:

a Transformer Circuit	%R	%X	%Z	Comments
Primary System Transformer	Neglect 0.45	2.00 5.70	2.00 5.75	① ②
$Z_p + Z_t$	0.45	7.70	7.75	$Z = \sqrt{R^2 + X^2}$

Step 2. Base current,
Base kva x 1000

$$I_B = \frac{\text{Base kva} \times 1000}{\sqrt{3} \times (\text{normal line-line voltage})}$$

$$= \frac{2000 \times 1000}{\sqrt{3} \times (480)}$$

$$= 2406 \text{ amperes}$$

① The resistance of the primary system was assumed negligible compared to the reactance hence, the magnitude of the reactance is equal to the impedance for all practical purposes.

$$\%Z = \frac{\text{base kva} \times 100}{\text{S-C kva}} = \frac{2000}{100000} \times 100 = 2.0\%$$

② Refer to table Q, page 31, for transformer data. The impedance of the connection between the transformer and the switchgear was assumed negligible.

Type DB Air Circuit Breakers

For Applications up to 600 Volts Ac

Step 3. Symmetrical short-circuit current contributions:

a. Transformer circuit,

$$I_{sym} = \frac{I_B}{Z_p + Z_t} \times 100$$

$$= \frac{2406}{7.75} \times 100$$

$$= 31050 \text{ amperes}$$

b. Motor feedback,

$$I_{sym} = 4 \times 2406$$

$$= 9620 \text{ amperes}$$

Step 4. X/R ratios

a. Transformer circuit:

$$X/R = \frac{5.70}{0.45} = 12.9$$

which is larger than 6.6. Therefore, it is necessary to go to steps 5 and 6.

Step 5. Average asymmetry factors:

a. Transformer circuit from figure 19, page 36, for X/R=12.9, the average asymmetry factor is 1.7 2.

b. Motor feedback: an approximate average asymmetry factor of 1.17 is used.

Step 6. Average rms asymmetrical short-circuit current contributions:

	I_{sym} Symmetrical Current Amperes	Average Asymmetry Factor	avg rms asym. Average, Rms Asymmetrical Current Amperes
Transformer Circuit	31050	1.27	39430
Motor Feedback	9620	1.17	11250
Total at Main Bus	40670	...	50860

It should be noted that in the example of figure 20, by using symmetrical fault currents available at the 480 volts bus, one could use DB-50 selective trip breakers because the total available short-circuit current is less than 42000 rms symmetrical amperes (symmetrical rating of DB-50 breaker). Actually, one has to use DB-75 selective trip breakers because the total asymmetrical short-circuit current is 50860 rms asymmetrical amperes, which is above the 50000 asymmetrical rating of DB-50 breakers.

In most cases the breaker selected by the symmetrical rating (even with X/R of the system larger than 6.6) satisfies also the asymmetrical rating requirements, but it should be remembered that this is not always true, as the example of figure 20 and the example 3 from page 18 illustrate.

Fault Calculations – Single Phase

The calculation of short-circuit currents on single phase ac systems is basically the same as for 3-phase systems as outlined in the preceding sections. The most common form of single phase supply consists of a single phase transformer connected to a 3-phase system.

Figure 21: Typical Single-Phase Transformer Supply

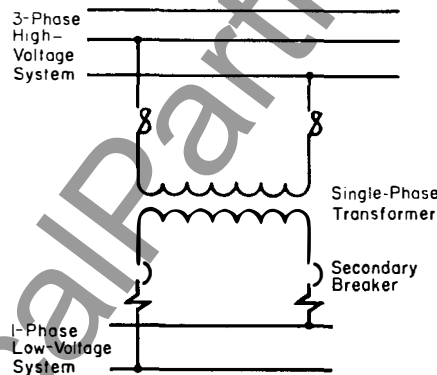

The steps for making the required calculations for such a system are outlined below:

Step 1. Select as a base kva the rating of the single-phase transformer. Calculate all impedance in percent.

Step 2. Calculate the base current I_B on the selected base kva

$$I_B = \frac{\text{Base kva} \times 1000}{\sqrt{3}(\text{rated line-line voltage of the single-phase low-voltage system})}$$

Step 3. Calculate the symmetrical short-circuit current through the transformer to a low-voltage fault by means of the following formula:

$$I_{sym} = \frac{1.73 \times I_B \times 100}{2Z_p + Z_t + Z_c}$$

The derivation of the formula is omitted.

Where I_B is the base current as calculated in (2).

Z_p = Primary system subtransient impedance in percent[ⓐ].

Z_t = Transformer impedance in percent.

Z_c = Impedance of cables or bus runs from the transformer to the point of fault, including the return path.

Note: Z_p , Z_t and Z_c must be added vectorially.

Step 4. Determine the X/R ratio of the transformer and if it is less than 6.6 select the breakers by symmetrical ratings. It should be remembered that motor feedback should be added to the transformer contribution in calculating total short circuit current available.

Step 5. If the X/R ratio is more than 6.6 determine the average asymmetry factor, from figure 19 on page 35, based on the total X/R ratio. Although the average asymmetry factor curve is applied to 3-phase systems (as it averages the asymmetrical currents in the three phases) it can be used for single-phase applications).

ⓐ Just as in 3-phase system calculations, the primary subtransient impedance is based on the available short-circuit kva and is equal to

$$\frac{\text{base kva}}{\text{available short-circuit kva on primary}} \times 100$$

Westinghouse



Figure 22: Typical Single-Phase Transformer Supply with a Tapped Low-Voltage Winding

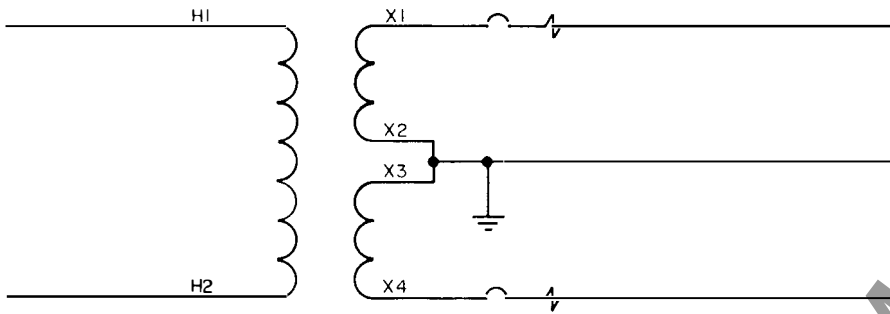

Step 6. The average rms asymmetrical short-circuit current through the transformer is the average asymmetry factor from step 5 times the symmetrical current calculated in step 3. Motor feedback should be added to the fault contribution from the transformer. Select breakers according to their asymmetrical rating.

When the single phase transformer has a tapped low voltage winding or two low voltage windings, such as commonly used for 120/240 volt 3-wire service, the short-circuit current that can flow for a fault from X1 – X2 or X3 – X4, see Figure 22, may be equal to, or may be almost twice as much as a fault on the full secondary from X1 – X4. The exact value will depend on the transformer design. The method for calculating the fault current for a fault across the full secondary winding (X1 – X4) is the same as outlined in the preceding paragraphs.

To calculate the fault current for a half winding fault from X1 – X2 or X3 – X4, the following modifications should be made in the preceding steps:

In Step 2. Base current, I_B , should be based on the half winding voltage (X1 – X2 or X3 – X4) and the full kva base.

In Step 3. The transformer leakage impedance from the full primary winding (H1-H2) to the X1 – X2 or X3 – X4 winding should be used for Z in the equation. This value should be on the full kva base and must be obtained from the transformer manufacturer

Type DB Air Circuit Breakers

For Applications up to 600 Volts Ac

Table V: Tripping Characteristics of Series Overcurrent Trip Devices (Preferred Characteristics are in Bold Print)▲

Breaker Type	Long Delay① Calibrated Marks		Instantaneous Calibrated Marks Pick-up⑤ %	Short Delay Calibrated Marks		Curve No.⑥	
	Seconds	At % of Trip Unit Rating		Pick-up⑦ %	Delay Cycles		
DB-15 & DB-25	25-100⑧	165	200-350 or 250-400			405410	
	12-20	500	800-1200			405122	
	20-30	500	800-1200			405123 ⑨	
	20-30	500	500-1000			351056 ⑩	
	30-40	500	500-1000			405124	
	40-60	500	500-800			405126	
	25-100⑧	165		200-350 or 250-400	6-14-30	351054	
	12-20	500		500-750-1000	6-14-30	405132	
	20-30	500		500-750-1000	6-14-30	405133	
	30-40	500		500-750-1000	6-14-30	405134	
	40-60	500		500-800	6-14-30	405136	
	DB-50	25-150 ⑧	165	200-350 or 250-400			376475
		12-20	600	800-1200			388520
		20-30	600	800-1200			388530 ⑨
20-30		600	500-1000			351057 ⑩	
30-40		600	800-1200			388540	
40-60		600	500-1000			388560	
25-150 ⑧		165		200-350 or 250-400	6-14-30	376474	
6-120⑪		300		300-425⑫	⑬	536915	
12-20		600		500-750-1000	6-14-30	388620	
20-30		600		500-750-1000	6-14-30	388630	
30-40		600		500-750-1000	6-14-30	388640	
40-60		600		500-750-1000	6-14-30	388660	
6-120⑪		600		500-700⑭	⑮	628511	
DB-75 & DB-100		12-20	700	800-1200⑯			405220
	20-30	700	800-1200 ⑯			405230 ⑨	
	20-30	700	500-1000 ⑯			351058 ⑩	
	30-40	700	800-1200⑯			405240	
	40-60	750	800-1200⑯			405260	
	25-150 ⑧	165		200-350 or 250-400 ⑰⑱	6-14-30	458957	
	12-20	700		500-750-1000⑲	6-14-30	405320	
	20-30	700		500-750-1000 ⑲	6-14-30	405330	
	30-40	650		500-750-1000⑲	6-14-30	405340	
	40-60	750		500-750-1000⑲	6-14-30	405360	

▲ Preferred characteristic curves (in bold print) are contained in envelope AD 33-760-A.

① Long delay pickup settings are adjustable with calibrated marks at 80%, 100%, 120%, 140%, and 160% of trip unit rating.

② Nonpreferred characteristics (shown in light print) are available on special order only.

③ Standard for feeder breaker.

④ Standard for transformer secondary and incoming line breakers.

⑤ In choosing instantaneous or short delay pickup settings on these devices, consideration should be given to the minimum as well as the maximum values of the available short-circuit current. This is to make sure that proper protection is provided under all system conditions. For details see paragraph on arcing fault protection on page 20.

⑥ One calibrated mark between 25-150 seconds (specify mark) at 165% of trip unit rating.

⑦ Minimum short delay of 2000 amp trip unit is 250%.

⑧ Minimum instantaneous pickup is 10000 amperes, higher in some ratings.

⑨ Minimum short delay pickup is 5000 amperes.

⑩ Specify any two adjacent long delay timing points listed (see curve).

⑪ Specify one short delay pickup point between 300-425%. A second point will be calibrated at 1.5 times the short delay pickup point selected.

⑫ Specify one short delay pickup point between 500-700%. A second point will be calibrated at 1.5 times the short delay pickup point selected.

⑬ Specify 6 and 14 cycles or 14 and 30 cycles.

⑭ One calibrated mark between 25-100 seconds (specify mark) at 165% of trip unit rating.

Westinghouse



www.ElectricalPartManuals.com