



RECEIVING • OPERATION • MAINTENANCE
INSTRUCTIONS

De-ion[®]
AIR CIRCUIT BREAKER
Type DH

Horizontal Drawout
Indoor and Outdoor Service

AIR CIRCUIT BREAKER TYPE	3-PHASE INTER- RUPTING RATING MVA.	VOLTAGE RATINGS			AMPERES CONTIN- UOUS 60 CYCLES	INTERRUPTING RATINGS—AMPERES	
		Rated KV.	Max. Design KV.	Min. KV. for Rated INT. MVA.		At Rated Voltage	Max. Amperes
50-DH-150-D	150	4.16	4.76	3.5	600	21,000	25,000
50-DH-150-D	150	4.16	4.76	3.5	1200	21,000	25,000
50-DH-150-D	150	4.16	4.76	3.5	2000	21,000	25,000
50-DH-250-D	250	4.16	4.76	3.85	1200	35,000	37,500
50-DH-250-D	250	4.16	4.76	3.85	2000	35,000	37,500
75-DH-250-A	250	7.2	8.25	4.6	1200	20,000	32,000
75-DH-250-A	250	7.2	8.25	4.6	2000	20,000	32,000
75-DH-500-A	500	7.2	8.25	6.6	1200	40,000	44,000
75-DH-500-A	500	7.2	8.25	6.6	2000	40,000	44,000
150-DH-150-A	150	13.8	15.0	6.6	600	6,300	13,000
150-DH-150-A	150	13.8	15.0	6.6	1200	6,300	13,000
150-DH-250-A	250	13.8	15.0	6.6	1200	10,600	22,000
150-DH-250-A	250	13.8	15.0	6.6	2000	10,600	22,000
150-DH-500-A	500	13.8	15.0	11.5	1200	21,000	25,000
150-DH-500-A	500	13.8	15.0	11.5	2000	21,000	25,000

WESTINGHOUSE ELECTRIC CORPORATION
SWITCHGEAR DIVISION

EAST PITTSBURGH PLANT

EAST PITTSBURGH, PA.

SUPERSEDES I.B. 32-150-3

MAY, 1953

Printed in U.S.A.

(Rep. 7-57)



One of the outstanding improvements in modern power distribution has been the development of the air circuit breaker by Westinghouse for distribution circuit voltages. On circuits where the duty on breakers is heavy, long life with a minimum of maintenance makes the De-ion air breaker an outstanding performer. In the type DH magnetic De-ion air circuit breakers, Westinghouse offers a complete standard line for circuits from 2.3 to 15 kv.

Each of the type DH air circuit breakers is three-pole, electrically operated, and is built as a complete horizontal drawout unit for metal-clad switchgear. Breaker units of the same rating are interchangeable so that changing breakers is a matter of minutes. Since they are drawn out horizontally, no lowering or lifting is necessary. Steel barriers and automatic interlocks prevent contact with live parts while the breakers are being changed.

As in the case of most high voltage electrical equipment, these breakers should be inspected and maintained at regular intervals in order to obtain the most dependable performance.

DESCRIPTION

The type DH air circuit breaker is a three-pole, electrically operated, horizontal drawout unit for metal-clad switchgear. In the type designation, the numbers preceding DH indicate the voltage rating in hundreds of volts, and the numbers following DH indicate the maximum interrupting rating in thousands of kva. The various ratings have similar structural features and many parts in common.

Fig. 1 shows a type-150-DH-250A breaker with the main barrier assembly and one arc chute removed. This shows clearly the arrangement of the arc chutes and blowout magnet assemblies, the contacts and insulated operating rods, and the solenoid operating mechanism. These components are supported in a welded steel frame mounted on flanged wheels for guiding it into the metal-clad cell. In the lower part of the frame also is located the levering-in device for moving the breaker into final contact engagement. This device is interlocked with the mechanism to prevent inserting or withdrawing the breaker with the contacts closed. Also located in the lower part of the frame are the secondary contacts for automatically disconnecting the control wiring when the breaker is withdrawn, the auxiliary switch, and other auxiliary devices.

A barrier assembly is placed on the breaker before it is rolled into its cell. The front sheet is of one-eighth inch steel to form a grounded barrier between personnel and live parts when the unit is in the cell. On 15 kv breakers this barrier assembly is in two parts for convenience in handling.

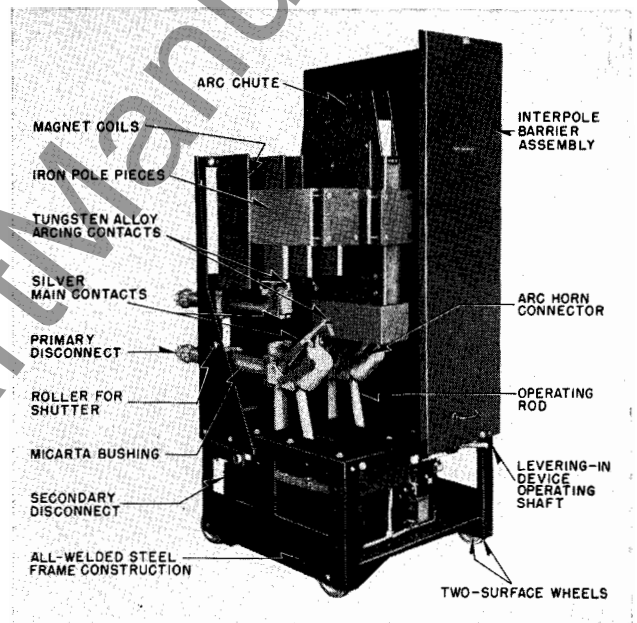

FIG. 1. Type 150-DH-250A Circuit Breaker with Half of Main Barrier and One Arc Chute Removed

RECEIVING, HANDLING, STORING

All type DH breakers are assembled and given operating tests at the factory, after which they are carefully inspected and prepared for shipment by workmen experienced in the proper handling and packing of electrical equipment. In order to afford maximum protection against damage, the main barrier assembly and the arc chutes are packed separately. For each three-pole breaker there is one barrier assembly and three arc chutes.

After the equipment has been unpacked, make a careful inspection for any damage which may have occurred in transit. If the apparatus has been

damaged, file a claim immediately with the carrier and notify the nearest Westinghouse Sales office.

HANDLING

Remove the crating and packing carefully to avoid damage from negligent handling of crowbars or other tools. Use a nail puller for the uncrating. Care must be used in handling the arc chutes, since the splitter plates within them are made of a ceramic material which may break if dropped.

The base of the crate may be used as a skid for moving the breaker, or the breaker may be lifted

RECEIVING, HANDLING AND STORING

with slings under the crate. If the breaker is to be lifted with slings, move it while it is still crated. After the breaker is unpacked, the best way to move it is by rolling it on its own wheels.

If it is necessary to lift the breaker after it is uncrated, lift it without the arc chutes or barriers in place. Slings may be placed under the breaker frame or in holes provided in the frame. Use a spreader to prevent the cables from distorting the blowout magnets.

STORING

The arcing chambers are shipped in separate containers to guard against damage from rough handling and for better protection from dust and water or liquids. Store them in their shipping containers until ready for use.

Store all components of these breakers in a clean dry place. During the storage period, keep them sufficiently warm to prevent moisture condensation.

TABLE OF APPROXIMATE WEIGHTS
(In Pounds)

BREAKER TYPE	AMPERE RATING	BREAKER WITHOUT CHUTE & BARRIER	SINGLE ARC CHUTE	BARRIER ASSEMBLY	COMPLETE BREAKER
50-DH-150-D	600-1200	875	45	75	1085
50-DH-150-D	2000	1050	45	95	1280
50-DH-250-D	1200	875	45	75	1085
50-DH-250-D	2000	1050	45	95	1280
75-DH-250-A	1200-2000	1400	65	160	1750
75-DH-500	1200-2000	1600	105	160	2075
150-DH-150-A	600-1200	1250	70	160	1620
150-DH-250-A	1200	1250	70	160	1620
150-DH-250-A	2000	1400	70	160	1770
150-DH-500-A	1200	1450	105	160	1925
150-DH-500-A	2000	1600	105	160	2075

INSTALLATION

With the exception of the arcing chambers and barriers, these breakers are shipped completely assembled and adjusted. No adjustments should be required and none should be made unless obviously needed.

When the breaker has been removed from the crate, remove braces which support the blowout magnet pole pieces during shipment.

Caution: Severe injury may be sustained if any part of the body is struck by the contact arms since they move very rapidly on the opening stroke. Personnel working about the breaker should stay clear of the space in which the contact arms move while breaker is closed or is being closed. If breaker has been closed by hand, always remove hand closing lever before tripping.

The following sequence of operations should be performed in preparing the breaker for use:

1. Breakers are usually shipped with the contacts closed and with a tie on the trip lever to pre-

vent tripping. After the breaker is unpacked and the shipping ties and braces removed, take off the tie on the trip lever and trip the breaker. Then close the breaker carefully by hand, using the removable hand closing lever. Make certain that all parts are functioning properly and that there is no binding or excessive friction. As the contacts touch near the end of the closing stroke, the force necessary to close the breaker increases rapidly.

2. With the breaker in the closed position, check the contacts to make certain that the adjustments have not been disturbed. For proper settings, refer to the section of Fig. 6 which matches the contact design of the breaker being installed. If adjustments are required, they may be made as described on page 9.

A light film of grease is applied to both the arcing and main contacts before the breaker is operated at the factory. This film is normally removed before shipment. Before the breaker is placed in service, inspect all contacts to see that they are free of oil or grease.

3. The breaker is more easily handled with the arc chutes and barriers removed; mount these parts after the breaker has been moved near the metal-clad cell structure.

Before installing the arc chutes, play a stream of dry compressed air through them from each end to remove any dust or foreign matter. Then examine the chutes to make certain that the vents and slots are open and free from foreign material. Assemble the arc chutes on the breaker by removing the retaining straps from the front of the magnet pole pieces and sliding the chutes into position, making sure that the rear arcing horn connectors properly engage the contacts on the blowout coils.

After a chute has been placed in position, make sure (1) that it is centrally located so that there is no interference with the travel of the moving contacts and (2) that it is securely held in position by the retaining strap with top of the chute parallel to the top of the laminated pole faces. Connect the shunt strap to the front arcing horn in the chute. Tighten the lower connection of the shunt strap since it may have loosened during transit. The arc chute is now completely installed. Make a final check by operating the breaker slowly by hand to see that there is no interference in the movement of the moving contact.

4. The interpole barrier assembly should now be put in place. The 5 kv breakers have a one piece assembly. Blowout magnet micarta channels have their front edges beveled to help guide barrier plates into place. The lower rear corner of the outside micarta plate goes inside the steel gusset of the frame. The front steel sheet of the barrier assembly is centered on the breaker by a notch on the bottom edge at the middle, which should engage a locating pin on front edge of breaker frame. Two bolts at lower front corners hold assembly in place.

Because of size and weight the interpole barrier assembly on the 15 kv breakers is divided in two parts. Right half goes on first. The front steel sheets are aligned by two locating pins at lower front corners and single bolt at top center. Two bolts at lower front corners hold assembly in place.

5. The breaker is now ready to be operated electrically. Each breaker should be closed and tripped electrically several times before being connected to high voltage. These operations may be made at the test position in the cell or by means of other test facilities provided. See page 12 of this instruction book and I.B. 32-150-4, page 33, for information concerning placing the breaker in the cell. The hand closing lever must always be re-

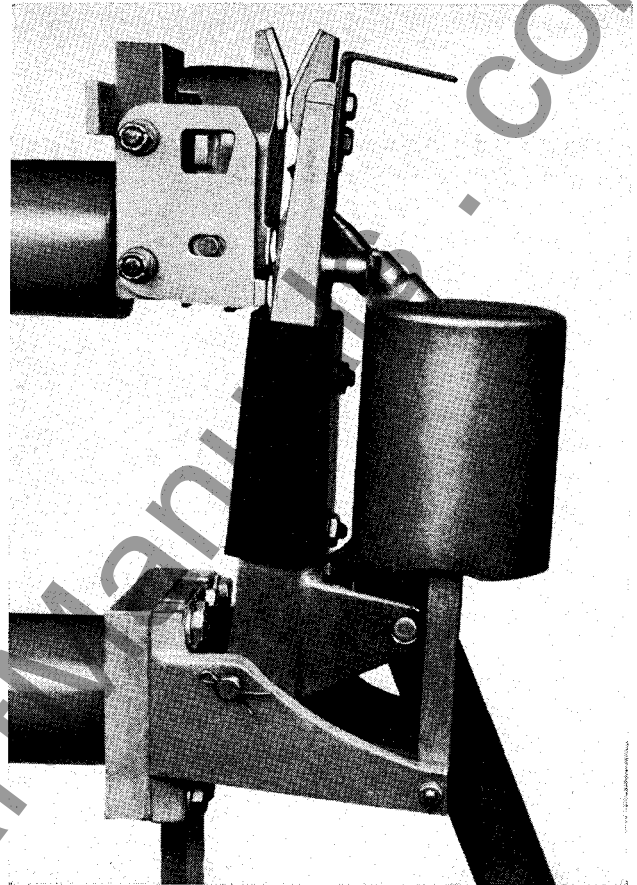

FIG. 2. Typical Contact Assembly Shown in Closed and Latched Position

moved from socket in mechanism before making electrical operation. If electrical operation is quick and positive on both close and open, breaker is now ready to be levered into operating position.

Caution: Do not attempt to close by hand, against an energized circuit, any breakers covered by this instruction book. To insure sufficient closing force and speed, these breakers should be closed electrically from an adequate power source. See NEMA Standard SG 6-213.

When this drawout equipment is put into the cell and moved in beyond the test position, the high voltage parts of the breaker will be energized. If the barrier is completely assembled on the breaker, personnel will be protected from contact with the live parts. If, however, the barrier assembly is left off and the breaker rolled into the cell, live parts are exposed. The breaker should never be rolled into an energized cell structure beyond the test position without having the complete barrier assembly in place.

OPERATION AND ADJUSTMENT

Before adjusting a circuit breaker, it is advantageous to become familiar with the construction and function of the various parts. The following paragraphs describe the operation and the various adjustments which can be made. This material should be studied carefully before doing any work on the breaker.

The general arrangement of the breaker components is shown in Fig. 1. The solenoid coil is built to exert a horizontal force on the mechanically-trip-free linkage. This linkage, in turn, exerts an upward force on the pole unit insulating operating rods. The moving contact arms carry the main, intermediate, and arcing contacts. On opening, these contacts separate in the order named; on closing, they touch in the reverse order.

On the outer ends of the condenser bushings are clusters of finger contacts for engaging the main circuit contacts in the cell. Above the arcing contacts are located the blowout magnets and arc chutes. The breaker is tripped by lifting the tripping trigger either manually, or electrically by means of the trip coil.

OPERATING MECHANISM

The solenoid operating mechanism with its trip-free linkage is shown in Fig. 4. In this mechanism the horizontal pull of the solenoid coil is transmitted to the contact operating rods through a system of links which rotates counter-clockwise about the operating center. The linkage system consists of four major links: the non-trip free lever, trip free lever, upper trip free link, and lower trip free link. These members are arranged as shown and are held to form a rigid member by the cam link and tripping cam. The tripping cam is held fixed by the tripping latch.

When the solenoid is energized, it pulls on the junction of the non-trip free lever and the lower trip free link, causing the system to rotate about the operating center. The trip free lever then exerts an upward force on the operating rods through the cross bar to close the breaker. The breaker is held in this position by the closing latch and the tripping latch.

The breaker is tripped either electrically or manually by lifting the trigger which disengages the primary latch. This allows the tripping latch to release the tripping cam so that it is free to rotate. Without the restraining force of the cam and cam

link, the major linkage collapses under the force of the contact springs and the accelerating springs which are located in an air bumper attached to the trip free lever. The junction of the upper and lower trip free links moves to the right and the trip free lever rotates clockwise, thus opening the breaker. The position of the linkage is then that shown in Figure 4-B.

In moving to this position the roller on the lower trip free link has disengaged the closing latch. The retrieving springs now move the solenoid core which moves the linkage to the reset position as shown in Figure 4-C. In this position the tripping latch is reset and the breaker may be reclosed.

MECHANISM PANEL

The mechanism panel is mounted on the front of the closing solenoid mechanism as shown in Fig. 3. On it are mounted the following auxiliary devices included as standard on all breakers:

Shunt Trip Magnet. This device may be equipped with a coil for direct current or alternating current or capacitor tripping.

Cut-Off Switch. This switch causes the supply to the closing solenoid to be cut off after the breaker is closed.

Position Indicator. This device gives positive indication of the position of the breaker contacts.

Operation Counter. This counter records each operation of the breaker.

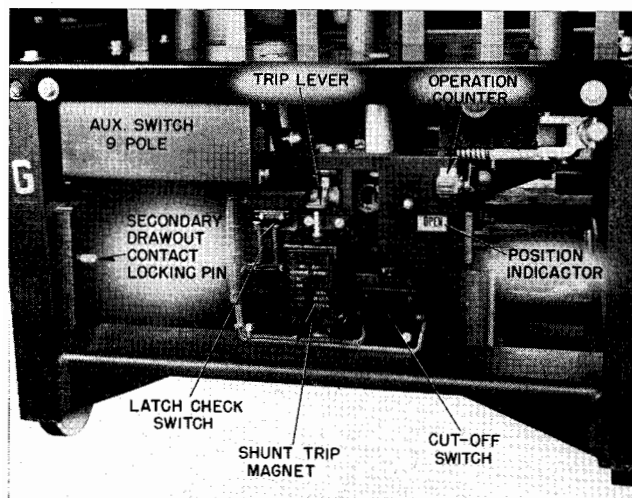

FIG. 3. Mechanism Panel

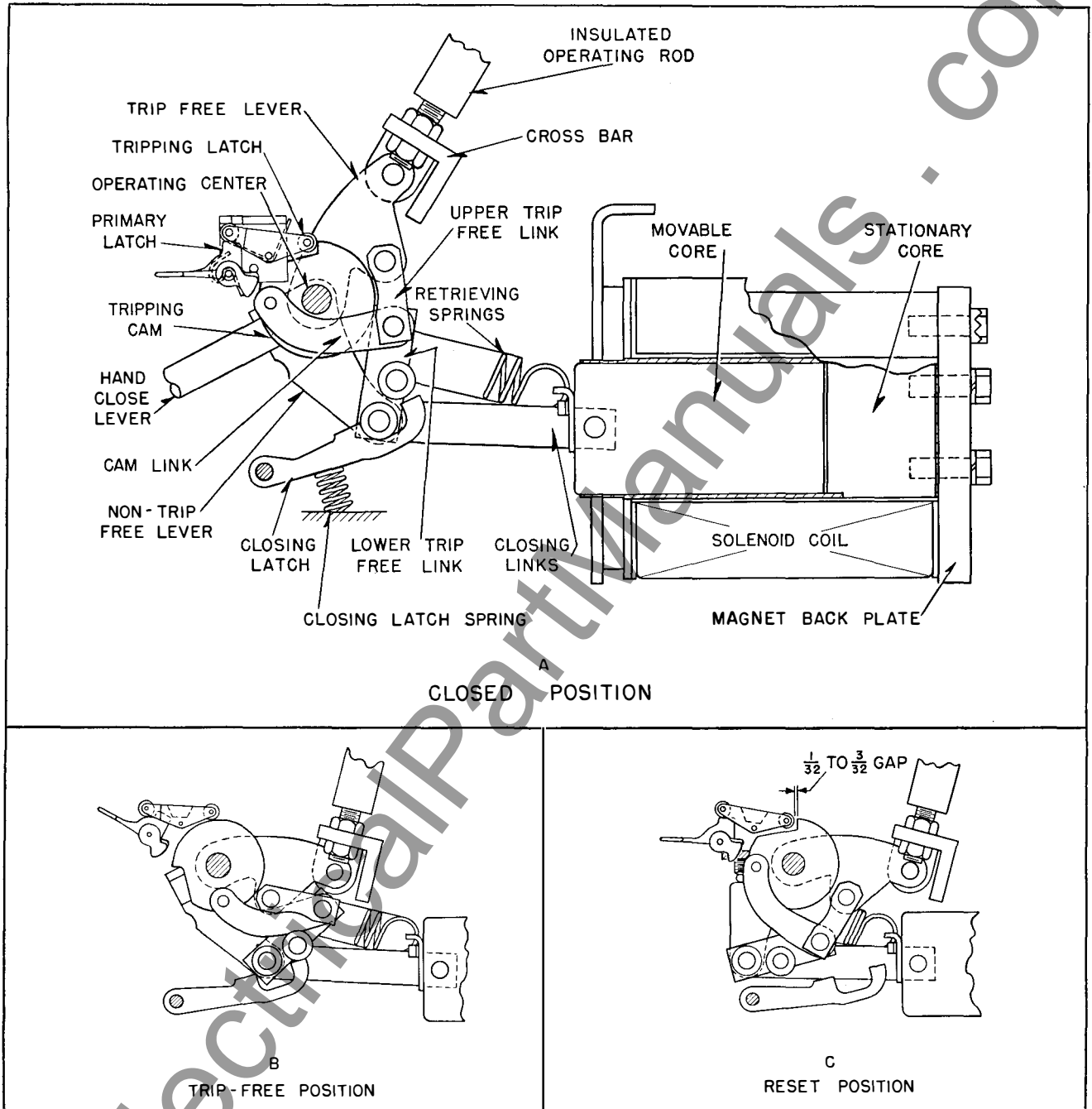

FIG. 4. Solenoid Operating Mechanism

The following special devices may also be mounted on the mechanism panel when required:

Undervoltage Trip Attachment. This is a magnetically held device which when released will trip the breaker using energy stored in a spring during the mechanism retrieving motion. For instantaneous release, the holding magnet coil may be connected to d-c with a series resistor to suit the voltage or it may be supplied with low voltage d-c from an a-c control voltage through a small

transformer and rectox assembly mounted in the cell structure. For time delayed release, a special very high resistance coil is used in the holding magnet and it is supplied with about 300 volts d-c from a transformer, rectox, and capacitor assembly mounted in the cell. The capacitor is connected across the coil and provides a slowly decaying holding current. See Descriptive Data sheet 33-131. The holding magnet is mounted on the mechanism panel to the left of the shunt trip magnet.

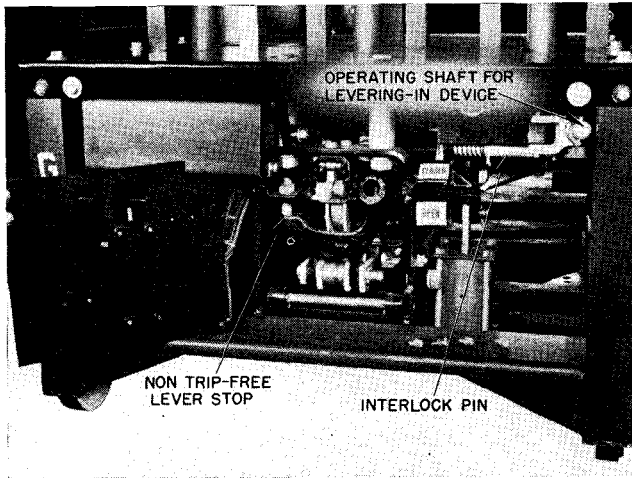

FIG. 5. Operating Mechanism—Panel Removed

Latch Check Switch. When a breaker is to be automatically reclosed after being tripped free, it is necessary to arrange the electrical control scheme so that the closing solenoid will not be energized to start the closing motion until the mechanism has completed the linkage motions to get to the reset position. See "B" and "C" of Fig. 4. For this purpose, a switch is arranged to be closed when the primary latch or trigger handle moves to the reset position, because the trigger is the last part to move in the sequence of linkage motions required to reset the mechanism. To keep necessary tripping force small, the resetting spring torque used on the trigger is small. Therefore, the latch check switch is a small, light force, snap action switch. See Fig. 3.

MECHANISM ADJUSTMENTS

The mechanism in the Type DH air circuit breaker is adjusted at the factory and is designed to give long trouble-free performance. Do not make any adjustment unless faulty operation is observed.

Tripping Latch. If a breaker fails to close contacts although the moving core of the mechanism moves to the closed position, a probable cause is failure to reset. Refer to "C", Fig. 4. The gap indicated between tripping latch roller and cam is an essential requirement to permit tripping latch roller to fall into cam notch. Watch trigger handle (with words "lift to trip"). It should return to horizontal position, immediately after breaker has opened.

If trigger is prevented from returning to full reset condition by primary latch roller above it, cause

may be that tripping latch roller cannot drop into cam notch. Remove front half of horizontal panel forming seat of the chair in the frame. This gives easy access to the gap. Using hand closing lever, close breaker part way, trip, and then slowly retrieve moving core. Note whether or not tripping latch roller drops into cam notch.

If necessary to increase clearance to get $\frac{1}{32}$ inch minimum, remove front panel as follows. Remove spring from operating arm of counter. Remove four bolts and then turn panel as though hinged at left edge to prevent damage to wiring. Set out of way as shown on Fig. 5. There is no need to remove wiring. The non trip free lever stop is now accessible. Loosen lock nut and adjust stop bolt until cam to roller clearance is within limits. Hand closing lever should be out of socket during this adjustment. When returning panel, be sure to get cutoff switch arm into correct position through window.

Cut-Off Switch. Operation of this switch must occur at proper time in closing stroke. Contacts must make positively before end of motion so that current will always be cut off. In other direction, cut off must not occur too early in stroke or mechanism might fail to complete closing stroke. Proper action will be obtained when switch plunger has $\frac{1}{32}$ to $\frac{1}{8}$ -inch overtravel. In other words, between position where contacts touch and position with breaker closed and latched at rest, there should be $\frac{1}{32}$ to $\frac{1}{8}$ inch motion of switch plunger. Ordinarily no adjustment is required. The resilience provided in the operating arm, by leaf springs, prevents damage to the switch on the mechanism overtravel. If it should be necessary to change switch contacting time, bend rear heavy portion of switch operating arm. Do not bend leaf springs.

Latch Check Switch. The action of this switch may be checked as follows. Breaker being open, raise the trigger "Lift to Trip" arm to end of travel. Lower slowly, listening for snap action. Note position of arm when switch snaps closed. Switch should close when trigger arm is in interval $\frac{3}{8}$ to $\frac{1}{8}$ inch above normal reset rest position measuring at the shunt trip plunger centerline. A convenient method of measuring this is to raise and lower trigger arm by pushing with the trip plunger and making pencil marks on the plunger rod. If breaker is out of cell, switch action may be indicated electrically from drawout plugs number 17 and 18. If switch action must be made earlier or later, bend switch arm near the middle of its length.

CONTACT ADJUSTMENT

Four designs of contacts are shown in "a", "b", "c" and "d" of Fig. 6 on page 11. The different designs are used on different ratings. Compare the breaker to be adjusted with the four views in Fig. 6 and choose the one which applies.

Fig. 6-a. In this design, bridge contacts are resiliently attached to the moving contact arm by means of two studs with adjustable nuts behind the moving arm. The three sets of contacts, main, intermediate and arcing part in that order, and when closing, touch in the reverse order.

The main contacts are made from a silver-nickel alloy. The intermediate and arcing contacts are made from a tungsten silver alloy, which has high resistance to erosion by the arc. The stationary intermediate and arcing contacts are brazed to a casting mounted on springs on the upper bushing. The casting is connected to the bushing by a flexible shunt, and is supported between guide plates with stop surfaces so arranged that on breaker opening motion the arcing contact follows the moving contact farther and thus parts last.

In addition to the contacts, the moving contact arm also carries the puffer which supplies a puff of air through the nozzle under the moving arcing contact each time the breaker operates. This air serves to speed circuit interruption at low currents where the effect of the magnetic blow-out coils is lessened. It has no appreciable effect in opening high currents.

Arcing Contacts. To assure the proper compression in the arcing contact springs, these contacts should be adjusted so that, with the breaker closed, the dimension from the contact surface to the front surface of the stud block is between $1\frac{1}{16}$ and $1\frac{3}{16}$ inches. This adjustment is made by turning the nuts which attach the insulating operating rod to the crossbar.

When the contacts have been properly adjusted, the arcing contacts should touch on all three poles at approximately the same time in the closing stroke. It is satisfactory, if, when the first pole touches, the greater distance between arcing contacts on other two poles is not more than one-fourth inch.

Main Contacts. The main contact bridges are held in place on the moving contact arm by studs which pass through the main contact springs. Adjustment of the main contacts should be made after

arcing contacts have been adjusted. With the breaker in the closed latched position, set the stop nuts on these studs so that there will be one-sixteenth inch clearance between face of nut and the back of the moving contact arm.

If no clearance is present at these points, main contact pressure may be lacking or absent, thus forcing load current through the intermediate and arcing contacts. This can result in overheating and damage to the contacts. If new contacts are being installed or if the contacts have been smoothed, it is well to operate the breaker electrically several times so that the surfaces assume their permanent shape before this adjustment is made.

Fig. 6-b. In this contact design, the moving contact arm and the puffer cylinder are cast in one piece. The springs which apply pressure to the main moving contacts are hidden in a recess in the moving arm casting. In Fig. 6-b, note that there is an elongated hole, hidden from view, in each main contact bridge.

There is just one adjustment on this contact arrangement, namely the pushrod length. This length must be such that the pin through the contact bridges moves approximately $\frac{1}{16}$ inch from the end of the elongated hole in the bridge when breaker is closed and latched. To determine that adjustment is correct, measure relative motion of bridge into contact arm casting. With hand closing lever, move contact arms toward closed position until main contacts are just about to touch. Measure relation of bridge inner curved surface to machined edge of contact arm casting near pin. Close and latch contact. Repeat measurement. Bridge should move into contact arm $\frac{1}{16}$ inch. When necessary to readjust, change pushrod length by moving nuts at lower end of rod where it attaches to crossbar. Be careful to lock nuts tightly after finishing adjustment.

Fig. 6-c. In this contact design, the main moving contact is bolted solidly to the moving contact arm. All resilience is put in the stationary contact members. Conductivity from lower bushing to moving main contact is through a flexible shunt at contact arm hinge point. Lower main and upper main contacts are made of a high conductivity silver alloy. The arcing contacts are made of an arc refractory tungsten silver alloy.

The stationary arcing, and upper main contacts are brazed to a casting which is supported between

two guide plates which are part of the lower main stationary contacts. The upper main and arcing contact casting is connected to the bushing block by a flexible shunt and it is backed by contact pressure springs. The side plates carrying the lower main contact are pivoted at the upper mounting pin. At the lower pin hole, clearance is allowed so that plate may move giving some resilience to the lower main contact. The surface of the side plates next to the bushing block is silver plated as is the block. The plates are pressed against the block with springs on the mounting pins. Holes in the side plates engage small bosses on the stationary arcing contact casting to form stops for the casting so that the proper sequence in contact parting is obtained.

Side Plates. Two different designs of contact side plates have been supplied for the contact design shown in Fig. 6-c. (See Fig. 6-c, Details "X" and "Y"). Compare breaker being checked with X and Y of the detail. Note the difference in the shapes of the holes in these side plates. On Detail "X", the lower main contact should travel $\frac{1}{16}$ inch (minus zero, plus $\frac{1}{32}$). On Detail "Y", the lower main contact should travel $\frac{3}{32}$ inch (minus zero, plus $\frac{1}{32}$). Adjustment to get these travels is obtained by means of the nuts at the lower end of the operating rods. The arcing contacts of the three poles should touch at approximately the same time, but it will be satisfactory if, when the first pole touches, the greater distance at either of the other poles does not exceed $\frac{1}{4}$ inch. Correct main contact travel is more important than simultaneous touching of the three poles.

When replacement lower main contacts are ordered, they will be supplied on side plates as shown in Detail "Y". If original plates are like Detail "X", sufficient pieces should be ordered to change both sides on all poles of a breaker.

Fig. 2 on page 5 is a photo of the same contact assembly as that shown in Fig. 6-c. The contacts are in the closed and latched position. When the contacts open, the lower mains part first, then upper mains, and finally the arcing contacts part. When the contacts close, the arcing contacts touch first, then upper mains, and finally the lower mains.

Fig. 6-d. In this contact design, the moving contacts are solidly bolted to the moving contact arm. All resilience is put in the stationary contact member. Conductivity from lower bushing to moving main contact is through a flexible shunt at contact arm hinge point. Main contacts are of a high con-

ductivity silver alloy. Arcing contacts are made of an arc refractory tungsten silver alloy. The stationary arcing and main contacts are brazed to a casting which is supported between two guide plates that in this case are rigidly bolted to the bushing block. This stationary contact casting is connected to the bushing block with a flexible shunt and the casting is backed by contact pressure springs. Note that the travel of the stationary main contact should be $\frac{1}{8}$ inch plus or minus $\frac{1}{32}$. Adjustment for this is obtained by means of the nuts at the lower end of the operating rods.

ARC CHUTES AND BLOWOUT MAGNETS

The arc chute on the type DH air circuit breaker consists of an assembly of insulating refractory plates enclosed in a rectangular Micarta tube or jacket. In position on the breaker, the jacket is between the poles of the blowout magnet and the lower end is immediately above the arcing contacts.

The refractory plates have inverted V-shaped slots starting immediately over the arcing contacts so that the arc is drawn into these slots. The slots in the plates are alternately off center on opposite sides to increase the length of the arc path as the arc progresses up the chute.

Inside the front and rear surfaces of the chute are metallic arcing horns to which the arc transfers from the arcing contacts. The front horn is connected electrically to the moving contact, the rear horn through the blowout coil to the stationary contact. Thus when the arc transfers to the horns the blowout coil is included in the circuit.

The action of the breaker in interrupting an arc is shown in Fig. 7. When the arcing contacts separate, an arc is drawn between them without the blowout coil carrying current as indicated by position 1. The arc rises rapidly from this position under the influence of magnetic forces and thermal air currents. These cause the arc to impinge on the arcing horns, thus including the blowout coil in series with the arc.

When current starts to flow in the blowout coil, the arc is driven very rapidly into the slots in the refractory plates by the magnetic field. Successive positions of the arc are shown in Fig. 7.

Because the slots are staggered, the arc is lengthened as it progresses up the chute by being extended laterally from one slot to the next. This exposes a large part of the arc to the relatively cool surfaces of the plates and to the de-ionizing effect of the blowout magnet field, which results in fast and positive interruption of the circuit.

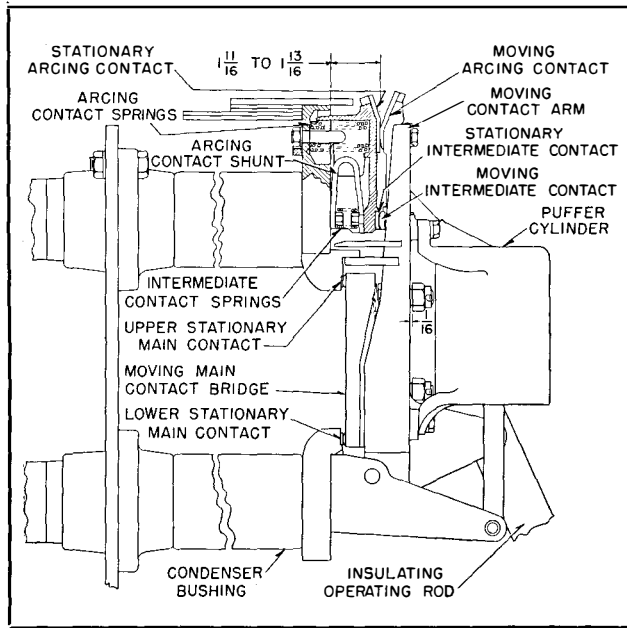

FIG. 6-a

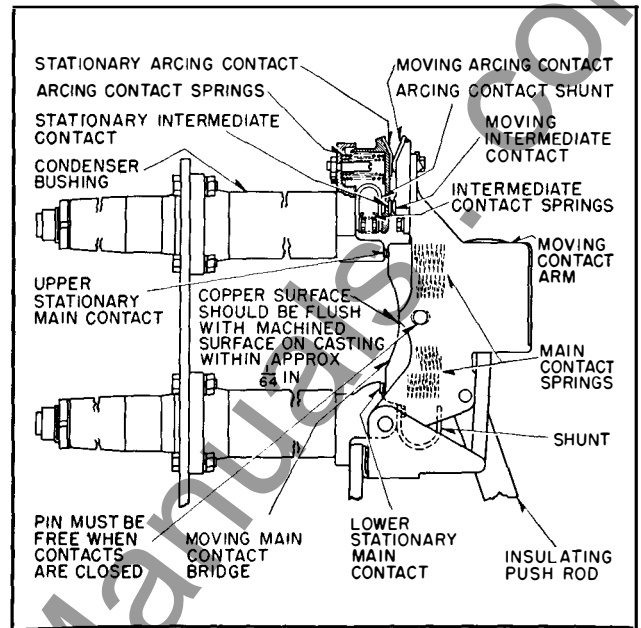

FIG. 6-b

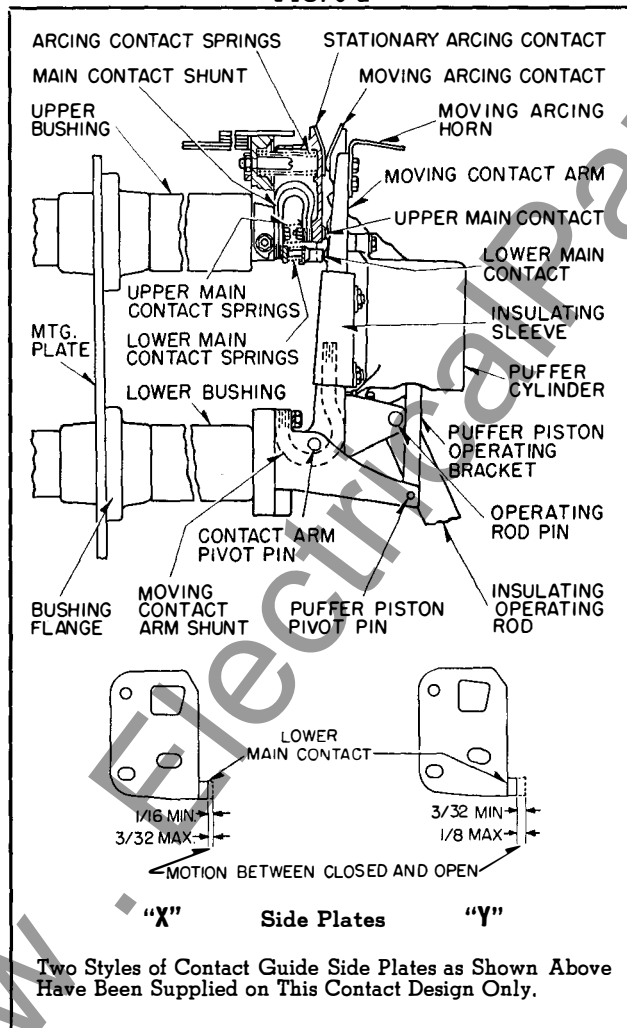

FIG. 6-c

Two Styles of Contact Guide Side Plates as Shown Above Have Been Supplied on This Contact Design Only.

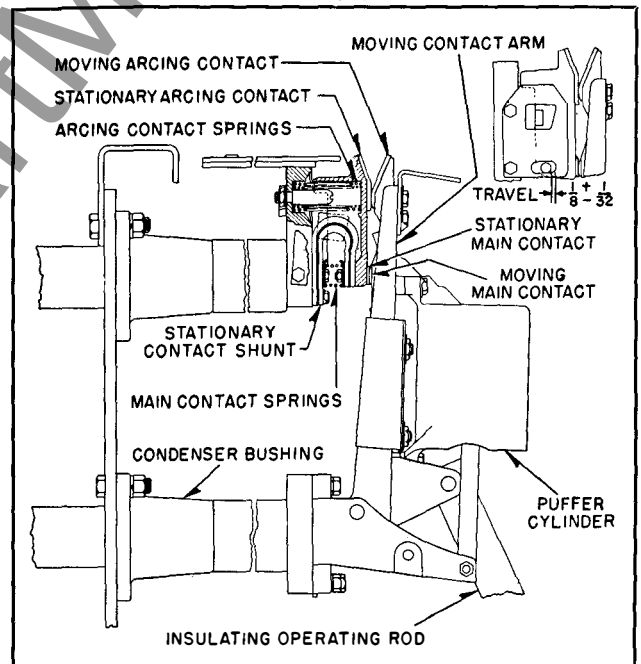

FIG. 6-d

FIG. 6. Contact Adjustment Dimensions for Four Different Breaker Contact Designs.

(Compare the breaker to be adjusted with the four views on this page and choose the one which applies.)

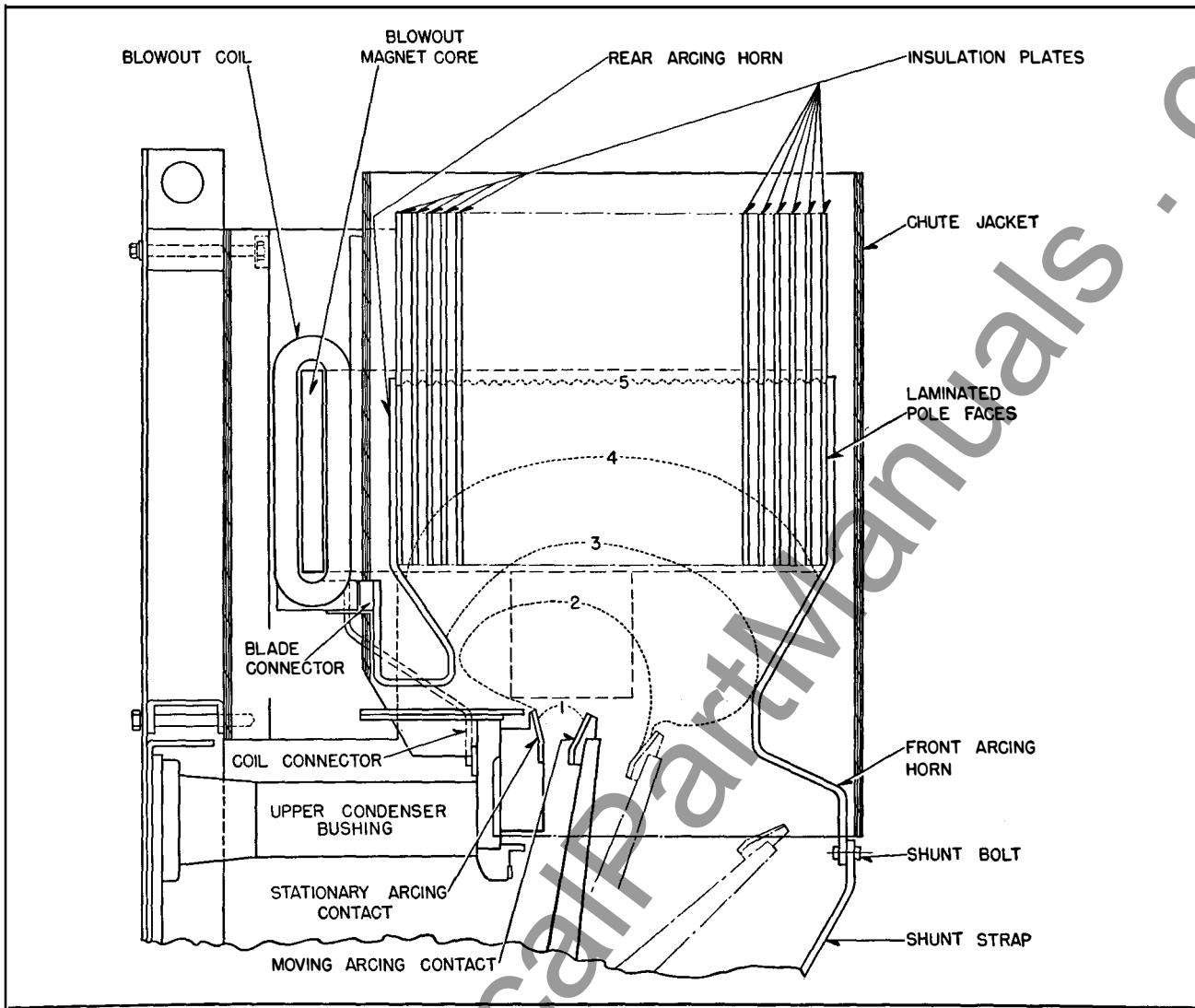

FIG. 7. Arc Chute and Blowout Coil.

HORIZONTAL DRAWOUT ARRANGEMENT

All type DH air circuit breakers are arranged or use in metal-clad equipment from which they may be drawn out horizontally. As may be seen in Fig. 9, all parts are supported on a steel frame with four wheels with roller bearings to facilitate moving the breaker, and flanges which engage with rails to align the breaker in the cell.

The main conductors project horizontally from the rear of the breaker, and are supported and insulated from the steel back plate of the frame by Micarta condenser bushings. On the ends of these main conductors are circular clusters of contact fingers arranged to engage the circular bar conductors in the cell.

The control circuit wiring also is arranged for drawout disconnection by means of an 18-point

connector block arranged to plug into a mating block mounted on the cell. This secondary connector block is mounted on a movable bracket on

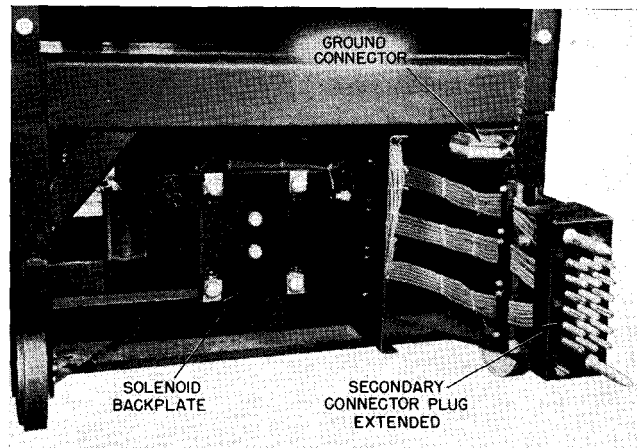

FIG. 8. Secondary Connector Plug Extended

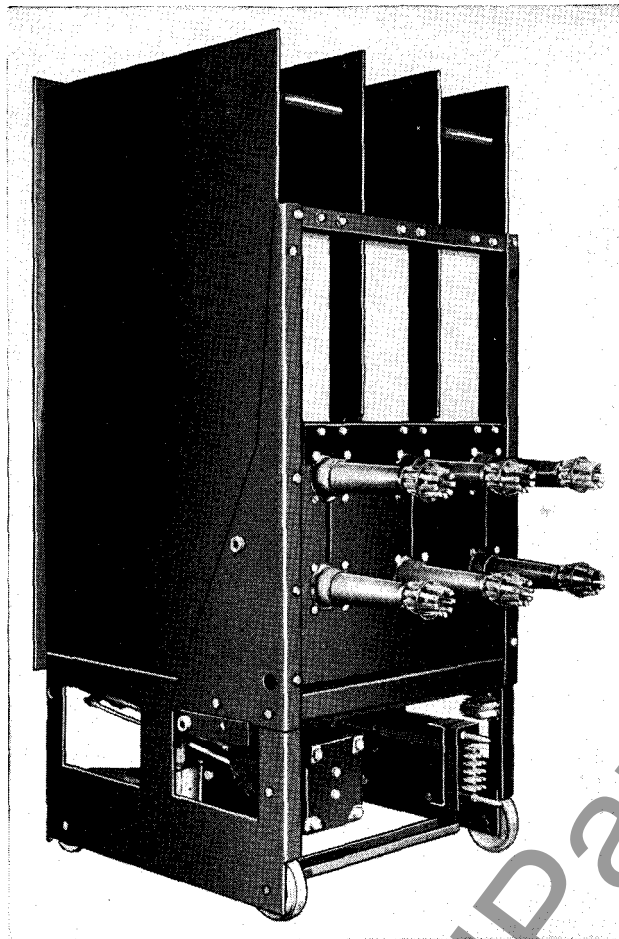

FIG. 9. Rear View of 150-DH-250 Circuit Breaker.

the lower left-hand side of the breaker frame. This permits the plug-in connector to be extended to the rear of its normal position so that the control circuits may be connected and the breaker operated electrically while the main contacts are disengaged. See Fig. 8.

This test position occurs at the outer limit of breaker travel obtained by operation of the levering-in device crank. If it is desired to connect the control circuits when the breaker has been cranked to this position, pull out the secondary contact locking pin shown in Fig. 4. While holding this pin out, push the secondary contact bracket toward the rear of the breaker until the secondary contacts engage fully. The main barriers may be removed and the breaker operated safely in this position since the main contacts are disconnected.

When the breaker is in the cell far enough to be connected to the high voltage bus, the frame work of the breaker is effectively grounded by a special connector located immediately above or below the secondary plug-in connector block. This connector

jaw engages a copper bar which is mounted in the cell and connected to the cell ground bus.

Levering-In Device. In order to move the breaker in or out of the cell against the resistance of the contact fingers, a levering-in device is provided on each breaker. There is a lever on each side mounted on a common shaft across the back of the breaker. On each lever is a roller which engages a groove on the side wall of the cell. A removable crank engages another shaft at the right front corner of the breaker which turns the levers through a worm gear arrangement.

Before a breaker is rolled into a cell, the levers with rollers at each side of the breaker must be at their rear and slightly down position as shown in Fig. 10. The position of the levers shown in Fig. 9 is that which the levers take after the breaker is cranked into operating position. To put the levers in the position shown in Fig. 10, place the crank on the operating shaft at front right corner of breaker. Press in and rotate to engage slot. Breaker must be open to engage slot. Rotate crank counterclockwise to the end of travel against solid stop. With levers

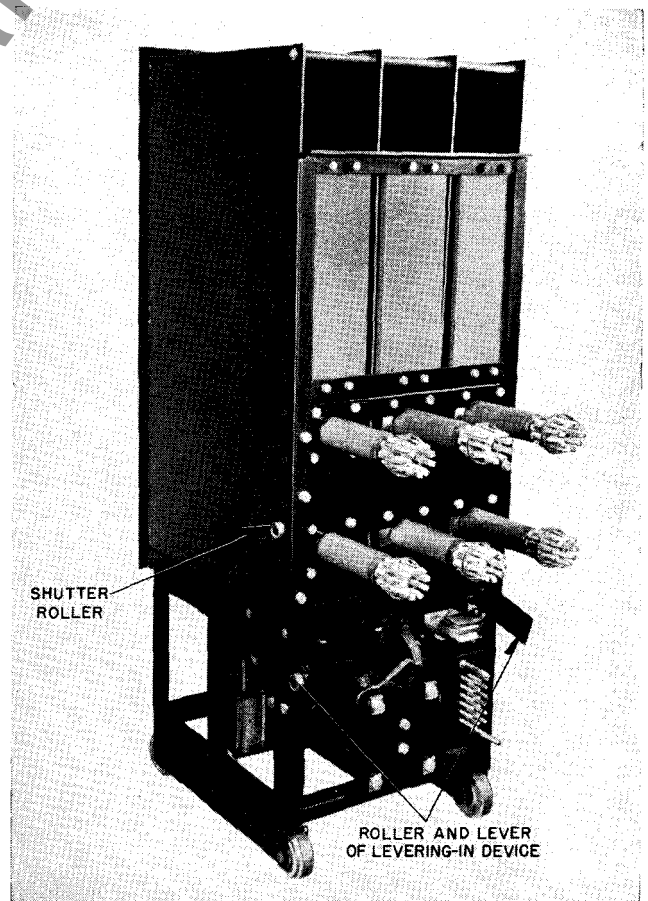

FIG. 10. Rear View of 50-DH-250D Breaker Ready to Roll Into Cell

OPERATION AND ADJUSTMENT

to the rear and down as in Fig. 10 the breaker is ready to be rolled into cell as far as the test position. The rollers on the levers strike a vertical angle on the cell wall and stop the breaker at the test position. If the breaker is to be operated at this position, remove the crank, and push in the secondary control connector as previously described.

To move breaker from test position into fully engaged operating position, put crank on shaft. Push in and rotate to engage. Crank clockwise. Torque required will increase slightly when primary connector fingers engage the stud in the cell. Continue cranking until lever shaft meets solid stop.

Remove crank. If the cranking operation was completed, removal of the crank will permit the interlock pin, see Fig. 5 (also "A", Fig. 36 in I.B. 32-150-4), to withdraw from the trip-free lever in the mechanism.

To remove a breaker from operating position, first check that breaker has been opened. Put crank on operating shaft. Push and rotate to engage. Turn counterclockwise until stop is reached. Remove crank. Again the interlock pin will withdraw from the trip-free lever if the cranking operation was completed. Breaker may now be operated at the test position or rolled out of cell.

MAINTENANCE

Westinghouse type DH air circuit breakers are designed to have a long life with a minimum of maintenance when operating duty is ordinary or average. However, the operating duty will vary greatly as to frequency of operation and as to size and power factor of current interrupted, with the many types of applications of these breakers. Therefore, the frequency of inspection and the amount of maintenance for any particular application must be chosen with due regard to the kind of duty a breaker is performing. The following remarks are intended as a general guide. Experience on a particular application may show a need for different maintenance practices.

Breakers which operate only a few times per year with light to medium currents being interrupted, will require only light routine maintenance. This maintenance should consist of a general inspection and a cleaning of deposited dust and dirt particularly from insulation surfaces, and a few "exercising" operations. When making these exercising operations, observe the mechanical motions to be sure they are quick, snappy, and positive and that there is no tendency of any parts to stick. If there is any stickiness or sluggish motion, operate slowly by hand to locate the place with high friction. See paragraphs on "Lubrication", page 17. It is recommended that breakers which remain closed continuously without any automatic operations, be tried for proper operation at least once a year.

For breakers which operate a moderate number of times, say 100 to 1000 per year, mechanical stickiness is unlikely to develop and there will be no need for exercising operations. However, on inspections, more attention should be paid to clean-

liness of the interrupter especially if there are many fault current interruptions. Large current arcs glaze the ceramic surfaces inside the arc chute but leave them clean electrically. On the other hand, frequent operation at low or medium currents (about 1000 amperes or less) tends to cause the accumulation of soot and condensed metal on the parts inside the arc chute, particularly on the ceramic arc shields near the contacts. These deposits may be conducting and may have to be removed as explained later under "Arc Chutes".

Breakers which have opened large fault currents near the maximum rating, should be inspected as soon as practical. The condition of the contact surfaces and the contact pressure adjustments should be checked. (See page 15, "Contacts".) Also the interior of the arc chutes should be inspected for cleanliness, degree of erosion, etc.

For breakers, which operate very frequently such as those on motor starting and arc furnace switching, more maintenance will be required especially when breaker opens large fault currents as well as ordinary load currents. Until experience has been acquired on such an application, inspection should be scheduled at least every two months or every 2500 operations whichever comes sooner. At inspection, such breakers will need close checking of contact and mechanism wear. Also they may need cleaning in the arc chutes and re-adjustments in the mechanism.

ARC CHUTES

The insulating parts of the arc chute remain in the circuit across the contacts at all times. During the time that the contacts are open, these insulating

parts are subjected to the full potential across the breaker. Ability to withstand this potential depends upon the care given the insulation.

On general inspections blow out the arc chute with dry compressed air by directing the stream upward from the contact area and out through each of the slots between the arc splitter plates. Also direct the dry air stream thoroughly over the arc box shields. These are the ceramic liners in the lower end of the chute where the arc is drawn.

The arc chutes may be removed periodically for a thorough inspection. Remove any residue or dirt or arc products with a cloth or by a light sanding. Do not use a wire brush or emery cloth for this purpose because of the possibility of embedding conducting particles in the ceramic material.

When inspecting an arc chute, look for following:

1. Broken or Cracked Ceramic Parts. Small pieces broken out of ceramics, or small cracks are not important. But large breaks and particularly cracks from the inverted V slot in the interrupter plates out to the edge of the plate or to the top may interfere with proper performance of the interrupter. Hence if more than one or two broken or badly cracked plates are apparent, renewal of the ceramic stack is indicated.

2. Erosion of Ceramics. When an arc strikes the ceramic parts in the arc chute, the surface of the ceramic will be melted slightly. When solidified again, the surface will have a glazed whitish appearance. At low and medium currents, this effect is very slight. However large current arcs repeated many times may boil away appreciable amounts of the ceramic. When the width of the slot at its upper or narrow end (originally $\frac{1}{16}$) has been eroded to twice its original size, (or about $\frac{1}{8}$ inch) the ceramic stack assembly should be replaced.

3. Dirt in Arc Chute. In service the arc chute assembly will become dirty from three causes. First, dust deposited from the air can readily be blown out of the chute with a dry compressed air stream. Second, loose soot deposited on the inside surfaces of the arc chute in the lower portions near the contacts may be removed by wiping with cloths free of grease or metallic particles. Third, some deposits from the arc gasses will adhere very tightly to the ceramic arc shields near the contacts. These deposits from the metal vapors boiled out of the contacts and arc horn, may accumulate to a harmful amount only in breakers which get many operations at low or medium interrupted currents.

Cleaning Arc Shields. Cleaning methods for the first two types of dirt are obvious as mentioned

above. Particular attention should be paid also to any dirt on Micarta surfaces exposed to the arc below the ceramic arc shield. Wipe clean if possible. If wiping will not remove dirt, rub with sand paper and refinish these inside Micarta surfaces with Westinghouse red enamel No. 672 or equivalent. On breakers which get thousands of operations at low and medium interrupted currents, tightly adhering dirt may accumulate on the ceramic arc shields sufficiently to impair proper interrupting performance. This tightly adhering dirt can be removed only by rubbing with coarse sandpaper or other non-conducting abrasive paper. Doing this by hand inside the arc chute is slow and tedious. It is better to remove the ceramic arc shields from the arc chute and clean them with a power buffer or sander.

The ceramic arc shields may appear dirty and yet have sufficient dielectric strength. The following insulation test may be used as a guide in determining when this complete or major cleaning operation is required. 4.16 kv breaker arc chutes should withstand 15 kv, 60 cycles for one minute between front and rear arc horns. 7.2 and 13.8 kv breaker arc chutes should withstand 28 kv. Also the dirty surface of the ceramic near the contacts should withstand approximately 10 kv per inch when test prods are put directly onto the ceramic surface. When test voltage is applied, there should be no luminous display in the black deposits. If, after wiping and a light sanding in place, the ceramic surfaces will not withstand above insulation test, they should be removed and thoroughly cleaned with a power sander. While the ceramic arc shields or fire plates are out of the arc chute, the micarta surfaces behind them should be wiped clean, sanded lightly and refinished with Westinghouse No. 672 enamel.

After an arc chute has been replaced, inspect it to make certain that the contact of the rear arcing horn has engaged the connector on the blowout coil, that the upper edge of the jacket is substantially parallel to the magnetic pole faces, and that the front arcing horn is securely connected to the lower bushing by means of the shunt strap.

CONTACTS

In normal operation the arc will make terminal marks all over the arcing contacts and to a lesser extent on nearby metal parts. High current arcs will erode arc contact material more rapidly, but high current arcs move upward very quickly off the contacts. Low current arcs move very slowly and their terminals may hop around the arcing contacts

for several cycles. Hence a breaker which has had many operations at low currents, may be expected to have numerous small burned spots and pock marks all over the metal parts supporting the arcing contacts. When inspecting arcing contacts the important condition to be observed is the extent of the erosion of the contact material. When half of the original one eighth inch thickness has gone, the contact should be replaced. This is because the remaining $\frac{1}{16}$ inch thickness will be mechanically weak and might be broken away suddenly.

On high fault current operations there may be occasional slight burning on main contacts. Also after many operations, main contacts will sometimes become roughened. A fine flat file should be used lightly on the main contact silvers, removing only enough to take off the high spots. A moderate amount of pitting on the main contact surfaces will not appreciably impair their current-carrying ability because of the high contact pressure.

After contacts have been worn and dressed off as above, contact adjustments should be checked. See discussion on contact adjustment, page 9. Most re-adjusting will involve changing position of nuts at lower end of insulating operating rod to lengthen or shorten rod. Some mechanics may prefer to do this adjusting on the operating rod with the breaker in the closed position. If this is done, the danger in this practice should be understood and safety precautions taken. *The energy stored in the contact and opening springs can very easily lead to severe personal injury if breaker is accidentally tripped while head or hands are near the moving parts. Therefore, a safety block or guard should be put on the breaker to stop the contact arms early in the opening stroke.*

On 4.16 kv breakers, adjustment of the center pole is made in a slightly different manner. On some breakers a special tapped block is used on the lower side of the cross bar instead of a standard nut. Adjustment is made by removing the pin at the upper end of the operating rod, loosening the nut on the upper side of the cross bar, and then turning the operating rod. Tighten upper nut each time adjustment is checked. When satisfactory adjustment is obtained, replace cotter pin at upper end of operating rod. On other breakers, a standard nut is used on the lower end of the operating rod below the cross bar. On these breakers close contacts part way with hand closing lever and insert a wood block under the cross bar to hold it about half way up to the closed position. The locking clips can then be readily opened and the nuts turned with open end wrenches. After satisfactory

adjustment has been obtained remember to reset locking clips.

ORGANIC INSULATION

Organic insulating materials are used in high voltage air circuit breakers for pole unit supports, operating rods, barriers, braces, arc chutes and similar purposes, where it has been found to be more suitable than porcelain. The material used on Westinghouse breakers is Micarta, which has a long established record for insulating and mechanical dependability. To ensure long continued electrical resistance, the Micarta surface is protected with high grade insulating varnish which may be either clear or pigmented, depending on the place of use and the apparatus design requirements.

The purpose of the varnish is to retard moisture absorption and to provide an easily cleaned surface. Like all other insulating surfaces, whether organic or inorganic, a varnished Micarta surface should receive periodic attention in order to maintain the insulation resistance at the highest possible value.

The objects of maintenance are two-fold, first to remove dust and other foreign air borne materials as well as chemical oxides which result from aging of the varnish, and second to make sure that the varnish provides a continuous protective film over the entire insulating surface.

In addition to the usually recommended periodic equipment inspections, on breakers that have been in service for three to five years, the insulation should be inspected, cleaned, and the varnish renewed if the surface indicates it to be needed.

Cleaning. While the surface of the insulation is dry, contamination does not usually cause any large change in insulation value. However, if while it is present, moisture is added in the form of condensation, or by more direct means, the surface electrical leakage may be greatly increased, even to the point of electrical breakdown. The first object of maintenance therefore is cleaning. A clean varnished surface will be smooth, glossy, and free from foreign material either loose or adhering to the surface.

To obtain a clean surface, it is necessary to loosen the adhesive dirt by scrubbing and washing. This is best accomplished in the following manner:

1. Wash with normal heptane, obtainable from the major oil companies such as Esso Standard. Use clean paper towels wet in the heptane. Use a fresh towel on each part.

Caution: Heptane is inflammable and no open flames or sparks should be allowed near the work. Provide ample ventilation. Avoid long continued contact to skin by using neoprene gloves.

Normal heptane is recommended for this use because, (a) it will not harm the varnish, (b) it will quickly vaporize, (c) it will leave no residue which might tend to cause wetting action, and (d) it is practically non-toxic assuming good ventilation. If normal heptane is not available, any substitute should meet all above requirements. Acceptable substitutes are straight petroleum distillates such as mixed heptanes, white or non-leaded gasoline without benzol additives, Westinghouse solvent No. 1609-1, or -2, Stoddard solvent, mineral spirits, and cleaners' naphtha.

2. After the heptane has evaporated, which requires only a minute or two, wash with de-ionized water, sometimes called demineralized water, or distilled water.

Note: De-ionized or demineralized water can be obtained in small quantities from many firms that maintain chemical laboratories, particularly storage battery manufacturers or electroplaters.

Use fresh paper towels and keep the water in a handy size glass bottle. Wet the towel from the bottle, wash the part and dry immediately with a fresh towel. Use fresh towels for each part.

Inspection. When inspecting the insulating parts preparatory to cleaning, wipe off superficial dirt with a dry cloth and note the condition of the varnish and of the Micarta. If the varnish appears in good condition, i.e., fairly smooth and with liberal coverage, proceed with cleaning.

If the varnish appears thin, and is not uniform in coverage, is cracked, or can be peeled off with the fingernail, the parts should be revarnished.

Varnishing. Varnishing can be done with the parts in position on the breaker, as follows:

1. Sandpaper when needed to remove loose varnish and wipe off all dust from sanding.

2. Apply three coats of varnish, Westinghouse M# 135-2. Allow 24 hours drying time between coats at ordinary temperatures. Drying time may be decreased by preheating parts with infrared lamps to a temperature of 40 to 50 degrees C before applying varnish and likewise heating each coat for about 4 to 8 hours, or until the varnish has set up to the point where it will not be lifted by applying the succeeding coat.

Laminated Insulation. Resin bonded laminated insulating materials are formed under pressure at high temperature. The release of pressure, reduction of temperature and some further shrinking of the resin bond produces internal stresses. Relieving of these stresses may result in the formation of minute cracks or checks along the laminated edges of the insulation. Such cracks, if small, are sealed by the varnish and are not harmful.

OPERATING MECHANISM

With average conditions, the breaker operating mechanism may be expected to operate 5000 times or more with only routine inspection and lubrication. During inspection the following points should be kept in mind. Remove loose dust and dirt with a compressed air stream. Wipe off latch and roller surfaces. With hand closing lever, move mechanism parts slowly closed to point where arcing contacts just touch, and then allow contact arms to fall slowly to open position, observing for any evidence of stickiness or excessive friction. Holding trigger up, move hand closing lever up and down slowly. The core should move freely in the solenoid and the linkage system should reset positively when weight of hand close lever is removed slowly.

Lubrication. If any excessive friction or binding is discovered on above inspection, relieve it either by adding oil or if necessary by cleaning old dried lubricant from bearing surfaces. In general, the addition of a few drops of oil should be sufficient in most cases. In a few cases, after long service, the accumulation of dried or oxidized lubricant may make it necessary to disassemble parts and clean them. Carbon tetrachloride is a good solvent for this.

Apply a small amount of a light oil to the wearing surfaces. Use a stable oil with a low rate of oxidation and with a low pour point. Wemco C is suggested. Avoid putting oil on insulating material surfaces. Also put no oil on the breaker contacts, nor on the auxiliary switch. Soft petrolatum may be used on the drawout connectors both primary and secondary. For the puffer pistons a few drops of Wemco C is recommended. Place the oil on cylinder walls, and spread around by operating a few times. For the air bumper, which has a bronze piston and rings in a brass cylinder, a small amount of graphite grease (W) 1022-1 is recommended. In dusty, dirty locations, surplus oil may catch and hold grit near bearings and latches and cause faster wear. In such locations, it is recommended that oil be omitted, and the steel parts in the mechanism be lubricated by rubbing with (W) Molkolube powder (# 8565-3).

MAINTENANCE

Clearances. After a mechanism has operated several thousand times, the following points should be checked as part of routine inspection. With breaker open and mechanism reset there should be $\frac{1}{32}$ to $\frac{1}{16}$ clearance from tripping latch roller to cam. If re-adjustment is necessary, see explanation under mechanism adjustments. To permit the closing latch to move up to its holding position the roller at the lower end of the non trip free lever must overtravel the latch surface slightly. With breaker closed, look thru the slot in panel with a flashlight at the closing latch and roller, and energize the close coil for one or two seconds several times.

The overtravel should be approximately $\frac{1}{32}$ minimum to $\frac{3}{32}$ maximum. With wear in the link holes and pins, this overtravel may decrease. Adjustment is made with steel shim washers between the magnet back plate and the four large magnetic return studs.

After about 15,000 operations, replacement of some parts may be required. During routine maintenance, the amount of wear should be observed on latch surfaces, rollers, pins and pin holes. If it becomes impossible to obtain correct adjustments or if latches fail to hold, replacements should be considered.

Renewal Parts. A list of renewal parts recommended to be kept in stock will be furnished upon request. When ordering renewal parts, specify the name of the part, and include all of the information given on the breaker nameplate.

WESTINGHOUSE													
METAL CLAD SWITCHGEAR													
DE-ION AIR CIRCUIT BREAKER DH													
STYLE OR SO		DATE OF MANUFACTURE											
SERIAL		BREAKER UNIT & CODE											
RATED KV		WILL FIT HOUSING CODE											
MAX DESIGN KV		TYPE MECHANISM											
AMPERES		CLOSING VOLTAGE											
CYCLES		TRIPPING VOLTAGE											
<table border="0"> <tr> <td style="padding-right: 10px;">PATENTS</td> <td style="padding-right: 10px;">2442199</td> <td style="padding-right: 10px;">2276968</td> <td style="padding-right: 10px;">2243040</td> <td style="padding-right: 10px;">2243038</td> </tr> <tr> <td></td> <td>2242905</td> <td>2177014</td> <td>2039054</td> <td>2029589</td> </tr> </table>				PATENTS	2442199	2276968	2243040	2243038		2242905	2177014	2039054	2029589
PATENTS	2442199	2276968	2243040	2243038									
	2242905	2177014	2039054	2029589									
<table border="0"> <tr> <td style="padding-right: 10px;">•</td> <td style="padding-right: 10px;">WESTINGHOUSE ELECTRIC CORP.</td> <td style="padding-right: 10px;">•</td> </tr> <tr> <td style="padding-right: 10px;">NP54068 B</td> <td style="padding-right: 10px;">MADE IN U.S.A.</td> <td style="padding-right: 10px;">•</td> </tr> </table>				•	WESTINGHOUSE ELECTRIC CORP.	•	NP54068 B	MADE IN U.S.A.	•				
•	WESTINGHOUSE ELECTRIC CORP.	•											
NP54068 B	MADE IN U.S.A.	•											

www.ElectricalPartManuals.com

www.ElectricalPartManuals.com



DESCRIPTION • INSTALLATION • MAINTENANCE

INSTRUCTIONS

Main Sub Station

METAL-CLAD SWITCHGEAR

with

Type "DH"
Air Circuit Breakers

WESTINGHOUSE ELECTRIC CORPORATION
SWITCHGEAR DIVISION

EAST PITTSBURGH PLANT

•

EAST PITTSBURGH, PA.

TABLE OF CONTENTS

Part One	DESCRIPTION	Pages 9-15
	Housing	9
	Main Disconnecting Contacts	10
	Secondary Disconnecting Contacts	10
	Shutter	11
	Disconnecting Type Potential Transformers	12
	Removable Breaker Element	13
	Handling Dolly	14
	Transport Truck	14
	Accessories	14
Part Two	RECEIVING, HANDLING AND STORING	Pages 16-18
	Receiving	16
	Handling Facilities	16
	Storing	17
	Indoor Switchgear	17
	Outdoor Switchgear	18
	Control Storage Batteries	18
Part Three	INSTALLATION	Pages 19-34
	Foundation or Floor	19
	Indoor Switchgear	19
	Outdoor Switchgear	20
	Weight of Units	19
	Conduit Layout and Switchgear Floor Plan	20
	Installation of Housings	21
	Indoor Housings	21
	Outdoor Housings	24
	Power Transformer Connections	24
	Bus Run Type	24
	Box Enclosure Type	26
	Close Coupled Type	26
	Control Conduit	26
	Installation of Bus Connections	27
	Taping	28
	Main Power Connections	28
	Potheads	29
	Solderless Connectors	29
	Flexible Connectors	29
	General	30
	Addition of Units to Existing Assembly	30

Part Three	INSTALLATION (Continued)	Pages 19-34
Ground Bus Connections		31
Plate Ground		31
Pipe Ground		31
Secondary and Control Connections		32
Voltage Drop		32
Loading Check		32
Disconnecting Type Potential Transformers		32
Test Cabinet		33
Preparing Breakers for Service		33
Key Interlocks		34
Adjusting and Testing		34
Part Four	OPERATION	Pages 35-40
Placing Breaker Unit in Housing		35
Mechanical Interlock		37
Electrical Operation		37
General		37
Breaker Closing Schemes		39
D-C Control		39
A-C Control		39
Breaker Tripping Schemes		39
Protective Relays		40
Part Five	INSPECTION AND MAINTENANCE	Pages 41-45
Safety Precautions		41
Access to Switchgear Parts		41
Control Equipment		41
High Voltage Parts		41
Potential Transformers		42
Breaker Contacts		42
Maintenance Schedule		42
Buses and Connections		43
Primary and Secondary Disconnecting Contacts		43
Levering Device and Shutter		44
Control Relays		44
Instruments, Relays and other Panel Mounted Devices		44
Dust Filters		44
Secondary Wiring		44
Battery and Charging Equipment		44
Records		44
Abnormal Conditions		45
Lubrication		45
Renewal Parts		45
Recommended Stock of Renewal Parts		45
Instructions for Ordering		45

LIST OF ILLUSTRATIONS

Figure	Page
1 Front View of Typical Indoor Metal-Clad Switchgear Housing	8
2 Instrument Panel Side of Typical Outdoor Metal-Clad Housing	10
3 Breaker Drawout Side of Outdoor Housing	10
4 Breaker Main Disconnecting Contacts	11
5 Sectional View of Main Contacts in Connected Position	11
6 Secondary Disconnecting Contacts	11
7 Automatic Shutter Operating Sequence	12
8a Potential Transformers in Operating Position	12
8b Potential Transformers in Disconnected Position	12
9 Typical Removable Breaker Element	13
10 Indoor Handling Dolly	14
11 Outdoor Transport Truck	14
12a Typical Shipping Group of Indoor Housings	16
12b Removal of Skids by Jacking	16
13 Typical Shipping Group of Outdoor Housings	17
14 Suggested Methods of Installing Steel Channels in Floor	20
15 Typical Base Plan for Outdoor Metal-Clad Switchgear	21
16 Typical Floor Plan for Indoor Metal-Clad Switchgear	22
17 Assembly of Typical Indoor Metal-Clad Switchgear	23
18 Leveling the Units with Shims	24
19 Adjusting Rail Tips	24
20 Shop and Field Assembly—Outdoor	25
21 Bus Run Throat Connection to Transformer	26
22 Typical Front Views of Close-Coupled Indoor Unit Substations	26
23 Connections to Transformer	27
24 Plan View of Typical Main Bus Installation	27
25 Detail of Bolted Joint	28
26 Installation of Compound Box	28
27 Taping Instructions	29
28 Typical Main Cable Installations	30
29 Plan View and Details of Typical Ground Bus Installation	31
30 Disconnecting Type Potential Transformers in Shipping Position	32
31 Test Control Cabinet	33
32 Engaging Secondary Contacts with Breaker in "Test Position"	35
33 Placing Breaker in the Housing	36
34 Breaker Mechanical Interlock	37
35 Basic Circuit Breaker Control Schemes	38
36 Removing Rear Barrier to Main Cable Connections	41
37 Removing Barrier to Main Bus Compartment	42
38 Access to Potential Transformers	42
39 Removing Interphase Barrier	43
40 Removing Arc Chutes	43
41 15 KV Type "DH" Breaker (one barrier and arc chute removed)	44
42 Facsimile of Housing Nameplate	45

IMPORTANT

Metal-clad switchgear is strongly built and provided with many safety features. Nevertheless, it controls high voltage circuits which are dangerous and the equipment contains many delicate devices. The following summarizes recommended *PRECAUTIONS* in handling, installing, and operating metal-clad switchgear:

1. Only authorized personnel should be permitted to handle or operate the switchgear.
2. Handle all switchgear (even if crated) with extreme care as it contains delicate instruments and relays which may be damaged by rough handling.
3. When uncrating switchgear, exercise care not to scratch or mar the panel finish.
4. Remove blocking of relay armatures and check control circuits (except potential and current transformer circuits) for grounds and short circuits before applying control power (Refer to "Loading Check" page 32).
5. Check proper phasing of all circuits and connect the switchgear to the station ground before applying high voltage power.
6. Do not work around "live" parts. The compartments of metal-clad switchgear are arranged so that, if a circuit has been de-energized, the compartment enclosing that circuit may be opened for maintenance without exposing any other circuit.
7. Never bring an exposed flame near the storage battery since the gasses given off during charging may form an explosive mixture.
8. In case of fire do not use liquid fire extinguishers until all circuits have been made electrically "dead".
9. An ounce of prevention is worth a pound of cure. All personnel responsible for supervision and operation should be familiar with the switchgear and its functions. In time of emergency there is seldom time to consult the instruction material.
10. **Caution.** *If outdoor switchgear is to be stored prior to installation, provision must be made for energizing the space heaters to prevent condensation of moisture inside the switchgear.*
11. **Caution.** *If indoor switchgear is to be stored prior to installation, it must be protected from the weather and be kept free of condensation. Whenever possible store the indoor switchgear where it will not be exposed to sunlight or sustained temperatures of 120°F. and higher. If the switchgear has been so exposed, the strippable plastic coating supplied on the front panels must be removed within 30 days.*

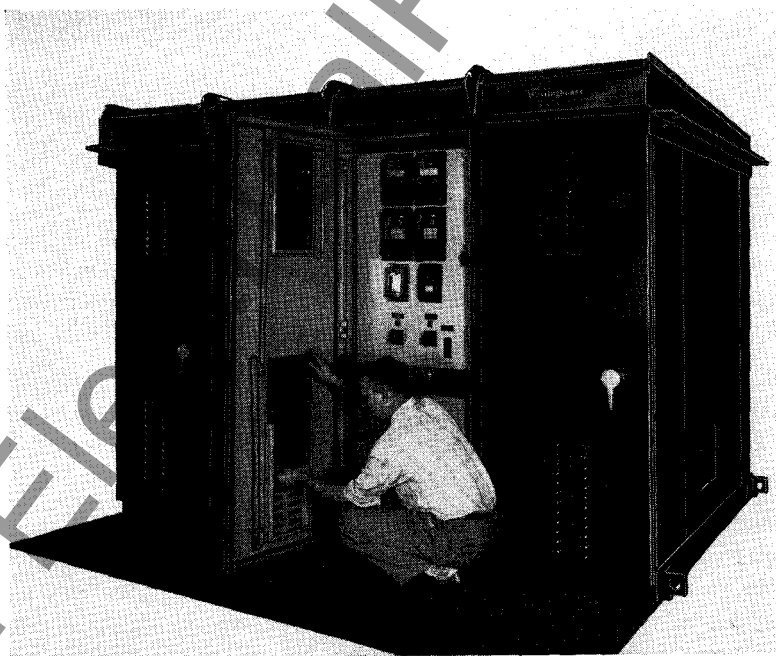
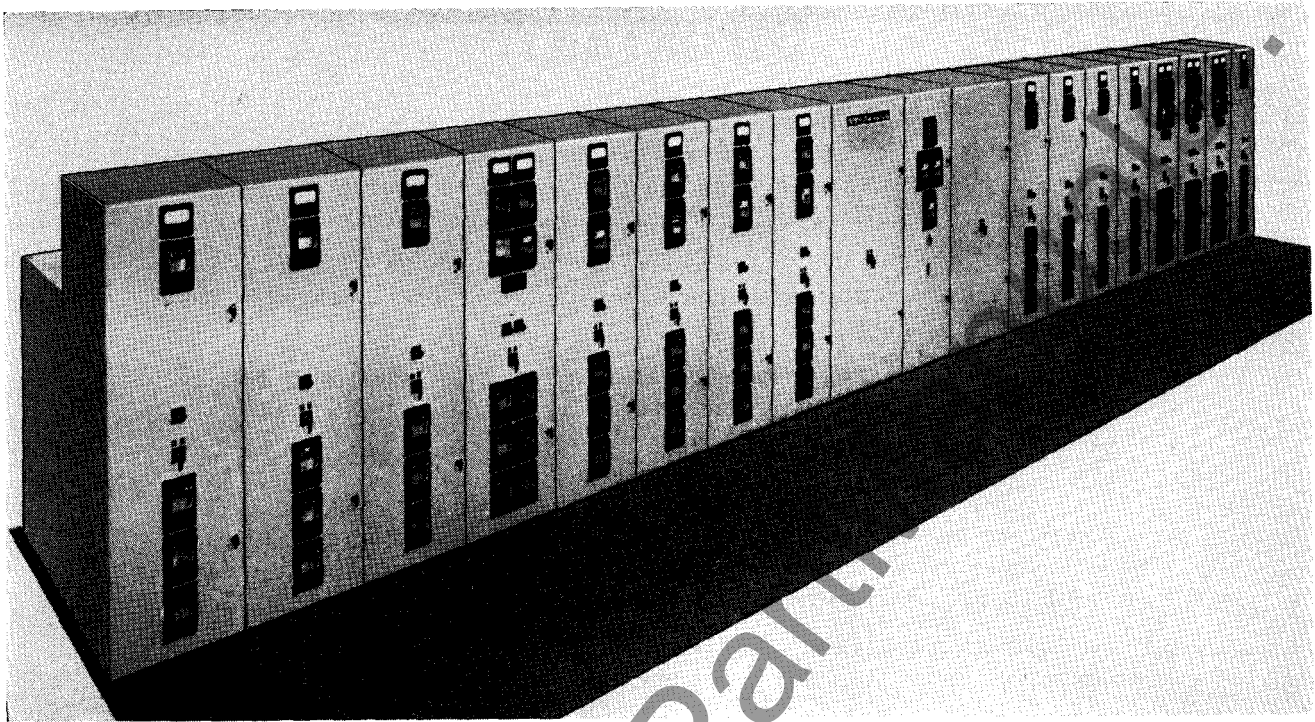

High-Voltage METAL-CLAD SWITCHGEAR

This instruction book has been prepared to familiarize the Purchaser's engineering, installation and operating staffs with the metal-clad switchgear supplied by Westinghouse for this assembly. Personnel responsible for supervision, operation or maintenance should become well acquainted with the appearance and characteristics of each piece of equipment contained in or mounted on the switchgear.

The following descriptions apply to the standard metal-clad construction and wiring. Extra features and special control schemes are often incorporated when specified by the Purchaser's order. These special features are evident on the drawings and connection diagrams for the switchgear assembly. Instructions on standard apparatus such as relays, instruments and circuit breakers are included as required in the instruction book for a particular metal-clad assembly.

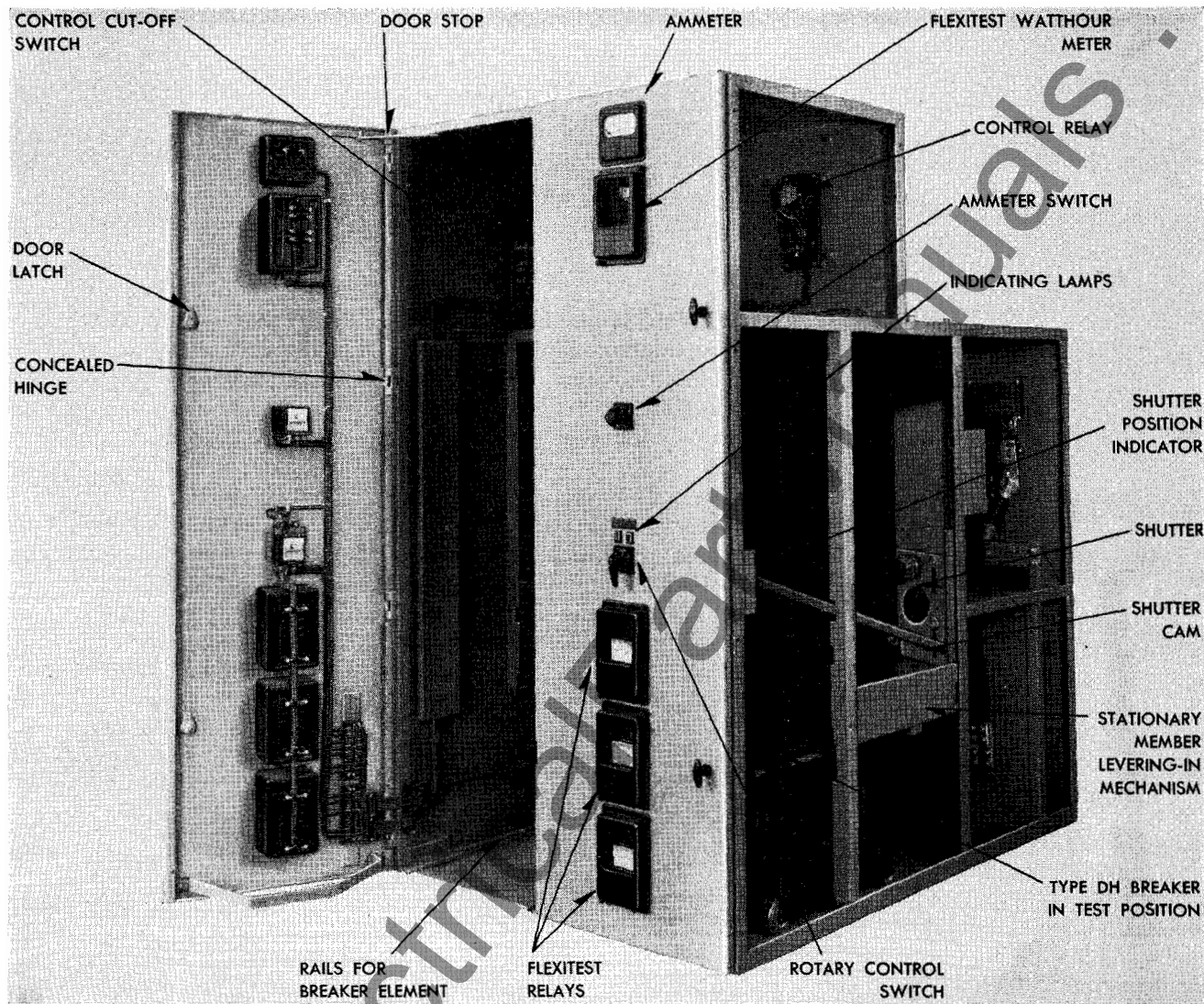

FIG. 1. Front View of Typical Indoor Metal-Clad Switchgear Housing

DESCRIPTION

Metal-Clad switchgear is designed to accomplish the control of high voltage circuits. The necessary circuit breakers, busses, current transformers, potential transformers, protective relays and secondary control devices are all included in one metal-clad assembly. This assembly, in general, is composed of standard sub-assemblies or units arranged to provide the structure required by the Purchaser's order.

The general assembly and section drawings which are made for each switchgear installation present a picture of the complete assembly of component equipment. The designations of the circuits controlled, the voltage and current rating of the bus and circuit breakers and a simplified one-line diagram of the main connections are all normally included on these drawings.

Each metal-clad unit consists of a stationary housing and a removable breaker element. The housing supports the instrument panel and contains the busses, instrument transformers and circuit connections. The breaker element consists of a type "DH" air circuit breaker mounted on a wheeled frame.

Metal-clad switchgear is designed to provide maximum safety to the operator. During normal service there is no danger of accidental contact with high-tension line parts because all high-tension equipment and connections are enclosed in grounded, metal compartments. The removable feature of the breaker element affords the same protection as air break switches in isolating the circuit controlled.

Access to the control wiring and secondary connection compartments is provided by hinged doors or panels. These panels may be opened safely when the units are in service because steel barriers isolate these connection compartments from the high-tension circuits. Access to the high-tension compartments enclosing current transformers, busses and connections, is provided by removable bolted-on covers. These covers should not be removed unless the circuits to be exposed are de-energized. Potential transformers provided with metal-clad switchgear are of the disconnecting type which insures that the primaries are disconnected and grounded before the fuses are accessible.

A mechanical interlock on the levering device prevents moving the breaker into or out of the operating position unless the breaker is tripped. Other safety features such as key interlocks, locked panels, and electrical interlocking of control circuits are provided when specially ordered.

For outdoor use the switchgear is designed with a weather-proof housing, special under-frame or base, and with access doors at both front and rear of the unit. Also for outdoor use, space heaters and special ventilators are provided in each unit to reduce the possibility of condensation.

The following paragraphs describe in further detail the principal parts and features of the metal-clad switchgear construction.

HOUSING

The housings are made of structural steel members and hot rolled stretcher-levelled steel sheets, securely welded together to form rigid, self-supporting, completely enclosed units with metal barriers between the different compartments. The housings are assembled in jigs which insure that all units will be uniform and accurate in size.

The front of the switchgear assembly is generally considered to be the instrument panel side of the switchgear. Fig. 1 shows the front view of typical indoor metal-clad switchgear housings. The removable breaker element is withdrawn on the instrument panel side for the standard indoor construction and on the side opposite the instrument panel for the outdoor construction. For special designs, the front instrument panel and breaker drawout sides are as marked on the general assembly and section drawings. A metal barrier isolates all high tension parts of the breaker from the enclosing panel on the breaker drawout side so that the control wiring and breaker mechanism may be inspected without exposing any high tension parts.

The outdoor weatherproof housings are constructed of framed sections of hot rolled stretcher-levelled steel. Weatherproof hinged doors are provided at both the instrument panel and breaker drawout sides. Typical views of the instrument panel and breaker drawout sides of outdoor switchgear are shown in Figs. 2 and 3. These

DESCRIPTION

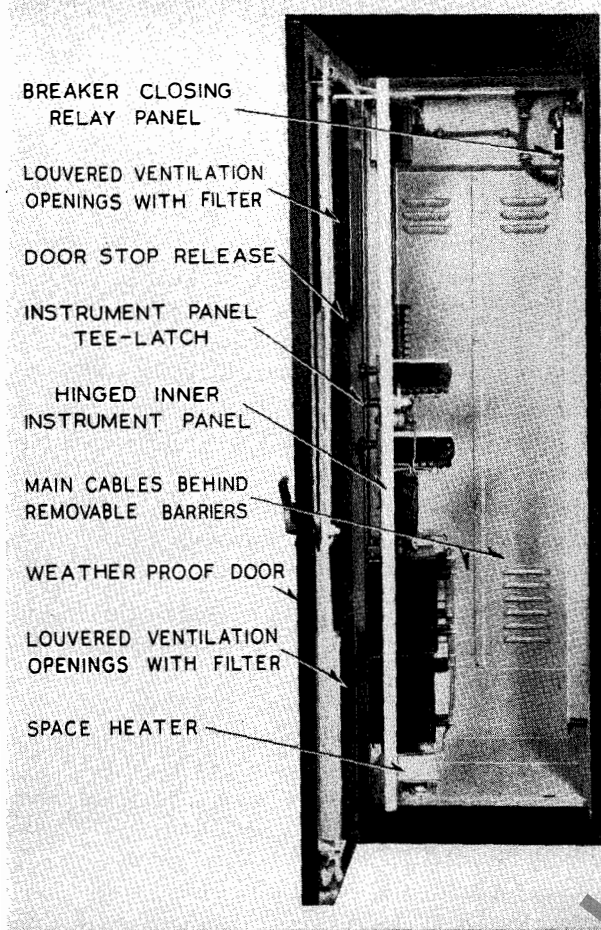

FIG. 2. Instrument Panel Side of Typical Outdoor Metal-Clad Housing

doors are equipped with latch type stops that hold them in the full open position which permits the instrument panel to be opened approximately 90°.

Adjacent housings for both indoor and outdoor designs are separated by a single common steel barrier. This barrier is the left side sheet of the unit when viewed from the breaker drawout side. A special set of removable enclosing covers is supplied on the right end of the assembly as viewed from breaker side. When, and if, additional units are added on this end of the assembly these special end covers must be removed and placed on the new unit.

MAIN DISCONNECTING CONTACTS

The main disconnecting contacts (Fig. 5) are located in horizontal Moldarta or porcelain tubes mounted behind the barrier between the breaker and bus compartments.

The contact consists of a silver plated stud mounted in the tube on the stationary housing and a number of silver plated segments assembled on

the circuit breaker bushing. The segments are arranged in a circle with contact pressure exerted by flat springs held in a collar around the finger assembly. In the engaged position, the fingers form a bridging contact between the circuit breaker stud and the stationary contact studs as shown in the cross section view of Fig. 5. This permits considerable flexibility in alignment without the use of flexible shunts.

The stationary contact mounting tubes are mounted in jig drilled mounting plates, accurately located in the housing and can be removed and replaced if necessary for contact maintenance without disturbing the alignment. A special tool is supplied with the equipment for removing and replacing the stationary stud.

SECONDARY DISCONNECTING CONTACTS

Secondary disconnecting contacts provide connections for the control leads between the removable breaker element and the stationary housings. These consist of multiple plug and socket contacts (Fig. 6) of the train-line-coupler type. Each individual contact consists of a round 4-

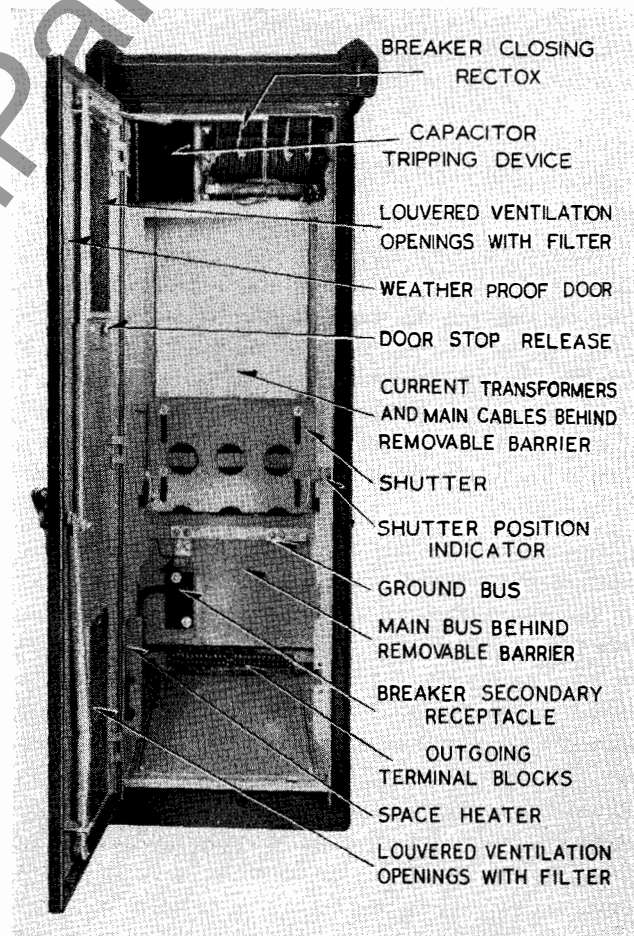

FIG. 3. Breaker Drawout Side of Outdoor Housing

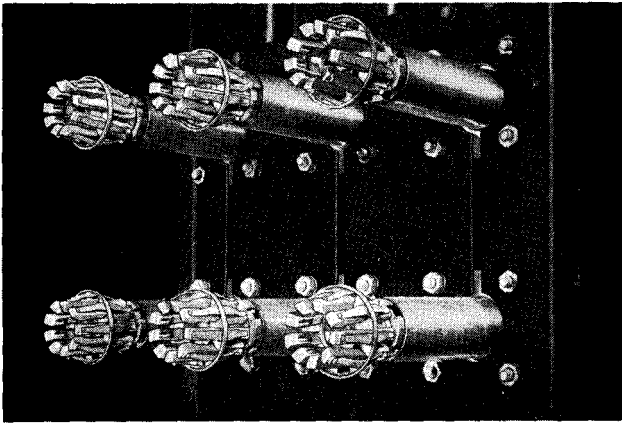

FIG. 4. Breaker Main Disconnecting Contacts

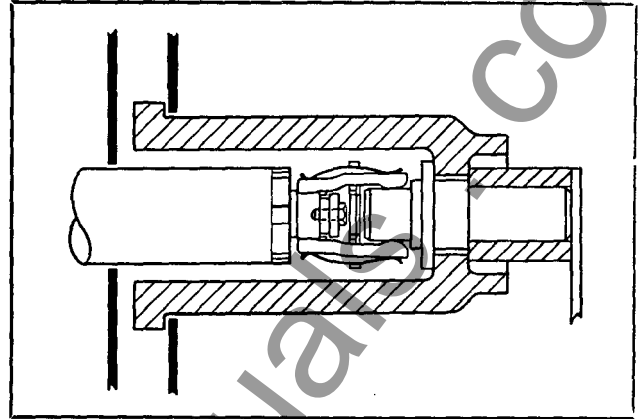

FIG. 5. Sectional View of Main Contacts in Connected Position

segment silver plated pin fitting into a silver plated copper tube. The pins and tubes are molded into Moldarta blocks to form the plug and socket assemblies. These molded assemblies are mechanically strong and provide a moisture resistant insulation of high quality. The secondary wiring is connected by soldering the wire in holes drilled in the connection end of the pin and tube contacts.

The plug half of the assembled contact is mounted on a sliding bracket assembly on the breaker unit while the socket half is bolted to the housing. These secondary contacts engage automatically when the breaker unit is inserted to the operating position. The guide pins are of different sizes so as to polarize the contacts. The socket half is flexibly mounted with oversize holes on a shoulder bolt so that the contacts will be self aligning. With the breaker in the test position the secondary contacts may be engaged for testing by releasing a catch lever and firmly pushing the sliding mounting bracket to the rear.

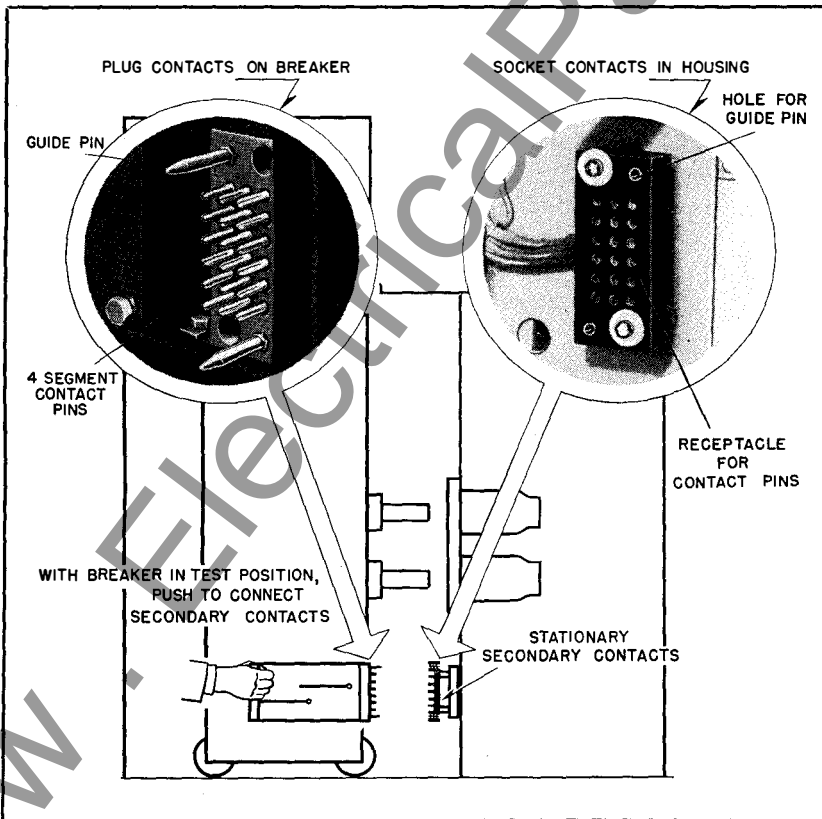

FIG. 6. Secondary Disconnecting Contacts
Contacts may be engaged with breaker in test position by releasing catch and pushing slide mounting on the breaker.

SHUTTER

The shutter is an automatically operated movable metal barrier which covers the stationary main contact mounting tubes when the breaker is removed from the housing.

The shutter and its operation are shown in Figs. 3 and 7. The shutter is a part of the stationary housing and is raised by a roller on the breaker operating against the cam surface of the shutter arm when the breaker is levered into the operating position. When the breaker is removed, the shutter drops by gravity as the roller clears the cam surface. When the shutter is fully closed, it provides a metal barrier between the breaker and the stationary main contacts which may be electrically "alive".

DESCRIPTION

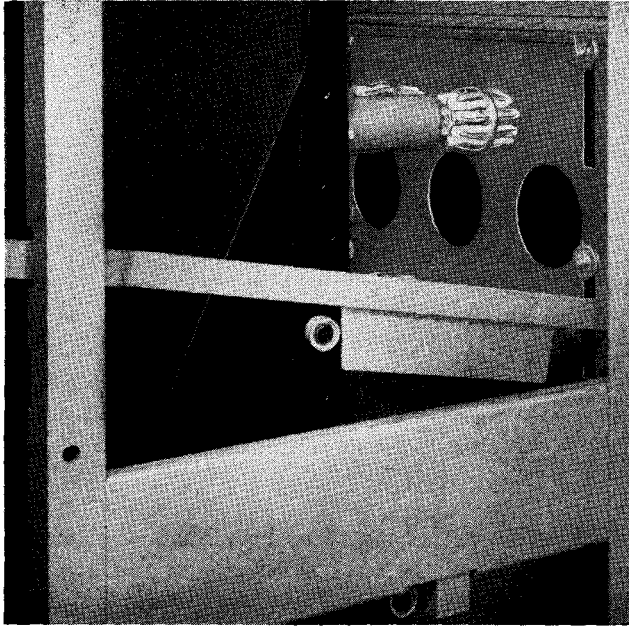

Shutter closed—breaker roller engaging cam, about to raise shutter

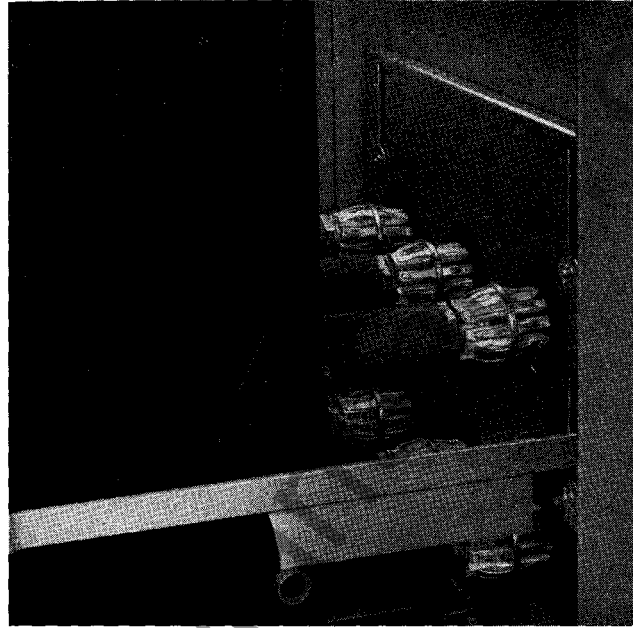

Shutter opening—stationary contacts almost cleared for entry of breaker contacts

FIG. 7. Automatic Shutter Operating Sequence (Figure 3 on page 10 shows shutter fully closed)

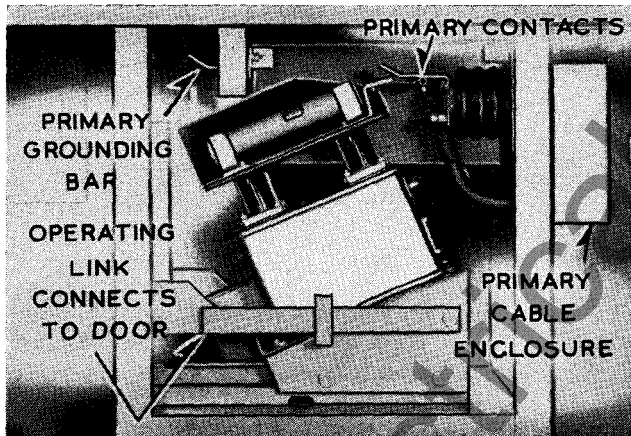

FIG. 8a. Potential Transformers in Operating Position.

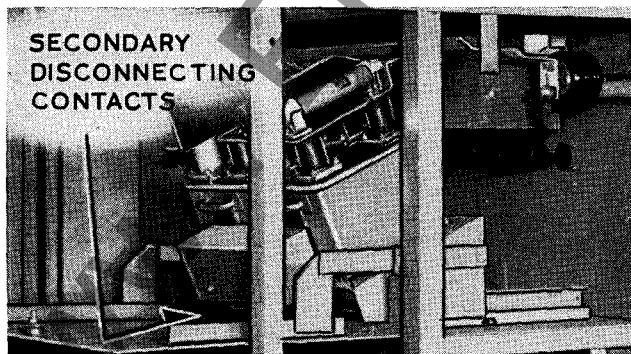

FIG. 8b. Potential Transformers in Disconnected Position

DISCONNECTING TYPE POTENTIAL TRANSFORMERS

The potential transformers supplied in metal-clad switchgear are arranged on a disconnecting type of mounting which is designed to provide maximum safety for the inspection and replacement of the primary fuses. The transformers are mounted on movable drawers which are equipped with contacts for the primary connections and for grounding the movable element. The drawer is so arranged that it will be withdrawn to a safe distance with connections grounded before the fuses are accessible, as shown in Fig. 8b.

This disconnecting type potential transformer compartment is provided with a door which is hinged at the bottom and provided with a "T" handle latch at the top. A set of operating links, with one end attached to the door and the opposite end attached to the movable drawer, retracts the drawer to the disconnected position as the door is opened. Door stops located on each side of the compartment limit the opening of the door to approximately 90°. In this position the primary circuits are disconnected, separated a safe distance from all live parts, and grounded. The secondary connections are made with a sliding contact block assembly located underneath the front part of the drawer. The secondary contacts are disconnected when the compartment door is opened.

REMOVABLE BREAKER ELEMENT

The removable circuit breaker elements are Type DH "De-ion" air circuit breakers, assembled directly on the removable frames. A typical removable element is shown in Fig. 9. Additional description of the breakers supplied with any par-

ticular metal-clad assembly will be found in the breaker instruction book.

The circuit breaker element is moved between the operating and test positions by a worm and gear levering device operated by means of a removable hand crank. The circuit breaker mechanism is interlocked with the levering shaft so that a

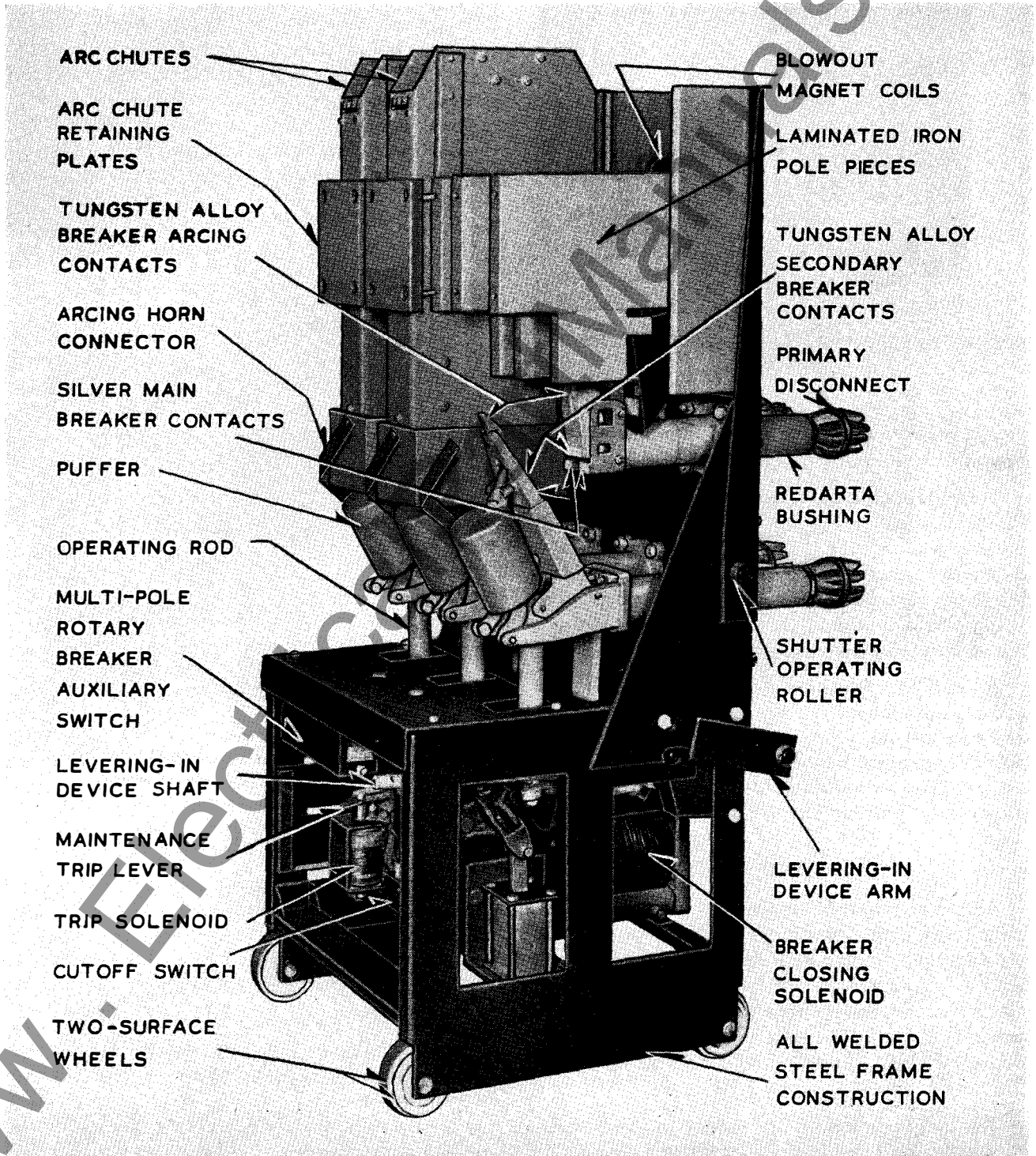

FIG. 9. Typical Removable Breaker Element (Type 50-DH-250) with Barrier and One Arc Chute Removed.

DESCRIPTION

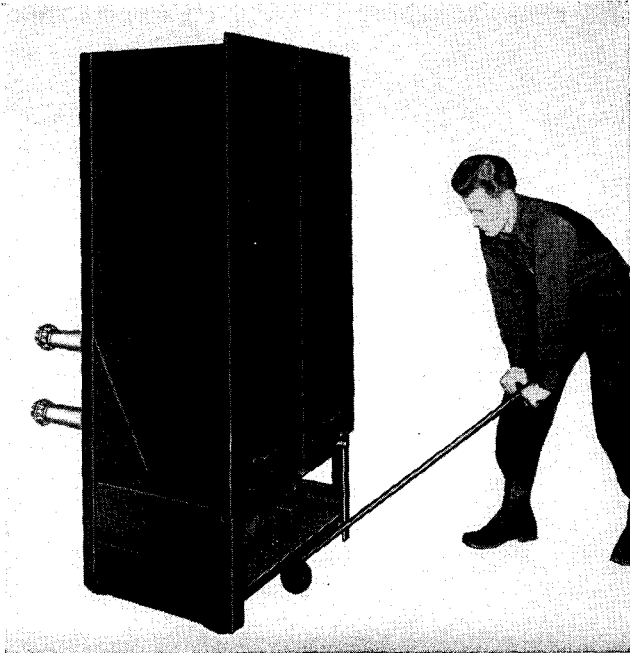

FIG. 10. Handling Dolly Being Used to Move a 150-DH-250 Breaker

closed breaker cannot be moved into or out of the operating position.

This interlock is released in the "disconnect" or "test" position to permit operating the circuit breaker and checking control and interlock connections without energizing the main circuits. The interlock also prevents the circuit breaker from being closed in any intermediate position between the operating and disconnected positions.

All ratings of breakers are equipped with wheels to facilitate moving the breakers into the housing and to allow the breakers to be moved about outside the metal-clad housing. The light duty breakers have two swivel wheels to permit turning. The heavy duty breakers have all wheels fixed.

HANDLING DOLLY

A handling dolly is supplied on orders for indoor switchgear with heavy duty breakers to facilitate turning the removable element when moving it outside the housing. This handling dolly (Fig. 10) consists of two wheels, a handle, and an arm which engages in a hole in the front cross member of the breaker frame. Lowering the handle raises the front of the breaker to permit turning.

The dolly is intended for use when the breaker is outside the housing and should not be used to insert or remove the breaker from the housing.

TRANSPORT TRUCK

To facilitate handling the breaker elements with outdoor switchgear assemblies, a transport truck (Fig. 11) is supplied. The transport truck has two fixed and two swivel wheels which aid in aligning the rail extension guides on the truck with the stationary structure rails. The transport truck is approximately the same height as the switchgear base but can be adjusted plus or minus $\frac{1}{2}$ inch to compensate for variations in the Purchaser's concrete pad. The transport truck is securely clamped to the stationary structure during the inserting or removal operation of the breaker element. The breaker element is securely hooked to the transport truck during movement external to the stationary structure.

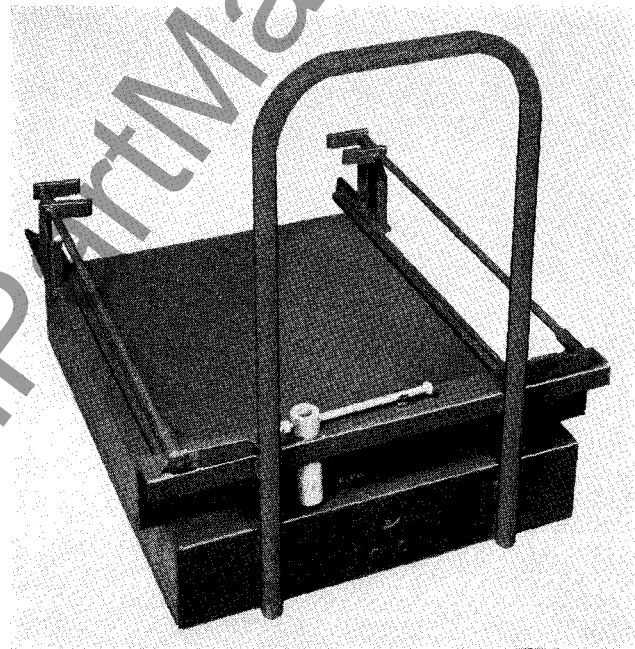

FIG. 11. Outdoor Transport Truck

ACCESSORIES

In addition to the handling dolly and transport truck previously described, each new switchgear installation is normally provided with a set of accessories. Depending upon the nature of the installation these accessories will consist of one or more of the following items:

1. Maintenance operating handle for the circuit breakers. As its name implies, this handle is to be used for operating the breaker mechanism when the breaker has been removed from the switchgear unit to permit observation of the various mechanical linkages and to determine if the proper clearances

and adjustments are maintained. NEVER USE THIS HANDLE TO CLOSE THE BREAKER WHEN THE BREAKER IS IN THE SWITCHGEAR.

2. Levering crank for moving the circuit breaker from test to operate position.

3. Special wrench or pliers for removing stationary portion of breaker disconnecting contacts.

4. One set of test plugs for use with Flexitest relays and meters if such meters and relays are included as part of the switchgear assembly.

5. Test cable for use with outdoor switchgear assemblies to connect breaker control circuits to the switchgear when testing the circuit breaker outside of the switchgear unit.

6. Test cabinet supplied with indoor switchgear assemblies for use in testing the circuit breakers when they are removed from the switchgear units. This test cabinet includes the necessary test cable for connecting control power to the circuit breaker control circuits.

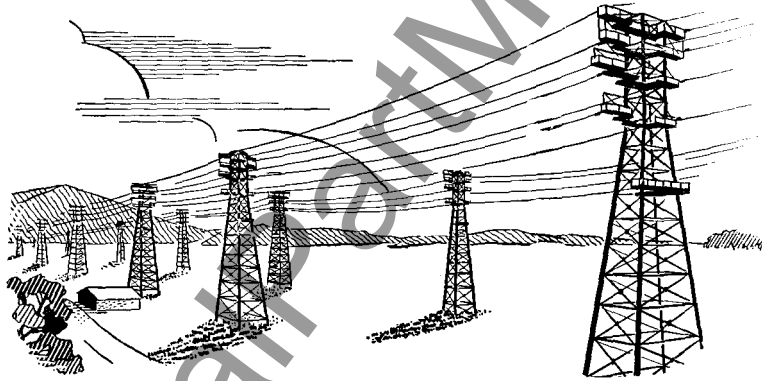

PART TWO

RECEIVING, HANDLING AND STORING

The stationary steel housings of metal-clad switchgear are shipped as complete units, or groups of units, bolted together. Indoor metal-clad switchgear assemblies are shipped in crates for protection against weather. Normally the shipping groups consist of as many units as can be handled and shipped together, unless the Purchaser has specified smaller groups. The breaker elements and accessories are packed and crated separately from the housings.

RECEIVING

When the switchgear reaches its destination, the Purchaser should check the material actually received against the shipping lists to be sure that all parts have been received. This will avoid delays in installation. If damage is found or suspected, file claims as soon as possible with the transportation company and notify the nearest representative of the Westinghouse Electric Corporation.

If the metal-clad switchgear is to be installed as soon as received, it is recommended that the unpacking be done as required for the installation as outlined under the paragraphs which follow. If the switchgear is to be stored or held for some time

before installing, it is advisable to unpack the shipment sufficiently to check the shipment for completeness and condition.

HANDLING FACILITIES

Each shipping group of housings is equipped with a lifting angle or frame for handling by a crane. Figs. 12a and 12b shows a typical shipping group of 5 kv indoor housings with its lifting angle. A balancing chain can be added as shown by dotted lines in Fig. 12a, if desired, as the single lifting angle is located slightly forward of the center of gravity of the units. On the larger 7.5 kv and 15 kv units, a lifting frame is used which consists of two angles and necessary braces.

Indoor switchgear groups are provided with a dual purpose bracing angle at each end of the shipping group. During shipment these heavy angles are used for cross bracing to the freight car. During installation they can be removed and bolted in the lower set of tie bolt holes (as shown in Fig. 12b) to make a handy lifting angle for jacks while removing the skids and lowering the group to the floor.

Fig. 13 shows a group of outdoor housings. It is preferable to handle the housings by a crane, but if a crane is not available the groups can be skidded into place with rollers made from conduit or pipe. Timbers should be placed between switchgear and rollers to protect the equipment.

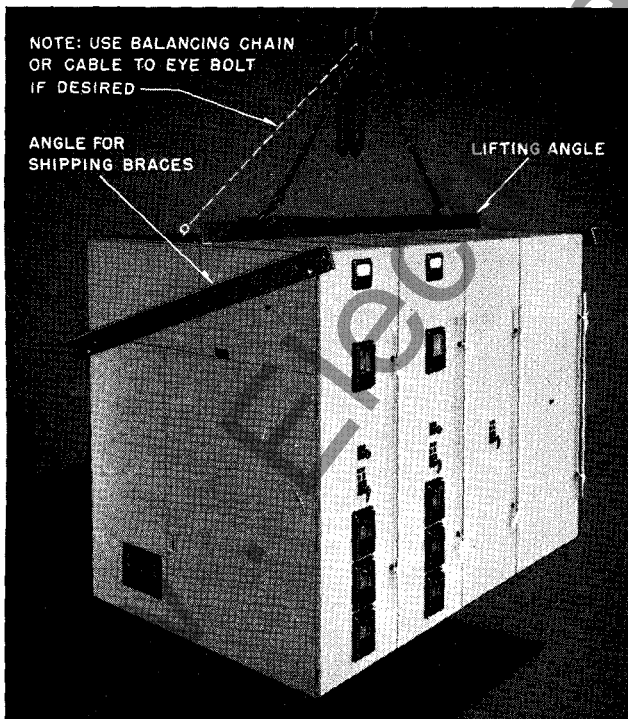

FIG. 12a. Typical Shipping Group of Indoor Housings

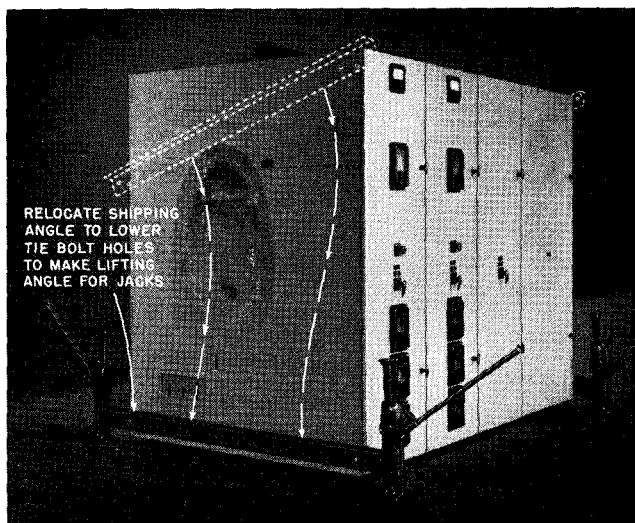

FIG. 12b. Use of Jacks to Lift Group of Units

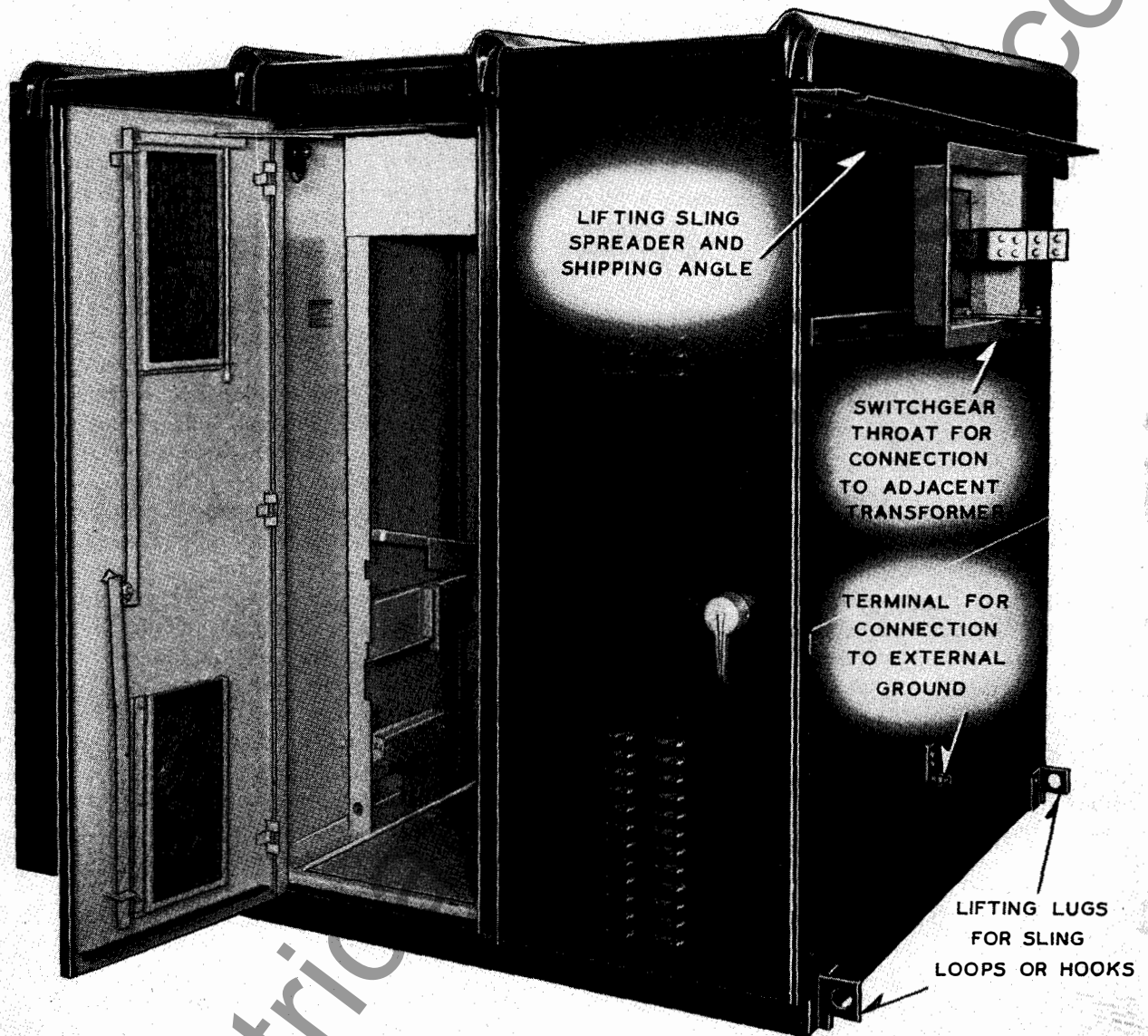

FIG. 13. Typical Shipping Group of Outdoor Housings

STORING

Switchgear which is not or cannot be installed immediately should be stored in a dry, clean place. Trouble and delay will be avoided by having good storage facilities arranged so that the apparatus will be accessible only to authorized persons and so that it can be quickly located when required in the erection program. Crated apparatus will store much better if left crated; however, it should be inspected to make sure that no damage has been incurred during transit. Conditions such as dampness, changes in temperature, cement dust, and corrosive atmosphere, should be carefully guarded against. The longer the period of storage, the

greater must be the care taken for protection of the equipment.

Indoor Switchgear. It is preferable to store indoor metal-clad switchgear indoors in a heated building. If this is impossible, some special precautions should be taken to keep the equipment warm enough to prevent condensation until it is placed in service. Where necessary install temporary heating equipment in switchgear. The equipment should be kept covered and dry and located in such a place as to prevent exposure to sunlight or temperatures above 120°F. During storage the steel housings should be placed on as level a surface as possible to prevent unnecessary strain and possible distortion. If indoor switchgear has been ex-

RECEIVING, HANDLING AND STORING

posed to sunlight or to sustained temperatures of 120°F. and higher, the strippable panel coating **MUST BE REMOVED WITHIN 30 DAYS**. If equipment is stored or located in a cool and dark location, strip off the plastic coating within 18 months.

Outdoor Switchgear. If outdoor metal-clad switchgear is received before installation is scheduled, or if the switchgear is not immediately energized after installation, temporary power must be made available for the operation of the space heaters provided in the switchgear in order to prevent condensation of moisture within the housing.

Compartments are provided with louvered openings and dust filters, both front and rear, top and bottom, so arranged as to permit a good circulation of air. Filters should not be removed except for maintenance.

CONTROL STORAGE BATTERIES

Storage batteries should be given special attention as soon as they are received, but due to the number of battery manufacturers and the variety of types and sizes of batteries only general instructions can be given in this publication. In all cases, the descriptive material supplied with the battery by the battery manufacturer should be followed in installing, using, and maintaining any particular storage battery.

These instructions will pertain to control storage batteries of the lead-acid type most usually supplied for use with switchgear. As soon as practicable after a battery is received it should be unpacked and inspected for any shipping damage which might have occurred. If such damage is found, file a claim against the carrier and advise the nearest Westinghouse representative at once. In general, batteries which do not have to be shipped overseas are supplied with electrolyte already in the cells. If spillage has occurred such that the electrolyte level is lower than one half inch below the tops of the plates, the cell is probably permanently damaged and a claim should be filed against the carrier for the price of the damaged cells. For batteries shipped overseas, the electrolyte is normally drained from the cells and shipped in bulk containers.

After the cells have been thoroughly inspected, install them in place on the trays or racks provided. Wipe clean all contact surfaces on cell posts and intercell connectors. Do not scrape or use abrasives on lead-plated posts or connectors; wipe clean only. Apply a thin film of NO-OX-ID grease or vaseline. Bolt the connectors to the posts tightly being careful to connect the positive post of one cell to the negative post of the next adjacent cell.

Each battery should be given a freshening charge before being placed in service. If the battery is not placed in service shortly after receipt, it should be given a freshening charge no later than 6 months after receipt and at least once in every 6 months period thereafter until it is placed in service. To give the battery a freshening charge, set the charger between 2.30 and 2.35 volts per cell. During the period that the battery is charging, tabulate hydrometer readings for each cell once each hour. The charge should continue until the specific gravity reading of the lowest reading cell shows no further increase in four consecutive hourly readings.

After the battery has been given a freshening charge, it is ready to be placed in service. Readjust the charging voltage to 2.15 volts per cell and maintain the charging voltage at that value. Hydrometer readings for each cell should be tabulated at least once a month during the period of service. If during the course of making monthly readings a particular cell shows a low specific gravity it will be necessary to apply an equalizing charge. This is accomplished by increasing the charging voltage to 2.35 volts per cell for approximately 24 hours. Readings of the specific gravity of the low reading cells should be checked several times during the time that an equalizing charge is being applied. Charging should continue until the lowest reading cell shows no further increase. After the completion of the equalizing charge, the charging voltage must be decreased to the normal floating value of 2.15 volts per cell.

If in handling of the batteries or as a direct result of shipment of the batteries a slight spillage has occurred, add water to the cells or preferably add electrolyte of 1.210 specific gravity and give the battery a full freshening charge. During the life of the battery never allow the water level to get lower than the low level line.

Since the battery contains acid, the usual precautions to protect personnel and materials should be observed. Proper ventilation in the battery room should be provided to prevent an accumulation of hazardous fumes or an explosive mixture of the hydrogen produced during charging. It should be emphasized that a battery requires reasonably frequent inspection and care if it is to have a long life of reliable service. Operating personnel should be familiar with the battery manufacturer's instructions and should observe those instructions in any case of conflict with the general instructions given above. If additional information is required on the operation and care of the battery, the battery manufacturer's service engineer should be contacted immediately.

INSTALLATION

the accuracy and trueness of the concrete floor upon which the switchgear is to be erected. The entire concrete floor upon which the switchgear will be erected must be true and flat (preferably level) and in no place should it vary more than $\frac{1}{8}$ inch in any square yard, and **MUST NOT PROJECT ABOVE THE LEVEL OF THE SUPPORTING MEMBERS.**

Special attention should also be paid to the accurate leveling of the floor adjacent to the housings on the breaker drawout side since the rapidity and convenience in installing and removing the circuit breaker elements will be facilitated by a smooth hard floor surface.

Fig. 14 shows the recommended methods of installing the floor channel steel for an adequate foundation. Methods 1 and 2 are preferred when welding equipment is available, to eliminate the need for accurate lining up of bolts. The steel supporting channels used in the floor should be brought to the true plane of the finished floor (preferably level) and held there until the concrete is set.

When installing metal-clad switchgear on existing floors, it will usually be desirable to pour a new finish floor with embedded channels, or to cut slots in the floor for embedding and leveling the supporting channels.

Encircling loops of reinforcing or building steel around single phase conductors should be avoided in the areas for main cables—when these circuits are rated at 600 amperes or above.

Outdoor Switchgear. For outdoor switchgear a base frame of steel members is included as part of the switchgear so that it is only necessary to install a suitable foundation on which to set the switchgear.

CONDUIT LAYOUT AND SWITCHGEAR FLOOR PLAN

Provisions must be made in floor or foundation for the conduits which carry the main cables, control wiring, and ground cable when such conduits enter the switchgear from below. A floor plan or base plan drawing is made for each metal-clad switchgear order. This drawing must be used for determining the final conduit layout, spacing of floor channels, and floor space required for each metal-clad switchgear structure.

Conduits should project above the finished floor approximately two inches for indoor switchgear and approximately 8 inches above the foundation for outdoor switchgear, and be located according to the floor plan or base plan prepared especially for the individual metal-clad switchgear order. If more than one control conduit is required per unit, for indoor switchgear, these should be aligned in the space allotted for them on the floor plan.

Figs. 15 and 16 present typical floor plans and tables of dimensions for the various ratings of

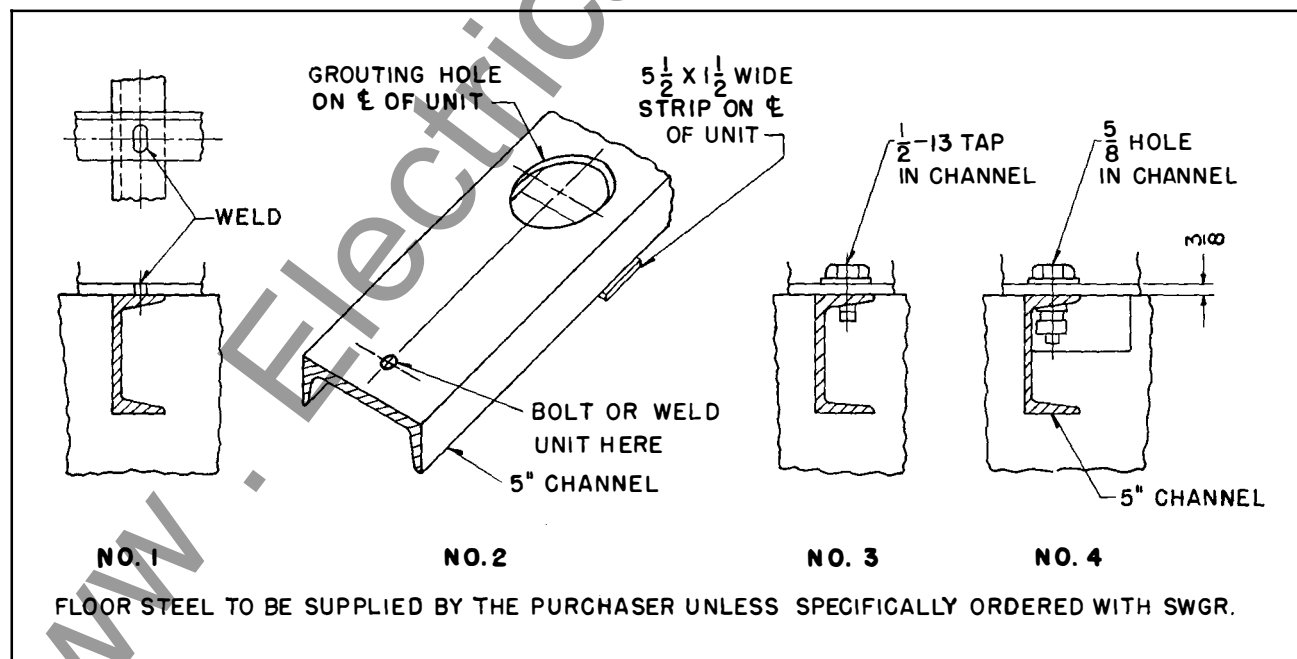

FIG. 14. Suggested Methods of Installing Steel Channels in Floor

metal-clad switchgear. These figures are for standard units and may be used for preliminary layouts or for planning future additions. For final layouts only the properly identified floor plan or base plan supplied by the factory should be used.

For indoor installations it is desirable to provide a blocked out slot in the floor or to provide clearance holes around the secondary conduits so that minor bending of the conduits can be made when the switchgear is installed. The space available for the conduits is quite limited as shown in Fig. 16 and minor bending of the conduits is sometimes necessary to correct for errors in locating the conduits and for accumulated positive tolerances in long switchgear structures.

INSTALLATION OF HOUSINGS

When correctly installed the housings for both indoor and outdoor metal-clad switchgear should make a pleasing appearance and conform to the following requirements:

1. Front panels form a straight true line.
2. Units correctly spaced from center to center and plumb.
3. Rails level in all directions.
4. Entire assembly of housings securely fastened to floor channels or base pad.

Indoor Housings. For indoor housings the following suggestions and general order of operations will assist in obtaining the above requirements without difficulty. Fig. 17 illustrates the general assembly of indoor housing groups and end covers.

1. When three or more shipping groups of the switchgear are to be arranged in one continuous assembly, **THE CENTER SHIPPING GROUP OF UNITS SHOULD BE THE FIRST LOCATED.** The other shipping groups should then be installed in successive order in each direction from the center of the structure.

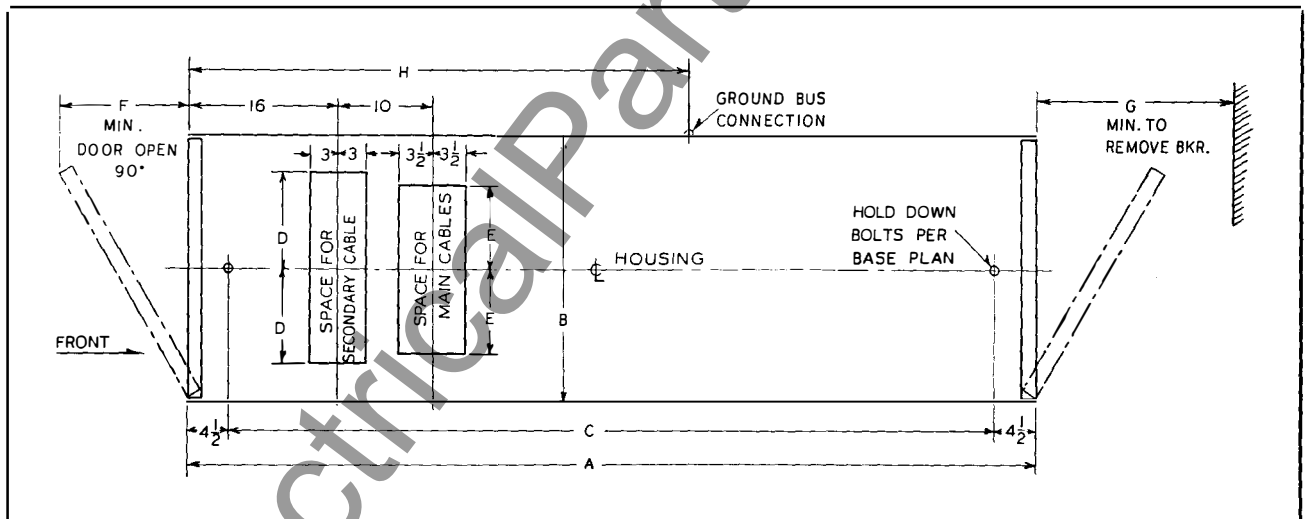

FIG. 15. Typical Base Plan for Outdoor Metal-Clad Switchgear

Table No. 2. DIMENSIONS IN INCHES

Dimensions are approximate only. Refer to properly identified drawing for particular installation.

UNIT	A	B	C	D	E	F	G	H
50-DH-50 Breaker Unit	90	28	81	11 ³ / ₈	10 ¹ / ₄	28	42	53
50-DH- { 150 Breaker Unit 250 Breaker Unit	90	28	81	11 ³ / ₈	10 ¹ / ₄	28	42	53
		38	81	16 ³ / ₈	15 ¹ / ₄	38	49	53
Auxiliary Unit { 30" Wide 38" Wide	90	30	81	30	42	53
		38	81	38	49	53
75 } -DH- { 150 Breaker Unit 150 } 250 Breaker Unit 500	102	38	93	16 ³ / ₈	15 ¹ / ₄	38	49	60
		38	93	38	49	60
Auxiliary Unit	102	38	93	38	49	60

INSTALLATION

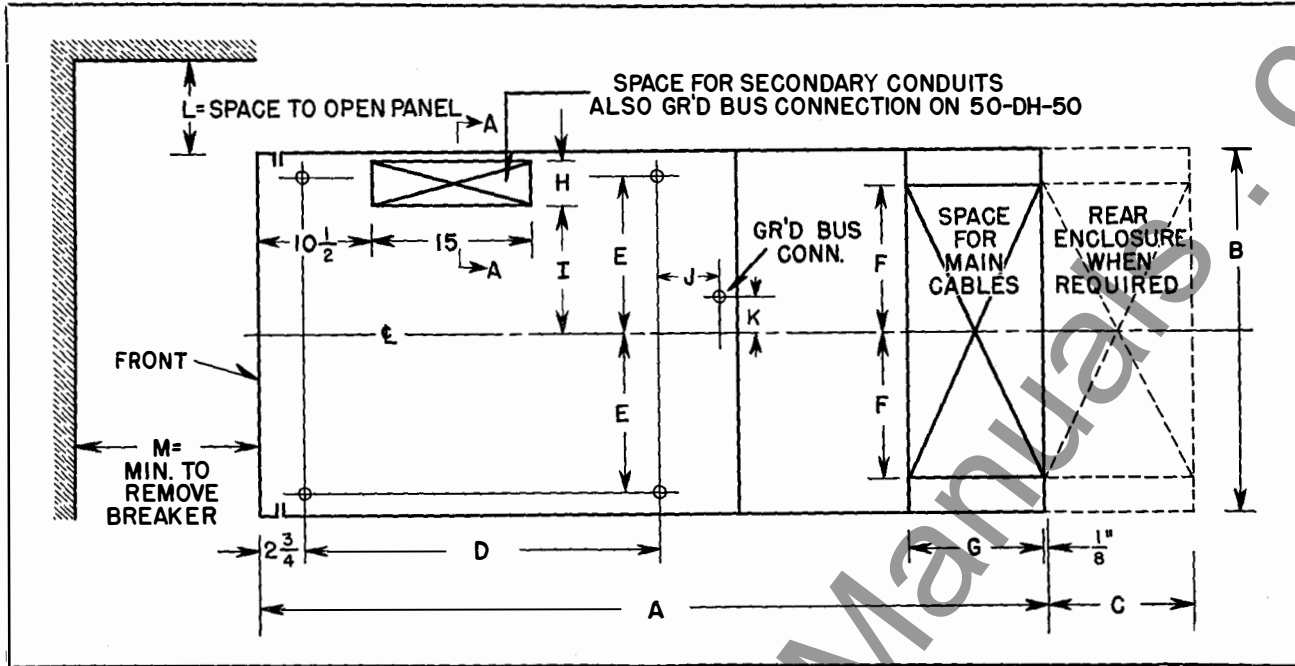

FIG. 16. Typical Floor Plan for Indoor Metal-Clad Switchgear

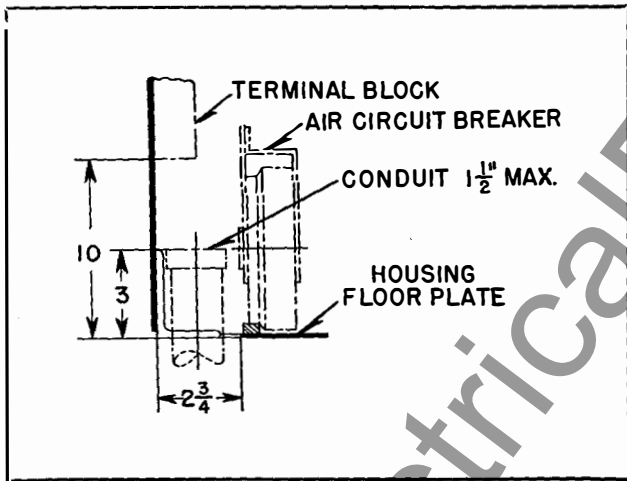

FIG. 16a. Section "A-A" of Fig. 16

2. Remove all crating and packing material, except skids from the first group to be erected. Great care should be taken in removing the crating so as not to damage any of the delicate instruments and relays which may be mounted on the switchgear.

3. Move the first group of units into position either by crane or by pipe rollers. The rollers, if used, should be high enough to allow the switchgear to pass over the conduits projecting above the floor.

Table No. 3. DIMENSIONS IN INCHES

Dimensions are approximate only. Refer to properly identified drawing for any particular switchgear installation.

UNIT	A	B	C	D	E	F	G	H	I	J	K	L	M
50-DH-50 Breaker Unit	64	20	10	32	8 3/16	7 15/16	7 1/4	2 3/4	7 3/16	13	36
20" Auxiliary Unit		30						4	3 1/16				
30" Auxiliary Unit		26						2 3/4	8 1/16				
50-DH- (150 Breaker Unit 600-1200A 250 Breaker Unit 2000A)	74	26	10	36	11 1/16	10 15/16	9 3/4	2 3/4	10 3/16	5	0	17	36
26" Auxiliary Unit		36						4	15 3/16	0	23	43	
36" Auxiliary Unit		26						4	6 1/16	17	36
36" Auxiliary Unit		36						4	11 1/16	23	36
75 150 DH- (150 Breaker Unit 250 Breaker Unit 500)	86	36	12	47	16 1/16	15 15/16	9 1/8	2 3/4	15 3/16	5	5 1/2	23	49
36" Auxiliary Unit								4	11 1/16		

4. Establish a base line a few inches in front of the group of housings and parallel with the desired front of the structure. Equalize the distances from the front of the housings to the base line, thus making the face of the group parallel to the base line.

5. With an accurate level check the rails for levelness, both laterally and longitudinally. These level checks should be made at points just inside the front doors and also about a foot from the rear barrier. Elevation errors should be corrected by inserting shims under the rails and side frame angles as shown in Fig. 18. These shims should always be inserted at the points where the units are to be fastened to the floor channels. If considerable shimming is required, the rail tips should be bent down slightly as shown in Fig. 19 to pick up the small wheel diameter when breaker is rolled into the housing.

6. Check the plumbness of the housing by dropping a plumb line from the center of the horizontal steel member at the top front of the housing. Place a steel bar across the rails just inside the door and mark on it the exact center between the

rails. If the point of the plumb bob registers with the mark on the bar of steel the housing is plumbed satisfactorily. If the housing is not plumb, it may be due to insufficient accuracy in leveling the foundation members, or to distortion of the housing frames due to rough handling in shipment. Leveling may be remedied by checking the shimming. Distorted frames will usually be evident from bent frame members. Each housing of the group should be checked in this manner and corrected if necessary.

7. The second group should then be moved into position and the procedure outlined for the first group repeated. The groups should be bolted together by installing the tie bolts as illustrated in Fig. 17. Then a final check of each housing for levelness and plumbness should be made to insure that the housings have not shifted. Should it be necessary to use any shims in the final leveling, these shims should be inserted as described above.

8. After all units are properly aligned they should be fastened to the foundation by bolting or welding to the floor channels as shown on the floor plan drawing and in Fig. 14.

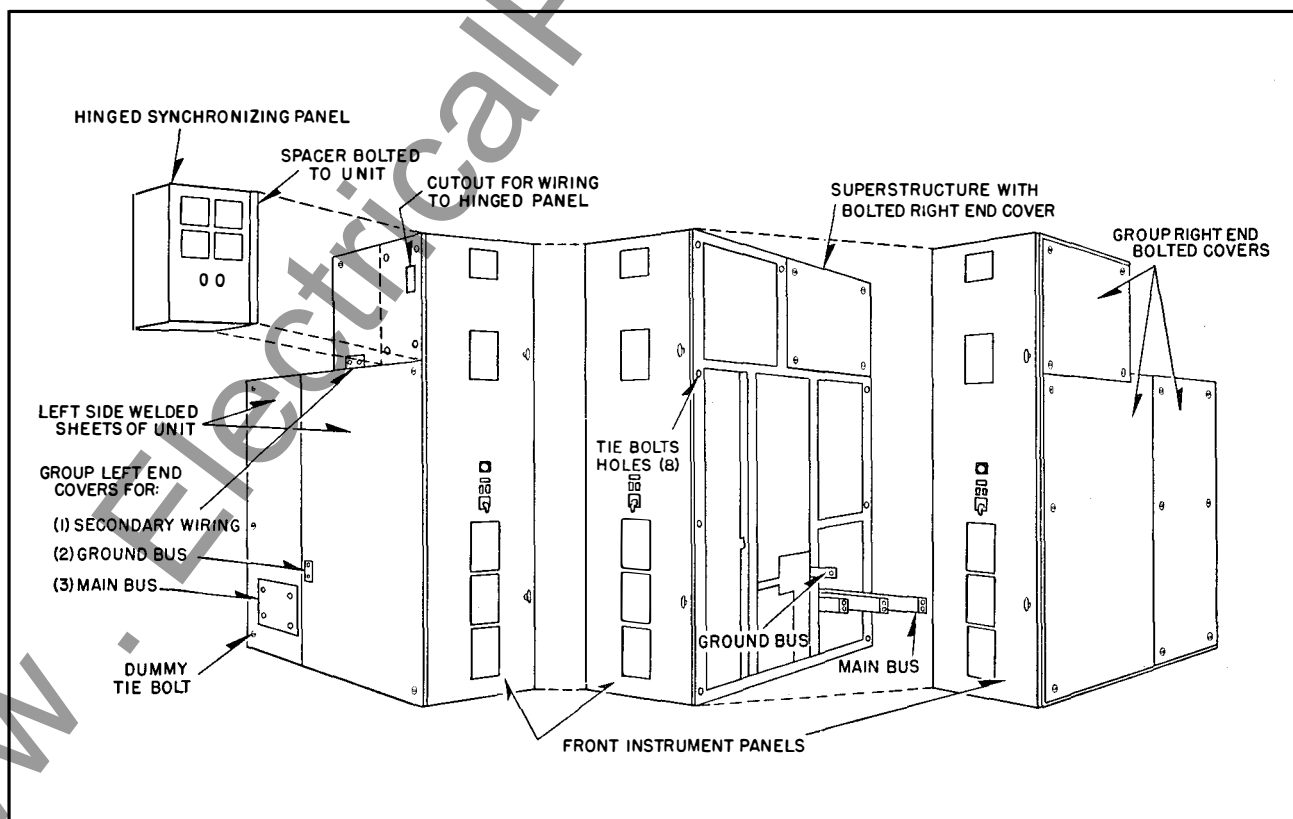

FIG. 17. Assembly of Typical Indoor Metal-Clad Switchgear

INSTALLATION

The preceding discussion and procedure is based on a level floor, as level floors are generally used, and because the level construction is a convenient method of obtaining a true flat floor. The switchgear will operate satisfactorily on a floor with a uniform slope provided the floor is true and flat and does not vary more than $\frac{1}{8}$ inch in three feet in any direction. When installing switchgear housings on a floor with a uniform slope, the rails should be parallel to the floor and the vertical center line of the housings should be perpendicular to the floor instead of level and plumb as described in steps 5 and 6.

Outdoor Housings. For outdoor housings each unit is provided with a formed steel base with a heavy structural steel member at the front and rear which supports the unit on the Customer's base pad. When field handling facilities permit or the overall installation of outdoor metal-clad units does not exceed four to six units the complete assembly will be shipped in one group.

To install a single group assembly it is merely necessary to move it to the desired location on the foundation or base pad and bolt it down.

For installations consisting of two or more shipping groups the installation of the shipping groups should begin with the center group using a base line as outlined for indoor metal-clad switchgear except when installing a unit substation. When

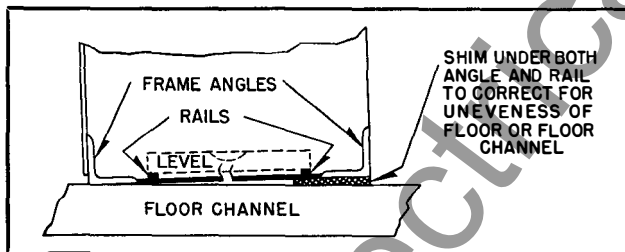

FIG. 18. Leveling the Units with Shims

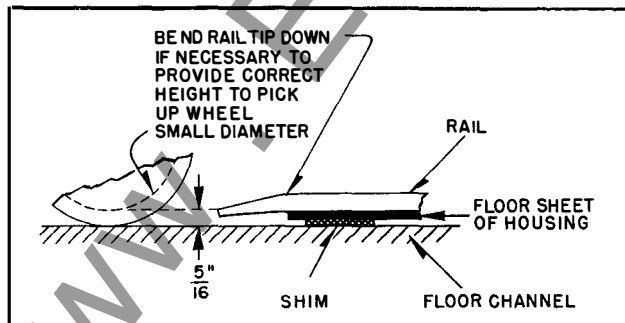

FIG. 19. Adjusting Rail Tips

installing a unit substation, the power transformer and the adjacent metal-clad group should first be lined up and set in position in accordance with the dimensions on the base plan drawing for the installation. The additional switchgear groups should then be installed using a base line as above.

Fig. 20 indicates field assembly for outdoor metal-clad switchgear, and should be followed closely to insure that all weatherproofing trim plates are installed between shipping groups, that groups are securely bolted together, and that weatherproof end sheet and roof end cover are installed.

POWER TRANSFORMER CONNECTIONS

Switchgear assemblies are frequently located adjacent to power transformers to form Unit Substations or Power Centers. In such cases the power connections between the switchgear and transformer are included as part of the assembly. The design of these power connections may be divided into three general types as follows:

1. Bus run type with throat connection.
2. Removable box enclosure type with throat connection.
3. Close-coupled type (for dry type indoor transformers).

For outdoor substations these connections must have weatherproof enclosures and must provide flexibility for the connections between the transformer terminals and the switchgear bus. The design of such connections for indoor substations is similar except to omit the weatherproof features.

Bus Run Type. Figure 21 shows the construction details of an outdoor bus run type of throat connection with the bus run extending from the left hand of the assembled switchgear. A variation of this type would have the bus run emerging through the roof of the switchgear assembly rather than the end unit. For this type of installation the switchgear group adjacent to the transformer and the transformer should be installed first in accordance with the base plan. The flanges of the switchgear bus run and the transformer throat should normally then be in alignment with one another. Apply cement to both flanges on the outside surfaces and cement felt in place in accordance with details shown in Figure 21. The felt is used to seal against entrance of dust and to prevent possible vibration of the sealing section due to resonance produced by the transformer. Install the sealing section by sliding the frame down from the top and secure in place with the screws supplied on the bottom section.

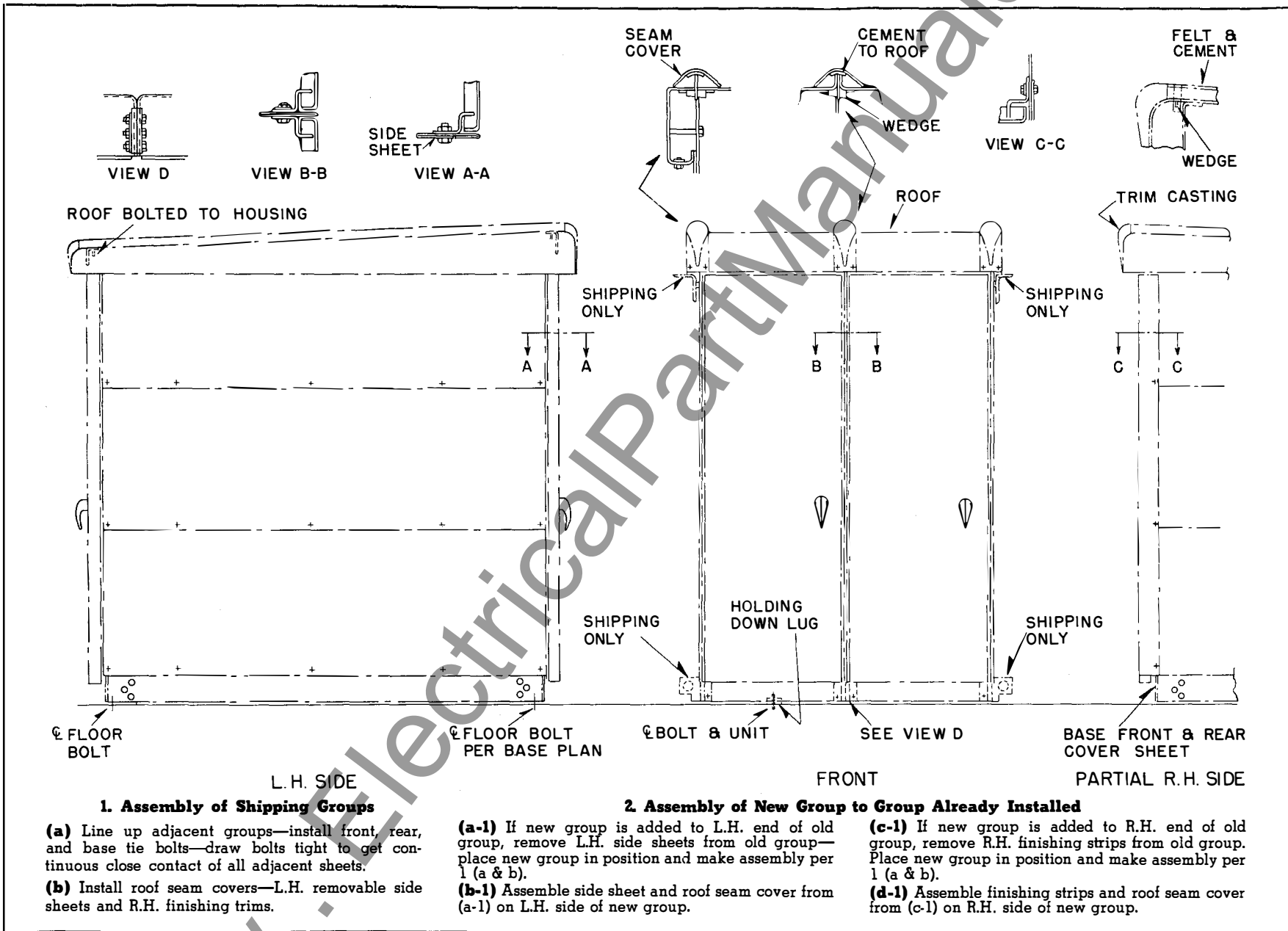

FIG. 20. Field Assembly—Typical Outdoor Metal-Clad Switchgear

INSTALLATION

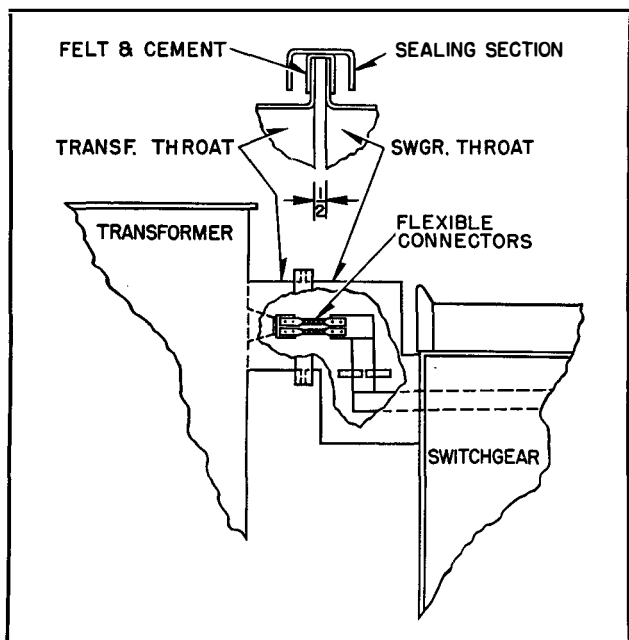

FIG. 21. Bus Run Throat Connection to Transformer

Box Enclosure Type. This type as its name suggests consists of a box which can be assembled in the field to enclose the connections between transformer and switchgear. This type of connection is generally limited to use with outdoor switchgear assemblies. IL 48-300-1 included with the transformer instruction book gives complete assembly instructions.

Install the transformer and first group of switchgear in accordance with the base plan drawing supplied with the equipment; then install the box enclosure. The flanges of both the transformer and switchgear throats should project a short distance within the box enclosure.

Close-Coupled Type. This type of connection is limited to installations involving indoor equipment comprising a dry type power transformer and indoor switchgear assembly. Typical front view sketches of two types of close-coupled assemblies are shown in Figure 22 and a photograph of a typical transformer connection is shown in Figure 23. The specific details of the power connections for any particular combination of transformer and switchgear are shown on the assembly drawings supplied with the equipment.

For installations of this type, locate the transformer and adjacent switchgear unit in accordance with the base plan supplied with the equipment. The transformer and switchgear generally will be arranged so that the front panels of both are located in the same vertical plane. The end unit of switchgear and the transformer should be bolted together using the tie bolt holes provided for that purpose. Connection between the switchgear ground bus and the ground pad in the transformer should be installed at this time.

Control Conduit. For installations where the power transformer and switchgear assembly are located adjacent to one another in accordance with one of the three methods previously described, there is frequently a requirement for connecting certain control circuits from the switchgear to the transformer. These connections are usually made through control conduit installed between the switchgear and the transformer. The specific means provided for any given assembly will be shown on the drawings for that installation.

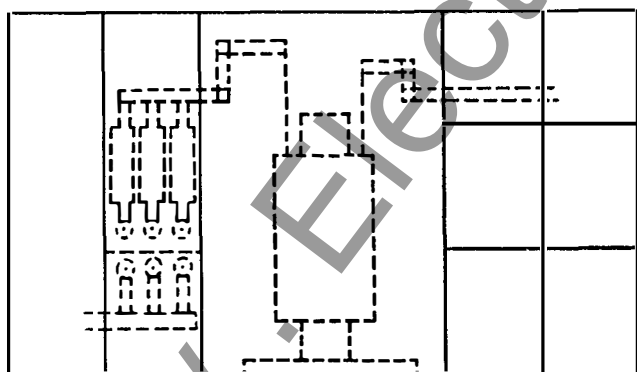

H.V. SWGR. TRANSF. L.V. SWGR.

TRANSFORMER CONNECTED TO "LINE" SIDE OF HIGH VOLTAGE BREAKER

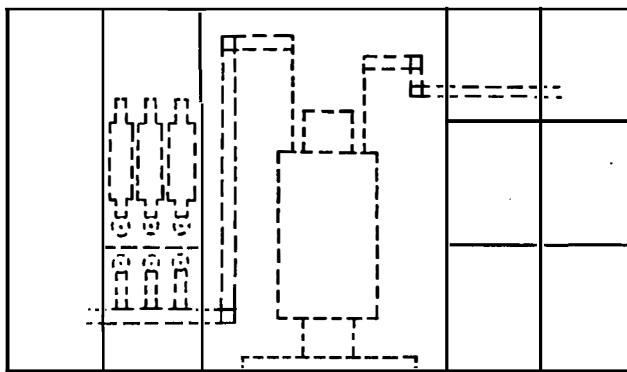

H.V. SWGR. TRANSF. L.V. SWGR.

TRANSFORMER CONNECTED TO "BUS" SIDE OF HIGH VOLTAGE SWITCHGEAR

FIG. 22. Typical Sketches of Close-Coupled Indoor Unit Substations

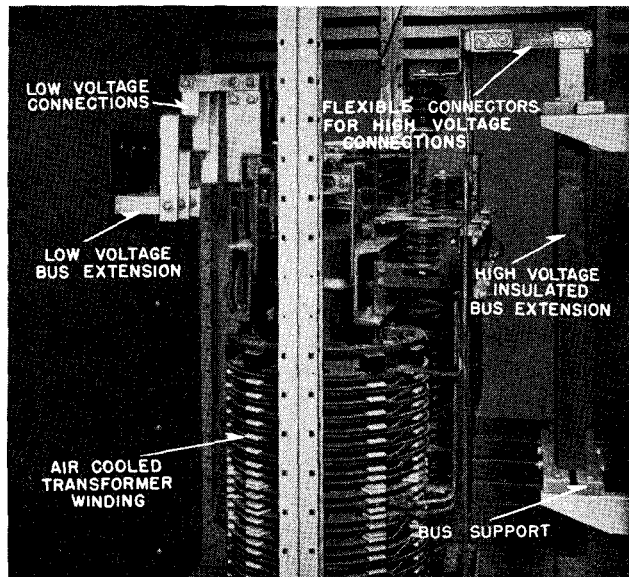

FIG. 23. Connections to Transformer. (Taping has been omitted from the flexible connectors to illustrate method of installation.)

INSTALLATION OF BUS CONNECTIONS

The main bus and any transfer bus or tie bus connections are all completely assembled and fitted at the factory. Sections of bus for the shipping group breaks are then removed, identified, and shipped as detail items for final installation in the field. Figures 24, 25 and 26 show a typical plan view and details of the bus construction.

The following steps should be followed in making the final installation of main copper connections:

1. Clean the silver plated contact surfaces by rubbing lightly with crocus cloth and then wipe

with a cloth moistened in a cleaning solvent such as Stoddard's Solvent (Westinghouse number 1609—a petroleum hydro-carbon solvent). **CAUTION**—This is a flammable liquid having a flash point of 100°F. Keep sparks and flames away. Do not breathe large quantities of vapor. Avoid continuous or excess contact with the skin.

2. Bolt the bus bars together using the splice plates and hardware supplied for that purpose. Bear in mind that the conductivity of a bolted or clamped joint is proportional to the pressure applied. Note however that excessive pressure applied to the hardware will result in stressing it beyond the yield point so that further tightening is impossible. Recommended tightness for various types of hardware are shown in Table 4.

3. Install compound boxes over the joint as shown in Figure 26. Boxes are held in place by means of four molded clamping members which slide over matching tapered lugs on the two halves of the box. In installing the clamps note the taper and slide them over the lugs on the box from the center out. A light coating of varnish should be applied to the wedge before clamping to seal it in place. Pressure of a thumb and finger is sufficient to clamp the box in place.

4. Fill the boxes with Westinghouse compound No. 1001 which is supplied for that purpose. (Do not use pothead compound) This compound should be heated to a temperature between 150 and 160°C. and then poured into the box through the opening in the top. A second filling should be made to take care of any shrinkage after the first filling of compound has cooled. The final cold level of compound

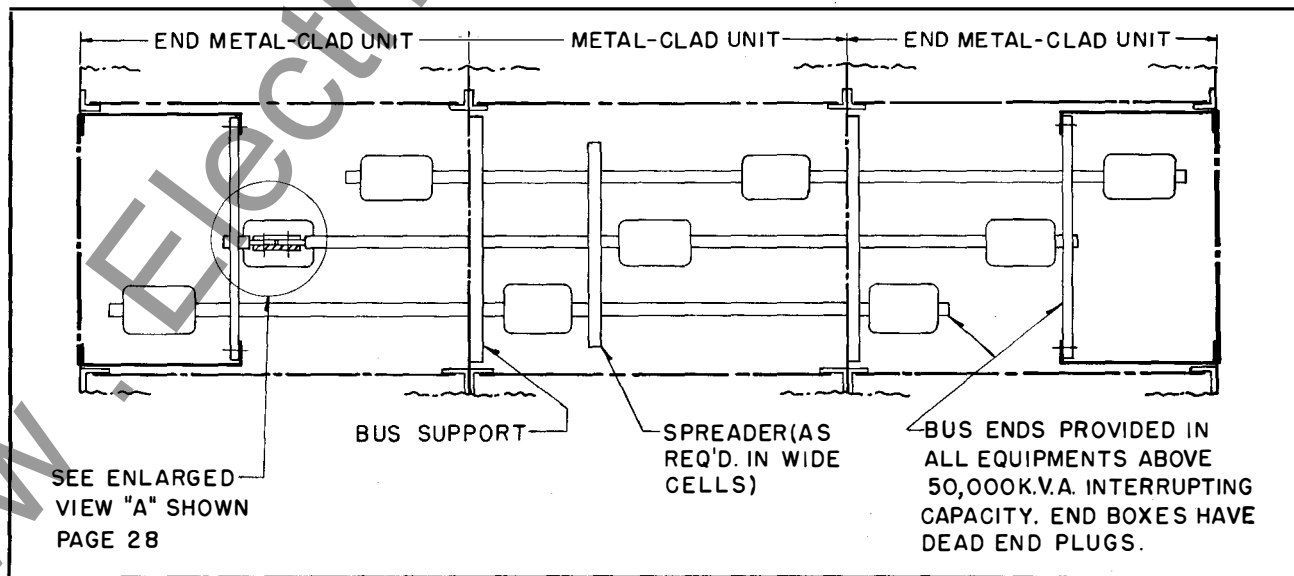

FIG. 24. Plan View of Typical Main Bus Installations.

INSTALLATION

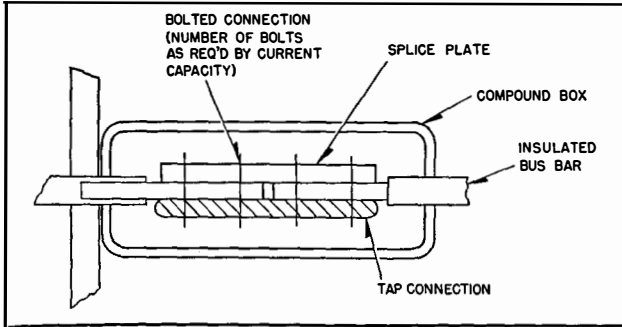

FIG. 25. View "A"—Detail of Bolted Joint

should be approximately $\frac{3}{8}$ " below the top of the box. The pouring of compound will be facilitated by using a funnel that has an extension of flexible conduit soldered to it.

5. Besides the joints in the bus assemblies, compound boxes are supplied for enclosing the joint between the breaker upper main stationary disconnecting contacts and current transformers and also between the breaker lower main stationary disconnecting contacts and copper connections to the main bus. General procedure as outlined for the bus type compound boxes will apply to these other types of joints.

6. All other joints not insulated with compound boxes, including flexible connectors, should be taped in accordance with Figure 27 and taping instructions which follow. Tape and varnish are included with the switchgear shipment for this purpose.

DO NOT FAIL TO COMPLETE TAPING AND POURING OF COMPOUND BEFORE PUTTING EQUIPMENT IN SERVICE.

Table No. 4. BOLT TIGHTNESS FOR BUS AND CONNECTIONS

Use the following torque values for tightening bus and connection joints (tolerance, plus or minus 25%).

Use widest standard flat washers consistent with bolt spacing.

BOLT MATERIAL	TORQUE IN FOOT POUNDS FOR BOLT DIAMETER				
	$\frac{1}{4}$	$\frac{5}{16}$	$\frac{3}{8}$	$\frac{1}{2}$	$\frac{5}{8}$
HEAT TREATED STEEL	5	12	22	55	75
SILICON BRONZE	5	10	15	40	55

TAPING

Wrap with half-lapped layers of .010 inch varnished cambric tape (Westinghouse No. 1266 tan treated fabric) applying as many layers as given in the Table Figure 27. Apply a coat of number 3395 clear insulating varnish between layers.

Cover the varnished cambric with one layer of .007 inch cotton tape No. 7560-1 and wrap the ends with cord or friction tape to keep them in place. Apply one coat of shellac No. 1133-2 and finish with one coat of colored insulating enamel (No. 7260-4 black or No. 5928-3 red). The color of the final finish to be used on any particular taped joint should match the color of the component parts adjacent to the joint.

A properly taped joint will have the tape wound tightly following as closely as possible the contour of the joint so as to eliminate dead air spaces under the tape. When finished, the taped joint should be smooth and glossy to facilitate wiping away dust and should present a pleasing appearance. One important thing to note is the fact that it is unnecessary to wait for the various layers of insulating paint to dry before proceeding with successive layers of tape or other finishes. The various insulating paints may remain tacky for as long as 8 hours or more after being applied. However it is not necessary to wait the complete drying of these paints before energizing the equipment as there is no appreciable difference in insulating qualities between the wet and dry conditions. Normal elevations of temperature which occur during operation of the equipment will speed up the drying process.

MAIN POWER CONNECTION

Metal-clad switchgear is usually provided with either solderless cable connectors or sealed pot-heads for connecting to main power cables. The

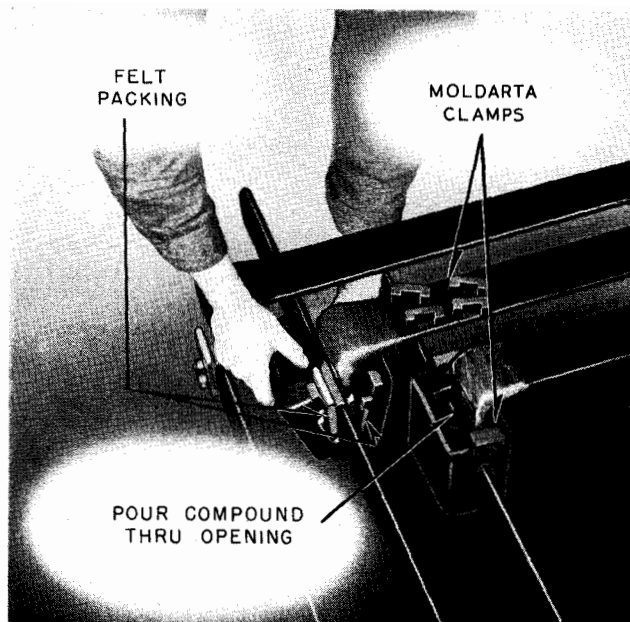

FIG. 26. Installation of Compound Box

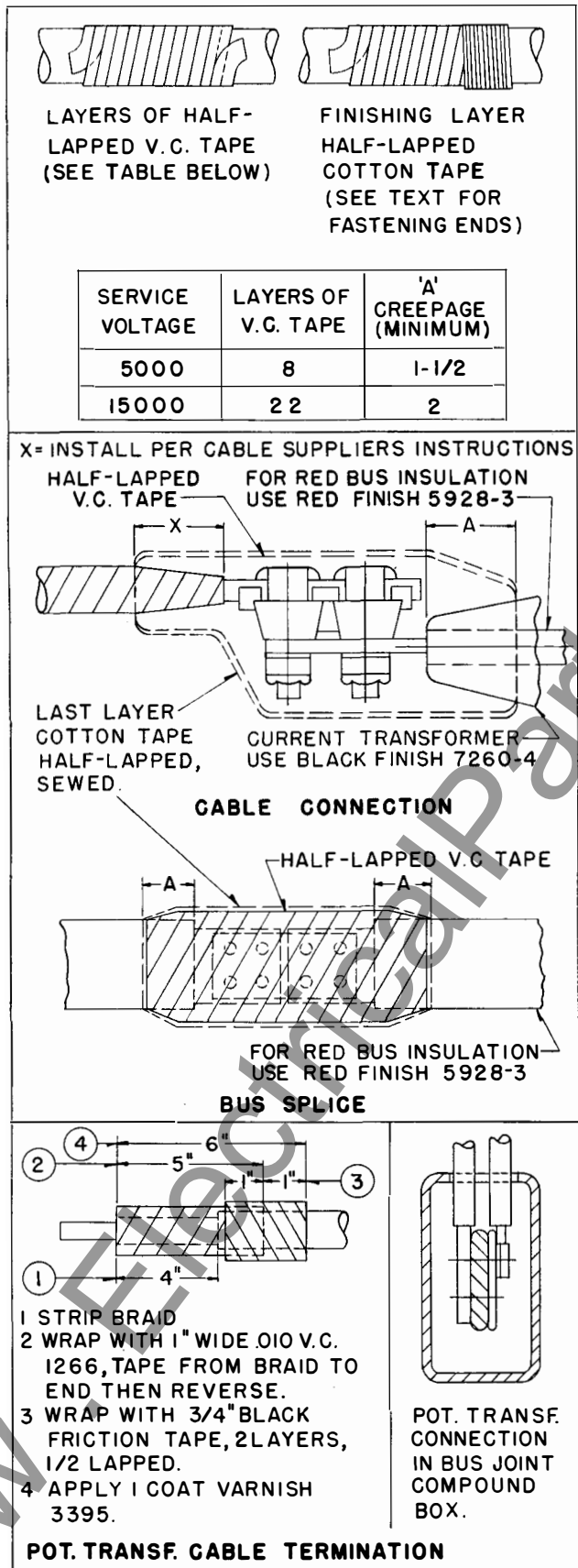

FIG. 27. Taping Instructions

pictures shown in Figure 28 are typical of these two types of termination.

Before making up the connections, the phase of each cable should be determined in accordance with the connection diagram and the cables should be tagged accordingly. Normally Westinghouse switchgear is supplied with connections for phase rotation 1-2-3 per N.E.M.A. Standards unless otherwise noted on the connection diagrams.

When more than one cable is used per phase and all cables cannot be run in a single conduit, one cable from each phase should be run in each iron conduit; or conduits of non-magnetic material should be used.

Any connections that may have been removed for shipping purposes should be reconnected in accordance with previously described methods for cleaning and bolting main bus connections.

Potheds. Connections of cable into potheads should be made in accordance with the pothead manufacturer's instructions included in supplementary instructions or with the potheads. Flexible connectors are provided to connect the pothead aerial lugs to the copper bars in the switchgear so as to avoid strain on the pothead insulators. Potheads are normally shipped mounted in the switchgear units without the flexible connectors being bolted, and such connections must be completed in the field. It should be noted that flexible connectors are to be taped in accordance with instructions previously given for taping main bus connections.

Solderless Connectors. Solderless connectors are normally furnished for terminating non-leaded cable. In addition insulating clamps are normally provided to separate the cables and to support their weight. The cable manufacturer's instructions should be consulted for the exact details required in terminating any given type of power cable. Cable clamps when supplied may be drilled at the factory if the outside diameter of the cable is known. Since it is frequently impossible for the factory to determine the exact outside diameter of the cable that will be used, these insulating clamps will be supplied with 1/4" diameter pilot holes and must be redrilled to exact size in the field. After drilling, the insulating clamps should be saw-cut longitudinally through the center line of the drilled holes to facilitate installation and to provide proper clamping action.

Flexible Connectors. Flexible connectors are provided to relieve the strain on pothead insulators and may be used with bus runs to allow for expansion of copper bus bars due to heating or in transformer throats or similar applications to facilitate lining up

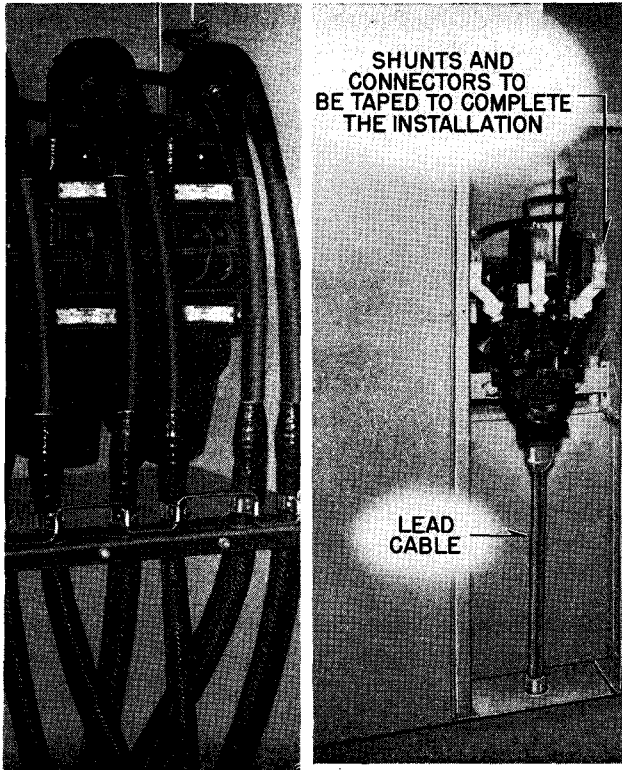

Solderless Connectors and Micarta cable clamp. Two conductors per phase with final taping completed. Sealed Pothead for 3/c cable Flexible shunts prevent strain on pothead porcelains.

FIG. 28. Typical Main Cable Installation.

of adjacent copper bars. No matter when they are applied, **FLEXIBLE CONNECTORS MUST BE TAPED** to provide adequate insulation. Taping instructions previously noted for bus bar connections and/or power terminal connections will apply.

General. When forming cables for termination within switchgear assemblies, avoid sharp turns, corners, and edges in order to prevent damage to, or weakening of, the cable insulation. The cable manufacturer's instructions should be followed closely in determining the minimum bending radii of cables and the proper tapering of insulation to establish necessary voltage gradients. Such instructions will vary with the type and size of cable involved as well as with the service voltage for which the cable is designed to operate.

ADDITION OF UNITS TO EXISTING ASSEMBLIES

When additional units or groups of units have been supplied for extending existing installations, the procedures outlined for installing the initial equipment should be followed. In such cases it becomes necessary to remove the compound boxes from the end unit of the existing switchgear assem

bly in order to extend the main bus into the new units. Any one of the following procedures are recommended for removing the compound from the existing bus joints:

1. With the compound at room temperature chip away the existing box and compound with a dull chisel being careful not to damage the insulating tubing on the bus or the bus itself.
2. Enclose the compounded joint in a cardboard box or other suitable container and pack with dry ice to freeze the compound. Allow the joint to be exposed to the dry ice for approximately two hours, remove the packing, and chip as described in paragraph 1 above. Care must be exercised in handling the dry ice to prevent injury to personnel.
3. Apply sufficient heat to the joint to soften the compound using heat lamps. Do not use open flames as they are apt to mar the finish or cause other damage within the equipment. After the compound has been softened, scrape away using putty knife or similar tool.

After the bulk of the compound has been removed by one of the three methods suggested above, apply a solvent to the remaining compound such as Stoddard's Solvent (Westinghouse No. 1609) to remove the bits of compound that may still adhere to the joint. In using the solvent apply it sparingly to reduce possibility of it migrating into the space between the copper bar and insulating tubing. Repeated applications of a cloth moistened in the solvent is recommended. Remove the bus joint hardware as soon as sufficient compound has been removed to make the bolts accessible. A wire brush lightly applied to the joint may also assist in removing the final bits of compound. After the hardware has been removed, the contact surfaces must be thoroughly cleaned using the cleaning solvent suggested.

When the joint has been thoroughly cleaned the bus may be extended into the new units using the copper bar supplied for that purpose. The bus end brackets and insulating bus support removed from the end unit of the existing gear should then be installed in the new end unit. Compound boxes supplied with the new assembly should then be installed and compound No. 1001 should be poured as previously described.

The above procedures described for removing compound from main bus joints will also be applicable to cases where it becomes necessary to remove any other compound joints.

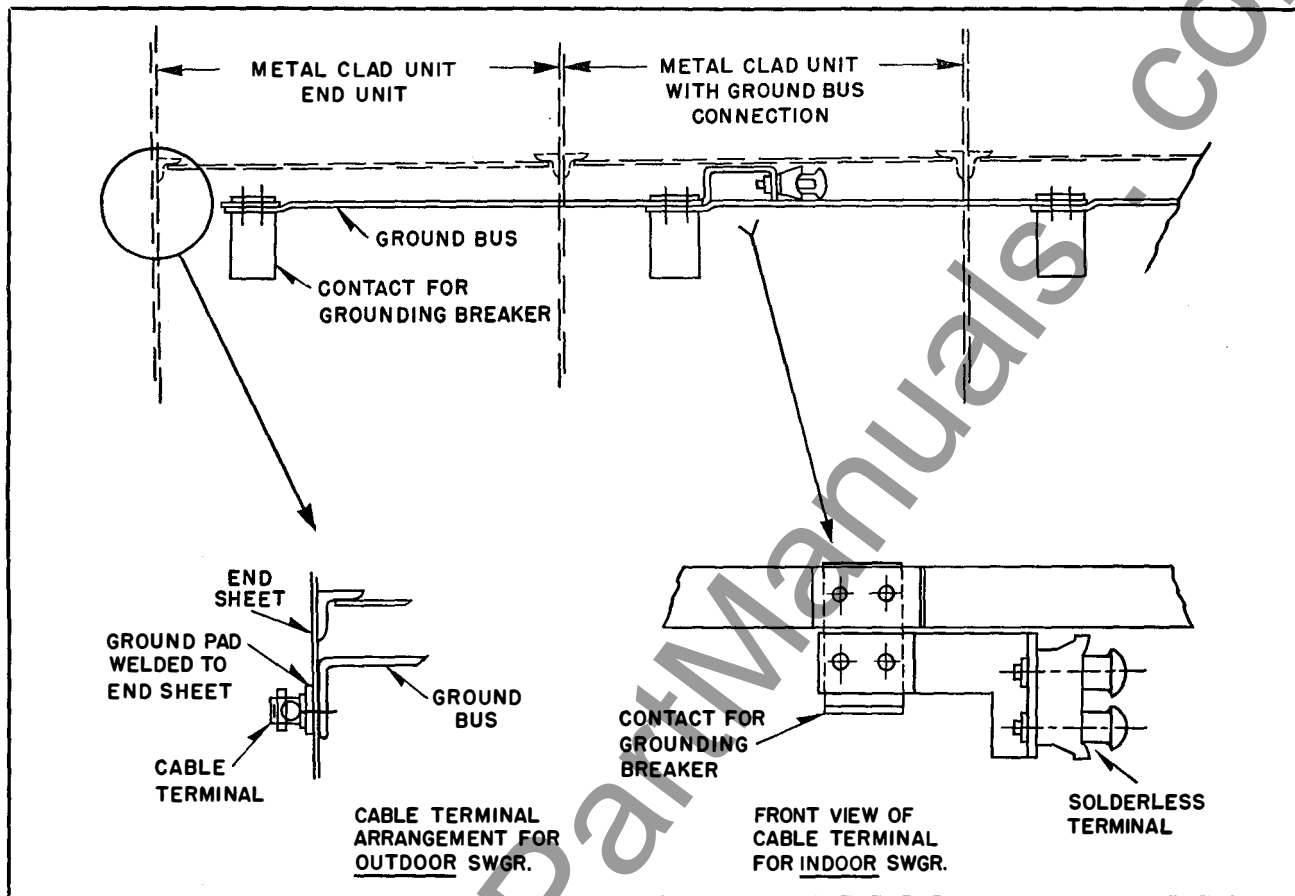

FIG. 29. Plan View and Details of Typical Ground Bus Installation

GROUND BUS CONNECTIONS

The ground bus in the switchgear housings is a copper bar assembled in sections with a joint in each unit. Fig. 29 illustrates the ground bus construction. The section of ground bus between units at shipping group breaks is removed for shipment and must be reinstalled when the units are assembled.

Terminals of the solderless type are provided on the ground bus for indoor switchgear in one or more units as indicated on the floor plan drawing. For outdoor switchgear, the ground bus terminal is located on a welded ground pad on the end of the structure. These terminals are for the connections to the station ground which should be as direct a connection as possible and should not be run in metal conduit.

It is recommended that the connection to the station ground have a cross section of 500,000 circular mils or greater if the soil in which it is buried is of such character as to cause appreciable corrosion. This is especially true where electrolysis from stray currents or contact with dissimilar metals exists. The resistance of the soil surrounding a

station ground depends on the condition of the soil as well as its chemical content. Dry, loose, sandy or frozen soils will have a high resistance as compared with moist soils or soils containing ashes, cinders or salt solution. A variety of methods is available for providing the ground, two of which will be described.

Plate Ground. A very effective ground is obtained by using a copper or brass plate from 10 to 25 square feet area, depending on station capacity, and one-half inch thick. Drill a number of one-half inch holes in this sheet. Place the sheet on a 2-foot layer of charcoal in a pit of sufficient depth to insure contact with permanently moist soil of good conductivity, and deep enough for protection from mechanical damage to plate or cables.

Make permanent connection to the ground plate with standard cable of at least 500,000 cm area. Fan three feet of the strands over the plate surface and solder or braze then securely. Cover the plate with a two-foot layer of charcoal and fill the pit with earth, settling it with a salt solution.

Pipe Ground. A satisfactory ground can also be made from ten pieces of 1½" galvanized iron pipe

INSTALLATION

of sufficient length to reach moist earth (not less than 12 feet). Drive these pipes into the earth placing them symmetrically over an area at least 25 feet square. Connect all the pipes together by a 500,000 cm cable and clamp connections. Bury the cable a sufficient distance below the surface to prevent mechanical injury.

SECONDARY AND CONTROL CONNECTIONS

All secondary and control connections on metal-clad switchgear are factory wired in accordance with the connection diagram applying to the installation. The secondary and control connections which are to be connected to apparatus remote from the switchgear are wired to terminal blocks near to the secondary conduit entrance location.

Openings in the side sheets of control compartments provide access for control connections between housings. When shipment is made in groups of several units, the cross connections are installed in one group at the factory and provisions are made for connecting to the adjacent groups.

Voltage Drop. The control bus for electrically operated breakers is usually of larger size than the balance of the control wiring to reduce the voltage drop, particularly in a long structure. The feed connection to this bus should be checked for voltage drop at the maximum breaker closing current and sufficiently large cable used to insure proper operating voltage at the breaker solenoid. Make sure that the polarity of all the connections from d-c control sources is as shown on the connection diagram.

All connections should be made mechanically and electrically strong and should be checked for proper electrical sequence before being energized. All control and secondary cables to remote apparatus should be connected to the terminal blocks provided and carefully checked for accuracy against the connection diagram.

Loading Check. It is suggested that the loading of the control busses be checked with an ohmmeter to insure against short circuits in the control wiring before energizing initially. If an ohmmeter is not available, serious damage to the control wiring may be avoided by temporarily connecting a small fuse in series with the control source for the initial check.

DISCONNECTING TYPE POTENTIAL TRANSFORMERS

For shipment, the operating links of the potential

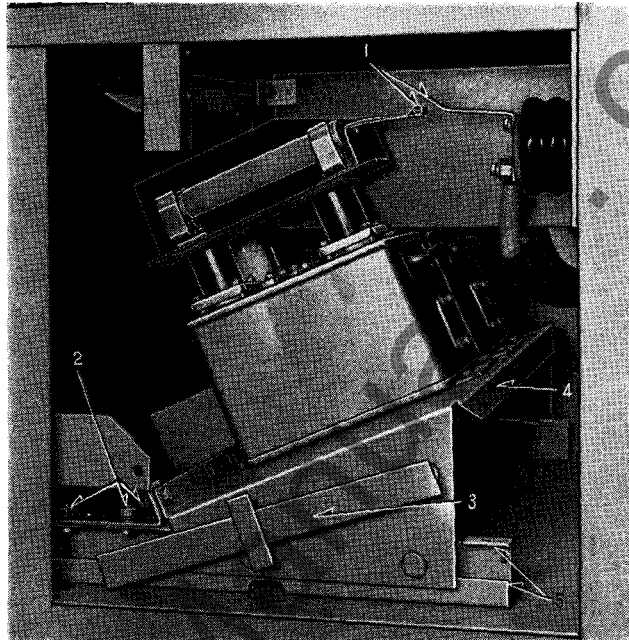

1. Primary contacts separated during shipment to prevent wear by vibration
2. Shipping clamp bolted to drawer and rail.
3. Operating arm disconnected from door and resting on floor of compartment.
4. Movable drawer.
5. Rail.

FIG. 30. Disconnecting Type Potential Transformers in Shipping Position (See also Fig. 8).

transformer drawer are disconnected from the hinged door and the drawer clamped in a position with the contacts disconnected. This is to prevent wear of the contacts due to vibration during transit.

The clamps are small angle shaped pieces which are bolted both to the transformer drawer and to the rails on which the drawer operates as shown in Fig. 30. The links are dropped and laid inside the compartment frame angles.

Before placing the switchgear in operation, the disconnecting drawer assembly should be prepared for operation as follows:

1. Remove angle clamps.
2. Check contact engagement in operating position. The primary contacts should spring between $1/4$ " and $1/2$ " when engaged.
3. Raise door to approximately 30° opening position and connect links to the clips on the door.
4. Check operation of disconnecting drawer assembly and also check engagement of primary contacts with grounding bar.
5. Check fuses to be sure they are good and make proper contact in the clips.

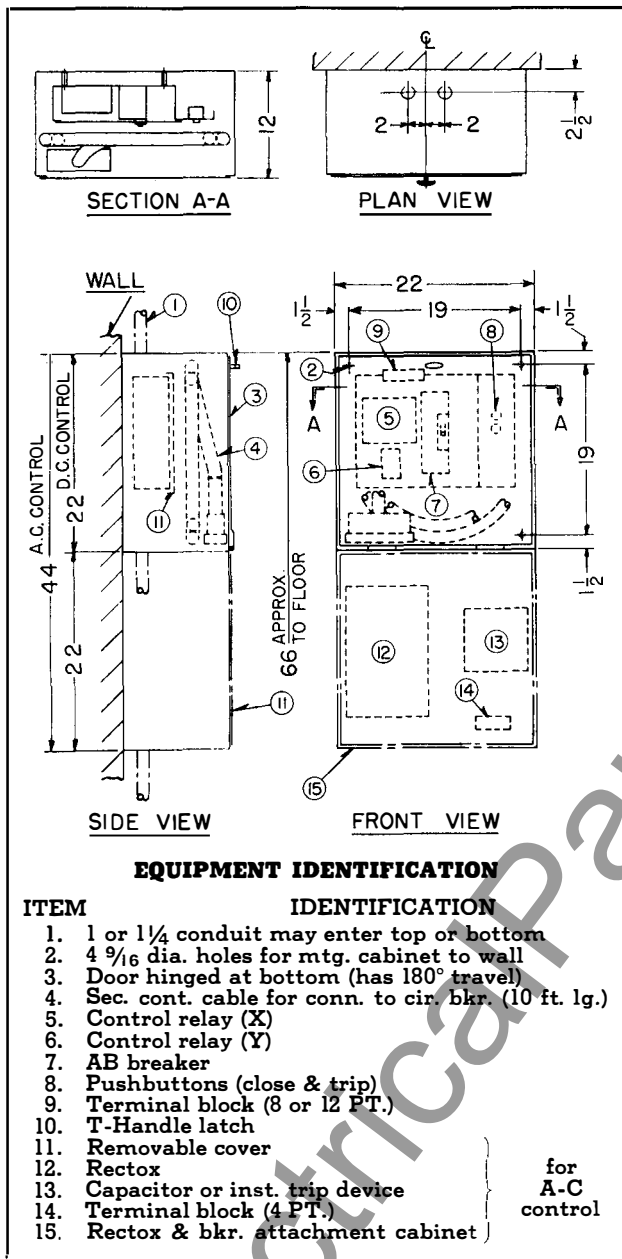

FIG. 31. Test Control Cabinet.

TEST CABINET

The test cabinet is designed for wall mounting and provides means for testing the breaker operation after it has been removed from the structure. The cabinet includes "close" and "trip" push buttons, control relay, a control circuit interrupting device and secondary disconnecting devices with multiconductor extension cable. A closing Rectox and capacitor trip device is supplied, when required.

Fig. 31 is a drawing of the test cabinet and shows the wall mounting dimensions. The cabinet

must be provided with control power and provision is made for a conduit to enter the cabinet.

For indoor switchgear the test cabinet should be located on a wall or building column convenient to the switchgear where the routine testing and maintenance work will be done on the circuit breakers.

For outdoor switchgear a long test jumper is normally supplied to facilitate checking operation of the breaker while on the transport truck outside the housing. When ordered, an indoor type test cabinet is supplied for mounting inside a maintenance building. A special outdoor housing is also available with space for the test cabinet and storage of a spare breaker.

PREPARING BREAKERS FOR SERVICE

The removable breaker elements should be uncrated carefully and thoroughly inspected. The supplementary instruction book for the breaker should be consulted for additional description of the breaker and its operation. The following summarizes the steps to be followed in preparing the breaker for service:

1. Remove any special bracing added to the breaker for shipment.
2. Remove any blocking used to hold the breaker closed during shipment. This blocking may be released by pulling the breaker tightly closed with the maintenance operating handle.
3. Inspect the breaker unit carefully for loose or broken parts or for any foreign material which may interfere with the breaker operation. Repair or replace any broken parts. (Enter a claim with the carrier for any damage that may have occurred during shipment).
4. Check the circuit breaker contacts and the operation of the mechanism as outlined in the air circuit breaker instruction book.
5. Inspect the main disconnecting contacts for damage to the fingers or insulators.
6. Close the breaker slowly with the maintenance operating lever to check the operation of the mechanism and the adjustment of the contacts.
7. Install the arc extinguishing stacks after the above steps have shown the breaker to be in good condition. Inspect the stacks thoroughly before installation for breakage or presence of foreign substances as recommended in the breaker instruction book.
8. After the arc extinguishing stacks have been installed on the breaker, check for proper engage-

INSTALLATION

ment of the rear arcing horn connection and bolt the front arcing horn connectors to the stacks.

9. Operate the breaker slowly by hand to be sure that moving contacts clear the arc stacks.

10. Install the metal insulating barriers. **Never insert a breaker in its unit without having the stacks and the barriers installed.**

11. Check the control wiring for grounds and shorts.

12. Before inserting the circuit breaker in its switchgear unit, insert the levering-in handle and turn it counter-clockwise to extend the levering-in device arm toward the rear of the breaker unit. Continue turning the handle until the arm reaches its stop.

KEY INTERLOCKS

Key interlocks are often supplied in conjunction with disconnecting switches, dummy breakers and special compartments where access is to be denied unless the circuit breaker is withdrawn to the test position. The operation of key interlock schemes is generally described by a note or keying chart on the switchgear assembly drawings.

To facilitate manufacture and installation procedures, extra keys are supplied with each lock. The extra keys will also provide a set of spares for the Purchaser, but should be kept where they will not be accessible to operating personnel.

Caution. Before placing switchgear with key interlocks in operation, the key scheme must be carefully checked and only the proper keys left in the locks. All extra keys must be removed and destroyed or stored where not available to operating personnel.

ADJUSTING AND TESTING

After the switching equipment together with the apparatus which it is to control has been installed and all inter-connections made, it should be given a final check and test before being put into service. This is necessary to insure that the equipment has been correctly installed and that all connections are complete. Extreme care must be exercised to prevent the equipment to be controlled from being connected to the system while the preliminary tests are being conducted.

The testing equipment required will depend entirely on the size and type of installation. Portable voltmeters—both a-c and d-c with a wide range of scales will usually be required and for large and complicated installation, both a-c and d-c ammeters should be available in case unexpected trouble develops. Some simple portable

device for ringing or lighting out circuits should be included in the testing equipment.

Although the inspection and tests given the switching equipment at the factory insures that all the connections on the switchgear are correct and in good order when it leaves the factory the connections should be examined to make sure that they have not been loosened or damaged during shipment or installation. All bolted connections and joints should be tightened to insure good contact.

After installation, the connections to the equipment apart from the switchgear such as instrument transformers, remote control and interlock circuits, auxiliary switches, etc., should either be rung or lighted out to make sure that they are also correct. The extent to which this will have to be done depends on the thoroughness of the installation work. There must, however, be definite assurance that all connections are correct before an attempt is made to operate the equipment.

The relays have been checked and adjusted at the factory to a recommended setting commensurate with the system information available. The final settings of the relays should be coordinated with other parts of the system and determined in accordance with the Purchaser's standards or operating practice. If it becomes necessary to modify these relay settings after the switchgear has been installed, the instruction leaflet for the relay involved should be carefully studied before attempting such modification. These instruction leaflets show typical connection diagrams only and may not necessarily agree with the connections furnished. The schematic and wiring diagrams furnished with the switchgear equipment should be referred to for the actual connections applying to this installation.

The covers for meters, relays and other devices which have to be removed during the course of installation and test should be carefully handled when removed as these are made either partly or entirely of glass. The covers should be put back in place promptly to keep dust and dirt from collecting on the vital relay parts.

After the switchgear has been installed and put into operation, the drawings and diagrams supplied with the equipment should be gone over and notations made on them of any deviation made during the installation. A set of these should be returned to Westinghouse so that the tracings may be changed for permanent record. This is necessary in order that there will be no confusion in handling future orders for changes or extensions.

OPERATION

The operation of horizontal drawout metal-clad switchgear is similar to that of permanently fixed breakers with the added advantages of greater flexibility, safety and ease of maintenance, plus ease of testing and checking control circuits.

All circuit breaker units of the same rating are identical and interchangeable and have the same control wiring so that it is possible to replace any breaker unit with any other unit of the same rating. In addition, the 600 ampere and 1200 ampere breakers of the heavy duty units (i.e. 100,000 kva interrupting capacity and over) are interchangeable so that a 1200 ampere breaker may be used as a spare for either rating, or a 600 ampere breaker can be used in a 1200 ampere housing in an emergency provided that, at the time, the load requirement does not exceed the 600 ampere rating of the circuit breaker. **ALWAYS REFER TO THE NAMEPLATE INTERCHANGEABILITY DATA TO MAKE CERTAIN THAT BREAKER UNIT AND HOUSING ARE SUITABLE FOR OPERATION TOGETHER.**

During operation, all live parts are enclosed by grounded metal sheets which permit the operator to perform his work with maximum safety. Separate metal covers are provided over each different compartment, so that any compartment of a unit may be exposed without exposing other compartments.

The control circuits may be checked accurately and safely by moving the breaker to the test position where the main circuits are disconnected and the control circuits can be completed by moving the secondary contact assembly to the engaged position. (See Fig. 32). No jumpers are needed.

All Type "DH" air circuit breakers are equipped for electrical operation. A maintenance operating handle is supplied as part of the accessories to permit manual operation of the breaker during maintenance. **THIS DEVICE MUST NOT BE USED TO CLOSE THE BREAKER ON ANY ENERGIZED CIRCUIT.**

PLACING BREAKER UNIT IN HOUSING

No attempt should be made to place the removable breaker elements in the housings until after the housing installation is complete. The

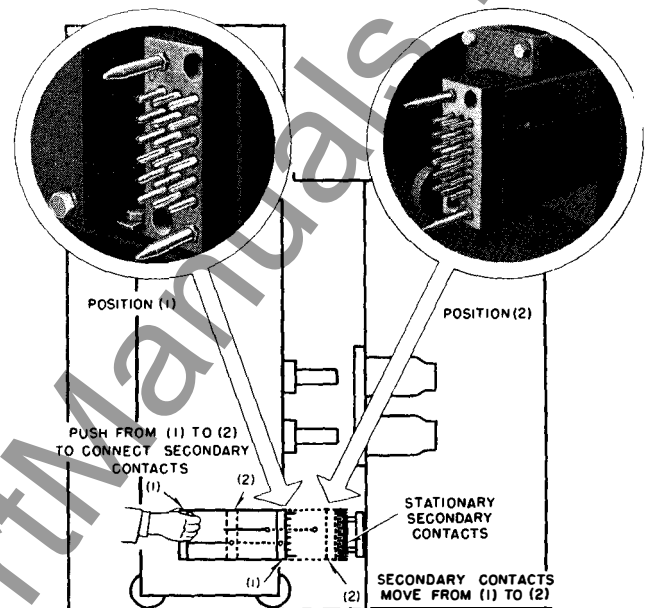

FIG. 32. Engaging Secondary Contacts with Breaker in "Test Position"

insertion of the breaker into the housing is accomplished in three major steps as illustrated in Fig. 33 and as described in the following paragraphs.

1. First, place a breaker unit so that it is directly in front of the housing and aligned so that the wheels will engage with the guides or rails. The handling dolly may be used with the heavy duty indoor units until the breaker is lined up and then it should be removed. For outdoor switchgear the breaker will be on the transport truck and the transport truck is brought up to the housing, the rails matched and the truck then latched to the housing.

2. The second step is to move the breaker by hand to the test position. The levering device arm must be in the rear position against its stop. The breaker should be moved slowly into the housing, making sure that the wheels engage the housing guides and watching carefully for any interference. The breaker should never be slammed into the housing. The test position is reached when the breaker is stopped by the levering device roller.

OPERATION

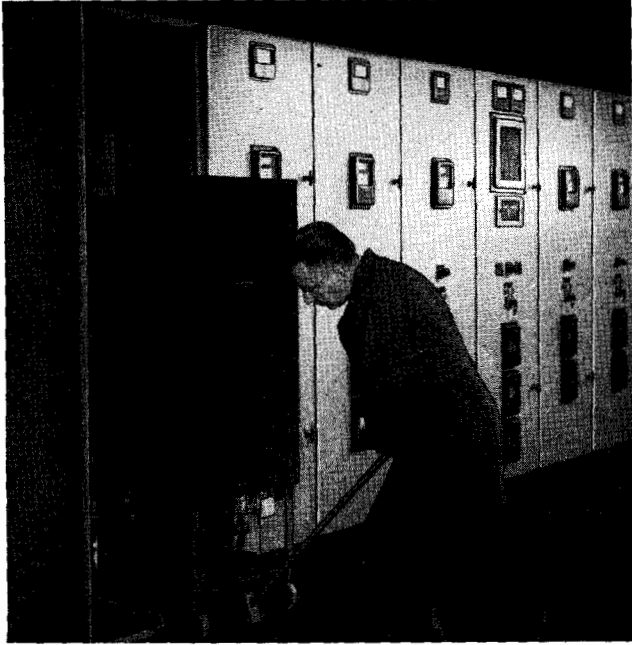

INDOOR

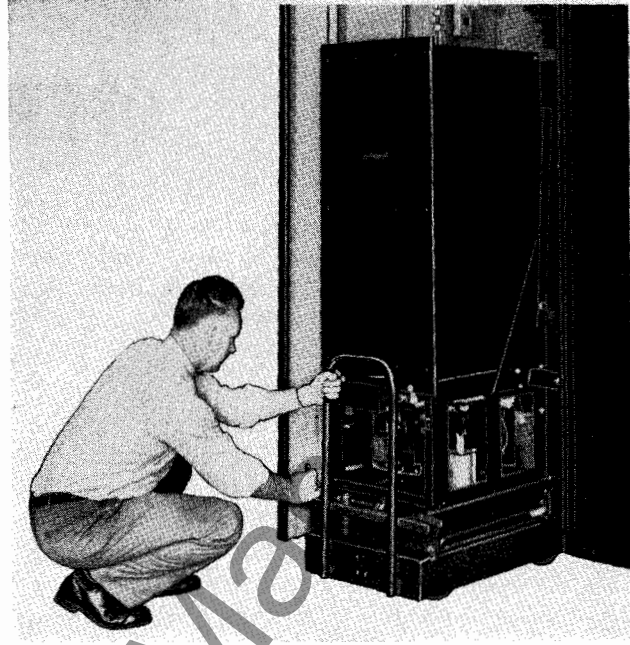

OUTDOOR

1. Bring Up the Breaker. For indoor switchgear, the handling dolly may be used to help line up wheels with the track. For outdoor switchgear, breaker is on the transport truck which is latched to the housing.



2. Push Circuit Breaker to "Test Position". Breaker is stopped at test position by drive-in device.



3. Crank to Connect. Movement from test to operating position is accomplished by a few easy turns of the crank. An interlock prevents crank motion if breaker is in closed position.

FIG. 33. Placing Breaker in the Housing

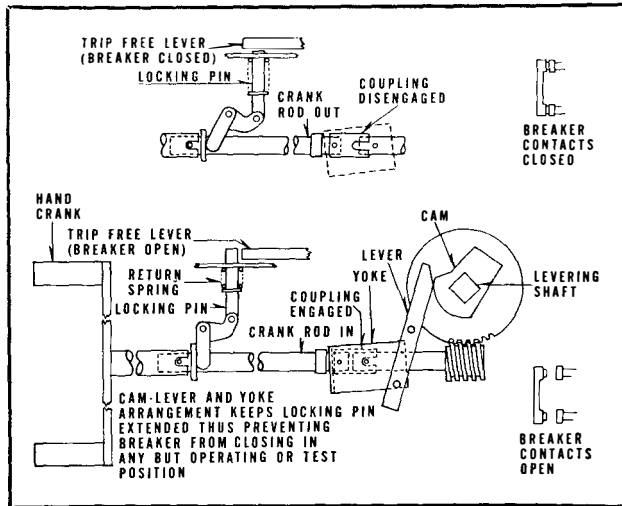

(a) Operation of mechanical interlock between levering device and trip free lever.

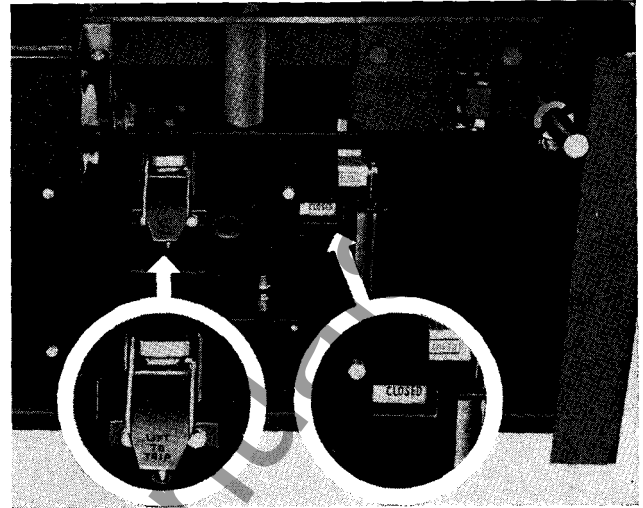

(b) Front view of breaker mechanism. Levering device shaft is at upper right.

FIG. 34. Breaker Mechanical Interlock

3. The third step is to crank the breaker from the test position to the operating position by means of the levering device which is a part of all type "DH" air circuit breakers. If the breaker cannot be readily moved between these positions the trouble may be caused by the breaker being closed, foreign material in housing, or incorrect alignment of housing which might be caused by improper installation or distortion of housing during shipment.

Mechanical Interlock. All ratings of the type DH breakers have a positive mechanical interlock between the breaker mechanism and the levering mechanism so that the breaker must be tripped before the levering device can be operated. On one design of this interlock the blocking device is operated directly by the breaker mechanism. On another design, the blocking members of the interlock are moved by the insertion of the levering handle as shown by Figure 34. In this latter design, positive pressure must be exerted axially along the shaft of the levering handle while it is being turned in order to keep the coupling engaged.

For visual indication of whether the breaker is in the test position or in the operating position, a pointer projects through a slot in the right hand front vertical member of the breaker truck. When the breaker is in the test position this pointer is lined up with a yellow mark painted on the truck member. As the breaker is levered into the cell, this pointer drops down away from the marking. When the breaker has finally been levered into the operating

position, this pointer is raised again directly opposite the painted mark. Since the mechanical interlock prevents the breaker from being closed unless it is either in the operating or test positions this visual indication indirectly indicates whether or not the interlock has operated.

ELECTRICAL OPERATION

General. The control of the circuit breakers and the instrumentation and relaying of the circuits fed from metal-clad switchgear is the same as the control of such circuits from a switchboard or control desk, for the instrument panels of the metal-clad switchgear in effect form a vertical steel switchboard.

A one-line diagram, schematic diagram, and detailed connection diagrams are prepared for each metal-clad switchgear assembly. These diagrams, especially the one-line and schematic, should be thoroughly studied and completely understood by the operators of the metal-clad switchgear.

The reading of indicating and recording instruments and meters is common knowledge to electrically trained personnel. The use of instrument switches, rheostat control, and governor motor control switches are also common; and the nameplate markings make the use of these switches obvious. Synchronizing switches are usually provided on generator and incoming line units with a synchronizing switch contact wired in series with the breaker control switch "close" contact. The synchronizing switch should always be turned "ON" first

and the circuits adjusted to be in synchronism as indicated by the synchroscope before the circuit breaker is closed.

Lamp indication is provided by a green light to indicate that the breaker is open, and a red light to indicate that the breaker is closed. For the d-c control schemes, the red light is also arranged to supervise the trip coil and indicate that the trip coil circuit has continuity.

Breaker Closing Schemes. The details of circuit breaker operating schemes may vary widely on various metal-clad switchgear assemblies; however, all control schemes are derived from the two basic schemes which will be described later in this instruction book.

Combination schemes such as closing and tripping on different voltages and schemes with a-c closing and d-c tripping are in common use. Sequence interlocking with other equipment, various arrangements of local and remote control, and automatic reclosing schemes are frequently encountered.

Figure 35 shows the two basic control schemes in their simplest form. These basic schemes comply with the requirements formulated by the AEIC which have been approved by the Triple Joint Committee of EEI, AEIC, and NEMA. A comparison between this figure and the schematic diagram for any particular metal-clad assembly will reveal which basic scheme has been employed to meet the requirements for that particular application. All of the schemes are designed to be electrically "trip-free" to co-ordinate with the mechanically "trip-free" design of the breaker mechanisms.

D-C Control. The d-c control scheme utilizes two separate relays to accomplish electrical trip-free closing of the circuit breaker. Operating the control switch to the "CLOSE" position energizes the "X" relay through a back contact of the "Y" relay and the breaker latch-checking switch. The "X" relay seals itself in around the control switch "close" contact and energizes the closing solenoid of the breaker. As the breaker mechanism nears the end of its closing stroke, the "aa" cut-off switch closes to pick-up the "Y" relay. When the "Y" relay operates, its contact in the "X" relay circuit opens to drop out the "X" relay and thus deenergizes the closing solenoid. In operating, the "Y" relay seals itself in with a contact that parallels the breaker cut-off switch. This permits the "Y" relay to remain energized as long as the control switch is held in the "CLOSE" position. "Pumping" of the circuit breaker is thus prevented in the event that the breaker trips before the control switch is released.

A-C Control. The a-c scheme for closing a breaker employs a two relay "X-Y" control panel and a Rectox to provide 125 volts d-c to the circuit breaker closing solenoid. In this scheme the "Y" relay is initially energized through the breaker latch-checking switch and a breaker "b" auxiliary switch contact. When the "Y" relay has picked up, it seals itself in through a "Y" contact paralleling the breaker "b" contact. A "Y" contact also closes in the "X" relay circuit to permit the "X" relay to be energized as soon as the control switch is operated to the "CLOSE" position. Operating the control switch to the "CLOSE" position will energize the "X" relay and will thereby cause voltage to be applied to the closing Rectox and the breaker closing solenoid. At the same time a contact of the "X" relay has been operated in parallel with the control switch "close" contact to seal up the "X" relay. As the breaker mechanism nears the end of its closing stroke, the breaker "aa" cutoff switch closes to bypass the coil of the "Y" relay and thereby to cause the "Y" relay to drop out. When the "Y" relay has been deenergized its contact opens the circuit to the "X" relay. When the "X" relay drops out its contacts open to remove power from the closing Rectox and breaker closing solenoid. When the "Y" relay drops out as previously described, a "Y" back contact closes in series with the breaker control switch closing contact so as to keep the "Y" relay deenergized as long as the control switch is held in the "CLOSE" position. "Pumping" of the breaker is thus prevented in the event that the breaker trips before the control switch is released. This same circuit also prevents "pumping" of the breaker if the a-c control source should fail due to the breaker closing on a faulted circuit.

Breaker Tripping Schemes. A variety of breaker tripping schemes are available for use with the types of control previously described.

The shunt trip coil is most frequently used with the d-c control scheme or more generally, where a reliable source of tripping power is available. A shunt trip coil is energized through the "TRIP" contact of the control switch or by the tripping contacts of any of the protective relays provided with the equipment. Normally open breaker auxiliary switch contacts are connected in series with the shunt trip coil so that the coil can only be energized when the breaker is closed. As the breaker trips, these contacts open to interrupt the trip coil current so as not to impose any current interrupting duty on the protective relay contacts. Shunt trip coils are sometimes supplied with a-c control schemes where the tripping power is derived from the same control source as the closing power. However such trip coils are only relied upon to trip the breaker under normal

OPERATION

operating conditions and are usually backed up by some additional tripping means to open the breaker should a fault occur. Shunt trip coils may also be supplied where a separate source of tripping energy such as a storage battery is available.

On schemes using a-c control where no separate reliable tripping source is available a capacitor tripping device is often employed. On this type of device a-c power is continuously supplied to a Rectox which charges a capacitor. In such cases the energy stored in the capacitor is discharged through a special trip coil when the control switch is operated to the tripping position or when one of the protective relays closes its contact to trip the breaker.

Additional tripping schemes using undervoltage release coils and transformer tripping coils are occasionally supplied. In such cases the use of these devices will be clearly indicated on the schematic diagrams supplied with the equipment.

Protective Relays. A large variety of relays may be applied to protect the system during faults or other unusual operating conditions. When such applications are made, pertinent descriptive literature on each type of relay is included in the switchgear instruction book. **Final settings of such relays should be made in the field** to co-ordinate with the other parts of the power system in accordance with the Purchaser's standards and operating practices.

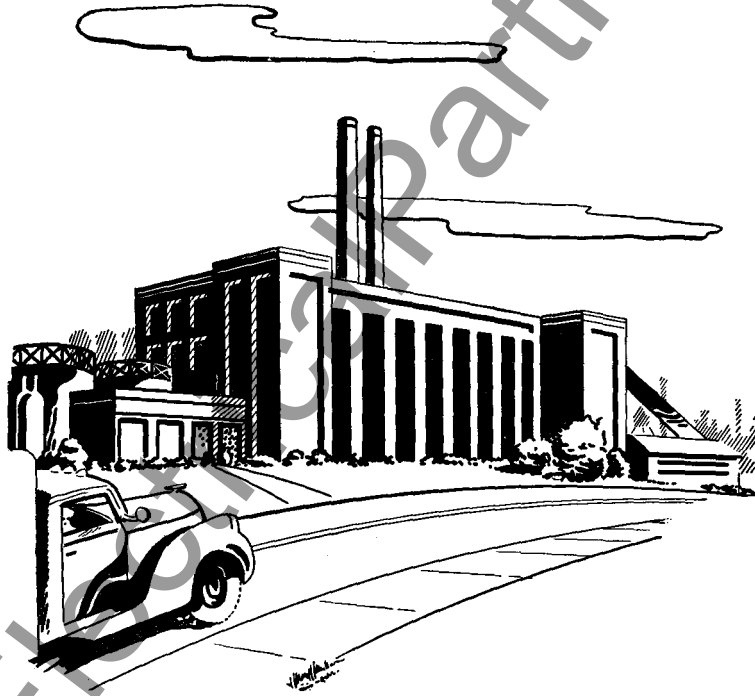

INSPECTION AND MAINTENANCE

SAFETY PRECAUTIONS

When inspecting, repairing, and performing maintenance on metal-clad switchgear the fact that dangerous voltages may exist must be kept in mind and precautions taken to insure that no personnel come in contact with a "live" high-tension part. Common general precautions for high voltage work are:

1. All connections should be considered "alive" until the men expecting to work on them assure themselves personally that the circuits are dead, and every possible precaution should be taken to see that there is no chance of a circuit being energized while the men are working.

2. Switches which have been opened to de-energize a circuit to permit work on equipment should be locked or blocked open and a suitable visible warning device placed thereon.

3. Do not work on parts normally carrying current at high voltage until these parts have been disconnected from the system and connected to the ground bus. Provision should, therefore, be made by the Purchaser for connecting adequate flexible ground leads so as to reach every part of the switching equipment.

4. A good and reliable ground connection is necessary for every switchgear installation. It should be of sufficient capacity to take care of any abnormal condition that might occur on the system and should be independent of the grounds used for any other apparatus. See Ground Bus Connections on page 31.

ACCESS TO SWITCHGEAR PARTS

Metal-clad switchgear is designed so that all high tension parts are enclosed by steel barriers and so that different portions of the circuits are in separate compartments. The design is also such that all of these compartments can be opened for inspection and maintenance by removing a few bolted covers and barriers. The general assembly section drawing has these removable covers identified by the notation "RC".

Control Equipment. The control equipment, control wiring and breaker mechanism are accessible without exposing high tension connections. On indoor switchgear this is done by opening the front instrument panel. On outdoor switchgear, opening the front weatherproof door exposes the instrument panel and control equipment, and opening the breaker side weatherproof door exposes the breaker mechanism. These panels and doors are of the latched type and may be opened without removing bolts.

High Voltage Parts. Access to current transformers and main cable connections is gained by removing the bolted cover as illustrated in Fig. 36.

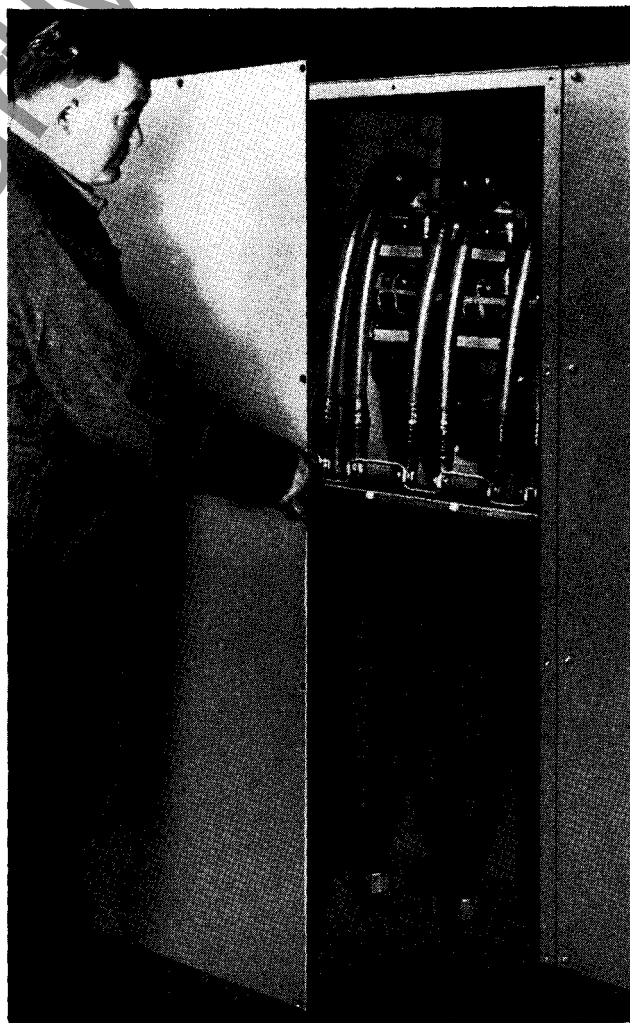

FIG. 36. Removing Rear Barrier—(For inspection of current transformers and main cable connections).

INSPECTION AND MAINTENANCE

The bus compartment is opened by removing a two section bolted barrier as shown in Fig. 37, or by removing a bolted cover in the breaker compartment after the breaker is removed.

Potential Transformers. Potential transformers are provided with disconnecting type mountings so that the transformers are disconnected and grounded automatically as the latched door of the compartment is opened as shown in Fig. 38. Access to the cables connecting the transformers to the bus or line is gained by removing covers as indicated on the general assembly section drawing.

The movable drawer of the drawout potential transformer assembly may be completely withdrawn from the compartment if necessary for repairs.

To completely remove the drawer, open the door, disconnect the operating links from the door clips and pull the drawer out.

Breaker Contacts. The breaker contacts are exposed for inspection and maintenance by removing the interphase barrier and arc chutes as shown in Figs. 39 and 40. For the 5 kv breakers the barriers are all in one assembly, while for the larger 7.5 kv and 15 kv breakers the barriers, as

shown in Fig. 41, are arranged in two sections to facilitate handling. The arc interrupting chutes are released by removing the strap bolted to the magnet frames and the shunt to the lower main contact. The chutes should be handled carefully to avoid breaking any of the ceramic parts. Additional information on the breaker inspection and maintenance will be found in the instruction book covering the particular rating of breaker supplied with the metal-clad switchgear.

MAINTENANCE SCHEDULE

In order to assure the high quality service for which the switchgear has been designed, a definite maintenance schedule, systematically followed, is essential. Plant, operating, and local conditions vary to such an extent that the actual schedule must be prepared to suit the local conditions. However, the following general requirements should be helpful in setting up the necessary program.

The maintenance schedule for individual devices such as circuit breakers, relays, meters, etc. should be based upon recommendations contained in the individual instruction book for the device. These operations should be coordinated with the overall

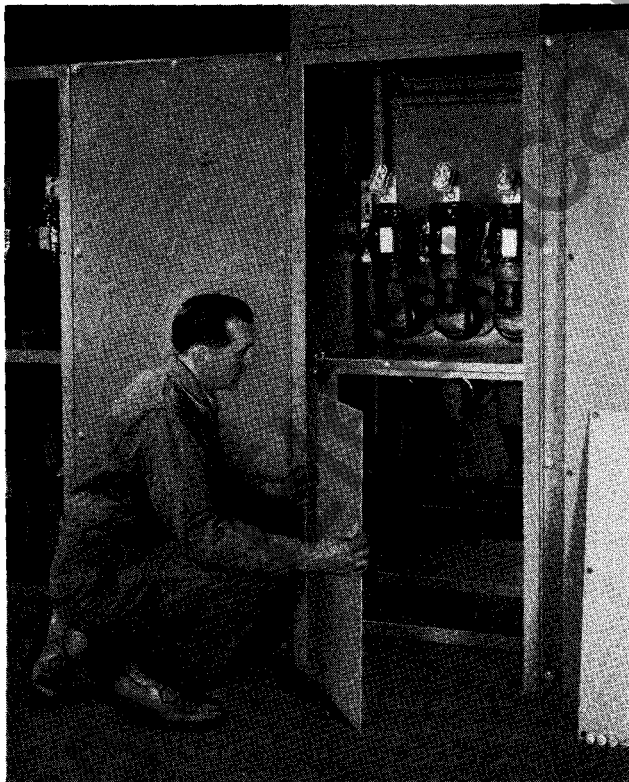

FIG. 37. Removing Barriers of Main Bus Compartment. (Busses are also accessible from breaker side of housing by removing bolted section of barrier).

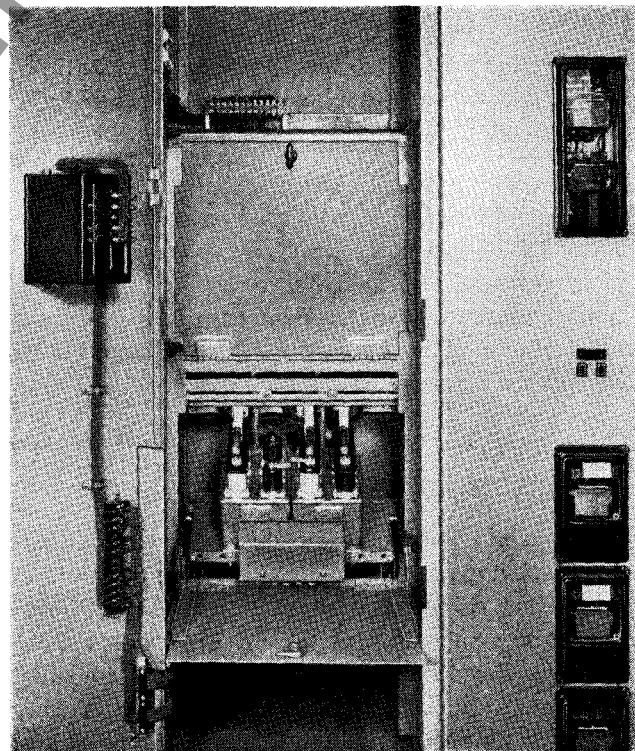

FIG. 38. Access to Potential Transformers. (Disconnecting type arrangement disconnects both primary and secondary and grounds primary when door is opened for access to fuses).

program to result in the least operating inconvenience and circuit shut-down.

The switchgear installation should be given a thorough overall maintenance check at least annually, when operating conditions are normal. Where operating or atmospheric conditions are abnormal, more frequent inspection and maintenance is necessary. The following items require attention.

1. Busses and Connections. Deenergize the primary circuits and remove all cover plates from the primary compartments. Inspect for abnormal conditions which might indicate overheating or weakened insulation. Remove dust accumulations from bus supports and enclosure surfaces. Use a vacuum cleaner with a long nozzle to assist in this work. Wipe all busses and supports clean with cloths moistened in a cleaning solution such as Stoddard's Solvent (Westinghouse No. 1609, a petroleum hydrocarbon solvent).

CAUTION—*This is a flammable liquid having a flash point of 100°F. Keep sparks and flames away. Do not breath large quantities of vapor. Avoid continuous or excess contact with the skin.*

After busses have been dusted and wiped clean, take "megger" readings between the busses and

ground and between phases. Keep a record of these readings for future reference in determining when trends occur that would indicate a lowering of the insulation resistance.

Periodic high potential tests are not required and are recommended only after repair of high voltage busses or insulation, or when the trend of megger readings indicates it to be advisable. Such a high voltage test should not exceed 75% of the factory test values given in AIEE Standard No. 27 for new switchgear. Potential transformer primary fuses should be removed during high potential tests.

2. Primary and Secondary Disconnecting Contacts. Each breaker should be removed from its housing for inspection of the primary and secondary disconnecting contacts and their supporting insulation. Wipe clean with a cloth moistened in Stoddard's Solvent. (See preceding paragraph). Inspect for abnormal wear or overheating. Discoloration of the surfaces is not harmful unless corrosion due to atmospheric conditions is severe, leaving deposits on the surface. If necessary, these can be removed by a light application of crocus cloth. Apply a thin film of vaseline to all contacts before replacing the breaker. Check each breaker while it is out of the housing for all items recommended in the instruction book applying to that particular type of breaker.

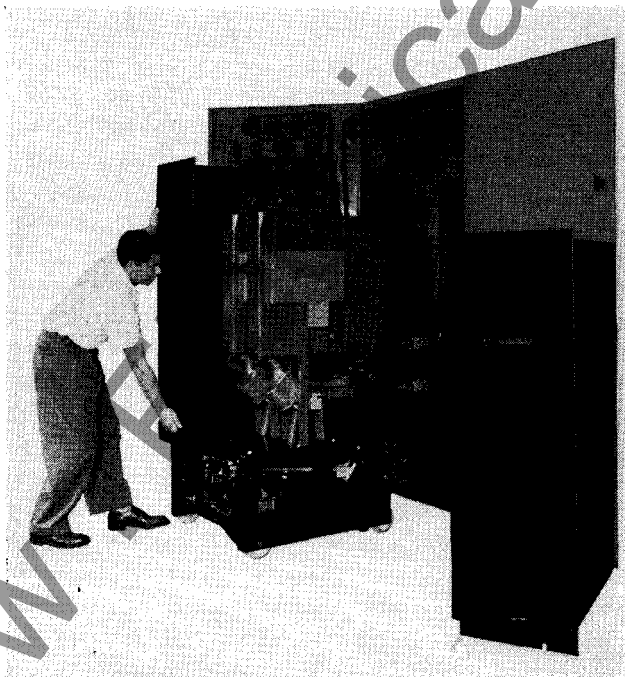

FIG. 39. Removing Interphase Barrier. (Loosen holding bolts and slide barrier forward to expose arc chutes).

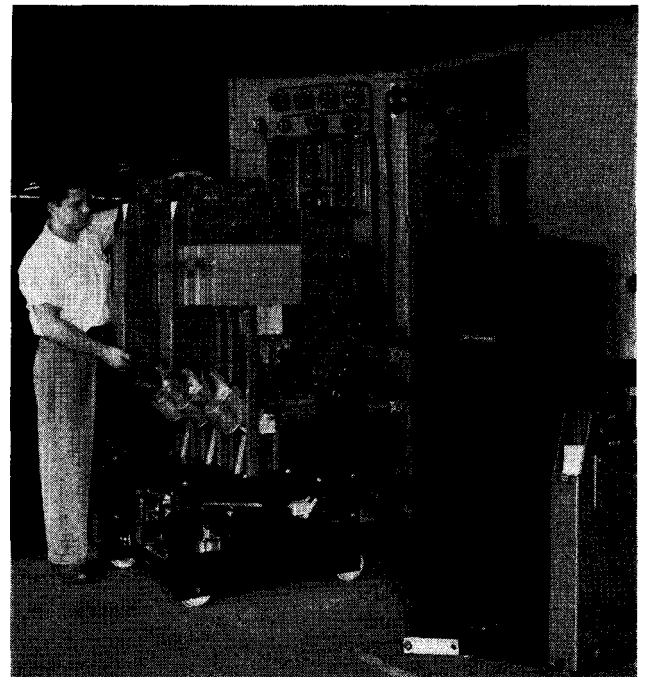

FIG. 40. Removing Arc Chutes. (A few accessible bolts clamp the chutes in place and connect the shunt to the arcing contact).

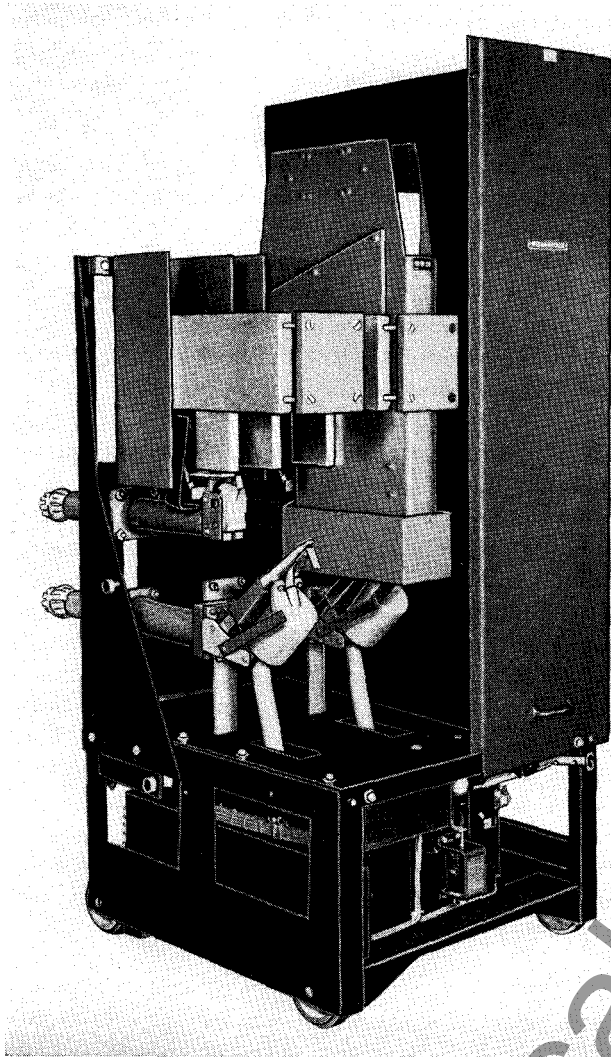

FIG. 41. 15 KV Type "DH" Breaker. (Showing one half-section of barrier and one arc chute removed).

3. Levering Device and Shutter. These devices should be cleaned, a few drops of oil applied to bearings, and a thin film of grease to guide surfaces, racks, screws and bolt threads. The application should be thorough, but not excessive, to prevent the accumulations of dust and dirt.

4. Control Relays. Contacts should be inspected and dressed or replaced when the surface becomes seriously pitted. Unless repetitive duty has been experienced, little attention should be required.

5. Instruments, Relays and Other Panel Mounted Devices. Individual devices should be maintained according to the specific instructions supplied for each device. Remove all relay covers and inspect the interiors for dust or dirt. This operation can most readily be performed by relay test

personnel during periodic relay tests. Control switches, transfer switches, and instrument switches should have their contacts inspected and dressed when necessary.

6. Dust Filters. Check all dust filters for excessive accumulation of dust and dirt and replace them as necessary.

7. Secondary Wiring. Check all wiring connections for tightness including those at the current and potential transformers and at the terminal blocks where circuits leave the switchgear. Make sure that all secondary wiring connections are properly connected to the switchgear ground bus where so indicated.

8. Battery and Charging Equipment. The control battery is such an important item in switchgear operation that it must be given special periodic attention if it is to have a long life of reliable service. Periodic inspections and tests are recommended in the battery supplier's instructions. At the same time the battery is checked, inspect the battery charger and remove accumulations of dust and dirt. On all chargers having a manual transfer switch for setting the charging rate, check carefully to be sure that the selector switch is returned to the value appropriate for a floating charge at the end of the periodic inspection. Serious damage to the control battery can occur if the charger is left on a high charging rate for an extended period of time.

9. Records. The condition of each switchgear unit at the time of inspection should be listed in a permanent record to become a guide for anticipating the need for replacements or for special attention between the regular maintenance periods. Megger tests are suggested for checking the insulation. A series of these tests will indicate any tendency toward a reduction in dielectric strength of the insulation. Megger readings should be taken before and after cleaning the equipment and, insofar as possible, under similar conditions at successive periods. Records should include the megger reading, the temperature and the humidity (either by definite reading or description). These limits will vary with the extent and design of the bus structure. In contrast with a small installation, the longer switchgear assemblies will have a more extensive bus structure with a greater number of insulators and, thereby, a larger number of parallel insulation resistance paths to ground which will tend to decrease megger readings. This variation in insulation resistance between different switchgear assemblies emphasises the value on a series of readings which

can be charted to establish a normal insulation level so that progressive weakening of the insulation can be recognized.

10. Abnormal Conditions. Local conditions; such as, high humidity, salt-laden atmosphere, corrosive gases, heavy dust, or severe circuit operating conditions, are considered to be abnormal; and will require more frequent inspections.

It should be emphasized that a series of inspections should be made at quarterly intervals until the progressive facts of the local conditions can be analyzed to determine a schedule which will maintain the equipment in satisfactory condition.

11. In some locations local conditions may be so bad that the frequency of maintenance will interfere with operating and production schedules. In such cases, consideration should be given to the possibility of enclosing the switchgear equipment in a relatively tight room and to supplying a sufficient quantity of clean air so as to maintain a positive pressure in the room. Under such conditions maintenance schedules may then be established on a more normal basis. Such an arrangement might also provide for cooling the air where the ambient temperature is relatively high, thus further improving operating conditions.

LUBRICATION

The worm and gear type levering device on the horizontal draw-out switchgear should be lubricated periodically to insure free and easy operation. A semi-fluid grease of consistency similar to 600-W, sufficiently heavy to remain in place for a long period of time and at the same time not channel, is most suitable for this purpose.

A lighter type of oil can be used on the various shaft bearings, the levering-in device, and disconnecting switch shafts and any other bearing points to promote ease and smoothness of operation.

The bearings or sliding parts of any interlocking arrangement supplied with disconnecting switches or special arrangements of breaker interlocking should be lubricated occasionally with a light oil. Never oil the cylinder of Yale, Corbin, or similar locks.

The operating mechanism of the shutters for the horizontal draw-out type equipment should be lubricated occasionally with a light oil at all pivot points. The guide ways or slots on these assemblies can also be lubricated to good advantage.

RENEWAL PARTS

The convenience and advantage that may be gained by carrying in stock a few well chosen, comparatively inexpensive renewal parts, is so great that the advisability of so doing cannot be over emphasized. In spite of the care which may be exercised, it is inevitable that at some time a vital part, such as a main disconnecting contact, will become damaged beyond use—possibly causing delay at a very inopportune time.

The following parts are suggested as spares for a typical layout although recommendations may vary for particular installations:

Recommended Stock of Renewal Parts

- 1—Set of circuit breaker parts for each type of breaker, consisting of:
 - 1—Set of arcing contacts
 - 1—Main disconnecting contact assembly
 - 1—Shunt trip coil
 - 1—Lift or pull rod
- 1—Set primary fuses for potential transformers
- 1—Standard package of indicating lamps and secondary fuses
- 1—Lot of fingers and segments for control, instrument, and auxiliary switches.
- 1—Set of contacts and coil for each type of auxiliary or control relay.

These renewal parts should be ordered as soon as possible if not ordered at the time that the initial equipment was purchased. They will then be available during the installation period, should any mishap occur, and prompt ordering may avoid delay in obtaining parts after a breakdown.

Instructions for Ordering. When ordering renewal parts, give the nameplate reading, the name of the part wanted, and the shop order number of the apparatus on which the part is to be used. Refer to the back cover of this book for the nearest District Office from which to order parts.

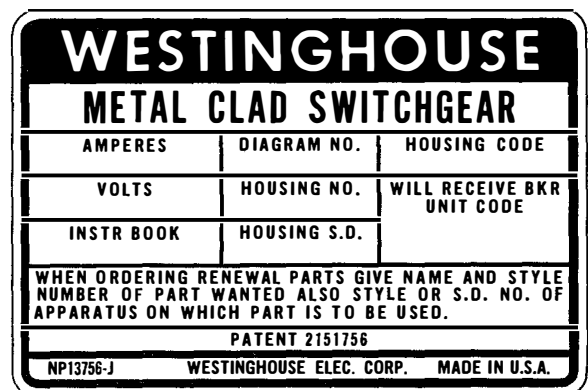

FIG. 42. Facsimile of Housing Nameplate.

MEMORANDA

www.ElectricalPartManuals.com

MEMORANDA

www.ElectricalPartManuals.com

www.ElectricalPartManuals.com



RECOMMENDED MAINTENANCE FOR ORGANIC INSULATION IN HIGH VOLTAGE AIR CIRCUIT BREAKERS

Organic insulating materials are used in high voltage air circuit breakers for pole unit supports, operating rods, barriers, braces, arc chutes and similar purposes, where it has been found to be more suitable than porcelain. The material used on Westinghouse breakers is Micarta, which has a long established record for insulating and mechanical dependability. To ensure long continued electrical resistance, the Micarta surface is protected with high grade insulating varnish which may be either clear or pigmented, depending on the place of use and the apparatus design requirements. The purpose of the varnish is to retard moisture absorption and to provide an easily cleaned surface. Like all other insulating surfaces, whether organic or inorganic, a varnished Micarta surface should receive periodic attention in order to maintain the insulation resistance at the highest possible value.

The objects of maintenance are two-fold first to remove dust and other foreign air borne materials as well as chemical oxides which result from aging of the varnish, and second to make sure that the varnish provides a continuous protective film over the entire insulating surface.

After breakers have been in service for three to five years, the insulation should be inspected, cleaned, and the varnish renewed if the surface indicates it to be needed.

While the surface of the insulation is dry, contamination does not usually cause any large change in insulation value. However, if while it is present, moisture is added in the form of condensation, or by more direct means, the surface electrical leakage may be greatly increased, even to the point of electrical breakdown. The first object of maintenance therefore is cleaning. A clean varnished surface will be smooth, glossy, and free from foreign material either loose or adhering to the surface. To obtain a clean surface, it is

necessary to loosen the adhesive dirt by scrubbing and washing. This is best accomplished in the following manner:

1. Wash with normal heptane, obtainable from the major oil companies such as Esso Standard. Use clean paper towels wet in the heptane. Use a fresh towel on each part.

CAUTION: HEPTANE IS INFLAMMABLE AND NO OPEN FLAMES OR SPARKS SHOULD BE ALLOWED NEAR THE WORK.

2. After the heptane has evaporated, which requires only a minute or two, wash with de-ionized water, sometimes called demineralized water, or distilled water.

NOTE: De-ionized or demineralized water can be obtained in small quantities from many firms that maintain chemical laboratories, particularly storage battery manufacturers or electroplaters.

Use fresh paper towels and keep the water in a handy size glass bottle. Wet the towel from the bottle, wash the part and dry immediately with a fresh towel. Use fresh towels for each part.

In inspecting the insulating parts preparatory to cleaning, wipe off superficial dirt with a dry cloth and note the condition of the varnish and of the Micarta. If the varnish appears in good condition, i. e., fairly smooth and with liberal coverage, proceed with cleaning.

If the varnish appears thin, and is not uniform in coverage, is cracked or can be peeled off with the fingernail, the parts should be revarnished.

This can be done with the parts in position on the breaker, as follows:

1. Sandpaper when needed to remove loose varnish and wipe off all dust from sanding.

2. Apply three coats of varnish, Westinghouse M#135A or M#7623-1. Allow 24 hours drying time between coats at ordinary temperatures. Drying time may be decreased by preheating parts with infrared lamps to a temperature of 40 to 50 degrees C before applying varnish and likewise heating each coat for about 4 to 8 hours, or until the varnish has set up to the point where it will not be lifted by applying the succeeding coat.

Resin bonded laminated insulating materials are formed under pressure at high temperature. The release of pressure, reduction of temperature and some further shrinking of the resin bond produces internal stresses. Relieving of these stresses may result in the formation of minute cracks or checks along the laminated edges of the insulation. Such cracks, if small, are sealed by the varnish and are not harmful.