



RECEIVING • INSTALLATION • MAINTENANCE  
**INSTRUCTIONS**

**De-ion<sup>®</sup>**  
**AIR CIRCUIT BREAKER**  
**Type 50-DH-75**

**WESTINGHOUSE ELECTRIC CORPORATION**  
SWITCHGEAR DIVISION

**EAST PITTSBURGH PLANT**

**EAST PITTSBURGH, PA.**

SUPERSEDES I.B. 32-251-1

DECEMBER, 1956

<sup>®</sup>Trade-Mark

Printed in U.S.A.

# TABLE OF CONTENTS

<b>DESCRIPTION</b>	<b>Pages 3</b>
Description .....	3
<b>RECEIVING, HANDLING AND STORING</b> <b>Pages 3-5</b>	
Receiving .....	3
Handling .....	3
Storing .....	5
<b>INSTALLATION</b> <b>Pages 5, 6</b>	
Installation .....	5,6
<b>OPERATION</b> <b>Page 7</b>	
Operation .....	7
<b>OPERATING MECHANISM</b> <b>Pages 7-12</b>	
Puffer Assembly .....	7
Mechanism Mounting Plate .....	7
Shunt Trip Manget .....	7
Cut-off Switch .....	7
Latch Check Switch .....	9
Operation Counter .....	9
Undervoltage Trip Attachment .....	9
Three Coil Trip Attachment .....	9-10
Arc Chute .....	10-12
Levering-In Device .....	12
Test Position .....	12
Mechanical Interlock .....	12
Secondary Contacts .....	12
<b>MECHANISM ADJUSTMENTS</b> <b>Page 13</b>	
Mechanism .....	13
Cut-off Switch .....	13
Latch Check Switch .....	13
Operation Counter .....	13
<b>MAINTENANCE</b> <b>Pages 13-19</b>	
Arc Chutes .....	14
Broken or Cracked Ceramic Parts .....	14
Erosion of Ceramics .....	14
Dirt in the Arc Chute .....	14
Cleaning the Arc Shields .....	14,15
Contacts .....	15
Organic Insulation .....	15,16
Cleaning .....	16,17
Inspection .....	17
Varnishing .....	17
Parts Identification and Renewal .....	17
Pole Unit .....	18
Arc Chute .....	18,19
Renewal Parts .....	19

## DESCRIPTION

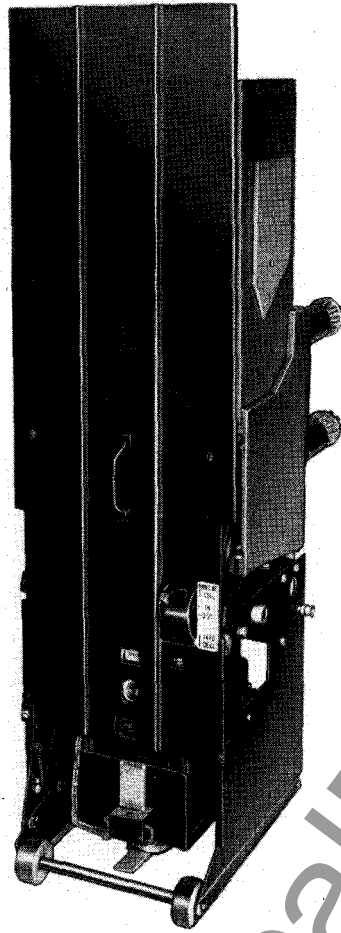

FIG. 1. Type 50-DH-75 Breaker  
Completely Assembled

The Type 50-DH-75 air circuit breaker is a 3-pole, 1200 ampere, electrically operated, horizontal draw-out unit for metal clad switchgear. The breaker is designed to operate on a-c circuits of 2300 to 4160 volts nominal, and 4760 volts maximum. The interrupting rating is 75,000 KVA in the 4160 volt range, and 50,000 KVA at 2300 volts. This corresponds to 10,400 amperes interrupting rating at 4160 volts, and 12,500 amperes at 2300 volts. For other rating information refer to the Westinghouse Descriptive Bulletin 32-251.

Figure 1 shows a Type 50-DH-75 breaker completely assembled. Figure 2 shows the same breaker with the front barrier and the center pole shield removed; and one arc chute tilted back. This also shows the combined arrangement of the blowout magnet and the arc chute, the contacts, the insulated operating rods, and the solenoid operating mechanism. These parts are supported on the chassis having flanged wheels for guiding it into the metal-clad cell. At the front of the chassis is the levering-in device for engaging the breaker into and out of the cell. The levering-in device is also interlocked with the solenoid mechanism to prevent the breaker being placed into or out of the cell with the breaker contacts in the closed position. The chassis also contains the secondary control cable contacts, auxiliary switch, puffer assembly, and shunt trip assembly for the standard breaker. Special breakers may include undervoltage and current transformer tripping devices.

The center pole insulating shield is slipped into place and the dead front barrier is placed on the breaker before it is rolled into the cell. The front barrier is of one-eighth inch steel to form a grounded barrier between the personnel and the live parts of the breaker when placed in the cell cubicle.

## RECEIVING HANDLING AND STORING

### RECEIVING

All Type 50-DH-75 breakers are given operating tests at the factory, after which they are carefully inspected and prepared for shipment by shippers experienced in the proper handling and packing of the electrical equipment. The breaker is shipped in a single crate as a completely assembled package including the required number of manual operating handles as required by the order. The

center insulating barrier is removed from the center pole to facilitate packing. After unpacking, the barrier should be placed over the center pole arc chute until it rests on the pole unit base. After the equipment has been unpacked, make a careful inspection for any damage which may have occurred in transit. If the apparatus has been damaged, file a claim immediately with the carrier and notify the nearest Westinghouse Sales Office.

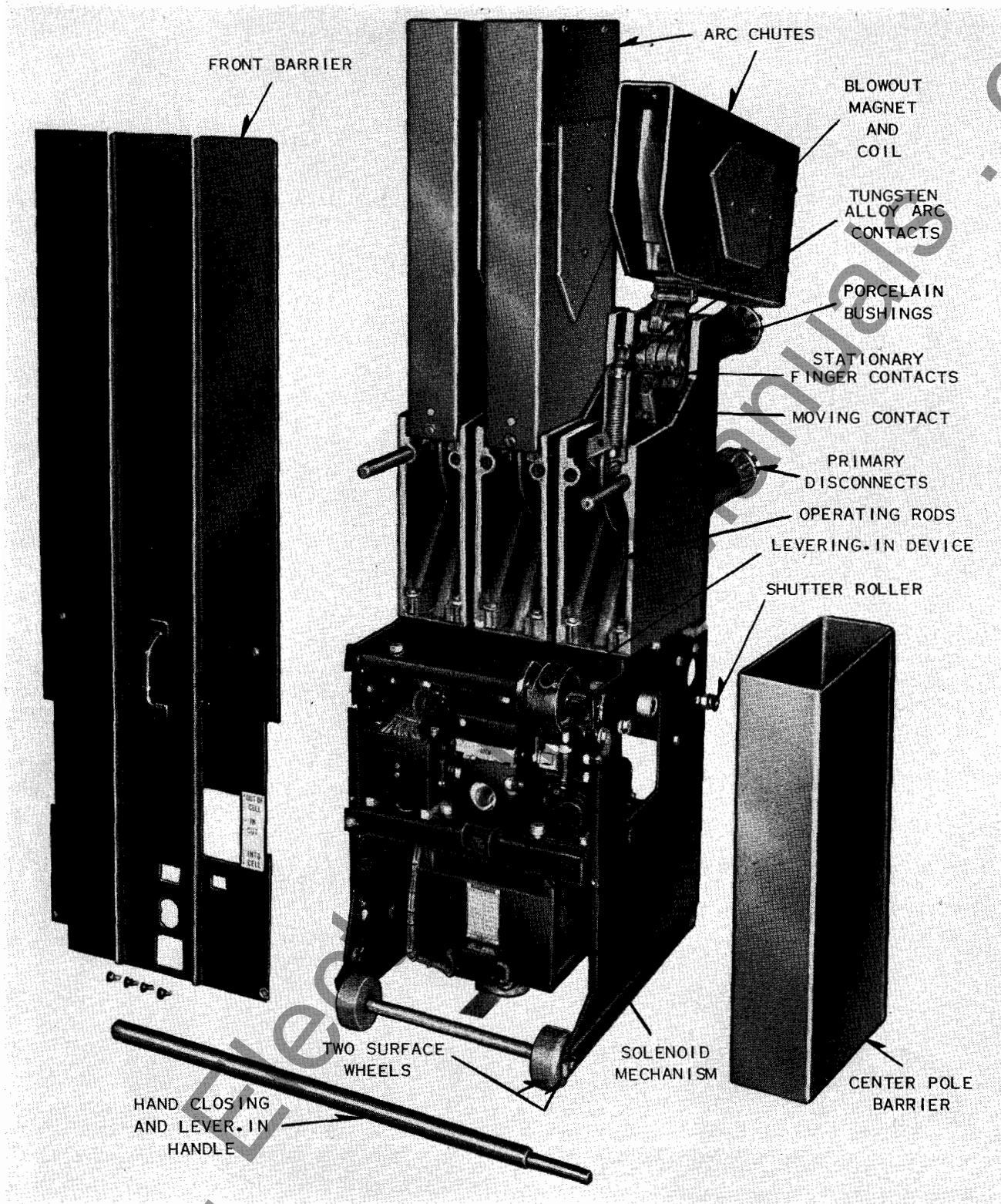

FIG. 2. Type 50-DH-75 Breaker with Front Barrier and Center Pole Barrier Removed

### HANDLING

Remove the crating and packing carefully to avoid damage from rough handling of crow bars or other tools. Use a nail puller for the uncrating but first remove the 1/2 inch bolt which fastens both sides of the breaker to the crate cross members. Care must be used in handling the assembly since the arc chute splitter plates are made of ceramic material which may break with rough handling.

The base of the crate may be used as a skid for moving the breaker, or the breaker may be lifted with slings placed under the crate. If the breaker is to be lifted with slings, move it while it is still crated. After the breaker is unpacked, the breaker may be moved about on its own wheels.

If it is necessary to lift the breaker after it is uncrated, four lifting holes are provided in the frame for this purpose. Use a spreader to prevent the cable from distorting the pole unit channel bases.

The approximate weight of a complete three pole breaker is 500 pounds. The arc chutes each weigh 40 pounds, the front steel barrier weighs 30 pounds,

and the breaker without the arc chutes and barrier weighs approximately 350 pounds.

### STORING

Since the breaker is shipped completely assembled, it should be stored in a dry place, sufficiently warm to prevent condensation and absorption of moisture. The assembly should be protected from the accumulation of dust by placing a protective covering of paper or other sheltering material to properly protect the insulating surfaces. Before placing the stored units in service, a careful check should be made of the cleanliness of the insulating surfaces, and any foreign materials that may have accumulated in the arc chute proper should be removed. Stored units subjected to abnormal conditions should pass a potential test of approximately 15,000 volts for one minute between live parts and ground.

Store all components for this breaker in a clean dry place. During the storage period, keep them in a sufficiently warm atmosphere to prevent moisture condensation.

## INSTALLATION

### INSTALLATION

With the exception of the center pole shield, this breaker is shipped completely assembled and adjusted. No adjustment should be required and none should be made unless it appears necessary to do so.

**Caution:** Severe injury may be sustained if any part of the body is struck by the contact arms since they move very rapidly on the opening stroke. Personnel working about the breaker should stay clear of the space in which the contact arms move while the breaker is closed or is being closed. If the breaker has been closed by hand, always remove the hand closing lever before tripping the breaker.

The following sequence of operations should be performed in preparing the breaker for use:

1. After the breaker is unpacked and the shipping ties and braces removed, disconnect the front arc horn bolt and tilt each arc chute back as shown in Figure 2. Then close the breaker carefully by hand using the hand closing lever. Make certain that all parts are functioning properly and that there is no binding or excessive friction. As the contacts touch near the end of the closing stroke, the force necessary to close the breaker increases rapidly.

2. With the breaker in the closed position, check the contacts to make certain that the adjustments have not been disturbed. The main contact over-travel should not be less than the 1/8 inch as illustrated in Figure 3B. Trip the breaker, and close it again by hand until the arcing contacts just touch. The main contact surfaces should be separated by 3/8 plus or minus 1/32 as illustrated in Figure 3A. If adjustments are required, they should be made as described in Figure 3.

A light film of grease is applied to both the arcing and main contacts before the breaker is operated at the factory. This film is normally removed before shipment. Before the breaker is placed in service, inspect all contacts to see that they are dry and free of any oil or grease.

3. Before placing the breaker in service, play a stream of dry compressed air through the arc chutes from each end to remove any dust or foreign matter. Then examine the arc chutes to make certain that the vents end slots are open and free from foreign material.

4. Return the arc chute to the normal position, connect the copper strap connection at the front tightly. Next replace the center pole insulating

## INSTALLATION

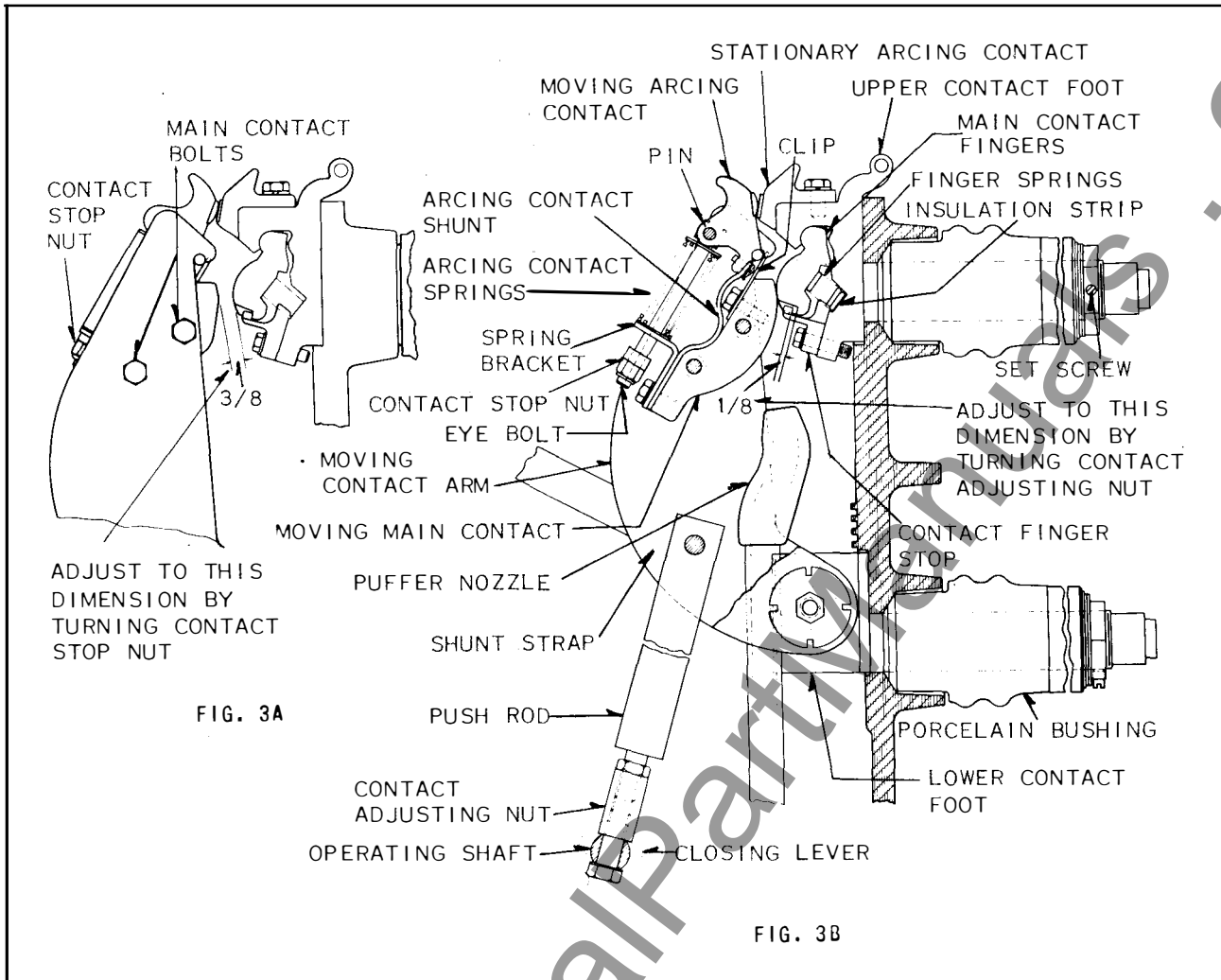

FIG. 3. Pole Unit Assembly

barrier, and then the front steel barrier if it has been removed.

5. Make a final check by operating the breaker slowly by hand to see that there is no interference in the free movement of the moving contact.

6. The breaker is now ready to be operated electrically. Each breaker should be closed and tripped electrically several times before being connected to the high voltage. These operations may be made at the *test position* in the cell or by other test facilities that may be available. The hand closing lever must always be removed from the socket before operating the breaker electrically. If the electrical operation is fast and positive on the closing and opening operations, the breaker is now ready to be levered-in to the operating position.

**Caution:** Do not attempt to close the breaker by hand against an energized circuit. To insure sufficient closing force and speed, the breaker should be closed electrically from an adequate power source. See NEMA Standard SG 4-510.

When the breaker is placed into the cell and moved beyond the test position, the high voltage parts of the breaker will be energized. The front steel barrier should always be assembled on the breaker, for then personnel will be protected from contacting the live parts. The breaker should never be placed into an energized cell structure beyond the test position without first having the breaker completely assembled with the arc chutes, the center phase insulating barrier, and the front steel barrier.

# OPERATION

Before operating the circuit breaker, it is important to become familiar with the structure and function of the various parts. The following paragraphs describe the operation of the breaker.

The general arrangement of the breaker parts is shown in Figures 3 and 4. The solenoid coil is arranged to exert an upward force on the mechanically trip-free linkage. This linkage, in turn, exerts an upward force on the pole unit operating rods which move to close the breaker. The moving contact arms contain the main contacts and arcing contacts. On opening, main contacts first separate

apart followed after a short travel, by the opening of the arc contacts. On closing, they touch in the reverse order. The arc contacts touch first followed by the closing of the main contacts. At the terminal ends of the bushing are clusters of finger contacts for engaging the power circuit contacts in the cell. Located directly above the arcing contacts are the arc chute assemblies.

The breaker is tripped manually by pushing the "Push To Trip" button at the front of the breaker mechanism, or tripped electrically by energizing the trip coil with the control source of power.

## OPERATING MECHANISM

The operating mechanism with its trip-free linkage is shown in Figure 4. The vertical lift action of the closing solenoid core is transmitted to the pole unit push rods through a system of links directly connected to the solenoid. The lever system consists of four major links; the first link, the second link, the third link, and the closing lever. These members are arranged as shown in the Figure 4 and are held to form a rigid member by the tension link and the cam. The cam is held in the fixed position by the tripping latch.

When the closing solenoid is energized, it pushes on the junction of the first and second toggle links causing the closing lever to rotate about its fixed center. The closing lever then exerts an upward force on the push rods through the moving contacts to close the breaker. The breaker is then held in this position by the tripping latch and the pawl.

The breaker is tripped electrically or manually by rotating the tripping bar which disengages the primary latch. This allows the roller latch assembly to release the tripping latch which in turn releases the tripping cam so that it is free to rotate. Without the restraining force of the cam and the tension link, the major links 2 and 3 collapse under the combined pushing force of the contact springs, and the accelerating springs which are assembled over the puffer push rods. Included in the operating mechanism is the position indicator. It gives a direct visual indication that the breaker contacts are either in the open or closed position.

### PUFFER ASSEMBLY

Directly behind the mechanism is a puffer arrangement that supplies a jet of air to each set of contacts through an insulating tube and nozzle. Since the blowout force of small currents is very light, the jet of air is released at the instant the breaker is tripped. The arrangement is illustrated in Figure 5, and should require no maintenance. The diaphragm is connected to the operating mechanism through the two operating rods, which also contain accelerating springs that help accelerate the contacts to the open position. To remove the puffer tube and nozzle, the set screw should first be loosened and the nozzle tube may then be drawn from the top side of the breaker. The diaphragm is made of long lasting wide temperature range material and should never require replacement unless through accidental puncturing. If replacement is necessary, remove the clamping ring and the bolted clamp plate. Add the new diaphragm in a relaxed position *without* gasket cement, then tighten the bolts around the clamp uniformly with moderate uniform pressure.

### MECHANISM MOUNTING PLATE

The mechanism mounting plate is located between the truck side frames. On it are mounted the operating mechanism, closing solenoid, and the following auxiliary devices included as standard on all breakers:

**OPERATING MECHANISM**

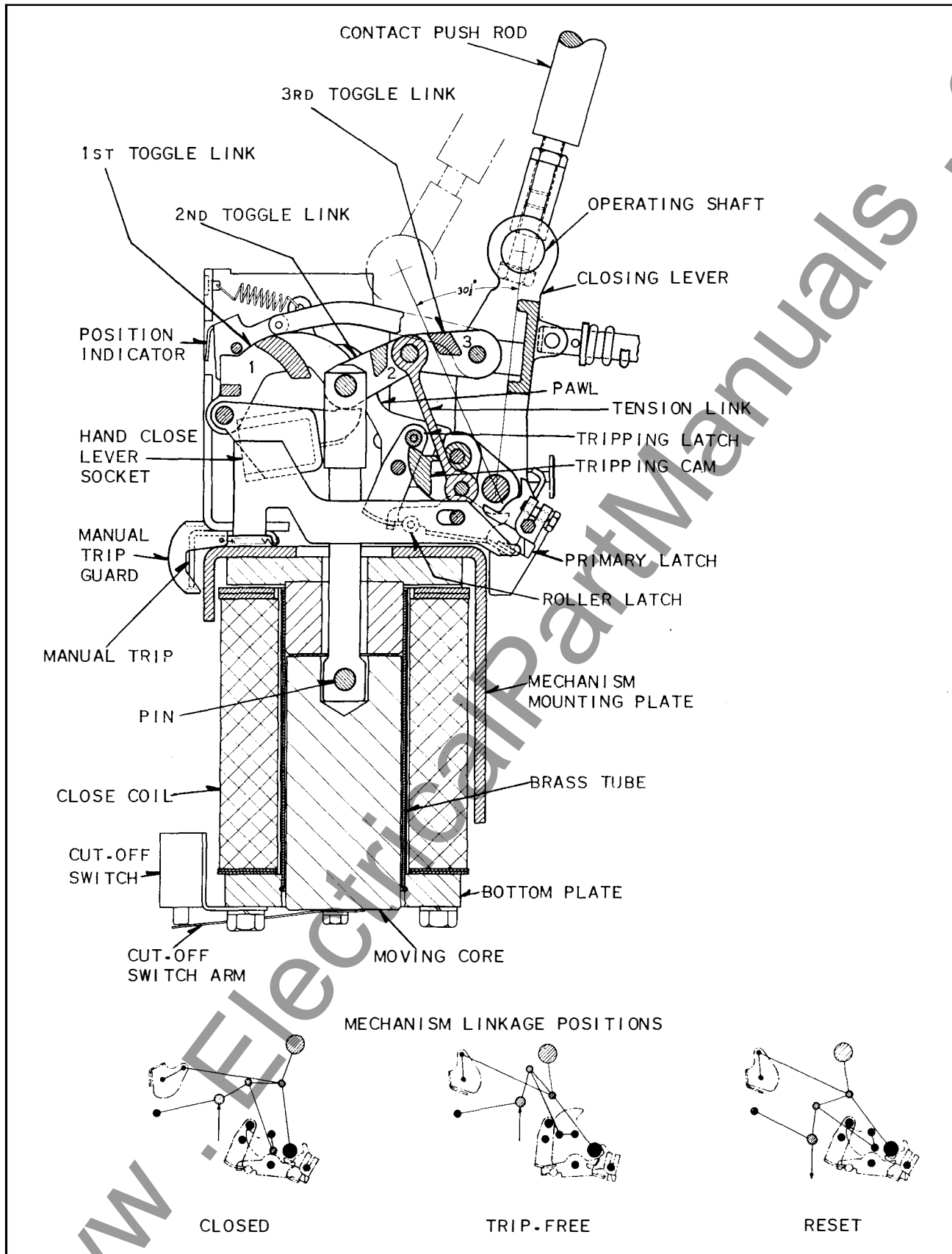

**FIG. 4. Solenoid Operating Mechanism**

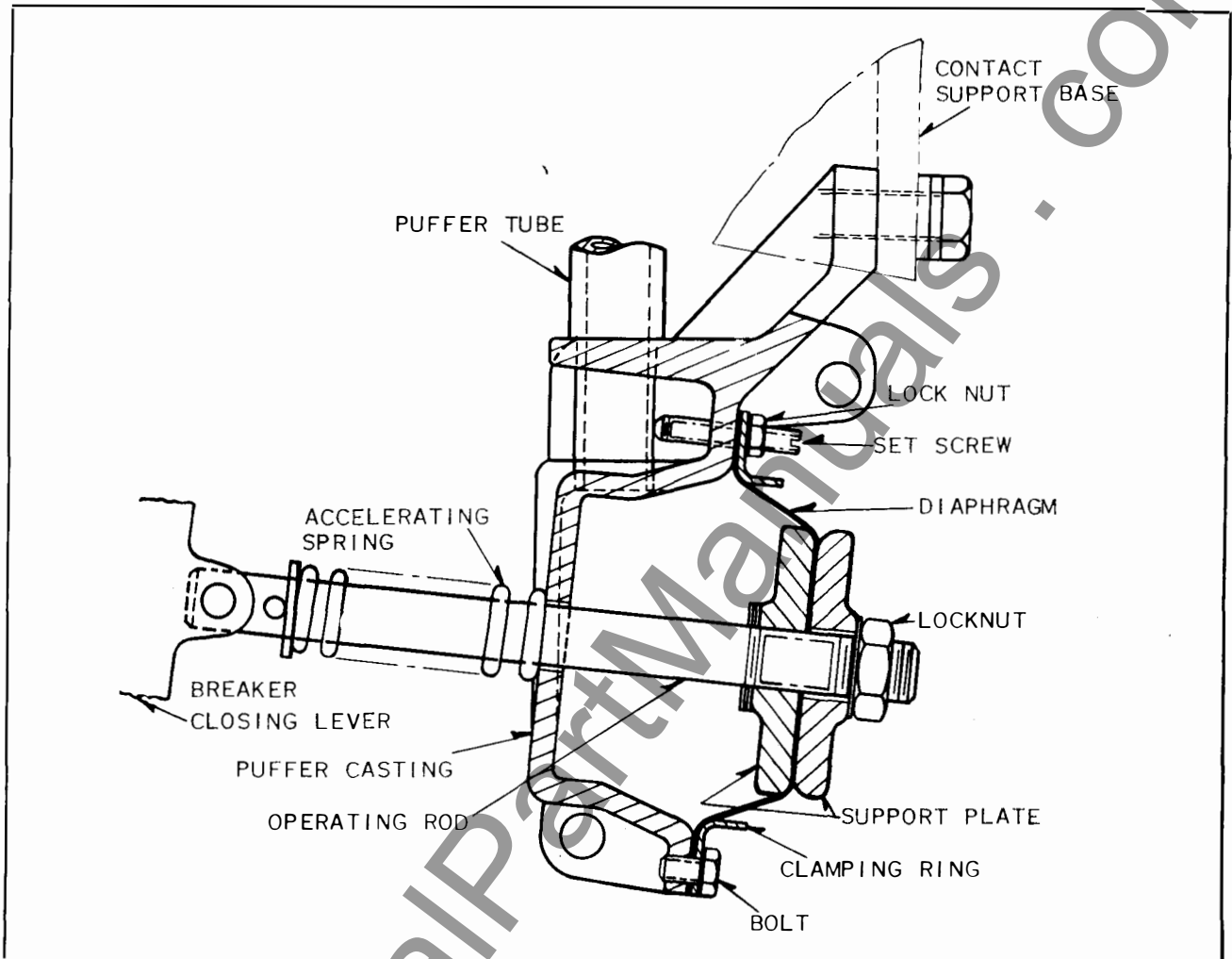

FIG. 5. Puffer Assembly

**Shunt Trip Magnet.** This device is used to trip the breaker electrically. It may be equipped with a coil for direct current or alternating current or capacitor tripping power source.

**Cut-Off Switch.** This switch controls the power to the closing solenoid which is cut off after the breaker reaches the closed position.

**Latch Check Switch.** The latch check switch is mounted directly above the shunt trip assembly. It is connected to the secondary contact block, in accordance with the wiring diagram supplied with the apparatus. If the breaker is used for automatic reclosing duty, it is necessary to arrange the electrical control so that the closing circuit will not be established until the breaker has completely re-set after the tripping operation. This sequence is controlled by the latch check switch. The switch remains closed at all times except from the instant the primary latch is tripped and until the linkage has completely

reset. During this short period of time, the latch check switch circuit is open and prevents the closing circuit from being established.

**Operation Counter.** This counter records each operation of the breaker.

The following devices may also be mounted on the breaker as specified by the Customer's requirements:

**Undervoltage Trip Attachment.** The device is illustrated in Figure 5.1, and it is located at the right side of the closing mechanism mounting plate. This is a magnetically held device which when de-energized will trip the breaker using the force stored in a spring during the breaker's previous opening stroke. For instantaneous release, the holding magnet coil may be directly connected to a d-c control source, or it may be supplied with a low voltage d-c obtained from an a-c control voltage through a

## OPERATING MECHANISM

small transformer and rectox assembly mounted in the cell structure. For time delay release on tripping, an undervoltage time delay attachment Figure 5.2, is mounted on the undervoltage trip assembly. This is an air dash-pot device, and the controlled flow of air through a needle valve gives the required time delay. The attachment does not have a quick reset feature, and therefore, approximately 1 minute should be allowed between operations to permit complete resetting.

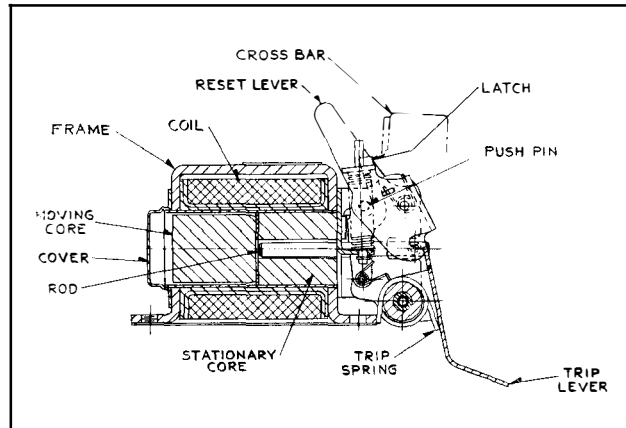

FIG. 5.1. Undervoltage Trip Unit

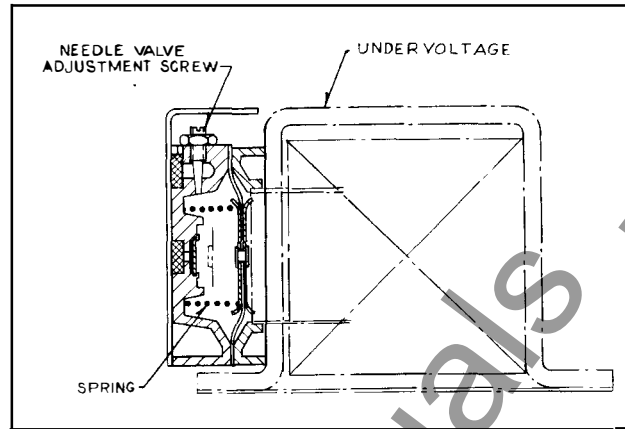

FIG. 5.2. Undervoltage Time Delay

**Three Coil Trip Attachment.** The three coil current trip attachment, when supplied, mounts at the rear of the mechanism mounting plate and is used in addition to the shunt trip magnet. It is designed to accommodate three instantaneous current transformer trip assemblies. The calibration on each of the current trip coils is engraved with the values of current required to trip the breaker.

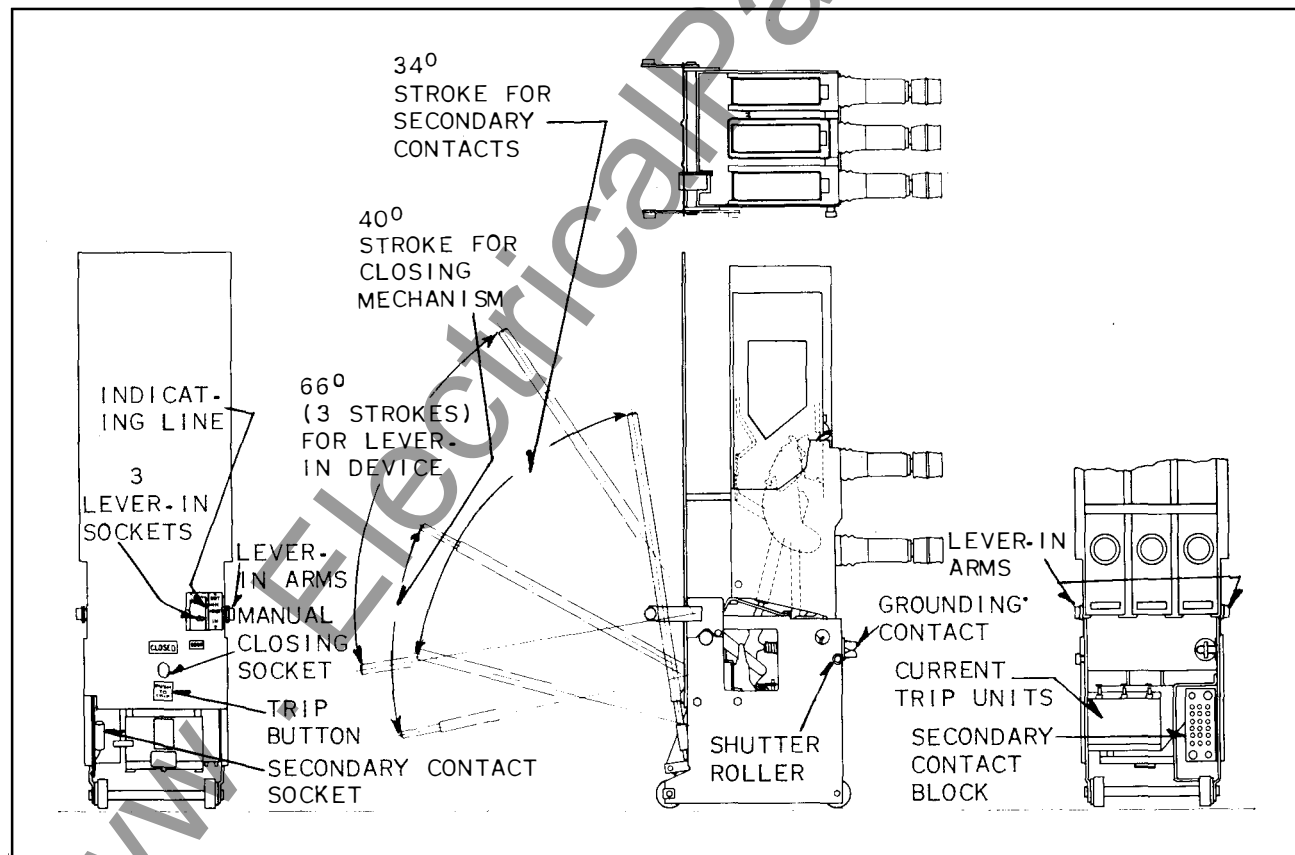

FIG. 6. Breaker Assembly Outline

### ARC CHUTE

The arc chute on the 50-DH-75 air circuit breaker consists of a blowout magnet and coil assembly, two side plates of insulating refractory material, and two arc horns all housed in a rectangular Micarta® jacket illustrated in Figure 7. The arc chute is hinged to the pole unit, and when it is in the normal position, its lower end completely surrounds the contact structure.

The blowout magnet and coil assembly with its arc horns is located in the center of the arc chute. To either side of the blowout magnet and coil assembly are the main ceramic interrupter stacks. These stacks are made of zircon refractory material with an inverted V shape slot molded into them. The slots in the plates are off-set so that when the plates are stacked with the slots alternating from one side to the other, the arc must take a wavy path as it moves up into the arc chute, thus increasing the length of the arc.

Inside the front and rear of the arc chute are the two metallic arc horns to which the arc transfers from the arc contacts. The front arc horn is connected electrically to the moving contact, and the rear arc horn to the stationary contact assembly.

Directly below the blowout magnet and coil assembly is the transfer stack. The purpose of the transfer stack is to interrupt the small part of the arc between the center arc horns, thus inserting the blowout coil in the circuit.

The action of the breaker in interrupting an arc is also shown in Figure 6. When the arcing contacts separate, the arc is drawn between them as indicated by position 1. The arc expands rapidly from this position under the influence of magnetic forces and the thermal effects of the air currents. This causes the arc to pass through the transfer stacks where the short portion between the center arc horns is interrupted putting the blowout coil in series with the arc.

When current starts to flow in the blowout coil, the magnetic field is established and the arc is driven very rapidly up into the slots of the refractory plates. Successive positions of the arc are also shown in the figure. As the arc moves to the closed ends of the slots it is restricted, lengthened, cooled, and subject to a strong magnetically induced blast of gas. All of these actions result in rapid de-ionization of the arc space, and for the arc to maintain itself it must continually ionize fresh gas. At current zero the formation of new ionization momentarily ceases but the de-ionization continues so that

the dielectric strength is established in the arc space and the circuit is interrupted.

### LEVERING-IN DEVICE

To move the breaker in or out of the cell against the resistance of the contact fingers, a levering-in mechanism is provided on the breaker. This consists of a shaft across the front of the breaker that has an interlocking operating casting, and a moving arm at each end. (See Figure 6). Each lever has a roller which engages a slot on the side wall of the cell. The operating handle is inserted in the casting openings provided for the lever and pushed downward in three strokes which in turn moves the engaging levers that draw the breaker into the cell.

Before the breaker is advanced into the cell, the levers on either side of the breaker must be at their extreme rear downward position as shown in Figure 1. When the breaker is levered into the cell operating position, the levers take the position illustrated in Figure 6. With the levers in the rear downward position, the breaker is ready to be advanced into the cell. When the breaker is being advanced into the cell, the rollers on these arms strike a vertical slot in the cell which stops the advancing movement of the breaker.

**This Is The Test Position.** The breaker may be now operated electrically in this position by first engaging the control wiring contact block with the mating block in the cell structure. Figure 6 shows the manual closing handle in the control wiring socket. A 66 degree downward stroke of the handle engages the control circuits. The breaker may now be closed and tripped electrically.

To move the breaker from the "test" position to the "In" or "Operating" position, first the breaker contacts must be in the open position or it will not move. Then insert the small end of the operating handle into the holes of the levering-in casting, and press downward through an arc of approximately 60°. Re-insert the handle in the next advancing hole to appear in the rotation of the casting, and repeat the downward stroke. A total of three strokes engages the breaker to the operating position. The indicating line on the side of the lever-in drive casting shows when the breaker is completely in the cell by lining up with the "in" line on the barrier identifying plate.

To move the breaker from the "in" to the "out" position, repeat the operations in reverse. Three upward strokes of the operating lever are required to free the breaker from the cell.

## OPERATING MECHANISM

**Mechanical Interlock.** The breaker is equipped with a mechanical interlock which engages the levering-in shaft and connects to the closing lever of the mechanism. This prevents the breaker from being levered into or out of the cell with the breaker contacts in the closed position. It also prevents the contacts from closing at any intermediate position between the limits of the "in" and "out" position.

**Secondary Contacts.** The control circuit is arranged for drawout connection by means of an 18 point secondary contact block which plugs into a mating block in the cell. The secondary contact block is mounted on a movable bracket on the lower

left side of the breaker frame. The sliding bracket permits the plug-in connections to be extended to the rear of the breaker so that control circuits may be connected and the breaker operated electrically in the cell test position described above. To engage the secondary control contacts when the breaker is in the test position, insert the small end of the closing handle into the socket on the secondary contact slide and with a downward pressure to release the latch, the handle is pushed downward to the end of its travel. This movement connects the breaker control wiring to the cell control wiring block and the breaker can now be operated electrically in the *test position*.

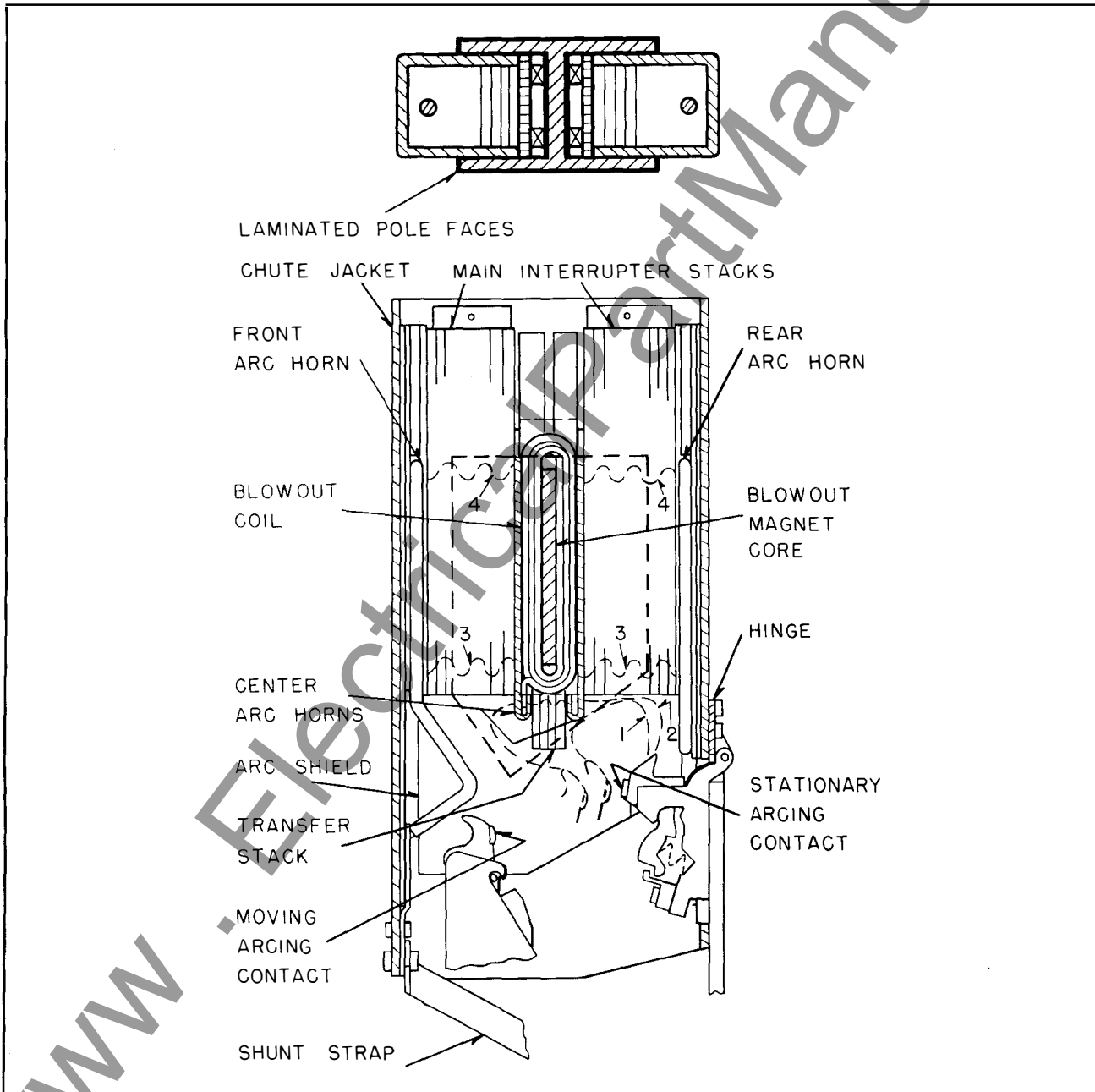

FIG. 7. Arc Chute Arrangement

# MECHANISM ADJUSTMENTS

**Mechanism.** The operating mechanism, illustrated in Figure 4, consists of a series of non-ferrous links and is non-adjustable. Excessive friction can cause the breaker to fail to close by not permitting the links to move freely to the resetting position. The action of the links can be checked by first inserting the manual closing handle, push the tripping button down, and then move the handle through the closing stroke. The linkage system should move, and then retrieve freely without sticking. The latch should then reset to the normal position. If excessive friction is present, several carefully placed drops of liquid molybdenum lubricant No. M-8577-2 can be applied to the links and pins to eliminate this friction.

**Cut-Off Switch.** This switch is operated by a spring-like plate fastened to the bottom of the solenoid moving core. This plate operates to close the switch at the proper time during the closing stroke. The switch contacts must make before the end of the solenoid closing stroke so that the closing coil current will always be cut-off after the closing sequence is completed. This is necessary to prevent any damage to the closed coil. The cut-off must not operate too early in the stroke or the mechanism will

fail to complete the closing cycle. Proper action will be obtained when the switch pushbutton has a  $\frac{1}{32}$  to  $\frac{1}{8}$  inch of overtravel. Ordinarily no adjustment is required. The spring-like action of the pushing plate prevents any damage to the switch on overtravel. Should it be necessary to change the switch operating position, bend the plate slightly to obtain the right switch cut-off action.

**Latch Check Switch.** The latch check switch is mounted on a bracket adjacent to the shunt trip coil. It is mechanically operated by the tripping bar, and the switch operating arm is adjusted by bending the arm slightly so that the contacts are made just as the latch slips over the mechanism trigger. If the switch makes contact too early, the mechanism will fail to latch close. Bend the operating arm to secure the correct switch action.

**Operation Counter.** The operation counter is connected to the mechanism operating lever with a flexible link, and records each breaker operation. The operation counter operating arm can be moved to a position to obtain the required operating stroke action. Any excessive travel is taken up by the flexible connecting link without placing undue force on the operation counter assembly.

## MAINTENANCE

Westinghouse Type DH air circuit breakers are designed to give good life with a minimum of maintenance when the duty is ordinary or moderate. However, the duty will vary greatly with the frequency of operation, and the amount and power factor of the current and faults interrupted, with the many types of application of the breakers. Therefore, the frequency of inspection and the amount of maintenance for any particular application must be chosen with due regard to the kind of duty the breaker is performing. The following remarks are intended as a general guide. Experience on a particular application may show a need for a different maintenance schedule and practice.

Breakers which operate only a few times a year in the light to medium current range of interruption, will require only light routine maintenance. The maintenance should consist of a general in-

spection for mechanical soundness, and a cleaning of any accumulated dust or dirt particularly on primary insulation surfaces, and a few exercising operations. When making these exercising operations, observe the mechanical motions to make certain that they are quickly responsive, snappy, and positive in action with no tendency of any part to stick or hesitate. If there is any stickiness or sluggish motion, operate the breaker slowly by hand to locate the source of friction, and apply a few drops of the lubricant recommended. It is also recommended that breakers which remain closed continuously without any automatic operations, be tried for proper operation at least one every six months.

For breakers which operate a moderate number of times, say 100 to 1,000 operations per year, mechanical stickiness is unlikely to develop and

there will be no need for exercising operations. However, on inspection, more attention should be paid to cleanliness of the interrupter interior, especially if there is a wide range of current interruptions. Large current arcs glaze the ceramic surfaces inside the arc chute, but leave them electrically clean. On the other hand, frequent operation at low or medium currents (about 1,000 amperes or less) tends to cause the accumulation of soot and condensed metal vapor on the parts inside the arc chute, particularly on the ceramic arc shields near the contacts. These deposits may be conducting and may have to be removed as explained under the subject "Arc Chutes".

Breakers which have opened large fault currents near the maximum rating, should be inspected as soon as practical. The condition of the contact surfaces, and the contact adjustments should be checked. Also the interior of the arc chutes should be inspected for cleanliness, degree of erosion, and other irregularities. Minor pit marks on the arc horns are natural, and some wasting of these surfaces is normal and of no concern as long as these parts remain mechanically and electrically stable.

For breakers, which operate frequently such as those on motor starting, and other frequent switching operations, more maintenance will be required, especially when the breaker interrupts large currents as well as the ordinary load currents. Until experience has been acquired on such applications, inspection should be scheduled at least every month. At inspection, such breakers will need close checking of the contact adjustment and the mechanism wear and the adjustment if necessary. Arc chutes will also need cleaning.

### ARC CHUTES

The insulating parts of the arc chutes remain in the circuit across the contacts at all times. During the time that the contacts are open, these insulating parts are subjected to the full voltage across the breaker. The ability to withstand this voltage depends on the care given to this insulation.

On general inspections, blow out the arc chute with the dry compressed air by directing the stream upward from the contact area and out through each of the slots between the ceramic splitter plates, and small splitter plates directly below the blowout coil. Also direct the air stream thoroughly over the arc shields. These are the ceramic liners at the lower end of the arc chute where the arc is first drawn.

The arc chutes should be removed periodically for a thorough inspection. Remove any residue or arc product dirt with a clean dry cloth or by light

rubdown with sandpaper. Do not use a wire brush or emery cloth for this purpose because of the possibility of embedding conducting particles in the ceramic material. If possible, apply 10,000 to 15,000 volts across the arc chute, or the breaker terminals, for one minute to check the condition of the arc chute. The arc chute should withstand this test without any evidence of flashing over.

When inspecting the arc chute look for the following:

**Broken or Cracked Ceramic Parts.** Small pieces broken out of the ceramics, or small cracks in the plates are not important. But large breaks and particularly cracks from the inverted V slots in the interrupter plates out to the edge of the plate or to the top, may interfere with the proper performance of the interrupter. Hence, if more than one or two broken or badly cracked plates are apparent, renewal of the ceramic stack should be made.

**Erosion of Ceramics.** When an arc strikes the ceramic parts in the arc chute, the surface of the ceramic will be melted slightly. When solidified again, the surface will have a glazed white appearance. At low or medium current, this effect is very slight. However, large current arcs repeated many times may boil away appreciable amounts of the ceramic material. When the width of the narrowest point of the slot has been worn to twice its original size (or about  $\frac{1}{8}$  of an inch), the ceramic stack should be replaced.

**Dirt in the Arc Chute.** In service, the arc chute will become dirty from three causes. First, dust deposited from the air can be readily blown out of the arc chute with a dry compressed air stream. Second, loose soot deposited on the inside surfaces of the arc chute in the lower portions near the contacts may be removed by wiping with a clean dry cloth. Third, some deposits from the arc gases will adhere very tightly to the ceramic arc shields near the contacts. These deposits from the metal vapors boiled out of the contacts and arc horns may accumulate to a harmful amount in breakers which get many operations at low or medium interrupted currents.

**Cleaning the Arc Shields.** Cleaning methods for the first two types of dirt are mentioned above. Particular attention should be exercised also to any dirt on the Micarta surfaces exposed to the arc below the ceramic arc shields. Wipe these surfaces clean. If wiping will not remove the dirt, rub with a light grade of sandpaper and refinish carefully with a smooth light coat of red enamel No. 672, or its equivalent. On breakers clearing many operations

at low and medium interrupted currents, tightly adhering dirt may accumulate on the ceramic arc shields sufficiently to impair proper interrupting performance. This tightly adhering dirt can be removed with a coarse sandpaper rub down. Doing this by hand inside the arc chute is slow and tedious. It is more convenient to remove the ceramic shields from the arc chute, and clean them with a power driven sander. Wipe off the sanded surface with a clean dry cloth.

The ceramic arc shields may appear to be dirty and yet have sufficient insulation strength. This can be checked by applying 15,000, 60 cycles for one minute across the arc chute applied between the front and rear arc horns. Also the dirty surface of the ceramic near the contacts should be able to withstand 10,000 volts per inch when test prods are touched directly on the ceramic surface. When the test voltage is applied, there should be no luminous display in the black deposit. If, after wiping and cleaning, or sanding down with sandpaper, the ceramic will not withstand this test, the ceramic shields should be replaced with new ones. When replacing the arc shields wipe off the Micarta surfaces sanding the surfaces down lightly if necessary, and refinish with a thin smooth coat of No. 672 enamel.

After an arc chute has been serviced, apply the voltage test outlined above. When assembling the arc chute on the breaker, be sure to tightly bolt the front arc horn connection to the connection strap from the lower bushing terminal.

### CONTACTS

In normal operation, the arc will make terminal marks all over the arcing contact with some melting blisters. High current arcs will erode contact material more rapidly, but high current arcs move upward very quickly off of the contacts. Low current arcs move slower and their terminals may hop around the arcing contacts for several cycles. Therefore, a breaker which has had many operations at low currents, may be expected to have numerous small blisters and pock marks all over the metal parts supporting the arc contacts. When inspecting the arcing contacts the important condition to be observed is the extent of the erosion of the contact material. When half of the  $\frac{1}{8}$  inch thick arc tip material has gone, the contact should be replaced. This is necessary because the  $\frac{1}{16}$  inch material remaining will be mechanically weakened and might be broken away suddenly during any of the interruptions.

On high fault current operations there may be occasional slight burning on the main contacts. Also

after many operations, main contacts will sometimes become roughened. A fine flat file should be used lightly on the main contact surfaces, removing only enough to take off the high spots. A moderate amount of pitting on the main contact surfaces will not appreciably impair their current carrying ability because of a high contact pressure.

After the contacts have been worn and dressed off as above, contact adjustments should be checked. (See Figure 3.) Some re-adjusting will involve changing position of the rods at the lower end of the insulating operating rod so as to lengthen or shorten the rod. Some mechanics may prefer to do this adjusting on the operating rod with the breaker in the closed position. If this is done the danger in this practice should be understood and safety precautions taken.

*The energy stored in the contact and opening springs can very easily lead to severe personal injury if breaker is accidentally tripped while head or hands are near the moving parts. Therefore a safety block or guard should be put on the breaker to stop the contact arms early in the opening stroke in the event of accidental tripping.*

Ordinarily the only adjustment required will be the compensation for the normal wear of the arcing tips. Each pull rod is fastened to a common cross bar attached to the mechanism through a half inch bolt which can be loosened to either lengthen or shorten the length of the pull rod. When the breaker is closed manually it is important that the stationary contacts have the adjustment clearance as indicated on Figure 3 and the pull rod lengths should be adjusted to obtain these dimensions. The compensation for the adjustment of the arcing contacts can be realized by simply retarding the arcing tip adjustment nut until the contact separation is obtained as illustrated in Figure 3. The bolts and nuts should then be securely locked and re-checked again for proper contact sequence and adjustment.

### ORGANIC INSULATION

Organic insulating materials are used in high voltage air circuit breakers for pole unit supports, operating rods, barriers, braces, arc chutes and similar purposes, where it has been found to be more suitable than porcelain. The material used on Westinghouse breakers is Micarta, which has a long established record for insulating and mechanical dependability. To ensure long continued electrical resistance, the Micarta surface is protected with high grade insulating varnish which may be either

## MAINTENANCE

clear or pigmented, depending on the place of use and the apparatus design requirements.

The purpose of the varnish is to retard moisture absorption and to provide an easily cleaned surface. Like all other insulating surfaces, whether organic or inorganic, a varnished Micarta surface should receive periodic attention in order to maintain the insulation resistance at the highest possible value.

The objects of maintenance are two-fold, first to remove dust and other foreign air borne materials as well as chemical oxides which result from aging of the varnish, and second to make sure that the varnish provides a continuous protective film over the entire insulating surface.

In addition to the usually recommended periodic equipment inspections, on breakers that have been

in service for three to five years, the insulation should be inspected, cleaned, and the varnish renewed if the surface indicates it to be needed.

**Cleaning.** While the surface of the insulation is dry, contamination does not usually cause any large change in insulation value. However, if while it is present, moisture is added in the form of condensation, or by more direct means, the surface electrical leakage may be greatly increased, even to the point of electrical breakdown. The first object of maintenance therefore is cleaning. A clean varnished surface will be smooth, glossy, and free from foreign material either loose or adhering to the surface.

To obtain a clean surface, it is necessary to loosen the adhesive dirt by scrubbing and washing. This is best accomplished in the following manner:

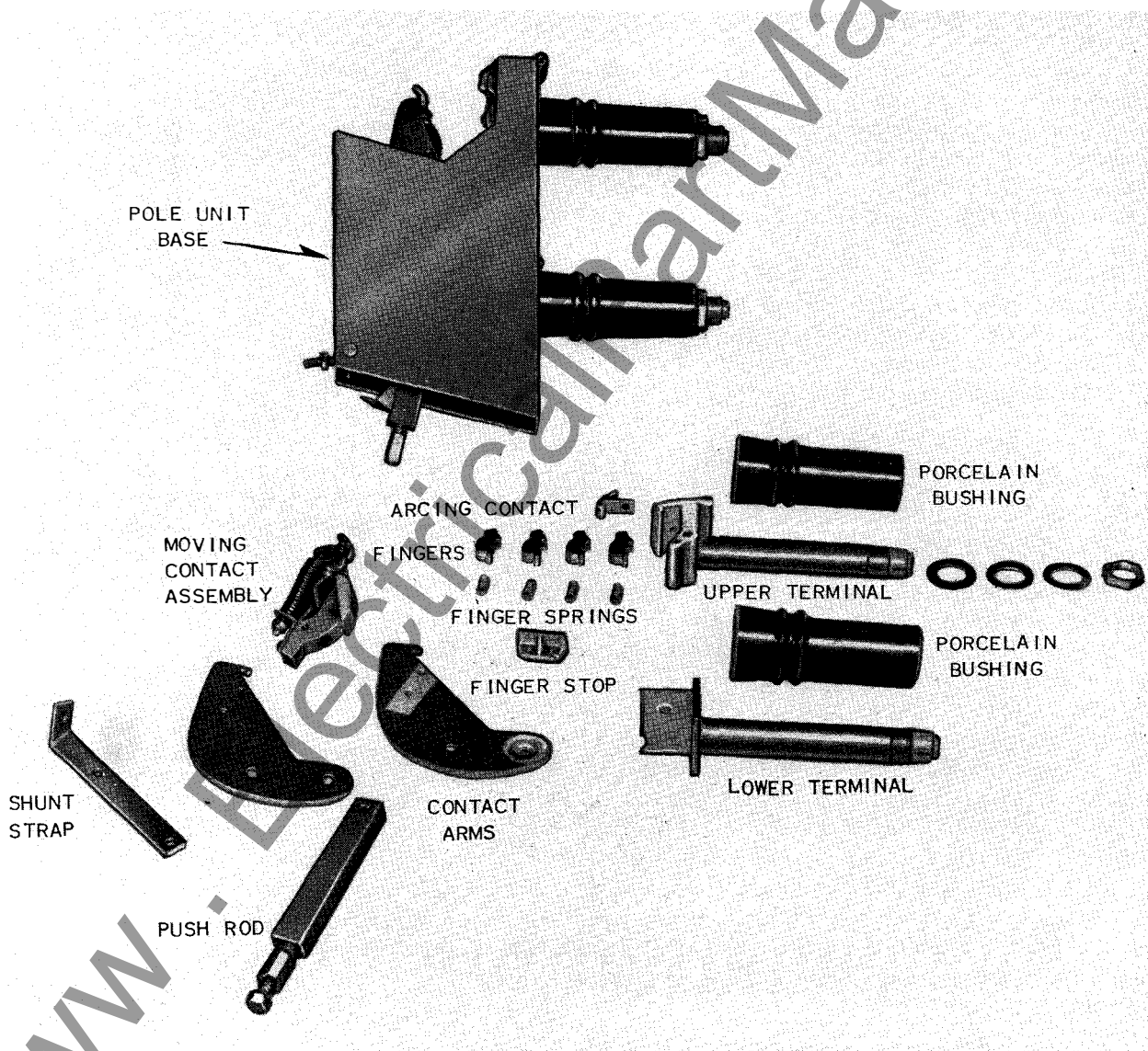

FIG. 8. Pole Unit Assembly

1. Wash with normal heptane, obtainable from the major oil companies such as Esso Standard. Use clean paper towels wet in the heptane. Use a fresh towel on each part.

**Caution:** Heptane is inflammable and no open flames or sparks should be allowed near the work. Provide ample ventilation. Avoid long continued contact to skin by using neoprene gloves.

Normal heptane is recommended for this use because, (a) it will not harm the varnish, (b) it will quickly vaporize, (c) it will leave no residue which might tend to cause wetting action, and (d) it is practically non-toxic assuming good ventilation. If normal heptane is not available, any substitute should meet all above requirements. Acceptable substitutes are straight petroleum distillates such as mixed heptanes, white or non-leaded gasoline without benzol additives, Westinghouse solvent No. 1609-1, or -2, Stoddard solvent, mineral spirits, and cleaners' naphtha.

2. After the heptane has evaporated, which requires only a minute or two, wash with de-ionized water, sometimes called demineralized water, or distilled water.

*Note: De-ionized or demineralized water can be obtained in small quantities from many firms that maintain chemical laboratories, particularly storage battery manufacturers or electroplaters.*

Use fresh paper towels and keep the water in a handy size glass bottle. Wet the towel from the bottle, wash the part and dry immediately with a fresh towel. Use fresh towels for each part.

**Inspection.** When inspecting the insulating parts preparatory to cleaning, wipe off superficial dirt with a dry cloth and note the condition of the varnish and of the Micarta. If the varnish appears in good condition, i.e., fairly smooth and with liberal coverage, proceed with cleaning.

If the varnish appears thin, and is not uniform in coverage, is cracked, or can be peeled off with the fingernail, the parts should be revarnished.

**Varnishing.** Varnishing can be done with the parts in position on the breaker, as follows:

1. Sandpaper when needed to remove loose varnish and wipe off all dust from sanding.

2. Apply three coats of varnish, Westinghouse M#135-2. Allow 24 hours drying time between coats at ordinary temperatures. Drying time may be decreased by preheating parts with infra-red lamps to a temperature of 40 to 50 degrees C before applying varnish and likewise heating each coat for about 4 to 8 hours, or until the varnish has set up to the point where it will not be lifted by applying the succeeding coat.

**Laminated Insulation.** Resin bonded laminated insulating materials are formed under pressure at high temperature. The release of pressure, reduction of temperature and some further shrinking of the resin bond produces internal stresses. Relieving of these stresses may result in the formation of minute cracks or checks along the laminated edges of the insulation. Such cracks, if small, are sealed by the varnish and are not harmful.

**PARTS IDENTIFICATION AND RENEWAL**

Detailed parts identification for the pole unit assemblies is shown in the illustration of Figure 8.

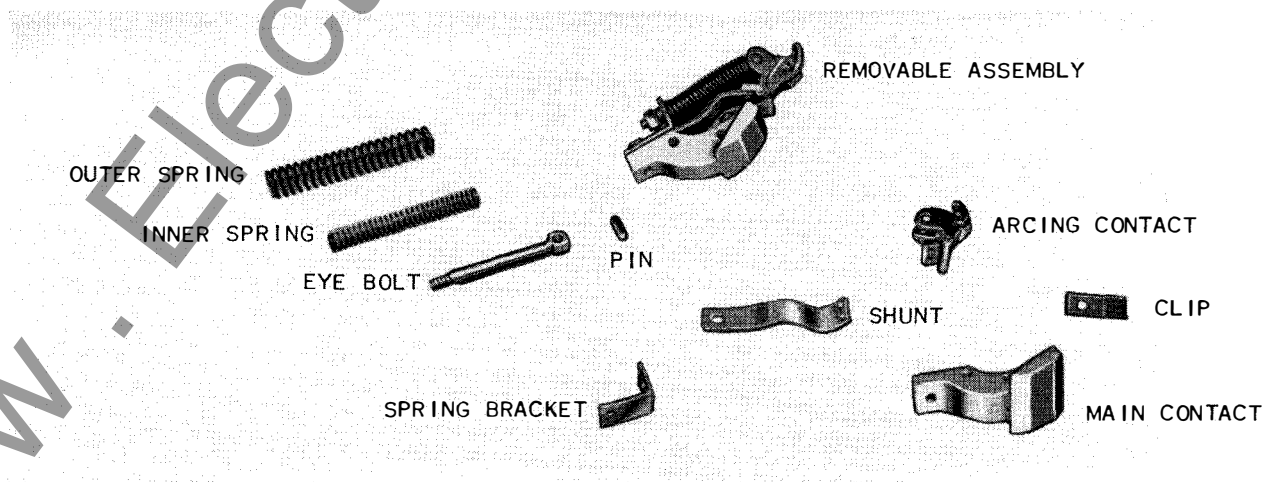

**FIG. 9. Moving Contact Assembly**

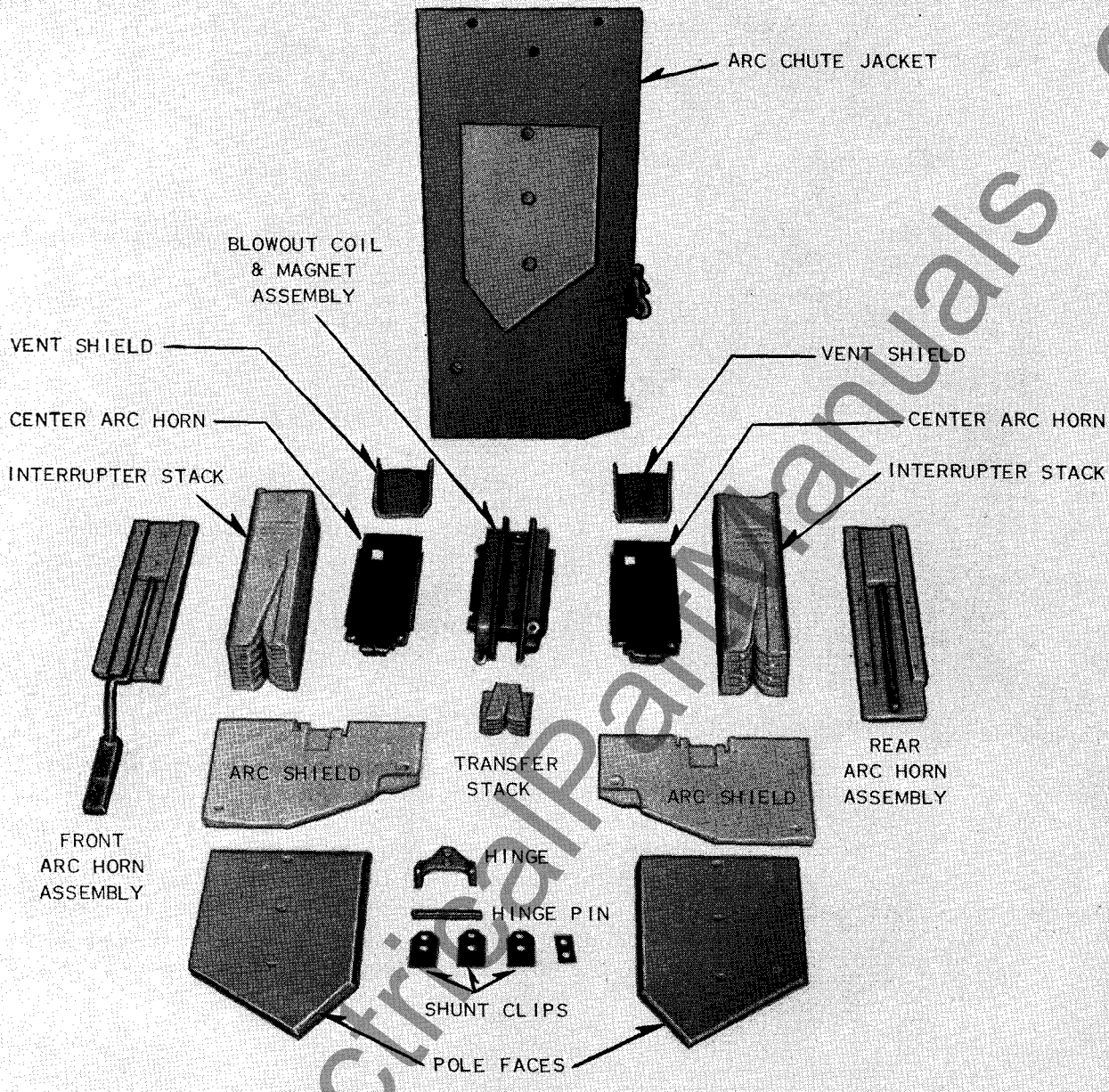

FIG. 10. Arc Chute Assembly

Detailed parts identification for the moving contact assembly are shown in Figure 9. Detailed parts identification for the arc chute assembly are shown in Figure 10.

**Pole Unit.** The change of parts for the pole unit, and moving contacts is relatively easy, requiring only that the parts that are fastened together be bolted securely, and that parts requiring free movement be checked to see that the parts move freely as required. Alignment and adjustment of the con-

tacts should always be checked for proper operation after replacements are made.

**Arc Chute.** Servicing the arc chute would most generally involve some of the items shown in Figure 10. The interrupter stacks, of which there are two, can be removed and replaced by simply removing the retaining fibre pieces at the top of the arc chute, and then pushing each ceramic section towards the top of the jacket. The new ones can then be slipped back in place. The two side arc

shields can be removed by unfastening the side assembly screws. The arc shields should then slip out easily. After a new arc shield has been placed, the screws should be tightened *just to take up the loose motion* and then cut the excess length of threads with a pair of side cutters. This will flare the threads and prevent the bolt from loosening (*this step is important*).

The small transfer stack is available as a cemented unit, and should be replaced with a completely new assembly. This can be done by first removing the arc shields, which will permit the assembly to drop out.

The front and rear arc horns will seldom require replacing as long as they remain mechanically intact. Small blisters or arc marks on the surfaces of the metal horns are unimportant. The supporting asbestos composition plates should be replaced if they are broken, or if the surfaces are worn enough to break through to endanger the micarta jacket inside surfaces.

The blowout magnet assembly will rarely be changed, except for the replacement of the center arc horns. The center arc horns will exhibit some blistering and wearing of the curved bottom ends. As long as the curved ends remain mechanically intact, there will be no need for replacement.

When servicing of the blowout magnet becomes necessary, a certain procedure must be followed so that the whole assembly can be removed from the jacket. First, the entire stack will have to be dismantled. The jacket sides will then have to be expanded enough to allow the whole magnet assembly to be drawn out from the top. The reason for this is that the center arc horns have a  $\frac{3}{16}$  projecting end at each side that trap the whole assembly into the arc chute jacket opening. Several wooden wedges should be driven at each side of the magnet until the assembly can be pulled out. The wedges should be held in place until the serviced assembly is re-assembled in place.

Precautions should be taken to see that the bolted connections of the blowout coils are tightly secured

before returning the assembly into the arc chute jacket.

Other parts such as the closing coil, trip coil, and control devices can be identified for the particular breaker by reporting the breaker nameplate data, or referring to renewal parts data sheets.

**Renewal Parts.** A list of renewal parts recommended to be kept in stock will be furnished upon request. When ordering renewal parts, specify the name of the part, and include all of the information given on the breaker nameplate.

<b>WESTINGHOUSE</b>			
<b>METAL GLAD SWITCHGEAR</b>			
<b>DE-ION AIR CIRCUIT BREAKER</b>			
<b>DH</b>			
<b>STYLE OR SO</b>		<b>DATE OF MANUFACTURE</b>	
<b>SERIAL</b>		<b>BREAKER UNIT &amp; CODE</b>	
<b>RATED KV</b>		<b>WILL FIT HOUSING CODE</b>	
<b>MAX DESIGN KV</b>		<b>TYPE MECHANISM</b>	
<b>AMPERES</b>		<b>CLOSING VOLTAGE</b>	
<b>CYCLES</b>		<b>TRIPPING VOLTAGE</b>	
<b>PATENTS</b>		2442199	2276968
		2243038	2243040
		2242905	2177014
<b>WESTINGHOUSE ELECTRIC CORP.</b>			
<b>NP54068-C</b>		<b>MADE IN U.S.A.</b>	

www.electricalart.com

**MEMORANDUM**

[www.ElectricalPartManuals.com](http://www.ElectricalPartManuals.com)