

CONTACT ADJ.

PAGE 9

LUBRICATION

PAGE 6

Instructions for Types DB-50 and DBF-16 Air Circuit Breakers



Westinghouse Electric Corporation

Assembled Switchgear & Devices Division, East Pittsburgh, Pa.

I.B. 33-850-3A, Effective November, 1962. Supersedes I.B. 33-850-3, July, 1959

Table of Contents

	Page
Part 1 - Receiving, Handling, and Storing	
Inspection	6
Storing	6
Part 2 - Installation	
Connections	7
Part 3 - Maintenance	
Pole Unit	9
Contacts	9
Maintenance of Contacts	9
Operating Mechanism	9
(Closing Spring Mechanism) Spring Closing Assembly	9
Closing Solenoid	9
Overcurrent Tripping Device	12
Installation and Removal	13
Overtravel Adjustment	13
Construction	14
Time-Current Classification	15
Operation	15
Time-Current Characteristics	20
Adjustment of Calibration Settings	20
Control Relay	23
Shunt Trip Attachment	25
Undervoltage Trip Attachment	26
Undervoltage Time Delay Attachment	26
Reverse Current Trip Attachment	26
Field Discharge Switch	27
Auxiliary Switch	29
Alarm Switch Attachment	29
Electric Lockout Attachment	29
Key Lock Attachment	31
Key Interlock Attachment	31
Rectifier Unit for A-c Undervoltage and A-c Electric Lockout Attachments	31

www.ElectricalPartManuals.com

List of Illustrations

Figure		Page
1	DB-50 Outline Dimensions and Mounting Details	8
2	Typical Wiring Diagrams - Type DB-50 Circuit Breaker	10
3	Cross-Sectional View of Type DB-50 Circuit Breaker.	11
3A	Type DB-50 Spring Closing Assembly	12
4	Series Overcurrent Tripping Device with Long Delay and Instantaneous Elements	13
5	Series Overcurrent Tripping Device Showing the Assembly of Calibration Case to Magnetic Circuit.	13
6	Cross-Sectional View of Series Overcurrent Tripping Device with Long Delay and Instantaneous Elements	14
7	Tripping Characteristics of Standard Series Overcurrent Tripping Device with Long Delay and Instantaneous Elements	16
8	Tripping Characteristics of Selective Series Overcurrent Tripping Device with Long Delay and Short Delay Elements	17
9	Tripping Characteristics of Special Series Overcurrent Tripping Device with Instantaneous Element Only	18
10	Schematic Diagram of Standard Series Overcurrent Tripping Device with Adjustable Long Delay and Adjustable Instantaneous Elements	19
11	Schematic Diagram of Selective Series Overcurrent Tripping Device with Adjustable Long Delay and Adjustable Short Delay Elements	21
12	Schematic Diagram of Series Overcurrent Tripping Device with Instantaneous Element Only	21
13	Discriminator for Tripping Device	22
14	Closing Solenoid - Construction Details	23
15	Control Relay - Adjustment and Construction Details	24
16	Shunt Trip Attachment - Construction Details	25
17	Undervoltage Trip Attachment - Construction Details.	27
18	Undervoltage Time Delay Attachment - Construction Details	28
19	Reverse Current Trip Attachment - Construction Details.	28
20	Field Discharge Switch - Construction Details	30
21	Auxiliary Switch - Construction Details	30
22	Alarm Switch Attachment - Construction Details	31
23	Electric Lockout Attachment - Construction Details	32
24	Key Lock or Key Interlock Attachment - Construction Details	33
25	Rectifier Unit for A-c Undervoltage and A-c Electric Lockout Attachments	34

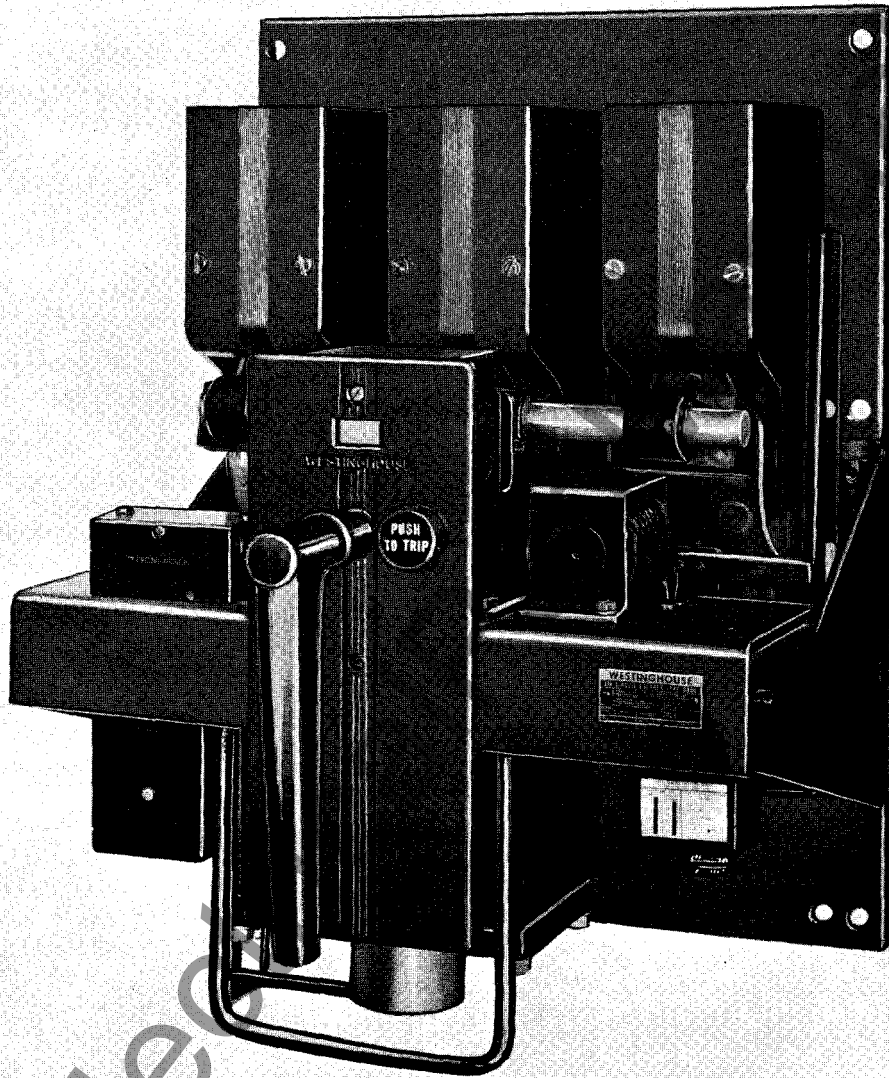

www.Electricals.com

General

Type "DB" air circuit breaker is designed to give continuous and reliable service as the protective link between the power source and associated productive equipment. This breaker is built to operate with a minimum of maintenance, while at the same time its simplified construction permits maximum accessibility for inspection and adjustment when required. The ease with which attachments may be added or removed is an outstanding feature of the "DB" design.

For the greatest measure of safety to operating personnel and also to minimize maintenance requirements, the breaker should be mounted in an enclosure suitable to local operating conditions. A selection of standard enclosures is available for various applications.

IMPORTANT: To assure proper functioning, inspect each breaker at regular intervals in accordance with a systematic maintenance schedule. The frequency and character of the inspections will for the most part be determined by the severity of the duty performed. The minimum requirements, however, should consist of a light monthly inspection, with a thorough inspection semi-annually. Occasional checks on calibration as well as on coordination and freedom of all moving parts, must be included in the maintenance schedule. Consult Westinghouse engineering and service personnel for recommendations pertaining to special operating or maintenance conditions.

PART 1 - RECEIVING, HANDLING, AND STORING

Type "DB-50" air circuit breakers, with all attachments mounted in place, are shipped in special cartons.

Important: To avoid damage to the breakers, do not use hooks in handling.

Net weights of Type DB-50 are given in Table No. 1 below.

TABLE NO. 1

Type DB-50

	2-Pole	3-Pole
MANUAL	220 lbs.	280 lbs.
ELECTRIC	295 lbs.	355 lbs.

Add 30 Lbs. for Drawout Details.

Immediately upon receipt, examine shipment for any loss or damage incurred during transit. If injury or rough handling is evident, file a damage claim at once with the transportation company and notify the nearest Westinghouse Sales Office.

When unpacking, be sure that no loose parts are missing or left in the packing material. Report all shortages at once. Blow out any dust or particles of packing material that may have accumulated on the circuit breaker parts. Do not remove tape from top of arc chutes until breaker is to be placed in service.

INSPECTION

The "DB" breaker assembly consists of a coordinated group of sub-assemblies mounted on a steel supporting panel. The complete breaker assembly is to be mounted with the steel panel in a vertical position. All inspections for proper operation should, therefore, be made with the breaker in this position. Final inspection should preferably be made with the breaker in its permanent mounting.

Inspect the breaker as follows:

1. Raise and lower the trip bar by hand to make sure that it does not bind.

2. Rotate the manual operating handle slowly in a clockwise direction to move the contacts toward the closed position.

- a. Observe whether all parts are in proper alignment and move freely.

- b. Make certain that the studs have not been forced out of alignment.

- c. Be sure that the contacts are clean and properly aligned. For a description of contact alignment, refer to "Contacts", Page 9.

3. If the contacts are in alignment and all parts move freely, continue the clockwise rotation until the breaker is latched.

4. Push the push-to-trip button to trip the breaker.

- a. The toggle linkage should collapse and the moving contact assembly move freely to the full open position. This should be followed immediately by complete re-setting of the links in the toggle mechanism.

- b. The links must always be free to move without friction or binding.

5. Check the attachments for operation in accordance with the appropriate instructions as given under "Maintenance", Part 3 of this book.

NOTE: It is not advisable to lubricate any parts of the breaker. The lubrication supplied during factory assembly is sufficient for years of service. The lubricant is of a special form which is used sparingly. The addition of oil will only promote the accumulation of dust and dirt.

STORING

If circuit breakers are not to be installed in their permanent location at once, they should be carefully inspected for loose or damaged parts and then stored in a clean dry place in an upright position to avoid damage to the circuit breaker parts. A covering of paper will prevent dust from settling on the circuit breaker parts and is preferred to packing or other materials that are apt to absorb moisture.

PART 2 - INSTALLATION

Type "DB-50" circuit breakers are furnished as complete unit assemblies and the installation consists of: (1) bolting them to the supporting framework or structure; (2) connecting the current-carrying cables or bus bars; and (3) completing any secondary control wiring that may be necessary.

CAUTION: During installation, the circuit breaker should be in the open position. Be sure to de-energize the load and control leads to be connected, and also the section of the switchboard where installation is being made.

Mounting dimensions and details of the front enclosure cutouts are shown in Fig. 1.

To prevent distortion of the breaker panel, the supporting structure should be checked for alignment.

CONNECTIONS

Typical circuit breaker wiring diagrams are shown in Fig. 2. The connecting cables or bus bars should have adequate current-carrying capacity, otherwise, heat will be conducted to the circuit breaker resulting in possible excessive temperature rise. Connecting cables or bus bars must be supported so that the circuit breaker studs will not be subjected to unnecessary stresses.

The circuit breaker studs and all connections should be clean, smooth, and free from burrs to assure full contact area. They should be firmly clamped or bolted in place to prevent excessive heating.

TABLE NO. 2

Closing Solenoid Control Voltages, Tripping Currents, Closing Currents and Fuse Ratings

CLOSING COIL BURDEN	NOMINAL CONTROL VOLTAGE	CLOSING AMPERES	TRIPPING AMPERES	RECOMMENDED CLOSING FUSE AMPERE RATING STANDARD NEC		FUSE STYLE NUMBER
				250 VOLT	600 VOLT	
* STD.	24 DC	---	9.5			
	48 DC	---	4.9			
	125 DC	18	2.2	10		120A823H04
	250 DC	8	1.1	6		120A823H03
	230 AC	18	3.7	10		120A823H05
	460 AC	8	1.4		6	120A824H03
	575 AC	4	1.0		3	120A824H01
	115 AC	---	7.3			
△ HIGH	24 DC	---	9.5			
	48 DC	---	4.9			
	125 DC	128	2.2	40		120A823H10
	250 DC	62	1.1	25		120A823H07
	230 AC	80	3.7	25		120A823H07
	460 AC	39	1.4		15	120A824H05
	575 AC	25	1.0		10	120A824H04
	115 AC	---	7.3			

* For A-C closing use 3 KVA source or larger. Supplied for breakers having dual overcurrent tripping devices (Long Delay - Instantaneous Type) or for breakers having dual selective overcurrent tripping devices (Long Delay - Short Delay Type) plus discriminator details.

△ May be supplied for match up breakers having dual selective overcurrent tripping devices (Long Delay - Short Delay Type) without discriminator details.

PART 3 - MAINTENANCE

POLE UNIT

Each pole unit is mounted on a separate molded base through which the breaker studs pass. (See Fig. 3.) The molded bases are attached to the steel mounting panel and provide insulation for the breaker studs.

The upper stud and contact are attached to the molded base by two bolts. The moving contact is pivoted on the molded base and attached to the cross bar through insulating links. The series coil and lower stud are fastened to the molded base by four bolts.

Contacts. (See Fig. 3.)

The DB-50 arcing contact should touch first on closing, open last on opening. Contact pressure on the mains is maintained by adjusting gap G to be .078-.093 inches. This gap is adjusted by removing the cross bar and screwing the insulating link in or out on the stud. Be sure to tighten the lock nuts after each adjustment.

Do not over-adjust as this will cause the contact springs to compress to the solid position and thus increase the closing effort. Check for over-adjustment by prying the stationary arc tips open to at least 1/16-inch gap.

Maintenance of Contacts.

Rough or high spots should be removed with a file or sandpaper. To replace the arcing contacts, open the breaker, remove the arc chutes and then the stationary arcing contacts. Close the breaker and remove the moving arcing contacts. The new contacts can then be added in the reverse order.

CAUTION: All power should be removed when changing, maintaining or adjusting contacts.

OPERATING MECHANISM

The operating mechanism (see Fig. 3) is non-adjustable and consists of a series of

non-ferrous links designed to secure low closing and tripping forces. To check for friction, raise the trip bar and slowly rotate the manual operating handle in close direction. The linkage should follow the handle without sticking.

A small quantity of lubricant is placed on the handle shaft, the roller lever roller, and the latch plate at the factory.

CLOSING SPRING ASSEMBLY

The closing spring assembly is shown in Fig. 3A.

Rotating the closing handle clockwise raises the lift link and lower spring guide to compress the closing spring. Near the end of the closing stroke the top end of the lift link strikes the first toggle lever to start the breaker closing. As the breaker closes, the push rod raises the toggle link and push link out of the toggle which permits the closing spring to complete the breaker closing.

Slow emergency operation to check the contact sequence can be obtained by exerting a slight closing pressure on the closing handle and simultaneously pushing forward on the breaker cross bar to start the breaker closing.

Maintenance

Oil the pins and slides every 10,000 operations.

CLOSING SOLENOID

The closing solenoid (see Fig. 14) is non-adjustable. It is designed for intermittent duty only. Check for loose bolts.

To remove closing coil, trip breaker. Disconnect closing coil leads from control circuit wiring. Take off bolts (9), washers (12), relay release arm (8), bolts (10), washers (11) and plate (2). Drop closing coil (7) with brass tube (5).

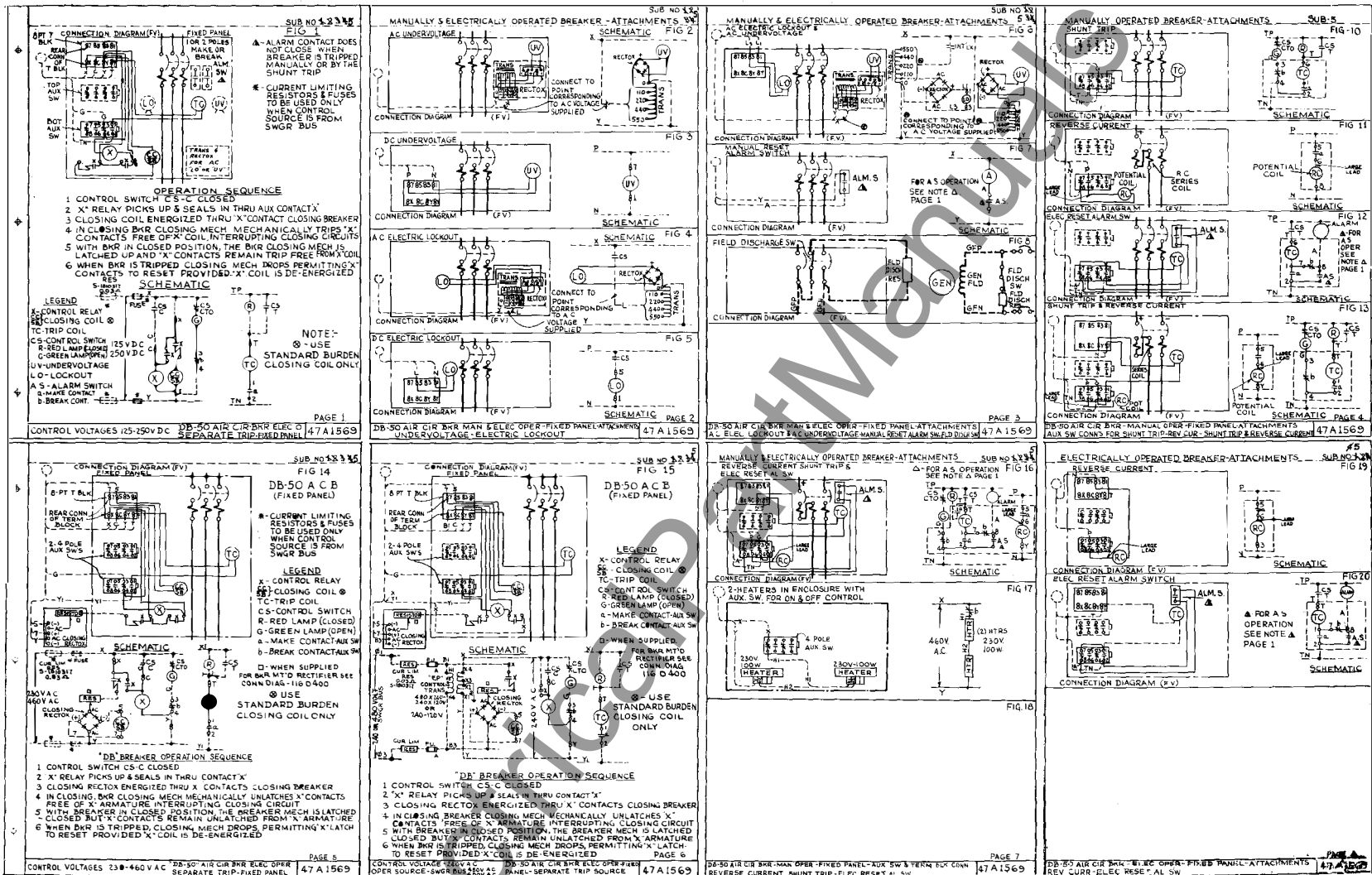
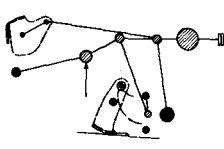
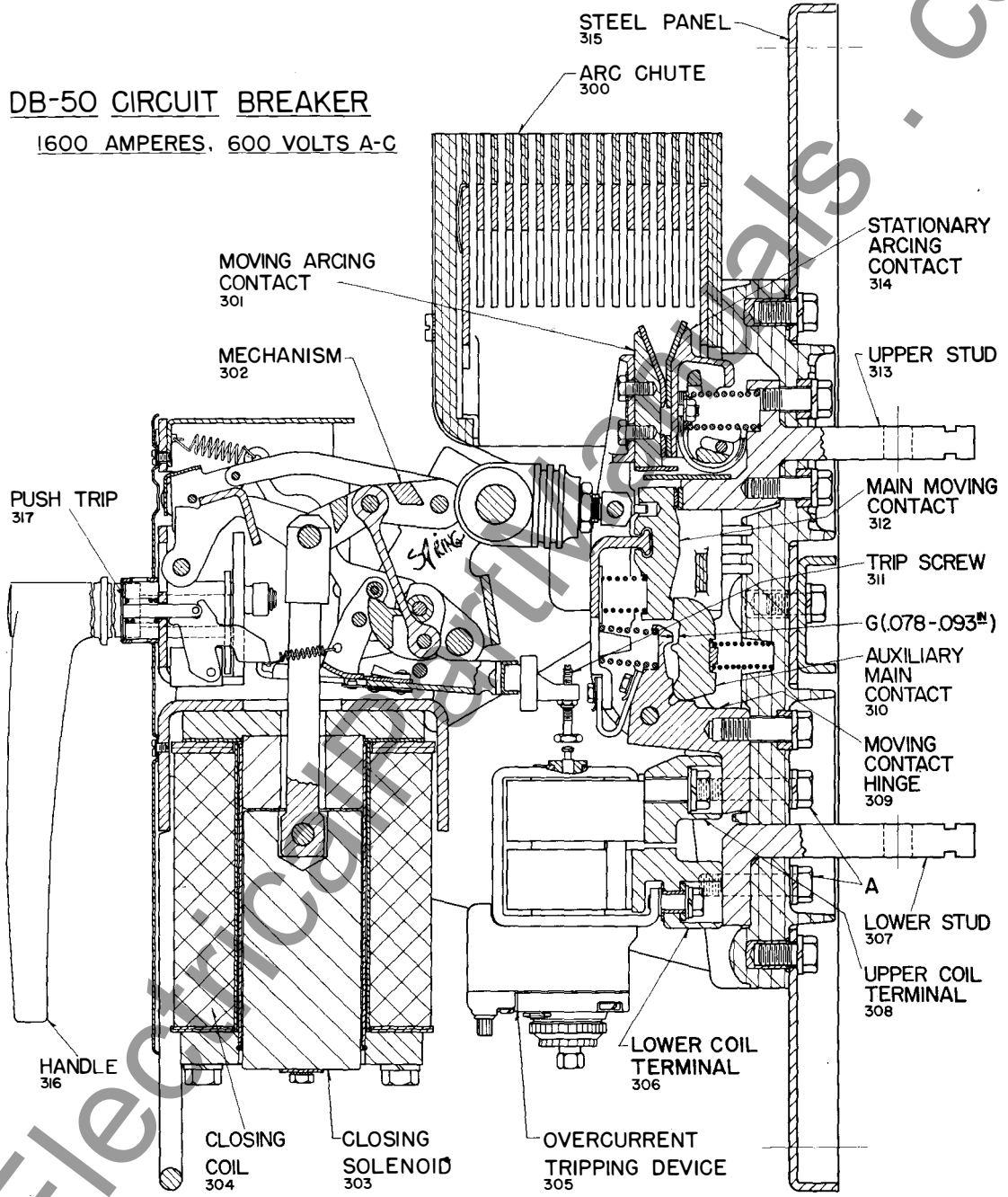

Fig. 2 - Typical Wiring Diagrams - Type DB-50 Circuit Breaker

DB-50 CIRCUIT BREAKER

1600 AMPERES, 600 VOLTS A-C



CLOSED

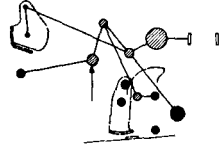

TRIPPED

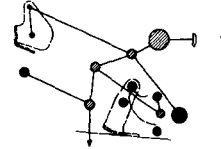

OPEN (RESET)

Fig. 3 - Cross-Sectional View of Type DB-50 Circuit Breaker

In replacing closing coil be sure to re-
place brass tube (5) so that stationary core
(4) and moving core (3) are aligned in the
tube. Re-assemble closing coil and details
in reverse order from removal.

If the circuit breaker is permanently
mounted near the floor so that the closing
coil cannot be dropped far enough for re-
moval then follow these directions. Trip
breaker and remove breaker manual oper-
ating handle and breaker face plate. Dis-
connect closing coil leads from control cir-
cuit wiring. Take off bolts (9), washers
(12), relay release arm (8), bolts (10),
washers (11) and plate (2). Drop closing
coil (7) with brass tube (5) so that pin (6)
is exposed. Push pin (6) to right into hole
on right hand side of solenoid yoke (1) and
allow moving core (3) to drop into brass

tube (5). Pick up closing coil with brass
tube and moving core and bring out through
the U-shaped foot on breaker.

Re-assemble closing coil and details
in reverse order from removal. Take care
to align stationary core (4) and moving core
(3) in brass tube (5).

The minimum permissible control volt-
ages at the terminal of the closing coil, and
the closing currents at normal voltage are
listed in Table No. 2 shown on Page 7.

OVERCURRENT TRIPPING DEVICE

The overcurrent trip is an air delayed
device that can be supplied with various
rating coils ranging from 200 to 1600 am-

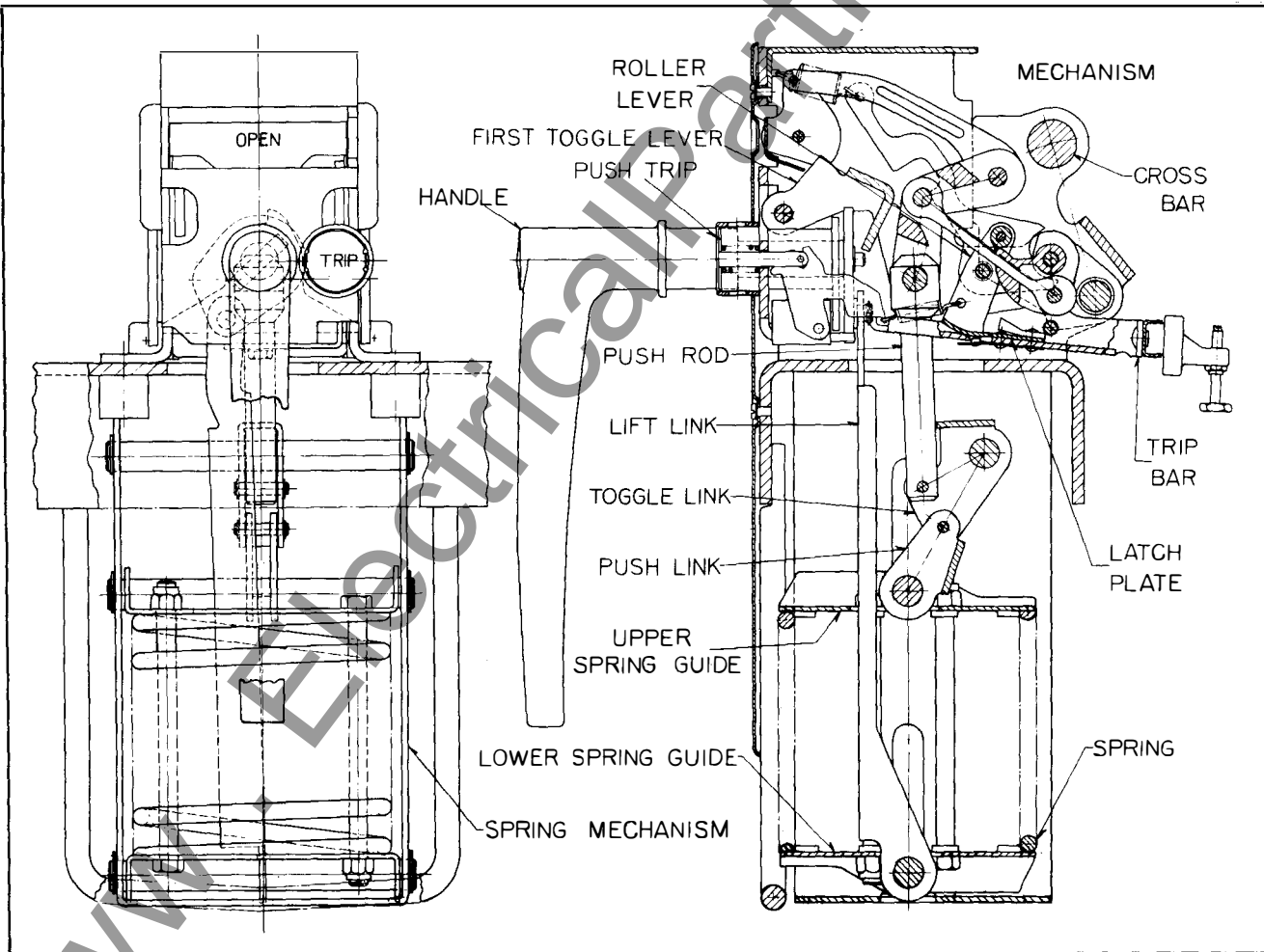

Fig. 3A - Type DB-50 Spring Closing Assembly

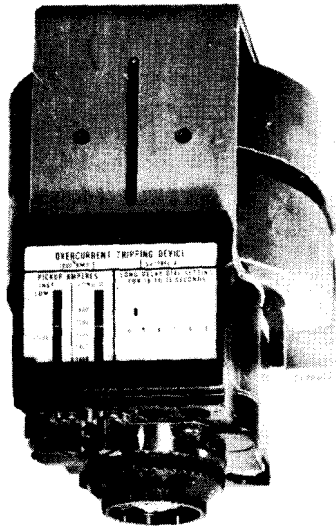

Fig. 4 - Series Overcurrent Tripping Device with Long Time and Instantaneous Element

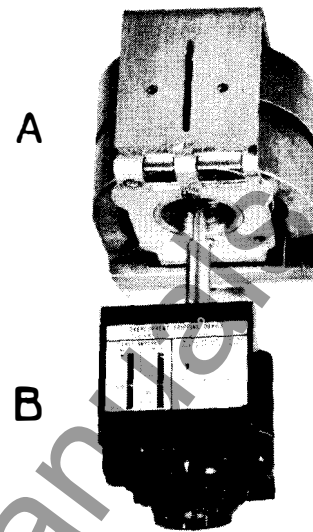

Fig. 5 - Series Overcurrent Tripping Device Showing the Assembly of Calibration Case to Magnetic Circuit.

peres. The construction, except for the coils, is similar for all ratings.

The overcurrent tripping device can easily be removed from the breaker and replaced with another unit of different rating or of the same rating without affecting the calibrations.

Installation and Removal

CAUTION: Before removing or installing a tripping device, be sure that the breaker is in the open position and de-energized. To remove an overcurrent tripping device from the breaker, remove the four bolts A Figure 3 which hold the tripping device to the breaker base. Before removing the last bolt, hold the tripping device to prevent it from falling.

To install the overcurrent trip to the circuit breaker it is merely necessary to insert the device into the pole unit so that the upper coil terminal makes contact with the lower part of the moving contact hinge and the lower coil terminal contacts the lower breaker stud as shown in Fig. 3. The unit is then bolted in this position by means of four hexagon head, steel bolts 2-1/2 inches long shown at A, Fig. 3. Use only one lock washer under the head of each of the bolts. Care should be taken to make sure that bolts

longer than specified above are not used, because the ends of the bolts may bottom in coil terminal thereby causing a loose connection.

OVERTRAVEL ADJUSTMENT

CAUTION: Do not attempt to check overtravel adjustment until the breaker has been completely disconnected from any normal voltage source.

The trip screw mounted on the trip finger above the overcurrent tripping device should be adjusted to get the same amount of overtravel that occurred when the tripping device was calibrated for time delay. If a tripping device is removed for any reason, and reinstalled on the breaker, the overtravel adjustment should be rechecked. When a new tripping device is installed the overtravel must be adjusted.

To manually check the overtravel refer to Fig. 6. The air delay device can be made inoperative by opening the instantaneous valve (or the short delay valve in the case of selective type tripping devices). The valve is opened by lifting the instantaneous (or short delay) armature. A slot is provided in the side of the molded case and a small rod approximately 1/16 diameter can be entered through the side of the case and used as a lever to lift the armature. After the valve is blocked open, the trip plunger

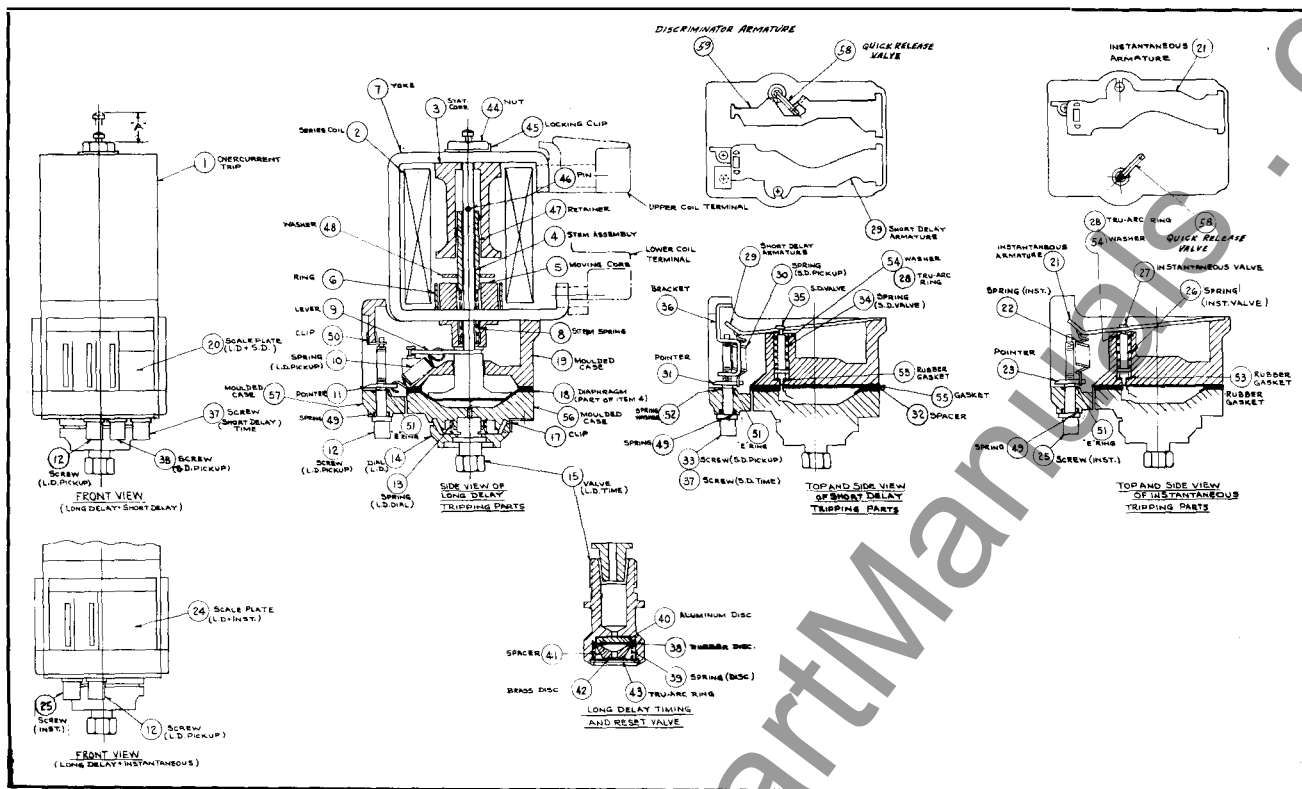

Fig. 6 - Cross-Sectional View of Series Overcurrent Tripping Device with Long Delay and Instantaneous Elements

can readily be moved upward to check the tripping action. The trip plunger extends out the top of the tripping device and has a neck and head under which a forked tool can be engaged to lift the trip plunger against the trip screw. Close the breaker and move the trip plunger upward being careful to keep hands and face clear of parts which move when the breaker trips. Adjust the trip screw until the trip plunger moves it just far enough to trip the breaker. Repeated trials may be necessary. Trip and close the breaker before each trial so that normal latch lap will always be used. When adjustment, which gives just enough travel of the trip bar to trip the breaker, has been found, add the standard overtravel which is one-half turn of the trip screw downward.

Construction

The overcurrent tripping device is air delayed with all of its elements completely adjustable. A typical unit is shown ready for mounting on a circuit breaker pole unit in Figure 4.

The tripping device consists of two main subassemblies namely:

1. The magnetic frame and coil assembly as shown in Figure 5A.
2. The delay elements assembly as shown in Figure 5B. The two assemblies are held together by means of the two white mounting screws as seen from the bottom of the calibration case.

As seen from the sectional view Figure 6, the magnet frame and coil assembly consists of a yoke, a coil, a stationary and moving core together with their necessary insulation.

The delay elements assembly as seen from the same figure contains an air chamber, a diaphragm, and trip plunger as well as all the armatures, springs, and valves to produce the adjustable long delay, short delay and instantaneous characteristics of the circuit breaker tripping curve.

Time-Current Classification

The overcurrent tripping devices can be supplied with any combination of the three tripping elements, namely, long delay, short delay, and instantaneous elements. The most popular combinations are listed below:

1. Dual Overcurrent Series Tripping Device

This unit has an adjustable long delay and an adjustable instantaneous element, the characteristic curve of which is shown in Figure 7.

The calibration for the various elements are:

(a) Long delay pick-up

Adjustable with calibrated marks at 80-100-120-140 and 160 percent of coil rating.

(b) Long delay

Adjustable with two calibrated marks at 30 and 20 seconds. Calibrated marks at 20 and 12 seconds or at 60 and 40 seconds may be supplied for special applications.

(c) Instantaneous pick-up

Adjustable with two calibrated marks at 800-1200 percent or 500-1000 percent.

2. Dual Selective Overcurrent Series Tripping Device For Group or Tie Breakers

A selective device is equipped with an adjustable long delay and an adjustable short delay element. These two elements combine to give a typical selective curve as shown in Figure 8. This unit can be made selective with a standard device or another selective device of the same or of a different rating.

The calibration for the various elements are:

(a) Long delay pick-up

Adjustable with calibrated marks at 80-100-120-140 and 160 percent of coil rating.

(b) Long delay

Adjustable with two calibrated marks at 30 and 20 seconds. Calibrated marks at 20 and 12 seconds or at 60 and 40 seconds may be supplied for special applications.

(c) Short delay pick-up

Adjustable with calibrated marks at 500-750 and 1000 percent of coil rating.

(d) Short delay

Adjustable with calibrated marks at 6-14 and 30 cycles.

3. Instantaneous Trip Only

This device is equipped with an adjustable instantaneous element only. A typical time-current characteristic for such a device is shown in Figure 9.

This device is available with an instantaneous pick-up which is adjustable and has calibrated marks at 80-100-120-140 and 160 percent of coil rating.

OPERATION

1. Dual Overcurrent Series Tripping Device

An overload or short circuit through the series coil D, Fig. 10, will cause the moving core C to be attracted and move toward the stationary core B. At low currents, the moving core C will carry the tripping stem F along with it, and the motion will be retarded by the diaphragm E. The rate of travel of the diaphragm is determined by the rate at which air is permitted to enter

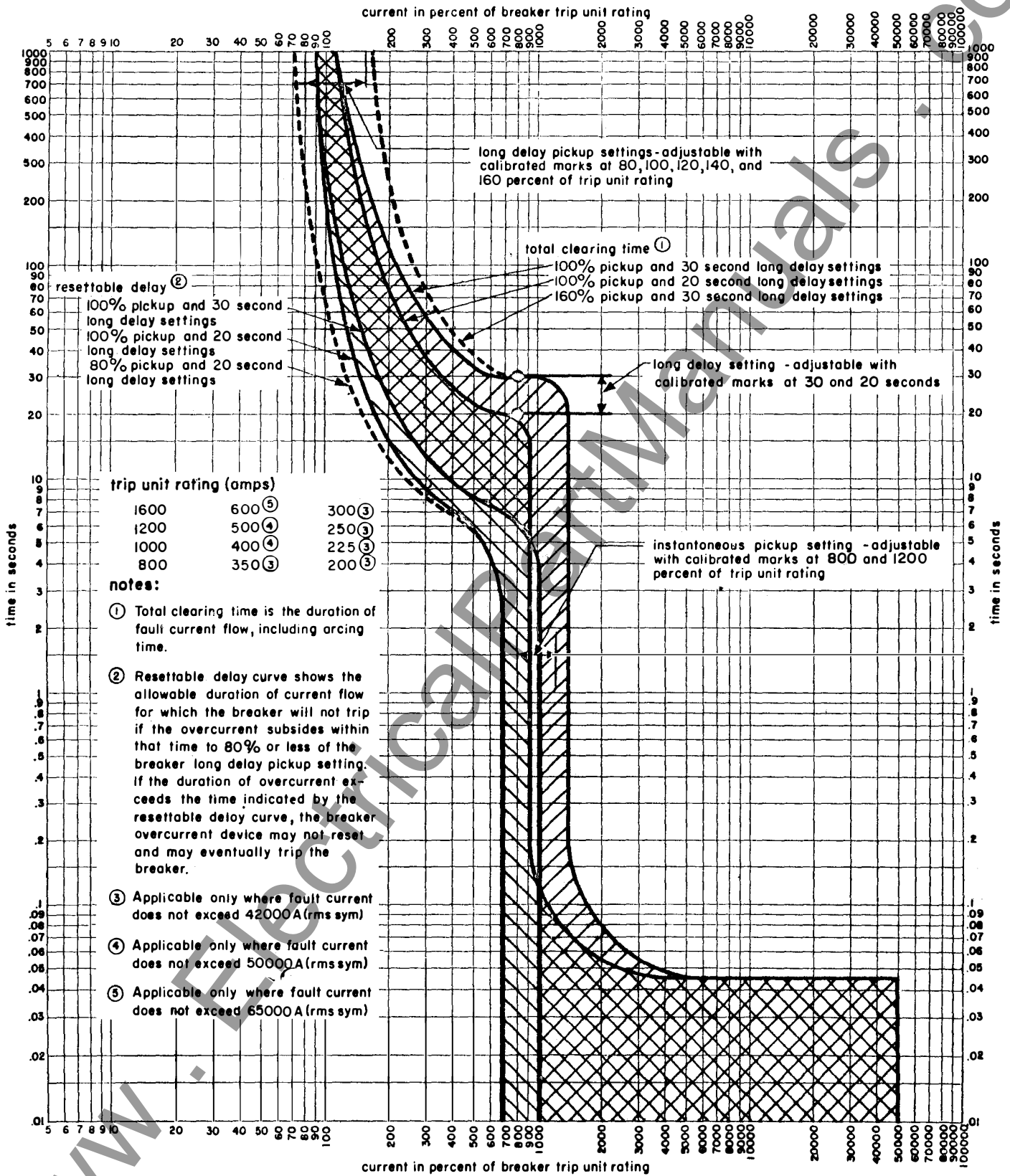

Fig. 7 - Tripping Characteristics of Standard Series Overcurrent Tripping Device with Long Delay and Instantaneous Elements

B. A quick release valve (shown in Fig. 6-short delay tripping parts) which functions as described for dual overcurrent tripping device.

C. Discriminator armature, Fig. 6.

D. Discriminator operating linkage.

The discriminator operating linkage, Fig. 13 and the discriminator armature, Fig. 6 are used on the selective overcurrent tripping device to make the device behave as an instantaneous type tripping device while the breaker is being closed and for approximately 0.5 seconds after closing. During this period, the discriminator armature is free to lift the quick release valve and permit instantaneous tripping, if the current is greater than the discriminator armature pick-up setting. If the current does not rise above this value, the breaker remains closed and the discriminator linkage assumes a position which makes the discriminator armature inoperable and restores the selective tripping feature to the tripping device.

3. Instantaneous Trip Only Device

The instantaneous trip only device, in principle, is the simplest of the three. As seen from Figure 12, the adjustable instantaneous trip is merely a modification of the adjustable long delay pick-up of the dual overcurrent series tripping device.

TIME-CURRENT CHARACTERISTICS

The time-current curve of this air delayed device has an inverse time characteristic up to approximately 600 percent of coil rating in the long delay range as shown in Figure 7. Within this range, the moving core and tripping stem move as a unit, that is, the magnetic pull has not increased sufficiently to overcome the loaded spring inside the moving core. Above 600 percent, the tripping time is essentially constant with increase in current. Within this region, the magnetic force is sufficient to overcome the spring inside the moving core at the outset, thereby subjecting the diaphragm to the constant force pattern of the spring.

The tripping time will remain constant until interrupted by the instantaneous or short delay pick-up wherever they occur. For the same reason, the tripping time in the short delay region remains constant with increasing current for a given setting of the short delay.

Adjustment of Calibration Settings

CAUTION: As a safety measure, the breaker should be disconnected from the circuit before making any adjustment.

1. Long Delay Pick-Up

The long delay pick-up can be adjusted by means of P, Figure 10, also shown in Figure 6. The unit has been calibrated and the calibration plate marked at five settings, namely 80, 100, 120, 140 and 160 percent of the coil rating. The pick-up was placed on the 100 percent setting before shipment. A different setting can be obtained by carefully turning the adjusting knob with the help of a small screwdriver inserted in the slots for that purpose.

2. Long Delay Calibration

The long delay can be adjusted by means of the long time adjusting dial S, Figure 10, also shown in Figure 6. The dial adjustment is limited to slightly less than one turn. Two points have been calibrated at the factory and are indicated by white marks on the outer edge of the dial. The dial has markings from 1 to 10. When the higher-numbered white mark on the dial coincides with the white indicator on the front of the lower case, the tripping time will be the higher long delay value shown in seconds on the scale plate. Conversely, when the lower-numbered white mark on the dial coincides with the white indicator on the front of the lower case, the tripping time will be the lower long delay value shown in seconds on the scale plate. These tripping times are calibrated with currents which are 600 percent of the coil rating applied. The dial settings are scribed on the scale plate under long delay dial setting heading.

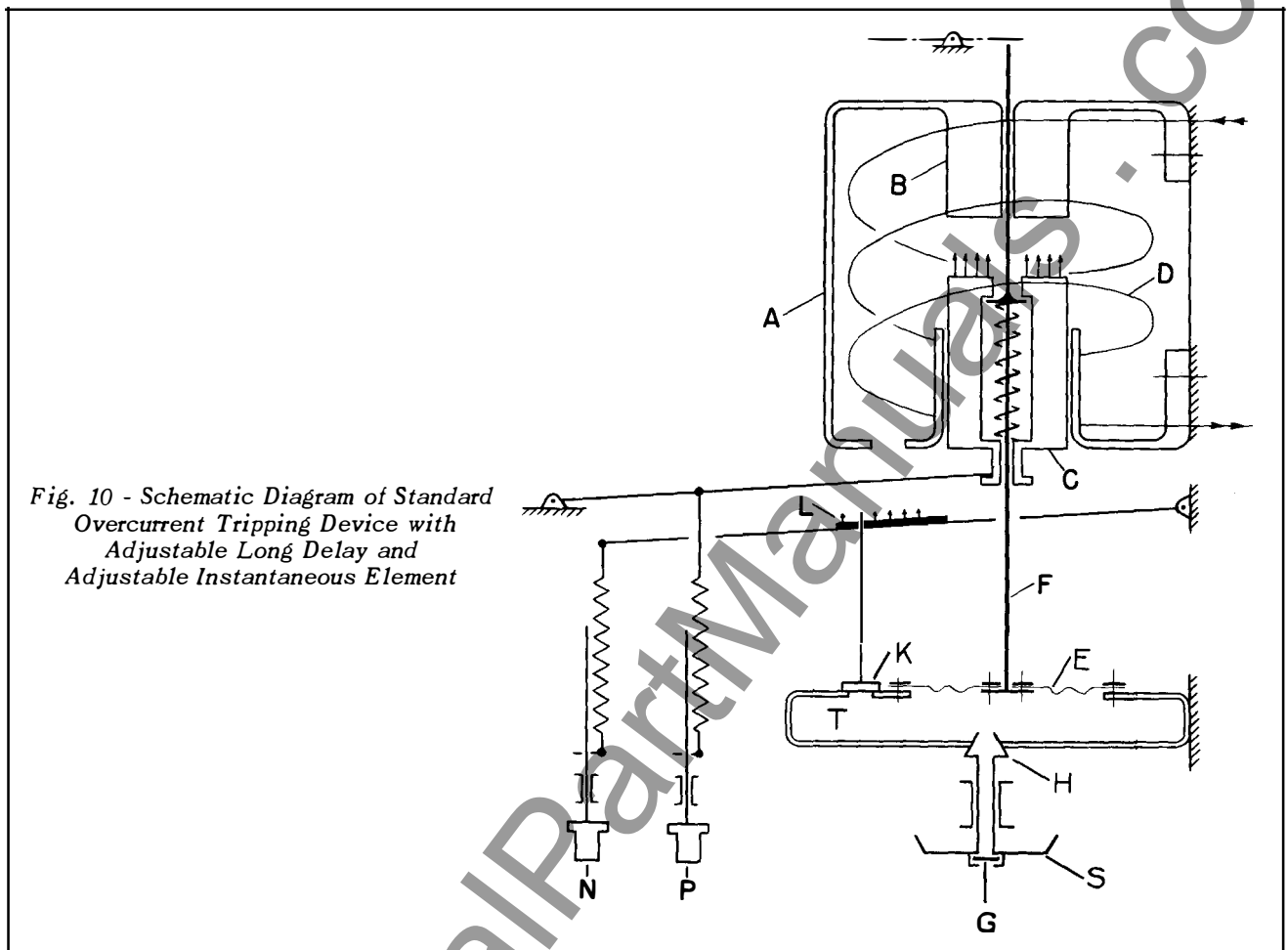

Fig. 10 - Schematic Diagram of Standard Overcurrent Tripping Device with Adjustable Long Delay and Adjustable Instantaneous Element

chamber T by the various valves H and K. When the diaphragm has reached approximately 60 percent of its travel, a quick release valve (shown in Fig. 6) is mechanically opened. This quick release feature permits the full force of the magnet to be used for tripping the breaker after the timing cycle is completed. At higher currents when the attraction between the moving core C and the stationary core B is greater than the load on the spring inside of the moving core, the moving core will compress the spring and travel independently of the tripping stem F. This spring insures a constant force pattern acting on the diaphragm E. The reset valve is shown as G.

Valve H is the long delay valve and it is permanently open to a calibrated setting. This setting which controls the tripping time can be changed by means of dial S, Figure 10. The magnitude of current at which the

long delay will begin to operate is determined by the long delay pick-up adjusting knob P, Figure 10. The magnitude of current at which the instantaneous trip will operate is determined by the instantaneous pick-up adjusting knob N, Figure 10.

2. Dual Selective Overcurrent Series Tripping Device For Group or Tie Breakers

The operation of the dual selective tripping device is similar to that of the dual overcurrent tripping device except that for this device the following details are included:

A. A short delay valve J, Fig. 11, controls the size of orifice and consequently the tripping time in the short circuit region. This orifice is adjustable by means of knob R.

www.ElectricalPartManuals.com

Recommended Spare Parts for

NAME OF PART (ALWAYS GIVE BREAKER S.O. REFERENCE)	STYLE NUMBER OR REFERENCE	NUMBER PER BREAKER OR DEVICE	NUMBER RECOMMENDED		
			FOR BREAKERS		
			1	2 TO 5	6 UP
AUXILIARY SWITCH	FIG. 21				
4 POLE SWITCH UNIT	NO. 187	1 OR 2	-	1	2
FRONT COVER	NO. 186	1	-	-	1
CONTACT FINGER 184	1397624	8	-	4	8
CONTACT ROTOR 185	1397641	4	-	4	8
CONTROL RELAY	FIG. 15				
OPERATING COIL	NO. 166	1	-	1	2
BLOWOUT COIL & CIRCUIT-DC	NO. 161	1	-	1	2
MOVING CONTACT-LEFT POLE	NO. 153	1	-	2	4
MOVING CONTACT-RIGHT POLE	NO. 163	1	-	1	2
STATIONARY CONTACT-LEFT POLE	NO. 160	1	-	2	4
STATIONARY CONTACT-RIGHT POLE	NO. 165	1	-	1	2
COVER	NO. 159	1	-	-	1
POLE UNIT	FIG. 3				
STATIONARY ARCING CONTACT	NO. 314	3	3	6	12
STATIONARY MAIN CONTACT	NO. 313	3	-	1	3
MOVING ARCING CONTACT	NO. 301	3	3	6	12
MOVING MAIN CONTACT	NO. 312	6	-	2	4
AUXILIARY MAIN CONTACT	NO. 310	12	-	2	4
ELECTRIC OPERATION					
CLOSING COIL	FIG. 3 NO. 304	1	-	1	2
SHUNT TRIPPING COIL	FIG. 16 NO. 320	1	-	1	2
OVERCURRENT DEVICE COMPLETE	FIG. 6	3	-	1	2
RETAINING RINGS ASSORTMENT	497A346G03	1	1	2	3

www.ElectricalPartManuals.com

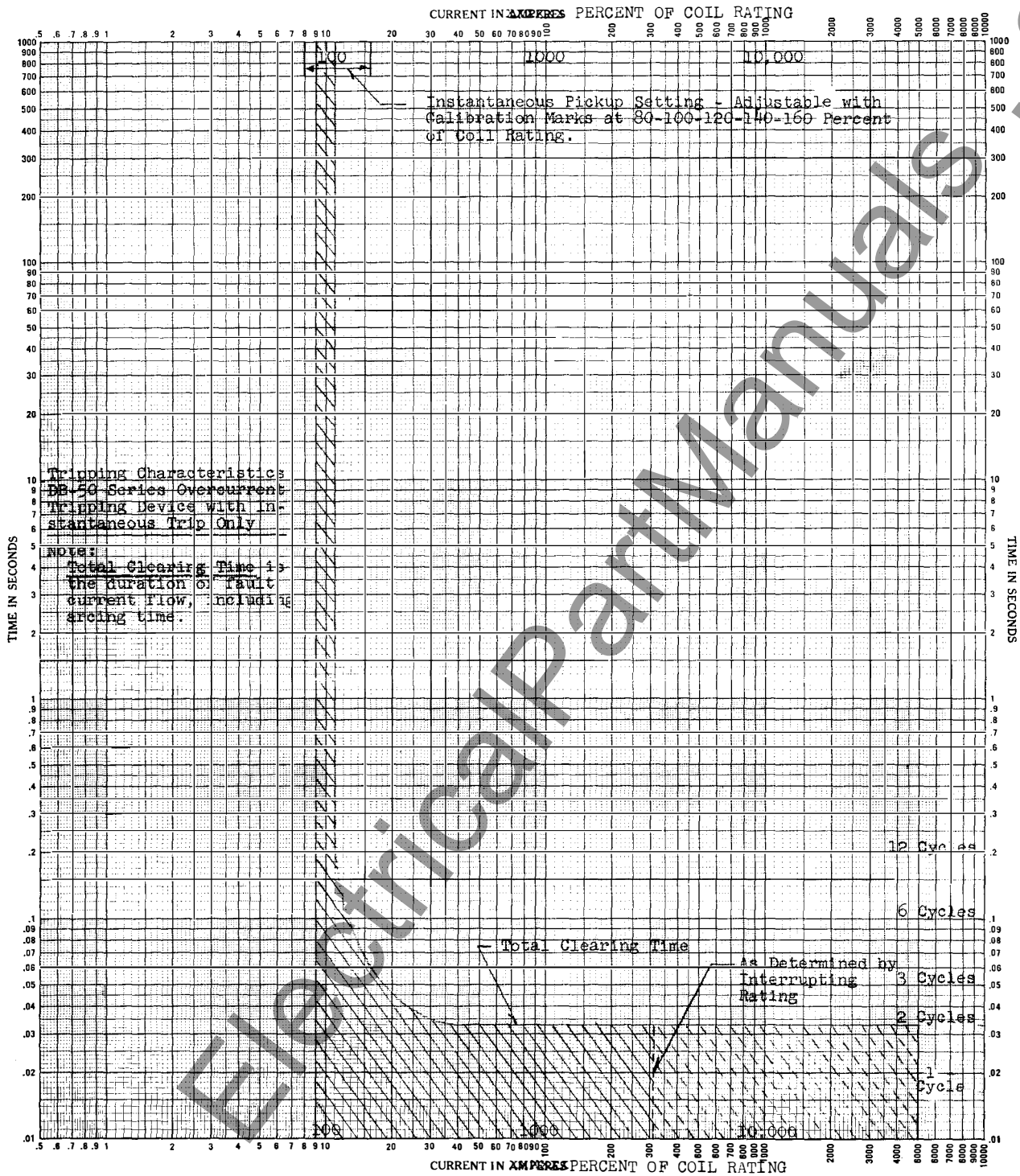

Fig. 9 - Tripping Characteristics of Special Series Overcurrent Tripping Device with Instantaneous Element Only

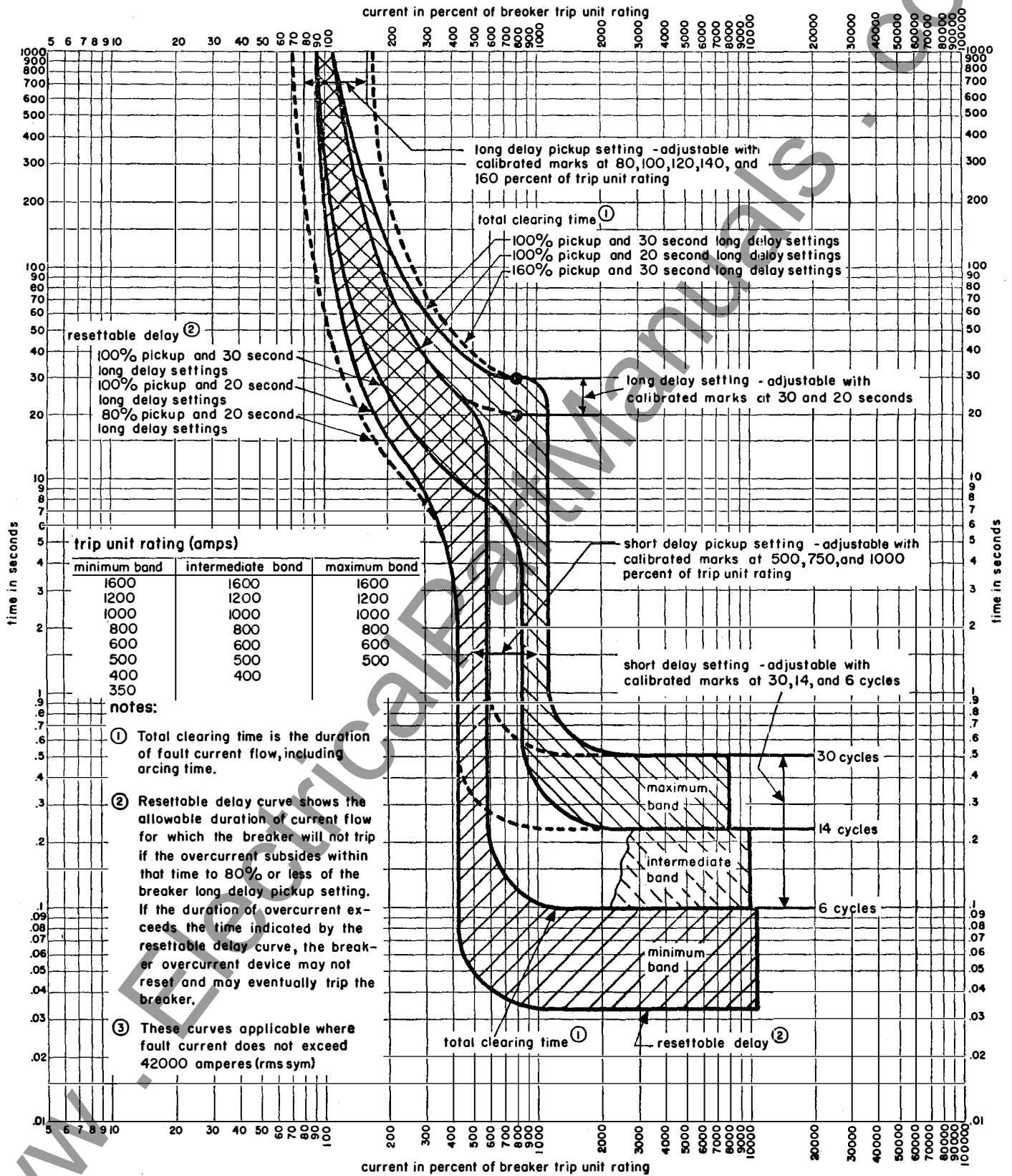
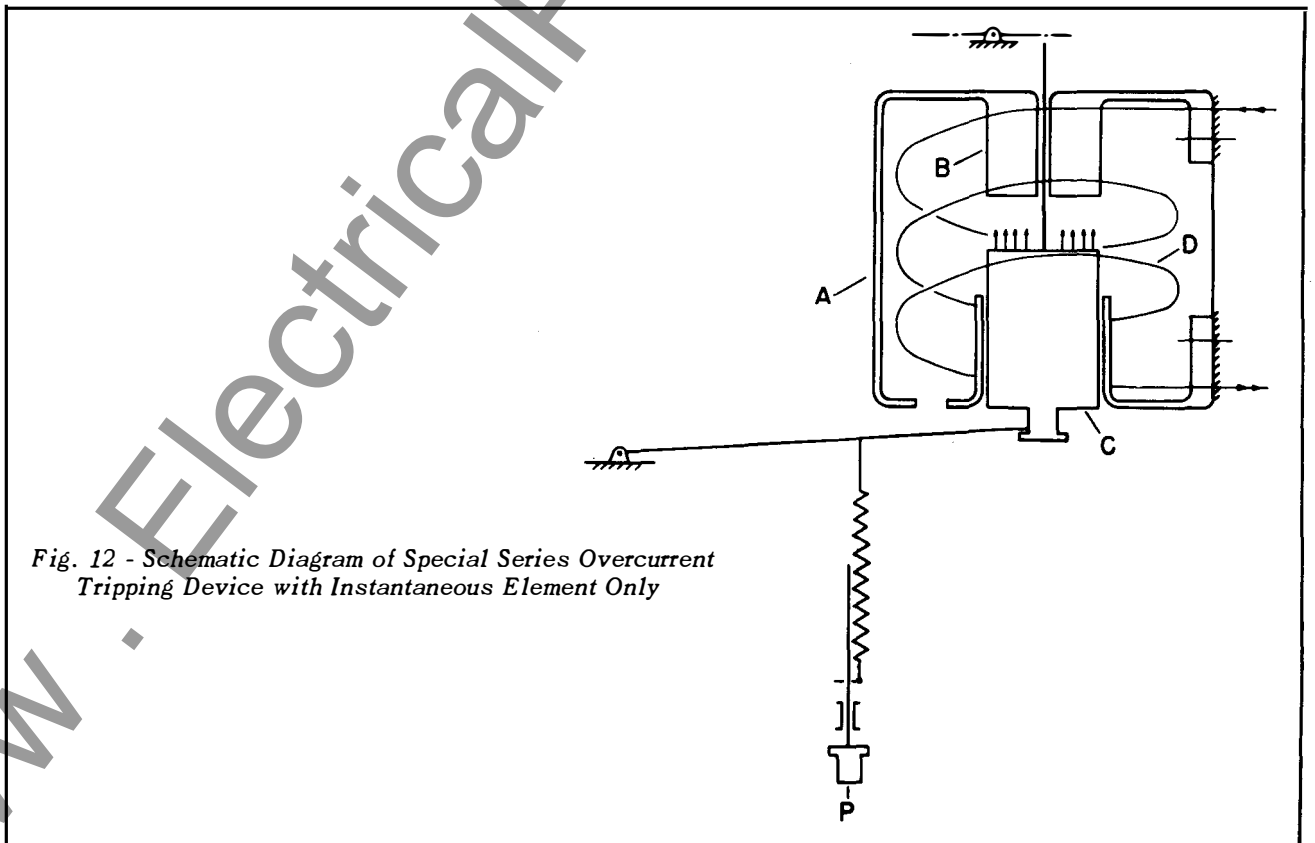
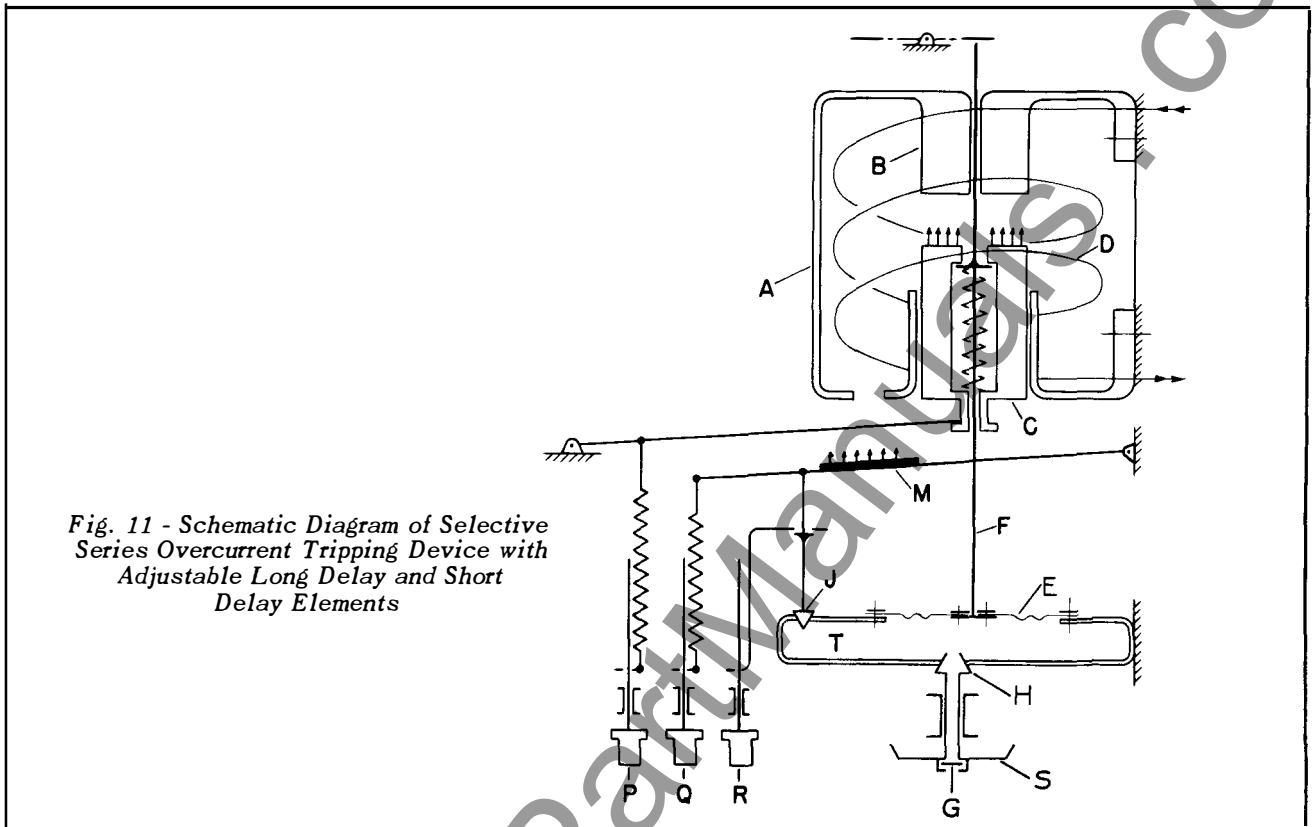

Fig. 8 - Tripping Characteristics of Selective Series Overcurrent Tripping Device with Long Delay and Short Delay Elements



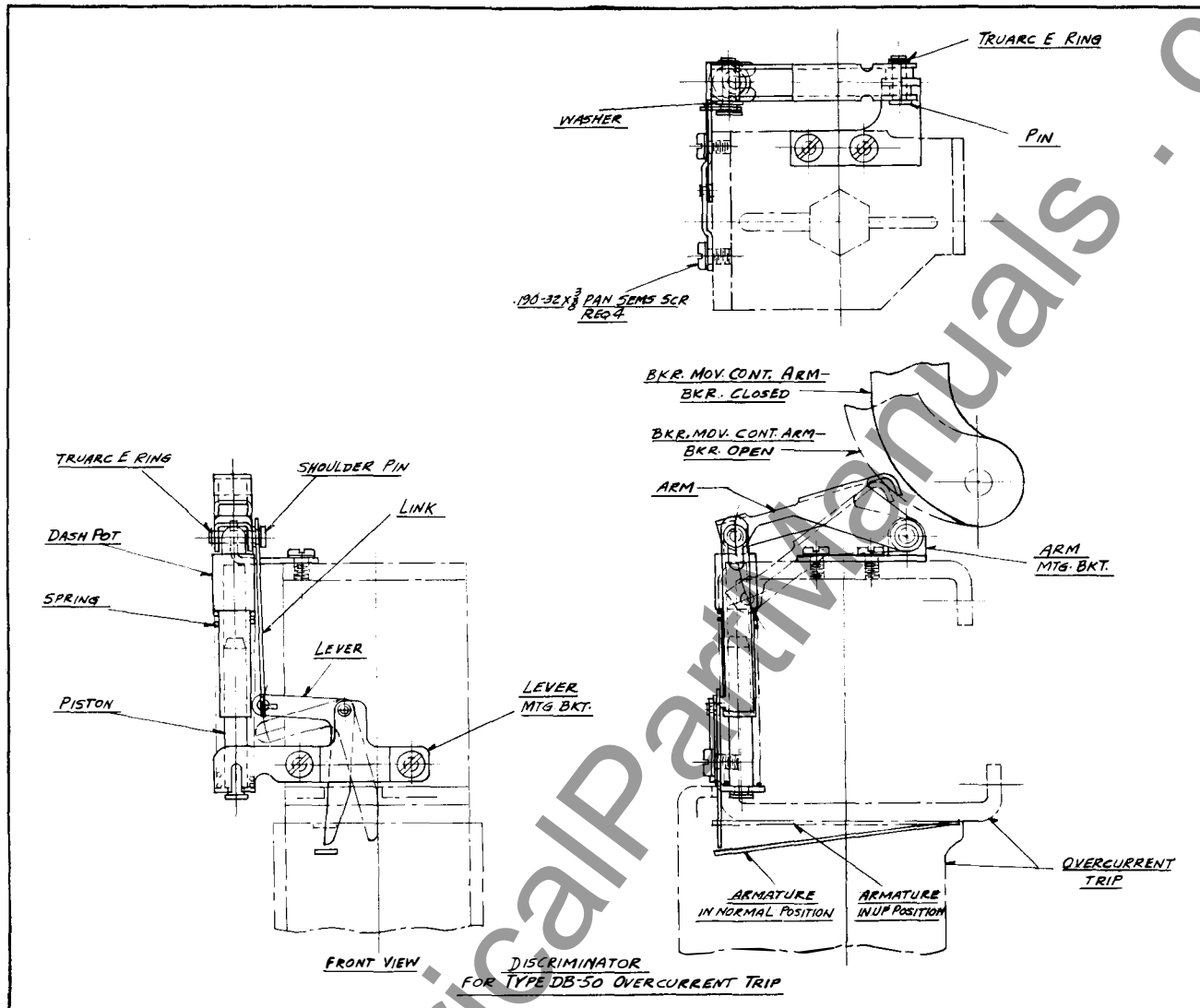

Fig. 13 - Discriminator for Tripping Device

3. Instantaneous Pick-Up

The instantaneous pick-up can be adjusted by means of knob N, Figure 10, also shown in Figure 6. The instantaneous pick-up has been calibrated at 8 and 12 times or 5 and 10 times the coil rating at the factory. The adjusting knob can be turned carefully with the help of a small screwdriver inserted in the slots for that purpose, if a different setting is desired.

4. Short Delay Pick-Up

The short delay pick-up can be adjusted by means of knob Q, Fig. 11. The unit has

been calibrated and the calibration plate marked at 500-750 and 1000 percent of the coil rating. The pick-up is usually placed on the 750 percent setting before shipment. A different setting can be obtained by carefully turning the adjusting knob with the help of a small screwdriver inserted in the slots for that purpose.

5. Short Delay Calibration

The short delay can be adjusted by means of knob R, Fig. 11. The unit has been calibrated and the calibration plate marked at 6-14 and 30 cycles. The short delay is usually placed on the 14 cycle

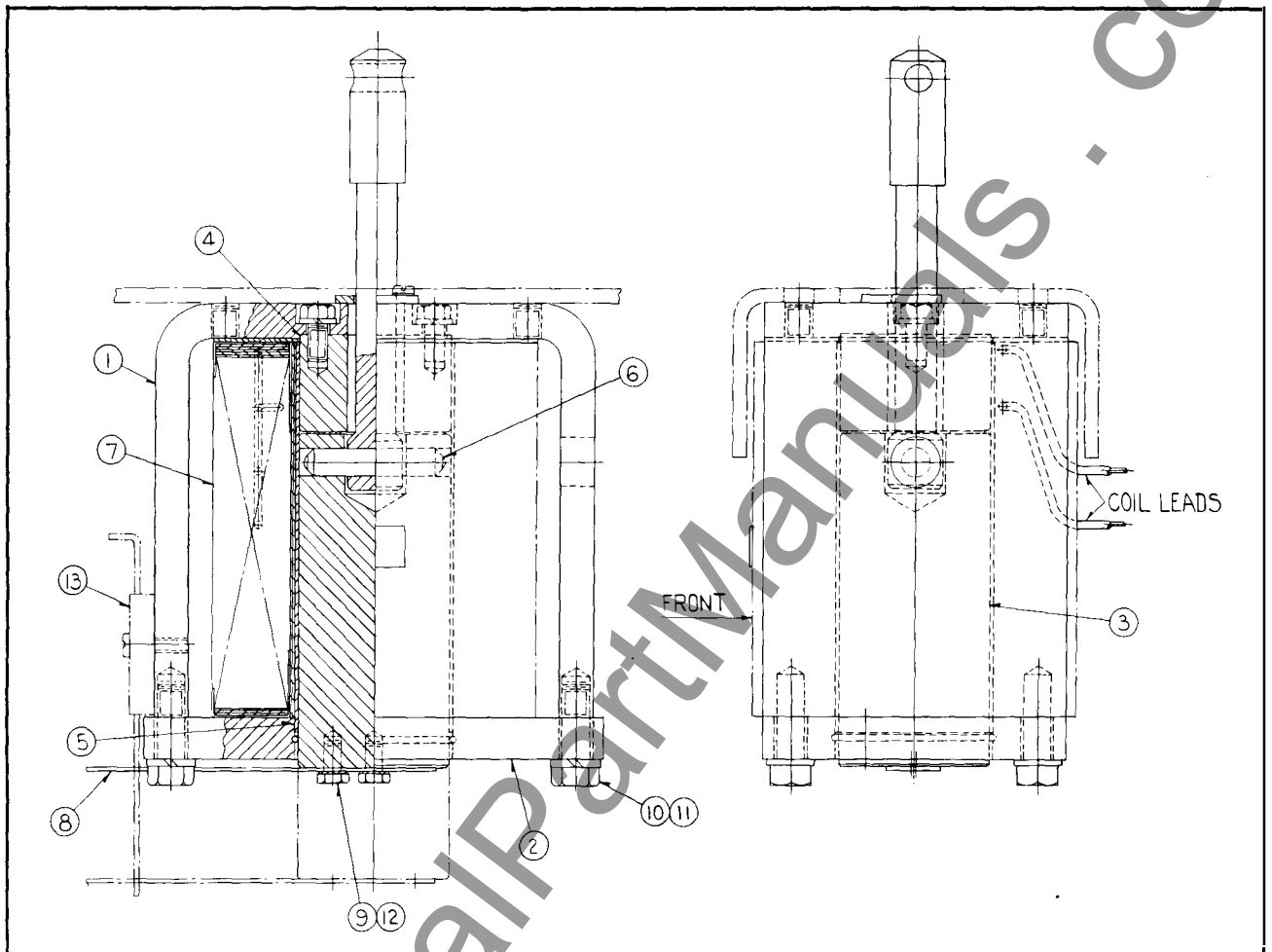

Fig. 14 - Closing Solenoid - Construction Details

setting before shipment. A different setting can be obtained by carefully turning the adjusting knob with the help of a small screwdriver inserted in the slots for that purpose.

6. Instantaneous Only Pick-Up

The instantaneous pick-up can be adjusted by means of knob P, Fig. 12. The unit has been calibrated and the calibration plate marked at 80-100-120-140 and 160 percent of the coil rating. The pick-up is usually placed on the 100 percent setting before shipment. A different setting can be obtained by carefully turning the adjusting knob with the help of a small screwdriver in the slots for that purpose.

CONTROL RELAY

The control relay (see Fig. 15) mounts directly under the auxiliary switch. It is a single-coil, mechanically-tripped device with the coil suitable for continuous energization. The operation sequence is outlined in Fig. 2, Page 10. The contacts should normally last the life of the breaker, but are replaceable if found necessary.

The relay trip assembly may be checked for correct operation of the relay and the relay release arm as follows: (Refer to Fig. 15.) Disconnect the closing coil leads from the control circuit wiring.

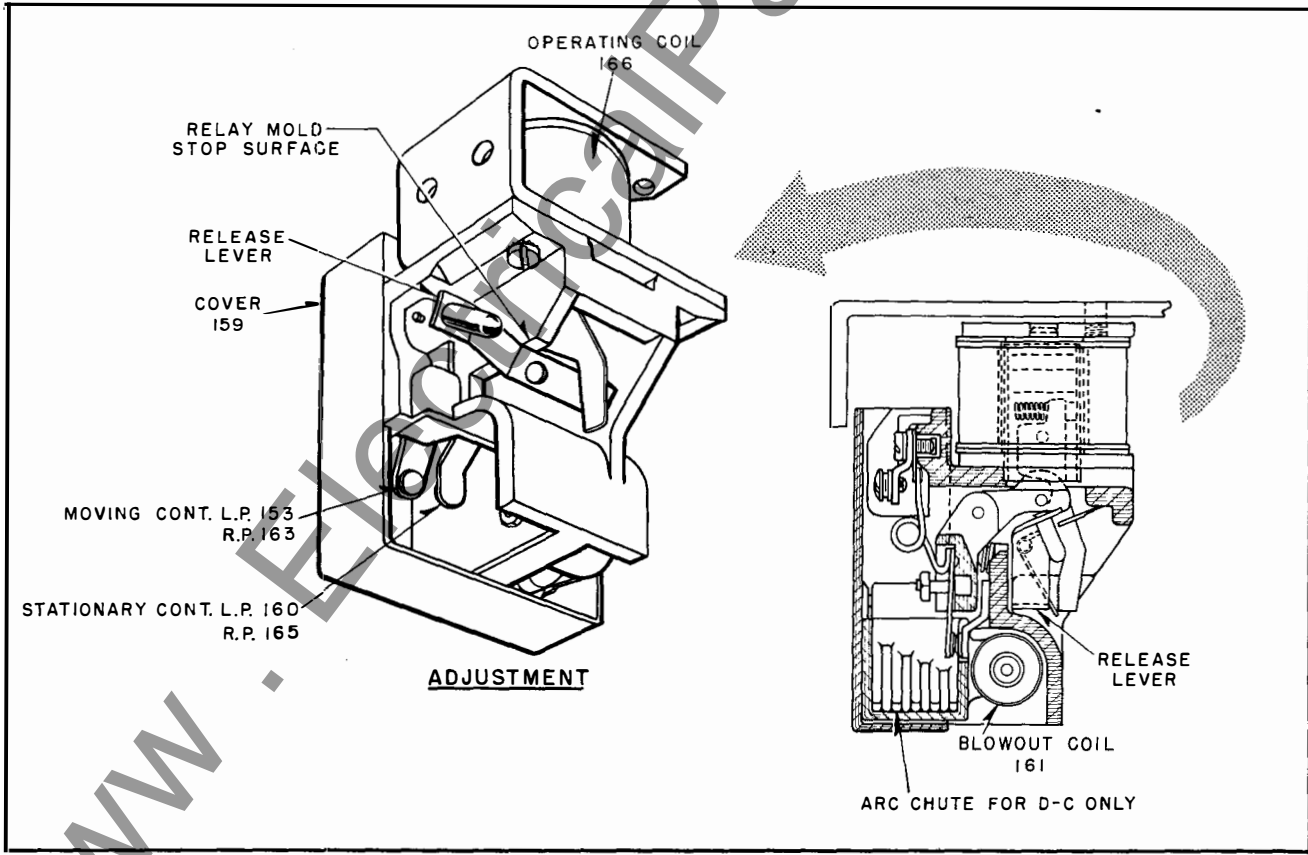
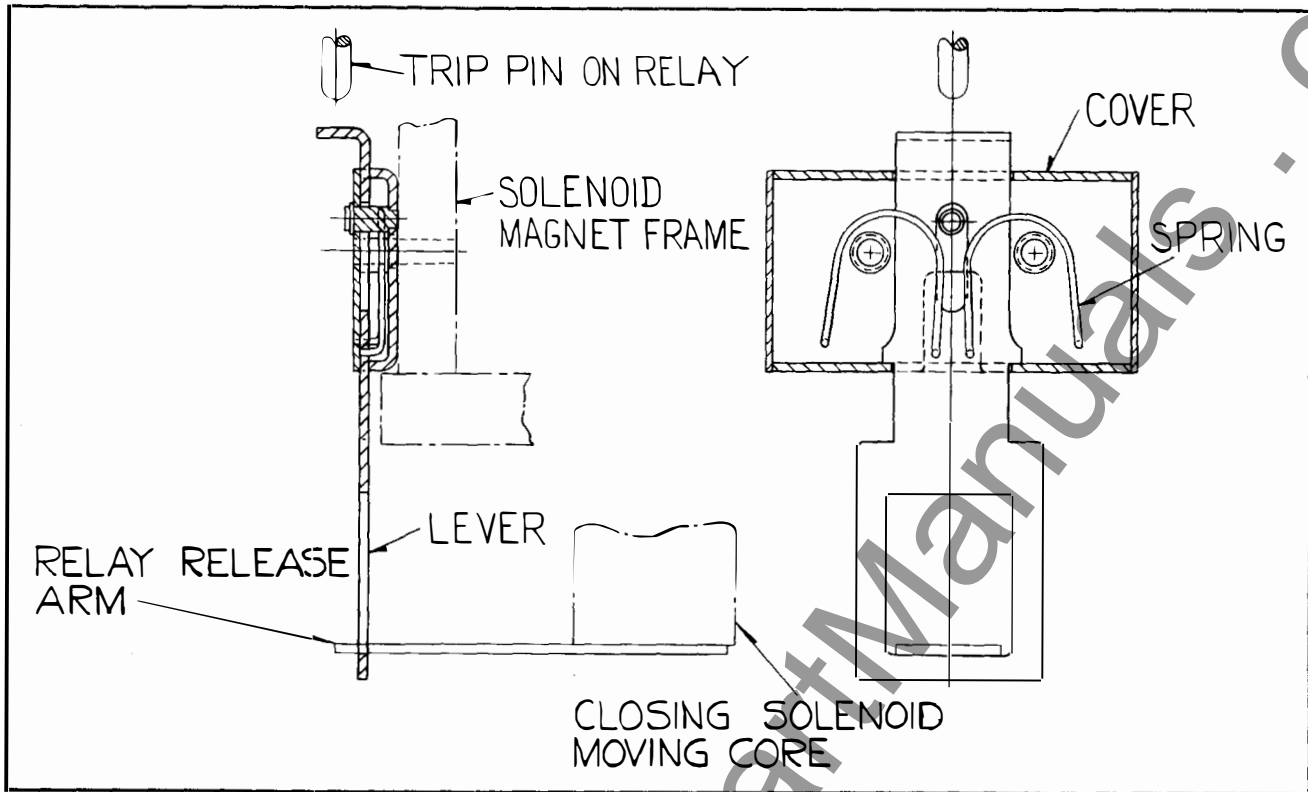

Fig. 15 - Control Relay - Adjustment and Construction Details

Energize relay operating coil. Slowly close the breaker manually. The relay release arm should operate the relay trip assembly and the relay trip assembly should open the relay contacts just before the breaker latches. This position can best be determined by watching the pawl in the breaker operating mechanism, which should snap in place just after the relay contacts open. If this operation sequence is not correct, the relay release arm should be bent to suit. Make sure that the relay release arm does not rub on either side of the relay trip assembly lever aperture. When the breaker is latched, de-energizing and then energizing the relay operating coil should not cause the relay contacts to move toward the closed position. Trip breaker.

Reconnect closing coil leads to the control circuit wiring. Check electric closing of breaker.

SHUNT TRIP ATTACHMENT

The shunt trip mounts on top of the platform immediately to the right of the operating mechanism. (See Fig. 16.)

It is non-adjustable and is intended for intermittent duty only. The shunt trip circuit must always be opened by an auxiliary switch contact. Tripping currents are tabulated in Table No. 2, Page 7.

Inspection

With the breaker in the open position, manually push the moving core against the stationary core and rotate the breaker handle to the closed position. The breaker should be trip free.

The trip lever of the shunt trip should have from 1/32 to 1/8-inch clearance to the trip bar.

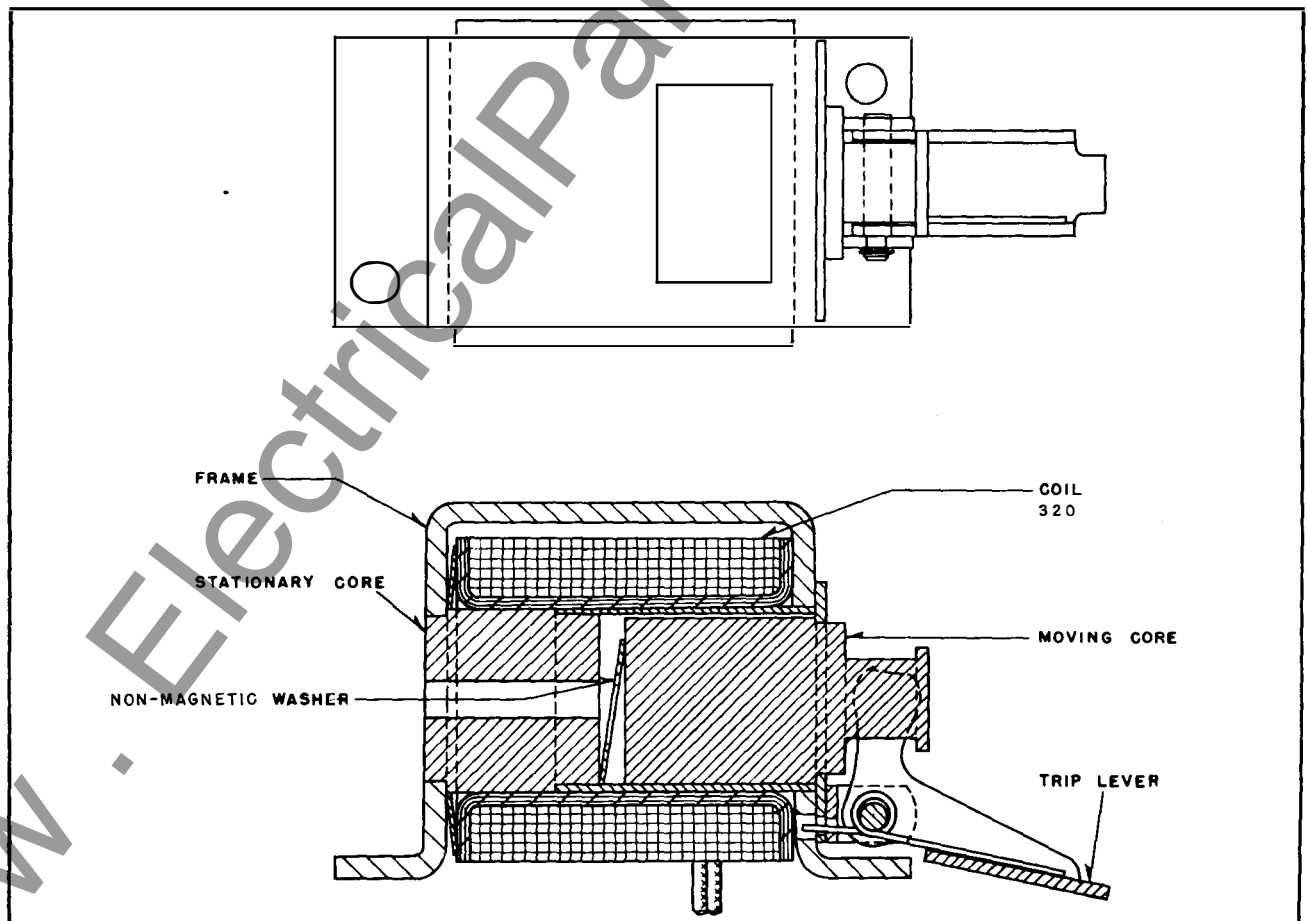

Fig. 16 - Shunt Trip Attachment - Construction Details

Maintenance

Check for loose bolts and faulty coil.

UNDERVOLTAGE TRIP ATTACHMENT

The undervoltage trip mounts on top of the platform, to the right of the shunt trip. (See Fig. 17.) Its function is to trip the breaker when the voltage falls to between 30 to 60 percent of normal.

The moving core is normally held magnetically against the stationary core to hold the rod and consequently the reset lever in the reset position. When the coil voltage is reduced sufficiently, the reset lever spring overcomes the magnetic attraction of the cores and rotates reset lever clockwise. As reset lever rotates, pin pushes against the latch to release it from its latch plate. When the latch releases, the trip spring rotates the trip lever counterclockwise to trip the breaker. The linkage is reset by the cross bar as the breaker opens.

Always connect the coil to the line side of the breaker unless the attachment is equipped with a time delay device. In this case, the time delay will delay the tripping of the breaker long enough to permit energization of the undervoltage coil from the load side. Do not use an auxiliary switch contact in the undervoltage circuit.

UNDERVOLTAGE TIME DELAY ATTACHMENT

The undervoltage air dashpot time delay attachment mounts on the front of the undervoltage trip, replacing moving core cover. (See Fig. 17.) The needle valve screw in the top regulates the opening through which the air is forced and hence the time delay. (See Fig. 18.) The attachment does not have a quick reset feature and therefore approximately one minute should be allowed between operations to permit complete resetting. It is set to trip within 4 to 7 seconds.

Inspection

Hold the trip bar down and close the breaker manually. Release the trip bar slowly, allowing the undervoltage trip spring to raise the trip bar and trip the breaker.

Maintenance

Check for loose bolts and faulty coils.

REVERSE CURRENT TRIP ATTACHMENT

This attachment mounts directly on the center molded pole unit base, in the space ordinarily occupied by the overcurrent attachment. (See Fig. 19.) It is used to trip the breaker when the direction of current flow in that pole is reversed. When the series coil current is flowing in the forward direction, armature movement is prevented by a stop. When the series coil current is reversed, the armature rotates in the opposite direction to trip the breaker. Calibration adjustment covers 5 and 25 percent reverse current, based on normal current rating.

After tripping the reverse current armature is reset by opening the potential coil circuit. For this purpose an "a" contact of the breaker auxiliary switch should be connected in series with the potential coil.

Inspection

Close the breaker manually, and push backward on the spring stud located on the bottom of the armature, to trip the breaker. The armature should move without friction, and should have approximately 1/32-inch overtravel after tripping.

Final inspection should be made electrically, after the circuit connections are complete as shown in Fig. 2, Page 10.

Maintenance

Remove all power from the breaker and repeat the mechanical inspection given above. Check for loose bolts and open circuit in potential coil.

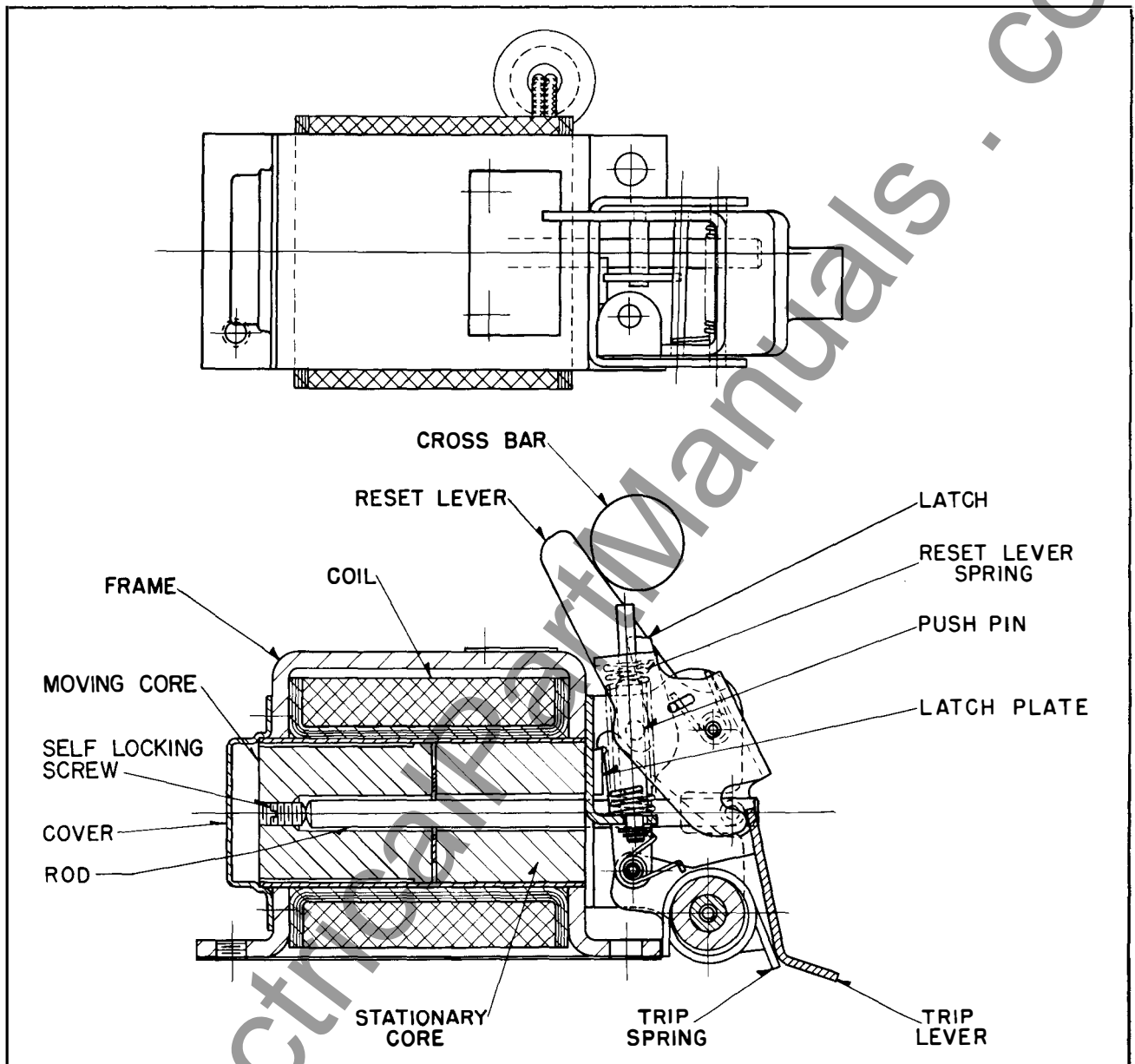

Fig. 17 - Undervoltage Trip Attachment - Construction Details

FIELD DISCHARGE SWITCH

The DBF-16 breaker is a two-pole DB-50 breaker having special arc chutes and modified arcing contacts plus a field discharge switch mounted on the center pole (Fig. 20).

The field discharge switch is shipped with the gap setting shown in Fig. 20, for generator field protection. However, the gap setting can be reduced to zero or set to open after the breaker contacts close, if

desired. An arc chute is always supplied to interrupt motor starting secondary currents.

Inspection

Remove the arc chute, close the breaker manually and check for freedom of motion. The break distance is adjusted by loosening the lock nut and turning the sleeve in or out. Always leave a slight gap at the stop surface.

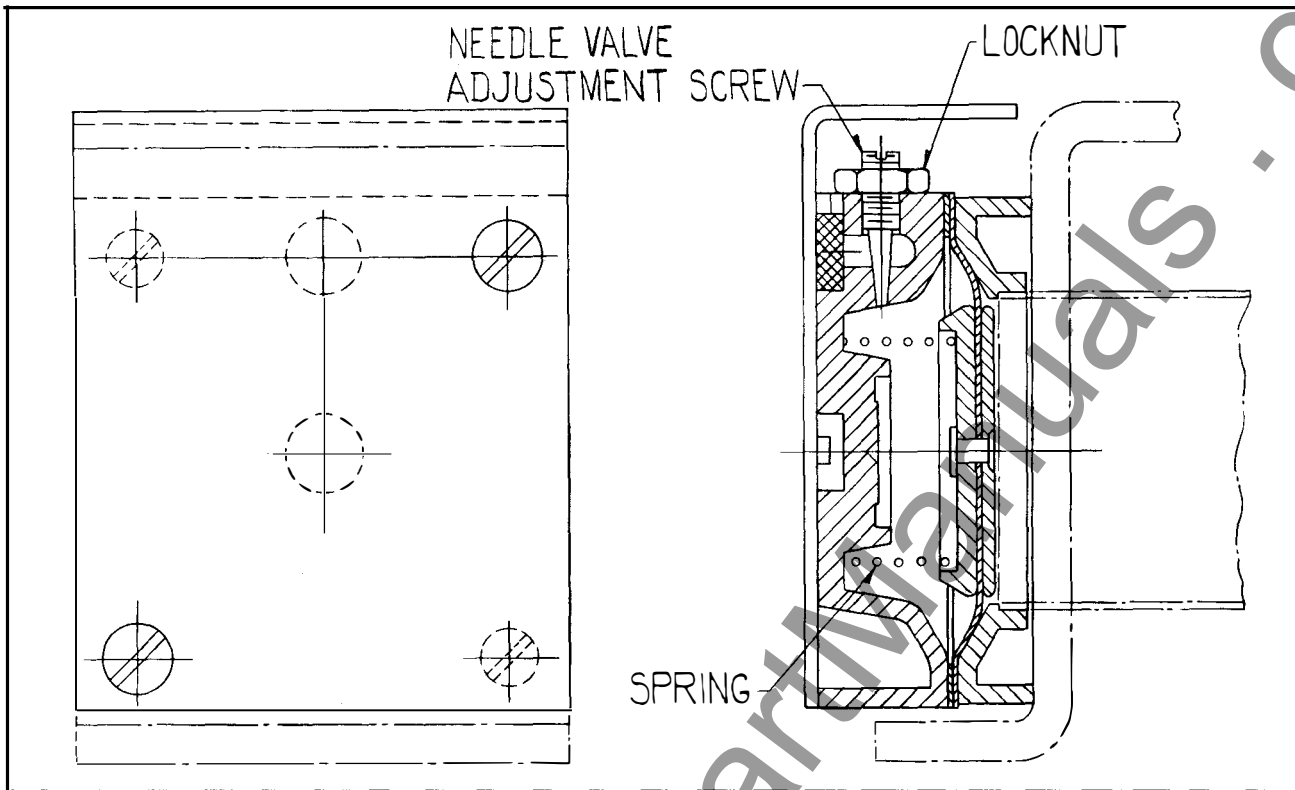

Fig. 18 - Undervoltage Time Delay Attachment - Construction Details

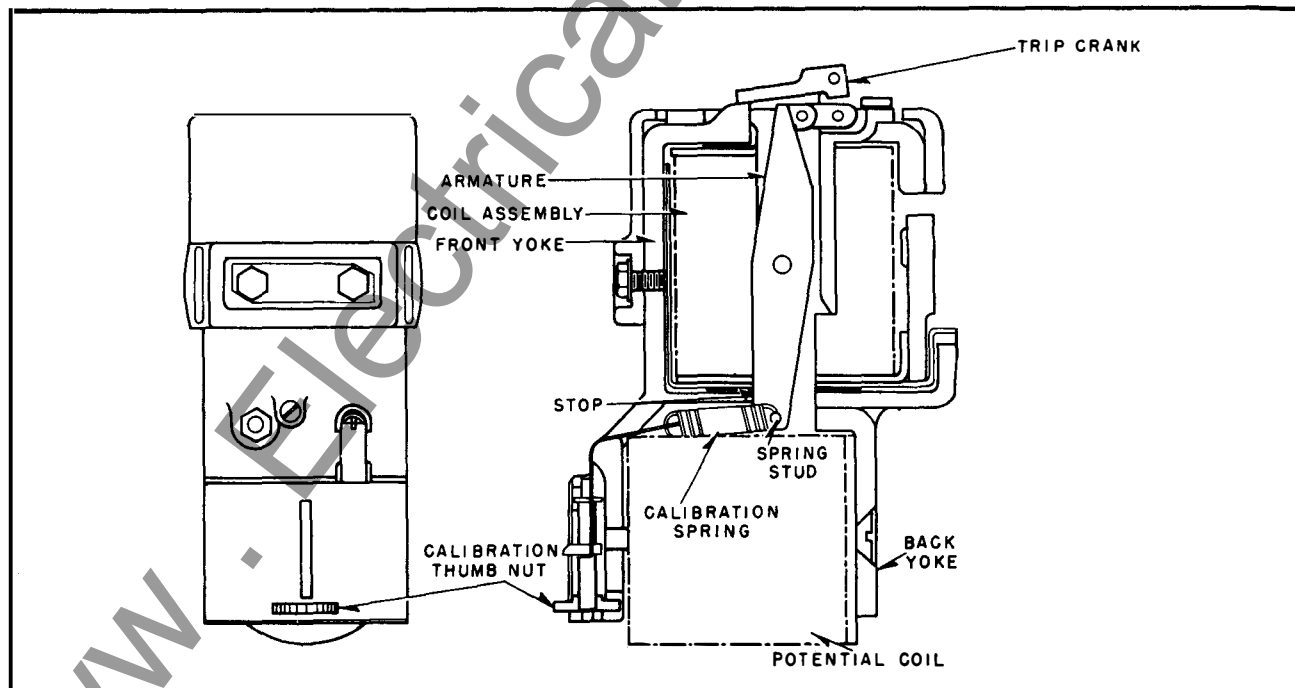

Fig. 19 - Reverse Current Trip Attachment - Construction Details

Maintenance

Remove power from the breaker, clean the contacts if necessary, check the contact separation and adjust if necessary. Check for loose bolts.

AUXILIARY SWITCH

The auxiliary switch mounts on top of the platform to the left of the operating mechanism. (See Fig. 21.) The contacts will carry 15 amperes continuously or 250 amperes for 3 seconds.

TABLE NO. 3
Interrupting Capacity

VOLTS	INTERRUPTING CAPACITY IN AMPERES	
	NON-INDUCTIVE CIRCUIT	INDUCTIVE CIRCUIT
125 V. D-C	11	6.25
250 V. D-C	2	1.75
115 V. A-C	75	15
450 V. A-C	25	5

The switch is a shaft-operated, 4-pole, rotary type having two "a" contacts (closed when the breaker is closed) and two "b" contacts (closed when the breaker is open). The rotor operates through a 90-degree angle and is non-adjustable however, the contacts may be changed from "a" to "b" or vice versa. To change, remove the switch from the platform, remove the back cover, shaft and end bushing. Remove the rotor and change the contacts as desired. Be sure to replace the shaft in the original position relative to one of the unchanged contacts.

Inspection

Remove front cover and make sure contacts are touching well before the end of travel.

Maintenance

Check for loose bolts. Replace contacts if necessary.

ALARM SWITCH ATTACHMENT

The alarm switch mounts above the shunt trip attachment (see Fig. 22) and will energize the alarm circuit on all opening operations excepting those initiated through the push-to-trip button or shunt trip. The alarm switch may be reset manually by operating the push-to-trip button or electrically by energizing the shunt trip coil (when electrical resetting has been provided). Manually or electrically closing breaker also resets alarm switch.

Inspection

Close the breaker manually and trip by means of push-to-trip button to be sure the contacts do not "make". Repeat the above procedure except trip by raising the trip bar and note that the alarm contacts do make contact.

Maintenance

Clean the alarm contacts when necessary. Check for loose bolts.

ELECTRIC LOCKOUT ATTACHMENT

The electric lockout mounts on the top of the platform immediately to the left of the operating mechanism and behind the auxiliary switches. (See Fig. 23.) Its function is to hold the breaker open (trip free) until the lockout coil is energized. The lockout coil can be de-energized after closure of the breaker, if desired.

Inspection

Rotate the breaker handle to the closed position. The lockout should prevent closure of the breaker by holding the trip bar in the trip free position. Holding the lockout armature in the closed position should permit closure of the breaker. Releasing the armature after closure should not trip the breaker.

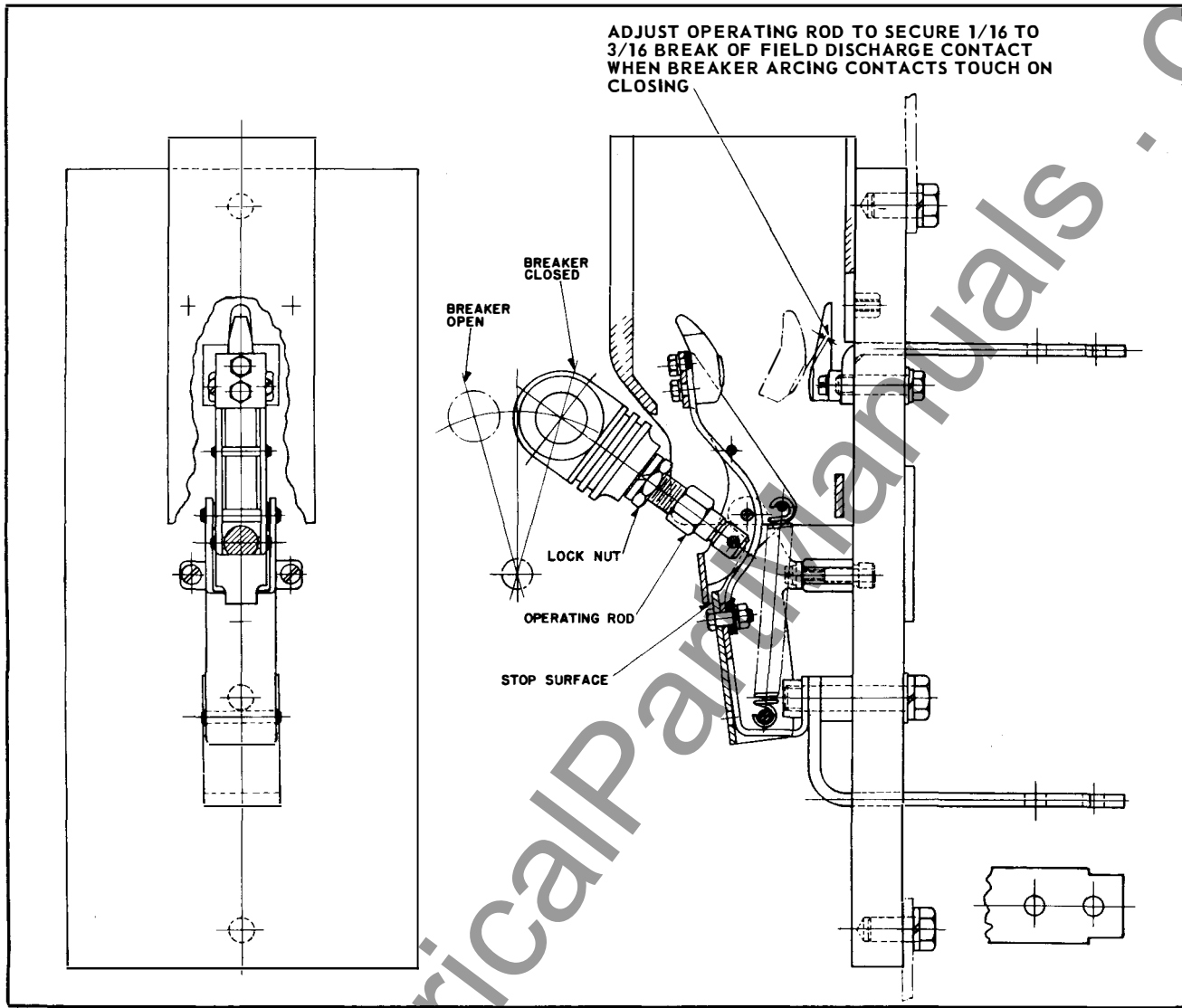

Fig. 20 - Field Discharge Switch - Construction Details

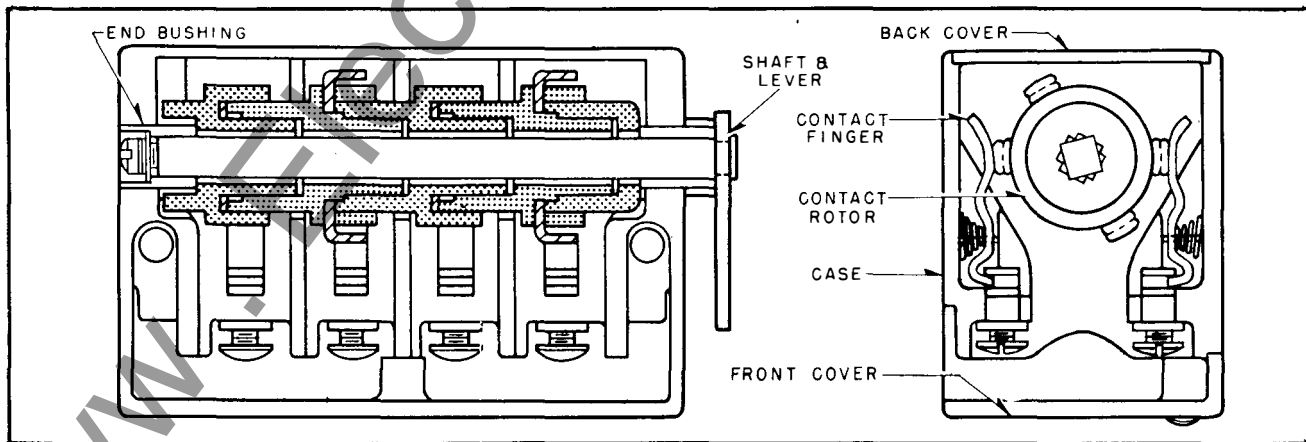

Fig. 21 - Auxiliary Switch - Construction Details

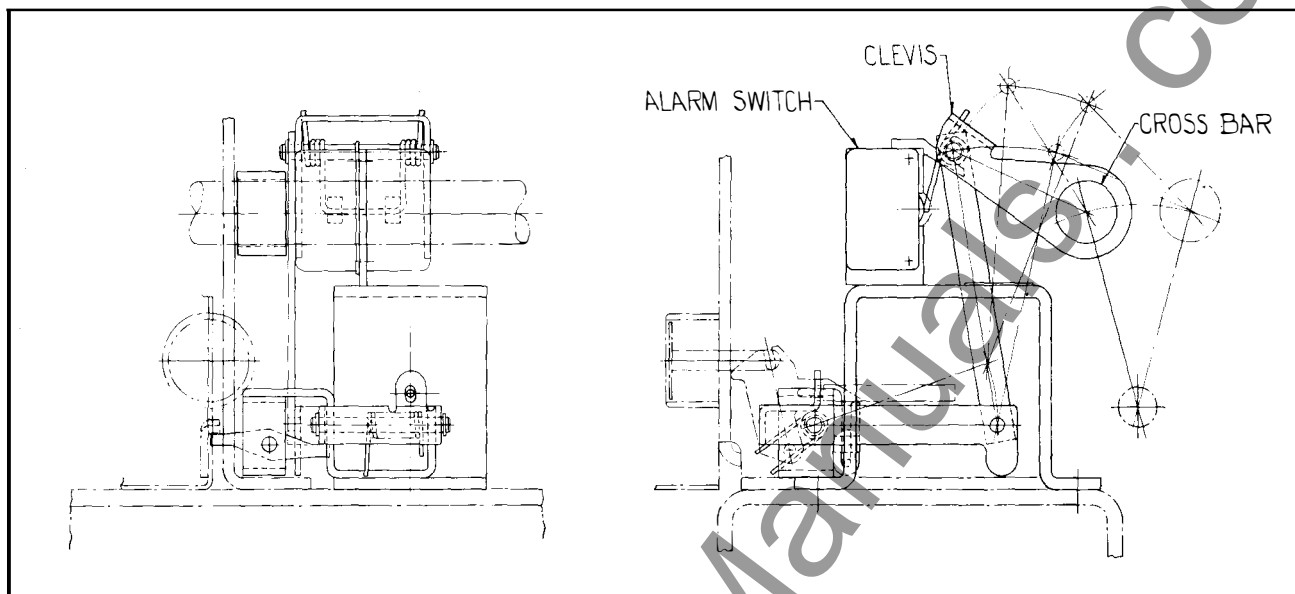

Fig. 22 - Alarm Switch Attachment - Construction Details

Maintenance

The device is non-adjustable. Check for open-circuited coil and for loose bolts.

KEY LOCK ATTACHMENT

The key lock mounts on the right side of the operating mechanism frame. (See Fig. 24.) The key can be removed in the open or closed position of the breaker.

Inspection

Push the trip button and turn key to the locked position. The key is then removable and the breaker is locked in the tripped position. Replace key and rotate to the unlocked position to free breaker trip button. The key is also removable in this position.

Maintenance

The device is non-adjustable. Check for loose bolts only.

KEY INTERLOCK ATTACHMENT

The key interlock mounts on the right side of the operating mechanism frame. (See

Fig. 24.) When the key interlock attachment is furnished, the key lock attachment cannot be supplied. In the key interlock attachment the key cannot be removed unless the breaker is locked in the tripped position.

Inspection

Push the trip button and turn the key to the locked position. The key is then removable and the breaker is locked in the tripped position. Replace the key and rotate to the unlocked position to free the breaker trip button. The key is not removable in this position.

Maintenance

The device is non-adjustable. Check for loose screws and nuts only.

RECTIFIER UNIT FOR A-C UNDERVOLTAGE AND A-C ELECTRIC LOCKOUT ATTACHMENTS

When an a-c undervoltage attachment is required or an a-c electric lockout attachment is required or both attachments are required, a rectifier unit is mounted underneath the breaker platform under the undervoltage device as shown in Fig. 25. An auto-transformer is provided in the unit so

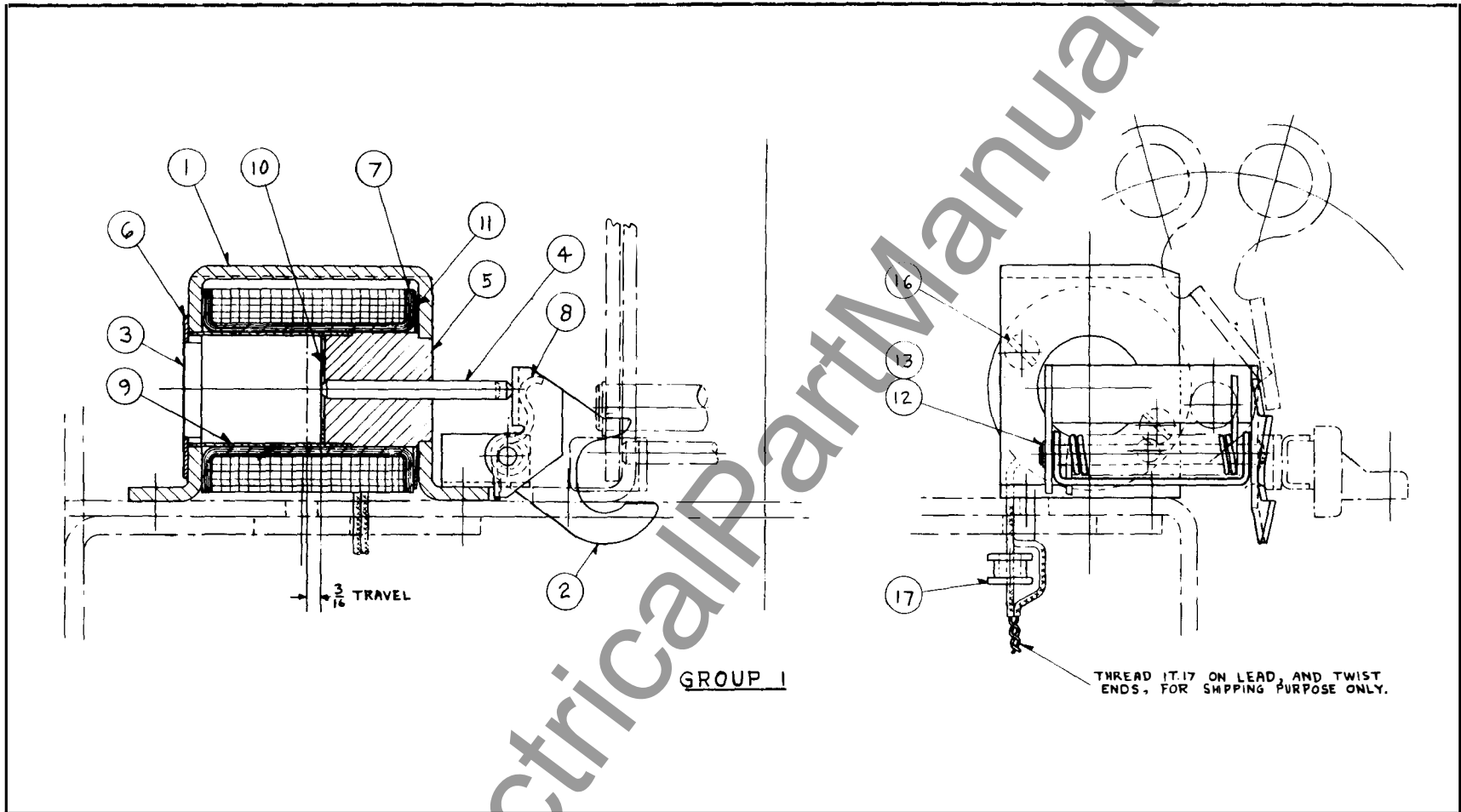

Fig. 23 - Electric Lockout Attachment - Construction Details

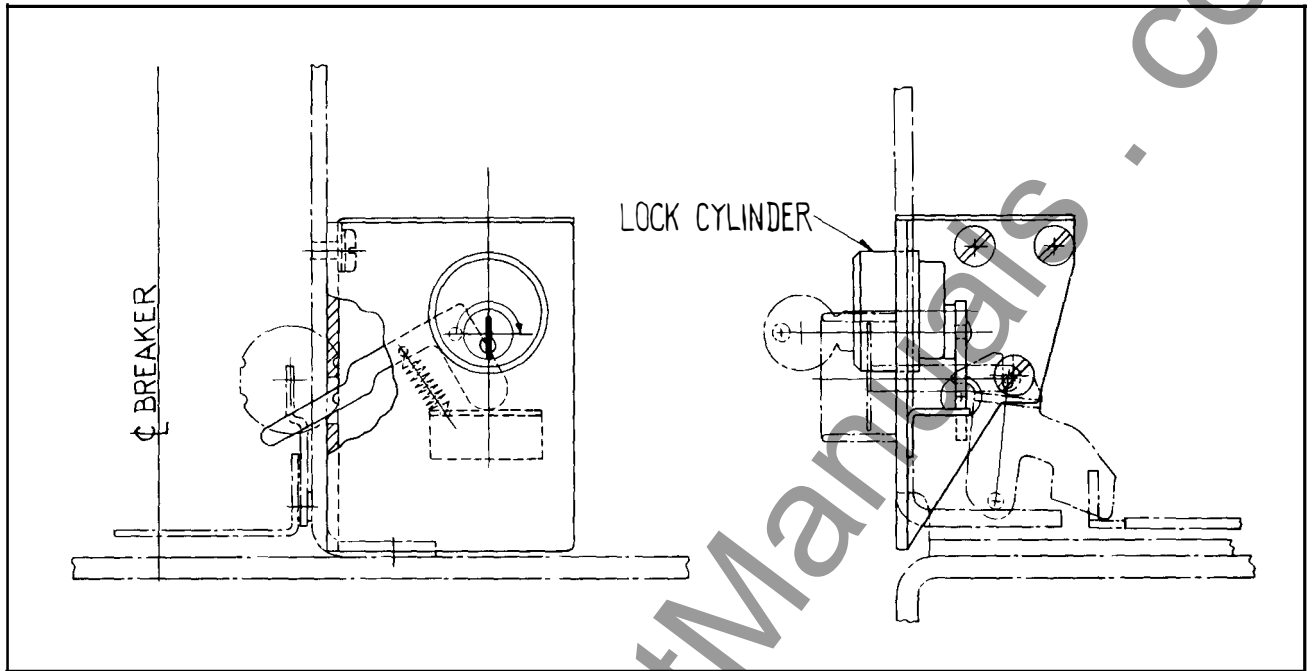

Fig. 24 - Key Lock or Key Interlock Attachment - Construction Details

that the common voltages for 60 cycles can be connected to the appropriate terminal on the unit. A terminal block is mounted on the rectifier unit to facilitate all wiring.

NOTE: For A-C operated breakers with the closing rectifier mounted on the right side of the closing solenoid mechanism, the rectifier unit required for A-C undervoltage and/or electric lockout attachments must be mounted external to the breaker.

Inspection

There are no moving parts. Make certain a-c incoming leads are connected to proper terminals.

Maintenance

Check for loose connections.

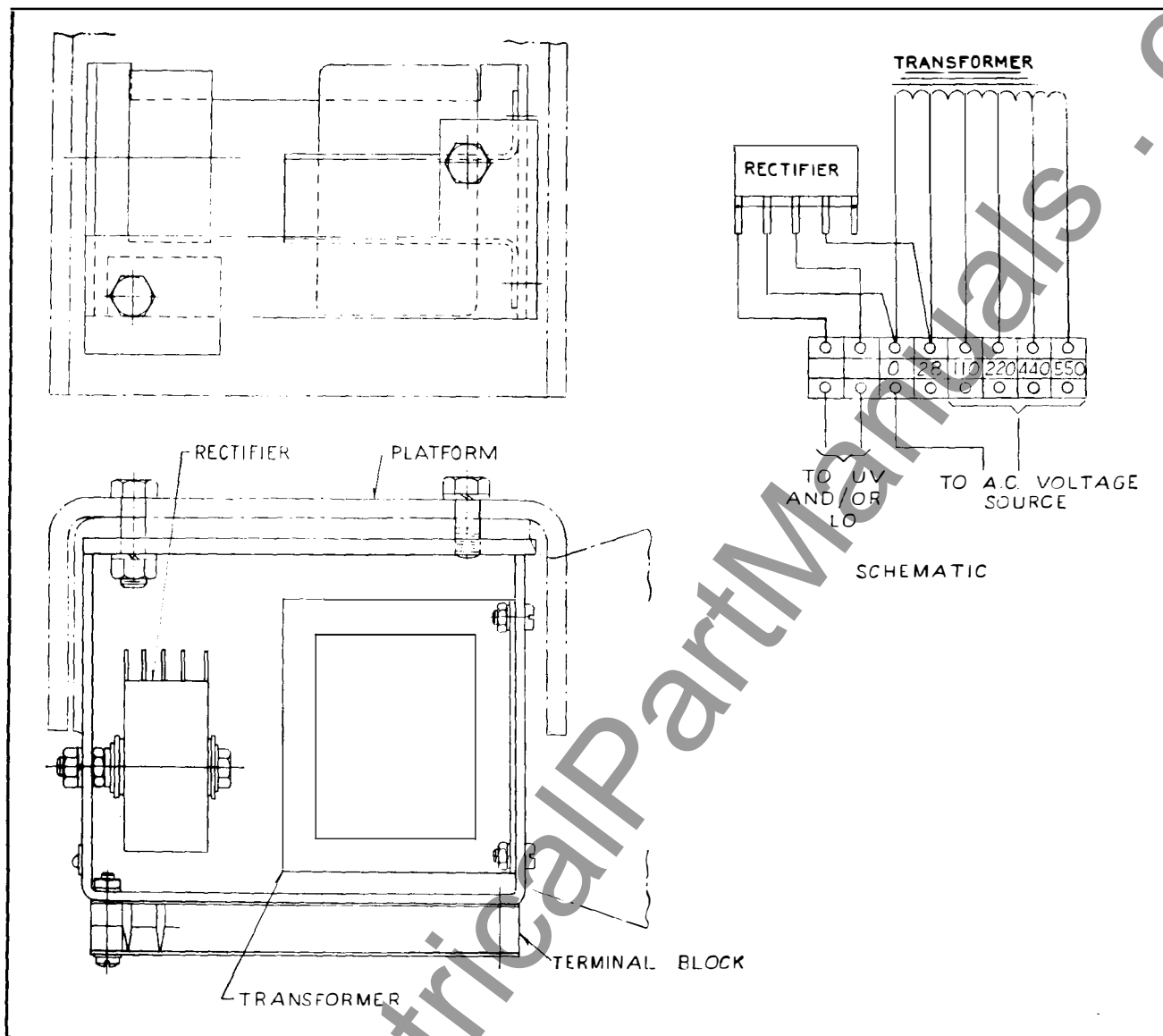

Fig. 25 - Rectifier Unit for A-C Undervoltage and A-C Electric Lockout Attachments

Recommended Spare Parts for DB50 Air Breaker

NAME OF PART (ALWAYS GIVE BREAKER S.O. REFERENCE)	STYLE NUMBER OR REFERENCE	NUMBER PER BREAKER OR DEVICE	NUMBER RECOMMENDED		
			FOR BREAKERS		
			1	2 TO 5	6 UP
AUXILIARY SWITCH	FIG. 21				
4 POLE SWITCH UNIT	NO. 187	1 OR 2	-	1	2
FRONT COVER	NO. 186	1	-	-	1
CONTACT FINGER 184	1397624	8	-	4	8
CONTACT ROTOR 185	1397641	4	-	4	8
CONTROL RELAY	FIG. 15				
OPERATING COIL	NO. 166	1	-	1	2
BLOWOUT COIL & CIRCUIT-DC	NO. 161	1	-	1	2
MOVING CONTACT-LEFT POLE	NO. 153	1	-	2	4
MOVING CONTACT-RIGHT POLE	NO. 163	1	-	1	2
STATIONARY CONTACT-LEFT POLE	NO. 160	1	-	2	4
STATIONARY CONTACT-RIGHT POLE	NO. 165	1	-	1	2
COVER	NO. 159	1	-	-	1
POLE UNIT	FIG. 3				
STATIONARY ARCING CONTACT	NO. 314	3	3	6	12
STATIONARY MAIN CONTACT	NO. 313	3	-	1	3
MOVING ARCING CONTACT	NO. 301	3	3	6	12
MOVING MAIN CONTACT	NO. 312	6	-	2	4
AUXILIARY MAIN CONTACT	NO. 310	12	-	2	4
ELECTRIC OPERATION					
CLOSING COIL	FIG. 3 NO. 304	1	-	1	2
SHUNT TRIPPING COIL	FIG. 16 NO. 320	1	-	1	2
OVERCURRENT DEVICE COMPLETE	FIG. 6	3	-	1	2
RETAINING RINGS ASSORTMENT	497A346G03	1	1	2	3

www.ElectricalPartManuals.com