

*Phil*  
*11 pages*

# Westinghouse

## Type CHM Air Circuit-Breaker

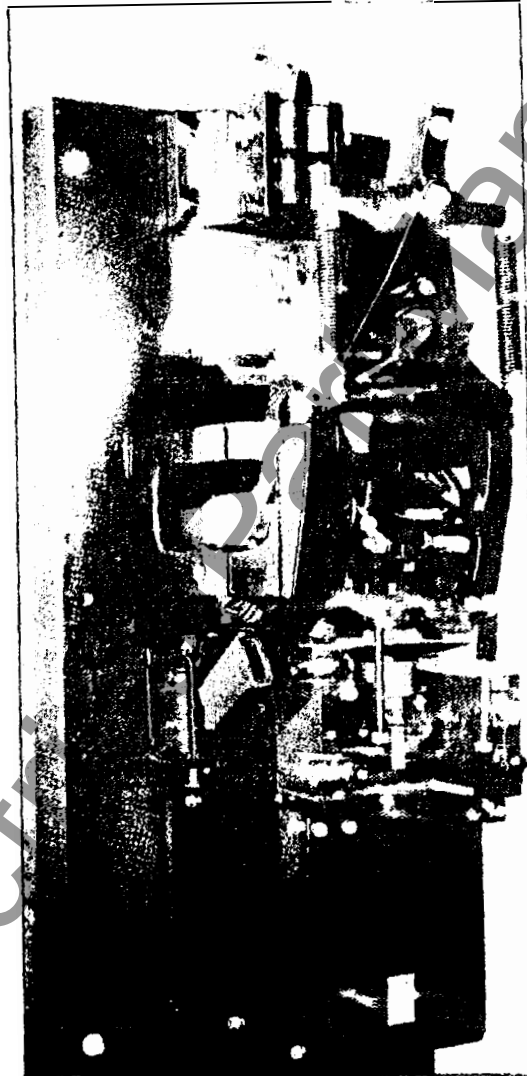

FIG. 1—PANEL MOUNTED BREAKER

Westinghouse Electric Corporation  
East Pittsburgh, Pa.

Printed in U.S.A. (Reprinted 5-52)

IB 5772-A  
Filing No. 35-000

WWW.ElectricalManuals.com

## TYPE CH CIRCUIT BREAKER



TYPE CH

It would be difficult to over-emphasize the importance of adequate care of all protective devices. To assure proper functioning, they should be the subject of periodic, systematic and intelligent inspection. Even the smallest details of required maintenance should not be neglected if costly failures of equipment and service are to be avoided. The frequency and character of inspection will for the most part be a matter of experience. In general, light monthly inspection with a thorough inspection semi-annually, should be a minimum.

### KEEP CIRCUIT-BREAKERS CLEAN

Excessive deposits of dust and dirt in the operating parts of a circuit-breaker invariably cause binding of shafts, rollers and the operating levers. Care should be taken therefore to see that accumulation of dirt is prevented and this is particularly true in new installations where the circuit-breakers have been installed before the building construction work has been completed. In the latter case the breakers should be completely covered by a tarpaulin.

### MAINTENANCE

Instruction Book 5241 tells in general terms how to take care of any carbon circuit breaker but does not take care of the breakers with silver plated contacts or some peculiar feature that may require mention.

The contacts of this breaker are silver plated. This plating is only a few thousandths of an inch thick so no scouring or filing should be done except to remove high spots caused by burning. Silver plated contacts soon turn dark from oxidizing or sulphiding. Since these darkened contacts still have low voltage resistance, they should be cleaned only by a cloth moistened with an organic solvent, such as alcohol or naphtha.

Certain adjustments are made in the Type CH breaker when it is assembled. First the turn

buckle connecting the shunt trip or holding magnet to the trip free lever is adjusted so that in the open position the pin connecting the eye bolt to the front end of the reset lever is in the same straight line as the fulcrum pin in the main hand operating lever. Second the next adjustment is in locating the moving closing core so that it hits the stationary core after the toggle snaps over center about 1/64 before the toggle link hits its stop.

The main brush and contact surfaces of the studs should make good contact with each other. If contact pressure is insufficient loosen the four screws that go through the brush arm and thread into the brush back, and tighten up on the large screw located in the midst of the four first mentioned screws. Care must be taken not to force the brush too far as an over deflection of the brush will cause the laminations to first close up and then force the toes of the brush away from the studs.

Most of the bearings on the "CH" breaker are provided with oil holes. A drop or two of oil on the bearing pins will prevent undue friction and permit the closing and tripping devices to operate without danger of sticking. After oiling, all visible oil should be thoroughly removed to prevent the collection of dust.

The carbons are first copper plated then soldered to the sheath. If several minutes elapse between the opening of one overload until the opening of the next one the heat in the carbon due to the arc will nearly all have disappeared but if the overloads appear at very short intervals and are a large number, the carbon will get hot enough to melt the solder. If the solder has flown out between the carbon and the sheath the fact will be apparent because it will be spattered in small particles over the lower parts of the breaker. New carbon and sheaths should then be installed.

After the breaker has opened many times on overloads the secondary contacts will be badly burned and roughened. The roughness should be

removed with a file occasionally in order to prevent the arcing that occurs on the secondary contact from spreading to the main brush contacts.

Both secondary and carbon contacts should be renewed when they have become so badly worn or burned that they cannot be refitted to make good contact.

## TRIPPING DEVICES AND ATTACHMENTS

### Instantaneous Trip

The instantaneous trip device is used to trip a circuit breaker whenever the current in the circuit which the breaker protects exceeds a certain predetermined safe value. It consists of a coil in series with the line, the ampere turns of which act on a magnetic circuit consisting of a stationary portion and a moving iron core. When the ampere turns of the series coil are great enough or in other words when the current through the series coil reaches a certain value the moving core is attracted to the stationary portion and this movement serves to trip the breaker. The instantaneous trip device will trip the circuit breaker on any overload above its setting.

Of the total travel of the moving core, the part used to move the toggle lever should be just long enough that breaker trips just before moving core strikes magnet pole face. This unit was calibrated from 2000 to 9000 amperes. To change calibration point loosen thumb nut and turn thumb screw to the desired calibration point, then lock with thumb nut.

Do not set calibration below minimum calibration point.

Care should be taken not to interchange overload details.

### Shunt Trip

The shunt trip magnet is of the solenoid type, the movable core of which is pulled towards

the stationary core when the shunt coil is energized. Movement of this core trips the circuit breaker and the coil is immediately out of the circuit by an auxiliary contact on the circuit breaker when the latter opens. This is necessary since the shunt trip coil is short time rated and would soon burn out if the voltage were applied for any length of time.

Of the total travel of the moving core, that part used to move the toggle lever should be only long enough that the breaker trips just before the moving and stationary cores come together.

A brass washer is placed between the moving and stationary cores to prevent freezing. This permits the moving core to return to its normal position after the coil is de-energized. If this brass washer is omitted the residual magnetism may hold the moving core against the stationary core, even after the coil is de-energized, and it will then be impossible to trip the breaker open by means of the shunt trip until the residual magnetism disappears and the core drops back of its own accord.

To install a new shunt trip coil remove shunt trip magnet from the breaker, then remove stirrup and the stationary core and the core guide. The coil can then be taken out and replaced by a new

To install a new closing coil disconnect the coil leads then remove the bolts that fasten the bottom cover to the magnet frame. The coil can then be removed and another one installed.

### Reset Auxiliary Switches

Auxiliary switches are used for signal lamp circuits, shunt trip cutouts and electrical interlocking. The switch is connected to an operating link by means of a lever on the end of a rotor. The operating link should be adjusted so that the make and break contacts make good contact with the stationary contacts. These switches should be inspected occasionally to see that the contact springs are in good working condition.

renewal parts  
illustration

35-000  
section CHM

air circuit breaker  
type CHM  
indoor service-electrically operated  
*200-10,000 amperes -750 volt D-C  
single pole - single throw*



switchgear apparatus

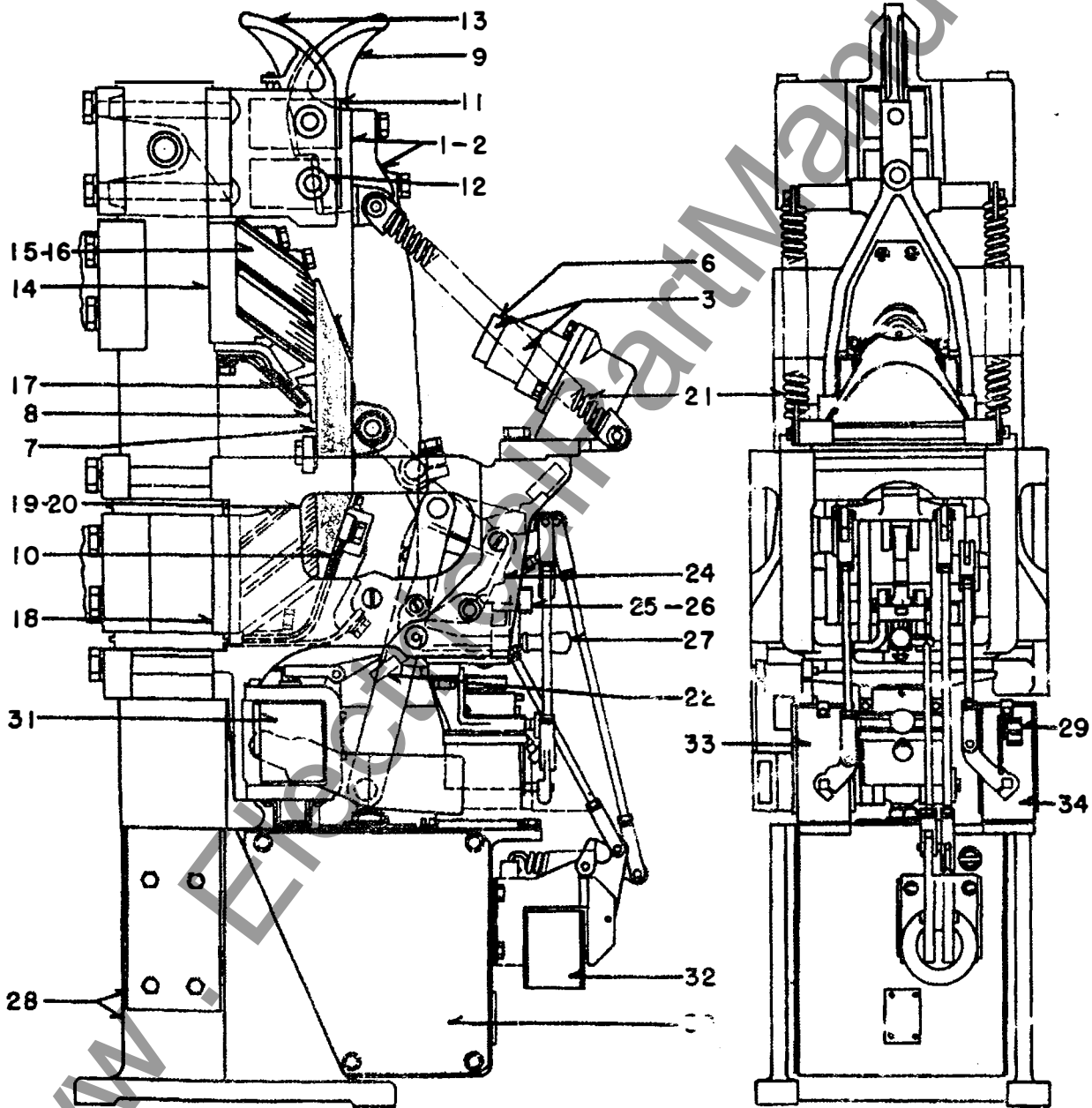



2 - type CHM air circuit breakers  
 pedestal mounted  
 electrically operated - automatic trip  
 8000 ampere - ~~750~~ volt d-c - single pole  
 s.o. 33-V-1418

renewal  
 parts data

general order  
 CG-88500-Y

For typical illustration, see r.p.d. 35-000-P, section: CHM  
 the following parts are most subject to wear in ordinary operation:

ref. no.	name of part	identification number	number per unit
.	circuit breaker	s.o.33Y1418	1
3	bumper	85B0331G01	1
4*	spring - inner	305P019H01	1
5*	spring - outer	305P018H01	1
∅	spring retainer	1037 704	1
6	rubber bumper	1074 112	1
*	piston	1092 168	1
*	piston ring	1035 207	2
*	headless set screw	160 481	1
∅	housing	1037 703	1
*	rivet - (through bumper) 2-5/8" x 1/8" steel bar		1
1	moving contact assembly	97A0463G03	1
2	contact arm	90AC215G02	1
2	arm	1245 741	1
*	bumper plate	1041 672	1
*	spring	1035 378	2
*	spring retaining clamp	1035 379	2
*	Micarta tube	1041 779	1
*	bearing insulating bushing	1041 477	2
*	bearing steel bushing	1041 478	2
9	arcing contact	1035 460	1
*	contact arm hinge pin	1041 480	1
*	spring pin (through Micarta tube)	1041 479	1
*	hinge bolt (switch operating rod)	1016 956	1
7	main contact	29B8807G03	1
8	secondary arcing contact	1035 476	1
10	main shunt - left hand	1070 800	1
10	main shunt - right hand	1070 801	1
*	shunt insulation - flat	1245 737	1
*	shunt insulation - bent	1248 478	1
*	main contact bearing	1130 372	1
*	insulation under bearing	1245 789	1
*	main contact hinge pin	1091 894	1
*	hinge pin copper alloy bushing	1091 893	2
*	hinge pin insulating bushing	1091 892	2
*	hinge pin key	1091 895	2
*	bearing bolt insulating tube - long	1016 921	2

(continued)

\* not illustrated

) not indicated on illustration

note: Parts indented are included in the part under which they are indented. Order part by name and identification number - give complete nameplate reading.



2 - type CHM air circuit breakers

s.o. 33-Y-1418

(continued)

renewal  
parts datageneral order  
CG-88500-YFor typical illustration, see r.p.d. 35-000-P, section: CHM  
the following parts are most subject to wear in ordinary operation:

ref. NO.	name of part	identification number	number per unit
*	bearing bolt insulating tube - short	1016 920	2
*	bearing bolt insulating washer	1016 924	4
*	bearing bolt spacer	1016 925	4
11	stationary arcing contact	1074 113	2
12	stationary arcing contact spring	946 830	4
13	arcing horn	1043 629	1
14	stud - upper	01A6090G02	1
15-16	contact brush - inner	1014 272	1
15-16	contact brush - outer	1014 274	1
17	secondary arcing contact	1014 278	2
*	secondary contact insulation	1035 475	1
*	secondary contact bracket	1035 477	1
18	stud - lower	01A6091G01	1
19-20	contact brush - inner	1014 272	1
19-20	contact brush - outer	1014 274	1
	acceleratin spring	1074 114	2
	accelerating spring end	1035 370	4
*	spring retaining pin - lower	1288 694	1
22	tripping lever	1534 461	1
22	lever	1534 458	1
*	copper alloy bolt (engages overload trip)	28A1384H06	1
*	copper alloy bolt (engages shunt trip)	28A1384H07	1
*	copper alloy lock nut	28A1384H08	2
27	tripping handle	677 290	1
*	hinge pin	711 439	1
24	latch	1534 457	1
25	latch spring	1289 781	1
*	latch hinge pin	806 110	1
*	pedestal	90A0676001	1

(continued)

\* not illustrated

**note:** Parts indented are included in the part under which they are indented. Order part by name and identification number — give complete nameplate reading.



2 - type CHM air circuit breakers

s.o. 33-Y-1418

(continued)

renewal parts data

general order  
CG-88500-Y

For typical illustration, see r.p.d. 35-000-P, section: CHM  
the following parts are most subject to wear in ordinary operation:

ref. no.	name of part	identification number	number per unit
Ø	closing lever	1070 852	1
Ø	closing lever hinge pin (in moving core)	898 188	1
*	closing lever hinge pin (in frame)	885 726	1
*	closing lever spring - outer	1289 782	2
*	closing lever spring - inner	1289 783	2
*	stationary spring retainer - upper	1084 335	1
*	moving spring retainer - lower	1084 336	1
*	pin - engaging closing lever and spring retainer	1084 337	2
*	insulation - over springs	1035 478	1
31	shunt trip attachment	85B0490G01	1
*	moving core	405 956	1
*	stationary core	452 337	1
*	core seat	405 891	1
Ø	trip lever	70B0551H01	1
	trip lever hinge pin	452 329	1
	coil - 250 volt d-c	476 368	1
*	coil spacing washer	450 531	4
32	not used		-
33	type W auxiliary switch - 2 stage (page 405)	1019 406	1
34	type W auxiliary switch - 9 stage (page 405)	1019 407	1
*	lever - 2 stage switch	1035 452	1
*	lever - 9 stage switch	1035 453	1
*	operating rod - 2 stage switch	41C0431G02	1
*	operating rod - 9 stage switch	41C0431G01	1
*	overload trip attachment	s.o. 33Y1418	1
*	armature complete	14B7119G02	1
*	thumb screw	1016 955	1
*	undervoltage trip attachment	69B0228G01	1
*	spring	1035 229	1
*	undervoltage trip coil - 250 volt d-c	1019 648	1
*	hand closing lever	1035 467	1 ++

\* not illustrated

++ total furnished

reference:-

instruction book 5772

note: Parts indented are included in the part under which they are indented. Order part by name and identification number - give complete nameplate reading.

# Westinghouse Carbon Circuit-Breaker Maintenance

## General

The maintenance of carbon-break circuit-breakers can broadly be divided into two main divisions; viz., keeping the breaker in condition to open the circuit without material damage to itself under the predetermined conditions of opening, and keeping it in condition to carry its rated load without rising in temperature more than the standard allowable rise.

In all modern carbon circuit-breakers there is a main brush or other form of moving contact, and one or more other contacts whose function is to carry the current for a very short time after the main moving contact separates from the main stationary contact. An arc therefore will not be drawn between the main brush and the stationary contact, and the brush will not be damaged and will be able to carry the rated load successfully when the circuit-breaker is again closed. Some breakers have, in addition to the main contacts, secondary contacts, tertiary contacts, and final carbon contacts, between which the arc is broken.

The diagram (Fig. 2) shows the shape and relative position of each of the contacts for a breaker of large ampere capacity in the two important stages of breaking the circuit as follows:

1. Contacts outlined by full lines show main brush opened, secondary contact on point of opening and carbon contacts not changed from closed position.
2. Contacts shown by dotted lines show secondary contacts open and the carbon tips about to finally break the circuit.



FIG. 1—12,000-AMPERE, THREE-POLE, TYPE CA CARBON CIRCUIT-BREAKER ELECTRICALLY-OPERATED

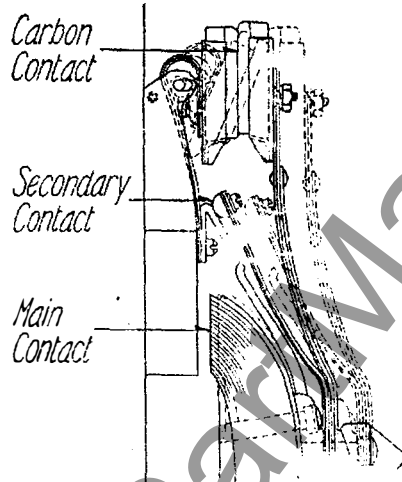

FIG. 2—TYPE CL CARBON CIRCUIT-BREAKER CONTACTS

Full lines show the main contacts open, secondary contacts about to open and carbons still closed.

Dotted lines show both the main and secondary contacts open and the carbons about to open.

**Arcing Contacts**—These contacts, as they open successively, increase the resistance in the circuit and to a certain extent limit the value of the current at the time the carbon contacts open. However, if the resistance in the contacts is too large when the brush opens, the brush will draw an arc and the resulting scars will lessen the ability of the brush to carry full load thereafter.

When breaking any considerable current there is always an arc between the carbons, and when the carbons are so roughened and burned that the contact resistance is very high, there will be an arc between the secondary contacts when they open.

When the secondary contacts become sufficiently roughened by the arc, the brush and main stationary contacts will begin to arc when the breaker opens. It is therefore necessary, in order to keep the breaker in condition to carry its rated load without getting too hot, to also keep the parts of the breaker that are used to open the circuit in good condition.

Whenever the secondary contacts become rough the breaker should be opened at the first opportunity and the contacts filed until they make a good contact. When the carbons are burned so that the contact area is materially lessened they should be dressed to make as good contact as is possible. If they are broken or very badly burned so that

they cannot be put in good condition, new carbons should be installed. Likewise new secondary contacts should be put on when they are worn or burned out.

## Overheating

Properly designed and installed breakers will carry their rated amperes without overheating as long as the contact resistance between the main moving (brush) and stationary contacts remain normal, unless some other electrical connection is defective. One cause of overheating of circuit-breakers is the use of insufficient lead capacity or the use of a hot ammeter shunt too near the breaker. Another cause of overheating is defective contact between parts of the conductivity material, other than the main (brush) contact, e.g., nuts clamping terminals or bus-bars to the studs may have poor contact with the studs or with the terminals or bus-bars. This poor contact may be due to insufficient contact pressure, insufficient contact area, or oxidized or corroded contact surfaces.

**Insufficient Contact Pressure**—If the contact pressure is not enough, it is obvious that tightening the nuts is the remedy.

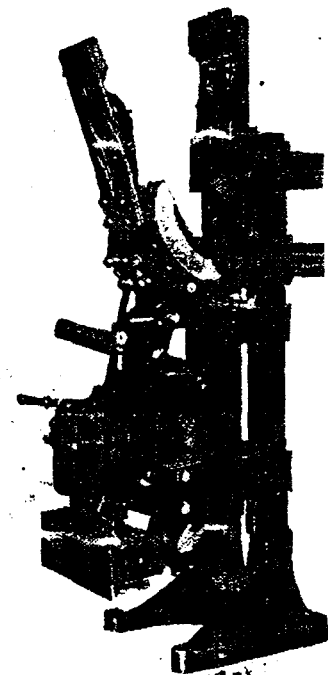

FIG. 3—4000-AMPERE, TYPE CH CARBON CIRCUIT-BREAKER, PEDIESTAL MOUNTING WITH SHUNT-TRIP COIL

[www.ElectricalPartManuals.com](http://www.ElectricalPartManuals.com)

*Westinghouse Carbon Circuit-Breaker Maintenance*

Insufficient contact area may be due to untrue surfaces on the nuts, studs or bus-bars or terminals, or too small or too few nuts. Contact surfaces that were true when made may become untrue by being battered, raising high spots on the surface. When the amount of battering is small and the surface is plain, the best way is to carefully file off the high spots. If the amount of battering is large, it is best to machine the surface. Where it is the threads on the studs that are battered, they can usually be partially restored by filing away the high spots with a small three cornered file.

**Oxidation and Corrosion**—Oxidized and corroded surfaces of threads on studs and nuts may be cleaned by rubbing with a brush, a piece of cloth, or waste dipped in a mixture of water and powdered pumice stone, or some other finely ground scouring material.

**Defective Joints**—Overheating may be due to a defective soldered joint. It often happens that a soldered joint that was good when made has been partially broken by too great a mechanical load on the joint. The heat then developed has melted the solder causing it to run out of the joint. A soldered joint may be spoiled similarly by an overload, causing the solder to melt and part of it to run out of the joint, rendering it incapable of carrying its rated load thereafter.

**Poor Main Contact Pressure**

The most frequent cause of overheating of carbon circuit-breakers is bad contact between the main moving and

stationary contacts. Like poor contact on contact nuts, the bad contact on the main (brush) contacts may be due to any or all of the three causes, viz. insufficient pressure, insufficient contact

and oxidized, corroded, or dirty contact surfaces. Any carbon circuit-breaker if allowed to stand will heat up, due to oxidation. It should be opened occasionally to rub up its contact surfaces, and if this cannot be done, it should be applied very conservatively. If the brush has insufficient contact pressure, adjustments should be made to secure the required pressure. If the whole or nearly the whole contact area of the brush does not touch the opposing contact, it will be necessary to refit the brush with a file or otherwise, so that it makes contact as intended.

A good way to determine whether the brush and opposed contacts are touching each other is to mark the brush with a soft pencil and then close the breaker with a piece of thin paper between the main contacts. If the whole area is making contact every lamination of the brush will make an impression on the paper. If there are spots where the brush does not touch the stationary contact, blank spaces will show on the paper.

If the contact surfaces are oxidized or corroded they should be cleaned with fine sand paper. A good way to hold the sand paper is to tack it to pieces of hard wood as shown in the upper sketch of Fig. 7.

If contact surfaces are dirty they can be readily cleaned by the use of alcohol, gasoline, ammonia, water and soap, or other solvents.

It is important to note that breakers with semi-elliptic brushes usually give more trouble with the contact between



FIG. 4—4000-AMPERE TYPE CH CARBON CIRCUIT-BREAKER, PANEL MOUNTING WITH HOLDING COIL

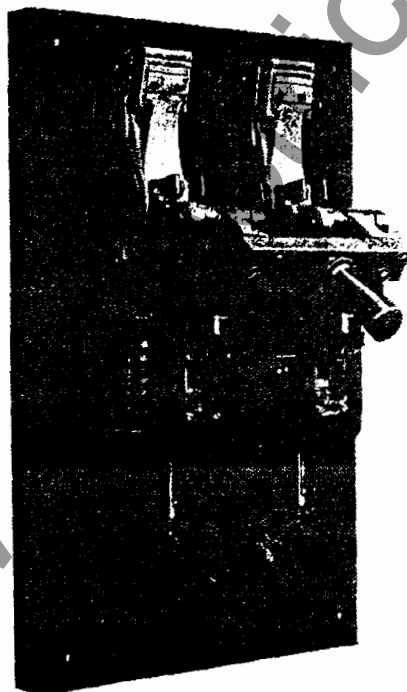

FIG. 5—300 AND 400-AMPERE, TWO-POLE, TYPE CL CARBON CIRCUIT-BREAKER WITH SINGLE CLOSING HANDLE, AND TWO PLAIN OVERLOAD COILS

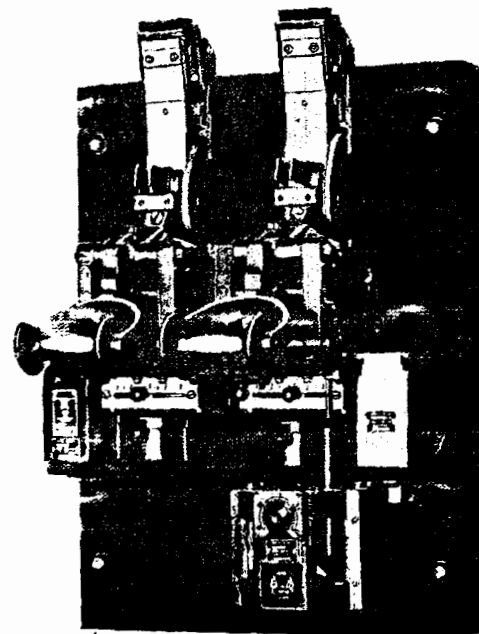

FIG. 6—1200-AMPERE, TWO-POLE, TYPE CL CARBON CIRCUIT-BREAKER, WITH TWO CLOSING HANDLES, DASH-POT TIME-LIMIT OVERLOAD, UNDERVOLTAGE RELEASE, REVERSE CURRENT AND SHORT-TRIP ATTACHMENTS.

Westinghouse Carbon Circuit-Breaker Maintenance

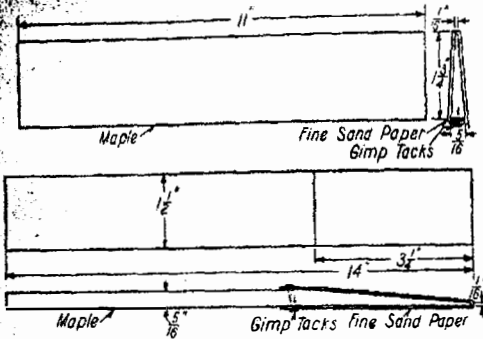

FIG. 7—SAND PAPER HOLDER

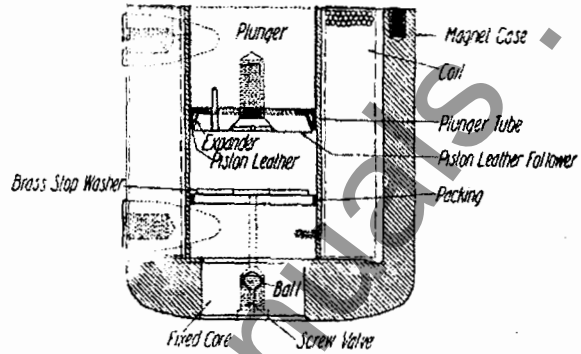

FIG. 8—CLOSING MAGNET WITH DASH-POT FOR CUSHIONING THE PLUNGER TO PREVENT EXCESSIVE SLAMMING

the brush and bottom stud than they do between the brush and top stud. This is due to the fact that in most cases the bottom end of the brush and the contact surface of the bottom stud are not as easily accessible as the top stud and the top end of the brush, resulting in more or less neglect of the bottom contact. The lower sand paper holder in Fig. 7 is made especially for use on the lower stud and lower end of the brush where it can be reached only from above.

Transferring Circuit-Breakers

A prolific source of trouble with carbon circuit-breakers is the transfer of the breaker from the base on which it was mounted in the factory to a panel of a switchboard. Most carbon circuit-breakers depend on the base to hold some of the parts in proper relation to each other. Type CL carbon circuit-breakers, however, are provided with one piece frames and may, therefore, be moved from one panel to another with much less difficulty than breakers with two piece frames which are held in alignment by the panel. It is, of course, necessary to align one pole with respect to another in order to obtain proper operation of common trip and common closing bars. Each pole unit, however, with its one piece frame retains shaft alignments independently of the panel.

When mounting multipolar circuit-breakers it is very important that the pole units be lined up properly with respect to each other, so that the common trip and common closing bars operate freely. To check this, take a shaft as long as the total width of the breaker (not pole unit) and of the same diameter as the handle lever fulcrum shaft and push it through the holes in the frames from which the handle lever fulcrum pins have been removed. This should be done before tightening the frame mounting bolts. See that the shaft turns freely and then tighten the frame mounting bolts. The shaft may then be removed and the breaker assembled with assurance that the pole units will be in proper alignment.

When clamping the upper stud in place, be sure to see that it is in proper relation to the moving parts such as carbon arm, brush and secondary contacts.

Attachments

Circuit-breakers are usually provided with an overload trip, an undervoltage trip, a shunt trip, an undervoltage trip, an underload trip, a reverse-current trip, or an inverse-time-limit overload trip. Some circuit-breakers are also provided with a closing coil.

Undervoltage trip coils and the shunt coils for the reverse current trip are subjected to their rated voltage continuously. When this voltage is large the coils are sometimes protected by an external resistance. The use of external resistance permits winding the coil with larger wire and results in the coil being more rugged and durable.

Undervoltage coils and reverse-current shunt coils (with their resistances when used) are designed to withstand a definite line voltage. If they are subjected to a voltage much in excess of the rated voltage they will finally attain a temperature

which will destroy the insulation of the coil.

Alternating-current undervoltage coils usually are connected so that voltage is removed from the coil when the circuit-breaker opens. Where alternating-current undervoltage coils remain in circuit after the breaker opens, a means of retrieving the armature to its closed position by the opening of the breaker is provided. This prevents undue current flowing through the coil due to open magnetic circuit and consequent overheating. Careful inspection should be made to see that complete retrieving is obtained.

Shunt trip coils and closing coils on latched breakers are subjected to the voltage of the control circuit only during the time of opening and closing of the breaker, so they do not have much tendency to get hot unless the breaker is closed and tripped a good many times in a short period of time. Voltage must not be kept on such coils continuously. Closing coils on breakers without latches are usually protected against overheating by a resistance which is cut in at the end of the closing motion of the breaker.

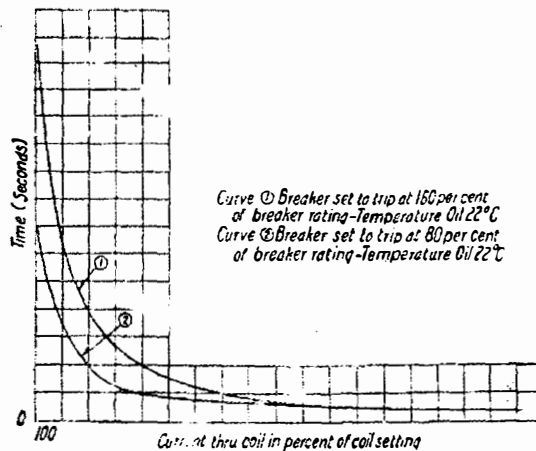

FIG. 9—CHARACTERISTIC CURVES OF INVERSE-TIME-LIMIT DEVICE

### Westinghouse Carbon Circuit-Breaker Maintenance

Closing coils are usually designed to close the circuit-breakers between certain maximum and minimum voltages. These limits are usually as wide apart as it is reliable and safe to operate. If the voltage is lower than the minimum, the circuit-breaker is liable not to close, and if it is above the maximum it is liable to cause damage to the breaker on account of the excessive speed of closing. It is especially liable to break the carbons.

When figuring the actual control voltage that will exist at a breaker, account must be taken of the drop in the control wires. The range of voltage marked on the nameplate means the voltage at the coil terminals, therefore, the control bus voltage must be selected with this in view.

In order to stop the breaker at the end of the opening stroke, a friction spring device and buffer are sometimes provided. To be effective the friction buffer should be so adjusted as to give sufficient pressure between the surfaces to retard the breaker so that it will not bound back or hit too hard at the end of the opening movement. On electrically-operated breakers care must be taken not to have too much friction or the breaker will fail to close on the minimum operating voltage.

On some heavy electrically-operated breakers, dash-pots are used to lessen the shock due to closing on the higher part of the control range. Such dash-pots usually have adjustable valves. The valve should be set to give best operation at the control voltage used on each particular breaker. Regular inspection should be made and the piston leather kept oiled with neatfoot oil and clean and the valve passages free from dirt. Before being put in operation, this whole piston and valve mechanism should be inspected to see that no dirt or refuse from packing has accumulated and that all parts are free from rust, etc.

"Inverse-time-limit" tripping is usually accomplished by attaching some kind

of dash-pot to the moving element of the tripping magnet. Two kinds of dash-pots have been used for this purpose. In the piston dash-pot, a piston is arranged so as to move slowly for some distance against the resistance of the working fluid, then the fluid ceases to offer resistance and the remainder of the movement is very rapid, tripping the breaker at or near the end of the movement. The action of such a dash-pot usually is varied by the adjustment of a pin valve. The sucker disc dash-pot consists of two surfaces in intimate contact, the contact surfaces being immersed in oil or other viscous fluid. One of these surfaces is

working order, it is necessary that the oil be kept clean. A single particle of dirt between the two surfaces of the sucker dash-pot will sometimes reduce the time to zero. The engaging surfaces must be protected so that no high spots appear on either surface. If imperfections appear in the surface due to bruising or other cause, all high spots should be removed with a scraper. Experience has shown that satisfactory operation can be had with the oil  $\frac{1}{4}$  inch deep above the stationary surface.

With defective adjustments, it may happen that when the moving element of the overload, reverse-current, or shunt-trip magnets moves to trip the breaker, the breaker fails to open. One reason for this happening is that the moving element strikes the latch too early in its movement; that is before it has accumulated enough energy to open the latch. In cases like this, adjustments should be made so that the latch is freed just before the moving magnet element strikes the stationary element.

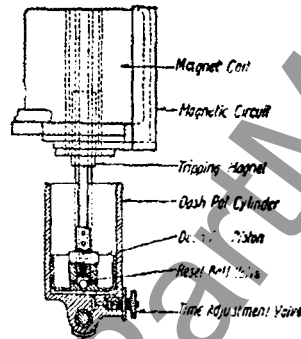

FIG. 10--PISTON DASH-POT

movable and is attached to the moving element of the trip magnet. Unless the pull of the trip magnet is as great or greater than the product of the atmospheric pressure in pounds per square inch, and the area of contact in square inches between the contact surfaces, the moving member will be held without appreciable movement until the oil or other fluid can flow between the surfaces. The time required to separate the surfaces varies approximately inversely as the pull, and directly as the viscosity of the oil. If the time limit is too short, it can be lengthened by using a more viscous oil. To keep the inverse-time-limit in good

### Oiling

Every circuit-breaker has a little oil put on each pin or shaft when it is being assembled. In time this oil works out. Before the bearing becomes dry one or more drops of oil should be applied and worked into the bearings. All excess oil should be thoroughly wiped off so as to prevent the accumulation of dust or dirt. If this oiling is done regularly there will be no danger of the breaker failing to open when it is unlatched by the trip magnet or by hand.

### Renewal Parts

When ordering renewal parts, specify the name of the part wanted and give the number of the circuit-breaker. The style or stock order number will be found stamped on the name plate. Renewal Parts Catalogue will be supplied upon receipt of request.

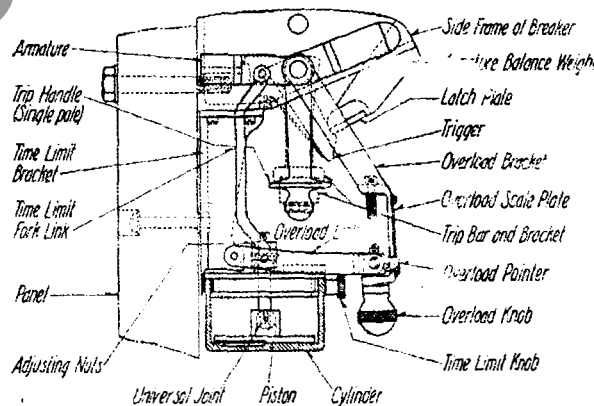

FIG. 11--SUCKER DASH-POT

# Westinghouse

## Type CHM Air Circuit-Breaker

### **MB Industrial Equipment Inc.**

P.O. Box 14 152 West 4th Avenue

Tarentum, PA 15084

Phone: (724) 226-8336 Fax: (724) 226-9760

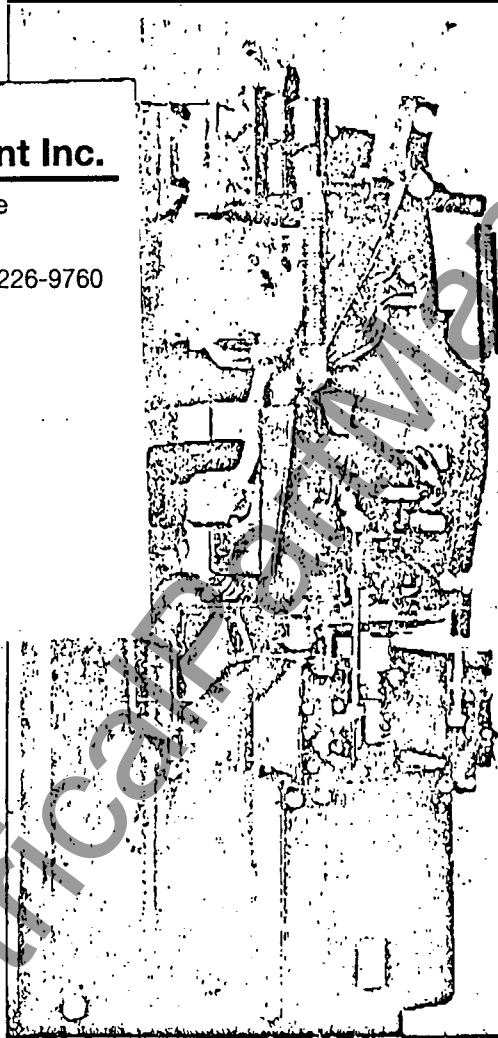

FIG. 1—PANEL MOUNTED BREAKER

Westinghouse Electric Corporation  
East Pittsburgh, Pa.

Printed in U.S.A. (Reprinted 8-82)

1B 5772-A  
Filing No. 35-006

Type CHM Air Circuit-Breaker

INDEX

INSTRUCTIONS FOR OPERATION

Rating . . . . .	4
Application . . . . .	4
Mounting . . . . .	4
General. . . . .	4
Circuit Interrupting Details. . . . .	4
Bumper . . . . .	5
Electric Operating Mechanism. . . . .	5
Overload Trip. . . . .	6
Inverse Time Limit Attachment . . . . .	6
Instantaneous Trip . . . . .	6
Bus Connections . . . . .	6
Inspection and Maintenance . . . . .	6
Attachments . . . . .	7
Shunt Trip Attachment . . . . .	7
Undervoltage Release Attachment. . . . .	7
Operation Counter . . . . .	8
Renewal Parts Data . . . . .	9
Table . . . . .	10
Ordering Instructions . . . . .	10

WWW.ElectricalPartManuals.com

[www.ElectricalPartManuals.com](http://www.ElectricalPartManuals.com)

# Important

## Type CHM Air Circuit-Breaker

### Keep Main Copper Contacts Clean

In contrast to copper oxide, silver oxide or sulphide is a comparatively good conductor so that circuit-breakers having silver plated main contacts do not require the removal of oxide. As a matter of fact sandpaper should never be applied to silver plated contacts since the useful silver plating would thereby be removed.

### Maintain Proper Main Contact Pressure

While it is true that after the main brush contacts have been properly adjusted they will remain so indefinitely, occasional inspections should be made to see that all adjusting screws are tight and if any of these screws are found loose to see that the brush adjustment has not shifted.

### Lubrication

Lubrications of the various parts of the mechanism as applied at the factory should be sufficient for many months of service. Experience indicates that lubrication is generally applied too freely rather than insufficiently. If a bearing seems to require lubrication, apply only sufficient oil to provide a thin film on the working parts. Excessive use of oil promotes the accumulation of dirt, and oil is very detrimental to any contact surface to which it may spread or upon which it may be thrown. Alemite fittings are provided for the lubrication of the main toggle pin bearings. It is very important that these bearings have lubrication at all times.

WWW

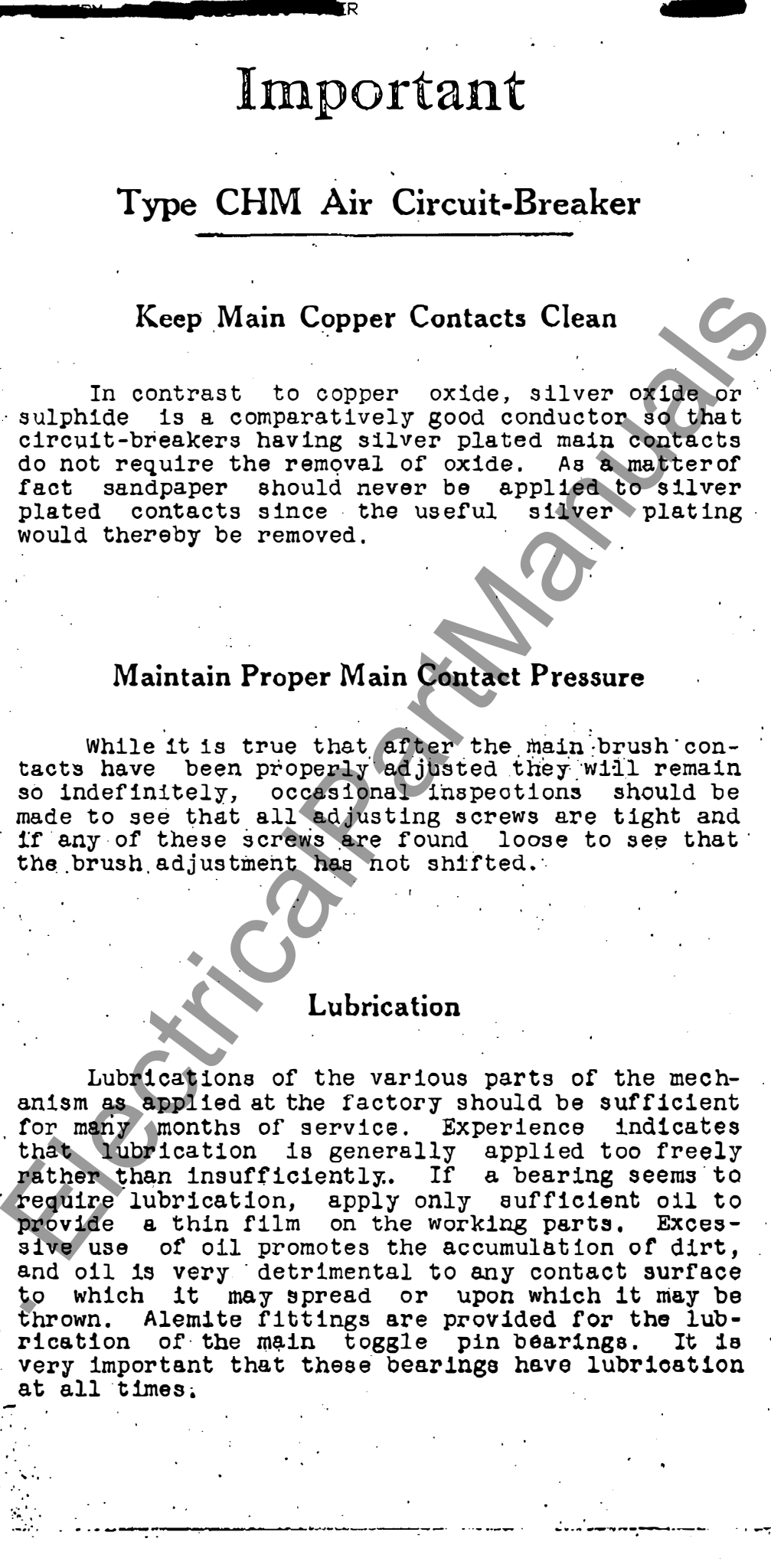

## Type CHM Air Circuit-Breaker

## Instructions for Operation

**RATING:** 2000 to 10,000 amperes, 750 volts  
D-C Single Pole. Panel or Pedestal  
Mounting.

**APPLICATION:** Type CHM breakers are used chiefly in steel mills, d-o. railway power plants, automatic substations, and in general wherever breakers are required to operate on high power d-c. supply systems at 550 to 750 volts with the minimum of maintenance.

**MOUNTING:** Panel mounted breakers are mounted on thick slabs of insulating material for bolting to steel framework. Pedestal mounted breakers are built on individual pedestals for bolting to the floor.

There is no difference in rating between the two forms of mounting but pedestal mounting is preferred where the heaviest duty is imposed due to its greater inherent mechanical strength.

**GENERAL:** In these instructions, somewhat more than the usual proportion of space is taken up by descriptions of the several parts of the breaker, because many of the details are worked out on principles that apply only where extremely high currents have to be considered, and an explanation of the reasons for such special features should be helpful in the operation and maintenance of the apparatus. Also, some of the mechanism details which are not easily seen when looking at the completely assembled breaker are described or explained by reference to the figure included herein.

High interrupting capacity is obtained by quick opening, to a wide air gap, of contacts tipped with arc resisting alloys and supplemented by heavy arcing horns, these parts being massive enough to withstand a heavy flash without serious burning.

In addition to the contact details for minimizing the heating effects of the arc, all parts have exceptional mechanical strength in order to withstand the severe mechanical stresses resulting from the magnetic effect of the short-circuit currents that the apparatus may be required to interrupt.

By arranging the contacts with the laminated stationary brush and on the inside of the magnetic loop formed by the studs and contact-bridging details, the magnetic force is utilized to increase the brush pressure during the interval between the occurrence of a short-circuit and the release of the breaker latch. The solid copper bridging member is substantial enough to resist the magnetic force bending it away from the brushes but if it were laminated, as in the standard arrangement of breakers for lower interrupting duty, the outer laminations would have their



Fig. 2 - Pedestal Mounted Breaker

pressure reduced or might even be "blown-off" the stationary contact before the latch could have time to release.

The main contact brushes are built up of straight sections of copper strap of equal length, riveted together in groups forming equal angles at the ends, and clamped to make permanent contact with the stud heads at one end and to connect with the bridging contact at the other. There is an inner and an outer row of laminations, held by concealed bolts on the inner row, in addition to the bolts passing through the outside clamp.

**CIRCUIT INTERRUPTING DETAILS:** Main contact parts, both the laminated stationary brushes and the solid copper bridge, are silver plated to maintain low contact resistance over a long period of service.

When the breaker opens, the main

Types C11A1 Air Circuit-Breaker

contacts separate first and the entire current is carried momentarily by the secondary and arcing contacts. A flexible shunt maintains electrical connection at all times between the lower stationary contact and the lower end of the bridging contact, thus preventing any potential difference that could cause an arc to form at that end.

Secondary contacts below the upper stationary contacts are faced with an alloy having low contact resistance which at the same time will endure considerable arcing without injury to the contact surface. Arcs form on these parts only on the heavier interruptions. A fibre barrier prevents such arcs from flashing along the surface to the main brush. After the secondary contacts part, the current is carried by the arcing contacts at the upper end of the breaker. These arcing contacts have low resistance due to the large copper-to-bronze contact surface between the sides of the movable part and the jaws of the stationary part between which the movable part enters. Good contact between the stationary jaws and the movable arcing contact is assured by a self aligning mounting of the stationary jaws, and springs which exert pressure in the direction of the contact surfaces. Travel of the jaws is limited, so that there is always room for the moving contact to enter the space between them.

As these contacts, last in the circuit, approach the point where they separate, their curved edges, which are below the plane of the contact surfaces make the final lines of contact whereon the arc forms when they part. These curved edges are equipped with tips of an alloy having high arc-resisting

properties. The arc formed on the tips is forced immediately by magnetic repulsion into a pair of arcing horns directly above, and in metallic contact with the point of formation of the arc. These horns are solid castings of a special bronze which resists arcing and are massive enough to absorb a great deal of heat without excessive burning at the surface. Accelerating springs assist in rapidly widening the air gap. As the breaker is single-pole and trips free of the operating mechanism, there is no unnecessary weight to retard its speed.

**BUMPER:** A combination pneumatic and rubber pad bumper brings the moving parts to rest. First, the moving arm strikes a thick rubber pad which is mounted on the top of an air dash-pot. Close fitting, and the use of piston rings, prevent an appreciable escape of air from the dash-pot at the moment of impact and provide an air cushion for bringing the parts to rest without jarring. A ball valve in the piston of the dash-pot obstructs the escape of air when the piston is pressed down but allows air to enter freely when the parts are retrieved to normal position by a spring on the inside of the bumper.

**ELECTRIC OPERATING MECHANISM:** Normally, the breaker is closed by means of an electromagnet built into the lower end. A detachable extension handle which fits into the same closing lever that is operated by the electromagnet provides for manual operation in an emergency or when inspecting or making adjustments. The electromagnet is a solenoid with round stationary and movable cores on the inside and a rectangular frame completing the magnetic cir-

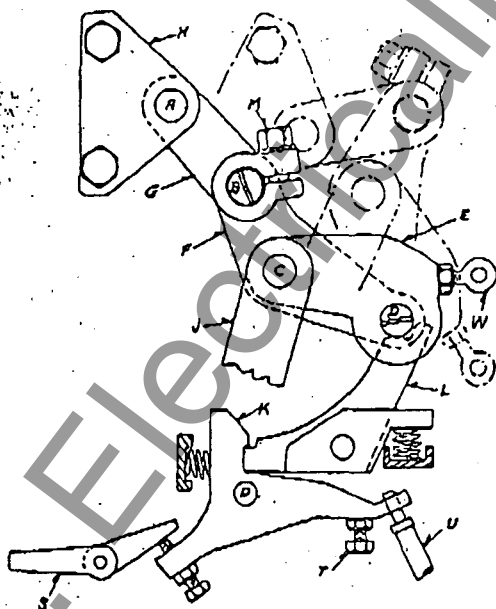

SOLID LINES SHOW CLOSED POSITION  
BROKEN LINES SHOW OPEN POSITION

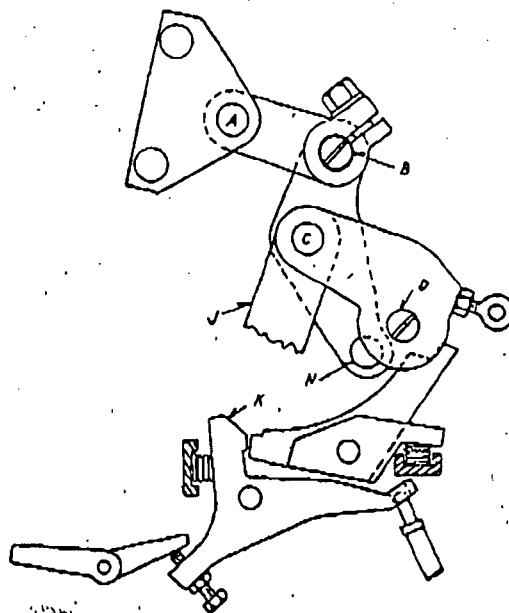

TRIPPING FREE - (PARTLY OPEN POSITION)

Fig. 3 - Action of the Latch and Toggle Mechanism

## Type CHM Air Circuit-Breaker

cuit on the outside. Piston rings and a close fitting brass cylinder between core and coil form an air cushion which together with the damping effect of the currents induced in the brass cylinder, prevent slamming and maintain a reasonably uniform closing speed over a wide range of control voltage.

Figure 3 is for the purpose of explaining the action of the latch and toggle mechanism. When the breaker is fully closed and latched, as shown by solid lines, or when retrieved by the springs immediately after opening, the operating lever E and the link F are locked together to act as a single piece. Toggle link (F), latch, lever (L) and trigger (K) retrieve automatically after tripping, so that E and F are already locked together at the beginning of the closing stroke.

When the closing coil is energized the closing magnet pulls downward through intermediate levers on the link J and pin C at one end of the operating lever E. The other end of E is pivoted on stationary pins D. Lever E is a wide-bronze casting with two bearings at each end. Fixed pivots at D, around which E turns extend only to the inner ends of the two bearings at that end of E. Link F, pivoted on pin C, is located with its vertical center line in the same plane with the vertical center line of E. Link F carries the latch roller which, except during a tripping operation, is held by the latch L in a direct line with the pins D. Centers C and D being equidistant on lever E and link F, E and F act as a single piece as long as the latch holds the end of F in the position of alignment with pins D.

Before closing, the several parts are in the position shown by broken lines in the figure. After closing, the toggle formed on the centers A B D is over center and is prevented by permanently fixed stops from going beyond a predetermined position. This toggle makes a rigid support for holding the bridging contact against the stationary brushes.

The opening toggle A B C is held closed by the latch lever L and the release of this latch lever by trigger K permits this toggle to collapse thus opening the breaker.

**OVERLOAD TRIP:** Overload tripping is controlled by magnetic attraction between the steel frame of the breaker serving as the poles of a magnet in which the studs and main contacts serve as a one turn coil, and a T-shaped armature located centrally below the mechanism. A calibrating ring and guide surrounding the stem of the T armature provide an adjustment for varying the pressure of the armature spring. As the ring turns to the right or left the spring pressure is lowered or raised thus changing the force required by the overload magnet to pick up the armature.

Currents that will pick up the armature and trip the breaker are engraved on a scale plate. The trip point is changed by loosening the thumb screw at the front of the frame and turning the ring until the white index line crossing the center of the pin sock-

et is in line with the scale reading for the trip current desired.

The standard range of calibration is 100% to 200% of breaker rating in five steps 100-125-150-175 and 200%.

**INVERSE TIME LIMIT ATTACHMENT:** The inverse time limit attachment prevents the breaker tripping on short time overloads. This attachment is calibrated without oil. With current flowing through the breaker the same as the calibration setting and with oil in the pot the armature will not pick up. The current flowing must be more than the calibration setting before the breaker will trip.

The inverse time limit attachment used on this breaker is the sucker type. The sucker (which is a smooth surfaced metal disc is attached to the armature and normally rests on the smooth bottom surface of the pot containing a small quantity of oil (approximately 1/8" deep). The resulting sucker action retards the starting movement of the overload armature unless the overload which occurs is very heavy. A considerable time will elapse before the armature can move. The amount of surface in contact between the sucker and pot can be varied, thus providing variation in time limit. Further variation can be obtained by using oils of different viscosities. To keep the inverse time limit in good working order it is necessary that the oil be kept clean. A single particle of dirt between the two contact surfaces will sometimes greatly reduce the time lag. If imperfections appear on the contact surfaces due to bruising or other causes all high spots should be removed with a scraper.

CARE SHOULD BE TAKEN NOT TO INTERCHANGE OVERLOAD DETAILS.

**INSTANTANEOUS TRIP:** The instantaneous trip attachment is the same as the inverse time limit attachment except no oil is used in the pot and the breaker will trip when the current flowing through the breaker is the same as the calibration setting.

The calibration setting should not be set lower than the minimum calibration point or higher than the maximum calibration point.

**BUS CONNECTIONS:** Laminated studs are used in all of these breakers. Horizontal or vertical laminations can be had in any combination required. When the overload trip is calibrated, current is brought to the breaker through bus bars in the position that corresponds with the position to be occupied by bus bars when the breaker is in service. If a change in bus lay-out is made, the calibration of the overload trip should be checked. There may be an appreciable change of calibration, especially in the higher rated breakers.

**INSPECTION AND MAINTENANCE:** Periodic inspection of all breakers in service is recommended. Routine inspections should be scheduled according to the severity of the service, six-month inter-

## Type CHM Air Circuit-Breaker

vals being suitable for the average installation. A special inspection should be made as soon as possible after a breaker has been subjected to extraordinarily heavy duty. A little attention at the right time may prevent the need of repairs later on.

Good condition of auxiliary and arcing contacts is necessary in order that they will protect the main contacts. Burns and roughening of the contact surfaces should be smoothed off with fine sandpaper, or a file if necessary. Sandpaper should never be used on silver plated contacts. Where there is exposure to dirt that cannot be wiped off with a dry cloth or waste, a liquid cleaner such as carbon tetrachloride may be used sparingly but the liquid should not be left to dry on the surfaces.

Contact adjustment for regulating the pressure of the bridge against the brushes is made by means of an eccentric pin in the toggle links. Referring to the figure, the eccentric pin is located at B, connecting links F and G. By loosening the bolt M and turning the eccentric pin with a screw driver, the effective length of the two links can be varied sufficiently to provide any necessary change of pressure.

The air outlets on the bumper and closing magnet dash-pots are not adjustable. Beyond keeping the vents free from accumulation of dirt, they need no attention.

The trigger is fitted with adjustments for adapting it to the mechanical contacts with the tripping devices. Hexagonal head screws with lock nuts are used for adjusting the distance which the overload trip armature must travel from the time it is picked up until it strikes the trigger, and for setting the normal position of the shunt trip lever. Hexagonal nuts on the operating rod connecting the undervoltage release attachment are used for a similar purpose. Adjustment of the distance between the trigger and the overload trip armature does not change the tripping current but regulates the force with which the trigger is struck. Increasing the distance increases, and decreasing the distance decreases, the hammer effect. Similarly, adjustment of the position of the shunt trip lever by turning the adjusting screw clockwise decreases the force with which the shunt trip plunger strikes and the reverse adjustment has the reverse effect. When making either of these adjustments, a safe margin of travel within the limiting positions of the armatures must be retained. A good way to check the adjustment of any of the tripping devices is to push the tripping armature to trip position by hand with the breaker in closed position. Tripping should occur an instant before the armature reaches the end of its travel.

**ATTACHMENTS:** Two auxiliary switches, one nine-pole and the other two-pole, are used in the standard equipment. They are of the same general construction as the Westinghouse type W instrument and control switches. Current is cut off the closing coil by one-pole of the two-pole switch making con-

tact during the closing stroke which de-energizes a relay that opens the circuit after the breaker is latched. Several control connections are made by the nine-pole switch. These include bell alarm or signal lamps, shunt trip and undervoltage trip. As a rule, one or more sets of contacts are available for special connections that may be required in individual installations. Positions of contacts are arranged to open the circuits to the shunt coils of tripping attachments and close the signal contacts when the breaker opens.

Adjustments of the switches are made by varying the lengths of the parts connecting them with the breaker. Lengthening or shortening the operating rod advances or retards, respectively, the making or breaking of contact on the down stroke and has the reverse effect when closing the breaker; lengthening or shortening the arm extending from the breaker mechanism increases or decreases, respectively, the total travel of the switch segments.

**SHUNT TRIP ATTACHMENT:** The shunt trip magnet is of the solenoid type, the movable core of which is pulled towards the stationary core when the shunt coil is energized. Movement of the core trips the breaker and the coil is immediately cut out of the circuit by the auxiliary switch. This is necessary since the shunt trip coil is short time rated and would soon burn out if the voltage were applied for any length of time.

A brass washer is placed between the moving and stationary core to prevent "freezing" due to residual magnetism. This permits the moving core to return to its normal position after the coil is de-energized and it is then ready to again perform its tripping function. Absence of this brass washer will permit sufficient residual magnetism to hold the movable core against the stationary core even after the coil is de-energized and it will then be impossible to trip the breaker open by means of the shunt trip device, until the movable core is forcibly retrieved or until the residual magnetism disappears and the core drops back of its own accord.

The standard range of coil voltage over which the shunt trip mechanism operates is 56% to 112% of normal rated coil voltage.

**UNDERVOLTAGE RELEASE ATTACHMENT:** The undervoltage release attachment is mounted on the front of the closing magnet. It contains an electromagnet having a stationary core and a movable armature which is hinged at one end. As long as the coil in this attachment is energized at any voltage from maximum down to about 80% of normal, the armature is held against the core and does not interfere with the operation of the breaker. If the voltage falls or drops below about half of normal, a spring pulls the armature away from the magnet and drives a trip rod against the breaker trigger, thus releasing the latch. The breaker cannot be re-latched until 80% or more of control voltage

Type CISM Air Circuit-Breaker

is again applied to the coil.

**OPERATION COUNTER:** An operation counter at the front of the auxiliary switch on the right hand side of the breaker registers the total number of operations of the breaker. Connections with the operating lever on the counter is made through a spring

link which absorbs the shock of operation from a quick moving arm. No adjustment is likely to be needed, but in case the last figure on the dial gets out of line, it can be corrected by loosening the clamp at the inner end of the lever on the counter and turning the shaft through a small angle before tightening again.

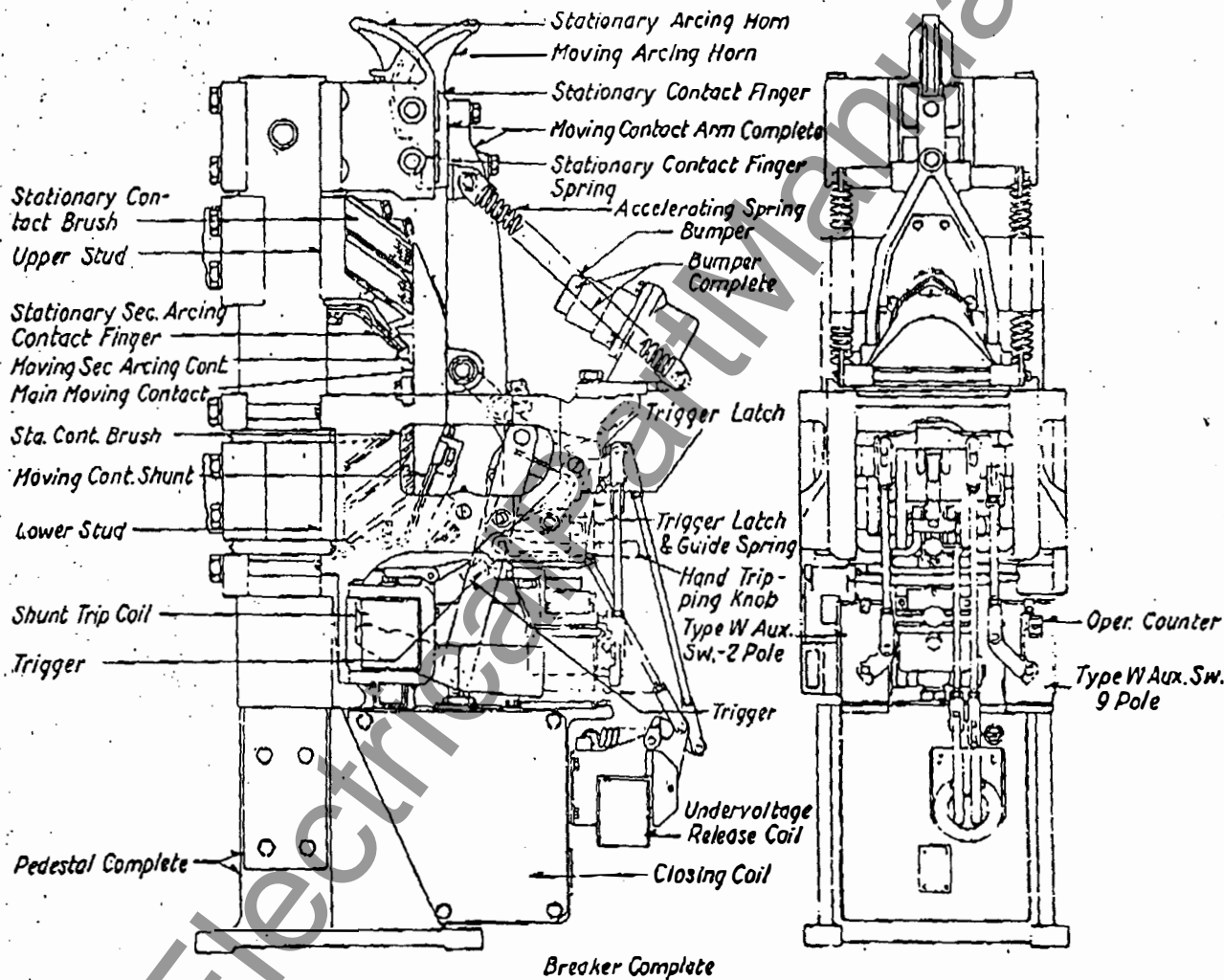

FIG. 4

Type CHM Air Circuit-Breaker

WESTINGHOUSE RENEWAL PARTS DATA

Recommended Stock of Renewal Parts

TYPE CHM AIR CIRCUIT BREAKER

Indoor Service - Panel or Pedestal Mounted  
Electrically Operated - Overload trip  
2000 to 10,000 Amperes - 750 Volts D-C - Single Pole - Single Throw

The following is a list of the Parts on this apparatus that are most subject to wear in ordinary operation and to damage or breakage due to possible abnormal conditions.

For Illustration of Parts, See Figure 4

Breakers in use up to and including	Description	Style Number	No. Req.	Recommended for Stock	
				1	5
Breaker Complete		.....	1	0	0
Moving Contact Arm Complete		+	1	0	0
Dumper Complete.		+	1	0	0
*Bumper Spring - Inner.		1 041 850	1	0	1
*Bumper Spring - Outer.		1 041 849	1	0	1
Bumper.		1 074 112	1	0	1
Main Moving Contact		+	1	0	0
Moving Secondary Arcing Contact		1 035 476	1	1	2
Moving Arcing Horn.		1 035 460	1	1	2
Moving Contact Shunt - Left Hand		+	2	0	2
Moving Contact Shunt - Right Hand.		+	2	0	2
Stationary Contact Finger		1 074 113	2	2	4
Stationary Contact Finger Spring.		946 830	4	1	2
Stationary Arcing Horn		+	1	1	2
Upper Stud		+	1	0	0
Stationary Contact Brush.		See Table	-	1	2
Stationary Secondary Arcing Contact Finger.		1 014 278	2	2	4
Lower Stud		+	1	0	0
Stationary Contact Brush.		See Table	-	1	2
Accelerating Spring		1 074 114	2	1	2
Trigger		+	1	0	1
*Trigger Spring.		+	1	0	1
Trigger Latch		+	1	0	1
Trigger Latch Spring.		+	1	0	1
Trigger Latch Guide Spring.		+	1	0	1
Hand Tripping Knob		677 290	1	0	0
Pedestal Complete.		+	1	0	0
Operation Counter.		478 294	1	0	0
Closing Coil		+	1	0	1
Shunt Trip Coil		+	1	0	1
Undervoltage Release Coil		+	1	0	1
Type W Auxiliary Switch - 2 Pole.		1 019 406	1	0	0
*Moving Contact Segment		545 626	2	0	1
*Stationary Contact Finger		519 279	4	2	4
Type W Auxiliary Switch - 9 Pole.		1 019 407	1	0	0
*Moving Contact Segment - Small		545 626	7	1	3
*Moving Contact Segment - Large		808 922	2	0	1
*Stationary Contact Finger		519 279	18	9	18

\* Not Illustrated

+ Identification of these parts vary with different ratings and characteristics of Breakers. If these parts are desired, Renewal Parts Data will be supplied for your Breaker. Give the complete nameplate reading with your request to the nearest Sales Office of the Company.

Parts indented are included in the part under which they are indented

## Type CHM Air Circuit-Breaker

TABLE

Description	Style Number			
	1 014 271	1 014 272	1 014 273	1 014 274
Required				
Stationary Contact Brush - 2000 Amperes	1	-	-	-
Stationary Contact Brush - 3000 Amperes	-	1	-	-
Stationary Contact Brush - 4000 Amperes	2	-	-	-
Stationary Contact Brush - 6000 Amperes	-	1	-	1
Stationary Contact Brush - 8000 Amperes	2	-	2	-
Stationary Contact Brush -10000 Amperes	1	1	1	1

ORDERING INSTRUCTIONS

When ordering Renewal Parts, always specify the name of the part wanted as shown on the illustrations in this Instruction Book, giving Shop Order Number, and the type of Circuit Breaker as shown on the nameplate. For example:

One Main Moving Contact, 4000 Amperes, for Type CHM Air Circuit Breaker, S.O. 28-Y-997, shown in Instruction Book 5772-A, Figure 4.

To avoid delays and misunderstandings, note carefully the following points:

1. Send all correspondence and orders to the nearest Sales Office of the Company.
2. State whether shipment is to be made by freight, express or parcel post. In the absence of instructions, goods will be shipped at our discretion. Parcel post shipments will be insured only on request. All shipments are at purchaser's risk.
3. Small orders should be combined so as to amount to a value of at least \$1.00 net. Where the total of the sale is less than this, the material will be invoiced at \$1.00

# Westinghouse

## Type CHM Air Circuit-Breaker

### **MB Industrial Equipment Inc.**

P.O. Box 14 152 West 4th Avenue  
Tarentum, PA 15084

Phone: (724) 226-8336 Fax: (724) 226-9760

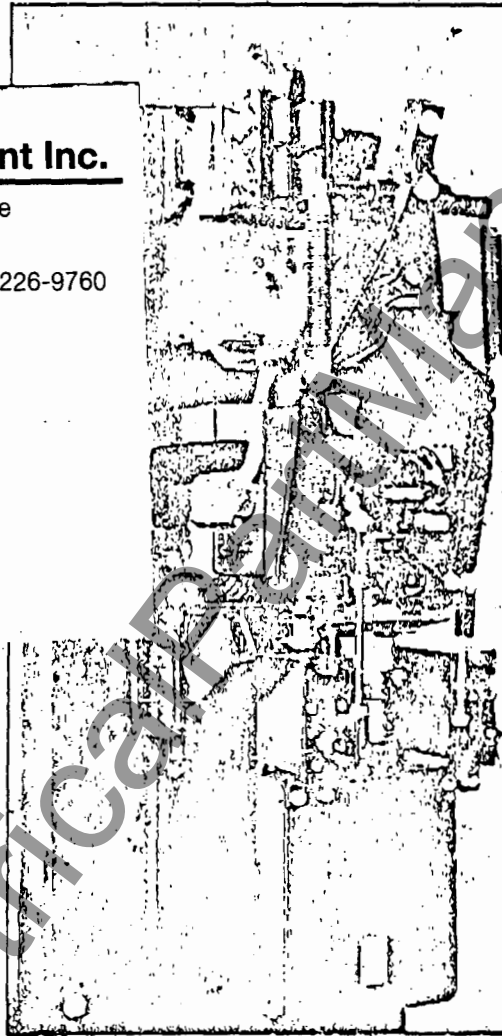

FIG. 1—PANEL MOUNTED BREAKER

Westinghouse Electric Corporation  
East Pittsburgh, Pa.

Printed in U.S.A. (Reprinted 8-82)

1B 5772-A  
Filing No. 35-000



[www.ElectricalPartManuals.com](http://www.ElectricalPartManuals.com)

## Type CHM Air Circuit-Breaker

INDEXINSTRUCTIONS FOR OPERATION

Rating . . . . .	4
Application . . . . .	4
Mounting . . . . .	4
General. . . . .	4
Circuit Interrupting Details. . . . .	4
Bumper . . . . .	5
Electric Operating Mechanism. . . . .	5
Overload Trip. . . . .	6
Inverse Time Limit Attachment . . . . .	6
Instantaneous Trip . . . . .	6
Bus Connections . . . . .	6
Inspection and Maintenance . . . . .	6
Attachments . . . . .	7
Shunt Trip Attachment . . . . .	7
Undervoltage Release Attachment. . . . .	7
Operation Counter . . . . .	8
Renewal Parts Data . . . . .	9
Table . . . . .	10
Ordering Instructions . . . . .	10

# Important

## Type CHM Air Circuit-Breaker

### Keep Main Copper Contacts Clean

In contrast to copper oxide, silver oxide or sulphide is a comparatively good conductor so that circuit-breakers having silver plated main contacts do not require the removal of oxide. As a matter of fact sandpaper should never be applied to silver plated contacts since the useful silver plating would thereby be removed.

### Maintain Proper Main Contact Pressure

While it is true that after the main brush contacts have been properly adjusted they will remain so indefinitely, occasional inspections should be made to see that all adjusting screws are tight and if any of these screws are found loose to see that the brush adjustment has not shifted.

### Lubrication

Lubrifications of the various parts of the mechanism as applied at the factory should be sufficient for many months of service. Experience indicates that lubrication is generally applied too freely rather than insufficiently. If a bearing seems to require lubrication, apply only sufficient oil to provide a thin film on the working parts. Excessive use of oil promotes the accumulation of dirt, and oil is very detrimental to any contact surface to which it may spread or upon which it may be thrown. Alemite fittings are provided for the lubrication of the main toggle pin bearings. It is very important that these bearings have lubrication at all times.

## Type CHM Air Circuit-Breaker

## Instructions for Operation

**RATING:** 2000 to 10,000 amperes, 750 volts  
D-C Single Pole. Panel or Pedestal  
Mounting.

**APPLICATION:** Type CHM breakers are used chiefly in steel mills, d-o. railway power plants, automatic substations, and in general wherever breakers are required to operate on high power d-c. supply systems at 550 to 750 volts with the minimum of maintenance.

**MOUNTING:** Panel mounted breakers are mounted on thick slabs of insulating material for bolting to steel framework. Pedestal mounted breakers are built on individual pedestals for bolting to the floor.

There is no difference in rating between the two forms of mounting but pedestal mounting is preferred where the heaviest duty is imposed due to its greater inherent mechanical strength.

**GENERAL:** In these instructions, somewhat more than the usual proportion of space is taken up by descriptions of the several parts of the breaker, because many of the details are worked out on principles that apply only where extremely high currents have to be considered, and an explanation of the reasons for such special features should be helpful in the operation and maintenance of the apparatus. Also, some of the mechanism details which are not easily seen when looking at the completely assembled breaker are described or explained by reference to the figure included herein.

High interrupting capacity is obtained by quick opening, to a wide air gap, of contacts tipped with arc resisting alloys and supplemented by heavy arcing horns, these parts being massive enough to withstand a heavy flash without serious burning.

In addition to the contact details for minimizing the heating effects of the arc, all parts have exceptional mechanical strength in order to withstand the severe mechanical stresses resulting from the magnetic effect of the short-circuit currents that the apparatus may be required to interrupt.

By arranging the contacts with the laminated stationary brush and on the inside of the magnetic loop formed by the studs and contact-bridging details, the magnetic force is utilized to increase the brush pressure during the interval between the occurrence of a short-circuit and the release of the breaker latch. The solid copper bridging member is substantial enough to resist the magnetic force being held away from the brushes but if it were laminated, as in the standard arrangement of breakers for lower interrupting duty, the outer laminations would have their



Fig. 2 - Pedestal Mounted Breaker

pressure reduced or might even be "blown-off" the stationary contact before the latch could have time to release.

The main contact brushes are built up of straight sections of copper strap of equal length, riveted together in groups forming equal angles at the ends, and clamped to make permanent contact with the stud heads at one end and to connect with the bridging contact at the other. There is an inner and an outer row of laminations, held by concealed bolts on the inner row, in addition to the bolts passing through the outside clamp.

**CIRCUIT INTERRUPTING DETAILS:** Main contact parts, both the laminated stationary brushes and the solid copper bridge, are silver plated to maintain low contact resistance over a long period of service.

When the breaker opens, the main

*Type CHAM Air Circuit-Breaker*

contacts separate first and the entire current is carried momentarily by the secondary and arcing contacts. A flexible shunt maintains electrical connection at all times between the lower stationary contact and the lower end of the bridging contact, thus preventing any potential difference that could cause an arc to form at that end.

Secondary contacts below the upper stationary contacts are faced with an alloy having low contact resistance which at the same time will endure considerable arcing without injury to the contact surface. Arcs form on these parts only on the heavier interruptions. A fibre barrier prevents such arcs from flashing along the surface to the main brush. After the secondary contacts part, the current is carried by the arcing contacts at the upper end of the breaker. These arcing contacts have low resistance due to the large copper-to-bronze contact surface between the sides of the movable part and the jaws of the stationary part between which the movable part enters. Good contact between the stationary jaws and the movable arcing contact is assured by a self aligning mounting of the stationary jaws, and springs which exert pressure in the direction of the contact surfaces. Travel of the jaws is limited, so that there is always room for the moving contact to enter the space between them.

As these contacts, last in the circuit, approach the point where they separate, their curved edges, which are below the plane of the contact surfaces make the final lines of contact whereon the arc forms when they part. These curved edges are equipped with tips of an alloy having high arc-resisting

properties. The arc formed on the tips is forced immediately by magnetic repulsion into a pair of arcing horns directly above, and in metallic contact with the point of formation of the arc. These horns are solid castings of a special bronze which resists arcing and are massive enough to absorb a great deal of heat without excessive burning at the surface. Accelerating springs assist in rapidly widening the air gap. As the breaker is single-pole and trips free of the operating mechanism, there is no unnecessary weight to retard its speed.

**BUMPER:** A combination pneumatic and rubber pad bumper brings the moving parts to rest. First, the moving arm strikes a thick rubber pad which is mounted on the top of an air dash-pot. Close fitting, and the use of piston rings, prevent an appreciable escape of air from the dash-pot at the moment of impact and provide an air cushion for bringing the parts to rest without jarring. A ball valve in the piston of the dash-pot obstructs the escape of air when the piston is pressed down but allows air to enter freely when the parts are retrieved to normal position by a spring on the inside of the bumper.

**ELECTRIC OPERATING MECHANISM:** Normally, the breaker is closed by means of an electromagnet built into the lower end. A detachable extension handle which fits into the same closing lever that is operated by the electromagnet provides for manual operation in an emergency or when inspecting or making adjustments. The electromagnet is a solenoid with round stationary and movable cores on the inside and a rectangular frame completing the magnetic cir-

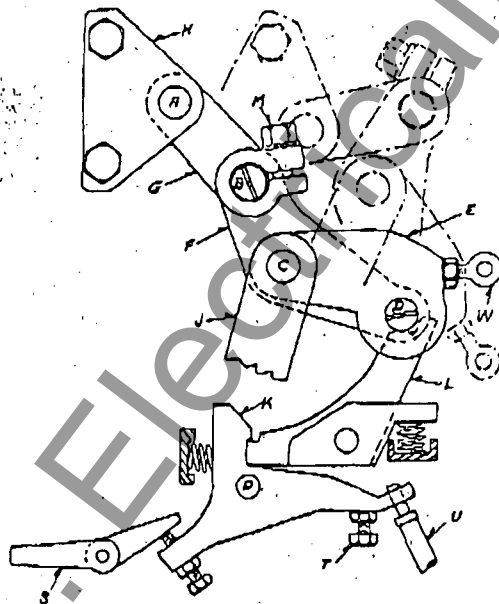

SOLID LINES SHOW CLOSED POSITION  
BROKEN LINES SHOW OPEN POSITION

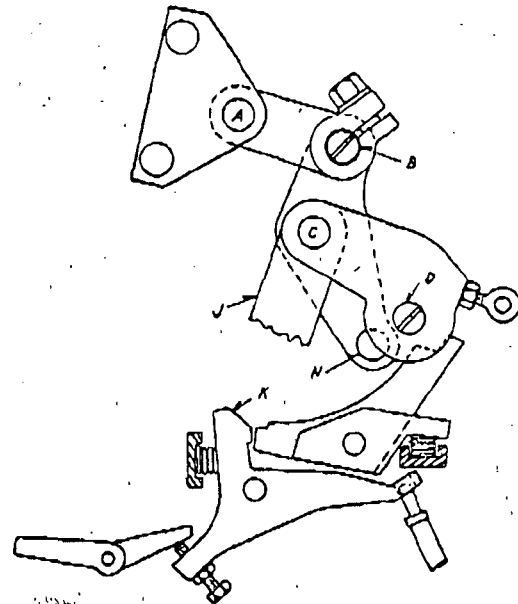

TRIPPING FREE - (PARTLY OPEN POSITION)

Fig. 3 - Action of the Latch and Toggle Mechanism

## Type CIM Air Circuit-Breaker

cuit on the outside. Piston rings and a close fitting brass cylinder between core and coil form an air cushion which together with the damping effect of the currents induced in the brass cylinder, prevent slamming and maintain a reasonably uniform closing speed over a wide range of control voltage.

Figure 3 is for the purpose of explaining the action of the latch and toggle mechanism. When the breaker is fully closed and latched, as shown by solid lines, or when retrieved by the springs immediately after opening, the operating lever E and the link F are locked together to act as a single piece. Toggle link (T), latch, lever (L) and trigger (K) retrieve automatically after tripping, so that E and F are already locked together at the beginning of the closing stroke.

When the closing coil is energized the closing magnet pulls downward through intermediate levers on the link J and pin C at one end of the operating lever E. The other end of E is pivoted on stationary pins D. Lever E is a wide-bronze casting with two bearings at each end. Fixed pivots at D, around which E turns extend only to the inner ends of the two bearings at that end of E. Link F, pivoted on pin C, is located with its vertical center line in the same plane with the vertical center line of E. Link F carries the latch roller which, except during a tripping operation, is held by the latch L in a direct line with the pins D. Centers C and D being equidistant on lever E and link F, E and F act as a single piece as long as the latch holds the end of F in the position of alignment with pins D.

Before closing, the several parts are in the position shown by broken lines in the figure. After closing, the toggle formed on the centers A B D is over center and is prevented by permanently fixed stops from going beyond a predetermined position. This toggle makes a rigid support for holding the bridging contact against the stationary brushes.

The opening toggle A B C is held closed by the latch lever L and the release of this latch lever by trigger K permits this toggle to collapse thus opening the breaker.

**OVERLOAD TRIP:** Overload tripping is controlled by magnetic attraction between the steel frame of the breaker serving as the poles of a magnet in which the studs and main contacts serve as a one turn coil, and a T-shaped armature located centrally below the mechanism. A calibrating ring and guide surrounding the stem of the T armature provide an adjustment for varying the pressure of the armature spring. As the ring turns to the right or left the spring pressure is lowered or raised thus changing the force required by the overload magnet to pick up the armature.

Currents that will pick up the armature and trip the breaker are engraved on a scale plate. The trip point is changed by loosening the thumb screw at the front of the frame and turning the ring until the white index line crossing the center of the pin sock-

et is in line with the scale reading for the trip current desired.

The standard range of calibration is 100% to 200% of breaker rating in five steps 100-125-150-175 and 200%.

**INVERSE TIME LIMIT ATTACHMENT:** The inverse time limit attachment prevents the breaker tripping on short time overloads. This attachment is calibrated without oil. With current flowing through the breaker the same as the calibration setting and with oil in the pot the armature will not pick up. The current flowing must be more than the calibration setting before the breaker will trip.

The inverse time limit attachment used on this breaker is the sucker type. The sucker (which is a smooth surfaced metal disc) is attached to the armature and normally rests on the smooth bottom surface of the pot containing a small quantity of oil (approximately 1/8" deep). The resulting sucker action retards the starting movement of the overload armature unless the overload which occurs is very heavy. A considerable time will elapse before the armature can move. The amount of surface in contact between the sucker and pot can be varied, thus providing variation in time limit. Further variation can be obtained by using oils of different viscosities. To keep the inverse time limit in good working order it is necessary that the oil be kept clean. A single particle of dirt between the two contact surfaces will sometimes greatly reduce the time lag. If imperfections appear on the contact surfaces due to bruising or other causes all high spots should be removed with a scraper.

**CARE SHOULD BE TAKEN NOT TO INTERCHANGE OVERLOAD DETAILS.**

**INSTANTANEOUS TRIP:** The instantaneous trip attachment is the same as the inverse time limit attachment except no oil is used in the pot and the breaker will trip when the current flowing through the breaker is the same as the calibration setting.

The calibration setting should not be set lower than the minimum calibration point or higher than the maximum calibration point.

**BUS CONNECTIONS:** Laminated studs are used in all of these breakers. Horizontal or vertical laminations can be had in any combination required. When the overload trip is calibrated, current is brought to the breaker through bus bars in the position that corresponds with the position to be occupied by bus bars when the breaker is in service. If a change in bus lay-out is made, the calibration of the overload trip should be checked. There may be an appreciable change of calibration, especially in the higher rated breakers.

**INSPECTION AND MAINTENANCE:** Periodic inspection of all breakers in service is recommended. Routine inspections should be scheduled according to the severity of the service, six-month inter-

## Type CIM Air Circuit-Breaker

vals being suitable for the average installation. A special inspection should be made as soon as possible after a breaker has been subjected to extraordinarily heavy duty. A little attention at the right time may prevent the need of repairs later on.

Good condition of auxiliary and arcing contacts is necessary in order that they will protect the main contacts. Burns and roughening of the contact surfaces should be smoothed off with fine sandpaper, or a file if necessary. Sandpaper should never be used on silver plated contacts. Where there is exposure to dirt that cannot be wiped off with a dry cloth or waste, a liquid cleaner such as carbon tetrachloride may be used sparingly but the liquid should not be left to dry on the surfaces.

Contact adjustment for regulating the pressure of the bridge against the brushes is made by means of an eccentric pin in the toggle links. Referring to the figure, the eccentric pin is located at B, connecting links F and G. By loosening the bolt M and turning the eccentric pin with a screw driver, the effective length of the two links can be varied sufficiently to provide any necessary change of pressure.

The air outlets on the bumper and closing magnet dash-pots are not adjustable. Beyond keeping the vents free from accumulation of dirt, they need no attention.

The trigger is fitted with adjustments for adapting it to the mechanical contacts with the tripping devices. Hexagonal head screws with lock nuts are used for adjusting the distance which the overload trip armature must travel from the time it is picked up until it strikes the trigger, and for setting the normal position of the shunt trip lever. Hexagonal nuts on the operating rod connecting the undervoltage release attachment are used for a similar purpose. Adjustment of the distance between the trigger and the overload trip armature does not change the tripping current but regulates the force with which the trigger is struck. Increasing the distance increases, and decreasing the distance decreases, the hammer effect. Similarly, adjustment of the position of the shunt trip lever by turning the adjusting screw clockwise decreases the force with which the shunt trip plunger strikes and the reverse adjustment has the reverse effect. When making either of these adjustments, a safe margin of travel within the limiting positions of the armatures must be retained. A good way to check the adjustment of any of the tripping devices is to push the tripping armature to trip position by hand with the breaker in closed position. Tripping should occur an instant before the armature reaches the end of its travel.

**ATTACHMENTS:** Two auxiliary switches, one nine-pole and the other two-pole, are used in the standard equipment. They are of the same general construction as the Westinghouse type W instrument and control switches. Current is cut off the closing coil by one-pole of the two-pole switch making con-

tact during the closing stroke which de-energizes a relay that opens the circuit after the breaker is latched. Several control connections are made by the nine-pole switch. These include bell alarm or signal lamps, shunt trip and undervoltage trip. As a rule, one or more sets of contacts are available for special connections that may be required in individual installations. Positions of contacts are arranged to open the circuits to the shunt coils of tripping attachments and close the signal contacts when the breaker opens.

Adjustments of the switches are made by varying the lengths of the parts connecting them with the breaker. Lengthening or shortening the operating rod advances or retards, respectively, the making or breaking of contact on the down stroke and has the reverse effect when closing the breaker; lengthening or shortening the arm extending from the breaker mechanism increases or decreases, respectively, the total travel of the switch segments.

**SHUNT TRIP ATTACHMENT:** The shunt trip magnet is of the solenoid type, the movable core of which is pulled towards the stationary core when the shunt coil is energized. Movement of the core trips the breaker and the coil is immediately cut out of the circuit by the auxiliary switch. This is necessary since the shunt trip coil is short time rated and would soon burn out if the voltage were applied for any length of time.

A brass washer is placed between the moving and stationary core to prevent "freezing" due to residual magnetism. This permits the moving core to return to its normal position after the coil is de-energized and it is then ready to again perform its tripping function. Absence of this brass washer will permit sufficient residual magnetism to hold the movable core against the stationary core even after the coil is de-energized and it will then be impossible to trip the breaker open by means of the shunt trip device, until the movable core is forcibly retrieved or until the residual magnetism disappears and the core drops back of its own accord.

The standard range of coil voltage over which the shunt trip mechanism operates is 56% to 112% of normal rated coil voltage.

**UNDERVOLTAGE RELEASE ATTACHMENT:** The undervoltage release attachment is mounted on the front of the closing magnet. It contains an electromagnet having a stationary core and a movable armature which is hinged at one end. As long as the coil in this attachment is energized at any voltage from maximum down to about 80% of normal, the armature is held against the core and does not interfere with the operation of the breaker. If the voltage falls or drops below about half of normal, a spring pulls the armature away from the magnet and drives a trip rod against the breaker trigger, thus releasing the latch. The breaker cannot be re-latched until 80% or more of control voltage

[www.ElectricalPartManuals.com](http://www.ElectricalPartManuals.com)

Type CIM Air Circuit-Breaker

is again applied to the coil.

**OPERATION COUNTER:** An operation counter at the front of the auxiliary switch on the right hand side of the breaker registers the total number of operations of the breaker. Connections with the operating lever on the counter is made through a spring

link which absorbs the shock of operation from a quick moving arm. No adjustment is likely to be needed, but in case the last figure on the dial gets out of line, it can be corrected by loosening the clamp at the inner end of the lever on the counter and turning the shaft through a small angle before tightening again.

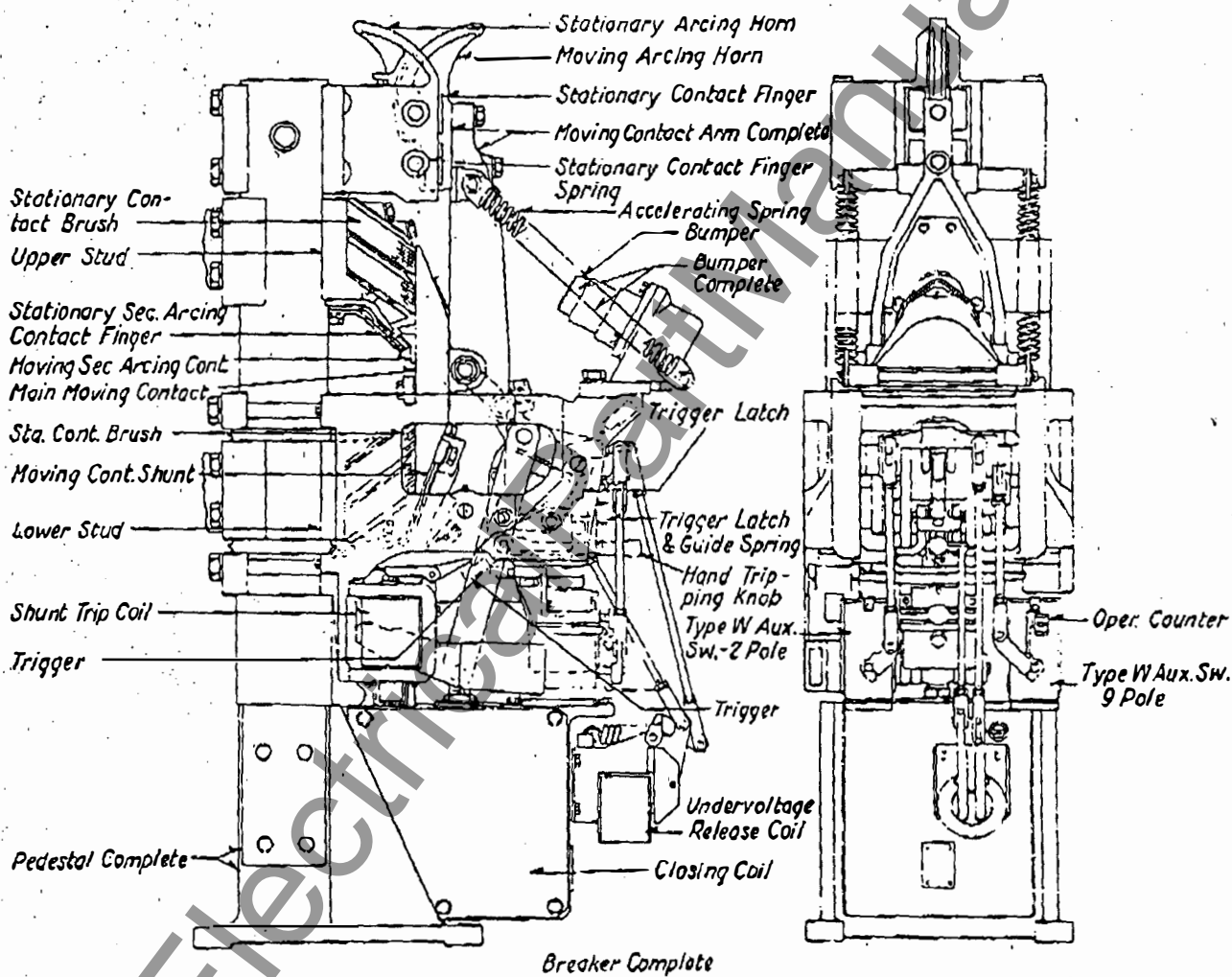

FIG. 4

Type CHM Air Circuit-Breaker

WESTINGHOUSE RENEWAL PARTS DATA

Recommended Stock-of Renewal Parts

TYPE CHM AIR CIRCUIT BREAKER

Indoor Service - Panel or Pedestal Mounted  
Electrically Operated - Overload trip

2000 to 10,000 Amperes - 750 Volts D-C - Single Pole - Single Throw

The following is a list of the Parts on this apparatus that are most subject to wear in ordinary operation and to damage or breakage due to possible abnormal conditions.

For illustration of Parts, See Figure 4

Breakers in use up to and including	Description	Style Number	No. Req	1	5
				Recommended for Stock	
	Breaker Complete	.....	1	0	0
	Moving Contact Arm Complete	+	1	0	0
	Bumper Complete.	+	1	0	0
	*Bumper Spring - Inner.	1 041 850	1	0	1
	*Bumper Spring - Outer.	1 041 849	1	0	1
	Bumper.	1 074 112	1	0	1
	Main Moving Contact	+	1	0	0
	Moving Secondary Arcing Contact	1 035 476	1	1	2
	Moving Arcing Horn.	1 035 460	1	1	2
	Moving Contact Shunt - Left Hand	+	2	0	2
	Moving Contact Shunt - Right Hand.	+	2	0	2
	Stationary Contact Finger	1 074 113	2	2	4
	Stationary Contact Finger Spring.	946 830	4	1	2
	Stationary Arcing Horn	+	1	1	2
	Upper Stud	+	1	0	0
	Stationary Contact Brush.	See Table	-	1	2
	Stationary Secondary Arcing Contact Finger.	1 014 278	2	2	4
	Lower Stud	+	1	0	0
	Stationary Contact Brush.	See Table	-	1	2
	Accelerating Spring	1 074 114	2	1	2
	Trigger	+	1	0	1
	*Trigger Spring.	+	1	0	1
	Trigger Latch	+	1	0	1
	Trigger Latch Spring.	+	1	0	1
	Trigger Latch Guide Spring.	+	1	0	1
	Hand Tripping Knob	677 290	1	0	0
	Pedestal Complete.	+	1	0	0
	Operation Counter.	478 294	1	0	0
	Closing Coil	+	1	0	1
	Shunt Trip Coil	+	1	0	1
	Undervoltage Release Coil	+	1	0	1
	Type W Auxiliary Switch - 2 Pole.	1 019 406	1	0	0
	*Moving Contact Segment	545 626	2	0	1
	*Stationary Contact Finger	519 279	4	2	4
	Type W Auxiliary Switch - 9 Pole.	1 019 407	1	0	0
	*Moving Contact Segment - Small	545 626	7	1	3
	*Moving Contact Segment - Large	808 922	2	0	1
	*Stationary Contact Finger	519 279	18	9	18

\* Not Illustrated

\* Identification of these parts vary with different ratings and characteristics of Breakers. If these parts are desired, Renewal Parts Data will be supplied for your Breaker. Give the complete nameplate reading with your request to the nearest Sales Office of the Company. Parts indented are included in the part under which they are indented

## Type CHM Air Circuit-Breaker

TABLE

Description	Style Number			
	1 014 271	1 014 272	1 014 273	1 014 274
	Required			
Stationary Contact Brush - 2000 Amperes	1	-	-	-
Stationary Contact Brush - 3000 Amperes	-	1	-	-
Stationary Contact Brush - 4000 Amperes	2	-	-	-
Stationary Contact Brush - 6000 Amperes	-	1	-	1
Stationary Contact Brush - 8000 Amperes	2	-	2	-
Stationary Contact Brush -10000 Amperes	1	1	1	1

ORDERING INSTRUCTIONS

When ordering Renewal Parts, always specify the name of the part wanted as shown on the illustrations in this Instruction Book, giving Shop Order Number, and the type of Circuit Breaker as shown on the nameplate. For example:

One Main Moving Contact, 4000 Amperes, for Type CHM Air Circuit Breaker, S.O. 28-Y-997, shown in Instruction Book 5772-A, Figure 4.

To avoid delays and misunderstandings, note carefully the following points:

1. Send all correspondence and orders to the nearest Sales Office of the Company.
2. State whether shipment is to be made by freight, express or parcel post. In the absence of instructions, goods will be shipped at our discretion. Parcel post shipments will be insured only on request. All shipments are at purchaser's risk.
3. Small orders should be combined so as to amount to a value of at least \$1.00 net. Where the total of the sale is less than this, the material will be invoiced at \$1.00