



INSTALLATION • ADJUSTMENTS • MAINTENANCE  
**INSTRUCTIONS**

**OIL CIRCUIT BREAKER**

**Types F-11 and F-22**

**WESTINGHOUSE ELECTRIC CORPORATION**

SWITCHGEAR DIVISION

EAST PITTSBURGH PLANT  
SUPERSEDES I.B. 5229-L

EAST PITTSBURGH, PA.  
DECEMBER, 1954  
(Rep. 11-57) Printed in U.S.A.

# TABLE OF CONTENTS

<b>SHIPPING</b> .....	<b>Page 3</b>
<b>INSTALLATION</b> .....	<b>Pages 4-6</b>
<b>ADJUSTMENT</b> .....	<b>Pages 7-9</b>
<b>MAINTENANCE</b> .....	<b>Pages 10-19</b>
<b>Attachments</b> .....	<b>13</b>

## LIST OF ILLUSTRATIONS

<b>Figure</b>		<b>Page</b>
1	F-11 Single Throw Breaker Unit .....	3
2	F-11 Double Throw Breaker Unit.....	4
3	F-22 Single Throw Breaker Unit.....	5
4	Contacts F-11.....	6
5	Contacts F-22.....	7
6	Switchboard Mounting Assembly.....	8
7	Panel Frame Mounting Assembly.....	9
8	Remote Control Assembly.....	10
9	Pipe Frame Mounting Assembly.....	11
10	Bell Crank Assembly.....	11
11	Single Handle Coverplate.....	12
12	Double Handle Coverplate.....	12
13	Instantaneous Overload Trip.....	13
14	Shunt Trip.....	13
15	Inverse Time Delay Trip.....	14
16	Inverse Time Delay Tripping Curves.....	14
17	Hand Retrieve Undervoltage Trip.....	14
17A	Automatic Retrieve Undervoltage Trip.....	15
18	Auxiliary Switch.....	15
19	Bell Alarm Switch.....	15
20	Double Throw Interlock.....	16
21	Sequence Interlock.....	17
22	Mounting Assembly.....	19

# SHIPPING

The types F-11 and F-22 oil circuit breakers are built on the unit basis, i.e., the breaker unit, the coverplate and the accessories are unit assemblies, packaged and shipped as separate units. Each assembly is inspected, operated and tested before packing to be sure it is correct. Check each package, when opened, against the shipping papers to see that the contents are as listed. Keep the papers

at least until installation is complete. Correspondence will be expedited if the Westinghouse order number, the style number, or other identification marked, on the part or assembly under question and a description are included in the first letter. If possible refer to the part or parts by the names given in this book together with the figure number where it appears.

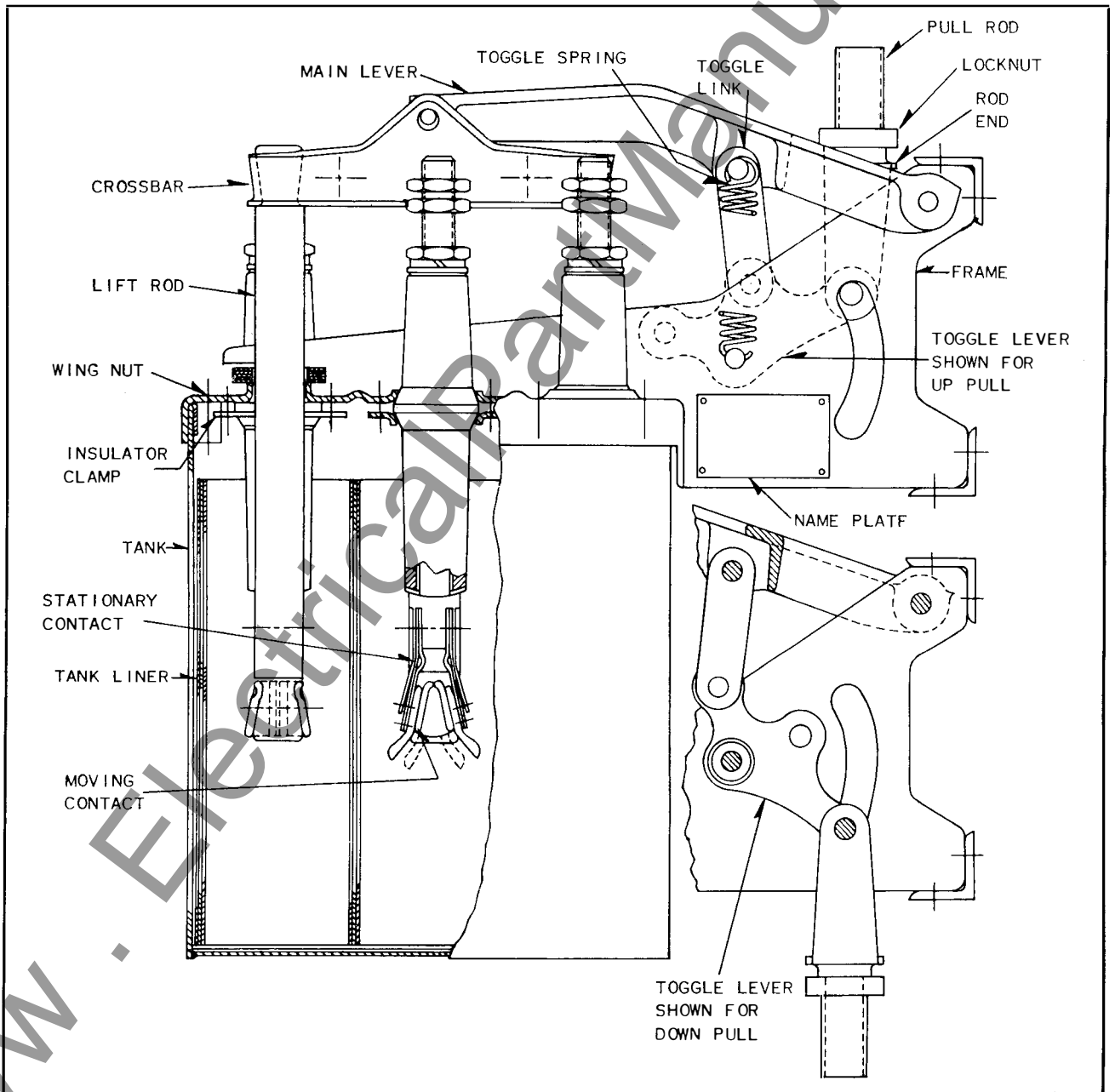

FIG. 1. F-11 Single Throw Breaker Unit

# INSTALLATION

Lay out all the assemblies and parts on the floor or on a bench in approximate position for assembly. Check to see that all required parts are at hand then proceed in approximately the following sequence.

1. Place the bell alarm (Fig. 19) or auxiliary switch (Fig. 18), if they are supplied, in the slot in the coverplate.

2. Place trip coils in coverplate and assemble trip attachments by inserting in holes in bottom of

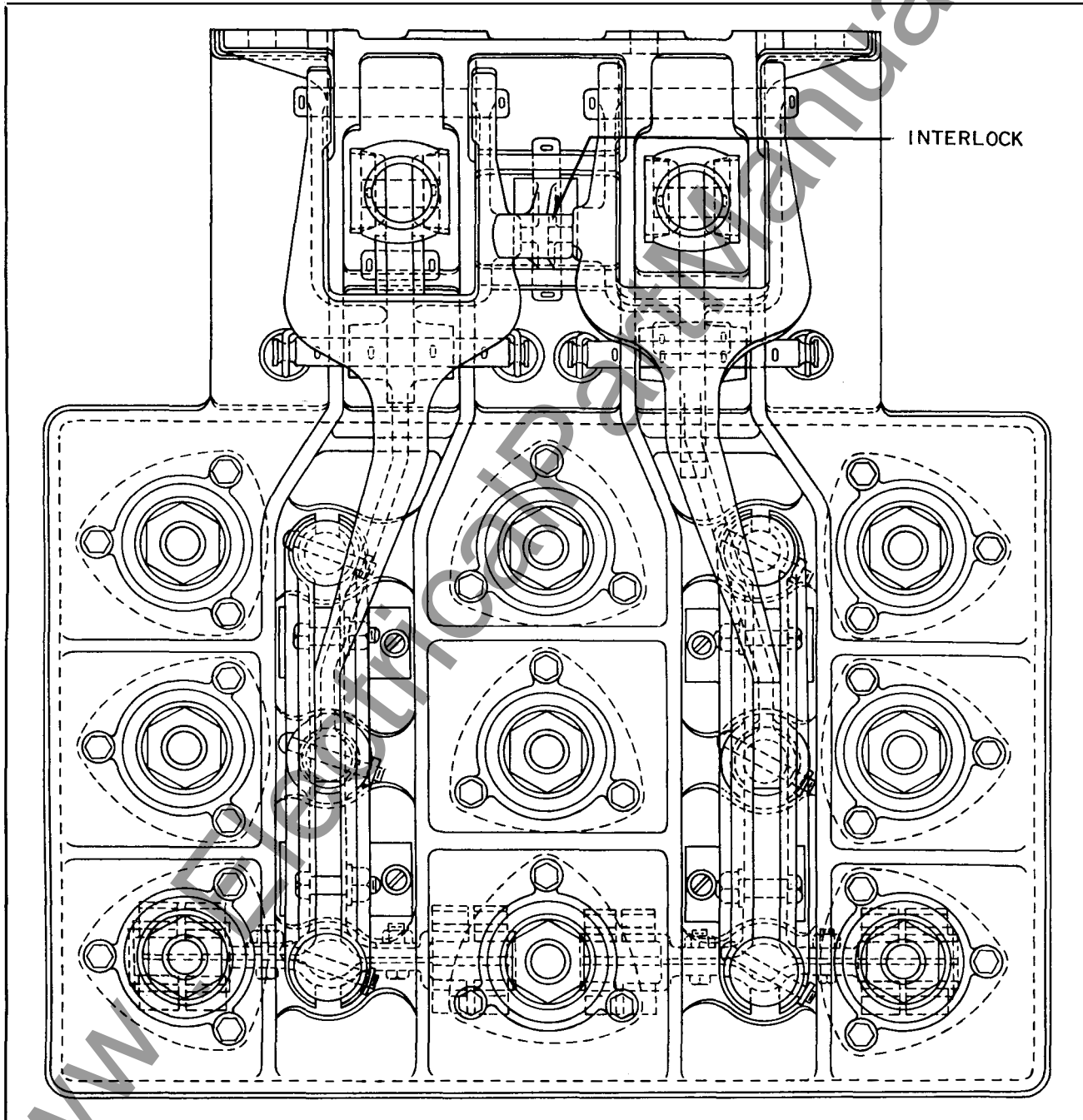

FIG. 2. F-11 Double Throw Breaker Unit

coil box pushing up through coil and top of coil box. Turn calibration scales so they face the front. Fasten in place with nut and lock washer on top of coil box. Wedge coil by driving wedges *below* coil. Wedges should be coated with shellac before driving in to insure they will not come out.

**3.** Place coverplate on switchboard. Make sure handle travels vertically.

**4.** If manual retrieve undervoltage (Fig. 17) is furnished, mount it on left hand coverplate bolt. The automatic retrieve undervoltage (Fig. 17A) is mounted on right hand coverplate bolt.

**5.** If breaker unit is to be mounted in back of switchboard assemble with coverplate. (See Fig. 6)

Note several of the bolts fasten both assemblies. Make sure breaker unit is level with studs vertical.

**6.** If breaker unit and coverplate are to be mounted on a pipe mounting bracket as in Fig. 9 proceed as per 3-4-5 above, the pipe bracket is just a cast iron switchboard to be supported on pipes.

**7.** If breaker unit is to be carried on panel mounting brackets back of and off of switchboard, the assembly will be as in Fig. 7.

**8.** If breaker unit is to be carried on a wall or pipe frame, assembly will be according to Fig. 8. The bell cranks are supplied for mounting on the floor with the accelerating device carrying the spring next to the breaker unit. If bell cranks are to

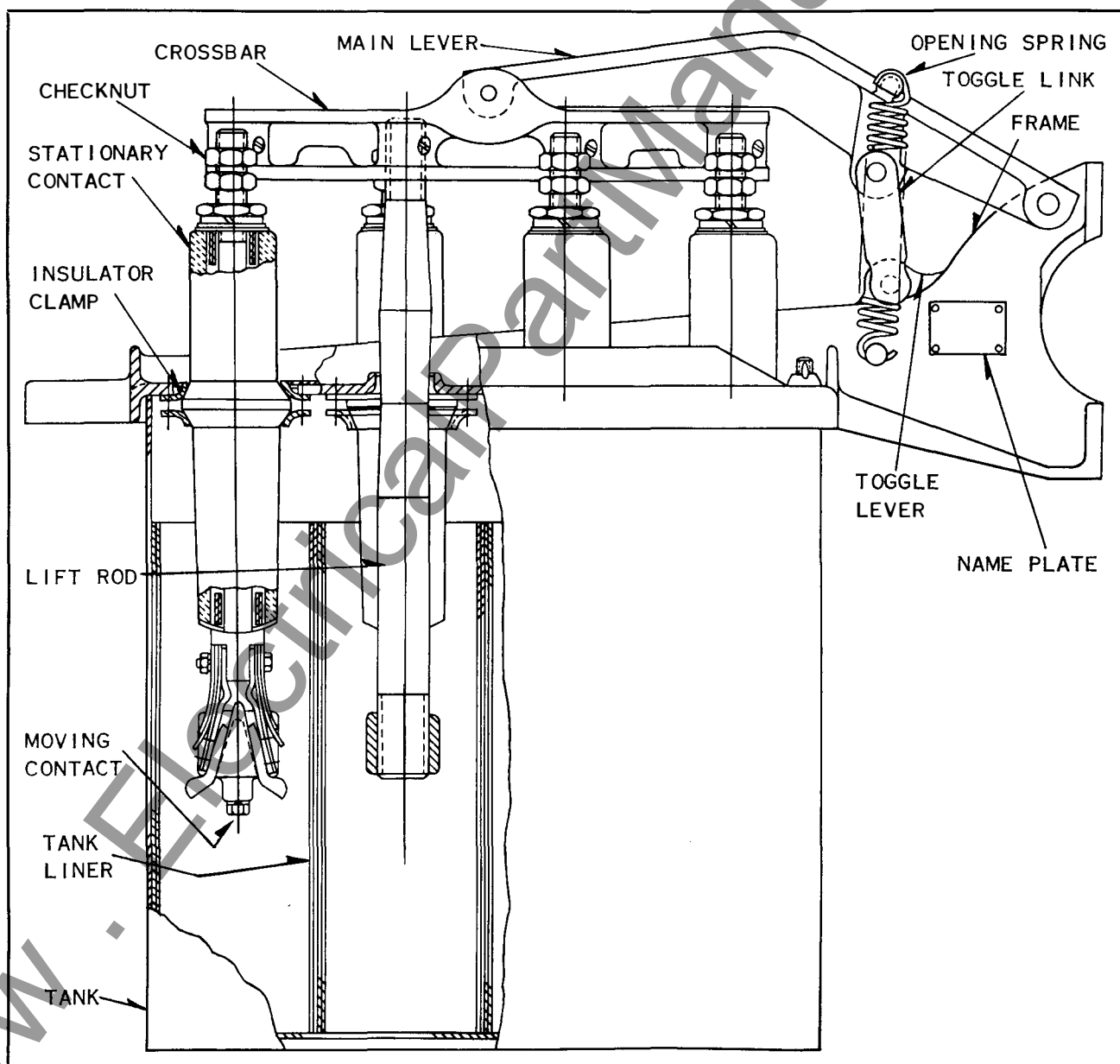

**FIG. 3. F-22 Single Throw Breaker Unit**

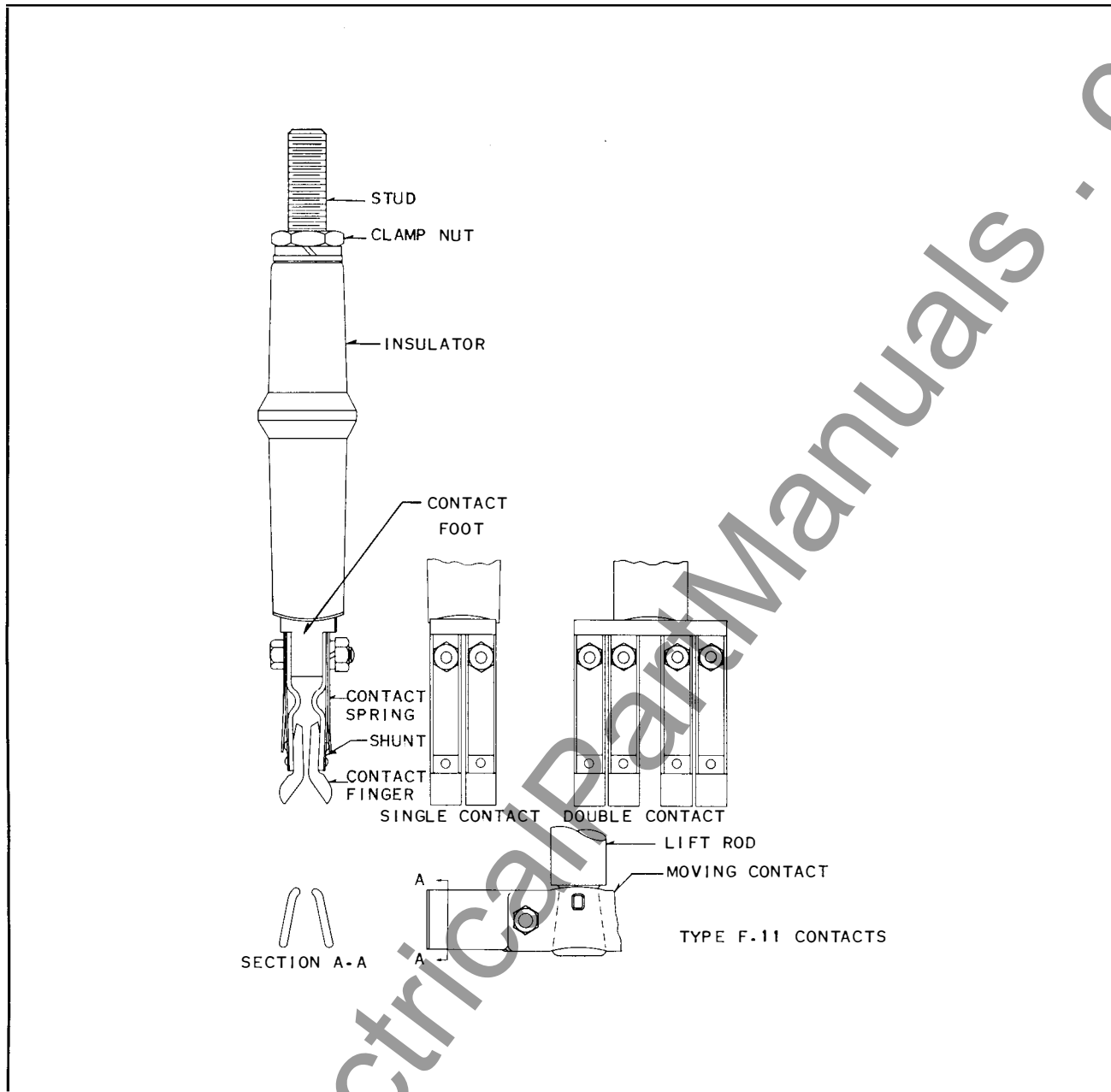

**FIG. 4. Contacts F-11**

be placed on the ceiling of the floor below they should be reassembled as shown in Fig. 10. The operating rods are  $\frac{3}{4}$  pipe with a taper thread on one end and a straight thread on the end used for adjusting. Be sure and assemble pipe nut on this end to lock adjustment when complete.

**9.** Connect power circuit. Be sure conductors of adequate cross section are used to carry the

expected load in the circuit without overheating. Be sure all surfaces are clean before bolting together. A light coat of linseed oil, particularly on threaded studs, will help make up a tight, low resistance joint and will make breaking the joint easier. Be careful when bolting on circuit copper that alignment of contacts is not disturbed.

**10.** Connect up accessories and attachments according to detail diagrams.

# ADJUSTMENT

Connect the coverplate to the breaker units. Adjust the length of the rod so that with the coverplate in the latched position the toggle on the breaker unit is within approximately  $\frac{1}{16}$  inch of its stop. On remote control breakers the length of rods should be adjusted so each bell crank travels an equal distance each side of centerline, i.e., with coverplate and breaker unit in mid position each bell crank should be approximately right angles to pipe. Be sure to lock adjustments with pipe nuts when adjustments are completed.

Check to see that, with handle in open position there is some clearance left between trip lever and top of slot in the coverplate and that the breaker unit linkage is resting on the open position stop.

Check to see that with coverplate in the closed position contacts are properly engaged.

The length of the lift rods in the Type F-11 breaker is fixed. The cross bar clamps to the upper end, the moving contacts clamp to the lower end. An indent in each end presses into the wood and prevents rotation. In replacing rods squeeze the indent into the wood by clamping in a vise or with a "C" clamp. Tightening the bolts alone does not provide the necessary pressure.

The lift rods in the Type F-22 breakers are threaded on both ends. The proper adjustment is secured when the contacts are at the proper closed position with the toggle stop in the linkage in contact. A wood screw prevents rotation. In replacing rods be sure there are no burrs in the threaded holes and drill a hole in the wood rod to start the locking screw.

Check operation when the breaker is closed suddenly and when trigger is released with breaker in the closed position. Check to see that moving contacts enter approximately centrally between the fingers when closing and that the arcing contacts engage first and break last.

Check to see that trigger releases trip lever if it is raised slowly to full travel. Use only graphite type lubricant such as used for locks or guns on the trigger roller.

Raise trip core of each trip device and check to see that trigger is released with approximately  $\frac{1}{16}$  inch of travel left. Check to see that with trip rod in contact with trigger applying minimum rated cur-

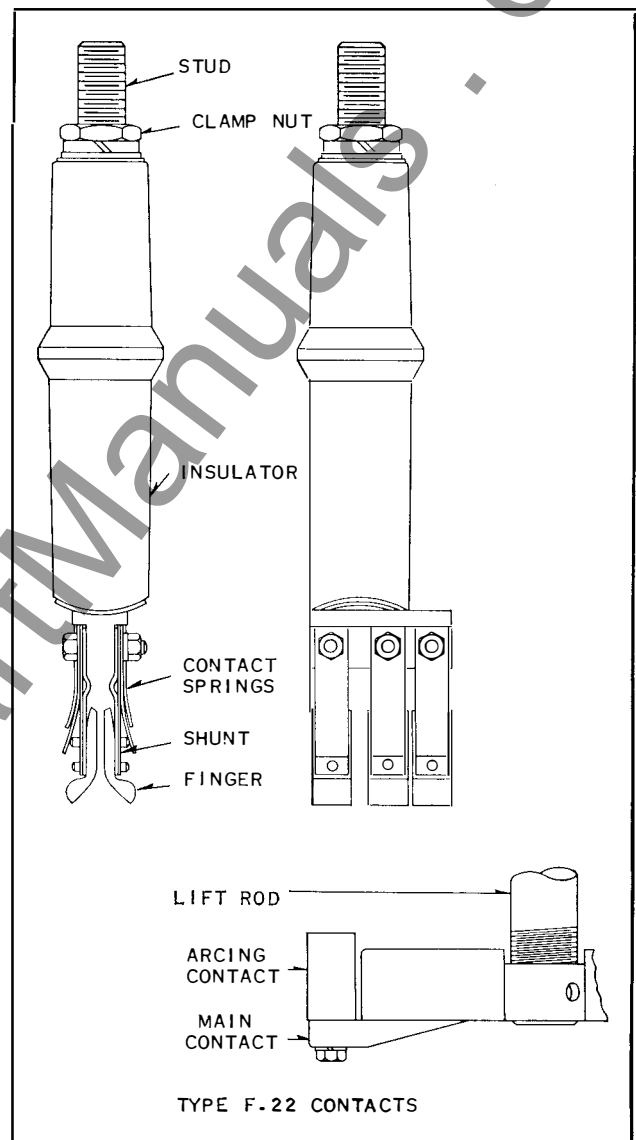

FIG. 5. Contacts F-22

rent to the trip coil or 80% of normal voltage to a shunt trip coil will release trigger.

Check undervoltage to see that applying 80% of normal voltage picks up the armature from the retrieved position. Check to see that armature will drop from closed position when voltage falls to about 50% of normal, check to see that releasing the armature slowly by hand still releases trigger without stalling.

Light out each contact of auxiliary switch in bell alarm.

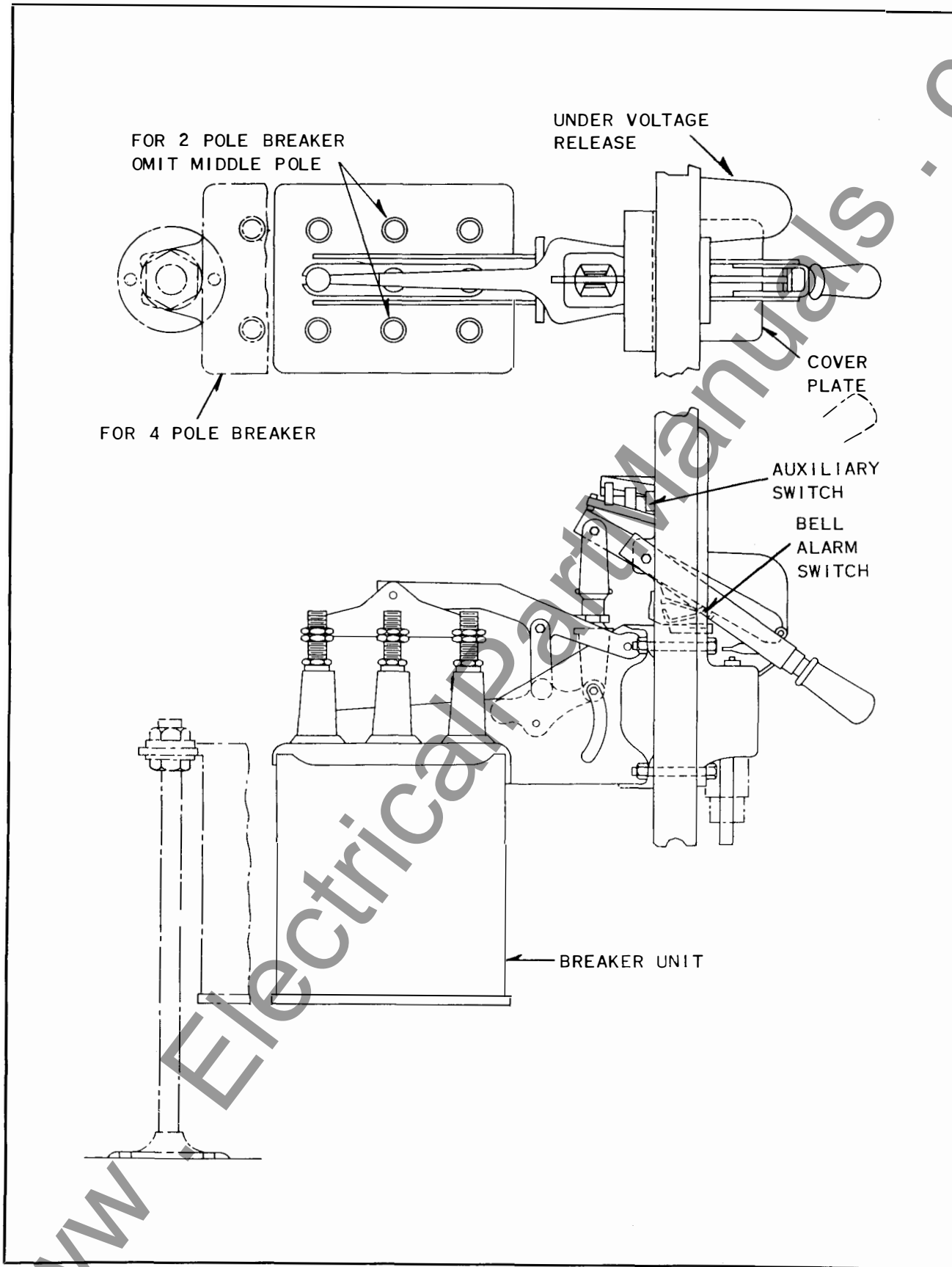

FIG. 6. Switchboard Mounting Assembly

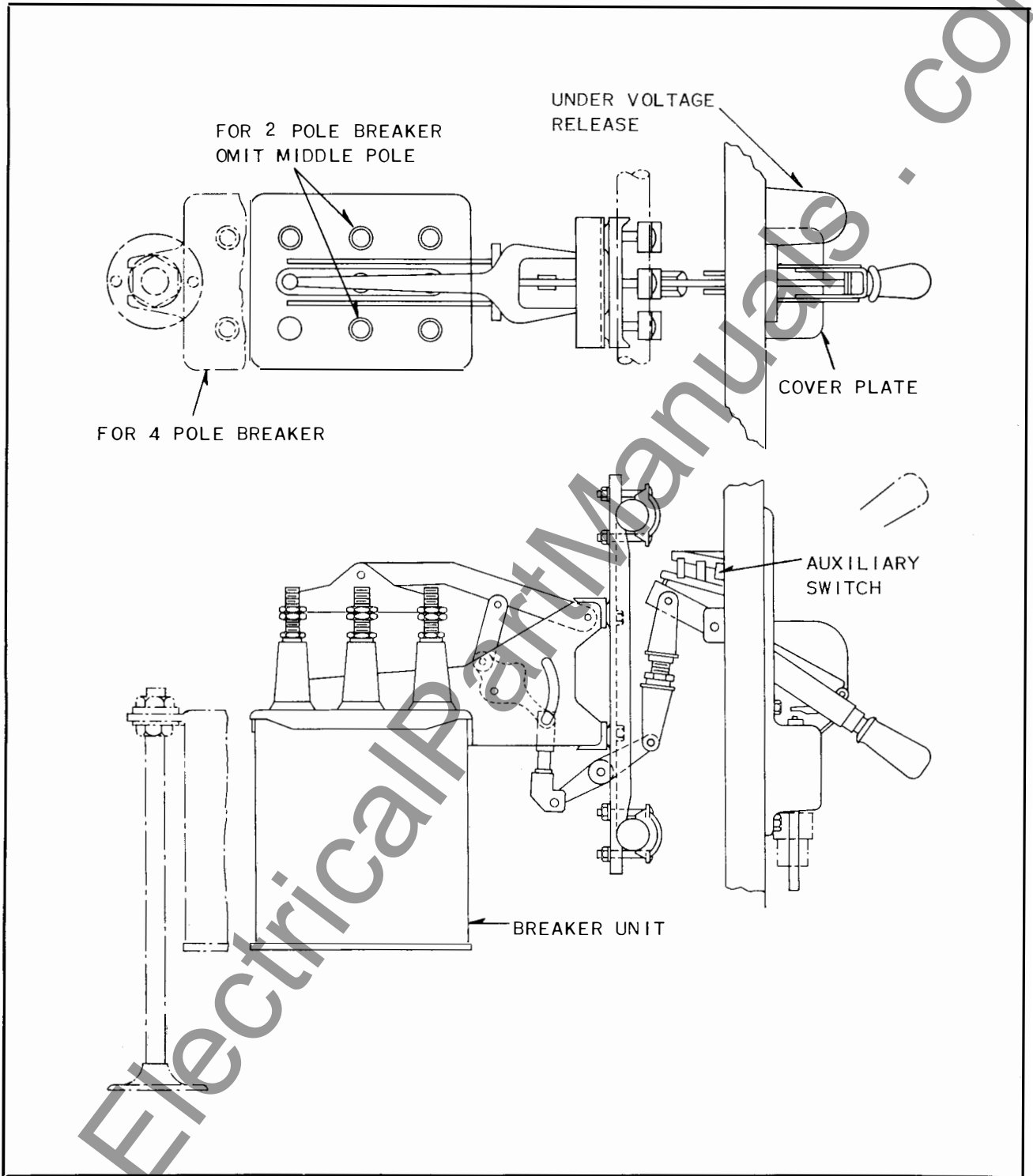

FIG. 7. Panel Frame Mounting Assembly

Check to see that main copper connections are tight and taped according to standard practice.

Check to see that tank is filled to proper level with oil that has been checked to be up to standard.

New oil should check 22 kv or better in standard test cup. Be sure dash pot of time delay trip is filled with the special oil provided.

# MAINTENANCE

Examine the breaker from time to time, the frequency of the inspections to depend on the conditions under which breaker operates. See that it is

clean, that all cotter pins are in place and no bolts loose. See that no levers or links are worn so much at fulcrums as to interfere with operation of breaker.

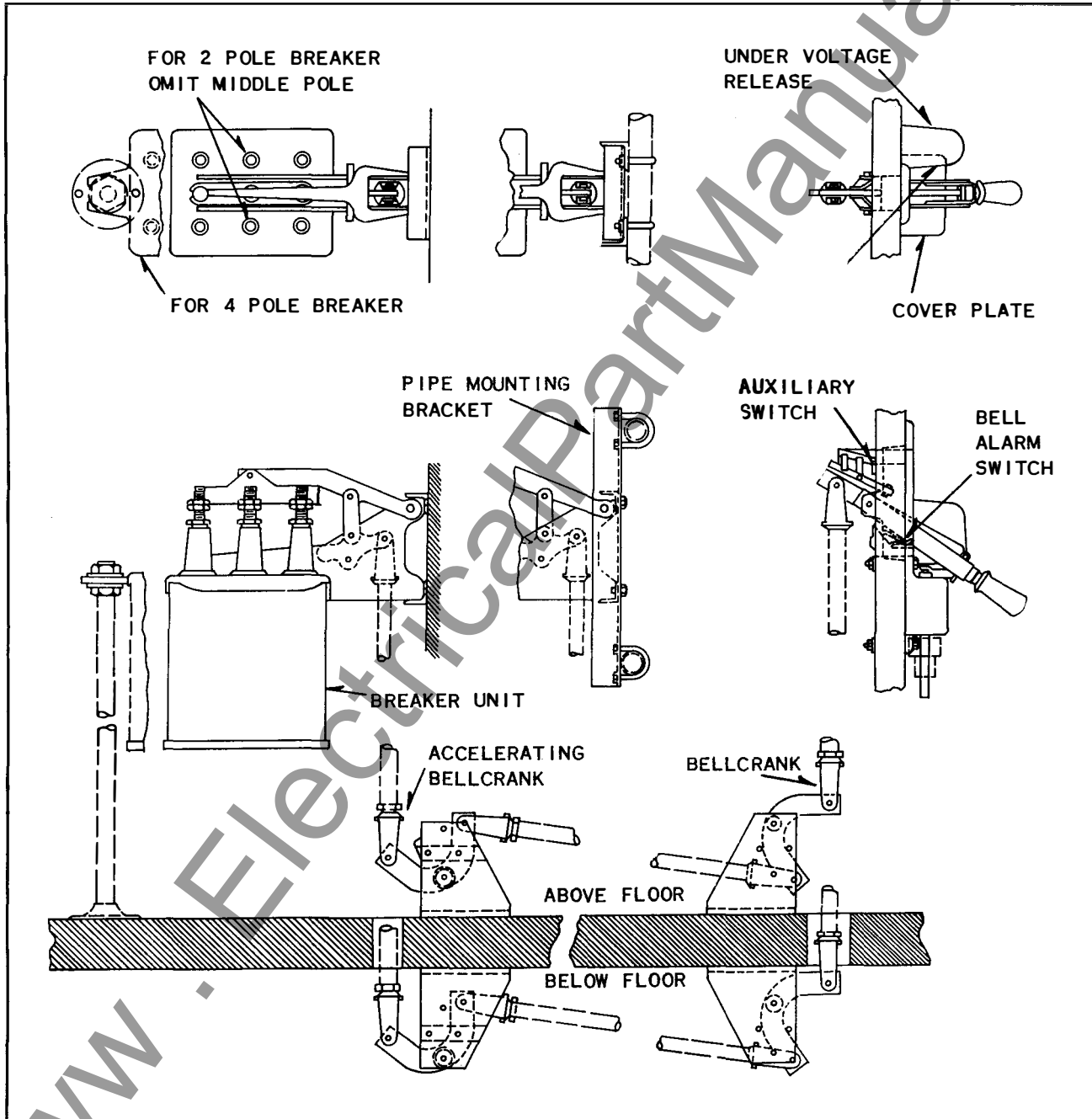

FIG. 8. Remote Control Assembly

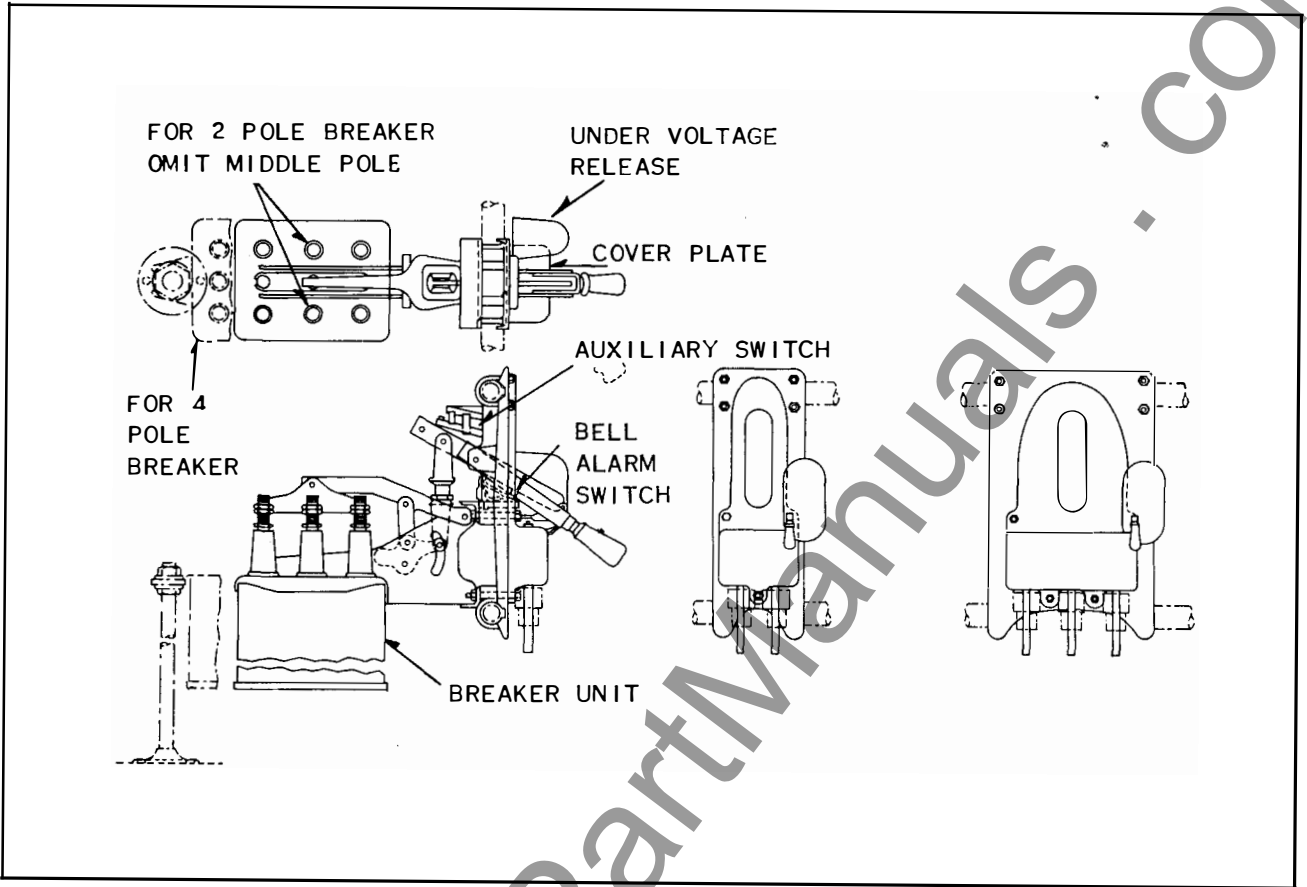

FIG. 9. Pipe Frame Mounting Assembly

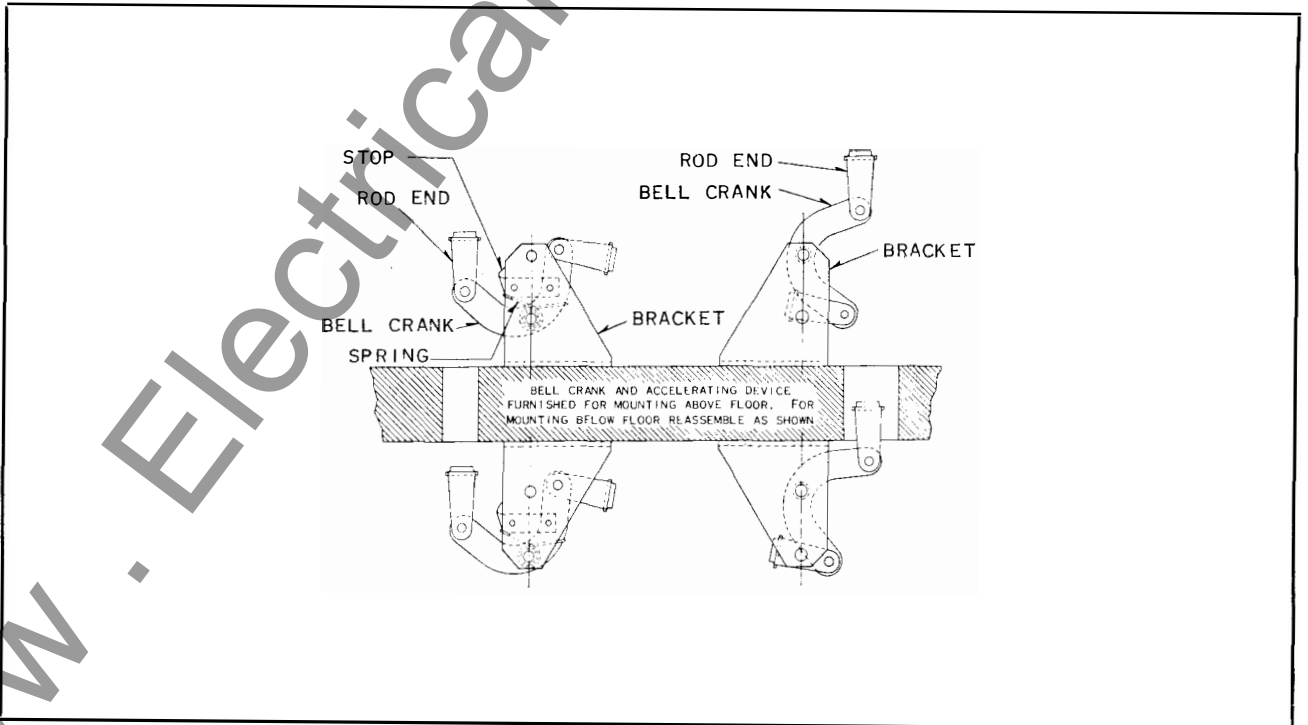

FIG. 10. Bell Crank Assembly

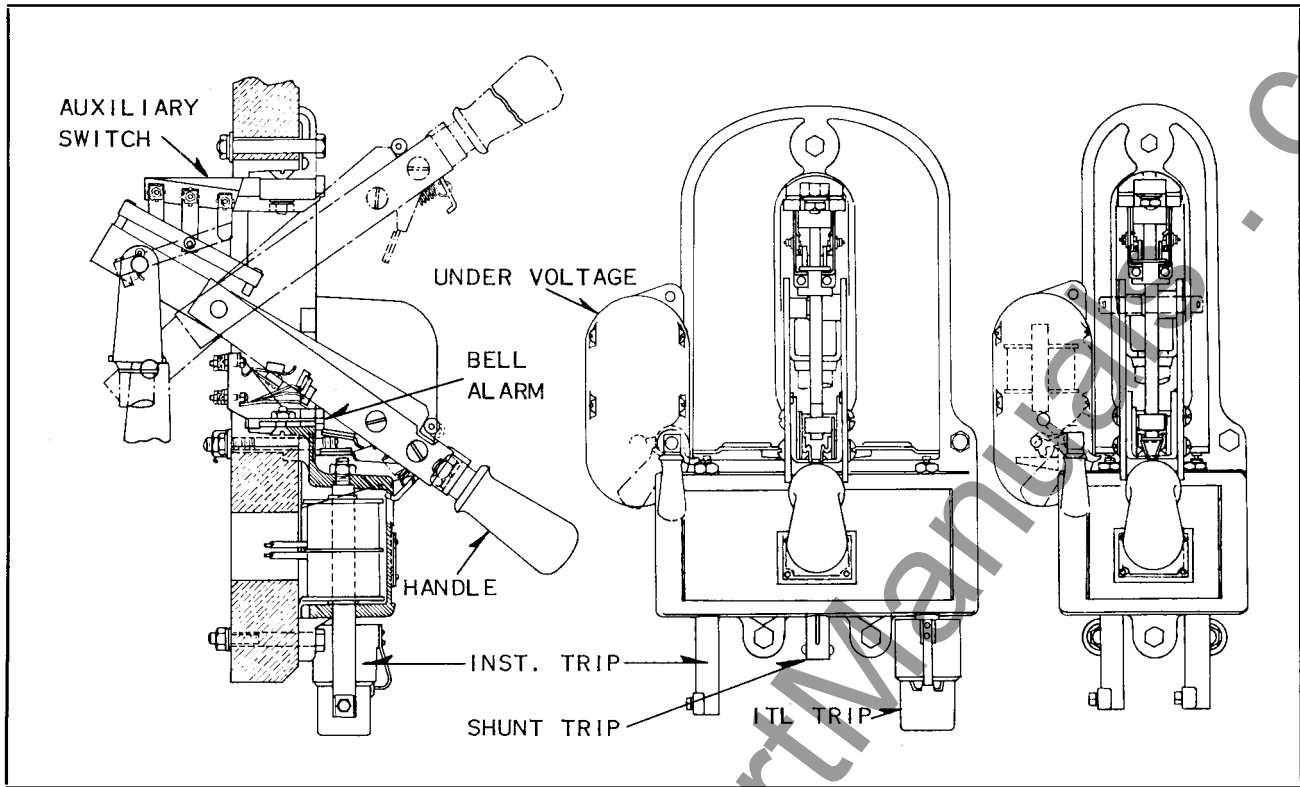

FIG. 11. Single Handle Coverplate

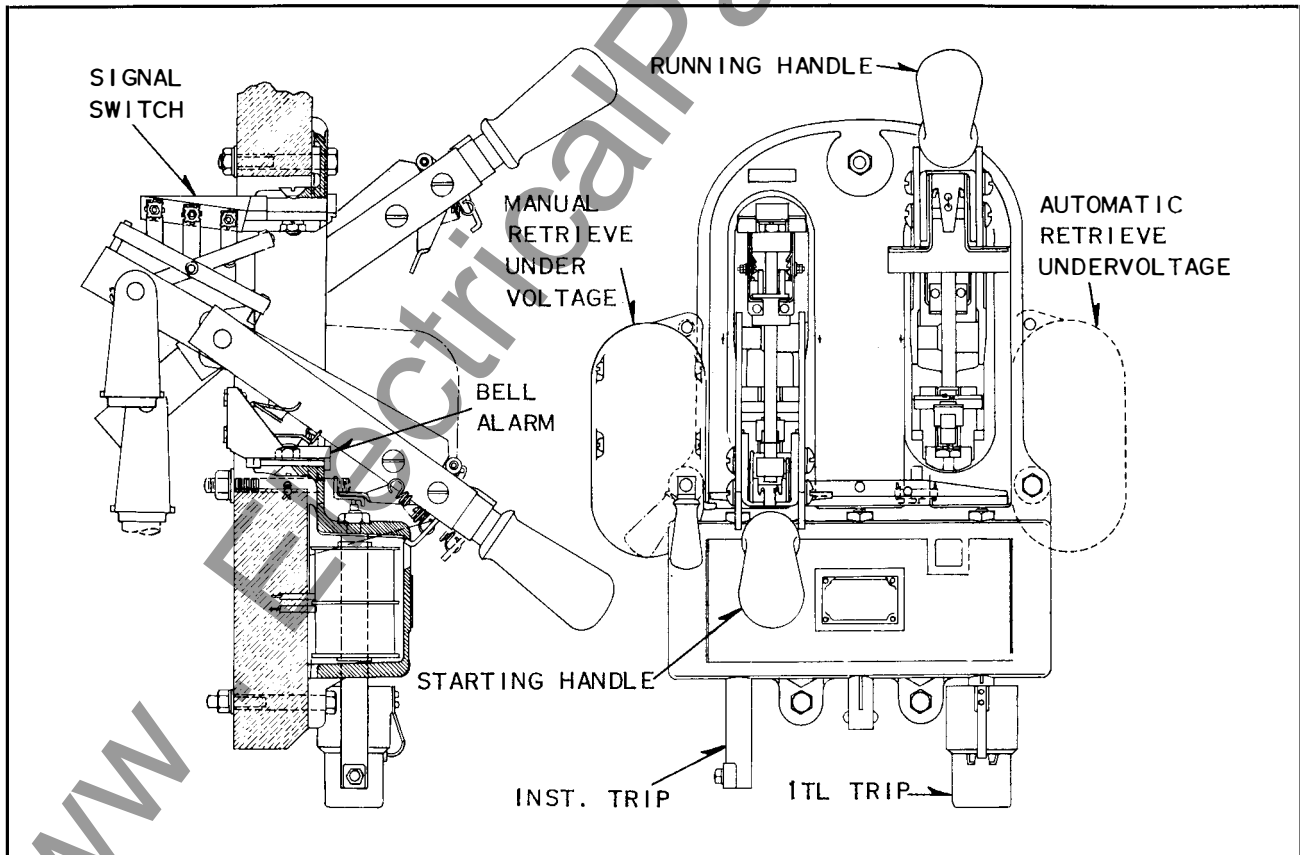

FIG. 12. Double Handle Coverplate

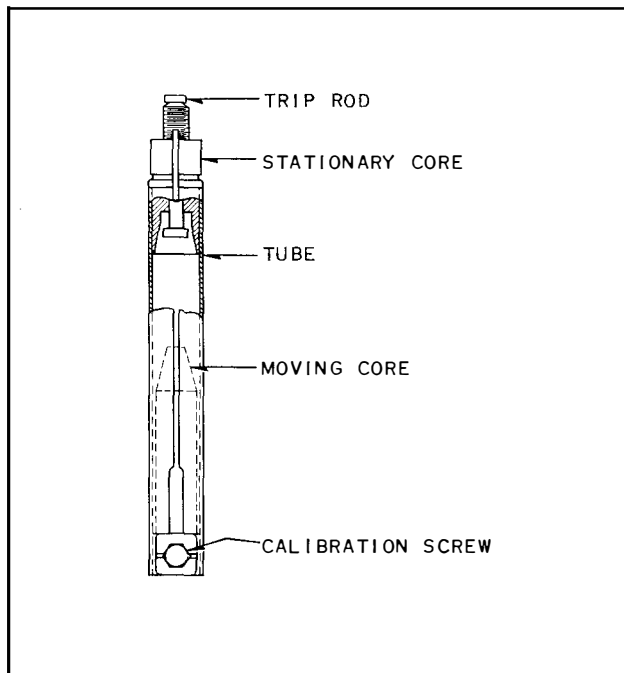

FIG. 13. Instantaneous Overload Trip

Drop tank and examine the contacts. Remove any slight burns with a file. Replace contacts when burns penetrate more than  $\frac{1}{16}$  inch. On the Type F-11 breaker, burning will be on the top of the moving contact and on the flared portion of the finger. Contacts need be replaced only when burned so badly as to cause possible stubbing before the next inspection.

Give the moving contacts a light rubbing with fine sand paper (not emery cloth). Place the sand paper over moving contact with the sand side out and close the breaker three or four times.

Check the insulating quality of the oil. If it tests below 17 kv in a standard test cup replace it. When replacing oil be sure to clean out the tank before refilling. When a portable test set is not available it is common practice to replace the oil with new oil and then take the original oil to the test set, filtering if necessary before re-using. Note oil need not be replaced just because it is darkened by suspended carbon. Depend on the test cup test.

Check the tank liners to see that they are not burned so deeply that there is danger of burning through before the next inspection.

When replacing the tank be sure it is centered and draw up all bolts evenly and tightly.

**ATTACHMENTS**

The instantaneous overload trip shown in Fig. 13 consists of trip coil and trip details to assemble in

the coverplate. The distance between the moving and stationary cores can be varied as indicated by the calibration marking for tripping between 5 and 9 amperes in the trip coil. By using current transformers of suitable ratio tripping can be accomplished at any desired primary current. In assembling be sure that the wedges are put in below the coils. Also check to see that the trigger is released when the moving tripping core is raised slowly mechanically to within  $\frac{1}{16}$  inch of its total travel. Also check to see that tripping occurs if moving core is raised mechanically until trip rod touches trigger and 5 amperes applied suddenly to coil.

The shunt trip attachment for tripping from a separate source of power as shown in Fig. 14 is essentially a non adjustable overload trip. Tripping should occur if moving core is raised slowly the same as on the overload trip. The coil should pick up and trip the breaker if 60% voltage is applied. If moving core is raised to bring trip rod in contact with trigger, tripping should occur if full voltage is applied to coil. If tripping is actuated by a relay an auxiliary switch is to be used to interrupt coil circuit to save relay contacts.

Time delay overload trip as shown in Fig. 15 is similar to the instantaneous trip with a dash pot added to the moving core to hold it back. The time delay can be changed by rotating the partial disk on the lower end of the trip rod so as to change the number of the holes uncovered. A loose washer provides for quick resetting. Current calibration is obtained by screwing pot into or out of the dashpot cover.

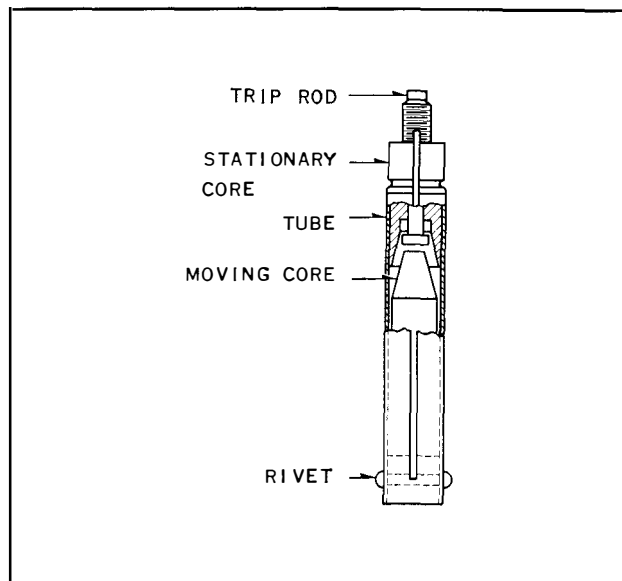
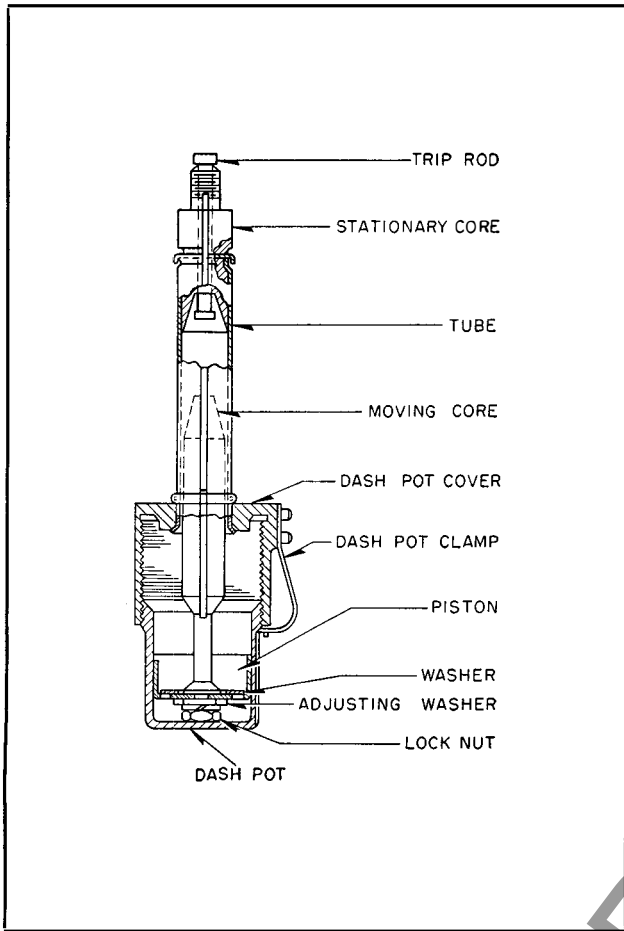
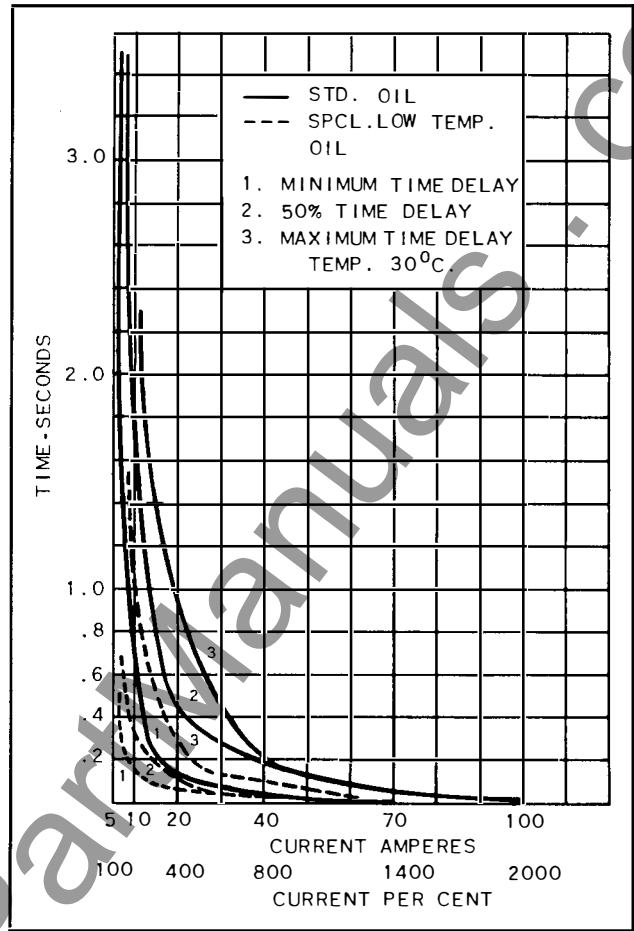

FIG. 14. Shunt Trip



**FIG. 15. Inverse Time Delay Trip**



**FIG. 16. Inverse Time Delay Tripping Curves**

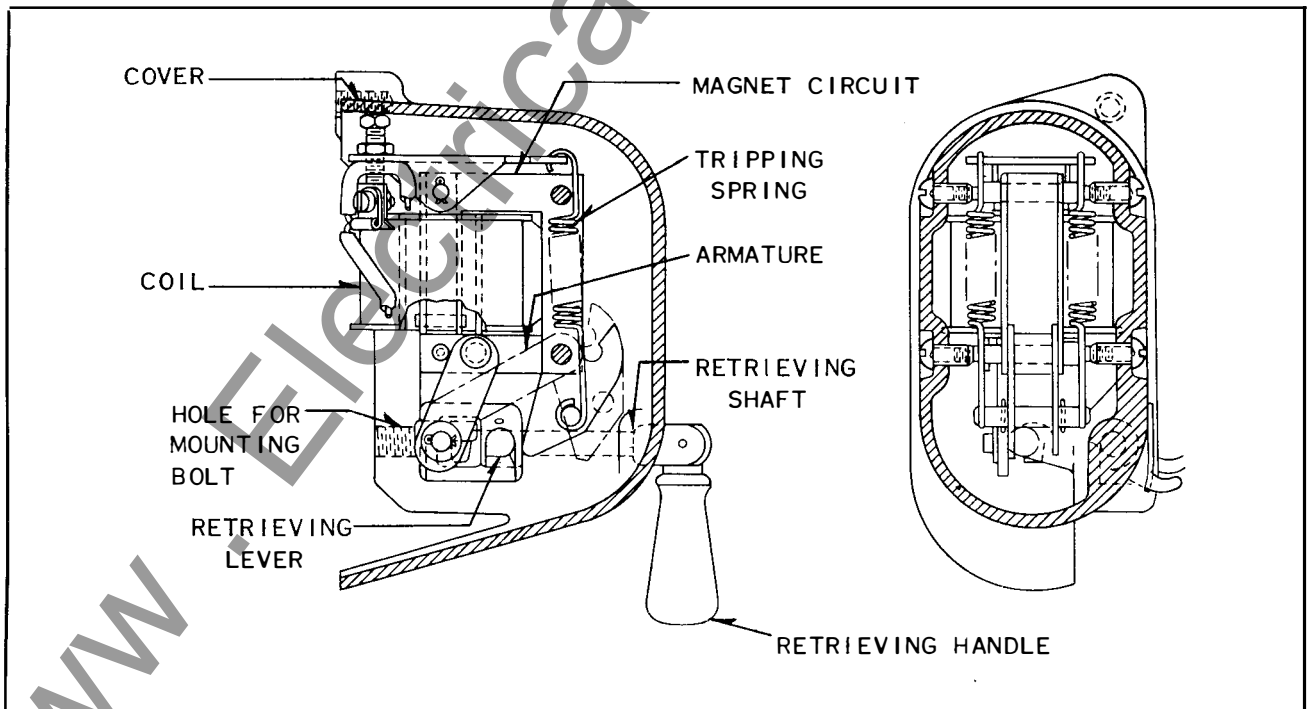

**FIG. 17. Hand Retrieve Undervoltage Trip**

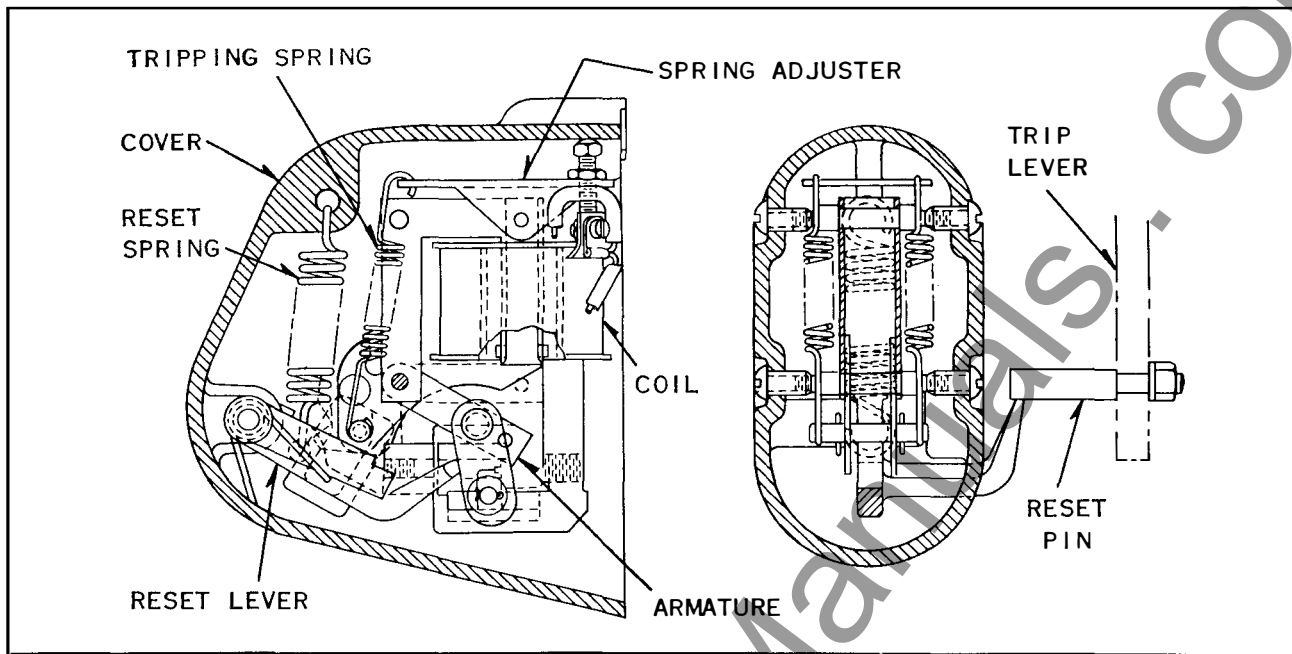

FIG. 17A. Automatic Retrieve Undervoltage Trip

The viscosity of the oil affects the time delay. The temperature of the oil affects its viscosity. The time delay also varies inversely with the size of the overload. Hence, this device cannot be used to obtain a definite time delay. Overloads persisting for a short time such as occur when starting a motor will not trip the breaker. If the overload persists tripping will take place.

The hand retrieve undervoltage release is mounted on the left hand coverplate mounting bolt. It is necessary to remove the bolt and insert it from the rear screwing it into the tapped hole in the undervoltage cover. Check to see that with the handle rotated in a clockwise direction as far as it will go the application of 80% control voltage will hold armature. Check to see that, with handle released

slowly after removal of voltage, the trigger of coverplate is released. Check to see that armature will drop and trip breaker when voltage is reduced to approximately 50% of normal. Adjustment is provided to vary pull of spring to vary drop out voltage.

*This device must be used when coil is connected to load side of the breaker.*

The automatic retrieve undervoltage release is mounted on the right hand coverplate bolt. Check to see that when the breaker is open and the reset pin is clear of the reset lever that the reset spring brings the armature up so that 80% of normal voltage will hold armature. Check to see that when breaker is closed the reset pin forces the reset lever clear so armature can drop and release the

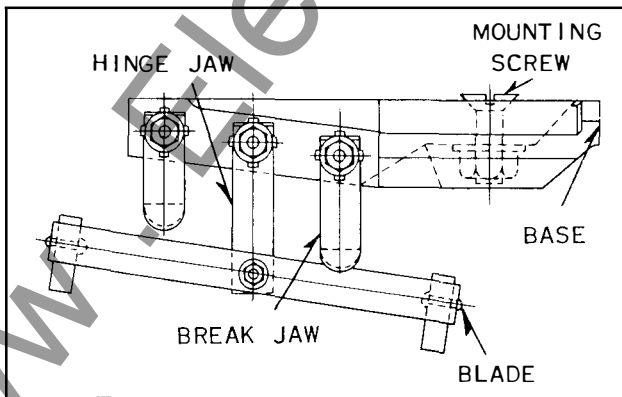

FIG. 18. Auxiliary Switch

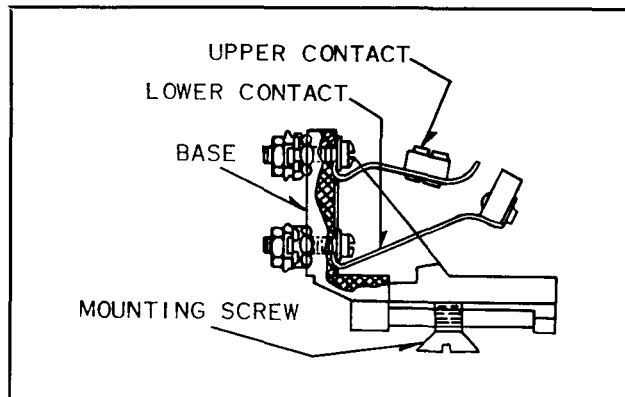

FIG. 19. Bell Alarm Switch

## MAINTENANCE

coverplate trigger. Check to see that reducing the voltage to approximately 50% of normal releases the armature. ***This device must be used when coil is connected to line side of breaker.***

A separate transformer rectifier device is used to supply d-c to the standard device see I.C. 2634 for detail instructions. When a delay in the tripping is desired a separate transformer rectifier-capacitor device is used. See I.C. 2635 for detail instructions.

A two-pole double throw auxiliary switch is shown in Fig. 18. The operation of the trip lever to which the breaker is attached throws the switch from one position to the other. Check from time to time to see

that the contacts are clean and that the connections are tight.

The mechanical interlock, shown in Fig. 20, consists of a bar and centralizing springs so arranged that it is possible to close but one of two levers at a time. This may be used on two single handle coverplates on various center lines or on the two handles of a double handle coverplate. Its chief application is a double-throw breaker made of two single-throw units operated from two handles of the coverplate. The double-throw F-11 breaker has an equivalent interlock which is an integral part of the breaker unit.

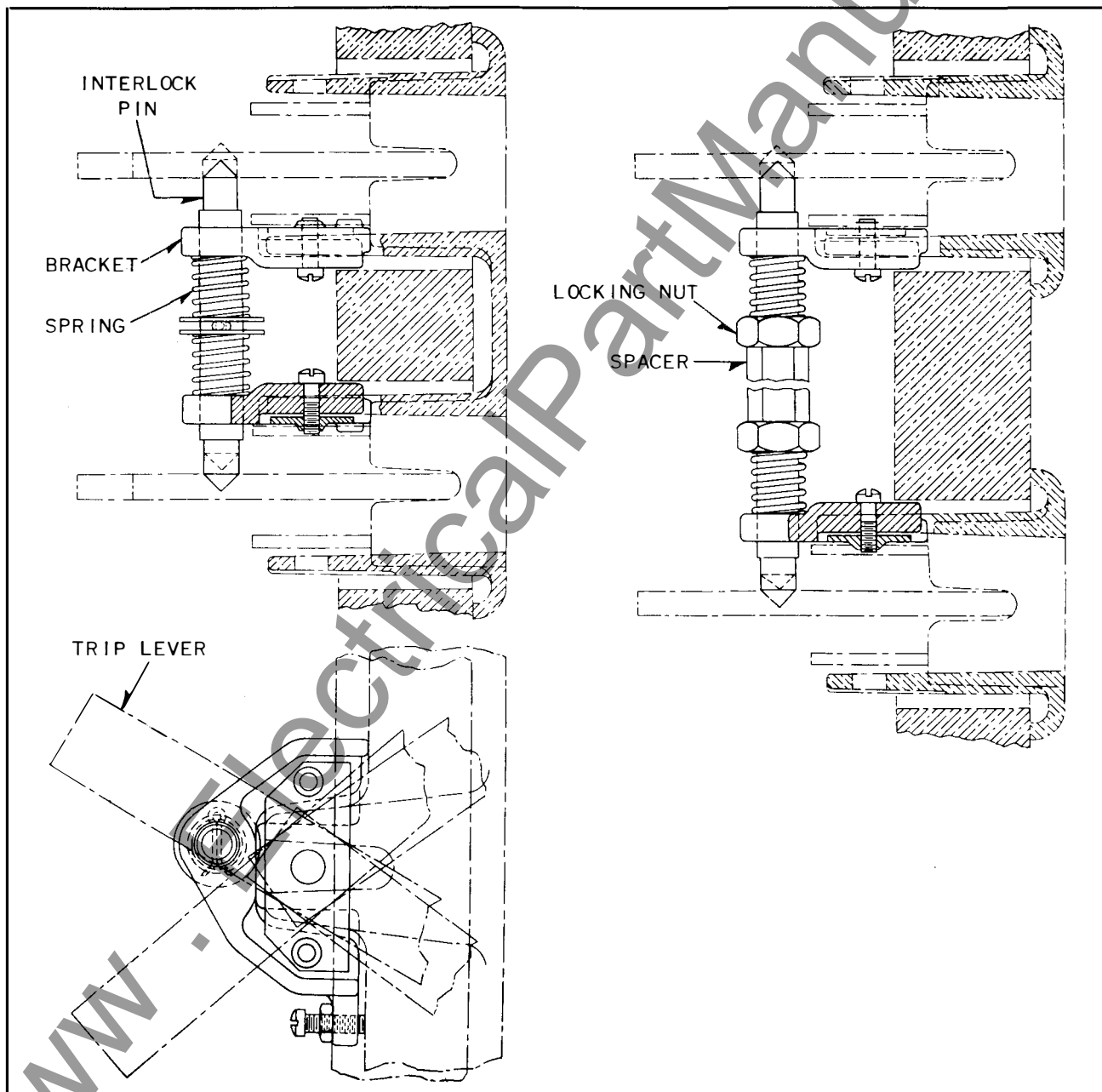

FIG. 20. Double Throw Interlock

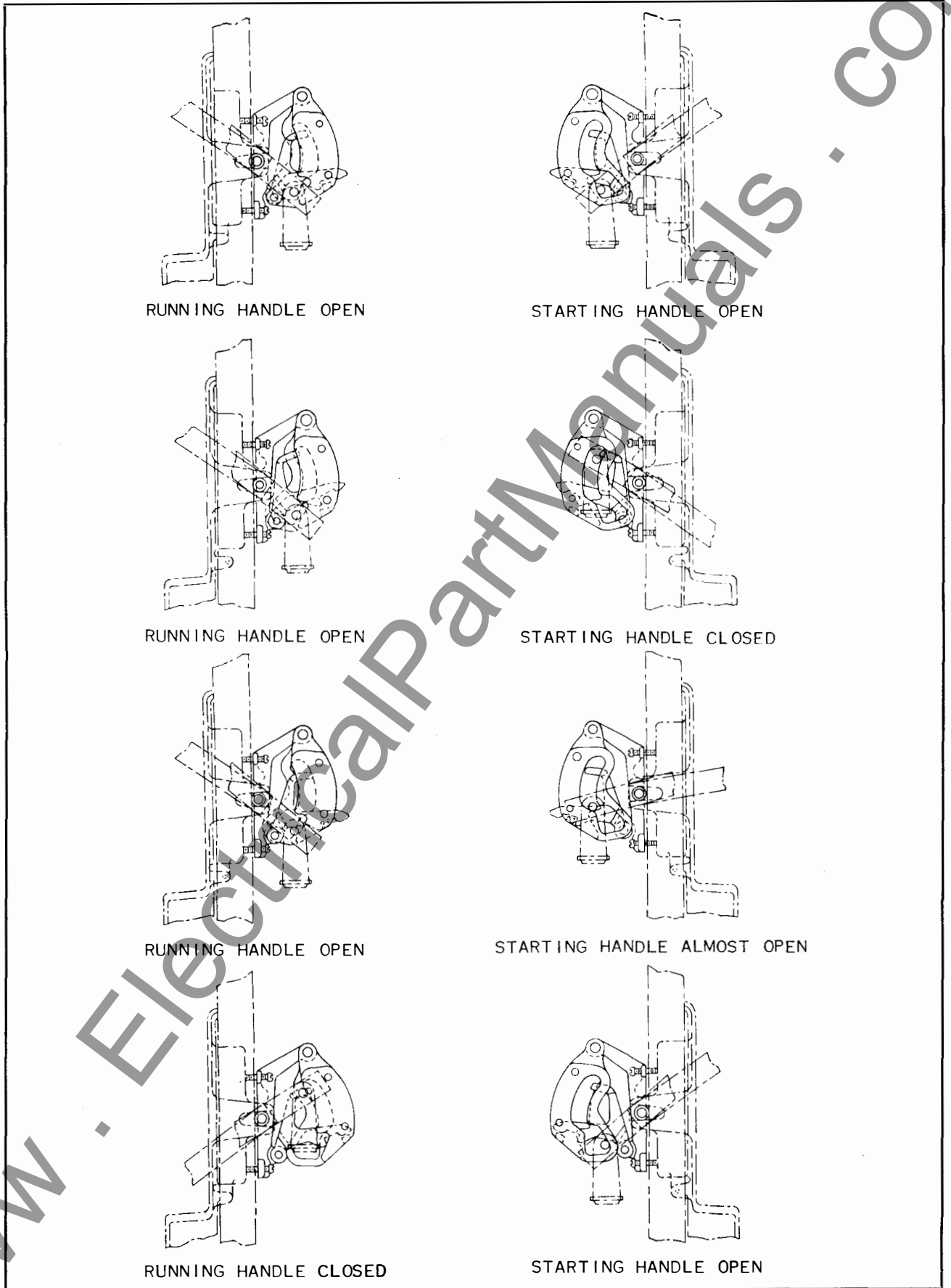

FIG. 21. Sequence Interlock

## MAINTENANCE

The sequence interlock shown in Fig. 21, compels the complete closing and complete opening of the handle to which the starting breaker is attached before the running breaker handle can be moved to the closed position. With both handles in the open position the running handle is locked in that position by the shoulder on the interlocking casting. When the starting handle reaches the closed position the pin in the handle pushes the upper arm of the unlocking lever upward so the lower locking portion releases the interlocking lever which then swings towards the panel. As the starting lever returns to the open position, the pin strikes the unlock-

ing surface of the interlocking lever swinging it back away from the panel. This unlocks the running handle which can be moved to the closed position if done promptly before the interlocking lever swings back into the locking position. If the running handle is moved to the closed position the interlocking lever is held out away from the panel thus locking the starting handle in the open position.

The hardware furnished is sufficient to mount any of the standard breaker assemblies. The table, Fig. 22, gives the exact hardware for any particular assembly. The balance left over should be discarded.



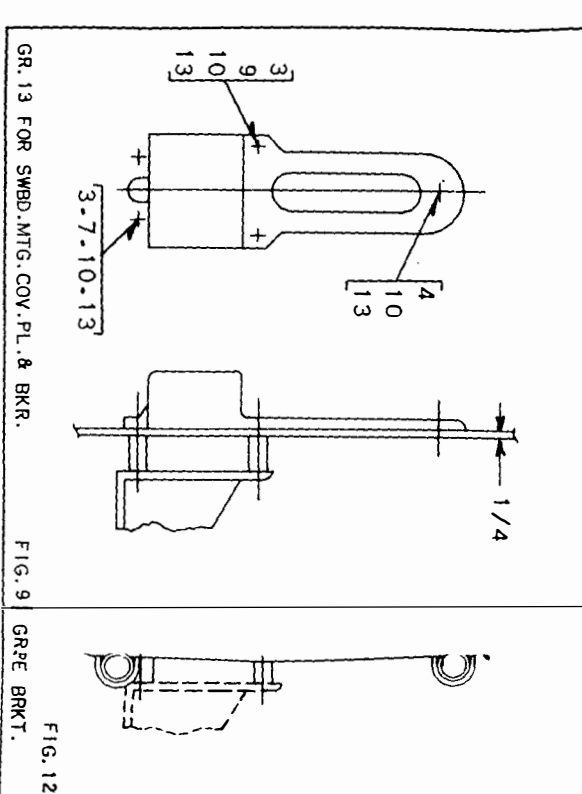
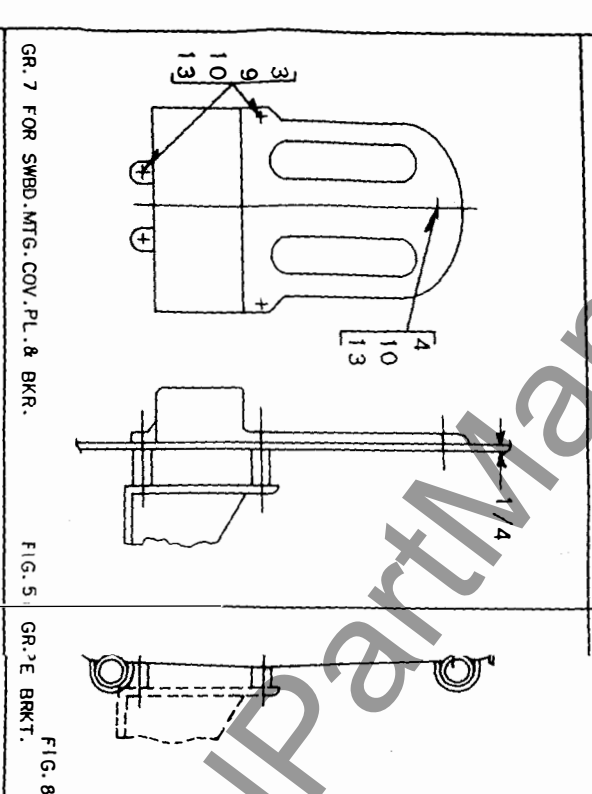
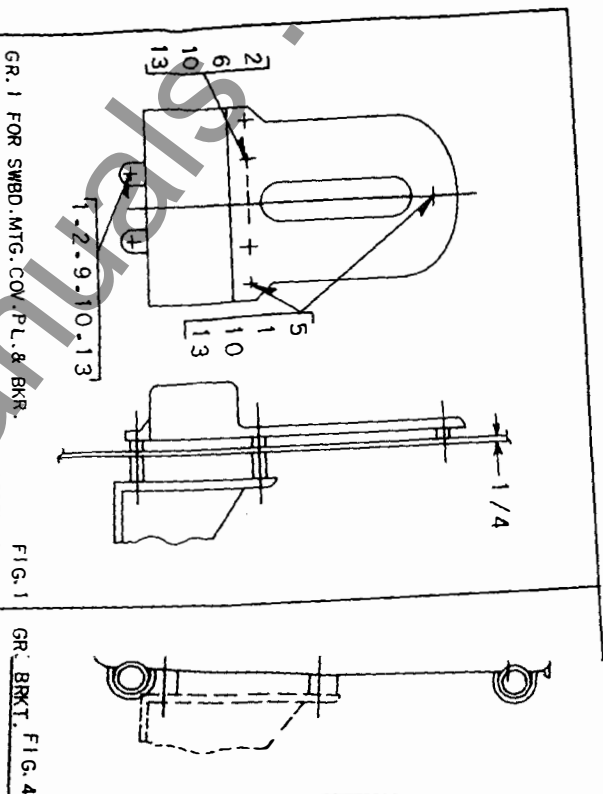

ITEM	DESCRIPTION	GROUP NUMBER																	
		1	2	3	4	5	6	7	8	9	10	11	12	13	14	15	16	17	18
1	SPACER S-869275 (1/2)	5																	
2	SPACER S-898819 (1-1/2)	4																	
3	SPACER S-1575161 (1 1/2)																		
4	3/8 - 16 x 1-1/4 HEX STL BOLT	3			1	1	1	3				1	1	1	3			1	1
5	3/8 - 16 x 1-3/4 HEX STL BOLT	3																	
6	3/8 - 16 x 2-1/2 HEX STL BOLT	2		2															
7	3/8 - 16 x 3 IN. HEX STL BOLT			3	3	4			1	3		2	2		1	3		2	
8	3/8 - 16 x 3-1/4 HEX STL BOLT																		
9	3/8 - 16 x 3-1/2 HEX STL BOLT	2		2		4	4	4	4		4		2		2		4		
10	3/8 - 16 HEX STL NUT	7	3	7	3	5	5	5	3	5	3	5	3	5	3	5	3	5	3
11	3/8 STD STL WASHER			5	3				1	3					3	3			
12	3/8 x WIDE STL WASHER											2							2
13	3/8 STL LOCKWASHER	7	3	7	3	5	5	5	3	5	3	5	3	5	3	5	3	5	3

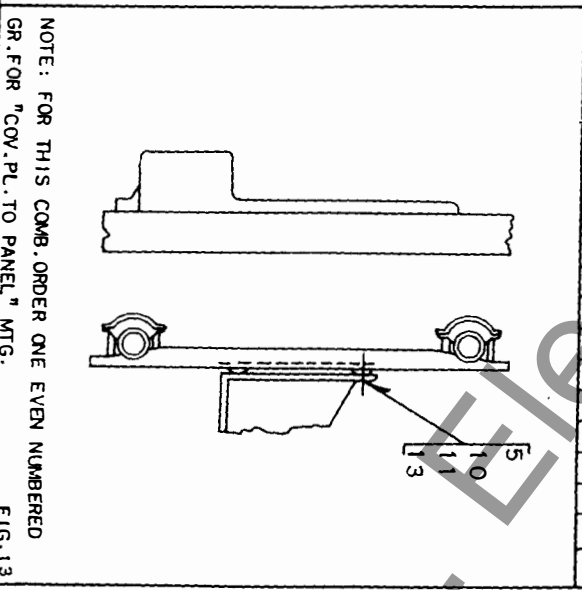

NOTE: FOR THIS COMB. ORDER ONE EVEN NUMBERED GR. FOR "COV.PL. TO PANEL" MTG.

FIG. 22. Mounting Assembly

[www.ElectricalPartManuals.com](http://www.ElectricalPartManuals.com)

