

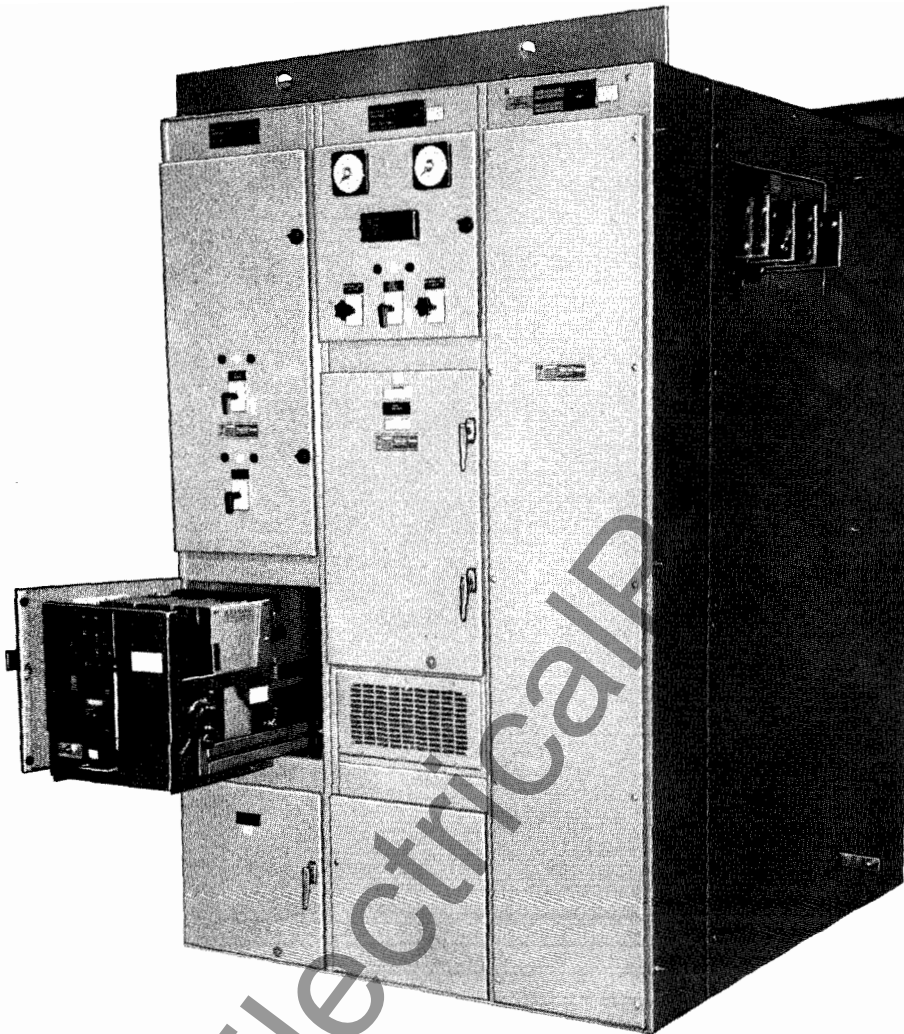

December, 1988
Supersedes Renewal Parts Data 33-790-1F,
pages 1-20, dated December, 1987
Supplements I.B. 33-790-1F

Low-Voltage Power Circuit Breakers and Cell Parts Types DS and DSL



This publication covers the following breakers.

Breaker Type	Frame Size Amperes
DS-206	800
DSL-206	800
DS-206S	800
DS-416	1600
DSL-416	1600
DS-416S	1600
DS-420	2000
DS-632	3200
DS-840	4000

INDEX

Subject	Page Number
General Information	2
Common Parts	3
Pole Units	4-7
Arc Chutes & Barriers	8
Levering Mechanism	9
Operating Mechanism	10-12
and Related Parts	
Automatic Tripping System	13
Optional Accessories	14-15
DSL-206 and DSL-416	16
Feeder Circuit	17
Instrumentation	
Breaker Interference	18
Brackets	
Assembly Cell Parts	19

Parts Identification

Renewal Parts Data 33-790-1F is supplementary information to Instruction Book 33-790-1F, *Instructions for Low Voltage Power Circuit Breakers Types DS and DSL*. The illustrations in this Renewal Parts Data show parts and sub-assemblies which are identified by name and style number in the associated tabulations. Additional information and illustrations are shown in the figures in I.B. 33-790-1E, which show many sub-assemblies and detail parts in order to illustrate their function and location in the assembly. Some of the detail parts shown in the instruction book are recommended only as part of a sub-assembly to facilitate their replacement or installation in the field. The availability of parts and subassemblies is indicated by style number in the following data.

If the item in question cannot be identified by style number, refer to the Figure number, name and item number as shown in this RPD (or I.B. 33-790-1F) along with the breaker type and its shop order number or style number as shown on the nameplate on the front cover of the circuit breaker.

The above nameplate information will also be required when adding components, which are not direct replacements, to a circuit breaker.

It is not recommended that any field modification be attempted to change type DS manually operated breaker to an electrically operated breaker or any DS breaker to a DSL type.

RECOMMENDED SPARE PARTS

Spare parts recommended for stocking are indicated in the following data by the symbol ®. An adequate stock of spare parts will help minimize emergency situations and can substantially reduce production down time.

The amount of investment to be made in spare parts stock can be dependent on a number of individual factors. The items recommended and the quantities specified below are intended as a guide.

For 1 to 5 Breakers—Items marked ® in sufficient quantity for one breaker.

For 6 to 10 Breakers—Items marked ® in sufficient quantity for two breakers.

Over 10 Breakers—One spare complete breaker, plus recommended spare parts for one breaker.

ORDERING INFORMATION

1. Name item and give its style number. Specify quantity desired.
2. State method of shipment desired.
3. Send all orders or correspondence to nearest Westinghouse Sales Office.

PRICING INFORMATION

All of the style numbers in this Renewal Parts Data book are listed in Price and Entry Guide 120 and Electronic AMS.

Items Common to All Breaker Types

AUXILIARY SWITCHES—FIGURE 28

Refer to Fig. 28 for available auxiliary switches for all breakers except those wired per diagrams figures 10D, 10E, 10F, and 10G, and those equipped with mechanical interlocks.

SECONDARY DISCONNECTING CONTACTS—FIGURE NO. 3

To replace an existing contact block, or adding a block to a breaker with an existing mounting frame, order S# 591C498G06.

When ordering or replacing a top existing disconnecting contact cover, order S# 503B569H01.

Breakers originally supplied without secondary contacts will require a mounting frame to add a contact block, (see Fig. 3). Order S# 591C498G07 which includes an 8 point block and mounting frame. For cell mounted secondary contacts (see Fig. 34), order S# 590C808G01, which includes an 8 point block, mounting and hardware.

TYPE DS CIRCUIT BREAKER FASTENER KIT

S# 3586A86G01 kit includes an assortment of retaining rings, truarc rings, "E" rings, and "X" washers in a plastic bag. Recommended spares:

one (1) kit for one (1) breaker, two (2) for 2 to 5 breakers, three (3) for 6 to 20 breakers, and four (4) for over 20 breakers.

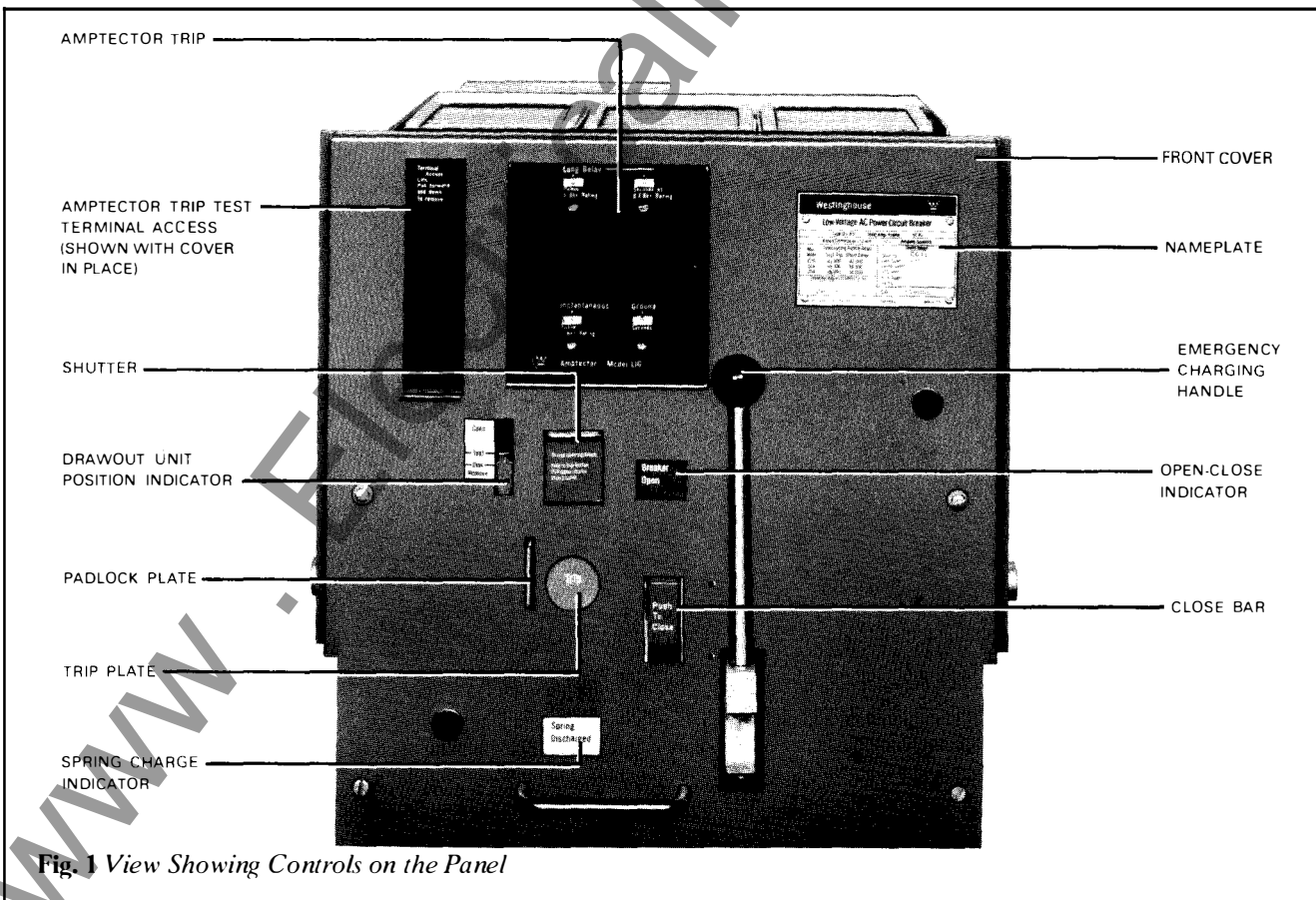

Fig. 1 View Showing Controls on the Panel

STANDARD HARDWARE

Standard hardware such as bolts, nuts, washers, etc. are not listed in this data. Such items should be purchased locally. **Note:** Bolts holding copper details together in the pole unit, and bolts holding levering in cranks should be SAE Grade 5.

BREAKER LIFTING YOKE

Breaker Type	Style No.	
	Hooks	Spreader Bar
DS-206, DSL-206	802B331G01	9561D78G01
DS-416, DSL-416	802B331G01	9561D78G01
DS-420	802B331G01	9561D78G01
DS-632	802B331G01	9561D78G01
DS-840	802B331G01	9561D78G02

BREAKER FRONT COVER

Breaker Type	Style No.
All DS except DS-632 and DS-840	567F498H01
DS-632	567F499H01
DS-840	567F503H01
All DSL except DSL-632 and DSL-840	567F498H02

DS BREAKER LABELS

Mechanism	Style No.
Breaker Closed/Breaker Open	3830A57H01
Spring Charged/Spring Discharged	3830A66H01
Trip Button Decal	3830A63H01

Levering in Device	Style No.
Levering Mech. Instruction	3830A56H01

Front Cover	Style No.
Conn/Test/Disc/Remove Decal	3830A67H01
Read Instruction Book Before Decal	3830A64H01

Front cover not supplied with Labels. Labels must be ordered separately

BREAKER ROLLERS (4 REQUIRED PER BREAKER)

S#503B565H01
 Note: Order Fastener Kit when ordering rollers.

LUBRICATION	Quantity	Use
S3701QB12J Moly Grease	14 oz. tube	for mechanical parts
53701AN00T Graphite Grease	Quart can	for contacts

VIDEO MAINTENANCE TAPES

- DS breaker maintenance and inspection tapes.
 VHS or Beta or 8mm
 Playing Time: 28 mins.
- Calibration and testing of Amptector overcurrent protection system. (VHS or Beta or 8mm)
 Playing Time: 31 mins.

VHS - 8187A14H01	VHS - 8187A14H04
Beta - 8187A14H02	Beta - 8187A14H05
8mm - 8187A14H03	8mm - 8187A14H06

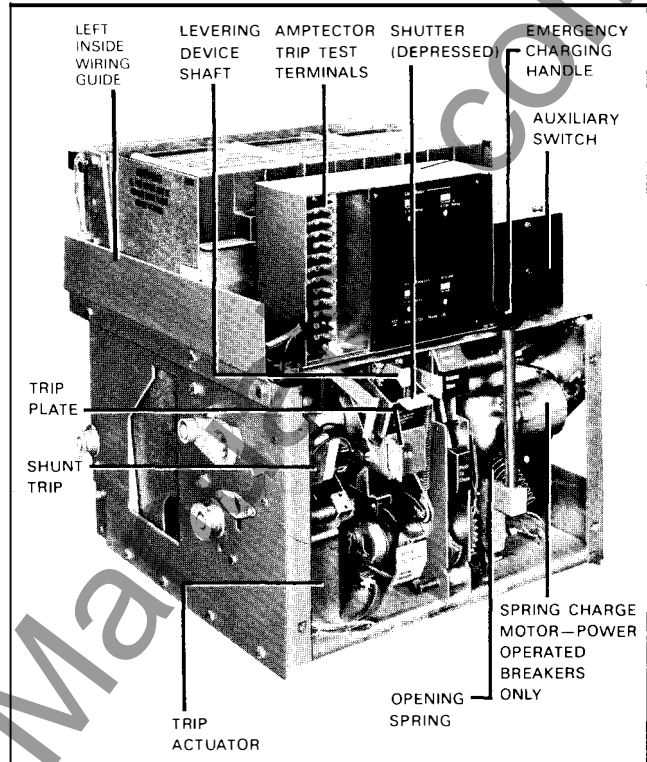

Fig. 2 DS 416 Breaker with Front Panel Removed

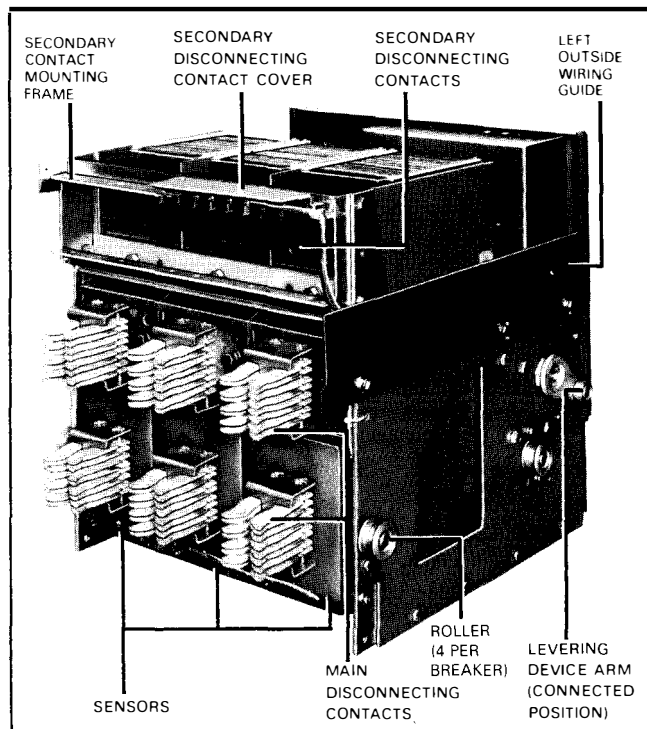

Fig. 3 Rear View Showing Levering Device Arm in CONNECT Position

Type DS-206, DSL-206 and DS-206S Pole Unit

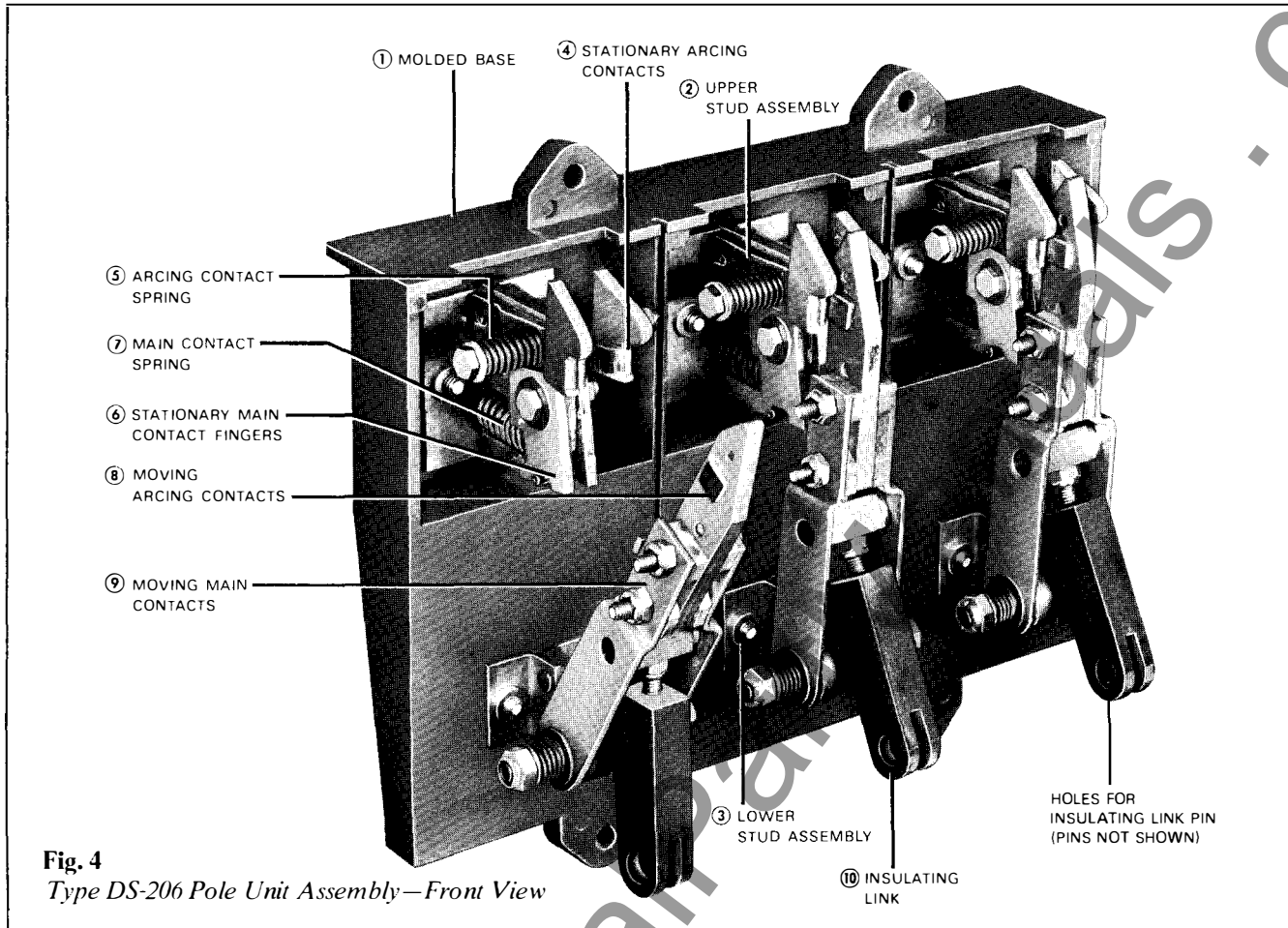

Fig. 4
Type DS-206 Pole Unit Assembly—Front View

Description	Fig. No.	Item No.	DS-206		DSL-206 ^①		DS-206S ^②	
			No. Req. Per Bkr.	Style Number	No. Req. Per Bkr.	Style Number	No. Req. Per Bkr.	Style Number
Three Pole Unit Assembly Complete	4	—	1	140D152G05	1	140D152G07	3	9145D41G02
Following are included in Three Pole Unit Assembly:								
Molded Base	4	1	1	140D150H01	1	140D150H01	3	553F204H01
Upper Stud Assembly	4	2	3	591C653G01	3	591C653G03	3	592C928G01
Lower Stud Assembly	4	3	3	591C652G01	3	591C652G03	3	592C927G01
Following are included in Upper Stud Assembly:								
Stationary Arcing Contact—R.H.	4	4	3 [Ⓡ]	682C829G01	3 [Ⓡ]	682C829G01	3 [Ⓡ]	682C829G01
Stationary Arcing Contact—L.H.	4	4	3 [Ⓡ]	682C829G02	3 [Ⓡ]	682C829G02	3 [Ⓡ]	682C829G02
Stationary Arcing Contact Spring	4	5	6 [Ⓡ]	503B027H01	6 [Ⓡ]	503B027H01	6 [Ⓡ]	503B027H01
Stationary Main Contact Finger	4	6	6 [Ⓡ]	809A263G01	6 [Ⓡ]	809A263G01	12 [Ⓡ]	809A263G01
Stationary Main Contact Spring	4	7	3 [Ⓡ]	503B027H08	3 [Ⓡ]	503B027H08	6 [Ⓡ]	503B027H08
Following are included in Lower Stud Assembly:								
Moving Arcing Contact	4	8	3 [Ⓡ]	682C828G01	3 [Ⓡ]	682C828G01	3 [Ⓡ]	682C828G01
Moving Main Contact	4	9	6 [Ⓡ]	591C651G01	6 [Ⓡ]	591C651G01	12 [Ⓡ]	591C651G01
Insulating Link Assembly	4	10	3	788A588G01	3	788A588G01	3	788A588G03
Pin for Insulation Links ^④								
Center Pole	4	—	1	666A347H17	1	666A347H17	1	666A347H17
Left and Right Pole	4	—	2	3755A23H01	2	3755A23H01	2	3755A23H01
Main Disconnecting Contact Assembly ^③	3	—	6	591C655G02	6	591C655G02	6	591C655G03
Compartment Trip Lever	7	—	1	8295A03G01	1	8295A03G01	1	8295A03G01

[Ⓡ] Recommended Spare—See page 2.

● See page 16 figure 32 for illustration of the DSL-206.

● The DS-206S pole unit is not illustrated. The DS-206S pole unit assembly is similar to the DS-416 with the upper and lower stud assemblies mounted on a separate molded base for each pole rather than a common base for the three poles.

^③ Not included in pole unit assembly.
● X washers for pin installation listed on page 3 under DS Circuit Breaker Fastener Kit.

Type DS-416, DSL-416, DS-416S and DS-420 Pole Unit

DS-416 Pole Unit is illustrated. DS-416S and DS-420 Pole Unit Assemblies are similar

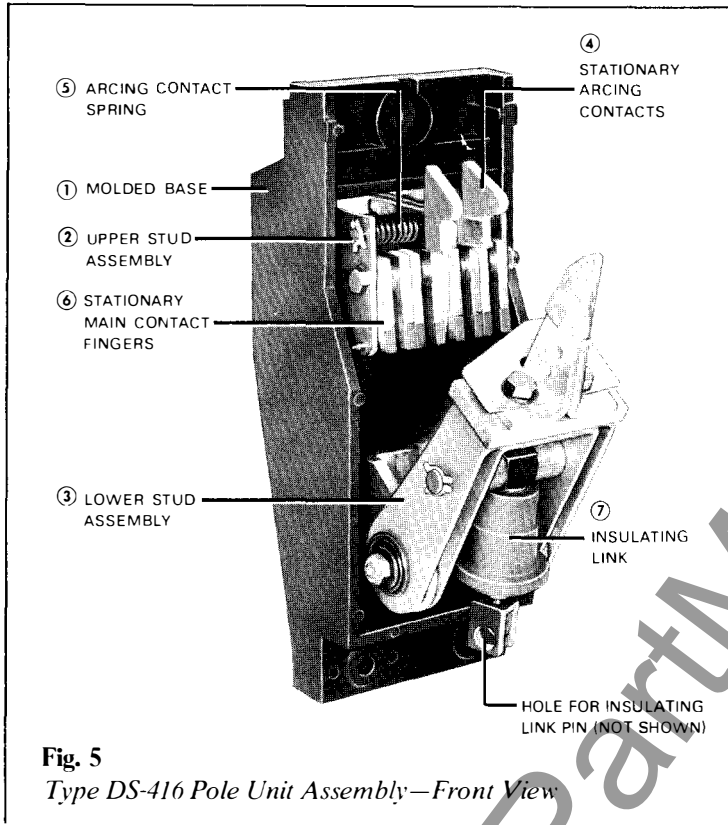

Fig. 5
Type DS-416 Pole Unit Assembly—Front View

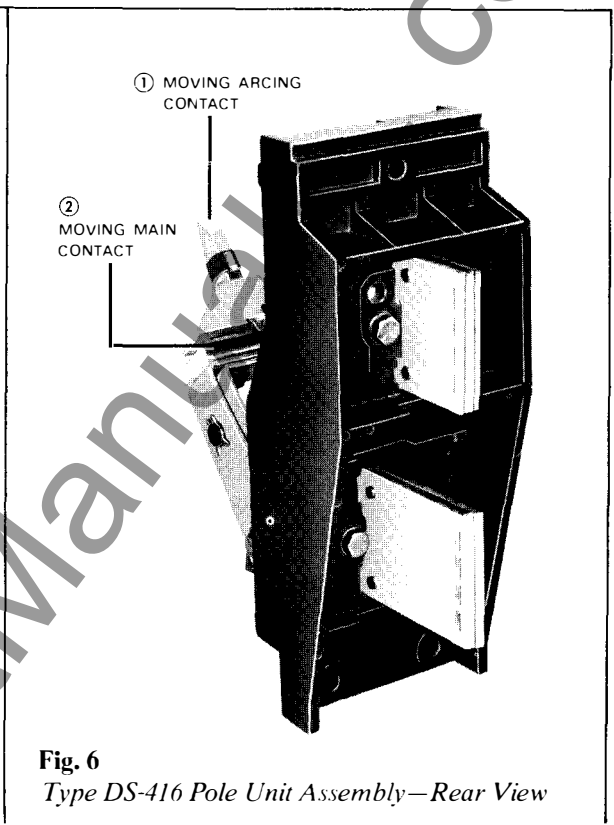

Fig. 6
Type DS-416 Pole Unit Assembly—Rear View

Description	Fig. No.	Item No.	DS-416		DSL-416 ^①		DS-416Sand DS-420	
			No. Req. Per Bkr.	Style Number	No. Req. Per Bkr.	Style Number	No. Req. Per Bkr.	Style Number
Single Pole Unit Assembly Complete	5-6	—	3	151D064G01	3	151D065G01	3	151D065G02
Following are included in Single Pole Unit Assembly:								
Molded Base	5	1	3	553F204H01	3	553F204H01	3	553F204H01
Upper Stud Assembly—Stat.	5	2	3	591C750G02	3 [®]	139D635G01	3 [®]	139D635G02
Lower Stud Assembly—Moving	5	3	3	126D298G06	3	139D633G04	3 [®]	139D633G05
Following are included in Upper Stud Assembly:								
Stationary Arcing Contact—R.H.	5	4	3 [®]	682C829G01	3 [®]	682C829G01	3 [®]	682C829G01
Stationary Arcing Contact—L.H.	5	4	3 [®]	682C829G02	3 [®]	682C829G02	3 [®]	682C829G02
Stationary Arcing Contact Spring	5	5	6 [®]	503B027H01	6 [®]	503B027H01	6 [®]	503B027H01
Stationary Main Contact Finger	5	6	24 [®]	809A263G01	36 (2) ^②	809A263G01	36 [®]	809A263G01
Stationary Main Contact Spring—Outer			12 [®]	503B027H05	12 (2) ^②	503B027H05	12 [®]	503B027H05
Stationary Main Contact Spring—Inner			—		12 (2) ^②	503B027H10	12 [®]	503B027H10
Following are included in Lower Stud Assembly:								
Moving Arcing Contact	6	1	3 [®]	682C827G01	3 [®]	682C827G01	3 [®]	682C827G01
Moving Main Contact	6	2	3 [®]	665A321G01	3 [®]	795A769G01	3 [®]	795A769G01
Insulating Link Assembly	5	7	3	436B450G02	3	436B450G02	3	436B450G02
Pin for Insulation Links ^④								
Center Pole	4	—	1	666A347H17	1	666A347H17	1	666A347H17
Left and Right Pole	4	—	2	3755A23H01	2	3755A23H01	2	3755A23H01
Main Disconnecting Contact Assembly ^⑤	3	—	6	682C347G01	6	682C347G01	6	590C804G01
Compartment Trip Lever	7	—	1	8295A03G01	1	8295A03G01	1	8295A03G01

[®] Recommended Spare—See page 2.

● See page 16 figure 33 for illustration of the DS-416.

② Assembly of the stationary main contact fingers and inner and outer springs is difficult. The Upper Stud Assembly is recommended for the DSL-416, DS-416S and DS-420.

③ Changing the moving main contact is complicated because of a drilling and pinning operation. The Lower Stud Assembly is recommended for the DS-416S and DS-420.

④ X washers for pin installation listed on page 3 under DS Circuit Breaker Fastener Kit.

● Not included in pole unit assembly.

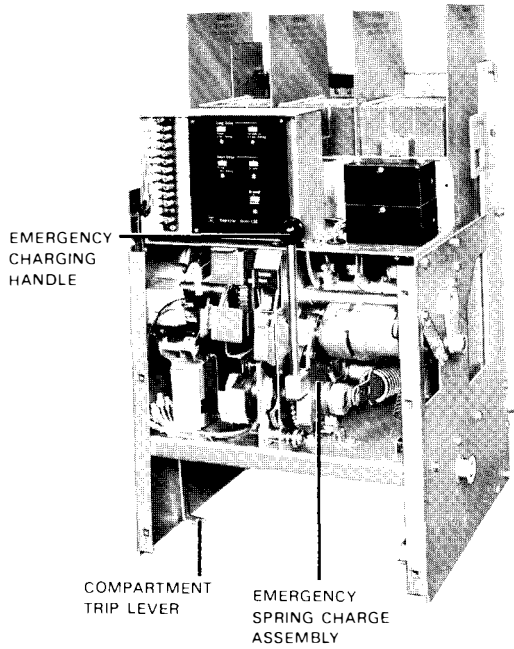

Fig. 7 DS-632 Breaker with Front Panel Removed

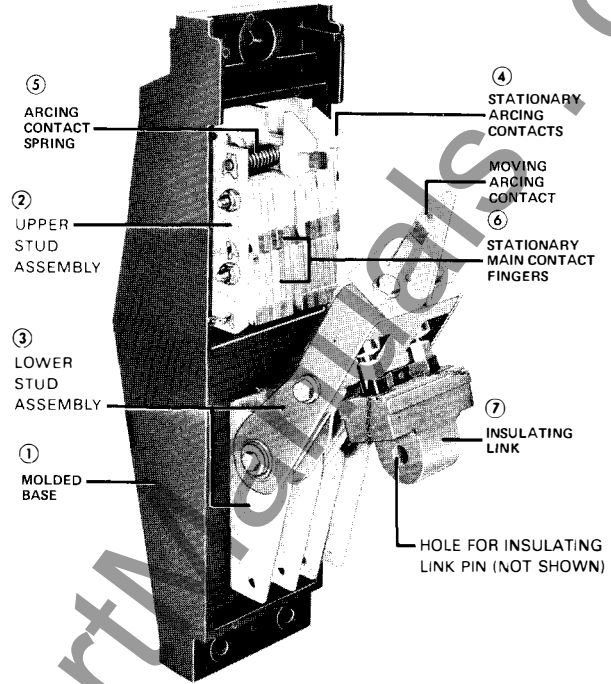

Fig. 8 Type DS-632 Pole Unit Assembly—Front View

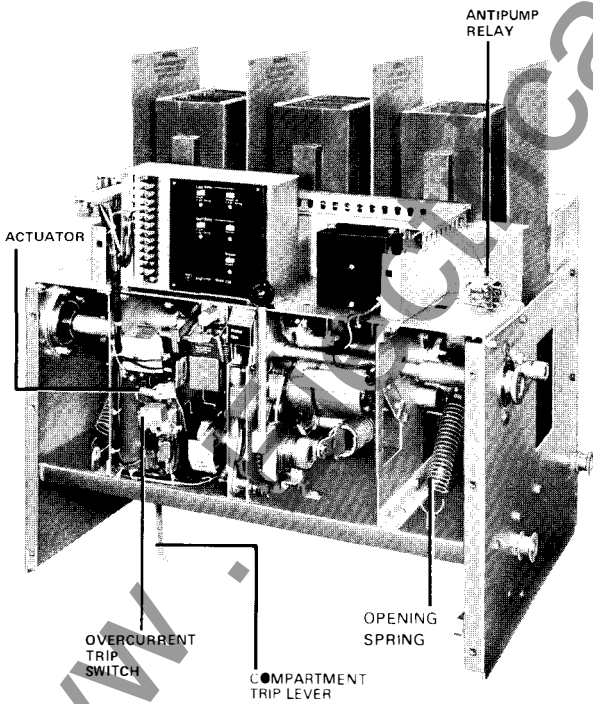

Fig. 10 DS-840 Breaker with Front Panel Removed

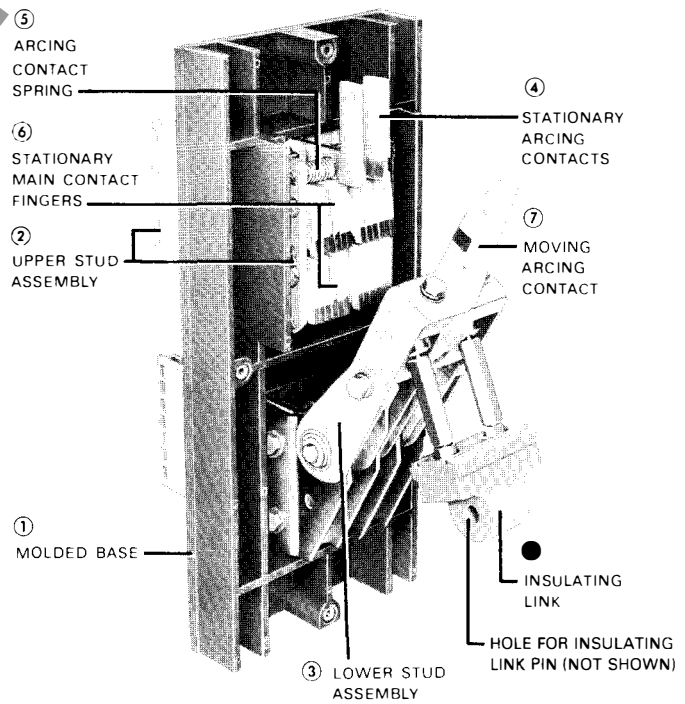

Fig. 11 Type DS-840 Pole Unit Assembly—Front View

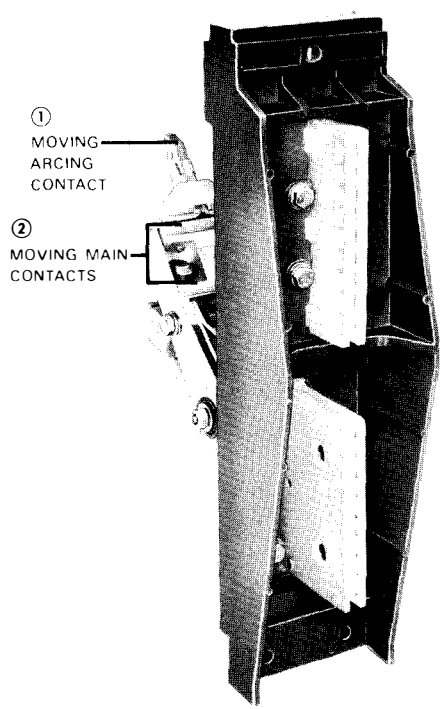

Fig. 9 Type DS-632 Pole Unit Assembly—Rear View

Type DS-632 Pole Unit

Description	Figure Number	Item No.	Number Required Per Bkr.	Style Number
Single Pole Unit Assembly Complete	8-9	—	3	567F962G01
Following are included in Single Pole Unit Assembly:				
Molded Base	8	1	3	553F205H01
Upper Stud Assembly	8	2	3 [®]	126D299G02
Lower Stud Assembly	8	3	3 [®]	140D091G05
Following are included in Upper Stud Assembly:				
Stationary Arcing Contact—R.H.	8	4	3 [®]	682C829G01
Stationary Arcing Contact—L.H.	8	4	3 [®]	682C829G02
Stationary Arcing Contact Spring	8	5	6 [®]	503B027H01
Stationary Main Contact Finger	8	6	72 ^①	809A263G01
Stationary Main Contact Spring—Outer			24 ^①	503B027H05
Stationary Main Contact Spring—Inner			24 ^①	503B027H10
Following are included in Lower Stud Assembly:				
Moving Arcing Contact	9	1	3 [®]	682C826G01
Moving Main Contact	9	2	3 ^②	794A105G01
Insulating Link Assembly	8	7	3	680C792G03
Pin for Insulation Links ^④	8, 11	—	3	666A347H07
Main Disconnecting Contact Assembly ^③	3	—	6	682C347G02
Compartment Trip Lever	7	—	1	8295A03G01

Type DS-840 Pole Unit

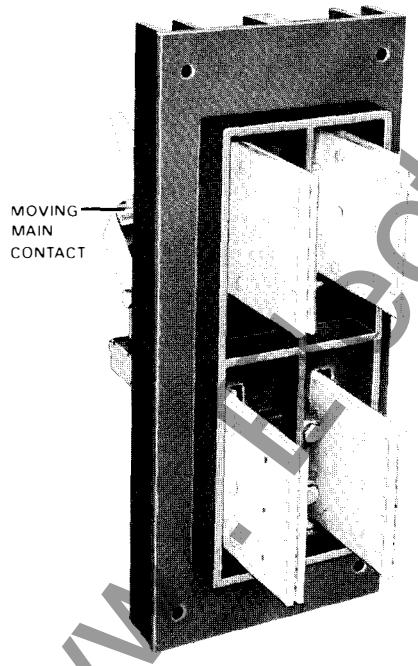

Fig. 12 Type DS-840 Pole Unit Assembly—Rear View

Description	Figure Number	Item No.	Number Required Per Bkr.	Style Number
Single Pole Unit Assembly Complete	11-12	—	3	567F991G03
Following are included in Single Pole Unit Assembly:				
Molded Base	11	1	3	567F501G01
Upper Stud Assembly	11	2	3 [®]	140D779G01
Lower Stud Assembly	11	3	3 [®]	140D778G01
Following are included in Upper Stud Assembly:				
Stationary Arcing Contact—R.H.	11	4	3 [®]	682C825G01
Stationary Arcing Contact—L.H.	11	4	3 [®]	682C825G02
Stationary Arcing Contact Spring	11	5	6 [®]	503B027H01
Stationary Main Contact Finger	11	6	72 ^①	809A263G01
Stationary Main Contact Spring—Outer			24 ^①	503B027H05
Stationary Main Contact Spring—Inner			24 ^①	503B027H10
Following are included in Lower Stud Assembly:				
Moving Arcing Contact	11	7	3 [®]	588C735G01
Moving Main Contact	12	—	3 ^②	794A105G01
Insulating Link Assembly	11	8	3	680C792G04
Pin for Insulation Links	8, 11 ^④	—	3	666A347H07
Main Disconnecting Contact Assembly ^③	3	—	12	591C100G01
Compartment Trip Lever	10	—	1	8295A15G01

[®] Recommended Spare—See page 2.

^① Assembly of the stationary main contact fingers and inner and outer springs is difficult. The Upper Stud Assembly is recommended.

^② Assembly of the moving main contact is difficult. The Lower Stud Assembly is recommended.

^③ Not included with pole unit assembly.

^④ X washers for pin installation page 3 under DS Circuit Breaker Fastener Kit.

Arc Chutes and Barriers

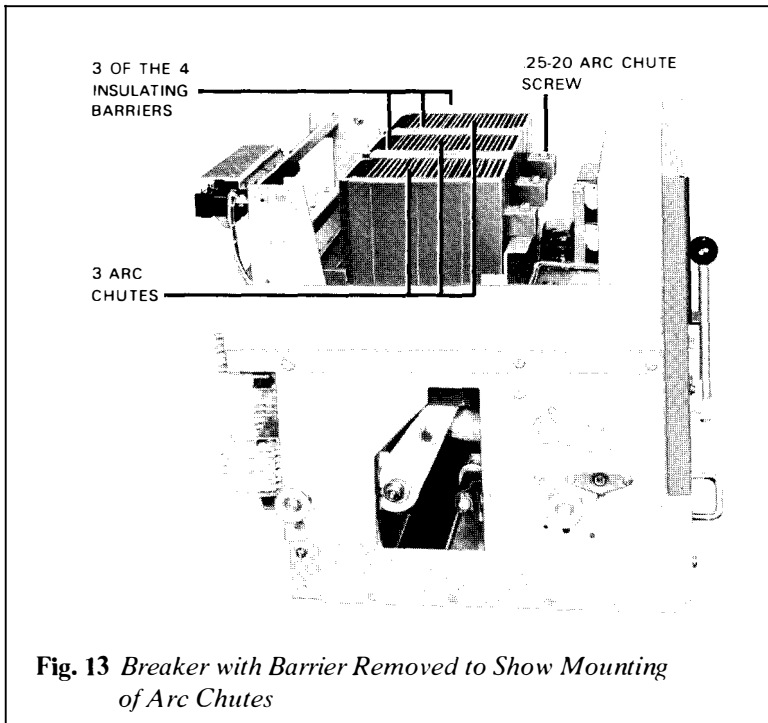

Fig. 13 Breaker with Barrier Removed to Show Mounting of Arc Chutes

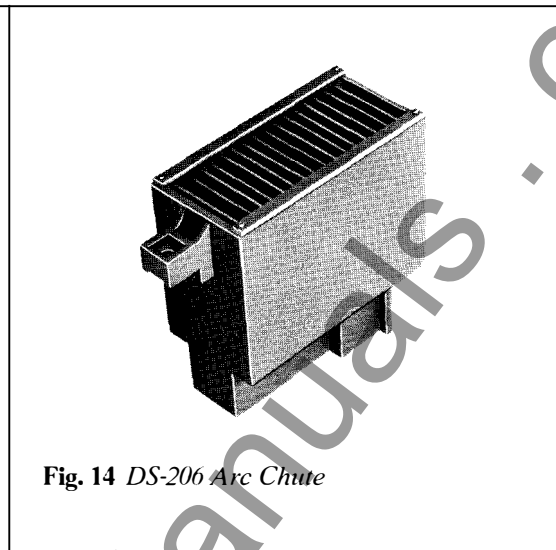

Fig. 14 DS-206 Arc Chute

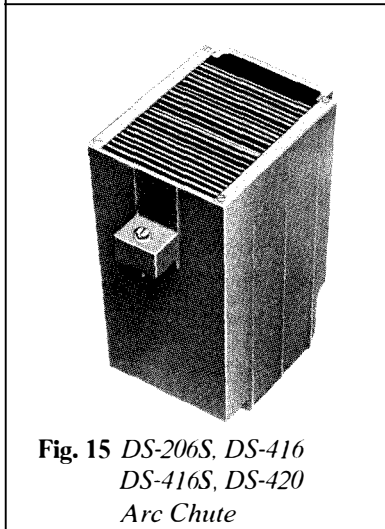

Fig. 15 DS-206S, DS-416, DS-416S, DS-420 Arc Chute

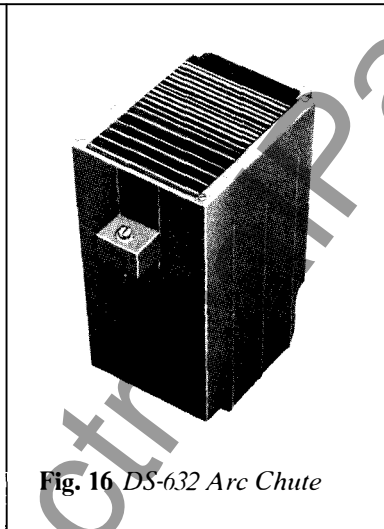

Fig. 16 DS-632 Arc Chute

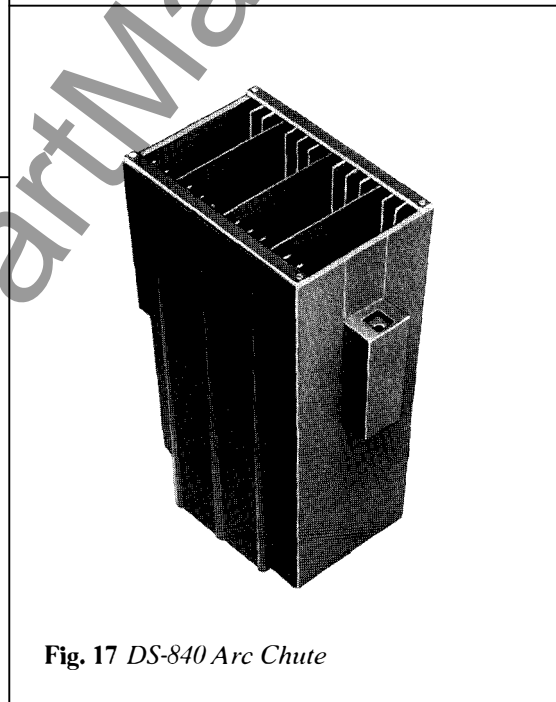

Fig. 17 DS-840 Arc Chute

Breaker Type	Assembled Arc Chute and Mounting Screw			Removable Insulating Barriers — Fig. 13			
	Figure Number	Number Required Per Breaker	Style Number	Outer		Inner	
				Number Required Per Breaker	Style Number	Number Required Per Breaker	Style Number
DS-206 DSL-206	14	3	449D508G01	2	349A578H01	2	788A586H01
DS-206S DS-416 DSL-416 DS-416S DS-420	15	3	151D018G01	2	349A578H01	2	349A578H01
DS-632 DS-840	16 17	3 3	151D018G02 140D164G01	2 2	436B108H02 803A735H01	2 2	436B108H01 803A735H01

Levering Mechanism

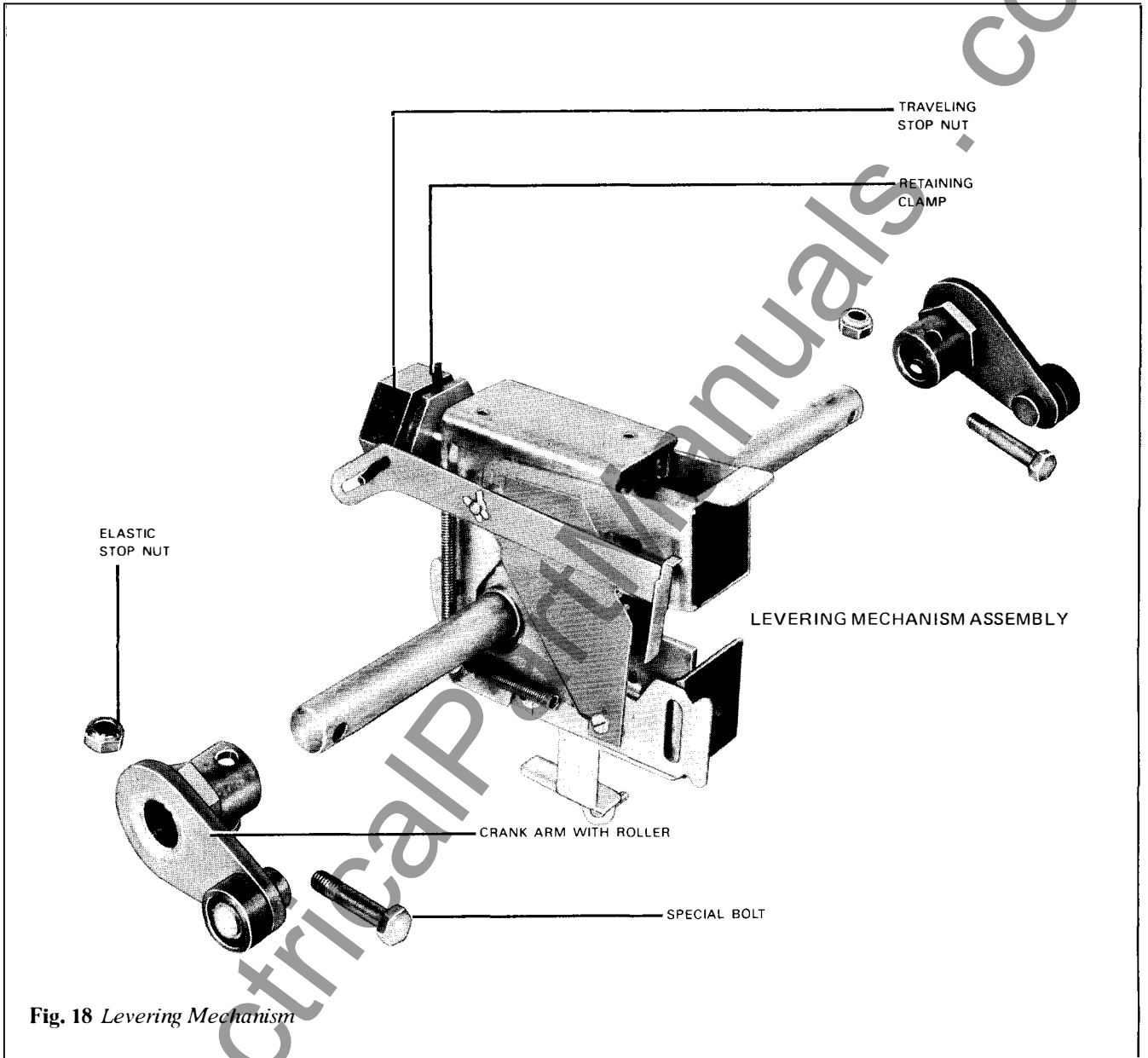

Fig. 18 Levering Mechanism

Levering Mechanism — Fig. 18

Description	Number Required per Breaker	All Type DS/DSL except DS-840	DS-840
		Style Number	Style Number
Levering Mechanism Assembly	1	449D224G04	449D224G05
Following are included in Assembly:			
Traveling Stop Nut	1	791A674H01	791A674H01
Retaining Clamp	1	791A679H01	791A679H01
Following are not included in Assembly:			
Crank Arm with Roller	2	786A586G01	567F993G02
Special Bolt	2①	792A024H01	792A024H01①
Elastic Stop Nut	2①	70220ERN18	70220ERN18① (5116-18)
Lever-in Crank Handle (Not Shown)	1	436B696G01	436B696G01

① For DS-840 four are required per breaker.

Mechanism and Related Parts

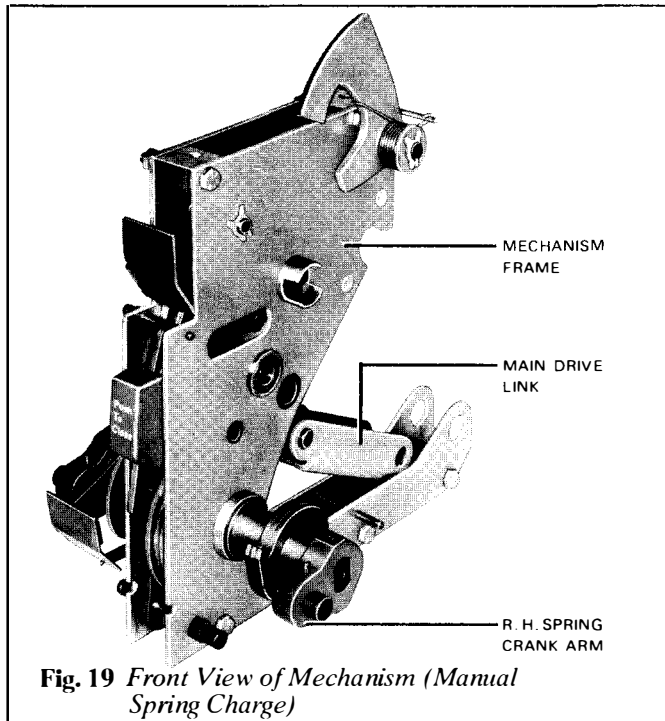

Fig. 19 Front View of Mechanism (Manual Spring Charge)

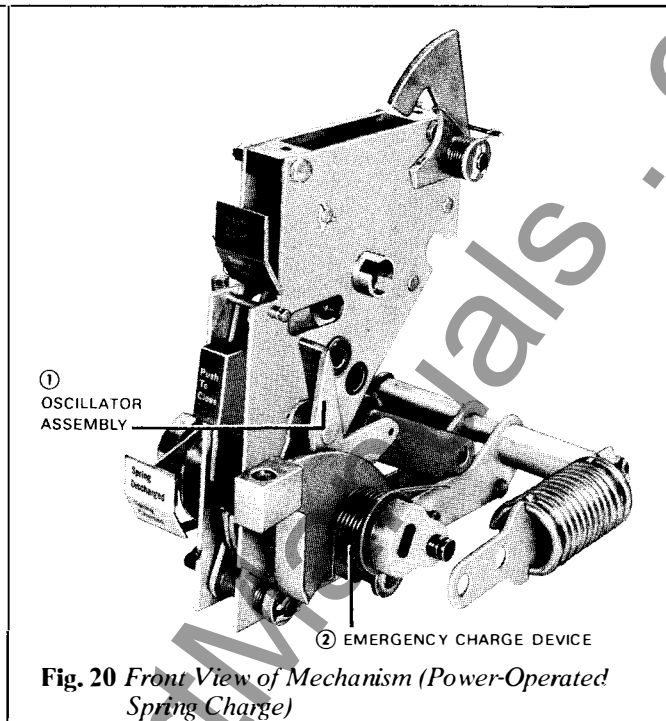

Fig. 20 Front View of Mechanism (Power-Operated Spring Charge)

All DS/DSL except DS-632 and DS-840

Description	Power Operated				Manual Operated		
	Number Required per Breaker	Fig. No.	Item No.	Style Number	Fig. No.	Item No.	Style Number
Mechanism Assembly (Without Closing Spring)	1	20	—	567F759G02	19	—	567F759G01
Following are included in Mechanism Assembly:							
Main Drive Link Ass'y. (With Roller)	1	21	1-2	437B146G03	21	1-2	437B146G03
Oscillator Ass'y.	1	20	1	436B923G01			*
Oscillator Reset	1	—	—	® 503B601H11			*
Spring (Not Illustrated)							*
Emergency Charge Device	1	20	2	436B925G01			*
Trip Latch	1	22	1	3755A19G01	22	1	3755A19G01
Lever (for motor cut-off switch)	1	22	2	791A516H01	22	2	791A516H01
Trip Latch Reset Spring	1	22	3	® 795A077H01	22	3	® 795A077H01
Following are not included in Mechanism Assembly:							
Manual Charge Ass'y. (Without Handle)	1			*	23	8	591C3B5G01
Manual Charge Handle	1			*	23	9	349A669G01
Emergency Charge Handle	1	2	—	349A669G03			*
Trip Shaft	1	23	2	349A613G01	23	2	349A613G01
Trip Shaft Lever	1	23	3	437B381H01	23	3	437B381H01
Trip Shaft Return Spring	4	23	4	® 436B621H05	23	4	® 436B621H05
Opening Spring	1	2	—	® 503B601H04	2	—	® 503B601H04
Motor, incl. Crank & Connectors	1	23	10	® See Page 12			*
Closing Spring Ass'y.	2	21	3-4		21	3-4	
DS-206				349A521G01			349A521G01
DS-206S							
DS-416				791A671G02			791A671G02
DS-416S							
DS-420				791A671G01			791A671G01

Mechanism and Related Parts

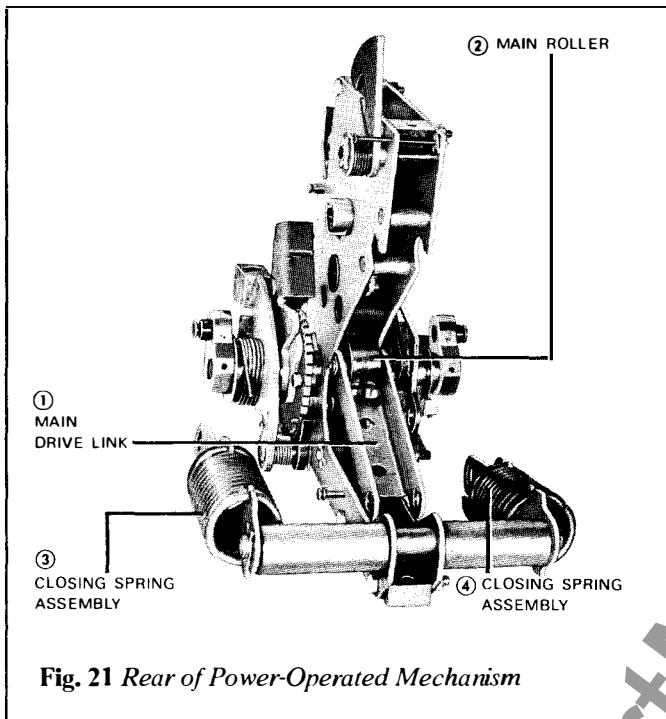

Fig. 21 Rear of Power-Operated Mechanism

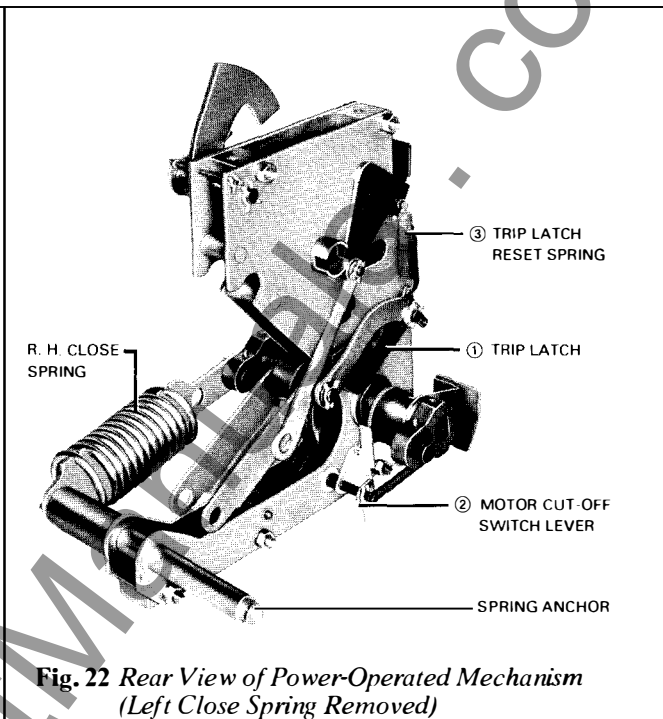

Fig. 22 Rear View of Power-Operated Mechanism (Left Close Spring Removed)

DS-632 and DS-840

Description	Number Required per Breaker	① Fig. No.	Power Operated		Manual Operated		
			Item No.	Style Number	① Fig. No.	Item No.	Style Number
Mechanism Assembly (Without Closing Spring)	1	20	—	567F759G04	19	—	567F759G07
Following are included in Mechanism Assembly:							
Main Drive Link Ass'y. (With Roller)	1	21	1-2	437B146G04	21	1-2	437B146G04
Oscillator Ass'y.	1	20	1	436B923G01			*
Oscillator Reset Spring (Not Illustrated)	1		—	® 503B601H11			*
Emergency Charge Device	1	20	2	436B925G01			*
Trip Latch	1	22	1	3755A19G01	22	1	3755A19G01
Lever (for motor cut-off switch)	1	22	2	791A516H01	22	2	791A516H01
Trip Latch Reset Spring	1	22	3	® 795A077H01	22	3	® 795A077H01
Following are not included in Mechanism Assembly:							
Manual Charge Ass'y. (Without Handle)	1			*	23	8	591C385G01
Manual Charge Handle	1			*	23	9	349A669G01
Emergency Charge Handle	1	7	—	349A669G03			*
Trip Shaft	1	23	2	349A613G01	23	2	349A613G01
Trip Shaft Lever	1	23	3	437B381H01	23	3	437B381H01
Trip Shaft Return Spring	4	23	4	® 436B621H05	23	4	® 436B621H05
Opening Spring	1②	8	—	® 503B601H04	8	—	® 503B601H04
Motor, incl. Crank & Connectors	1	23	10	® See Page 12			*
Closing Spring Ass'y.	2	21	3-4	791A671G03	21	3-4	791A671G03

® Recommended Spare — See page 2.

*Not Required.

① Figures 19 thru 22 illustrate mechanism for all DS/DSL breakers except DS-632 and DS-840. DS-632 and DS-840 mechanisms are similar.

② Two opening springs are required for DS-840.

Mechanism and Related Parts

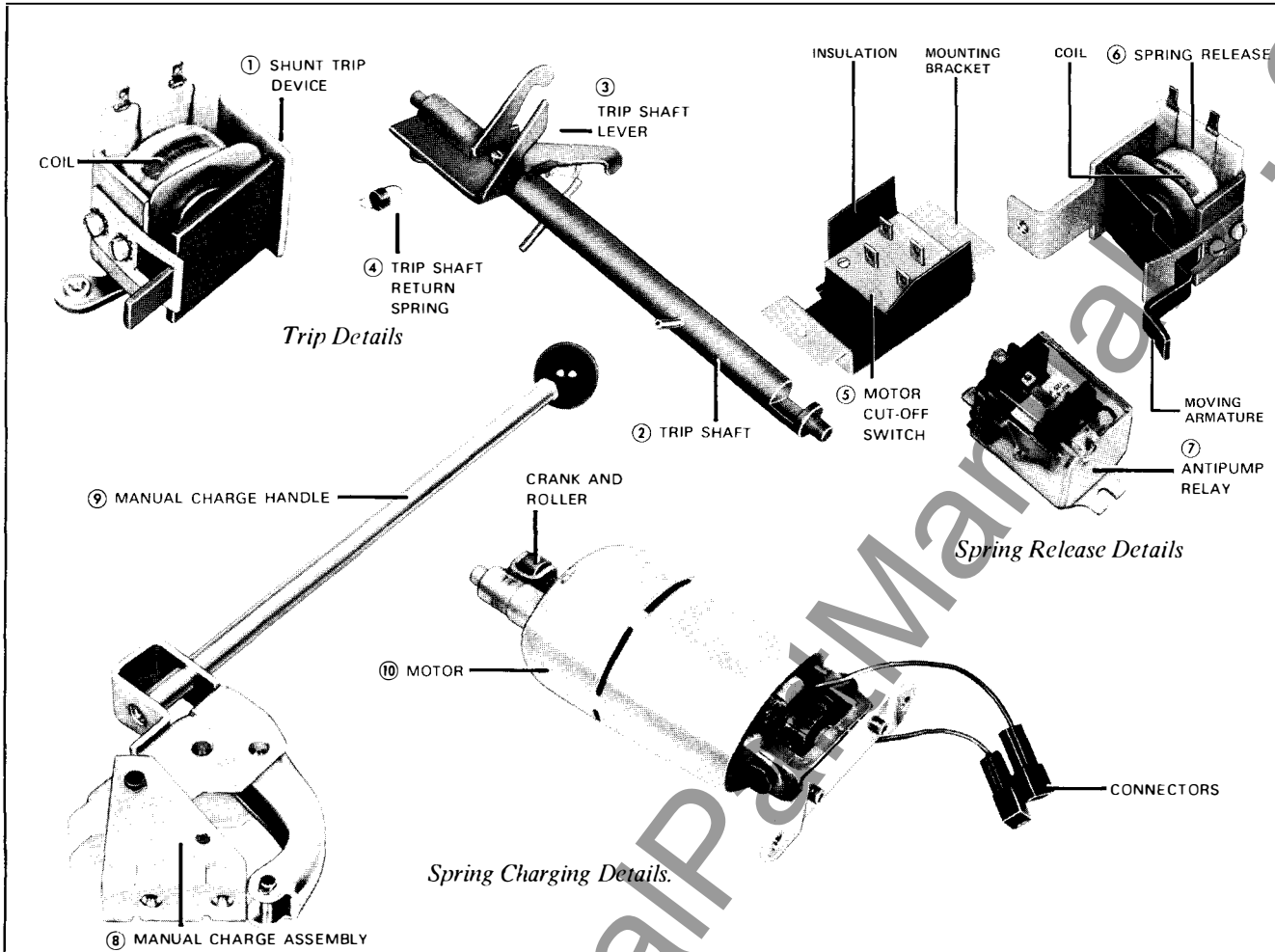

Fig. 23 Trip, Spring Release, and Spring Charging Details

Voltage	Shunt Trip ^① Fig. No. 23 Item No. 1	Spring Release ^① Fig. No. 23 Item No. 6	®Anti-Pump Relay Fig. No. 23 Item No. 7	®Motor Kit ^④ Fig. No. 23 Item No. 10
	Complete Assembly	Complete Assembly		
	DS/DSL except DS-840 ^②	DS/DSL except DS-840 ^③		
24 DC	3752A02G01	—	—	—
32 DC	3752A02G02	—	—	—
48 DC	3752A02G03	3752A03G01	140D930H03	449D431G03
125 DC	3752A02G04	3752A03G02	140D930H04	449D431G01
250 DC	3752A02G05	3752A03G03	140D930G05	449D431G02
120 60 HZ	3752A02G06	3752A03G04	140D930H01	449D431G01
240 60 HZ	3752A02G07	3752A03G05	140D930H02	449D431G02
For Use with Capacitor Trip	3752A02G08	—	—	—

®Motor Cut-off Switch—All breakers—Style 567F430G06 Fig. 23—Item 5. Includes Motor Cutoff Switch, Mounting Bracket and Insulation.

② Recommended Spare—See page 2.

② For DS-840 use corresponding groups of 3752A22.

① Shunt Trip and Spring Release complete assembly includes mounting hardware and wire leads for field replacement. When adding shunt trip or spring release to manual breakers, an auxiliary switch, secondary contacts, and covers, wiring guides, and possibly other components will be required. All changes or additions on the breaker should be wired to the standard drawing 800A600 and indicate the change on the breaker nameplate.

③ For DS-840 use corresponding groups of 3752A23.

④ Motor Kit includes crank and roller and connectors for field replacement.

Type DS Circuit Breaker Automatic Tripping System

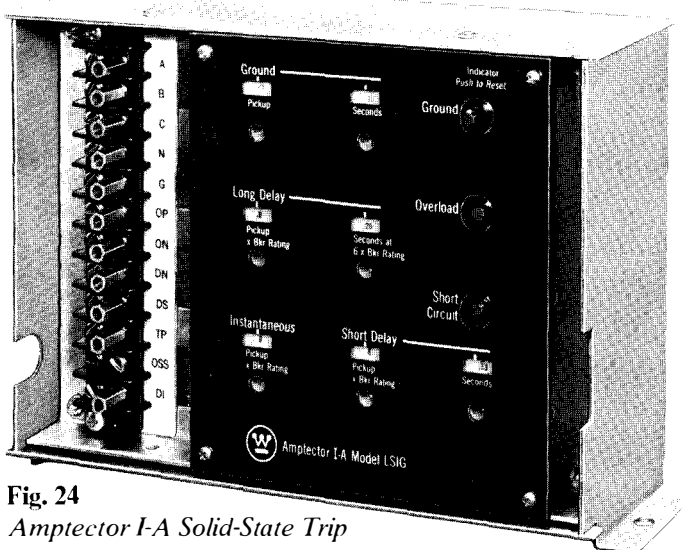

Fig. 24
Amptector I-A Solid-State Trip

Amptector I-A can be supplied in various combinations of four independent continuously adjustable overcurrent tripping functions:

Long delay (L), Short delay (S), Instantaneous (I), Ground (G)

The following combinations are available:
LI, LIG, LS, LSG, LSI, LSIG

Model	Style Number — 60 HZ
LI	6998D02G01
LIG	6998D02G02 (1)
LS	6998D02G03
LSG	6998D02G04 (1)
LSIG	6998D02G05 (1)
LSI	6998D02G06

(1) For DS-632 and DS-840 use Groups 62, 64, 65 and 82, 84, 85 respectively.

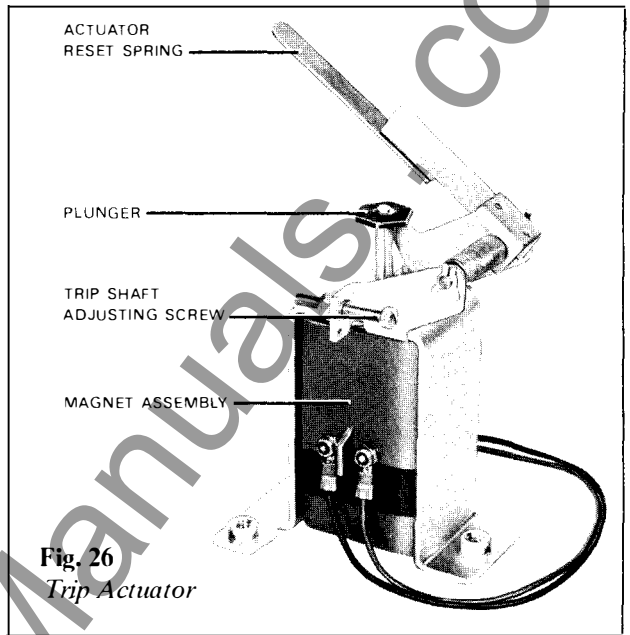

Fig. 26
Trip Actuator

DIRECT TRIP ACTUATOR FIGURE NO. 26

All type DS Breakers use Style Number 6482C55G01 (with Black Magnet Ass'y).

Exception: If a breaker is equipped with an earlier Amptector II Style 151D792G series or Amptector I 139D643G series, the Amptector must also be changed in addition to the actuator.

SENSORS

See Figure 3 for Typical Sensors

Refer to I.B. 33-790-1F, Table 4, for application of sensors.

Sensor Rating Amperes	Sensor ^① Style Number
50	436B080G01
100	151D995G01
150	151D995G15
200	151D995G02
300	151D995G03
400	151D995G04
600	151D995G06
800	151D995G08
1200	151D995G12
1600	151D995G16
2000	151D995G20
2400	151D995G24
3200	151D995G32
4000	588C734G01

^① These are replacements for sensors of S#794A170G series.

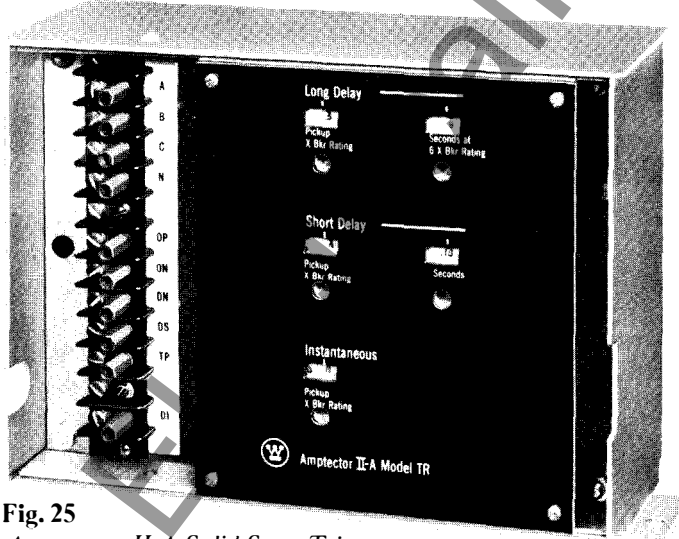

Fig. 25
Amptector II-A Solid-State Trip

Amptector II-A can be supplied in three models or combinations of three independent continuously adjustable overcurrent tripping functions: long delay, short delay and instantaneous. These models are:

DU (Dual—Long delay and instantaneous)

SE (Selective)—Long delay and short delay

TR (Triple)—Long delay, short delay and instantaneous

Model	Style Number — 60 HZ
DU	6997D20G41
SE	6997D20G42
TR	6997D20G43

NOTE:

On type DS-206/DSL-206 two (2) spacers S#794A965H01 are required for each sensor.

NOTE:

For information on application and operation of the automatic tripping system refer to Section 8 of Instruction Book 33-790-1F.

Optional Accessories

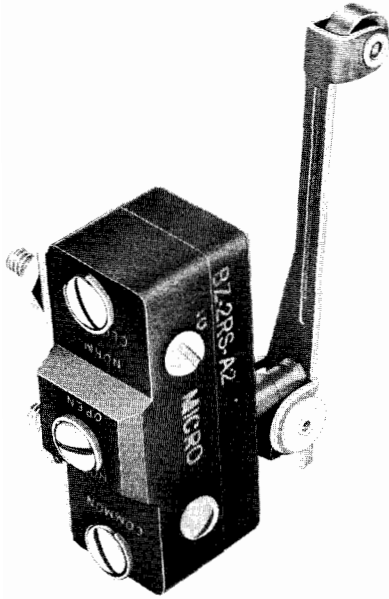
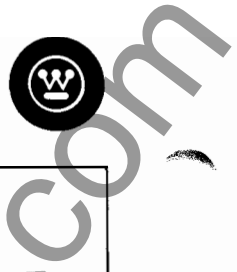

Fig. 27 Latch Check Switch—Style 140D161G01



Fig. 28 Auxiliary Switches—See page 3 for identification of auxiliary switches.

NOTE:

Wiring additions should be consistent with breaker standard wiring practices. Wiring guides when required, are located on the left side of the breaker with inside and outside guides (Figs. 2 & 3). One guide is also located at the rear of the amptector and one between the right side of the amptector and auxiliary switches.

For DS-206, DS-206S, 416, 416S, 420, DS-532 and DS-632

- Outside Guide S#437B242H01
- Inside Guide S#3702A37G01
- Rear Guide S#588C990H01
- Right of Amptector S#436B111H01

NEW AUXILIARY SWITCHES ① (FIELD ADDITIONS TO EXISTING DS BREAKERS)	
1 AUX. SWITCH	697B536G01
2 AUX. SWITCHES	697B536G02
3 AUX. SWITCHES	697B536G03

*-Also order secondary contacts as reqd.
 -For breaker - 591C498G06
 -For compartment - 590C808G01
 -If existing breaker does not have secondary contacts, one mounting bracket per breaker must be ordered 436B657G01

ADDITIONAL AUX. SWITCHES ① (ADDITIONS TO BKRS. WITH EXISTING AUX. SWS.)	
2 ND AUX. SWITCH	697B536G08
3 RD AUX. SWITCH	697B536G09

*-Also order secondary contacts as reqd.
 -For breaker - 591C498G06
 -For compartment - 590C808G01

REPLACEMENT AUX. SWITCHES (TO REPLACE EXISTING AUXILIARY SW. ONLY)	
1 ST AUX. SWITCH	697B536G04
2 ND AUX. SWITCH	697B536G05
3 RD AUX. SWITCH	697B536G06

Cover S#302C225H13
 Cover Screw 70030ATJ5N

① Linkage Included.

Optional Accessories

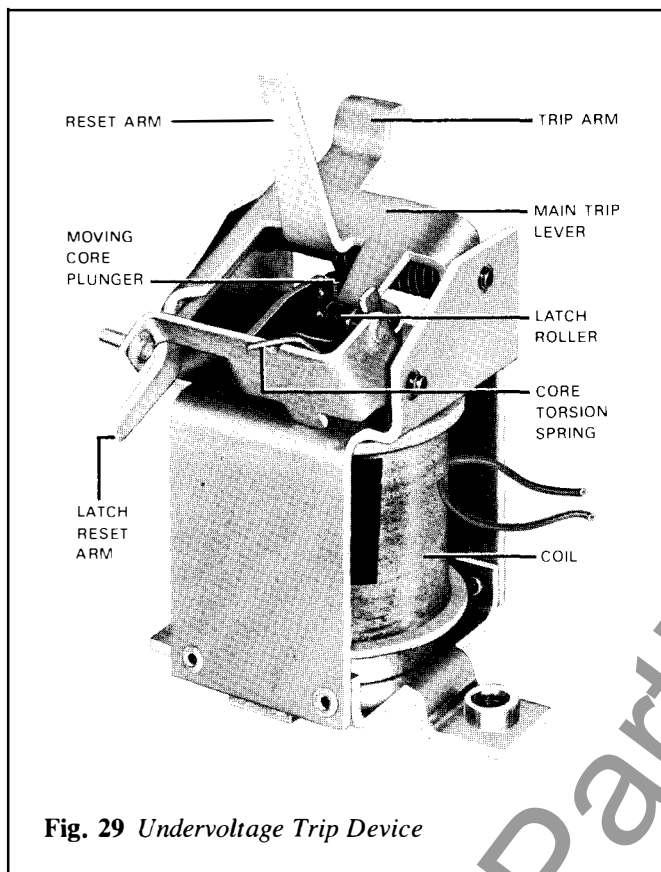

Fig. 29 Undervoltage Trip Device

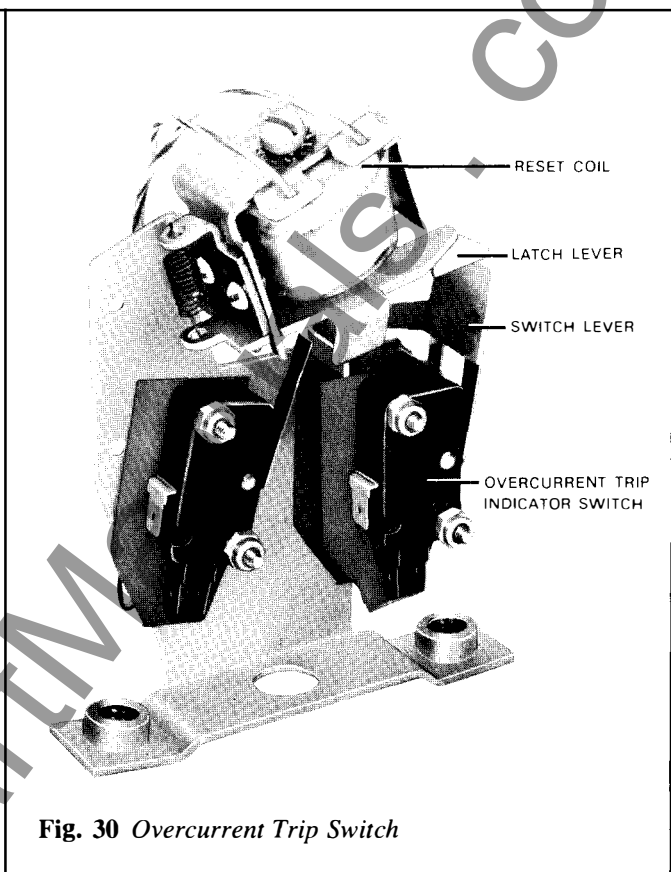

Fig. 30 Overcurrent Trip Switch

UNDervOLTAGE TRIP DEVICE—FIGURE NO. 29

Voltage	Undervoltage-Instantaneous	Undervoltage-Time Delay
	All DS/DSL Except DS-840 ①	All DS/DSL Except DS-840 ②
120 60 HZ	3752A05G01	3752A06G01
208 60 HZ	3752A05G02	3752A06G02
240 60 HZ	3752A05G03	3752A06G03
480 60 HZ	3752A05G04	3752A06G04
48 DC	3752A05G05	3752A06G05
125 DC	3752A05G06	3752A06G06
250 DC	3752A05G07	3752A06G07

① For DS-840 use corresponding groups of 3752A25

② For DS-840 use corresponding groups of 3752A26

Special Voltage	All DS/DSL including DS-840	All DS/DSL including DS-840
24 DC	3752A45G01	3752A46G01
115 50 HZ	3752A45G02	3752A46G02
208 50 HZ	3752A45G03	3752A46G03
230 50 HZ	3752A45G04	3752A46G04
400 415/50 HZ	3752A45G05	3752A46G05
480 50 HZ	3752A45G06	3752A46G06

NOTES:

All styles include mounting hardware and wire leads for field replacement. When adding to existing breakers, secondary contacts will be required.

The undervoltage trip device is available as a complete assembly. The coil only is not recommended as it is riveted into the assembly.

OVERCURRENT TRIP SWITCH—FIGURE NO. 30

For all type DS/DSL except DS-840 ①

Manual Reset			
	2 Contact	3 Contact	4 Contact
	3752A04G01	3752A04G02	3752A04G03
Electrical Reset			
Voltage	2 Contact	3 Contact	
48 DC	3752A04G04	3752A04G09	
115 AC	3752A04G05	3752A04G10	
125 DC	3752A04G06	3752A04G11	
230 AC	3752A04G07	3752A04G12	
250 DC	3752A04G08	3752A04G13	

① For DS-840 use corresponding groups of 3752A24.

All styles include mounting hardware and wire leads for field replacement. When adding to existing breakers other components may be needed.

For replacement of switches only order style 3752A04G15 which consists of two switches, a switch bracket and rivets.

Overcurrent trip reset pushbutton and nameplate S#809A779G02.

DSL-206 and DSL-416 Breakers

Parts for pole units, arc chutes, mechanisms, etc. for DSL breakers are identified on preceding pages of this R.P.D.

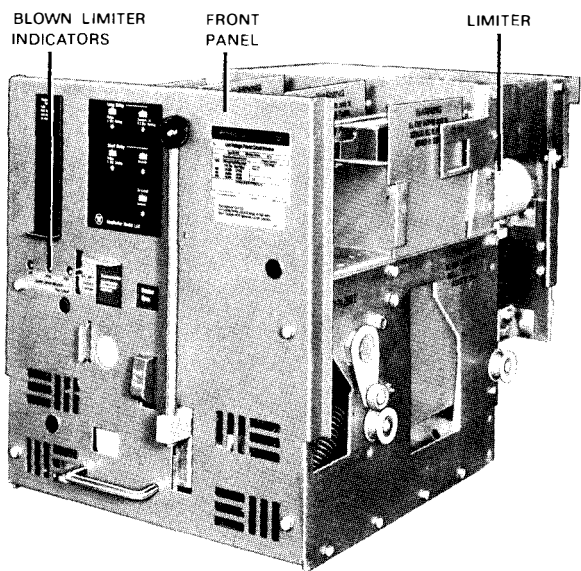

Description	Fig. No.	Number Required per Breaker	DSL-206 and DSL-416 Style Number
Blown Limiter Indicator Ass'y.	32	1	140D777G01
Isolating Transformer Ass'y. (includes 3 transformers)	33	1	591C755G01
Transformer Only:	33	3	795A823H01

Fig. 31 DSL-206 Breaker—Front View

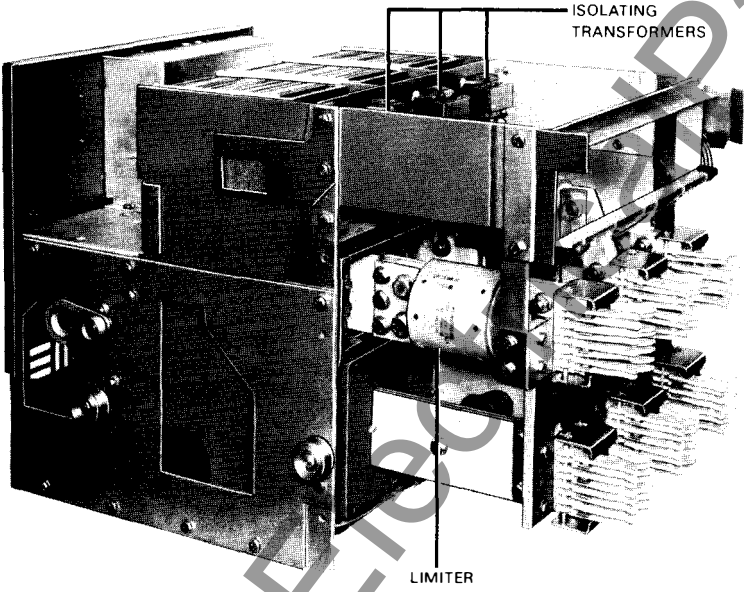

® LIMITERS—FIGURES 31-32

Refer to I.B. 33-790-1E, Table 5, for application of limiters.

Breaker Type	Number Required per Breaker	Rating Amps	Style Number	
DSL-206	3	150	140D316G01	
	3	200	140D316G02	
	3	250	140D316G03	
	3	300	140D316G04	
	3	400	140D316G05	
	3	600	140D316G06	
	3	800	140D316G07	
	3	1200	140D316G10	
	3	1600	140D316G11	
	3	2000	140D316G12	
	DSL-416	3	800	151D932G01
		3	1000	151D932G02
3		1200	151D932G03	
3		1600	151D932G04	
3		2000	151D932G05	
3		2500	151D932G09	
3		3000	151D932G10	
3		2500	5980C01G01	
3		3000	5980C01G02	
DS-3200①	3	3000	5980C01G02	
DS3200①,	3	4000	5980C01G03	
DS4000①	3	5000	5980C01G04	

Fig. 32 DSL-416 Breaker—Side View

® Recommend 3 spare limiters of each current rating.
 ① Separate fuse trucks.

Feeder Circuit Instrumentation

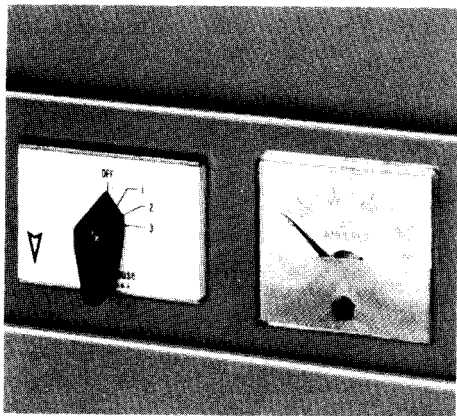

Fig. 33 *Miniature Ammeter and Three Phase Ammeter Switch (arrow down)*

For feeder circuit instrumentation, 2% accuracy class miniature ammeters and Type W-2 ammeter switches can be mounted on the horizontal stationary panels adjacent to the breaker compartment doors. The ammeters and switches are immediately associated with definite breaker circuits.

MINIATURE AMMETERS

Scale	Style Number
0-100A	7497A98H01
0-150A	7497A98H02
0-200A	7497A98H03
0-300A	7497A98H04
0-400A	7497A98H05
0-500A	7497A98H06
0-600A	7497A98H07
0-800A	7497A98H08
0-1000A	7497A98H09
0-1200A	7497A98H10
0-1500A	7497A98H11
0-1600A	7497A98H12
0-2000A	7497A98H13
0-2500A	7497A98H14
0-3000A	7497A98H15
0-4000A	7497A98H16

NOTE: All ammeters are 5A full scale.

AMMETER SWITCHES

For fixed meter panel mounting

W-2 Switch	2 CT's	(Arrow Down)	Style No. 787A984G01
W-2 Switch	2 CT's	(Arrow Up)	Style No. 787A984G02
W-2 Switch	3 CT's	(Arrow Down)	Style No. 787A984G03
W-2 Switch	3 CT's	(Arrow Up)	Style No. 787A984G04

Ammeter switches are UL listed, and are for end-of-circuit application only. Ammeter and switch mounting plate, Style No. 6949D51H03.

METERING CURRENT TRANSFORMERS

NOTE:

To be used for metering and instrumentation only. Do not use for relaying.

Breaker	Description	Ratio	Style Number
①	RCT-1600	100/5	449D701G01
①	RCT-1600	150/5	449D701G02
①	RCT-1600	200/5	449D701G03
①	RCT-1600	300/5	449D701G04
①	RCT-1600	400/5	449D701G05
①	RCT-1600	600/5	449D701G06
①	RCT-1600	800/5	449D701G07
①	RCT-1600	1200/5	449D701G08
①	RCT-1600	1500/5	449D701G18
①	RCT-1600	1600/5	449D701G09
①	RCT-1600	2000/5	449D701G10
②	RCT-3200	2400/5	449D701G11
①	RCT-1600	2500/5	449D701G19
①	RCT-1600	3000/5	449D701G20
②	RCT-3200	3200/5	449D701G12
③	RCT-4000	4000/5	151D026G01
③	RCT-4000	5000/5	151D026G02
③	RCT-4000	6000/5	151D026G03
②	RCT-3200	2500/5	449D701G14
②	RCT-3200	3000/5	449D701G15
②	RCT-3200	4000/5	449D701G13

- ① Use with drawout breakers – DS-206, DS-206S, DS-416, DS-420, DSL-206, or DSL-416.
- ② Use with drawout breakers – DS-532 or DS-632.
- ③ Use with drawout breaker – DS-840.

www.ElectricalManuals.com

Interference Interlocks

On original equipment, interference interlocks are supplied on breakers and in compartments where the compartments are of the same physical size, to insure that a Type DS-206 breaker cannot be inserted into a compartment intended for a Type DS-416 or DS-420 breaker, and a Type DS-416 or DS-420 breaker cannot be inserted into a compartment for a Type DS-206 breaker. It is important that when equipping any blank breaker cell that proper installation of the correct interference brackets be followed.

When ordering complete parts for blank cells, interference brackets will be included.

If additional brackets are required they are available by ordering the following style numbers.

Breaker Type	Style Number
DS-206	436B677H01 (1) - 502B278H02 (1)
DS-206S	507B278H01 (2) - 502B278H02 (1)
DS-416	436B677H01 (1) - 502B278H02 (1)
DS-416S	502B278H01 (2) - 502B278H02 (1)
DS-420	502B278H01 (2) - 502B278H02 (1)
DSL-206	803A553H01 (1) - 502B278H02 (1)
DSL-416	803A553H01 (1) - 502B278H02 (1)

KEY INTERLOCKS

Key interlocks are operative only after breakers have been withdrawn beyond the Disconnect Position. No modification of the breaker is required and storage of breaker within the cell is possible. The breaker can be removed for use as a spare without disturbing the interlock.

Breaker Type	Style Number
DS-206 and DSL-206	6953D99G01
DS-416 and DSL-416	6953D99G01
DS-420	6953D99G01
DS-632	6953D99G02
DS-840	6953D99G03

BREAKER CELL PARTS – SEE TABLE 1

Where original switchgear lineups were supplied with blank compartments complete cell parts can be ordered. The styles listed include the following items.

- Breaker mounting pan with ground pad
- Breaker extensions rails
- Breaker door with handle/hinge/trip button
- Floor mounted trip interlock mechanism
- Current transformer mounting plate
- Line side stabs*
- Load side runbacks and supports*
- Necessary gas and arc shields

*Styles listed are for switchgear manufactured with shop order number series 24Y— and 27Y—. Switchgear identified by shop orders other than 24Y and 27Y, refer to St. Louis DED.

Cell Swt. 800A117G06 – 6 pole 2a 2b contacts

Cell Swt. 800A118G06 – 12 pole 6a 6b contacts

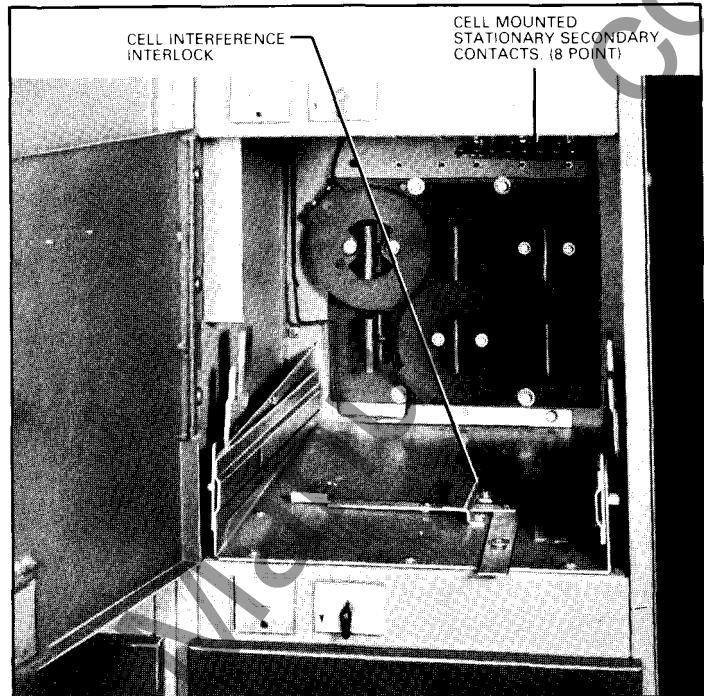

Fig. 34 Interference Bracket (set-up shown for a DS-416 breaker)

OPTIONAL ITEMS:

- Secondary Contacts
- Compartment Switch (6P or 12P)
- Heater
- Current Transformers
- Seismic Positioner
- Ammeter and Ammeter Switch
- Pushbuttons and Lights
- Key Interlock

It is most important that the correct style be selected after careful consideration of the following:

1. Cell location to be outfitted.
2. The riser material, copper or aluminum.
3. The bus compartment depth, 10 or 15 inches.
4. The breaker compartment depth, 27 or 35 inches.

Refer to Fig. 34 for a typical equipped cell.

Insulation boots for live side stabs —

All DS breakers except DS-632 and DS-840

S#140D294H02 – 6 reqd. per compt.

DS-632 breaker (2 required per pole)

S#140D768H01 – 3 each

S#140D769H01 – 3 each reqd. per compt.

There are no boots available for DS-840 breakers.

TABLE NO. 1 – BREAKER CELL PARTS

Breaker Type	Cell Location	Riser	Bus Compt. Depth	Front Compt. Depth	Style Number
DS-206	A	Alum.	10	27	9118D97G01
DS-206	B,C,D	Alum.	10	27	9118D97G02
DS-206	A	Alum.	15	27	9118D97G04
DS-206	B,C,D	Alum.	15	27	9118D97G05
DS-206	A	Cu.	10	27	9118D97G07
DS-206	B,C,D	Cu.	10	27	9118D97G08
DS-206	A	Cu.	15	27	9118D97G10
DS-206	B,C,D	Cu.	15	27	9118D97G11
DSL-206	A	Alum.	10	35	9118D97G13
DSL-206	B,C,D	Alum.	10	35	9118D97G14
DSL-206	A	Alum.	15	35	9118D97G16
DSL-206	B,C,D	Alum.	15	35	9118D97G17
DSL-206	A	Cu.	10	35	9118D97G19
DSL-206	B,C,D	Cu.	10	35	9118D97G20
DSL-206	A	Cu.	15	35	9118D97G22
DSL-206	B,C,D	Cu.	15	35	9118D97G23
DS-206	A	Alum.	10	35	9118D97G25
DS-206	B,C,D	Alum.	10	35	9118D97G26
DS-206	A	Alum.	15	35	9118D97G28
DS-206	B,C,D	Alum.	15	35	9118D97G29
DS-206	A	Cu.	10	35	9118D97G31
DS-206	B,C,D	Cu.	10	35	9118D97G32
DS-206	A	Cu.	15	35	9118D97G34
DS-206	B,C,D	Cu.	15	35	9118D97G35
DS-416	A	Alum.	10	27	9118D97G37
DS-416	B,C,D	Alum.	10	27	9118D97G38
DS-416	A	Alum.	15	27	9118D97G40
DS-416	B,C,D	Alum.	15	27	9118D97G41
DS-416	A	Cu.	10	27	9118D97G43
DS-416	B,C,D	Cu.	10	27	9118D97G44
DS-416	A	Cu.	15	27	9118D97G46
DS-416	B,C,D	Cu.	15	27	9118D97G47
DSL-416	A	Alum.	10	35	9118D97G49
DSL-416	B,C,D	Alum.	10	35	9118D97G50
DSL-416	A	Alum.	15	35	9118D97G52
DSL-416	B,C,D	Alum.	15	35	9118D97G53
DSL-416	A	Cu.	10	35	9118D97G55
DSL-416	B,C,D	Cu.	10	35	9118D97G56
DSL-416	A	Cu.	15	35	9118D97G58
DSL-416	B,C,D	Cu.	15	35	9118D97G59
DS-416	A	Alum.	10	35	9118D97G61
DS-416	B,C,D	Alum.	10	35	9118D97G62
DS-416	A	Alum.	15	35	9118D97G64
DS-416	B,C,D	Alum.	15	35	9118D97G65
DS-416	A	Cu.	10	35	9118D97G67
DS-416	B,C,D	Cu.	10	35	9118D97G68
DS-416	A	Cu.	15	35	9118D97G70
DS-416	B,C,D	Cu.	15	35	9118D97G71

www.ElectricalPartManuals.com

Replacement Heaters

(These are direct replacements for E. Pgh. S# 3614A50 Series)

Watts	Volts	Style Number
250	125	7497A69H01
250	250	7497A69H02
375	125	7497A69H03
375	250	7497A69H04
95	125	7497A69H04
100	250	7497A69H05



Westinghouse Electric Corporation
Distribution and Control Business Unit
Pittsburgh, PA 15220



May 1980
New Information and
Supplements I.B. 33-790-1E

Low-Voltage Power Circuit Breakers Types DS and DSL

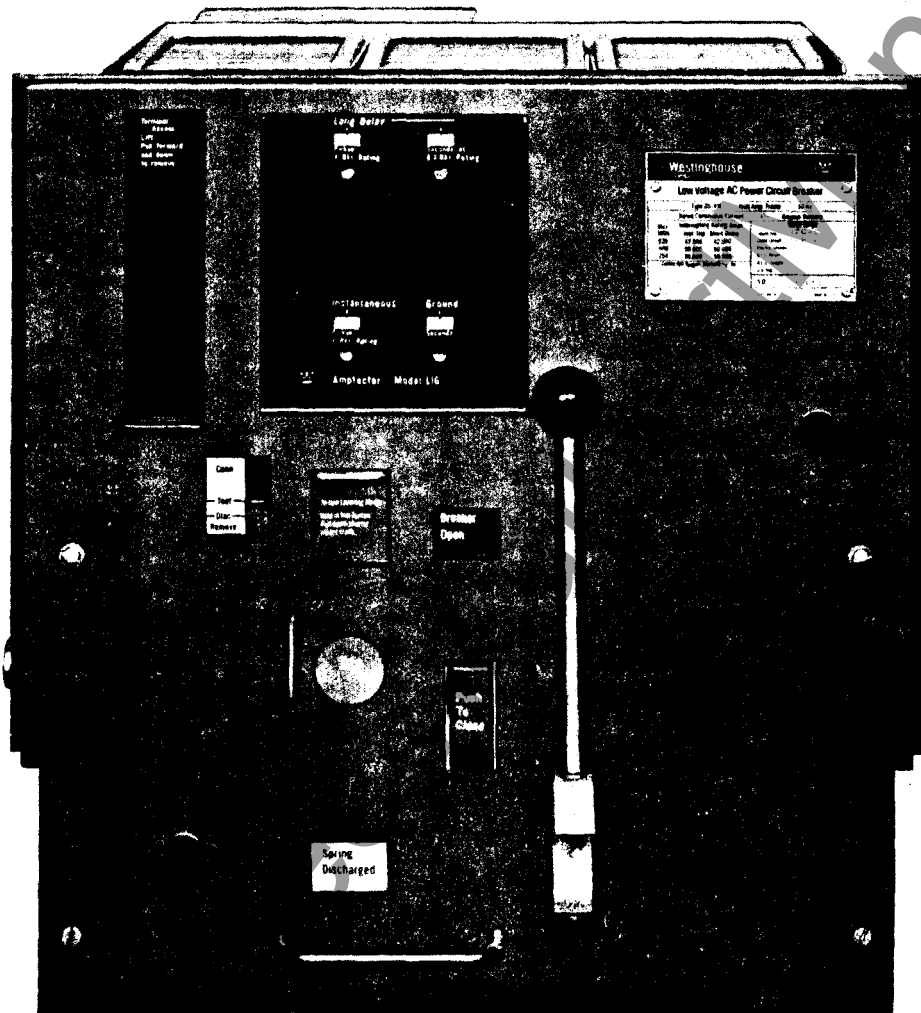

The following breakers are included in
R.P.D. 33-790-1E *

Breaker Type	Frame Size Amperes
DS-206	800
DSL-206	800
DS-206S	800
DS-416	1600
DSL-416	1600
DS-416S	1600
DS-420	2000
DS-632	3200
DS-840	4000

*Data applies to Drawout Breakers only.

INDEX

Subject	Page Number
General Information	2
Common Parts	3
Pole Units	4-7
Arc Chutes & Barriers	8
Levering Mechanism	9
Operating Mechanism	10-12
and Related Parts	
Automatic Tripping System	13
Optional Accessories	14-15
DSL-206 and DSL-416	16

WWW

Parts Identification

Renewal Parts Data 33-790-1E is supplementary information to Instruction Book 33-790-1E, *Instructions for Low Voltage Power Circuit Breakers Types DS and DSL*. The illustrations in this Renewal Parts Data show parts and sub-assemblies which are identified by name and style number in the associated tabulations. Additional information and illustrations are shown in the figures in I.B. 33-790-1E, which show many sub-assemblies and detail parts in order to illustrate their function and location in the assembly. Some of the detail parts shown in the instruction book are recommended only as part of a sub-assembly to facilitate their replacement or installation in the field. The availability of parts and sub-assemblies is indicated by style number in the following data.

If the item in question cannot be identified by style number, refer to the Figure number, name and item number as shown in this RPD (or I.B. 33-790-1E) along with the breaker type and its shop order number or style number as shown on the nameplate on the front cover of the circuit breaker.

The above nameplate information will also be required when adding components, which are not direct replacements, to a circuit breaker.

RECOMMENDED SPARE PARTS

Spare parts recommended for stocking are indicated in the following data by the symbol ®. An adequate stock of spare parts will help minimize emergency situations and can substantially reduce production down time.

The amount of investment to be made in spare parts stock can be dependent on a number of individual factors. The items recommended and the quantities specified below are intended as a guide.

For 1 to 5 Breakers—Items marked ® in sufficient quantity for one breaker.

For 5 to 10 Breakers—Items marked ® in sufficient quantity for two breakers.

Over 10 Breakers—One spare complete breaker, plus recommended spare parts for one breaker.

ORDERING INFORMATION

1. Name item and give its style number. Specify quantity desired.
2. State method of shipment desired.
3. Send all orders or correspondence to nearest Westinghouse Sales Office.

PRICING INFORMATION

Many of the style numbers in this data are listed in Price and Entry Guide 120 and PL 121.

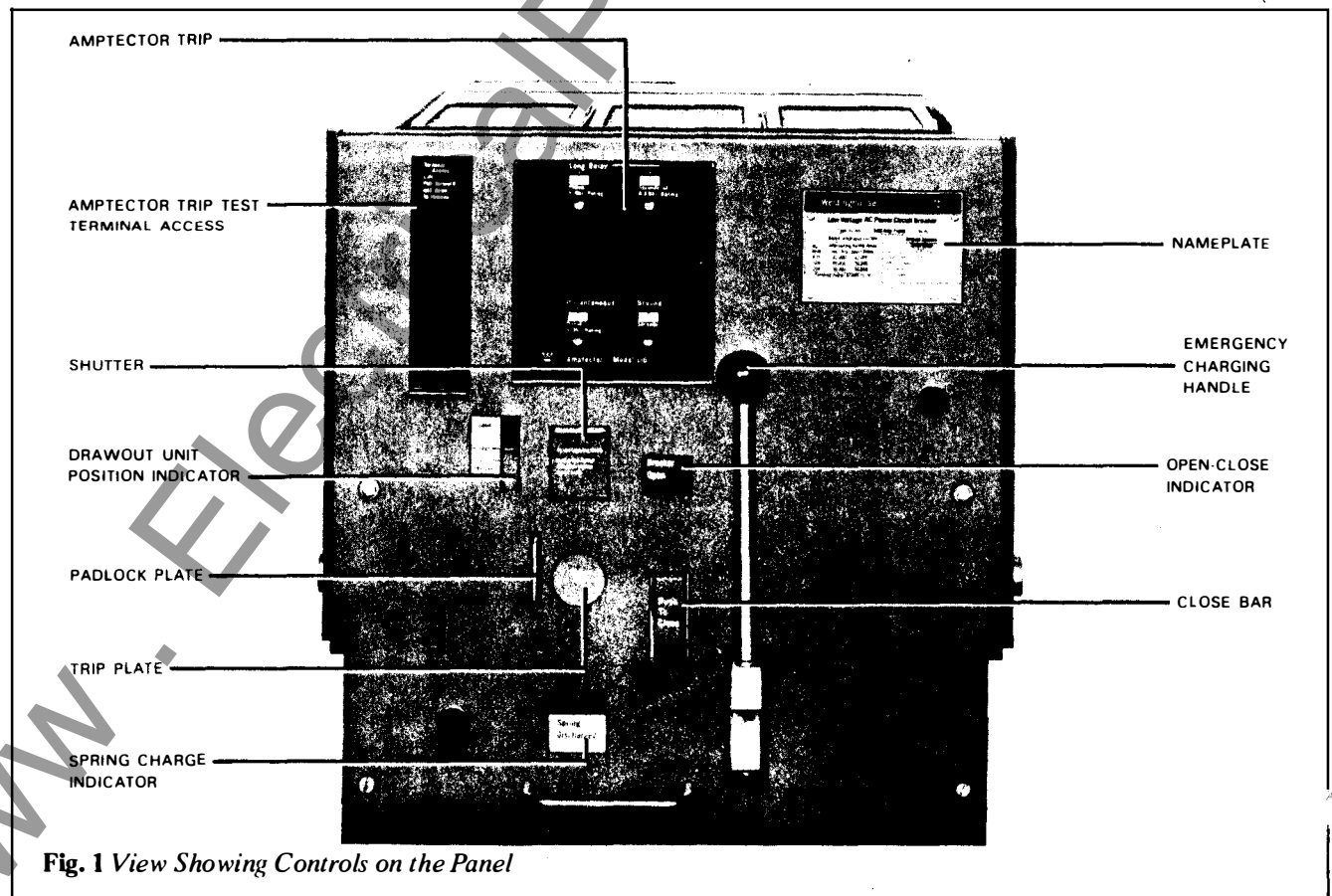

Items Common to All Breaker Types

AUXILIARY SWITCHES—FIGURE NO. 2

When replacing an existing auxiliary switch, order basic switch assembly style 449D622A01 which includes 2 "a" and 2 "b" contacts. Style 449D622A01 is suitable as a replacement on all breakers except those equipped with mechanical interlocks, and those wired per diagram figures 10D, 10E, 10F and 10G.

When adding auxiliary switches to an existing breaker, specify the number of switches required together with the nameplate information as itemized on page 2.

SECONDARY DISCONNECTING CONTACTS—FIGURE NO. 3

When replacing an existing disconnecting contact, order style 591C498G06 which includes an 8 point block plus mounting hardware.

When replacing an existing disconnecting contact cover, order style 588C729G02.

When adding secondary disconnecting contacts to an existing breaker, specify the number of upper contacts and the number of lower contacts together with the nameplate information as itemized on page 2.

TYPE DS CIRCUIT BREAKER FASTENER KIT

Includes an assortment of retaining rings, truarc rings, "E" rings and "X" washers in a plastic bag.

Style 3586A86G01

Recommended spares:

- 1 for one breaker
- 2 for two to five breakers
- 3 for six to twenty breakers
- 4 for over twenty breakers

STANDARD HARDWARE

Standard hardware such as bolts, nuts, washers, etc. are not listed in this data. Such items should be purchased locally. **Note:** Bolts holding copper details together in the pole unit, and bolts holding levering in cranks should be SAE Grade 5.

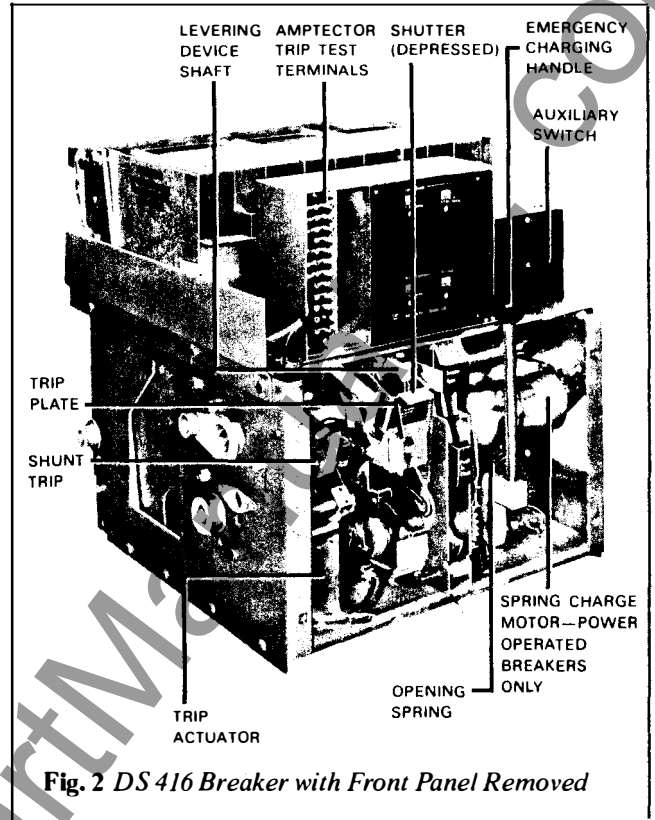

Fig. 2 DS 416 Breaker with Front Panel Removed

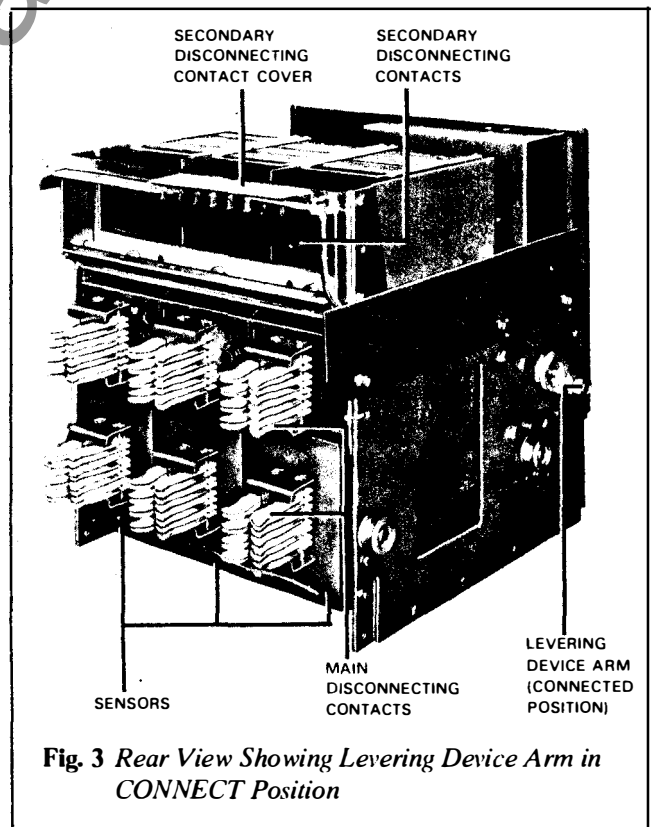

Fig. 3 Rear View Showing Levering Device Arm in CONNECT Position

Type DS-206, DSL-206 and DS-206S Pole Unit

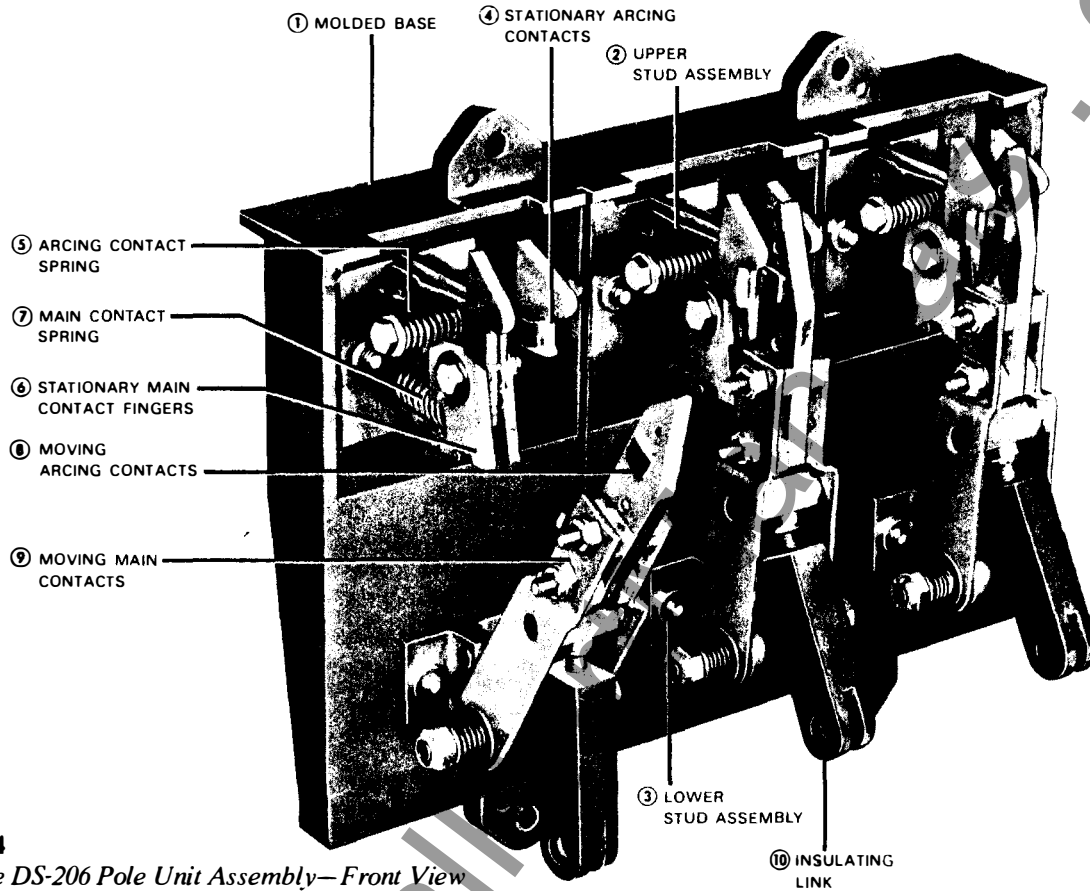

Fig. 4
Type DS-206 Pole Unit Assembly—Front View

Description	Fig. No.	Item No.	DS-206		DSL-206 ⁽¹⁾		DS-206S ⁽²⁾	
			No. Req. Per Bkr.	Style Number	No. Req. Per Bkr.	Style Number	No. Req. Per Bkr.	Style Number
Three Pole Unit Assembly Complete	4	—	1	140D152G01	1	140D152G03	1	9145D41G01
Following are included in Three Pole Unit Assembly:								
Molded Base	4	1	1	140D150H01	1	140D150H01	3	553F204H01
Upper Stud Assembly	4	2	3	591C653G01	3	591C653G03	3	592C928G01
Lower Stud Assembly	4	3	3	591C652G01	3	591C652G03	3	592C927G01
Following are included in Upper Stud Assembly:								
Stationary Arcing Contact—R. H.	4	4	3 ®	503B025G01	3 ®	503B025G01	3 ®	503B025G01
Stationary Arcing Contact—L. H.	4	4	3 ®	503B025G02	3 ®	503B025G02	3 ®	503B025G02
Stationary Arcing Contact Spring	4	5	6 ®	503B027H01	6 ®	503B027H01	6 ®	503B027H01
Stationary Main Contact Finger	4	6	6 ®	809A263G01	6 ®	809A263G01	12 ®	809A263G01
Stationary Main Contact Spring	4	7	3 ®	503B027H08	3 ®	503B027H08	6 ®	503B027H08
Following are included in Lower Stud Assembly:								
Moving Arcing Contact	4	8	3 ®	591C651G02	3 ®	591C651G02	3 ®	591C651G02
Moving Main Contact	4	9	6 ®	591C651G01	6 ®	591C651G01	12 ®	591C651G01
Insulating Link Assembly	4	10	3	788A588G01	3	788A588G01	3	788A588G03
Main Disconnecting Contact Assembly (not included in Pole Unit Assembly)	3	—	6	591C655G02	6	591C655G02	6	591C655G03

® Recommended Spare—See page 2.

(1) See page 16 figure 32 for illustration of the DSL-206.

(2) The DS-206S pole unit is not illustrated. The DS-206S pole unit assembly is similar to the DS-416 with the upper and lower stud assemblies mounted on a separate molded base for each pole rather than a common base for the three poles.

Type DS-416, DSL-416, DS-416S and DS-420 Pole Unit

DS-416 Pole Unit is illustrated. DS-416S and DS-420 Pole Unit Assemblies are similar

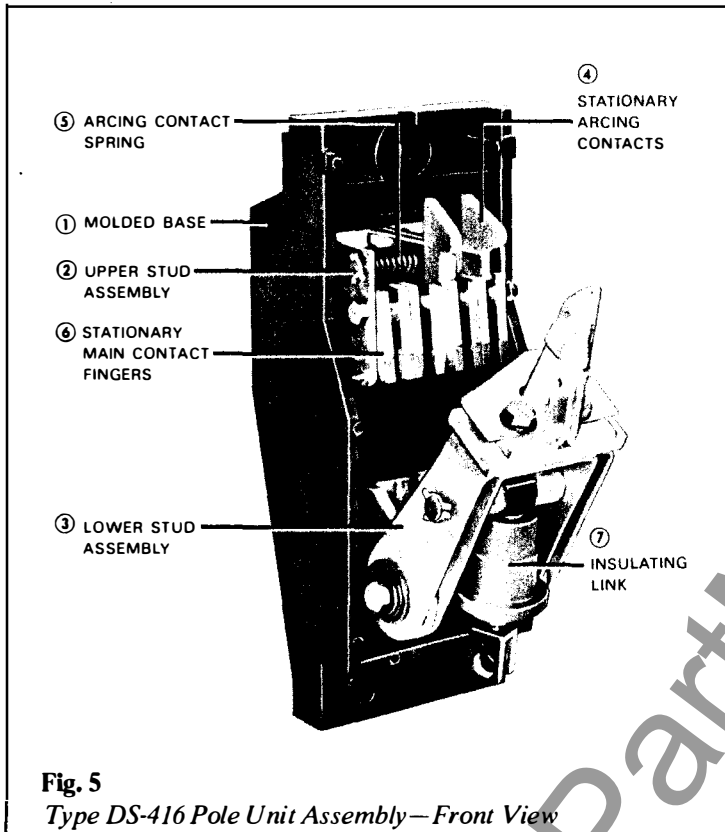

Fig. 5
Type DS-416 Pole Unit Assembly—Front View

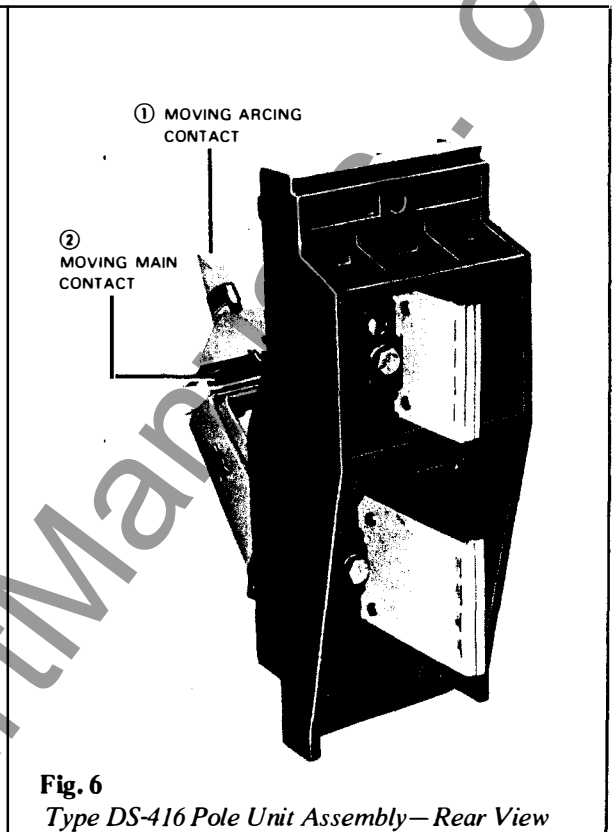

Fig. 6
Type DS-416 Pole Unit Assembly—Rear View

Description	DS-416				DSL-416 ⁽¹⁾		DS-416S and DS-420	
	Fig. No.	Item No.	No. Req. Per Bkr.	Style Number	No. Req. Per Bkr.	Style Number	No. Req. Per Bkr.	Style Number
Single Pole Unit Assembly Complete	5-6	—	3	151D064G01	3	151D065G01	3	151D065G02
Following are included in Single Pole Unit Assembly:								
Molded Base	5	1	3	553F204H01	3	553F204H01	3	553F204H01
Upper Stud Assembly	5	2	3	591C750G02	3 ®	139D635G01	3 ®	139D635G02
Lower Stud Assembly	5	3	3	126D298G06	3	139D633G04	3 ®	139D633G05
Following are included in Upper Stud Assembly:								
Stationary Arcing Contact—R. H.	5	4	3 ®	503B025G01	3 ®	503B025G01	3 ®	503B025G01
Stationary Arcing Contact—L. H.	5	4	3 ®	503B025G02	3 ®	503B025G02	3 ®	503B025G02
Stationary Arcing Contact Spring	5	5	6 ®	503B027H01	6 ®	503B027H01	6 ®	503B027H01
Stationary Main Contact Finger	5	6	24 ®	809A263G01	36 (2)	809A263G01	36 (2)	809A263G01
Stationary Main Contact Spring—Outer			12 ®	503B027H05	12 (2)	503B027H05	12 (2)	503B027H05
Stationary Main Contact Spring—Inner			—		12 (2)	503B027H10	12 (2)	503B027H10
Following are included in Lower Stud Assembly:								
Moving Arcing Contact	6	1	3 ®	503B022G01	3 ®	503B022G01	3 ®	503B022G01
Moving Main Contact	6	2	3 ®	665A321G01	3 ®	795A769G01	3 (3)	795A769G01
Insulating Link Assembly	5	7	3	436B450G02	3	436B450G02	3	436B450G02
Main Disconnecting Contact Assembly (not included in Pole Unit Assembly)	3	—	6	682C347G01	6	682C347G01	6	590C804G01

® Recommended Spare — See page 2.

(1) See page 16 figure 33 for illustration of the DSL-416.

(2) Assembly of the stationary main contact fingers and inner and outer springs is difficult. The Upper Stud Assembly is recommended for the DSL-416, DS-416S and DS-420.

(3) Changing the moving main contact is complicated because of a drilling and pinning operation. The Lower Stud Assembly is recommended for the DS-416S and DS-420.

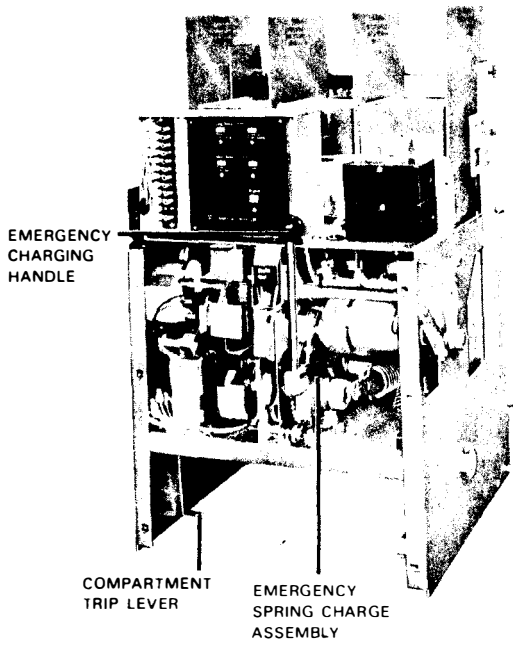

Fig. 7 DS-632 Breaker with Front Panel Removed

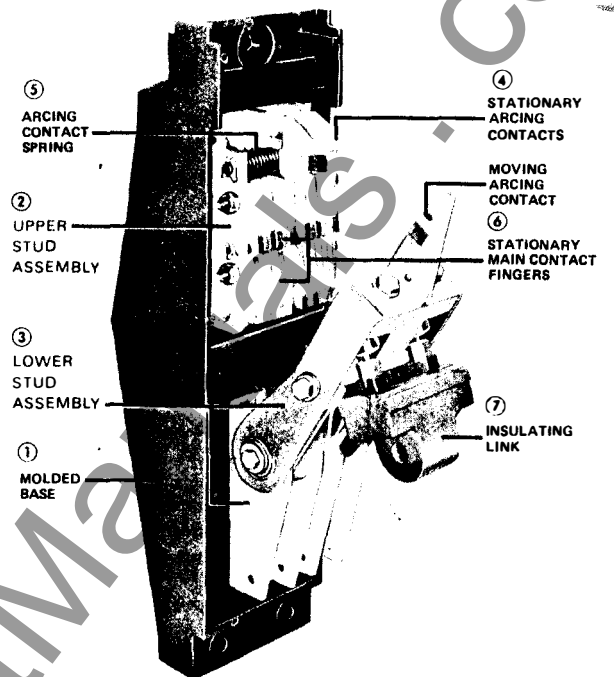

Fig. 8 Type DS-632 Pole Unit Assembly— Front View

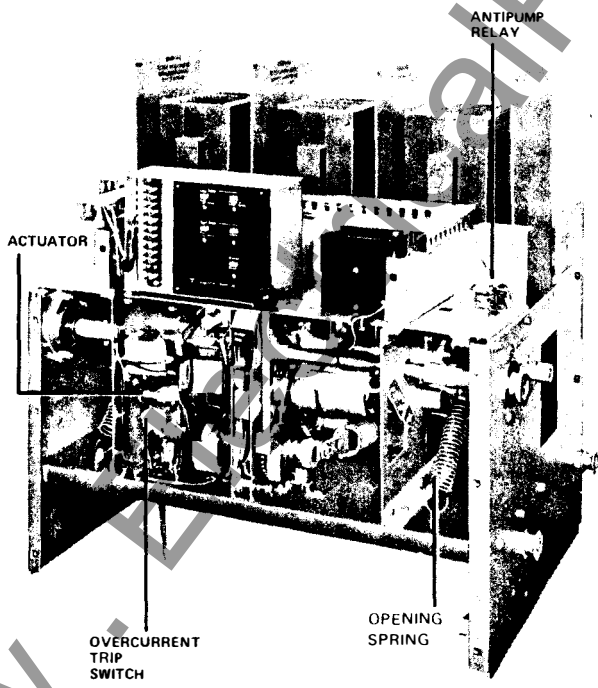

Fig. 10 DS-840 Breaker with Front Panel Removed

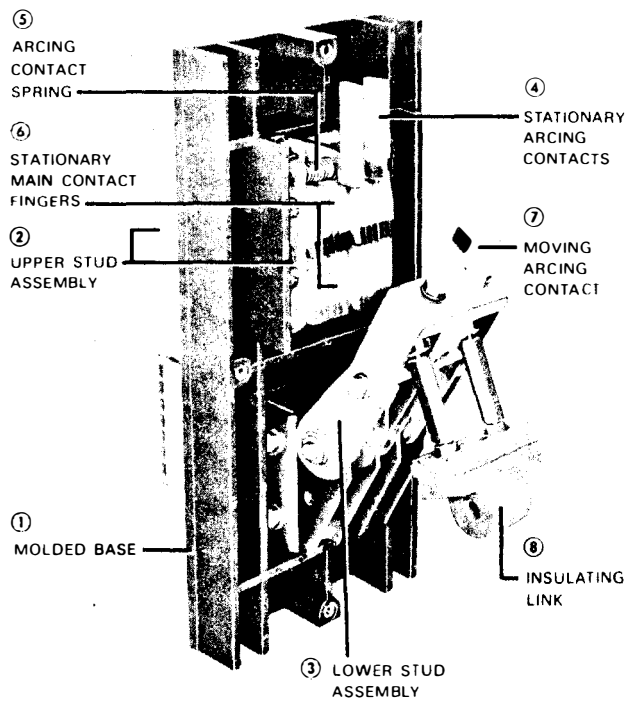

Fig. 11 Type DS-840 Pole Unit Assembly— Front View

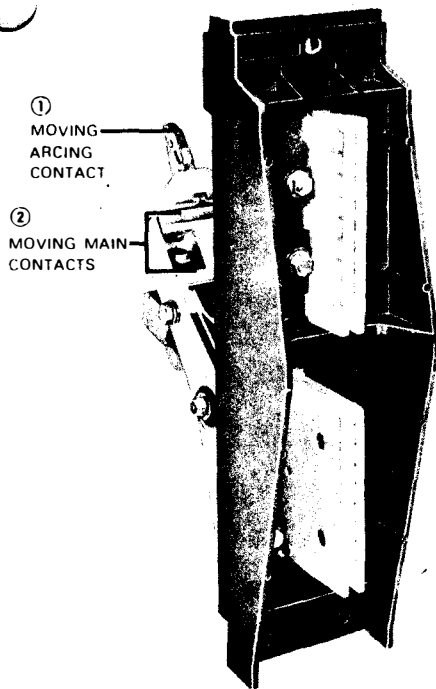

Fig. 9 Type DS-632 Pole Unit Assembly—Rear View

Type DS-632 Pole Unit

Description	Figure Number	Item No.	Number Required Per Bkr.	Style Number
Single Pole Unit Assembly Complete	8-9	—	3	567F962G01
Following are included in Single Pole Unit Assembly:				
Molded Base	8	1	3	553F205H01
Upper Stud Assembly	8	2	3 (®)	126D299G02
Lower Stud Assembly	8	3	3 (®)	140D091G05
Following are included in Upper Stud Assembly:				
Stationary Arcing Contact—R.H.	8	4	3 (®)	588C736G01
Stationary Arcing Contact—L.H.	8	4	3 (®)	588C736G02
Stationary Arcing Contact Spring	8	5	6 (®)	503B027H01
Stationary Main Contact Finger	8	6	72 (1)	809A263G01
Stationary Main Contact Spring—Outer			24 (1)	503B027H05
Stationary Main Contact Spring—Inner			24 (1)	503B027H10
Following are included in Lower Stud Assembly:				
Moving Arcing Contact	9	1	3 (®)	588C735G01
Moving Main Contact	9	2	3 (2)	794A105G01
Insulating Link Assembly	8	7	3	680C792G03
Main Disconnecting Contact Assembly (not included in Pole Unit assembly)	3	—	6	682C347G02

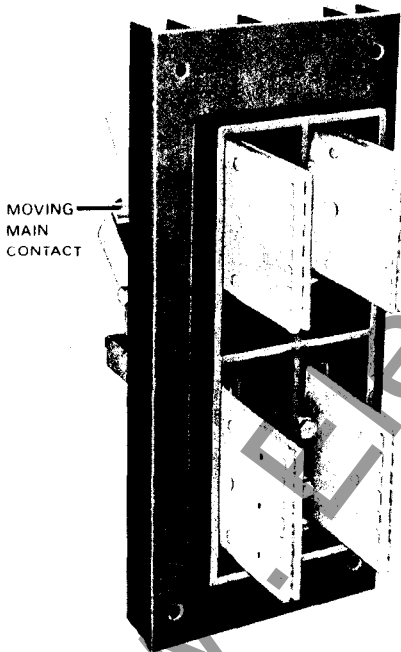

Fig. 12 Type DS-840 Pole Unit Assembly—Rear View

Type DS-840 Pole Unit

Description	Figure Number	Item No.	Number Required Per Bkr.	Style Number
Single Pole Unit Assembly Complete	11-12	—	3	567F991G03
Following are included in Single Pole Unit Assembly:				
Molded Base	11	1	3	567F501G01
Upper Stud Assembly	11	2	3 (®)	140D779G01
Lower Stud Assembly	11	3	3 (®)	140D778G01
Following are included in Upper Stud Assembly:				
Stationary Arcing Contact—R.H.	11	4	3 (®)	588C736G01
Stationary Arcing Contact—L.H.	11	4	3 (®)	588C736G02
Stationary Arcing Contact Spring	11	5	6 (®)	503B027H01
Stationary Main Contact Finger	11	6	72 (1)	809A263G01
Stationary Main Contact Spring—Outer			24 (1)	503B027H05
Stationary Main Contact Spring—Inner			24 (1)	503B027H10
Following are included in Lower Stud Assembly:				
Moving Arcing Contact	11	7	3 (®)	588C735G01
Moving Main Contact	12	—	3 (2)	794A105G01
Insulating Link Assembly	11	8	3	680C792G04
Main Disconnecting Contact Assembly (not included in Pole Unit assembly).	3	—	12	591C100G01

(®) Recommended Spare—See page 2.

(1) Assembly of the stationary main contact fingers and inner and outer springs is difficult. The Upper Stud Assembly is recommended.

(2) Assembly of the moving main contact is difficult. The Lower Stud Assembly is recommended.

Arc Chutes and Barriers

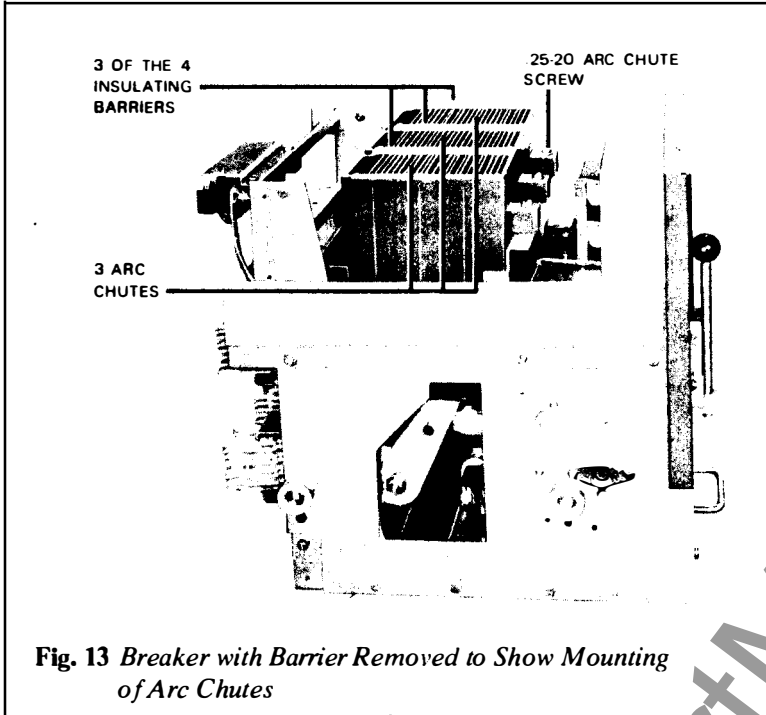

Fig. 13 Breaker with Barrier Removed to Show Mounting of Arc Chutes

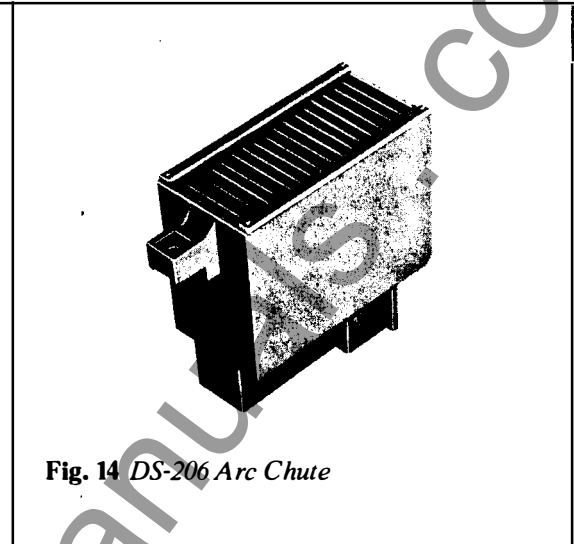

Fig. 14 DS-206 Arc Chute

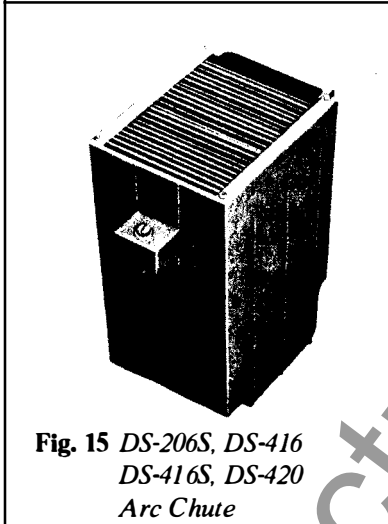

Fig. 15 DS-206S, DS-416, DS-416S, DS-420 Arc Chute

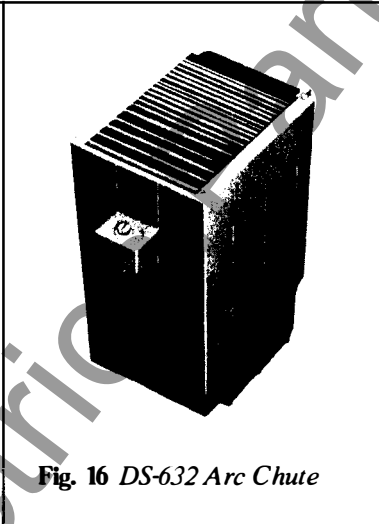

Fig. 16 DS-632 Arc Chute

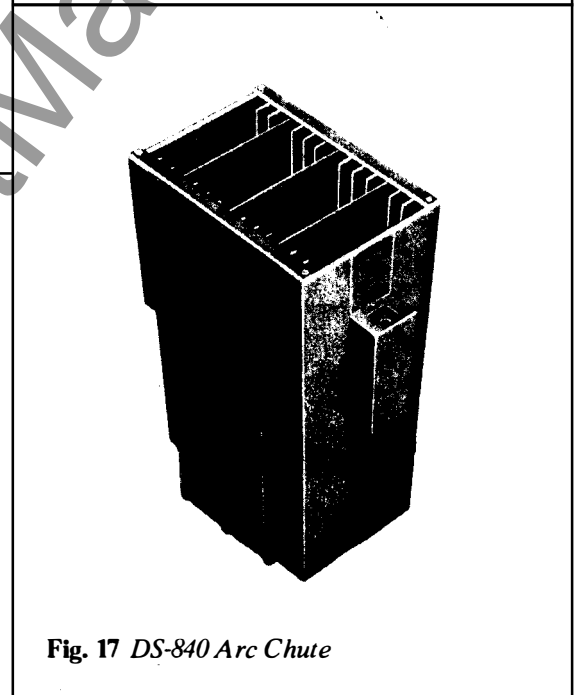

Fig. 17 DS-840 Arc Chute

		Assembled Arc Chute and Mounting Screw		Removable Insulating Barriers — Fig. 13			
				Outer		Inner	
Breaker Type	Figure Number	Number Required Per Breaker	Style Number	Number Required Per Breaker	Style Number	Number Required Per Breaker	Style Number
DS-206 DSL-206	14	3	449D508G01	2	349A578H01	2	788A586H01
DS-206S DS-416 DSL-416 DS-416S DS-420	15	3	151D018G01	2	349A578H01	2	349A578H01
DS-632	16	3	151D018G02	2	436B108H02	2	436B108H01
DS-840	17	3	140D164G01	2	803A735H01	2	803A735H01

Levering Mechanism

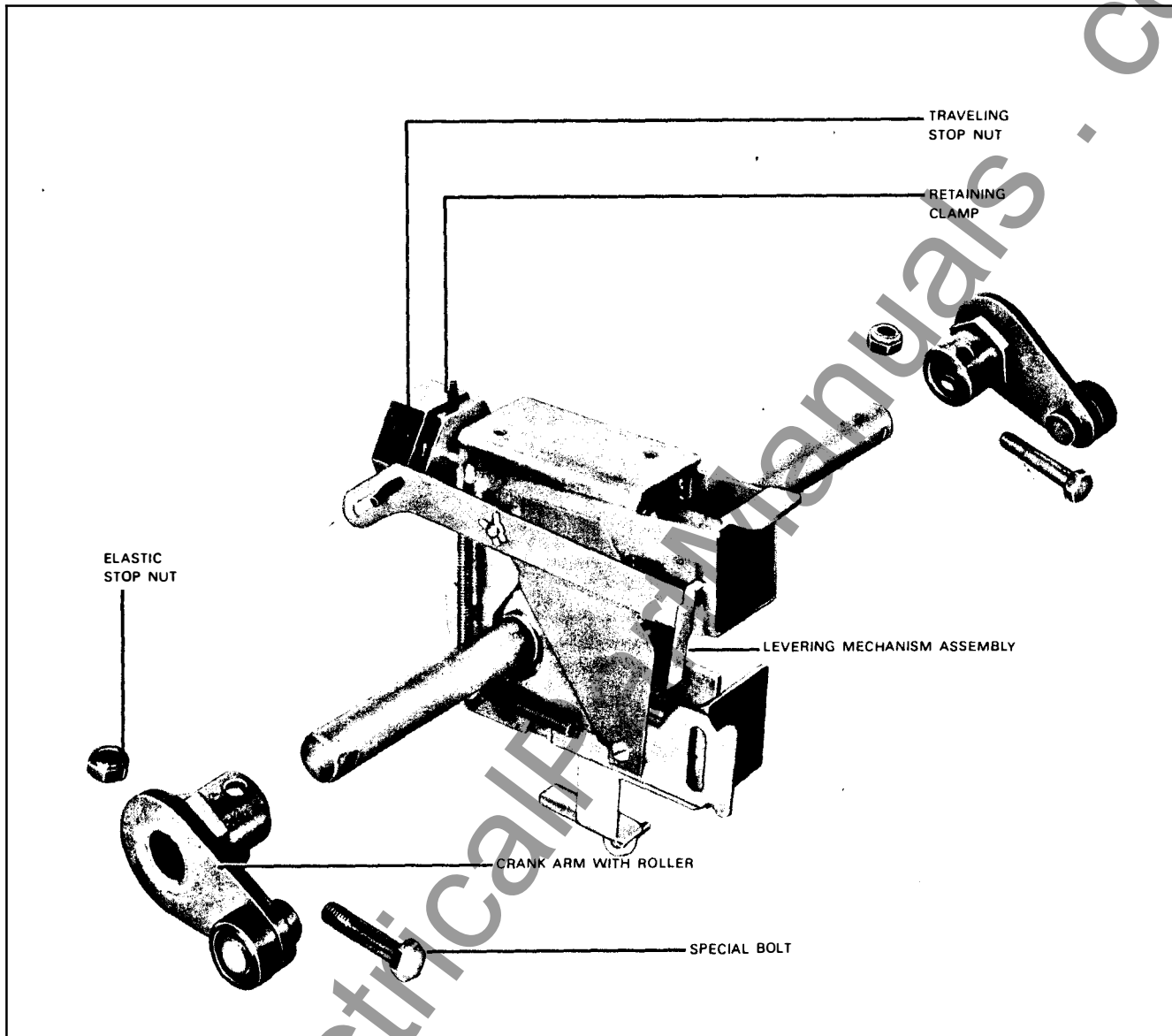

Fig. 18 Levering Mechanism

Levering Mechanism — Fig. 18

Description	Number Required per Breaker	All Type DS/DSL except DS-840	DS-840
		Style Number	Style Number
Levering Mechanism Assembly	1	449D224G04	449D224G05
Following are included in Assembly:			
Traveling Stop Nut	1	791A674H01	791A674H01
Retaining Clamp	1	791A679H01	791A679H01
Following are not included in Assembly:			
Crank Arm with Roller	2	786A586G01	567F993G02
Special Bolt	2 (1)	794A024H01	794A024H01 (1)
Elastic Stop Nut	2 (1)	70220ERN18	70220ERN18 (1)

(1) For DS-840 four are required per breaker.

Mechanism and Related Parts

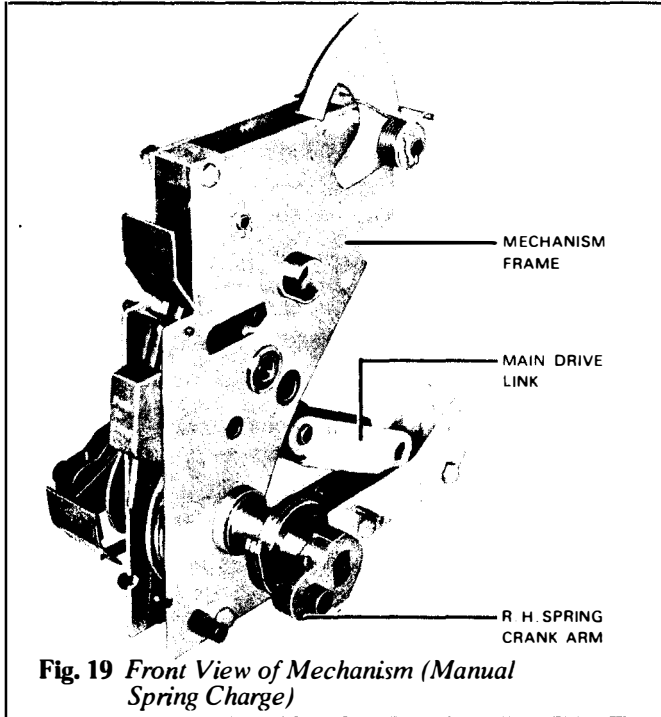

Fig. 19 Front View of Mechanism (Manual Spring Charge)

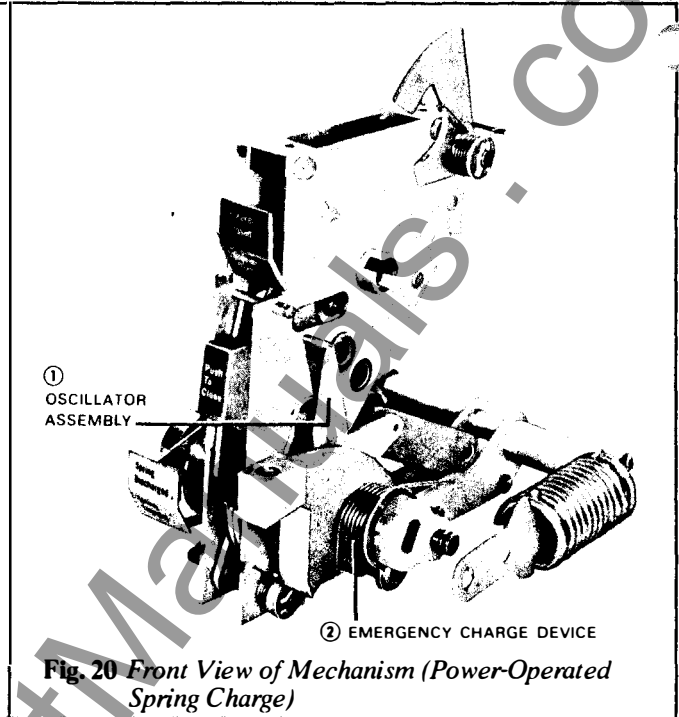

Fig. 20 Front View of Mechanism (Power-Operated Spring Charge)

All DS/DSL except DS-632 and DS-840

Description	Power Operated				Manual Operated		
	Number Required per Breaker	Fig. No.	Item No.	Style Number	Fig. No.	Item No.	Style Number
Mechanism Assembly (Without Closing Spring) Following are included in Mechanism Assembly:	1	20	—	567F759G02	19	—	567F759G01
Main Drive Link Ass'y. (With Roller)	1	21	1-2	4378146G03	21	1-2	4378146G03
Oscillator Ass'y.	1	20	1	4368923G01			.
Oscillator Reset Spring (Not Illustrated)	1	—	—	® 5038601H11			.
Emergency Charge Device	1	20	2	4368925G01			.
Spring Release Latch (With Bearings)	1	22	1	795A855G01	22	1	795A855G01
Trip Latch	1	22	2	3755A19G01	22	2	3755A19G01
Lever (for motor cut-off switch)	1	22	3	791A516H01	22	3	791A516H01
Trip Latch Reset Spring	1	22	4	® 795A077H01	22	4	® 795A077H01
Following are not included in Mechanism Assembly:							
Manual Charge Ass'y. (Without Handle)	1			.	23	8	591C385G01
Manual Charge Handle	1			.	23	9	349A669G02
Emergency Charge Handle	1	2	—	349A669G04			.
Trip Shaft	1	23	2	788A502H01	23	2	788A502H01
Trip Shaft Lever	1	23	3	4378381H01	23	3	4378381H01
Trip Shaft Return Spring	1	23	4	® 4368621H05	23	4	® 4368621H05
Opening Spring	1	2	—	® 5038601H04	2	—	® 5038601H04
Motor, incl. Crank & Connectors	1	23	10	® See Page 12			.
Closing Spring Ass'y.	2	21	3-4		21	3-4	
DS-206				349A521G01			349A521G01
DS-206S							
DS-416				791A671G02			791A671G02
DS-416S							
DS-420				791A671G01			791A671G01

® Recommended Spare -- See page 2. *Not Required

Mechanism and Related Parts

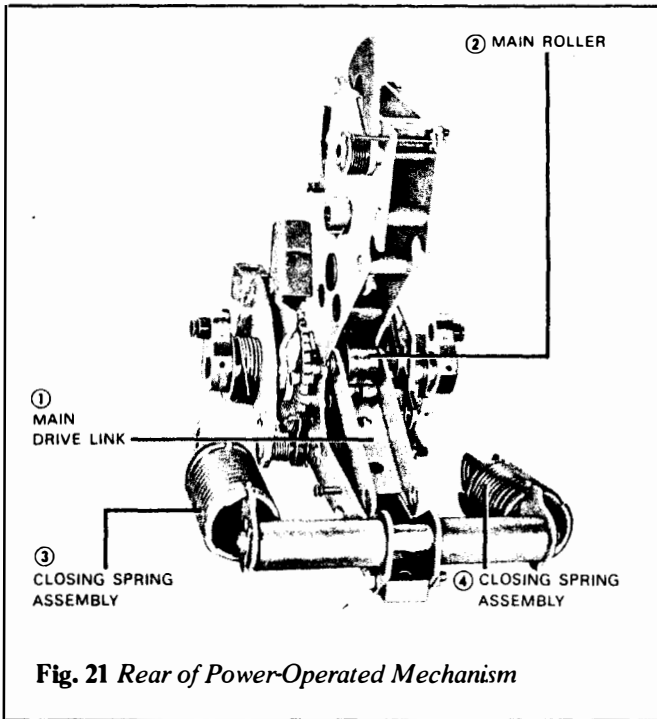

Fig. 21 Rear of Power-Operated Mechanism

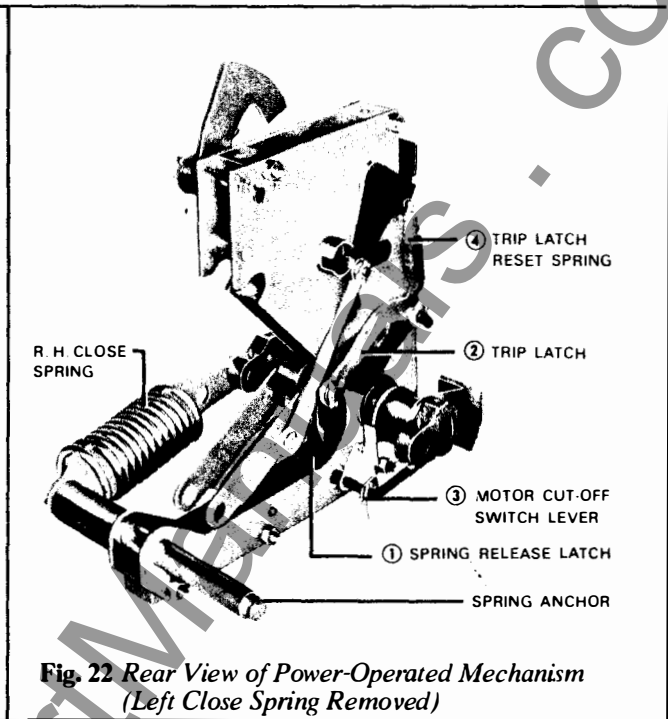

Fig. 22 Rear View of Power-Operated Mechanism (Left Close Spring Removed)

DS-632 and DS-840

Description	Power Operated				Manual Operated		
	Number Required per Breaker	(1) Fig. No.	Item No.	Style Number	(1) Fig. No.	Item No.	Style Number
Mechanism Assembly (Without Closing Spring)	1	20	—	567F759G04	19	—	567F759G07
Following are included in Mechanism Assembly:							
Main Drive Link Ass'y. (With Roller)	1	21	1-2	437B146G04	21	1-2	437B146G04
Oscillator Ass'y.	1	20	1	436B923G01			•
Oscillator Reset Spring (Not Illustrated)	1		—	® 503B601H11			•
Emergency Charge Device	1	20	2	436B925G01			•
Spring Release Latch (With Bearings)	1	22	1	795A855G01	22	1	795A855G01
Trip Latch	1	22	2	3755A19G01	22	2	3755A19G01
Lever (for motor cut-off switch)	1	22	3	791A516H01	22	3	791A516H01
Trip Latch Reset Spring	1	22	4	® 795A077H01	22	4	® 795A077H01
Following are not included in Mechanism Assembly:							
Manual Charge Ass'y. (Without Handle)	1			•	23	8	591C385G01
Manual Charge Handle	1			•	23	9	349A669G02
Emergency Charge Handle	1	7	—	349A669G04			•
Trip Shaft	1	23	2	788A502H01	23	2	788A502H01
Trip Shaft Lever	1	23	3	437B381H01	23	3	437B381H01
Trip Shaft Return Spring	1	23	4	® 436B621H05	23	4	® 436B621H05
Opening Spring	1 (2)	8	—	® 503B601H04	8	—	® 503B601H04
Motor, incl. Crank & Connectors	1	23	10	® See Page 12			•
Closing Spring Ass'y.	2	21	3-4	791A671G03	21	3-4	791A671G03

® Recommended Spare—See page 2. *Not Required.

(1) Figures 19 thru 22 illustrate mechanism for all DS/DSL breakers except DS-632 and DS-840. DS-632 and DS-840 mechanisms are similar.

(2) Two opening springs are required for DS-840.

Mechanism and Related Parts

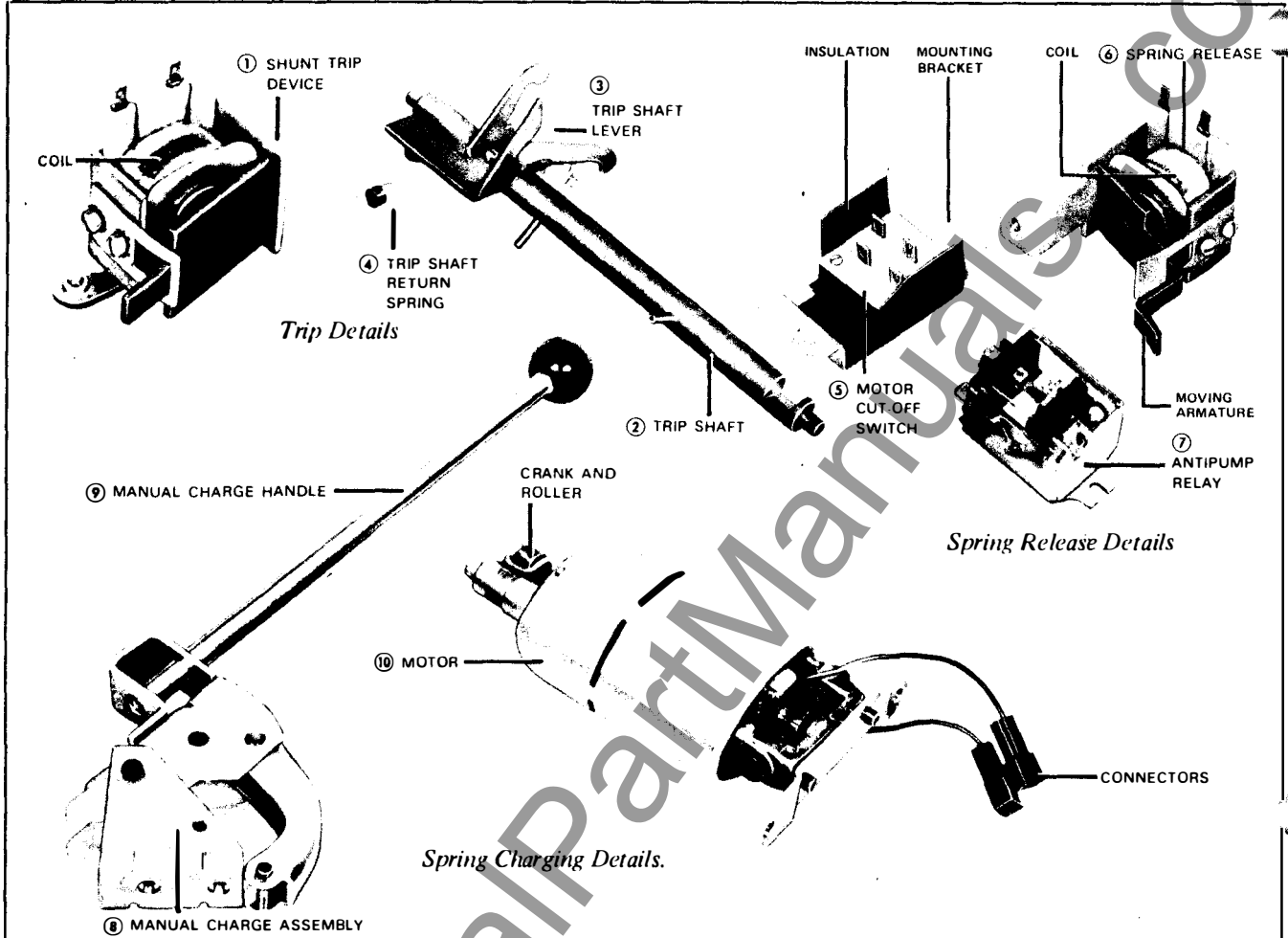

Fig. 23 Trip, Spring Release, and Spring Charging Details

Voltage	Shunt Trip (1) Fig. No. 23 Item No. 1		Spring Release (1) Fig. No. 23 Item No. 6		® Anti-Pump Relay Fig. No. 23 Item No. 7	® Motor Kit (4) Fig. No. 23 Item No. 10
	Complete Assembly		Complete Assembly			
	DS/DSL except DS-840 (2)	Coil ® Only	DS/DSL except DS-840 (3)	Coil ® Only		
24 DC	3752A02G01	151D786G01	—	—	—	—
32 DC	3752A02G02	151D786G03	—	—	—	—
48 DC	3752A02G03	151D786G04	3752A03G01	151D786G04	140D930H03	449D431G03
125 DC	3752A02G04	151D786G08	3752A03G02	151D786G08	140D930H04	449D431G01
250 DC	3752A02G05	151D786G11	3752A03G03	151D786G11	140D930G05	449D431G02
120 60 HZ	3752A02G06	151D786G04	3752A03G04	151D786G02	140D930H01	449D431G01
240 60 HZ	3752A02G07	151D786G08	3752A03G05	151D786G05	140D930H02	449D431G02
For Use with Capacitor Trip	3752A02G08	151D786G08	—	—	—	—

® Motor Cut-off Switch—All breakers—Style 450D818G02 Fig. 23—Item 5.

® Recommended Spare—See page 2.

(2) For DS-840 use corresponding groups of 3752A22.

(1) Shunt Trip and Spring Release complete assembly includes mounting hardware and wire leads for field replacement. When adding shunt trip or spring release to manual breakers, an auxiliary switch, secondary contacts, and possibly other components will be required.

(3) For DS-840 use corresponding groups of 3752A23.

(4) Motor Kit includes crank and roller and connectors for field replacement.

Type DS Circuit Breaker Automatic Tripping System

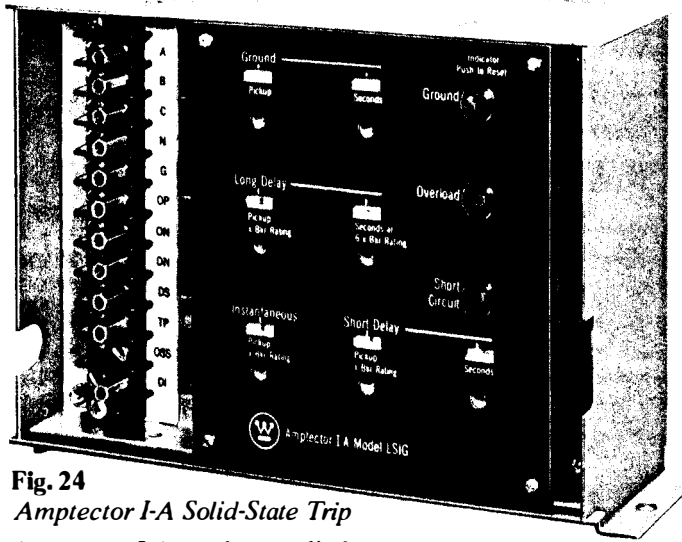

Fig. 24

Amptector I-A Solid-State Trip

Amptector I-A can be supplied in various combinations of four independent continuously adjustable overcurrent tripping functions:

Long delay (L), Short delay (S), Instantaneous (I), Ground (G)

The following combinations are available:

LI, LIG, LS, LSG, LSI, LSIG

Model	Style Number — 60 HZ
LI	6998D02G01
LIG	6998D02G02 (1)
LS	6998D02G03
LSG	6998D02G04 (1)
LSIG	6998D02G05 (1)
LSI	6998D02G06

(1) For DS-632 and DS-840 use Groups 62, 64, 65 and 82, 84, 85 respectively.

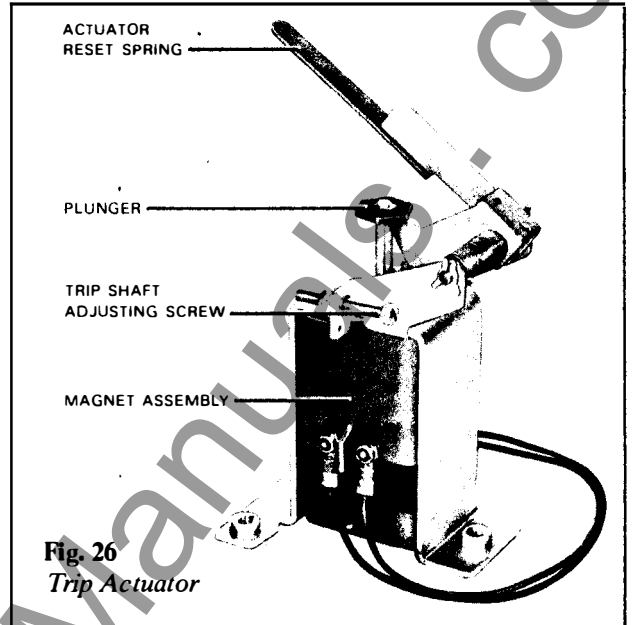

Fig. 26

Trip Actuator

DIRECT TRIP ACTUATOR FIGURE NO. 26

All type DS Breakers use Style Number 592C114G03 (with Black Magnet Ass'y)

Exception: If a breaker is equipped with an earlier Amptector II Style 151D792G series, use actuator style 592C114G01 (with Red Magnet Ass'y).

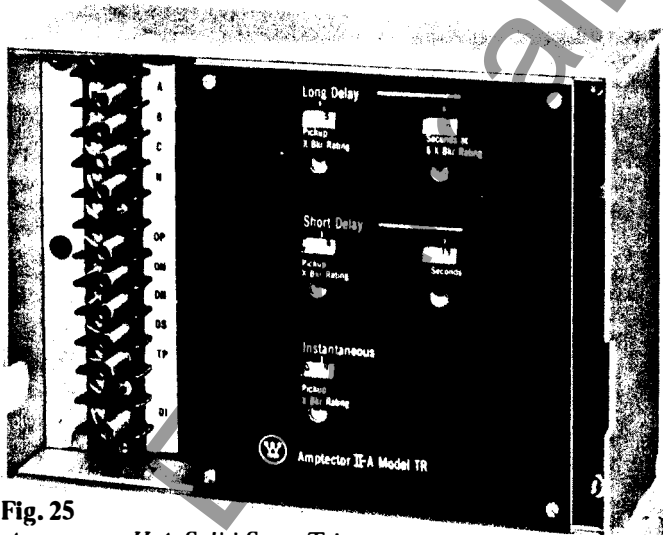

Fig. 25

Amptector II-A Solid-State Trip

Amptector II-A can be supplied in three models or combinations of three independent continuously adjustable overcurrent tripping functions: long delay, short delay and instantaneous.

These models are:

DU(Dual—Long delay and instantaneous

SE(Selective)—Long delay and short delay

TR(Triple)—Long delay, short delay and instantaneous

Model	Style Number — 60 HZ
DU	6997D20G41
SE	6997D20G42
TR	6997D20G43

SENSORS

See Figure 3 for Typical Sensors

Refer to I.B. 33-790-1E, Table 4, for application of sensors.

Sensor Rating Amperes	Sensor Style Number
50	794A170G01
100	151D995G01
150	151D995G15
200	151D995G02
300	151D995G03
400	151D995G04
600	151D995G06
800	151D995G08
1200	151D995G12
1600	151D995G16
2000	151D995G20
2400	151D995G24
3200	151D995G32
4000	588C734G01

NOTE:

For information on application and operation of the automatic tripping system refer to Section 8 of Instruction Book 33-790-1E.

Optional Accessories

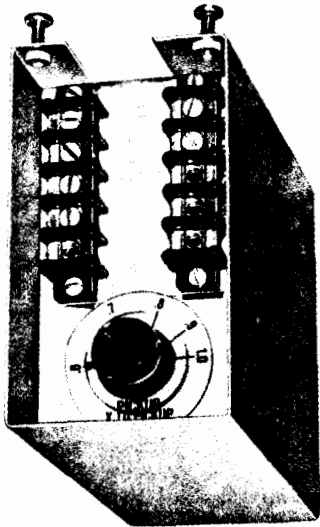

Fig. 27 High Load Switch—Style 151D006G04

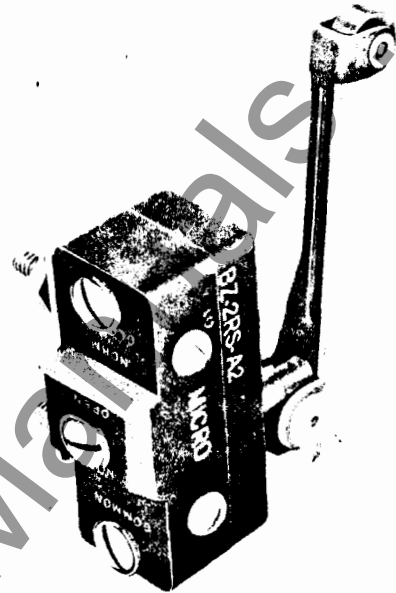

Fig. 28 Latch Check Switch—Style 140D161G01

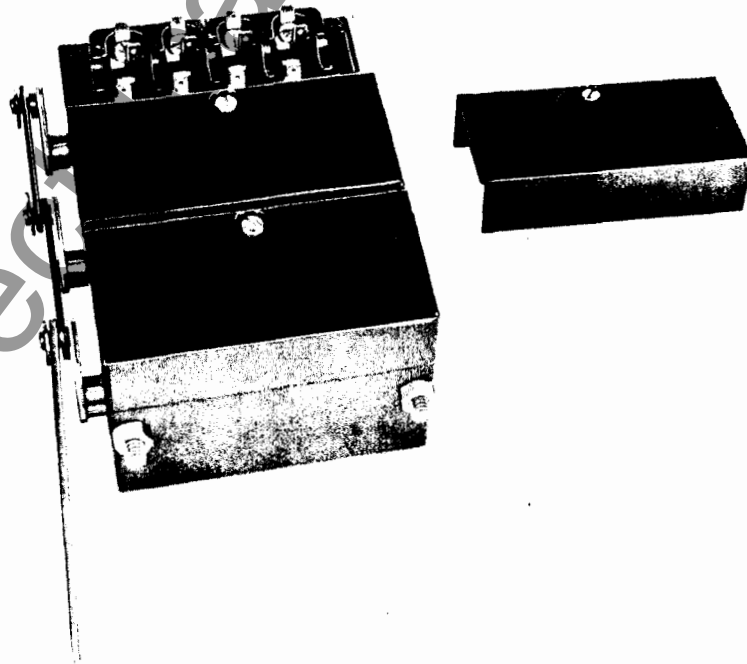

Fig. 29 Auxiliary Switches—See page 3 for identification of auxiliary switches.

Optional Accessories

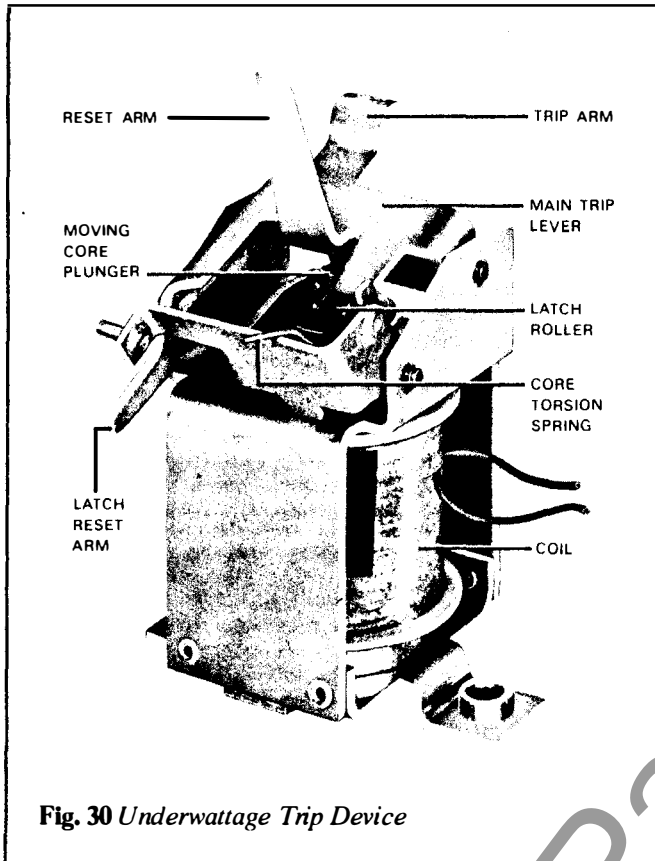

Fig. 30 Underwattage Trip Device

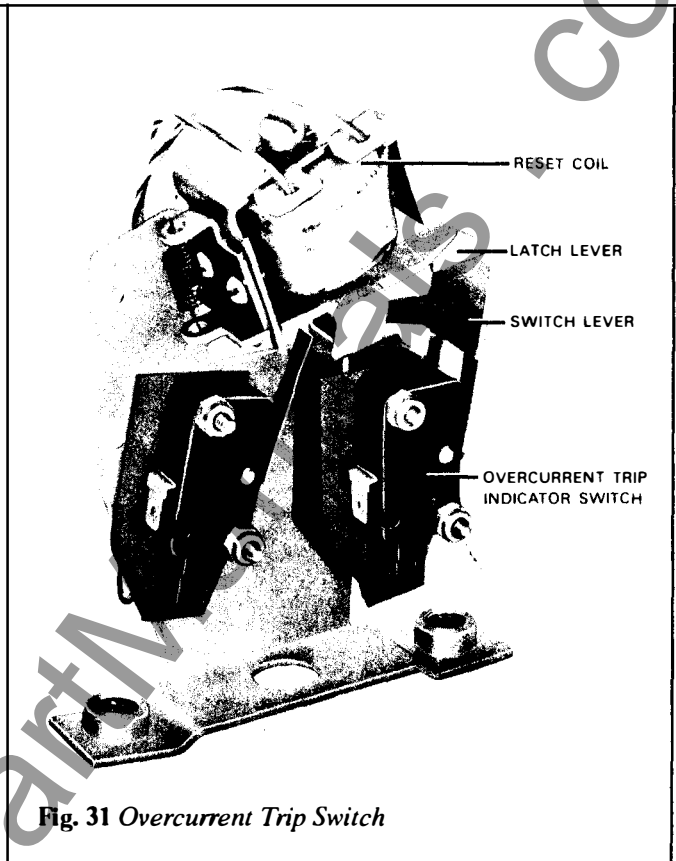

Fig. 31 Overcurrent Trip Switch

UNDervOLTAGE TRIP DEVICE—FIGURE NO. 30		
Voltage	Undervoltage-Instantaneous	Undervoltage-Time Delay
	All DS/DSL Except DS-840 (1)	All DS/DSL Except DS-840 (2)
120 60 HZ	3752A05G01	3752A06G01
208 60 HZ	3752A05G02	3752A06G02
240 60 HZ	3752A05G03	3752A06G03
460 60 HZ	3752A05G04	3752A06G04
48 DC	3752A05G05	3752A06G05
125 DC	3752A05G06	3752A06G06
250 DC	3752A05G07	3752A06G07
(1) For DS-840 use corresponding groups of 3752A25		
(2) For DS-840 use corresponding groups of 3752A26		
Special Voltage	All DS/DSL including DS-840	All DS/DSL including DS-840
24 DC	3752A45G01	3752A46G01
115 50 HZ	3752A45G02	3752A46G02
208 50 HZ	3752A45G03	3752A46G03
230 50 HZ	3752A45G04	3752A46G04
400/50 HZ	3752A45G05	3752A46G05
415	3752A45G06	3752A46G06

NOTES
 All styles include mounting hardware and wire leads for field replacement. When adding to existing breakers, secondary contacts will be required.

The undervoltage trip device is available as a complete assembly. The coil only is not recommended as it is riveted into the assembly.

OVERCURRENT TRIP SWITCH—FIGURE NO. 31			
For all type DS/DSL except DS-840 (1).			
Manual Reset			
2 Contact		3 Contact	4 Contact
3752A04G01		3752A04G02	3752A04G03
Electrical Reset			
Voltage	2 Contact	3 Contact	
48 DC	3752A04G04	3752A04G09	
115 AC	3752A04G05	3752A04G10	
125 DC	3752A04G06	3752A04G11	
230 AC	3752A04G07	3752A04G12	
250 DC	3752A04G08	3752A04G13	

(1) For DS-840 use corresponding groups of 3752A24.

All styles include mounting hardware and wire leads for field replacement. When adding to existing breakers other components may be needed.

For replacement of switches only order style 6898D52A01 which consists of two switches, a switch bracket and rivets.

DSL-206 and DSL-416 Breakers

Parts for pole units, arc chutes, mechanisms, etc. for DSL breakers are identified on preceding pages of this R.P.D.

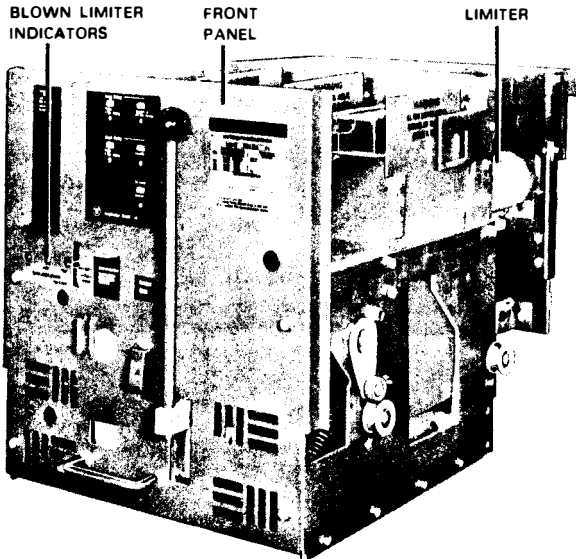

Description	Fig. No.	Number Required per Breaker	DSL-206 and DSL-416 Style Number
Blown Limiter Indicator Ass'y.	32	1	140D777G01
Isolating Transformer Ass'y. (includes 3 transformers)	33	1	591C755G01
Transformer Only:	33	3	795A823H01

Fig. 32 DSL-206 Breaker—Front View

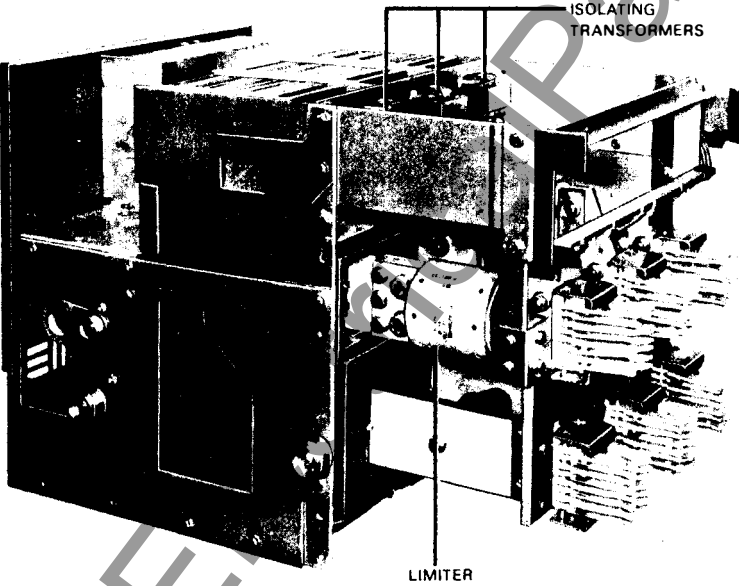

® LIMITERS—FIGURES 32-33
Refer to I.B. 33-790-1E, Table 5, for application of limiters.

Breaker Type	Number Required per Breaker	Rating Amps	Style Number
DSL-206	3	150	140D316G01
	3	200	140D316G02
	3	250	140D316G03
	3	300	140D316G04
	3	400	140D316G05
	3	600	140D316G06
	3	800	140D316G07
	3	1200	140D316G10
	3	1600	140D316G11
DSL-416	3	2000	140D316G12
	3	800	151D932G01
	3	1000	151D932G02
	3	1200	151D932G03
	3	1600	151D932G04
	3	2000	151D932G05
	3	2500	151D932G09
3	3000	151D932G10	

® Recommend 3 spare limiters of each current rating.

Fig. 33 DSL-416 Breaker—Side View