

Westinghouse

TYPE 60 CARRIER CURRENT
TRANSMITTER-RECEIVER

FOR INDOOR MOUNTING

50 - 150 Kilocycles
100 - 150 Volts d-c. Input
or
200 - 300 Volts d-c. Input

INSTRUCTIONS

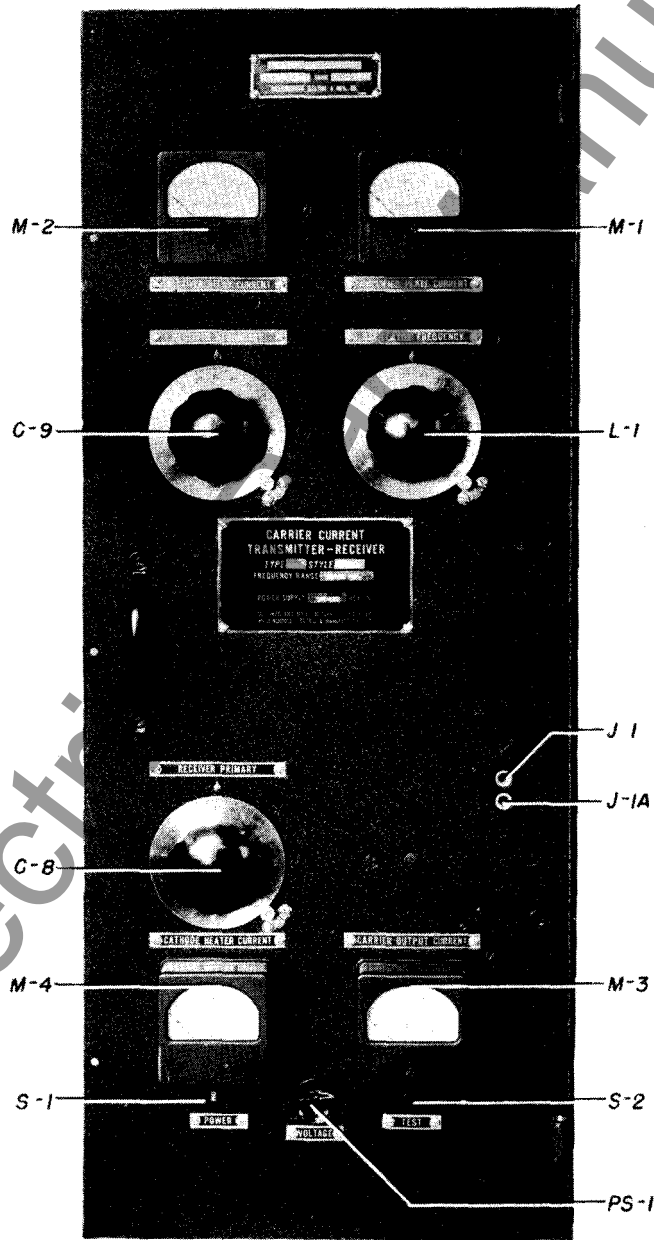

FIGURE 1 FRONT VIEW OF TRANSMITTER-RECEIVER (CABINET DOOR REMOVED)

Westinghouse Electric & Manufacturing Company
Meter Division, Newark, N. J.

APPLICATION

The type GO transmitter-receiver was designed primarily for carrier current relay operation. The relay circuits are arranged so that carrier is transmitted over a line section to prevent the tripping of breakers on external faults. All the carrier equipments on a single line section operate at the same carrier frequency so that when any one or more transmitters are energized, all of the receivers respond.

Besides relaying, the carrier channel may also be used for one other of the following services: telemetering and automatic load control, remote tripping, supervisory control, or voice communication. The connections of the additional equipment required for these services are such that the carrier relays always have control of the channel. The carrier sets are equipped with a plug jack outlet into which a telephone hand set may be plugged for point-to-point voice communication.

CONSTRUCTION AND OPERATION

The type GO carrier transmitter-receiver components are mounted on a vertical panel (figures 1 and 2) are housed in a weather-proof cabinet for outdoor mounting. The sets are identified as follows:

Style #867499 for 100-150 volt d-c. power supply
Style #867500 for 200-300 volt d-c. power supply

These sets contain all the component parts necessary for converting d-c. power into carrier frequency power (50 to 150 kilocycles) for transmission, and also for converting received carrier frequency power into d-c. for relay operation. The transmitter-receiver unit weighs approximately 95 pounds.

The vertical panel is approximately 12 x 32 inches and is hung by trunnions on the right-hand side. It may be swung open or completely removed from the cabinet as desired. Looking at the front of the panel the various instruments and dials are identified by individual name plates and on figure 1 by numbers which designate the component parts in the wiring diagram, figure 3, and throughout the text.

Two shelves extend from the rear of the vertical panel, one near the top and the other near the bottom. A shield panel connects the two shelves and separates the transmitter section on the left side of the panel, figure 2, from the receiver section on the right side of the panel. The location of the various components mounted on the rear of the panels are shown in figure 2. The arrangement of parts provides good heat distribution and accessibility as well as the necessary electrical shielding.

A complete discussion of the operation of vacuum tubes in the transmitter-receiver circuits is beyond the scope of this book and the reader is invited to consult one of the many radio text books if a discussion of the principles involved is desired. Those who are sufficiently interested to pursue such a study will find that the circuits involved in this transmitter-receiver are conventional and that so far as possible they have been simplified by the omission of all unnecessary components. The Colpitts oscillator circuit is so proportioned that one-half of the high frequency voltage output from the plate of the tube is coupled back to the grid for excitation purposes. Since there is no d-c. bias voltage applied to the oscillator tube under transmission conditions, an appreciable amount of grid current flows while this tube is oscillating. However, the same

grid excitation voltage applied to the amplifier tubes causes a negligible amount of grid current because of the fixed d-c. bias provided. The amplifier tubes are, therefore operating in the mode described as Class A operation. It is not necessary for the users of this equipment to be thoroughly familiar with the operation of this circuit, but such a knowledge will aid in securing the best possible operation. Those principles which it is considered essential that the user understand are described in the appropriate section of this book.

The type GO transmitter-receiver connections are shown schematically in figure 3. A single oscillator tube V1 is used to generate carrier frequency voltage which is amplified either by two tubes V3 and V4 in the push-pull circuit, or if desired, by six tubes V3 to V8 in a push-pull parallel connection. The receiver circuit utilizes a single vacuum tube V2. The oscillator tube operates in conjunction with the frequency determining circuits L1, C1, C2 and C3. Direct current grid and plate voltages are supplied through resistor R15 and reactor L3. Capacitor C4 is used to prevent short-circuiting these voltages. The carrier frequency voltages across capacitors C1 and C2 are equal, but of opposite phase, and are applied to the grids of the amplifier tubes through capacitors C5 and C6. The necessary d-c. bias voltage for these grids is supplied through resistors R4 and R5. The sole purpose of resistors R8 to R13 is to prevent undesirable interaction among the amplifier tubes.

The plate circuits of these amplifier tubes are connected to the primary transformer T1 which is an iron-cored transformer operating at carrier frequencies. The secondary of this transformer is designed to supply a resistance load of any value between 50 and 500 ohms. By making the inductive reactance of the reactor and variometer in the line coupling tuner equal to the capacitive reactance of the line coupling capacitor, series resonance is obtained and the load on transformer T1 is a pure resistance.

The secondary of transformer T1 also serves as an auto transformer for the received signals and supplies energy to the primary tuned circuit of the receiver formed by capacitor C8 and inductance L4. This circuit, when properly adjusted, is series resonant. The action of the neon glow protector lamp V9 is primarily to destroy this series resonance when local signals are received so that the voltage across inductance L4 never exceeds approximately 150 volts. The current through the neon glow lamp is limited by the relatively high reactance of capacitor C8.

The receiver secondary circuit consisting of capacitor C9 and inductance L5 delivers the carrier frequency voltage directly to the control grid of vacuum tube V2. This tube V2 normally (stand-by conditions) has a sufficient bias voltage applied between its cathode and its grid so that no plate current flows. A received signal overcomes this bias and causes plate current to flow through the receiver relay. The carrier frequency component in the plate circuit of this tube is by-passed by capacitor C11 and the direct current component passes through milliammeter M2 and the receiver relay to the positive bus.

The potentiometer resistor R1 is used to adjust the oscillator and receiver tube voltages to the proper values. Cathode resistors R6 and R7 automatically provide the proper bias for the amplifier tubes. Milliammeter M1 is used to check the current output of the amplifier tubes. The cathode heater current is read by

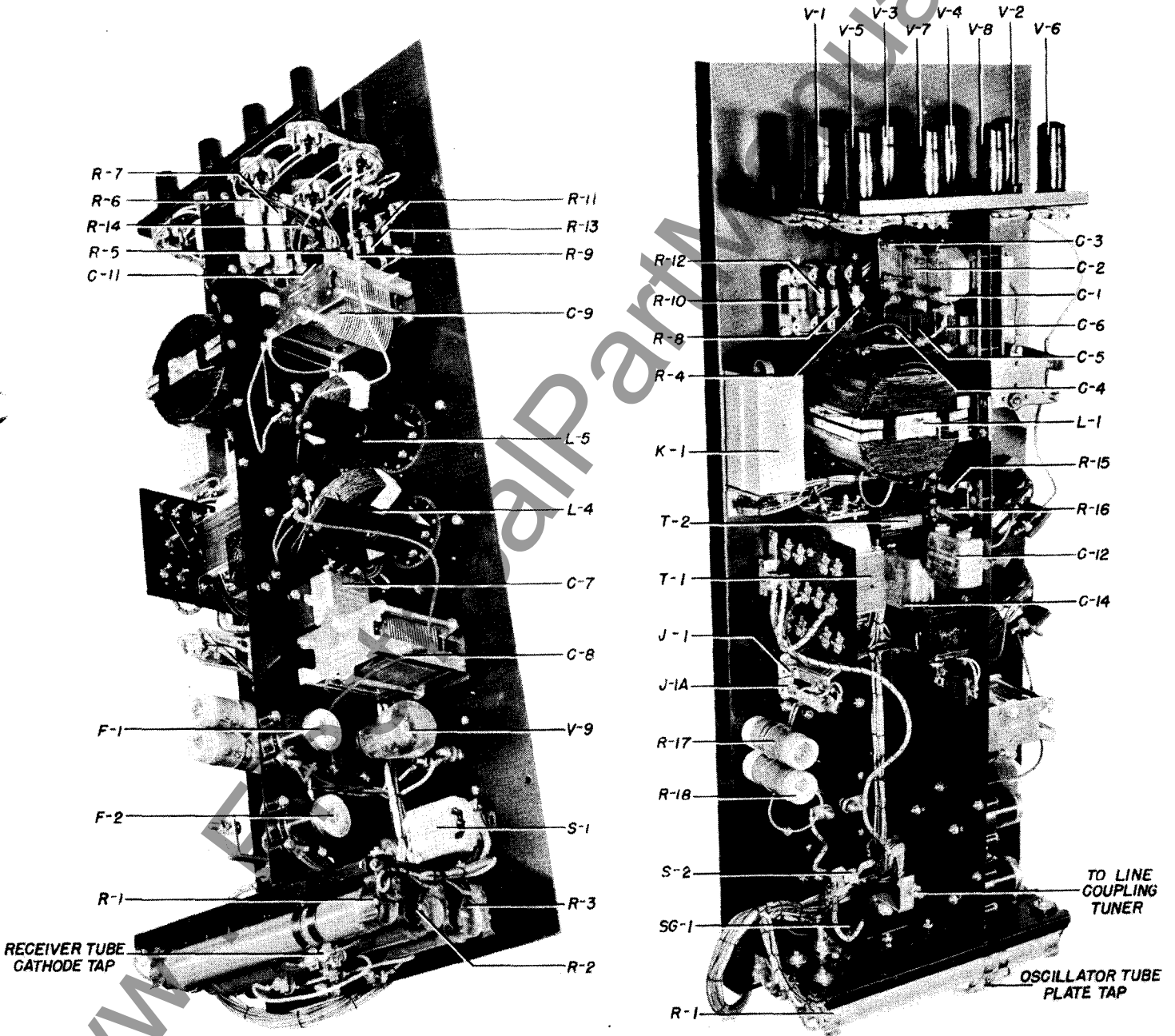

Figure 2
Rear Views of Transmitter-Receiver (Cabinet Removed)

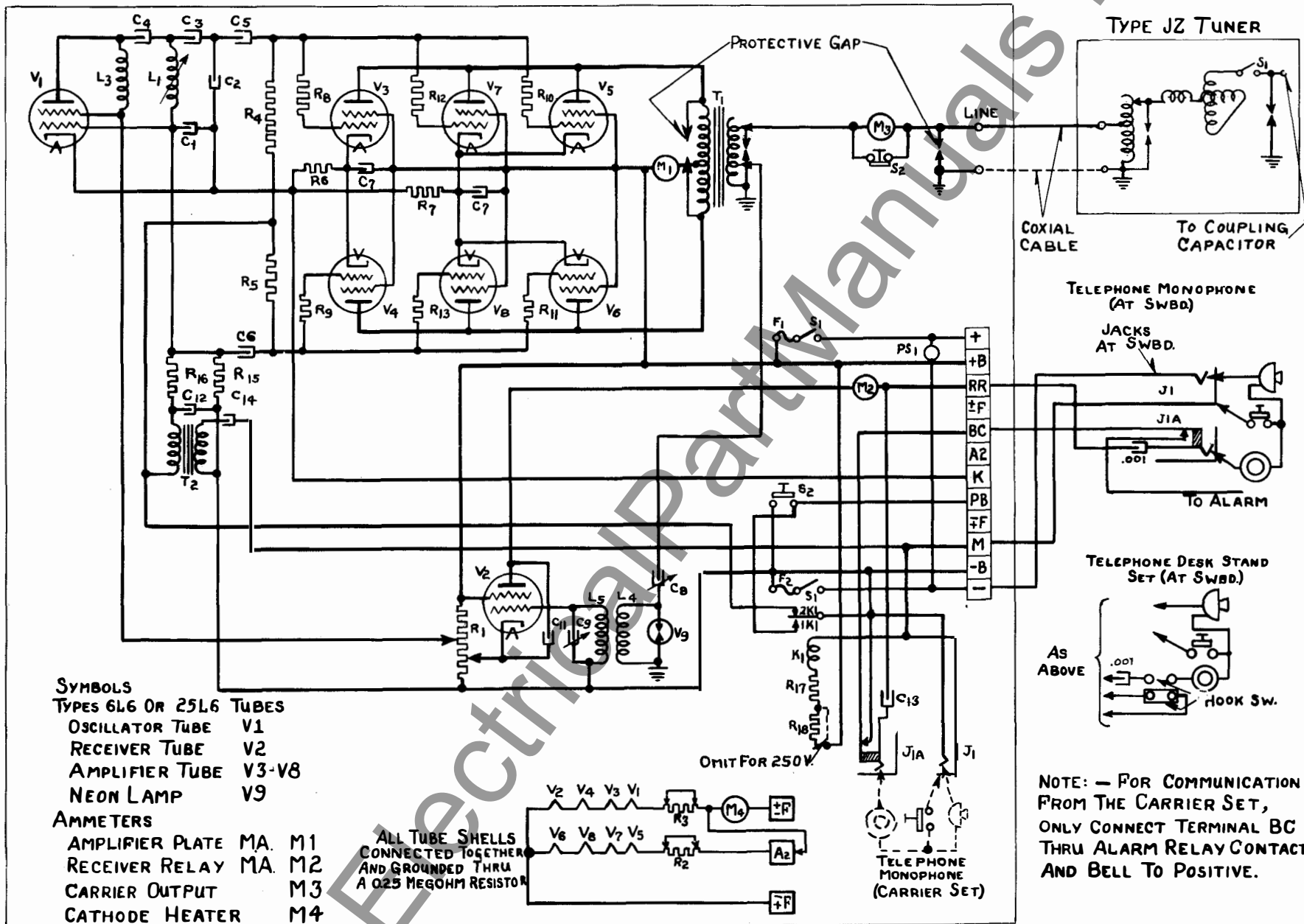
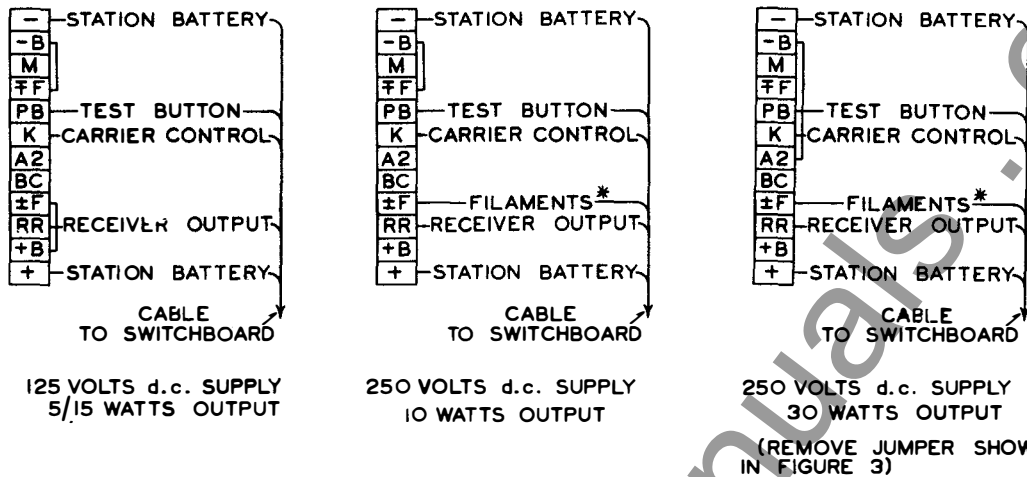

Figure 3

Schematic Internal Wiring of the Transmitter-Receiver (Connections beyond set external connections required for communication).

TYPE 60 CARRIER CURRENT TRANSMITTER-RECEIVER



FOR VOICE COMMUNICATION MAKE THE ADDITIONAL EXTERNAL CONNECTIONS SHOWN IN FIGURE 3.

* CONNECT TO 220 OHM RESISTOR AT SWITCHBOARD THEN TO POSITIVE OF STATION BATTERY.

Figure 4
External D-C. Connections to the Relay Equipment

the ammeter M4, and is adjusted by resistors R2 and R3. These circuits are arranged so that either two or six amplifier (total of either 4 or 8) tubes may be used as required for a specific application. The power output with six amplifier tubes will be approximately three times the value which can be obtained with only two tubes.

Protective gaps as indicated on the diagram are provided to prevent possible damage from lighting or switching surges.

Switch S1 and fuses F1 and F2 completely isolate the equipment from the power supply voltage except that the convenience outlet PS-1 is still energized. Test button S2 is arranged so that it normally shunts carrier output milliammeter M3, but this shunt is removed when the button is pressed to check the transmitter.

Point to Point Voice Communication

Point-to-point voice communication is possible from the carrier set by plugging a telephone hand-set in jacks J1 and J1A. If desired a duplicate set of jacks may be located on the switchboard, or a desk-type telephone set located on the station operator's desk for communication from any of these points, as well as from the carrier set. It should be noted that communication can be carried on from only one location at a time. The connections are shown schematically in figure 3.

The modulating components of the carrier set are the microphone transformer T2; the relay K1; the grid-bias resistor and condenser

R16 and C12; telephone jacks J1 and J1A; relay resistors R17, R18; and condensers C13, C14. In the 100 to 150 volt carrier sets the resistor R18 should be shorted out as shown in figure 3. When communication is desired, the operator plugs his hand-set in jacks J1 and J1A and signals the distant operator by pressing the push button on the telephone set. This starts carrier by energizing relay K1 which closes its contacts 1K1. Contact 1K1 connects negative to the oscillator tube cathode circuit thru terminal K. Starting carrier rings the carrier alarm bell at the distant station. Plugging in the telephone hand-set will disconnect the local alarm bell to prevent it from ringing during communication or when signalling the distant station. This is done by the test jack J1A opening the bell circuit terminals BC to -B. At the completion of the predetermined communication signal the local operator releases his push button on his hand-set. The distant operator plugs in his hand-set and talks to the first operator after closing the push button on the hand-set.

While the initiating operator is talking, the distant operator should listen but not close his hand-set push button. If both operators close the hand-set push button at the same time, communication is difficult because of a heterodyne signal being set up. The speaking operator only should push the hand-set button while talking and when he desires to listen, he should release his push button. Then, the other operator should close his push button and talk.

Closing the hand-set push button also energizes the telephone microphone directly from the station battery thru the relay K1, R17 and R18. The relay contact 2K1 modifies the bias connections of the amplifier tubes by discon-

necting the bias resistors R4 and R5 from -B and connecting them thru the secondary of the microphone transformer T2 to the modulator grid bias resistor R16 and condenser C12. This transfer increases the oscillator tube grid leak to approximately twice its normal value and reduces the oscillator output very slightly in order to produce the necessary bias to the amplifier tube grids. Modulation by the grid bias variation method is then possible. Talking into the microphone sets up voice frequency currents which circulate thru the microphone, condenser C14 and transformer T2 primary circuit. These currents are transformed thru the microphone transformer T2 to modulate the carrier frequency output.

The received signal is demodulated by the receiver tube, V2, and passes thru the handset ear phones from the receiver tube plate thru milliammeter M2 and condenser C13 to -B.

INSTALLATION AND ADJUSTMENT

Installation

The type GO transmitter-receiver equipment as supplied includes an accessory package in addition to the main cabinet. The items received should be carefully checked against the parts list which will be found in a later section of this book and also against the order or requisition for the equipment. Any shortage should be reported immediately to the transportation company, and the nearest district office of the manufacturer. The equipment should be very carefully checked for damaged or missing parts and particular attention should be given to any parts which have become loose in shipment or wires which have broken due to vibration.

The indoor transmitter-receiver set should be mounted in a convenient location which is protected from the weather. It is recommended that the set be mounted in an accessible location and as near to the switchboard as possible in order to reduce the length of leads through the associated relays or other equipment. The cabinet outline is shown in figure 12.

The necessary connections from the transmitter-receiver to the switchboard or power supply are to be made in a suitable conduit installed in the knock-out in the bottom of the transmitter-receiver cabinet. Number 12 gauge wire is recommended for these connections. Before actually making these connections, the detailed installation diagram should be compared with the external connection diagrams of figure 4 to be sure that there is no conflict.

Do not insert any of the tubes or fuses in the transmitter-receiver unit until the following sections dealing with circuit adjustments have been read through very carefully.

Circuit Adjustments

The first consideration when putting this equipment into operation will be the choice of carrier frequency. Prior to shipment, the equipment is very carefully tested and adjusted for operation at 100 kilocycles with a 50 ohm equivalent line resistance, 125 or 250 volt battery, and all eight vacuum tubes.

Tables of adjustment data and curves covering the operation of the equipment under all normal conditions are included as an aid to making adjustments. These tables cover the adjustment of the equipment as shipped from the factory. If conditions in the field differ from the final factory adjustment conditions, it will

be necessary to refer to the curves of figures 5 to 11 and vary the adjustments accordingly. Some of the values in the table should be the same for all installations and, therefore, no curves are given for these quantities. Separate tables are given for 125 volt operation and for 250 volt operation, even though many of the values in both tables are the same. Type 25L6 tubes are to be used for 100 to 150 volt operation and Type 6L6, for 200 to 300 volt operation. During the preliminary adjustments, all eight tubes of the correct type should be used until the equipment is operating satisfactorily. After the adjustments are complete, if it is found that all of the available power is not required, four of the tubes may be removed and certain of the adjustments as indicated below changed accordingly. The connections shown in figure 4 should also be changed if necessary.

The following tabulation gives the type tubes and connections to be used and battery burden for the d-c. supply voltage and radio-frequency outputs shown.

Type No.	Heater Tubes	Normal Heater Conn.	Supply Volts	Battery Load Standby:Amperes	Normal Output Watts	
25L6	4	Series	125	.362	.506	5
25L6	8	2 groups parallel	125	.662	1.026	15
6L6	4	Series	250	.950	1.097	10
6L6	8	Series	250	.950	1.317	30

Add .050 amperes to transmitting loads above when the communication handset-push-button is closed.

The adjustment procedure will follow the tabulation as closely as possible and, therefore, it is important to become thoroughly familiar with the tables. Five columns are included in these tables: the first column indicates the control, instrument or quantity to be checked; the second column indicates the maximum value which is permissible; the third column indicates the minimum value which is permissible; the fourth column indicates the normal value of the quantity; and the fifth column should be filled in at the time of installation to indicate the actual value which was obtained. This last column is of great importance and should always be filled in just as soon as the equipment is installed. A copy of these values should be kept with the equipment for checking purposes and all letters of inquiry to the manufacturer regarding the operation of this equipment should be accompanied by a copy of this form, with all blanks properly filled.

1. The first line in the adjustment data table is the power supply or battery voltage which is to be measured at the terminals of the equipment by connecting a voltmeter into the convenience outlet PS1, which is marked VOLTAGE. The actual value of this voltage should be entered on the line in the fifth column of the data table. The limits given on these quantities are intended to include the maximum variation in power supply voltage, as indicated. It should be observed that the maximum and minimum variations of the values in the table are not all the same percentage. This means that with the actual normal voltage at PS1, the various circuit components can be adjusted within all the limits given, but once the normal voltage is established, it should not be permitted to fluctuate more than + 5%.

2. If the supply voltage is within the limits shown, the fuses and resistors should be

TYPE GO CARRIER CURRENT TRANSMITTER-RECEIVER

inserted in the equipment but no tube should be placed in any socket until the following tests have been made. In order that these fuses and resistors may function properly, they should be carefully checked against the parts list to see that they are of the correct values as marked. The location of these components is shown in figure 2. The two fuses F1 and F2 are to be mounted in the receptacles FS1 and FS2 which are one above the other. The neon lamp V9 is to be inserted later in the third receptacle VS9. Of the three larger resistors, the highest value resistor R1 (2000 ohms for 100 to 150 volt sets, 5000 ohms for 200 to 300 volt sets) is to be inserted in the clips farthest from the front of the panel. These clips are located on the under side of the bottom shelf on the vertical panel. The other two of the larger size resistors R2 and R3 have the same resistance value (160 ohms for 100 to 150 volt sets, 80 ohms for 200 to 300 volt sets) and are to be inserted in the middle and front positions, respectively. The two small resistors R6 (60 ohms for 100 to 150 volt sets, 120 ohms for 200 to 300 volt sets) and R7 (30 ohms for 100 to 150 volt sets, 60 ohms for 200 to 300 volt sets) are to be inserted in the clips on right-hand side (rear-view) of the shield panel. These clips are directly beneath the upper shelf. The lower resistance value resistor R7 is to be inserted in the clips nearest the front of the panel.

3. The power switch S1 should be closed and, if necessary, the taps on resistor R1 should be adjusted so that the oscillator screen and plate voltage, and the receiver cathode voltage, when measured between terminal -B and the proper taps on this resistor, are approximately as indicated by the next two lines of the adjustment data tables. Battery positive + B is connected to the end of the resistor R1 nearest the hinged edge of the vertical panel. The oscillator screen and plate voltage tap is nearest the +B end of R1. These voltages will be adjusted more accurately after some of the other adjustments have been made, but it is important that the values shown be approximately correct so that the vacuum tubes will not be injured.

4. Next, power switch S1 is to be opened, the neon glow lamp V9 and four tubes are to be inserted in the sockets V1 to V4. These are the four sockets on the upper shield nearest the front of the vertical panel. Power switch S1 is then to be closed again and resistor R3 adjusted to obtain the proper cathode heater current M4 which is to be as indicated in the table. Note that when power switch S1 is first closed, the current will be above normal due to the low resistance of the cold cathodes. Consequently, power should be applied for about 30 seconds before the final current check is made. The external connections for various conditions are shown on figure 4.

5. These same diagrams will apply for the next test which is made by transferring the four tubes already in the front sockets to the rear sockets V5 to V8 inclusive. With the tubes in the rear sockets, the resistor in the middle position R2 is to be adjusted to give the correct value of cathode heater current ammeter M4 as indicated in the table.

6. Next, all eight of the tubes, V1 to V8 inclusive are to be inserted in their sockets and the connections changed per figure 4, if necessary. With this setup, the cathode heater current ammeter M4 is to be checked against the tables.

7. During the above adjustments, the test button S2 should not be pressed, and all cur-

rents other than the cathode heater current should be zero, with the possible exception of the receiver relay current milliammeter M2. If any of the other instruments indicate current, the cause should be determined before proceeding with the test.

8. The receiver cathode tap on resistor R1 should be adjusted and the voltage should be as indicated by the data tables. The data tables indicate the standby receiver relay current, which is a very small value. The limits shown are intended to indicate that this current should be the lowest possible value which will move the pointer on the milliammeter.

9. The next adjustment determines the frequency of the equipment. The adjustment data given in the tables are for a frequency within the limits as indicated. If the frequency to be used is other than 100 kilocycles, the oscillator frequency dial, L1, which controls the carrier frequency transmitted should be changed according to the curve of figure 5. When practical, this frequency should be checked by a wavemeter and the actual value entered in the table.

10. The next adjustment is the receiver primary inductance L4. Either the whole coil should be used or the larger portion of it from the tap to the finish end of the coil. The two curves of figure 6 indicate the effect of this adjustment and show quite clearly that it is of little importance except near the ends of the frequency range. The receiver secondary inductance L5 is identical with L4 and should be adjusted in the same manner. The axes of these coils may be turned so as to form any desired angle with a corresponding value of coupling between them. This coupling is not important as long as the axes of the coil are not coincidental, nor at right angles to each other. Maximum coupling occurs when the axes are coincidental and approaching this adjustment will increase the receiver sensitivity.

11. On the average open-wire transmission line the carrier signal received from the transmitter at the other end of the line is so strong that the location of the receiver tap on transformer T1 is not very critical. The usual location of the receiver tap is between taps 5 and 9. It is only on a weak received signal and for very selective tuning that it is necessary for careful matching of the receiver circuit thru the selection of the receiver tap. Very selective tuning is necessary only where adjacent line sections have carrier frequencies less than 10 kilocycles apart. Where less than 10 kilocycle separations between adjacent lines are required, the manufacturer should be consulted.

12. In order to get maximum carrier frequency transmitter efficiency, it is important to carefully match the impedance of transformer T1 to the impedance of the transmission line, as measured from the line coupling tap. When the line coupling tuner is properly tuned for series resonance these impedances appear as effective resistance. The curves of figure 7 show the relation between this equivalent line resistance and the line coupling taps on transformer T1. For average open-wire transmission lines the equivalent line resistance is about 500 ohms. However, coaxial cable of the type commonly used between the transmitter-receiver and the line coupling tuner has a characteristic impedance of about 50 ohms.

13. The next adjustment is quite important. Figures 8, 9, 10 and 11 show the effect of os-

TYPE GO CARRIER CURRENT TRANSMITTER-RECEIVER

oscillator plate voltage upon the plate currents and output currents. These curves have also been plotted to indicate the product obtained by multiplying the readings of amplifier plate current milliammeter M1 and carrier output milliammeter M3. The object of this adjustment is to obtain a value of oscillator voltage which will result in the maximum of this product. By referring to the curves, it will be seen that as the oscillator plate voltage is increased above a certain value, the amplifier plate current decreases rather rapidly. It will also be noted that the carrier output current does not increase much after a certain oscillator plate voltage is reached. The product of these two currents reaches a maximum under the best operating conditions. Therefore, the oscillator plate voltage tap on resistor R1 is to be moved slightly from its initial adjustment and the readings of the milliammeters M1 and M3 observed and multiplied together as a check for the maximum value of the product. Regardless of installation conditions, the amplifier plate current as read on milliammeter M1 should be within the limits indicated in the data tables, but the carrier output current, as indicated on milliammeter M3, may vary quite considerably from the values given if the equivalent line resistance is other than 50 ohms. This variation in output current will cause the product to vary correspondingly.

CAUTION: Do not attempt this adjustment until the line coupling tuner has been adjusted for resonance.

14. If suitable instruments are available, the oscillator combined plate and screen current should be measured by disconnecting the tap nearest the +B end of R1 and connecting a milliammeter in series with this lead. This test is not particularly important, but it serves as a convenient means of checking the equipment at a later date if trouble develops. However, it is of considerable importance that the oscillator plate and screen voltage be recorded, since this must be within the limits shown in order to insure satisfactory tube life.

15. After the above adjustments are completed, carrier should be transmitted from the remote equipment so that the receiver may be adjusted for maximum receiver relay current indicated by milliammeter M2. The approximate settings for the receiver primary capacitor C8 and the receiver secondary capacitor C9 are indicated by figure 6. It is usually necessary to adjust these capacitors slightly to obtain resonance with the remote signal. It will generally be found impossible to adjust these controls by receiving from the local transmitter, since the signal strength is so great that the receiver will tune very broadly. As a matter of fact the values shown by the curve are much more accurate than the settings which may be obtained using the local transmitter. When the remote signal has been tuned in, the receiver relay current milliammeter M2 should be recorded and then the test button S2 pressed, and this current again recorded for the local transmission condition. This completes the adjustment of the equipment for normal conditions and all of the blanks in the fifth column of the adjustment data table should be filled in before leaving the equipment. It is desirable to repeat the above adjustments two or three times in order to be sure that the best settings have been obtained.

On rare occasions the noise level on the transmission lines due to line-switching disturbances or interference from other carrier sets may be great enough to increase the receiver plate current above the pick-up value of the receiver relay element. This interference may

be reduced in either of two ways, or by a combination of both.

1. By reducing the coupling between L4 and L5 to near its minimum value. (Minimum coupling occurs when the coil axes are at right angles.)

2. By increasing the receiver tube cathode voltage. The cathode voltage is increased by moving the receiver tap on resistor R1 toward the +B end of the resistor. This reduction of interference is a matter of trial and error. As both the desired signal and interference signal are reduced by these adjustments, care should be taken that the desired signal is not reduced below a safe operating value of the receiver relay element.

OPERATION

When this equipment is properly installed and adjusted, it may be placed in operation by closing the safety disconnect switch in the line coupling tuner and power switch S1. The transmission of carrier is automatically controlled by the associated relays and requires no attention on the part of the operator except maintenance, as explained in a separate section. The equipment may be taken out of service at any time by opening the power and disconnect switches, in which case, there is no power consumed from the supply source and no appreciable deterioration of the equipment over long period of time.

In connection with the installation and maintenance of this equipment, several instruments which are not ordinarily used for 60 cycle measurements, such as a cathode ray oscilloscope, several thermocouple voltmeters and ammeters, a multi-scale high resistance d-c. voltmeter having at least 1000 ohms per volt, a multi-scale d-c. milliammeter, a suitable tube checker, and a wavemeter for carrier frequency will be found very helpful.

MAINTENANCE

After installation, the equipment should be inspected daily for the first week or two to see that it functions properly and that nothing overheats. This procedure will permit the operators to become familiar with the equipment. After the first two weeks, a careful inspection once every week will be sufficient. When these weekly inspections are made, all meter readings should be recorded.

Vacuum Tubes

If any discrepancy of the meter readings is noticed after a considerable period of operation, all of the vacuum tubes should be checked to see that they are still in good condition. Occasionally, a defective tube will appear within the first month of operation. In general, no tube trouble should be experienced after this period until the useful life of the vacuum tube has expired. Owing to the wide variation in the activity of the equipment, it is impossible to state how long the vacuum tubes may be expected to operate. If a standard type of tube checker is used for testing the vacuum tubes, the limits which are given in the instruction book covering its use will usually be found satisfactory. If no tube checker is available, it will be found satisfactory to check each of the questionable tubes in the oscillator socket VS1 which is in the front right-hand corner of the tube shelf. In making this test, tubes which are known to be satisfactory should be inserted in all of the other sockets and the carrier frequency current into the line coupling capacitor should be observed for the

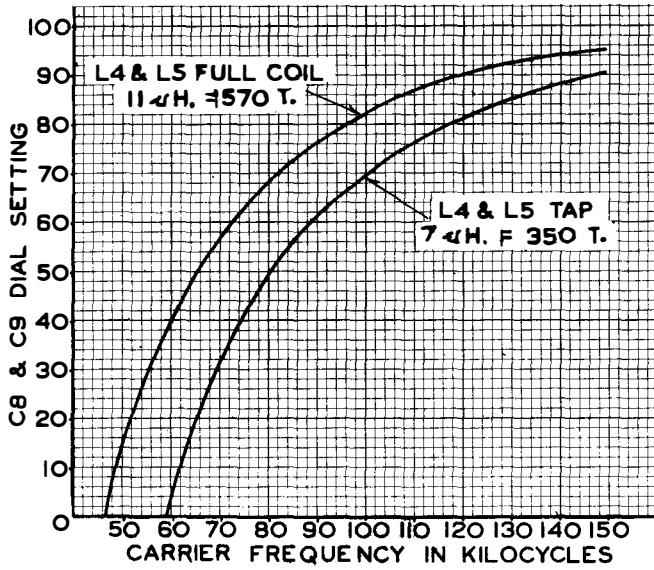

Figure 5
Frequency Calibration Curve of the Oscillator

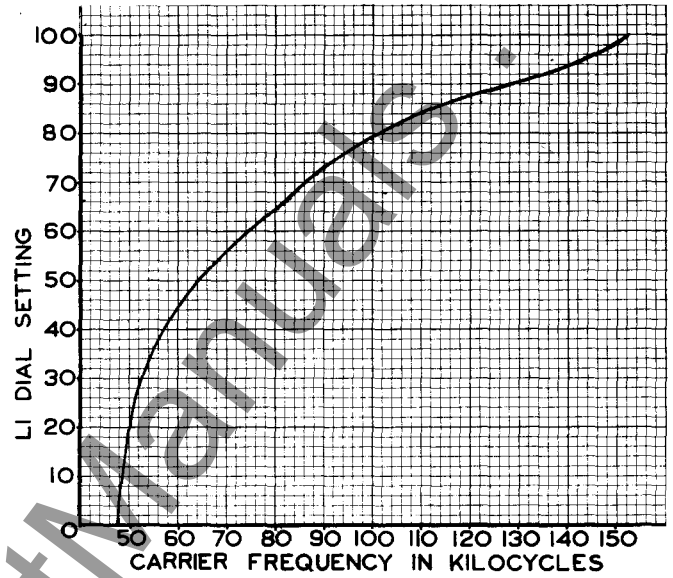

Figure 6
Frequency Calibration Curve of the Receiver

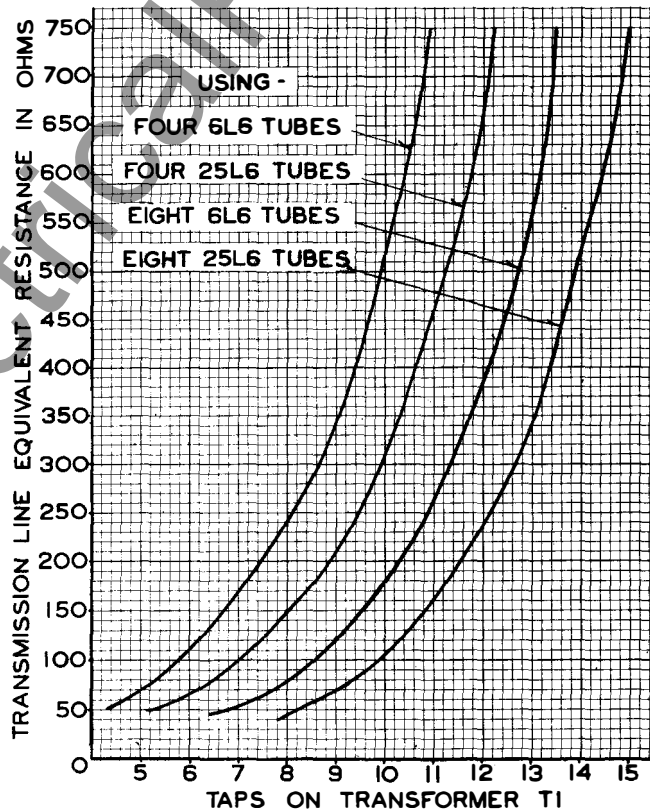

Figure 7
Curve for Matching Transformer T1 to the Equivalent Resistance of the Transmission Line from the Transmitter-Receiver to the Line Coupling Tuner.

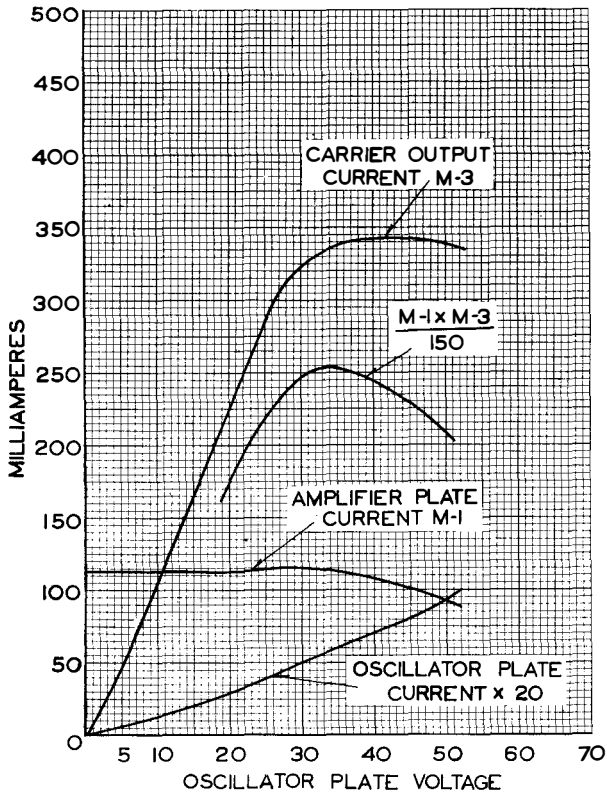

Figure 8
Oscillator Output Characteristics Using Four Type 25L6 Tubes (50 ohm load).

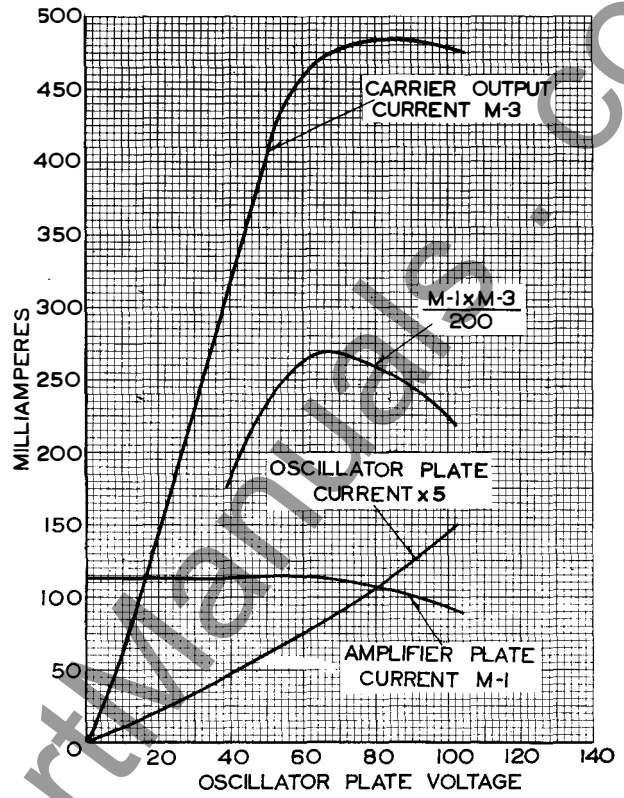

Figure 9
Oscillator Output Characteristics Using Four Type 6L6 Tubes (50 ohm load).

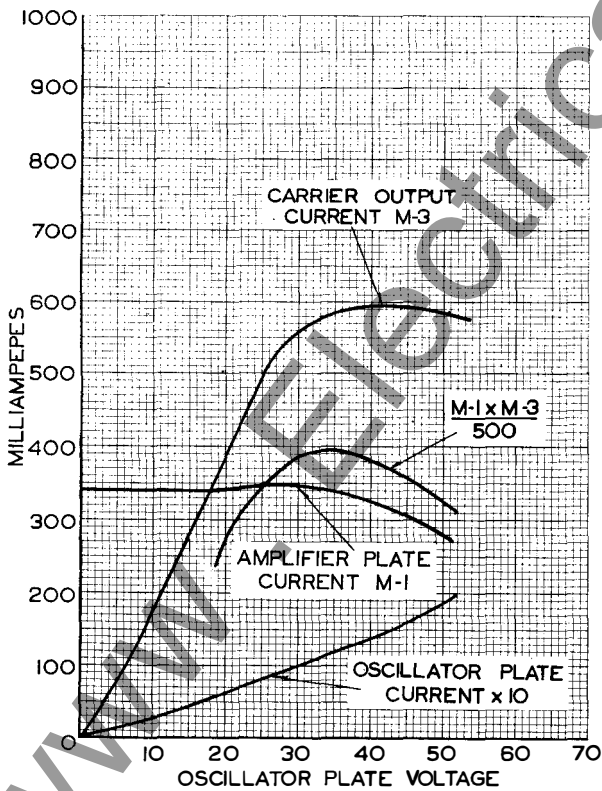

Figure 10
Oscillator Output Characteristics Using Eight Type 25L6 Tubes (50 ohm load).

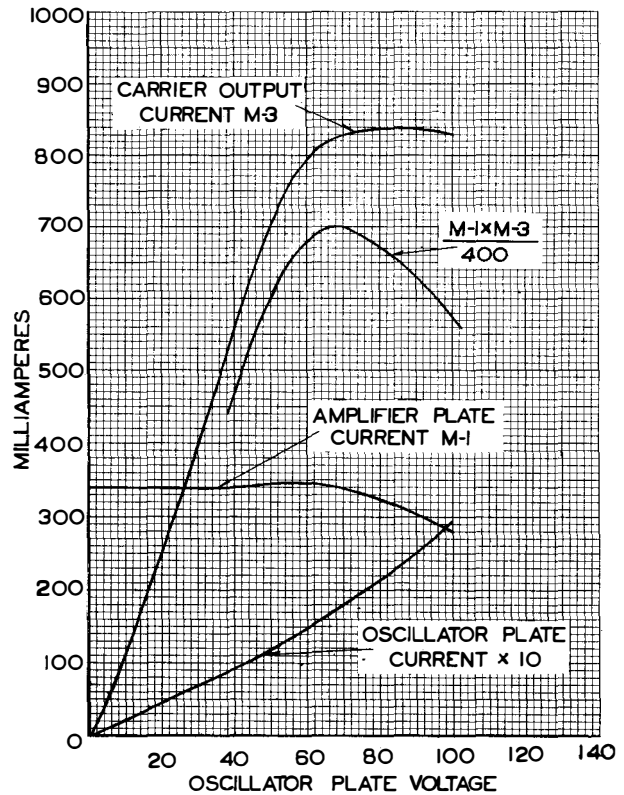

Figure 11
Oscillator Output Characteristics Using Eight Type 6L6 Tubes (50 ohm load).

TYPE G0 CARRIER CURRENT TRANSMITTER-RECEIVER

normal oscillator plate voltage which is used. A tube which does not oscillate after applying normal heater current for one minute will be considered unsatisfactory. Also, a tube which, used as an oscillator does not permit the equipment to deliver approximately full power output should be replaced. No definite end limits can be given because of the wide variations in transmission efficiencies of various lines. On short or low loss lines, tubes can be used which would be too weak for use on long or high loss lines.

At the end of each year of operation, the vacuum tubes should be removed from their sockets and their contacts inspected for possible dirt or corrosion. If there is any discoloration, it may be removed by the use of very fine sandpaper. In order to insure maximum tube life, it is very important that the resistance of these contacts be kept to an absolute minimum. If necessary, this cleaning operation should be performed more frequently than indicated above.

Fuses

Since the fuses in this equipment are primarily intended to protect only against short circuits or very severe overloads, they will probably never fail during the life of the equipment. It is desirable that they be removed at the end of each year of operation and that any corrosion which may have occurred, be removed by the use of fine sandpaper.

Resistors

As in the case of other components, the resistors are operated well within their rating and should not fail during the life of the equipment. It is desirable that they be removed from their clips at the end of each year of operation, and that any corrosion which may have occurred be removed by the use of fine sandpaper.

Instruments

At the end of each year's operation, the zero adjustments of all instruments should be checked. If facilities are available for checking the cathode heater ammeter M4 against a suitable standard, this should be done at the end of each year's operation. This calibration must be made with the meter mounted on a 3/32 inch steel panel as in the transmitter-receiver assembly. The accuracy of the other instruments is not considered of sufficient importance to warrant such calibration unless it is known that they have been seriously overloaded, or their indication is believed, for some other reason, to be incorrect.

PARTS LISTS

Shipping Lists for Type G0 Transmitter-Receiver

Style 867499 covers equipment for 100 to 150 volts D.C. supply. It is identified as DL-7501950 G-48 and includes:

1 Transmitter-Receiver DL-7501950 G-47

1 Accessories Package DL-7501950 G-50 which includes :

- 16 - R.C.A. Radiotrons type 25-L-6, Symbol V-1 to V-8
- 2 - Neon Glow Lamps 2 Watts 115 Volts S-14 Clear Med. Screw Base, Symbol V-9
- 4 - Fuses 6 Amp. 125 V. Bryant Type POR-6, Symbol F-1 & F-2

- 1 - Resistor 2000 Ohms, 200 Watts, Symbol R-1
- 2 - Resistors 160 Ohms, 200 Watts, Symbols R-2, R-3
- 1 - Resistor 60 Ohms, 12 Watts, Symbol R-6
- 1 - Resistor 30 Ohms, 12 Watts, Symbol R-7
- 1 - Name Plate #19914

Style 867500 covers equipment for 200-300 volt D.C. supply. It is identified as DL-7501950 G-49 and includes:

1 Transmitter-Receiver DL-7501950 G-47

1 Accessories Package DL-7501950 G-51 which includes:

- 8 - RCA Radiotrons, Type 6-L-6, Symbols V-1 to V-4
- 2 - Neon Glow Lamps, 2 W. 115 V. S-14 Clear Med. Screw base, Symbol V-9
- 4 - Fuses 6 Amp. 250 V. Bryant #7054 & Casing #1915, Symbols F-1 & F-2
- 1 - Resistor 5000 Ohms, 200 W. Symbol R-1
- 2 - Resistors, 80 Ohms, 200 W. Symbols R-2, R-3
- 1 - Resistor, 130 Ohms, 12 W. Symbol R-6
- 1 - Resistor, 60 Ohms, 12 W. Symbol R-7
- 1 - Name Plate #19914
- 1 - Resistor Assembly, 4 of 880 ohms W-L 8-1/2 inch D Type 204 Terminals, type 721 mounting in parallel for 220 Ohms total.

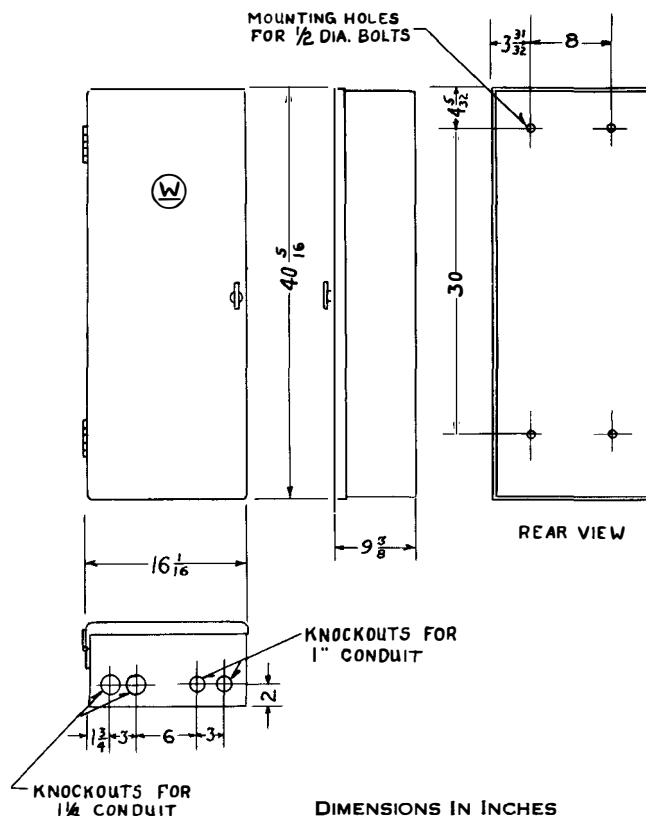

Figure 12
Outline and Drilling Plan for the Transmitter-Receiver Cabinet.

TYPE GO CARRIER CURRENT TRANSMITTER-RECEIVER

ADJUSTMENT DATA FOR 100-150 VOLT EQUIPMENT (FOUR OR EIGHT TYPE 25L6 TUBES)
 See Text of instruction book for detailed discussion of following table.
 Numbers preceding data refers to text paragraph numbers.

	Max.	Min.	Norm.	Actual
1. With Power Switch S-1 off				
Volts Battery (Power Supply) Voltage Outlet PS-1.....	150	100	125	_____
2. With Fuses and Resistors but no Tubes in any Socket				
3. Switch S-1 on				
Volts Oscillator Screen & Plate -B to tap on R-1 (approximate adjustment)..	44	26	35	_____
Volts Receiver Tube Cathode -B to tap on R-1 (approximate adjustment)..	25	15	20	_____
4. With Neon Glow Lamp V-9 and Four Front Tubes V-1 to V-4 in Sockets				
Adjust R-3 for Amperes Cathode Heater Current M-4.....	.296	.268	.282	_____
5. With Front Tubes Out and Four Rear Tubes V-5 to V-8 in Sockets				
Adjust R-2 for Amperes Cathode Heater Current M-4 (For Four Tube Operation).	.296	.268	.282	_____
6. With all Eight Tubes V-1 to V-8 in Sockets - Adjust R-2 for Amperes Cathode Heater Current M-4 (For Eight Tube Operation).....	.592	.535	.564	_____
7. With Test Button S-2 Open, M-1 and M-3 Must Be Zero				
8. Adjust Receiver Cathode Tap on R-1 for Milliamps. Receiver Relay M-2.	.10	.01	.05	_____
Volts Receiver Tube Cathode -B to tap on R-1 (final adjustment).....	25	15	20	_____
9. Adjust to Desired Frequency Referring to Curves - Data below are for				
*9. Frequency in Kilocycles.....	101	99	100	_____
9. Oscillator Frequency Dial L-1.....	85	75	80	_____
# Equivalent Line Resistance in Ohms.....	55	45	50	_____
*10. Receiver Primary Winding L-4.....	Total	Tap	Total	_____
*10. Receiver Secondary Winding L-5.....	Total	Tap	Total	_____
10. Receiver Primary Axis L-4.....	100	75	88	_____
10. Receiver Secondary Axis L-5.....	100	75	88	_____
#11. Receiver Primary C-8 Tap on T-1 (For Four Tube Operation).....	7	6	6	_____
#11. Receiver Primary C-8 Tap on T-1 (For Eight Tube Operation).....	9	8	8	_____
#12. Output Tap on T-1 (For Four Tube Operation).....	7	5	6	_____
#12. Output Tap on T-1 (For Eight Tube Operation).....	10	8	9	_____
13. Adjust Oscillator Plate Voltage Tap on R-1 for Maximum Product of				
Amplifier Plate Current times Carrier Output Current M-1 x M-3.....				
Milliamps. Amplifier Plate Current M-1 (For Four Tube Operation).....	133	87	113	_____
Milliamps. Amplifier Plate Current M-1 (For Eight Tube Operation).....	400	260	340	_____
#Milliamps. Carrier Output Current M-3 (For Four Tube Operation).....	390	300	340	_____
#Milliamps. Carrier Output Current M-3 (For Eight Tube Operation).....	670	510	585	_____
#Product M-1 x M-3 ÷ 150 (For Four Tube Operation).....	375	165	250	_____
#Product M-1 x M-3 ÷ 500 (For Eight Tube Operation).....	600	270	400	_____
14. Disconnect Tap on R-1 nearest hinged edge of Panel and insert				
Milliammeter				
*Milliamps. Oscillator Plate and Screen.....	21	8.5	14	_____
*Volts Oscillator Plate & Screen -B to Tap on R-1 (final adjustment).....	55	20	35	_____
15. With Carrier from Remote Transmitter, Adjust Receiver for Maximum				
Receiver Relay Current M-2.				
*Receiver Primary Capacitor Dial C-8.....	87	77	82	_____
*Receiver Secondary Capacitor Dial C-9.....	87	77	82	_____
Milliamps. Receiver Relay current M-2 (Remote Transmitter Test).....	30	10	15	_____
15. With Test Button S-2 Closed.				
Milliamps. Receiver Relay Current M-2 (Local Transmitter Test).....	35	10	22	_____
Repeating 13 to 15 readings above with Handset HS-1 in Jacks J1 and J1A and				
Handset Button Pressed closed.				
Milliamps. Amplifier Current M-1 (For Four Tube Operation).....	106	70	88	_____
Milliamps. Amplifier Current M-1 (For Eight Tube Operation).....	310	210	260	_____
#Milliamps. Carrier Output Current M-3 (For Four Tube Operation).....	310	235	270	_____
#Milliamps. Carrier Output Current M-3 (For Eight Tube Operation).....	525	400	460	_____
#Product M-1 x M-3 ÷ 150 (For Four Tube Operation).....	250	110	167	_____
#Product M-1 x M-3 ÷ 500 (For Eight Tube Operation).....	400	180	267	_____
Milliamps. Receiver Relay Current M-2 (Local Transmitter Test).....	28	10	18	_____
Volts Extra Modulator Bias across C-12.....	14	10	12	_____
Milliamps. Total Load on Battery, Standby (For Four Tube Operation).....			362	_____
Milliamps. Total Load on Battery, Standby (For Eight Tube Operation).....			662	_____
Milliamps. Total Load on Battery, Transmitting (For Four Tube Operation)...			506	_____
Milliamps. Total Load on Battery, Transmitting (For Eight Tube Operation)..			1026	_____
Add 50 Milliampere to Transmitting loads above when the communication hand set push-button is closed.				

* These values vary with frequency. See Curves.
 # These values vary with equivalent line resistance. See Curves.

TYPE GO CARRIER CURRENT TRANSMITTER-RECEIVER

ADJUSTMENT DATA FOR 200-300 VOLT EQUIPMENT (FOUR OR EIGHT TYPE 6L6 TUBES)
See Text of instruction book for detailed discussion of following table.
Numbers preceding data refer to text paragraph numbers.

	Max.	Min.	Norm.	Actual
1. With Power Switch S-1 off				
Volts Battery (Power Supply) Voltage Outlet PS-1.....	300	200	250	_____
2. With Fuses and Resistors but no Tubes in any Socket.....				
3. Switch S-1 on				
Volts Oscillator Screen & Plate -B to tap on R-1 (approximate adjustment)...	88	52	70	_____
Volts Receiver Tube Cathode -B to tap on R-1 (approximate adjustment)...	50	30	40	_____
4. With Neon Glow Lamp V-9 and Four Front Tubes V-1 to V-4 in Sockets				
Adjust R-3 for Amperes Cathode Heater Current M-4.....	.888	.804	.845	_____
5. With Front Tubes Out and Four rear Tubes V-5 to V-8 in Sockets				
Adjust R-2 for Amperes Cathode Heater Current M-4 (For Four Tube Operation)...	.888	.804	.846	_____
6. With all Eight Tubes V-1 to V-8 in Sockets - Adjust R-2 for Amperes				
Cathode Heater Current M-4 (For Eight Tube Operation).....	.888	.804	.846	_____
7. With Test Button S-2 Open, M-1 and M-3 Must Be Zero				
8. Adjust Receiver Cathode Tap on R-1 for Milliamps. Receiver Relay M-2	.10	.01	.05	_____
Volts Receiver Tube Cathode -B to tap on R-1 (final adjustment).....	50	30	40	_____
9. Adjust to Desired Frequency Referring To Curves - Data below are for				
*9. Frequency in Kilocycles.....	101	99	100	_____
9. Oscillator Frequency Dial L-1.....	85	75	80	_____
# Equivalent Line Resistance in Ohms.....	55	45	50	_____
*10. Receiver Primary Winding L-4.....	Total	Tap	Total	_____
*10. Receiver Secondary Winding L-5.....	Total	Tap	Total	_____
10. Receiver Primary Axis L-4.....	100	75	88	_____
10. Receiver Secondary Axis L-5.....	100	75	88	_____
#11. Receiver Primary C-8 Tap on T-1 (For Four Tube Operation).....	6	5	5	_____
#11. Receiver Primary C-8 Tap on T-1 (For Eight Tube Operation).....	8	7	7	_____
#12. Output Tap on T-1 (For Four Tube Operation).....	6	5	5	_____
#12. Output Tap on T-1 (For Eight Tube Operation).....	8	6	7	_____
13. Adjust Oscillator Plate Voltage Tap on R-1 for Maximum Product of				
Amplifier Plate Current times Carrier Output Current M-1 x M-3				
Milliamps. Amplifier Plate Current M-1 (For Four Tube Operation).....	133	87	113	_____
Milliamps. Amplifier Plate Current M-1 (For Eight Tube Operation).....	400	260	340	_____
#Milliamps. Carrier Output Current M-3 (For Four Tube Operation).....	550	400	475	_____
#Milliamps. Carrier Output Current M-3 (For Eight Tube Operation).....	950	700	825	_____
#Product M-1 x M-3 ÷ 200 (For Four Tube Operation).....	380	180	270	_____
#Product M-1 x M-3 ÷ 400 (For Eight Tube Operation).....	900	500	700	_____
14. Disconnect Tap on R-1 nearest hinged edge of Panel and insert				
Milliammeter				
*Milliamps. Oscillator Plate and Screen.....	27	10	17	_____
*Volts Oscillator Plate & Screen -B to Tap on R-1 (final adjustment).....	110	40	70	_____
15. With Carrier from Remote Transmitter, Adjust Receiver for Maximum				
Receiver Relay Current M-2.				
*Receiver Primary Capacitor Dial C-8.....	87	77	82	_____
*Receiver Secondary Capacitor Dial C-9.....	87	77	82	_____
Milliamps. Receiver Relay Current M-2 (Remote Transmitter Test).....	30	10	15	_____
15. With Test Button S-2 Closed.				
Milliamps. Receiver Relay Current M-2 (Local Transmitter Test).....	35	10	22	_____
Repeating 13 to 15 readings above with Handset HS-1 in Jacks J1 and J1A and				
Handset Button pressed closed.				
Milliamps. Amplifier Current M-1 (For Four Tube Operation).....	106	70	88	_____
Milliamps. Amplifier Current M-1 (For Eight Tube Operation).....	310	210	260	_____
#Milliamps. Carrier Output Current M-3 (For Four Tube Operation).....	440	320	380	_____
#Milliamps. Carrier Output Current M-3 (For Eight Tube Operation).....	760	560	660	_____
#Product M-1 x M-3 ÷ 200 (For Four Tube Operation).....	250	120	180	_____
#Product M-1 x M-3 ÷ 400 (For Eight Tube Operation).....	600	330	470	_____
Milliamps. Receiver Relay Current M-2 (Local Transmitter Test).....	28	10	18	_____
Volts Extra Modulator Bias across C-12.....	18	14	16	_____
Milliamps. Total Load on Battery, Standby (For Four Tube Operation).....			950	_____
Milliamps. Total Load on Battery, Standby (For Eight Tube Operation).....			950	_____
Milliamps. Total Load on Battery, Transmitting (For Four Tube Operation)....			1097	_____
Milliamps. Total Load on Battery, Transmitting (For Eight Tube Operation)...			1317	_____
Add 50 Milliampere to Transmitting loads above when the communication hand-				
set push-button is closed.				

* These values vary with frequency. See Curves.

These values vary with equivalent line resistance. See Curves.

TYPE GO CARRIER CURRENT TRANSMITTER-RECEIVER

COMPONENT PARTS OF TYPE GO TRANSMITTER-RECEIVERS

<u>Symbols</u>	<u>Name</u>	<u>Rating</u>	<u>Designation</u>	<u>Supplier</u>	
<u>CAPACITORS</u>					
C-1	Oscillator Tank	.02 Mfd. 600 WV	Type 9H-11020	C-D	
C-2	Oscillator Tank	.02 Mfd. 600 WV	Type 9H-11020	C-D	
C-3	Oscillator Tank	.02 Mfd. 600 WV	Type 9H-11020	C-D	
C-4	Oscillator Plate	.025 Mfd. 600 WV	Type 9-11025	C-D	
C-5	Amplifier Grid	.0005 Mfd. 600 WV	Type 9-13050	C-D	
C-6	Amplifier Grid	.0005 Mfd. 600 WV	Type 9-13050	C-D	
C-7	Cathode By-pass	2 x .25 Mfd. 500 W.V	Type HC-1075	C-D	
C-8	Receiver Primary	.001 Mfd.	Type XR-1000 PS Mycalex Ins.	Card	
C-9	Receiver Secondary	.001 Mfd.	Type XR-1000 PS Mycalex Ins.	Card	
C-11	Receiver Plate	.005 Mfd. 600 WV	Type 9-11050	C-D	
C-12	Bias Filter	.5 Mfd. 400 WV	Type HC-3217-1	C-D	
C-13	Rec. Speech Filter	.001 Mfd. 600 WV	Type 4-12010	C-D	
C-14	Microphone By-pass	.5 Mfd. 400 WV	Type HC-3217-1	C-D	
<u>FUSES</u>					
F-1	(For 125V Equip.) Plug	6 A. 125 V.	POR-6	Bryant	
F-2	(For 125V Equip.) Plug	6 A. 125 V.	POR-6	Bryant	
F-1	(For 250V Equip.) Cartridge	6 A. 250 V.	#7054 & Casing #1945	Bryant	
F-2	(For 250V Equip.) Cartridge	6 A. 250 V.	#7054 & Casing #1945	Bryant	
<u>FUSE SOCKETS</u>					
FS-1	Receptacle	Med. Screw	H-715	Bryant	
FS-2	Receptacle	Med. Screw	H-715	Bryant	
<u>INDUCTANCES</u>					
L-1	Oscillator Variometer	.17-1.7 M.H.	Dwg. 7605336G-1	W	
L-3	Plate Reactor	50. M.H.	L-332757	W	
L-4	Receiver Primary	11. M.H.	Dwg. 7406582 G-1	W	
L-5	Receiver Secondary	11. M.H.	Dwg. 7406582 G-1	W	
<u>METERS</u>					
M-1	Amplifier Plate	500 MA	Type UX-35 S#1007168*	W	
M-2	Receiver Relay	50 MA	Type UX-35 S#1007159*	W	
M-3	Carrier Output	1.0 Amp.	Type UT-35 S#1159644*	W	
M-4	Cathode Heater	1.0 Amp.	Type UX-35 S#1007040*	W	
*Calibrated for use on 3/32 inch thick Steel Panel.					
<u>PLUG SOCKET</u>					
PS-1	Convenience Outlet	10 A. 250 V.	#4725	Bryant	
<u>RESISTORS</u>					
R-1	Potentiometer	For 125V Equip. 2000 Ohms	8-1/2" D Bare Side 2-604 Bands Type 307 Ferrules	W.L.	
R-1	Potentiometer	For 250V Equip. 5000 Ohms		W.L.	
R-2	Cathode Heater	For 125V Equip. 160 Ohms		W.L.	
R-2	Cathode Heater	For 250V Equip. 80 Ohms		W.L.	
R-3	Cathode Heater	For 125V Equip. 160 Ohms		W.L.	
R-3	Cathode Heater	For 250V Equip. 80 Ohms		W.L.	
R-4	Amplifier Grid	50,000 Ohms 1 W.		Type GS	Stack.
R-5	Amplifier Grid	50,000 Ohms 1 W.		Type GS	Stack.
R-6	Amplifier Cathode	For 125V Equip. 60 Ohms	1-3/8" T Type 300 Ferrules	W.L.	
R-6	Amplifier Cathode	For 250V Equip. 120 Ohms		W.L.	
R-7	Amplifier Cathode	For 125V Equip. 30 Ohms		W.L.	
R-7	Amplifier Cathode	For 250V Equip. 60 Ohms		W.L.	
R-8 to R-13	Parasitic	1000 Ohms, 1W.	Type GS	Stack	
R-15	Oscillator Grid	10000 Ohms, 1 W.	Type GS	Stack.	
R-16	Oscillator Grid	10000 Ohms, 1 W.	Type GS	Stack.	
R-17	Microphone	1850 Ohms	2"D Type 205 Term.	W.L.	
R-18	Microphone	2200 Ohms	Type 754 Mtg.	W.L.	

TYPE GO CARRIER CURRENT TRANSMITTER-RECEIVER

<u>Symbols</u>	<u>Name</u>	<u>Rating</u>	<u>Designation</u>	<u>Supplier</u>
<u>SAFETY GAP</u>				
SG-1	Protector		Disc S#949357 Mica S#948956	W W
<u>SWITCHES</u>				
S-1	Power	10 A. 250 V.	#3952	Bryant
S-2	Test Button	1 M 1 B	S#511813	W
<u>TRANSFORMERS</u>				
T-1	Output	50-150 KC 275/120 V.	L-340113	W
T-2	Microphone	1:15	L-340176	W
<u>VACUUM TUBES</u>				
V-1 to V-8	Radiotron Beam	For 125 V. Equip.	25-L-6	RCA
V-1 to V-8	Radiotron Beam	For 250 V. Equip.	6-L-6	RCA
V-9	Neon Glow Lamp	2 W. 115 V.	S-14 Clear Med. Screw base	W
<u>VACUUM TUBE SOCKETS</u>				
VS-1 to VS-8	Wafer	Octal.	#6714	Cinch
VS-9	Neon Glow Lamp	Med. Screw	H-715	Bryant
<u>RELAYS</u>				
K-1	Modulation	1 A. 300 V.	Series AQA Spec. Z-6020	A.E.
<u>JACKS</u>				
J-1	Modulation	1 Ckt.	CAT #DC-26	A.E.
J-1A	Modulation	1 Ckt. & 1 Block Ckt.	CAT #DC-27	A.E.
<u>COMMUNICATION HANDSET</u>				
(Not supplied as part of the carrier set equipment)				
HS-1	Telephone Monophone		Spec. Z-6028	A.E.
<u>COMMUNICATION DESK HAND SET</u>				
(To be wired from the switchboard panel per figure 3 - not supplied as part of the Carrier Set Equipment.)				
HS-2	Telephone Monophone & Desk Stand		Spec. Z-7675	A.E.
<p>The Westinghouse Electric and Manufacturing Company is prepared to supply any of the listed parts for use in servicing this equipment. Orders should specify that they are for Type GO Transmitter-Receiver and mention the circuit symbol. All orders must specify the rating as well as the Supplier's designation. Parts indicated as having suppliers other than Westinghouse Electric and Manufacturing Company may be ordered direct from the manufacturers. The addresses are as follows:</p>				
Card	- Allen D. Cardwell Mfg. Co. 81 Prospect St. Brooklyn, N.Y.		Cinch	- Cinch Mfg. Co. 2339 W. Van Buren St. Chicago, Illinois
C-D	- Cornell Dubilier Cond. Corp. South Plainfield, N.J.		Bryant	- Bryant Electric Co. Bridgeport, Conn.
A.E.	- American Automatic Electric Sales Co. 1033 W. Van Buren St. Chicago, Illinois		W-L	- Ward Leonard Electric Co. Mt. Vernon, N.Y.
RCA	- R.C.A. Manufacturing Co. Radiotron Division Harrison, N.J.		Stack	- Stackpole Carbon Co. St. Marys, Pa.
			W	- Westinghouse E.&M. Co.

www.ElectricalFaultManuals.com



APPLICATION

The type GO transmitter-receiver was designed primarily for carrier current relay operation. The relay circuits are arranged so that carrier is transmitted over a line section to prevent the tripping of breakers on external faults. All the carrier equipments on a single line section operate at the same carrier frequency so that when any one or more transmitters are energized, all of the receivers respond.

Besides relaying, the carrier channel may also be used for one other of the following services: telemetering and automatic load control, remote tripping, supervisory control, or voice communication. The connections of the additional equipment required for these services are such that the carrier relays always have control of the channel. The carrier sets are equipped with a plug jack outlet into which a telephone hand set may be plugged for point-to-point voice communication.

CONSTRUCTION AND OPERATION

The type GO carrier transmitter-receiver components are mounted on a vertical panel (figures 1 and 2) are housed in a cabinet for indoor mounting. The sets are identified as follows:

Style #867499 for 100-150 volt d-c. power supply
Style #867500 for 200-300 volt d-c. power supply

These sets contain all the component parts necessary for converting d-c. power into carrier frequency power (50 to 150 kilocycles) for transmission, and also for converting received carrier frequency power into d-c. for relay operation. The transmitter-receiver unit weighs approximately 95 pounds.

The vertical panel is approximately 12 x 32 inches and is hung by trunnions on the right-hand side. It may be swung open or completely removed from the cabinet as desired. Looking at the front of the panel the various instruments and dials are identified by individual name plates and on figure 1 by numbers which designate the component parts in the wiring diagram, figure 3, and throughout the text.

Two shelves extend from the rear of the vertical panel, one near the top and the other near the bottom. A shield panel connects the two shelves and separates the transmitter section on the left side of the panel, figure 2, from the receiver section on the right side of the panel. The location of the various components mounted on the rear of the panels are shown in figure 2. The arrangement of parts provides good heat distribution and accessibility as well as the necessary electrical shielding.

A complete discussion of the operation of vacuum tubes in the transmitter-receiver circuits is beyond the scope of this book and the reader is invited to consult one of the many radio text books if a discussion of the principles involved is desired. Those who are sufficiently interested to pursue such a study will find that the circuits involved in this transmitter-receiver are conventional and that so far as possible they have been simplified by the omission of all unnecessary components. The Colpitts oscillator circuit is so proportioned that one-half of the high frequency voltage output from the plate of the tube is coupled back to the grid for excitation purposes. Since there is no d-c. bias voltage applied to the oscillator tube under transmission conditions, an appreciable amount of grid current flows while this tube is oscillating. However, the same

grid excitation voltage applied to the amplifier tubes causes a negligible amount of grid current because of the fixed d-c. bias provided. The amplifier tubes are, therefore operating in the mode described as Class A operation. It is not necessary for the users of this equipment to be thoroughly familiar with the operation of this circuit, but such a knowledge will aid in securing the best possible operation. Those principles which it is considered essential that the user understand are described in the appropriate section of this book.

The type GO transmitter-receiver connections are shown schematically in figure 3. A single oscillator tube V1 is used to generate carrier frequency voltage which is amplified either by two tubes V3 and V4 in the push-pull circuit, or if desired, by six tubes V3 to V8 in a push-pull parallel connection. The receiver circuit utilizes a single vacuum tube V2. The oscillator tube operates in conjunction with the frequency determining circuits L1, C1, C2 and C3. Direct current grid and plate voltages are supplied through resistor R15 and reactor L3. Capacitor C4 is used to prevent short-circuiting these voltages. The carrier frequency voltages across capacitors C1 and C2 are equal, but of opposite phase, and are applied to the grids of the amplifier tubes through capacitors C5 and C6. The necessary d-c. bias voltage for these grids is supplied through resistors R4 and R5. The sole purpose of resistors R8 to R13 is to prevent undesirable interaction among the amplifier tubes.

The plate circuits of these amplifier tubes are connected to the primary transformer T1 which is an iron-cored transformer operating at carrier frequencies. The secondary of this transformer is designed to supply a resistance load of any value between 50 and 500 ohms. By making the inductive reactance of the reactor and variometer in the line coupling tuner equal to the capacitive reactance of the line coupling capacitor, series resonance is obtained and the load on transformer T1 is a pure resistance.

The secondary of transformer T1 also serves as an auto transformer for the received signals and supplies energy to the primary tuned circuit of the receiver formed by capacitor C8 and inductance L4. This circuit, when properly adjusted, is series resonant. The action of the neon glow protector lamp V9 is primarily to destroy this series resonance when local signals are received so that the voltage across inductance L4 never exceeds approximately 150 volts. The current through the neon glow lamp is limited by the relatively high reactance of capacitor C8.

The receiver secondary circuit consisting of capacitor C9 and inductance L5 delivers the carrier frequency voltage directly to the control grid of vacuum tube V2. This tube V2 normally (stand-by conditions) has a sufficient bias voltage applied between its cathode and its grid so that no plate current flows. A received signal overcomes this bias and causes plate current to flow through the receiver relay. The carrier frequency component in the plate circuit of this tube is by-passed by capacitor C11 and the direct current component passes through milliammeter M2 and the receiver relay to the positive bus.

The potentiometer resistor R1 is used to adjust the oscillator and receiver tube voltages to the proper values. Cathode resistors R6 and R7 automatically provide the proper bias for the amplifier tubes. Milliammeter M1 is used to check the current output of the amplifier tubes. The cathode heater current is read by

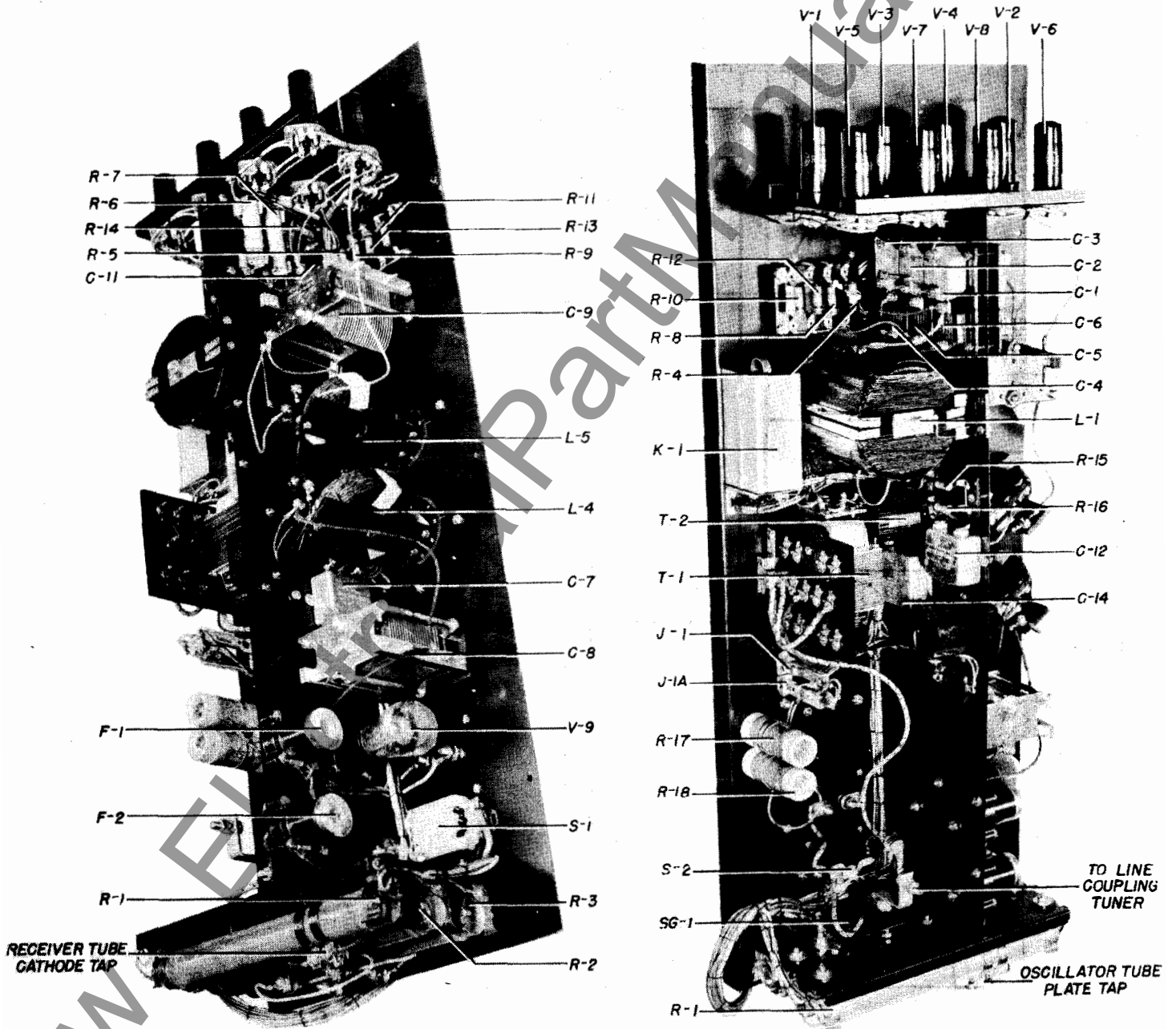

Figure 2
Rear Views of Transmitter-Receiver (Cabinet Removed)

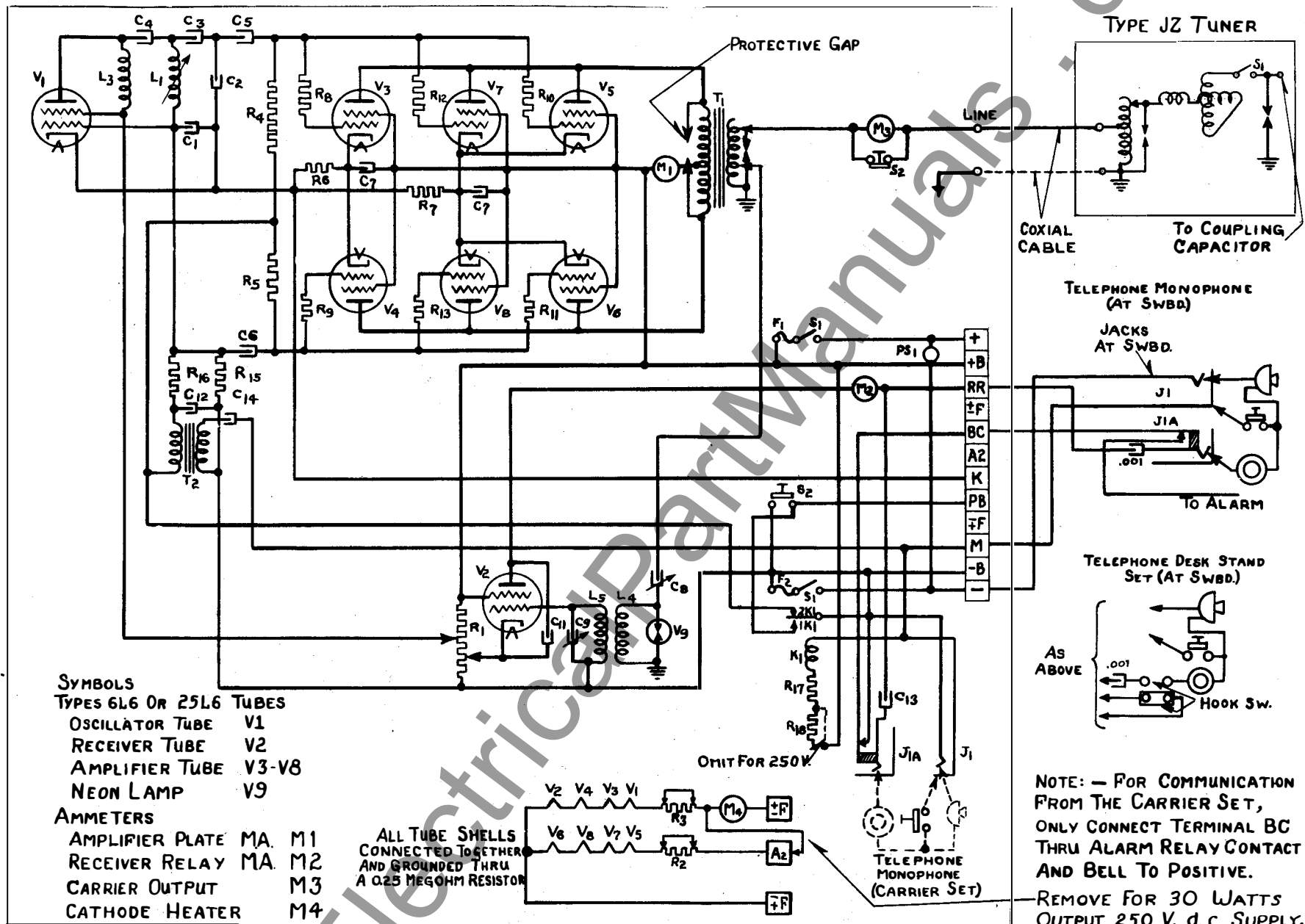
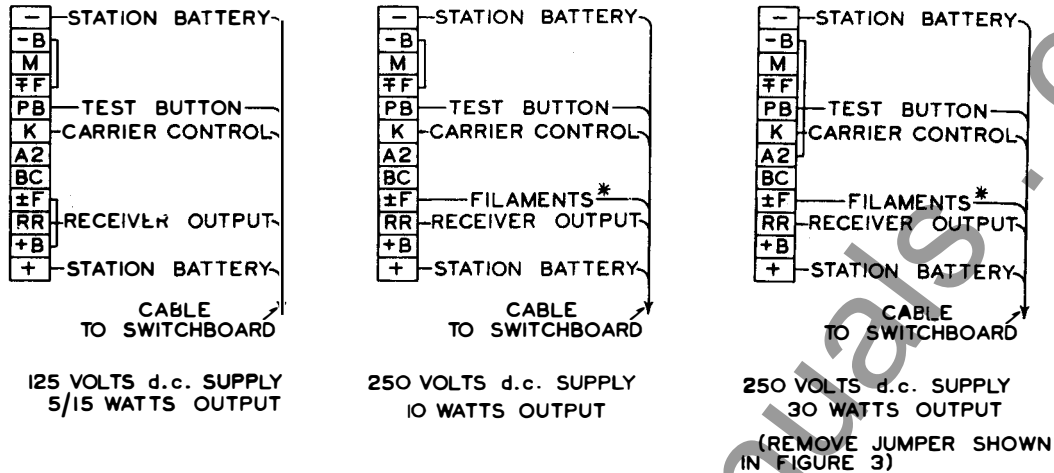

Figure 3

Schematic Internal Wiring of the Transmitter-Receiver (Connections beyond set external connections required for communication).



FOR VOICE COMMUNICATION MAKE THE ADDITIONAL EXTERNAL CONNECTIONS SHOWN IN FIGURE 3.

* CONNECT TO 220 OHM RESISTOR AT SWITCHBOARD THEN TO POSITIVE OF STATION BATTERY.

Figure 4
External D-C. Connections to the Relay Equipment

the ammeter M4, and is adjusted by resistors R2 and R3. These circuits are arranged so that either two or six amplifier (total of either 4 or 8) tubes may be used as required for a specific application. The power output with six amplifier tubes will be approximately three times the value which can be obtained with only two tubes.

Protective gaps as indicated on the diagram are provided to prevent possible damage from lightning or switching surges.

Switch S1 and fuses F1 and F2 completely isolate the equipment from the power supply voltage except that the convenience outlet PS-1 is still energized. Test button S2 is arranged so that it normally shunts carrier output milliammeter M3, but this shunt is removed when the button is pressed to check the transmitter.

Point to Point Voice Communication

Point-to-point voice communication is possible from the carrier set by plugging a telephone hand-set in jacks J1 and J1A. If desired a duplicate set of jacks may be located on the switchboard, or a desk-type telephone set located on the station operator's desk for communication from any of these points, as well as from the carrier set. It should be noted that communication can be carried on from only one location at a time. The connections are shown schematically in figure 3.

The modulating components of the carrier set are the microphone transformer T2; the relay K1; the grid-bias resistor and condenser

R16 and C12; telephone jacks J1 and J1A; relay resistors R17, R18; and condensers C13, C14. In the 100 to 150 volt carrier sets the resistor R18 should be shorted out as shown in figure 3. When communication is desired, the operator plugs his hand-set in jacks J1 and J1A and signals the distant operator by pressing the push button on the telephone set. This starts carrier by energizing relay K1 which closes its contacts 1K1. Contact 1K1 connects negative to the oscillator tube cathode circuit thru terminal K. Starting carrier rings the carrier alarm bell at the distant station. Plugging in the telephone hand-set will disconnect the local alarm bell to prevent it from ringing during communication or when signalling the distant station. This is done by the test jack J1A opening the bell circuit terminals BC to -B. At the completion of the predetermined communication signal the local operator releases his push button on his hand-set. The distant operator plugs in his hand-set and talks to the first operator after closing the push button on the hand-set.

While the initiating operator is talking, the distant operator should listen but not close his hand-set push button. If both operators close the hand-set push button at the same time, communication is difficult because of a heterodyne signal being set up. The speaking operator only should push the hand-set button while talking and when he desires to listen, he should release his push button. Then, the other operator should close his push button and talk.

Closing the hand-set push button also energizes the telephone microphone directly from the station battery thru the relay K1, R17 and R18. The relay contact 2K1 modifies the bias connections of the amplifier tubes by discon-

necting the bias resistors R4 and R5 from -B and connecting them thru the secondary of the microphone transformer T2 to the modulator grid bias resistor R16 and condenser C12. This transfer increases the oscillator tube grid leak to approximately twice its normal value and reduces the oscillator output very slightly in order to produce the necessary bias to the amplifier tube grids. Modulation by the grid bias variation method is then possible. Talking into the microphone sets up voice frequency currents which circulate thru the microphone, condenser C14 and transformer T2 primary circuit. These currents are transformed thru the microphone transformer T2 to modulate the carrier frequency output.

The received signal is demodulated by the receiver tube, V2, and passes thru the handset ear phones from the receiver tube plate thru milliammeter M2 and condenser C13 to -B.

INSTALLATION AND ADJUSTMENT

Installation

The type GO transmitter-receiver equipment as supplied includes an accessory package in addition to the main cabinet. The items received should be carefully checked against the parts list which will be found in a later section of this book and also against the order or requisition for the equipment. Any shortage should be reported immediately to the transportation company, and the nearest district office of the manufacturer. The equipment should be very carefully checked for damaged or missing parts and particular attention should be given to any parts which have become loose in shipment or wires which have broken due to vibration.

The indoor transmitter-receiver set should be mounted in a convenient location which is protected from the weather. It is recommended that the set be mounted in an accessible location and as near to the switchboard as possible in order to reduce the length of leads through the associated relays or other equipment. The cabinet outline is shown in figure 12.

The necessary connections from the transmitter-receiver to the switchboard or power supply are to be made in a suitable conduit installed in the knock-out in the bottom of the transmitter-receiver cabinet. Number 12 gauge wire is recommended for these connections. Before actually making these connections, the detailed installation diagram should be compared with the external connection diagrams of figure 4 to be sure that there is no conflict.

Do not insert any of the tubes or fuses in the transmitter-receiver unit until the following sections dealing with circuit adjustments have been read through very carefully.

Circuit Adjustments

The first consideration when putting this equipment into operation will be the choice of carrier frequency. Prior to shipment, the equipment is very carefully tested and adjusted for operation at 100 kilocycles with a 50 ohm equivalent line resistance, 125 or 250 volt battery, and all eight vacuum tubes.

Tables of adjustment data and curves covering the operation of the equipment under all normal conditions are included as an aid to making adjustments. These tables cover the adjustment of the equipment as shipped from the factory. If conditions in the field differ from the final factory adjustment conditions, it will

be necessary to refer to the curves of figures 5 to 11 and vary the adjustments accordingly. Some of the values in the table should be the same for all installations and, therefore, no curves are given for these quantities. Separate tables are given for 125 volt operation and for 250 volt operation, even though many of the values in both tables are the same. Type 25L6 tubes are to be used for 100 to 150 volt operation and Type 6L6, for 200 to 300 volt operation. During the preliminary adjustments, all eight tubes of the correct type should be used until the equipment is operating satisfactorily. After the adjustments are complete, if it is found that all of the available power is not required, four of the tubes may be removed and certain of the adjustments as indicated below changed accordingly. The connections shown in figure 4 should also be changed if necessary.

The following tabulation gives the type tubes and connections to be used and battery burden for the d-c. supply voltage and radio-frequency outputs shown.

Type No.	Heater Tubes	Conn.	Normal Supply Volts	Battery Load Amperes	Standby:Trans.	Normal Output Watts
25L6	4	Series	125	.362	.506	5
25L6	8	2 groups parallel	125	.662	1.026	15
6L6	4	Series	250	.950	1.097	10
6L6	8	Series	250	.950	1.317	30

Add .050 amperes to transmitting loads above when the communication handset-push-button is closed.

The adjustment procedure will follow the tabulation as closely as possible and, therefore, it is important to become thoroughly familiar with the tables. Five columns are included in these tables: the first column indicates the control, instrument or quantity to be checked; the second column indicates the maximum value which is permissible; the third column indicates the minimum value which is permissible; the fourth column indicates the normal value of the quantity; and the fifth column should be filled in at the time of installation to indicate the actual value which was obtained. This last column is of great importance and should always be filled in just as soon as the equipment is installed. A copy of these values should be kept with the equipment for checking purposes and all letters of inquiry to the manufacturer regarding the operation of this equipment should be accompanied by a copy of this form, with all blanks properly filled.

1. The first line in the adjustment data table is the power supply or battery voltage which is to be measured at the terminals of the equipment by connecting a voltmeter into the convenience outlet PS1, which is marked VOLTAGE. The actual value of this voltage should be entered on the line in the fifth column of the data table. The limits given on these quantities are intended to include the maximum variation in power supply voltage, as indicated. It should be observed that the maximum and minimum variations of the values in the table are not all the same percentage. This means that with the actual normal voltage at PS1, the various circuit components can be adjusted within all the limits given, but once the normal voltage is established, it should not be permitted to fluctuate more than +5%.

2. If the supply voltage is within the limits shown, the fuses and resistors should be

inserted in the equipment but no tube should be placed in any socket until the following tests have been made. In order that these fuses and resistors may function properly, they should be carefully checked against the parts list to see that they are of the correct values as marked. The location of these components is shown in figure 2. The two fuses F1 and F2 are to be mounted in the receptacles FS1 and FS2 which are one above the other. The neon lamp V9 is to be inserted later in the third receptacle VS9. Of the three larger resistors, the highest value resistor R1 (2000 ohms for 100 to 150 volt sets, 5000 ohms for 200 to 300 volt sets) is to be inserted in the clips farthest from the front of the panel. These clips are located on the under side of the bottom shelf on the vertical panel. The other two of the larger size resistors R2 and R3 have the same resistance value (160 ohms for 100 to 150 volt sets, 80 ohms for 200 to 300 volt sets) and are to be inserted in the middle and front positions, respectively. The two small resistors R6 (60 ohms for 100 to 150 volt sets, 120 ohms for 200 to 300 volt sets) and R7 (30 ohms for 100 to 150 volt sets, 60 ohms for 200 to 300 volt sets) are to be inserted in the clips on right-hand side (rear-view) of the shield panel. These clips are directly beneath the upper shelf. The lower resistance value resistor R7 is to be inserted in the clips nearest the front of the panel.

3. The power switch S1 should be closed and, if necessary, the taps on resistor R1 should be adjusted so that the oscillator screen and plate voltage, and the receiver cathode voltage, when measured between terminal -B and the proper taps on this resistor, are approximately as indicated by the next two lines of the adjustment data tables. Battery positive + B is connected to the end of the resistor R1 nearest the hinged edge of the vertical panel. The oscillator screen and plate voltage tap is nearest the +B end of R1. These voltages will be adjusted more accurately after some of the other adjustments have been made, but it is important that the values shown be approximately correct so that the vacuum tubes will not be injured.

4. Next, power switch S1 is to be opened, the neon glow lamp V9 and four tubes are to be inserted in the sockets V1 to V4. These are the four sockets on the upper shield nearest the front of the vertical panel. Power switch S1 is then to be closed again and resistor R3 adjusted to obtain the proper cathode heater current M4 which is to be as indicated in the table. Note that when power switch S1 is first closed, the current will be above normal due to the low resistance of the cold cathodes. Consequently, power should be applied for about 30 seconds before the final current check is made. The external connections for various conditions are shown on figure 4.

5. These same diagrams will apply for the next test which is made by transferring the four tubes already in the front sockets to the rear sockets V5 to V8 inclusive. With the tubes in the rear sockets, the resistor in the middle position R2 is to be adjusted to give the correct value of cathode heater current ammeter M4 as indicated in the table.

6. Next, all eight of the tubes, V1 to V8 inclusive are to be inserted in their sockets and the connections changed per figure 4, if necessary. With this setup, the cathode heater current ammeter M4 is to be checked against the tables.

7. During the above adjustments, the test button S2 should not be pressed, and all cur-

rents other than the cathode heater current should be zero, with the possible exception of the receiver relay current milliammeter M2. If any of the other instruments indicate current, the cause should be determined before proceeding with the test.

8. The receiver cathode tap on resistor R1 should be adjusted and the voltage should be as indicated by the data tables. The data tables indicate the standby receiver relay current, which is a very small value. The limits shown are intended to indicate that this current should be the lowest possible value which will move the pointer on the milliammeter.

9. The next adjustment determines the frequency of the equipment. The adjustment data given in the tables are for a frequency within the limits as indicated. If the frequency to be used is other than 100 kilocycles, the oscillator frequency dial, L1, which controls the carrier frequency transmitted should be changed according to the curve of figure 5. When practical, this frequency should be checked by a wavemeter and the actual value entered in the table.

10. The next adjustment is the receiver primary inductance L4. Either the whole coil should be used or the larger portion of it from the tap to the finish end of the coil. The two curves of figure 6 indicate the effect of this adjustment and show quite clearly that it is of little importance except near the ends of the frequency range. The receiver secondary inductance L5 is identical with L4 and should be adjusted in the same manner. The axes of these coils may be turned so as to form any desired angle with a corresponding value of coupling between them. This coupling is not important as long as the axes of the coil are not coincidental, nor at right angles to each other. Maximum coupling occurs when the axes are coincidental and approaching this adjustment will increase the receiver sensitivity.

11. On the average open-wire transmission line the carrier signal received from the transmitter at the other end of the line is so strong that the location of the receiver tap on transformer T1 is not very critical. The usual location of the receiver tap is between taps 5 and 9. It is only on a weak received signal and for very selective tuning that it is necessary for careful matching of the receiver circuit thru the selection of the receiver tap. Very selective tuning is necessary only where adjacent line sections have carrier frequencies less than 10 kilocycles apart. Where less than 10 kilocycle separations between adjacent lines are required, the manufacturer should be consulted.

12. In order to get maximum carrier frequency transmitter efficiency, it is important to carefully match the impedance of transformer T1 to the impedance of the transmission line, as measured from the line coupling tap. When the line coupling tuner is properly tuned for series resonance these impedances appear as effective resistance. The curves of figure 7 show the relation between this equivalent line resistance and the line coupling taps on transformer T1. For average open-wire transmission lines the equivalent line resistance is about 500 ohms. However, coaxial cable of the type commonly used between the transmitter-receiver and the line coupling tuner has a characteristic impedance of about 50 ohms.

13. The next adjustment is quite important. Figures 8, 9, 10 and 11 show the effect of os-

cillator plate voltage upon the plate currents and output currents. These curves have also been plotted to indicate the product obtained by multiplying the readings of amplifier plate current milliammeter M1 and carrier output milliammeter M3. The object of this adjustment is to obtain a value of oscillator voltage which will result in the maximum of this product. By referring to the curves, it will be seen that as the oscillator plate voltage is increased above a certain value, the amplifier plate current decreases rather rapidly. It will also be noted that the carrier output current does not increase much after a certain oscillator plate voltage is reached. The product of these two currents reaches a maximum under the best operating conditions. Therefore, the oscillator plate voltage tap on resistor R1 is to be moved slightly from its initial adjustment and the readings of the milliammeters M1 and M3 observed and multiplied together as a check for the maximum value of the product. Regardless of installation conditions, the amplifier plate current as read on milliammeter M1 should be within the limits indicated in the data tables, but the carrier output current, as indicated on milliammeter M3, may vary quite considerably from the values given if the equivalent line resistance is other than 50 ohms. This variation in output current will cause the product to vary correspondingly.

CAUTION: Do not attempt this adjustment until the line coupling tuner has been adjusted for resonance.

14. If suitable instruments are available, the oscillator combined plate and screen current should be measured by disconnecting the tap nearest the +B end of R1 and connecting a milliammeter in series with this lead. This test is not particularly important, but it serves as a convenient means of checking the equipment at a later date if trouble develops. However, it is of considerable importance that the oscillator plate and screen voltage be recorded, since this must be within the limits shown in order to insure satisfactory tube life.

15. After the above adjustments are completed, carrier should be transmitted from the remote equipment so that the receiver may be adjusted for maximum receiver relay current indicated by milliammeter M2. The approximate settings for the receiver primary capacitor C8 and the receiver secondary capacitor C9 are indicated by figure 6. It is usually necessary to adjust these capacitors slightly to obtain resonance with the remote signal. It will generally be found impossible to adjust these controls by receiving from the local transmitter, since the signal strength is so great that the receiver will tune very broadly. As a matter of fact the values shown by the curve are much more accurate than the settings which may be obtained using the local transmitter. When the remote signal has been tuned in, the receiver relay current milliammeter M2 should be recorded and then the test button S2 pressed, and this current again recorded for the local transmission condition. This completes the adjustment of the equipment for normal conditions and all of the blanks in the fifth column of the adjustment data table should be filled in before leaving the equipment. It is desirable to repeat the above adjustments two or three times in order to be sure that the best settings have been obtained.

On rare occasions the noise level on the transmission lines due to line-switching disturbances or interference from other carrier sets may be great enough to increase the receiver plate current above the pick-up value of the receiver relay element. This interference may

be reduced in either of two ways, or by a combination of both.

1. By reducing the coupling between L4 and L5 to near its minimum value. (Minimum coupling occurs when the coil axes are at right angles.)

2. By increasing the receiver tube cathode voltage. The cathode voltage is increased by moving the receiver tap on resistor R1 toward the +B end of the resistor. This reduction of interference is a matter of trial and error. As both the desired signal and interference signal are reduced by these adjustments, care should be taken that the desired signal is not reduced below a safe operating value of the receiver relay element.

OPERATION

When this equipment is properly installed and adjusted, it may be placed in operation by closing the safety disconnect switch in the line coupling tuner and power switch S1. The transmission of carrier is automatically controlled by the associated relays and requires no attention on the part of the operator except maintenance, as explained in a separate section. The equipment may be taken out of service at any time by opening the power and disconnect switches, in which case, there is no power consumed from the supply source and no appreciable deterioration of the equipment over long period of time.

In connection with the installation and maintenance of this equipment, several instruments which are not ordinarily used for 60 cycle measurements, such as a cathode ray oscilloscope, several thermocouple voltmeters and ammeters, a multi-scale high resistance d-c. voltmeter having at least 1000 ohms per volt, a multi-scale d-c. milliammeter, a suitable tube checker, and a wavemeter for carrier frequency will be found very helpful.

MAINTENANCE

After installation, the equipment should be inspected daily for the first week or two to see that it functions properly and that nothing overheats. This procedure will permit the operators to become familiar with the equipment. After the first two weeks, a careful inspection once every week will be sufficient. When these weekly inspections are made, all meter readings should be recorded.

Vacuum Tubes

If any discrepancy of the meter readings is noticed after a considerable period of operation, all of the vacuum tubes should be checked to see that they are still in good condition. Occasionally, a defective tube will appear within the first month of operation. In general, no tube trouble should be experienced after this period until the useful life of the vacuum tube has expired. Owing to the wide variation in the activity of the equipment, it is impossible to state how long the vacuum tubes may be expected to operate. If a standard type of tube checker is used for testing the vacuum tubes, the limits which are given in the instruction book covering its use will usually be found satisfactory. If no tube checker is available, it will be found satisfactory to check each of the questionable tubes in the oscillator socket V51 which is in the front right-hand corner of the tube shelf. In making this test, tubes which are known to be satisfactory should be inserted in all of the other sockets and the carrier frequency current into the line coupling capacitor should be observed for the

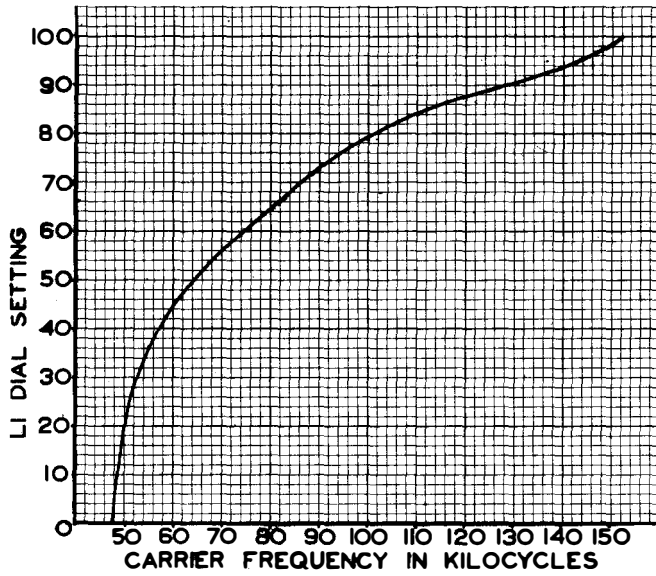

Figure 5
Frequency Calibration Curve of the Oscillator

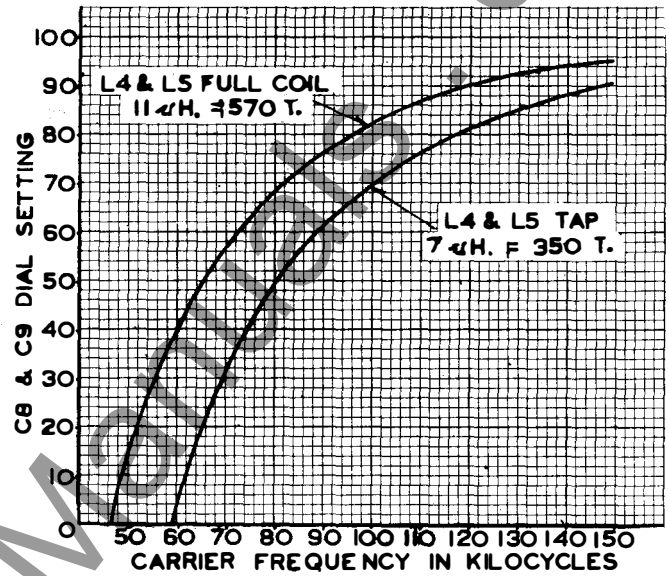

Figure 6
Frequency Calibration Curve of the Receiver

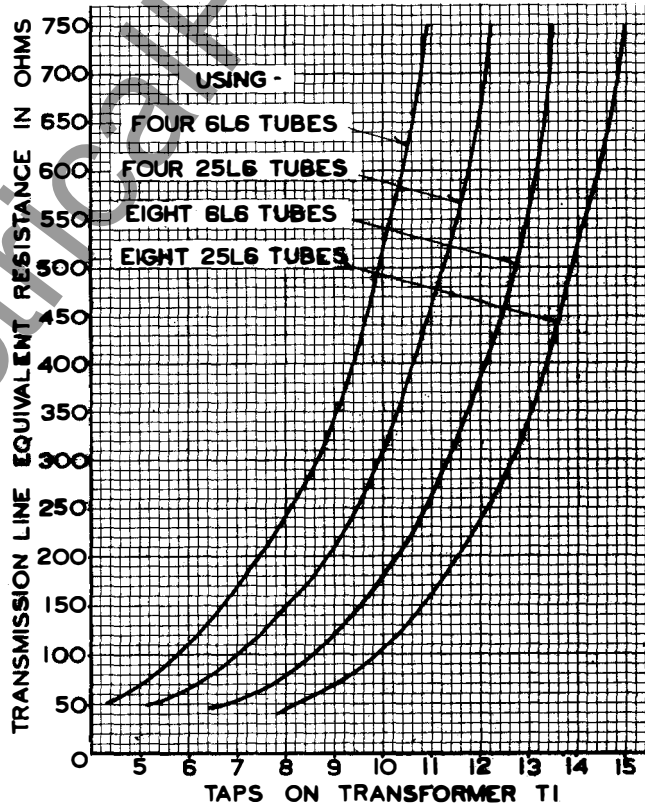

Figure 7
Curve for Matching Transformer T1 to the Equivalent Resistance of the Transmission Line from the Transmitter-Receiver to the Line Coupling Tuner.

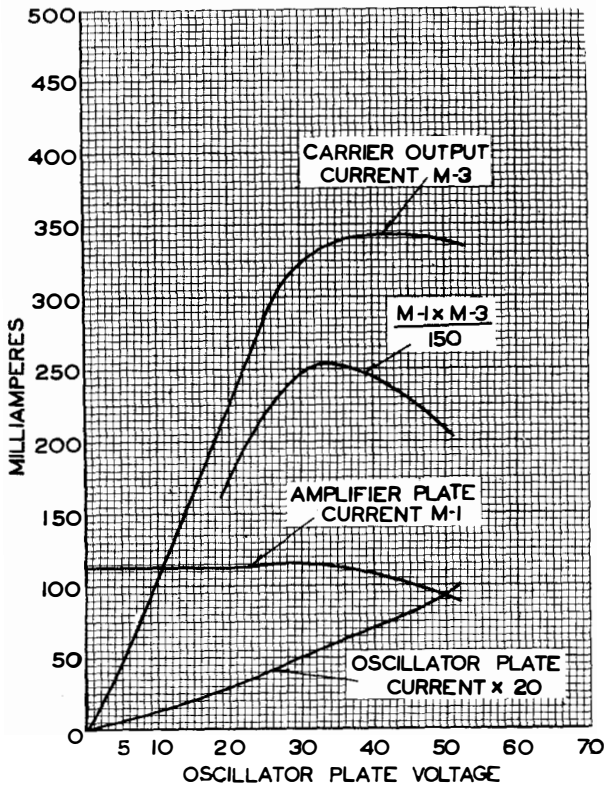

Figure 8
Oscillator Output Characteristics Using Four Type 25L6 Tubes (50 ohm load).

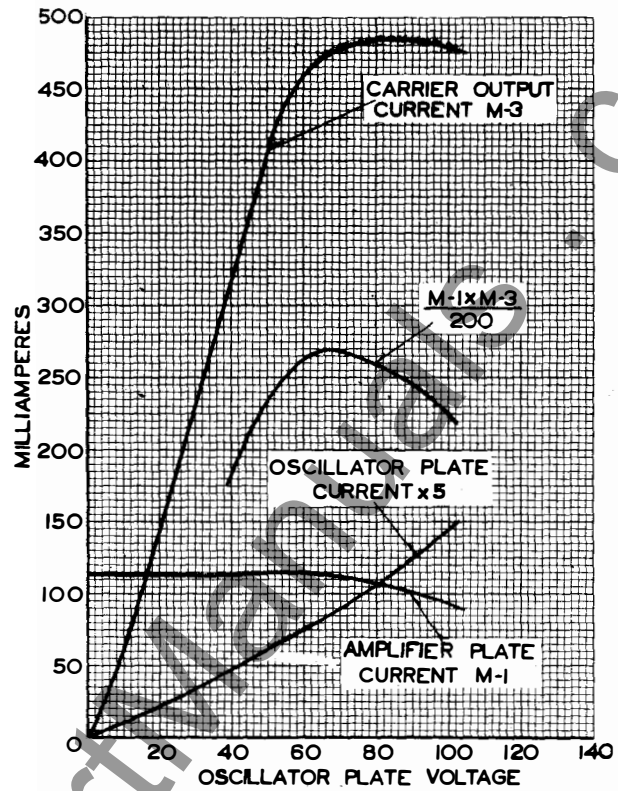

Figure 9
Oscillator Output Characteristics Using Four Type 6L6 Tubes (50 ohm load).

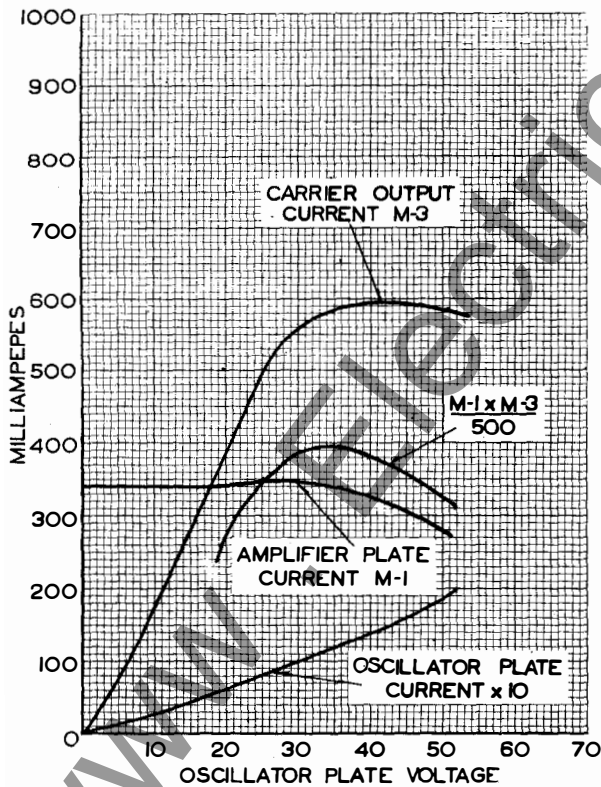

Figure 10
Oscillator Output Characteristics Using Eight Type 25L6 Tubes (50 ohm load).

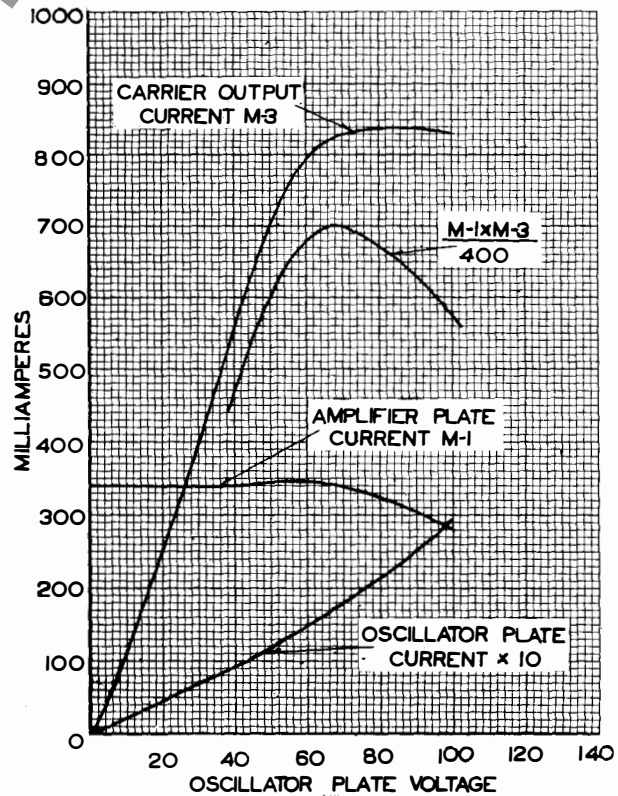

Figure 11
Oscillator Output Characteristics Using Eight Type 6L6 Tubes (50 ohm load).

TYPE GO CARRIER CURRENT TRANSMITTER-RECEIVER

normal oscillator plate voltage which is used. A tube which does not oscillate after applying normal heater current for one minute will be considered unsatisfactory. Also, a tube which, used as an oscillator does not permit the equipment to deliver approximately full power output should be replaced. No definite end limits can be given because of the wide variations in transmission efficiencies of various lines. On short or low loss lines, tubes can be used which would be too weak for use on long or high loss lines.

At the end of each year of operation, the vacuum tubes should be removed from their sockets and their contacts inspected for possible dirt or corrosion. If there is any discoloration, it may be removed by the use of very fine sandpaper. In order to insure maximum tube life, it is very important that the resistance of these contacts be kept to an absolute minimum. If necessary, this cleaning operation should be performed more frequently than indicated above.

Fuses

Since the fuses in this equipment are primarily intended to protect only against short circuits or very severe overloads, they will probably never fail during the life of the equipment. It is desirable that they be removed at the end of each year of operation and that any corrosion which may have occurred, be removed by the use of fine sandpaper.

Resistors

As in the case of other components, the resistors are operated well within their rating and should not fail during the life of the equipment. It is desirable that they be removed from their clips at the end of each year of operation, and that any corrosion which may have occurred be removed by the use of fine sandpaper.

Instruments

At the end of each year's operation, the zero adjustments of all instruments should be checked. If facilities are available for checking the cathode heater ammeter M4 against a suitable standard, this should be done at the end of each year's operation. This calibration must be made with the meter mounted on a 3/32 inch steel panel as in the transmitter-receiver assembly. The accuracy of the other instruments is not considered of sufficient importance to warrant such calibration unless it is known that they have been seriously overloaded, or their indication is believed, for some other reason, to be incorrect.

PARTS LISTS

Shipping Lists for Type GO Transmitter-
Receivers

Style 867499 covers equipment for 100 to 150 volts D.C. supply. It is identified as DL-7501950 G-48 and includes:

1 Transmitter-Receiver DL-7501950 G-47

1 Accessories Package DL-7501950 G-50 which includes :

- 16 - R.C.A. Radiotrons type 25-L-6, Symbol V-1 to V-8
- 2 - Neon Glow Lamps 2 Watts 115 Volts S-14 Clear Med. Screw Base, Symbol V-9
- 4 - Fuses 6 Amp. 125 V. Bryant Type POR-6, Symbol F-1 & F-2

- 1 - Resistor 2000 Ohms, 200 Watts, Symbol R-1
- 2 - Resistors 160 Ohms, 200 Watts, Symbols R-2, R-3
- 1 - Resistor 60 Ohms, 12 Watts, Symbol R-6
- 1 - Resistor 30 Ohms, 12 Watts, Symbol R-7
- 1 - Name Plate #19914

Style 867500 covers equipment for 200-300 volt D.C. supply. It is identified as DL-7501950 G-49 and includes:

1 Transmitter-Receiver DL-7501950 G-47

1 Accessories Package DL-7501950 G-51 which includes:

- 8 - RCA Radiotrons, Type 6-L-6, Symbols V-1 to V-4
- 2 - Neon Glow Lamps, 2 W. 115 V. S-14 Clear Med. Screw base, Symbol V-9
- 4 - Fuses 6 Amp. 250 V. Bryant #7054 & Casing #1915, Symbols F-1 & F-2
- 1 - Resistor 5000 Ohms, 200 W. Symbol R-1
- 2 - Resistors, 80 Ohms, 200 W. Symbols R-2, R-3
- 1 - Resistor, 130 Ohms, 12 W. Symbol R-6
- 1 - Resistor, 60 Ohms, 12 W. Symbol R-7
- 1 - Name Plate #19914
- 1 - Resistor Assembly, 4 of 880 ohms W-L 8-1/2 inch D Type 204 Terminals, type 721 mounting in parallel for 220 Ohms total.

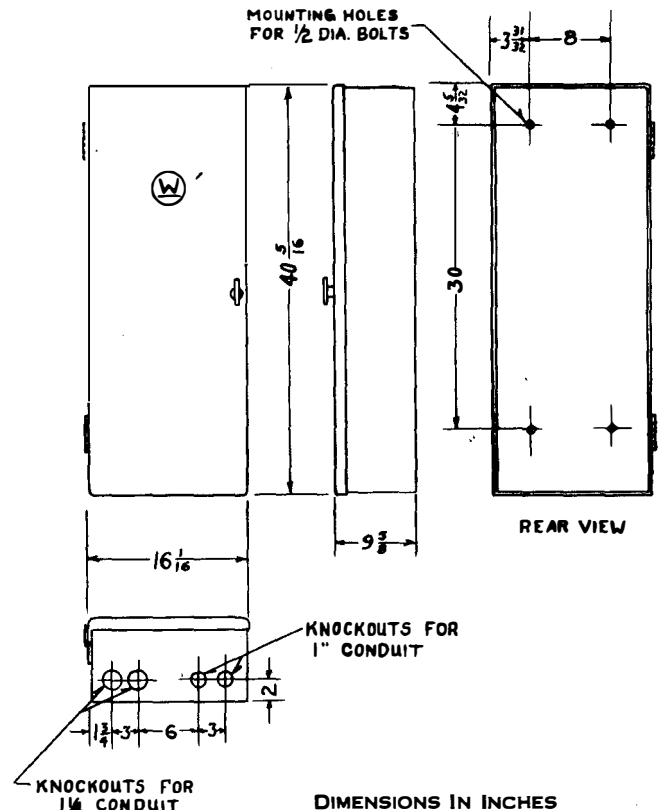

Figure 12
Outline and Drilling Plan for the Transmitter-
Receiver Cabinet.

TYPE 60 CARRIER CURRENT TRANSMITTER-RECEIVER

ADJUSTMENT DATA FOR 100-150 VOLT EQUIPMENT (FOUR OR EIGHT TYPE 25L6 TUBES)

See Text of instruction book for detailed discussion of following table.
Numbers preceding data refers to text paragraph numbers.

	Max.	Min.	Norm.	Actual
1. With Power Switch S-1 off				
Volts Battery (Power Supply) Voltage Outlet PS-1.....	150	100	125	_____
2. With Fuses and Resistors but no Tubes in any Socket				
3. Switch S-1 on				
Volts Oscillator Screen & Plate -B to tap on R-1 (approximate adjustment)..	44	26	35	_____
Volts Receiver Tube Cathode -B to tap on R-1 (approximate adjustment)..	25	15	20	_____
4. With Neon Glow Lamp V-9 and Four Front Tubes V-1 to V-4 in Sockets				
Adjust R-3 for Amperes Cathode Heater Current M-4.....	.296	.268	.282	_____
5. With Front Tubes Out and Four Rear Tubes V-5 to V-8 in Sockets				
Adjust R-2 for Amperes Cathode Heater Current M-4 (For Four Tube Operation)..	.296	.268	.282	_____
6. With all Eight Tubes V-1 to V-8 in Sockets - Adjust R-2 for Amperes				
Cathode Heater Current M-4 (For Eight Tube Operation).....	.592	.535	.564	_____
7. With Test Button S-2 Open, M-1 and M-3 Must Be Zero				
8. Adjust Receiver Cathode Tap on R-1 for Milliamps. Receiver Relay M-2.	.10	.01	.05	_____
Volts Receiver Tube Cathode -B to tap on R-1 (final adjustment).....	25	15	20	_____
9. Adjust to Desired Frequency Referring to Curves - Data below are for				
*9. Frequency in Kilocycles.....	101	99	100	_____
9. Oscillator Frequency Dial L-1.....	85	75	80	_____
# Equivalent Line Resistance in Ohms.....	55	45	50	_____
*10. Receiver Primary Winding L-4.....	Total	Tap	Total	_____
*10. Receiver Secondary Winding L-5.....	Total	Tap	Total	_____
10. Receiver Primary Axis L-4.....	100	75	88	_____
10. Receiver Secondary Axis L-5.....	100	75	88	_____
#11. Receiver Primary C-8 Tap on T-1 (For Four Tube Operation).....	7	6	6	_____
#11. Receiver Primary C-8 Tap on T-1 (For Eight Tube Operation).....	9	8	8	_____
#12. Output Tap on T-1 (For Four Tube Operation).....	7	5	6	_____
#12. Output Tap on T-1 (For Eight Tube Operation).....	10	8	9	_____
13. Adjust Oscillator Plate Voltage Tap on R-1 for Maximum Product of				
Amplifier Plate Current times Carrier Output Current M-1 x M-3.....				
Milliamps. Amplifier Plate Current M-1 (For Four Tube Operation).....	133	87	113	_____
Milliamps. Amplifier Plate Current M-1 (For Eight Tube Operation).....	400	260	340	_____
#Milliamps. Carrier Output Current M-3 (For Four Tube Operation).....	390	300	340	_____
#Milliamps. Carrier Output Current M-3 (For Eight Tube Operation).....	670	510	585	_____
#Product M-1 x M-3 ÷ 150 (For Four Tube Operation).....	375	165	250	_____
#Product M-1 x M-3 ÷ 500 (For Eight Tube Operation).....	600	270	400	_____
14. Disconnect Tap on R-1 nearest hinged edge of Panel and insert				
Milliammeter				
*Milliamps. Oscillator Plate and Screen.....	21	8.5	14	_____
*Volts Oscillator Plate & Screen -B to Tap on R-1 (final adjustment).....	55	20	35	_____
15. With Carrier from Remote Transmitter, Adjust Receiver for Maximum				
Receiver Relay Current M-2.				
*Receiver Primary Capacitor Dial C-8.....	87	77	82	_____
*Receiver Secondary Capacitor Dial C-9.....	87	77	82	_____
Milliamps. Receiver Relay current M-2 (Remote Transmitter Test).....	30	10	15	_____
15. With Test Button S-2 Closed.				
Milliamps. Receiver Relay Current M-2 (Local Transmitter Test).....	35	10	22	_____
Repeating 13 to 15 readings above with Handset HS-1 in Jacks J1 and J1A and				
Handset Button Pressed closed.				
Milliamps. Amplifier Current M-1 (For Four Tube Operation).....	106	70	88	_____
Milliamps. Amplifier Current M-1 (For Eight Tube Operation).....	310	210	260	_____
#Milliamps. Carrier Output Current M-3 (For Four Tube Operation).....	310	235	270	_____
#Milliamps. Carrier Output Current M-3 (For Eight Tube Operation).....	525	400	460	_____
#Product M-1 x M-3 ÷ 150 (For Four Tube Operation).....	250	110	167	_____
#Product M-1 x M-3 ÷ 500 (For Eight Tube Operation).....	400	180	267	_____
Milliamps. Receiver Relay Current M-2 (Local Transmitter Test).....	28	10	18	_____
Volts Extra Modulator Bias across C-12.....	14	10	12	_____
Milliamps. Total Load on Battery, Standby (For Four Tube Operation).....			362	_____
Milliamps. Total Load on Battery, Standby (For Eight Tube Operation).....			662	_____
Milliamps. Total Load on Battery, Transmitting (For Four Tube Operation)...			506	_____
Milliamps. Total Load on Battery, Transmitting (For Eight Tube Operation)..			1026	_____
Add 50 Milliampere to Transmitting loads above when the communication hand				
set push-button is closed.				

* These values vary with frequency. See Curves.
These values vary with equivalent line resistance. See Curves.

TYPE GO CARRIER CURRENT TRANSMITTER-RECEIVER

ADJUSTMENT DATA FOR 200-300 VOLT EQUIPMENT (FOUR OR EIGHT TYPE 6L6 TUBES)
 See Text of instruction book for detailed discussion of following table.
 Numbers preceding data refer to text paragraph numbers.

	Max.	Min.	Norm.	Actual
1. With Power Switch S-1 off				
Volts Battery (Power Supply) Voltage Outlet PS-1.....	300	200	250	_____
2. With Fuses and Resistors but no Tubes in any Socket.....				
3. Switch S-1 on				
Volts Oscillator Screen & Plate -B to tap on R-1 (approximate adjustment)...	88	52	70	_____
Volts Receiver Tube Cathode -B to tap on R-1 (approximate adjustment)...	50	30	40	_____
4. With Neon Glow Lamp V-9 and Four Front Tubes V-1 to V-4 in Sockets				
Adjust R-3 for Amperes Cathode Heater Current M-4.....	.888	.804	.845	_____
5. With Front Tubes Out and Four rear Tubes V-5 to V-8 in Sockets				
Adjust R-2 for Amperes Cathode Heater Current M-4 (For Four Tube Operation).	.888	.804	.846	_____
6. With all Eight Tubes V-1 to V-8 in Sockets - Adjust R-2 for Amperes Cathode Heater Current M-4 (For Eight Tube Operation).....	.888	.804	.846	_____
7. With Test Button S-2 Open, M-1 and M-3 Must Be Zero				
8. Adjust Receiver Cathode Tap on R-1 for Milliamps, Receiver Relay M-2	.10	.01	.05	_____
Volts Receiver Tube Cathode -B to tap on R-1 (final adjustment).....	50	30	40	_____
9. Adjust to Desired Frequency Referring To Curves - Data below are for				
*9. Frequency in Kilocycles.....	101	99	100	_____
9. Oscillator Frequency Dial L-1.....	85	75	80	_____
# Equivalent Line Resistance in Ohms.....	55	45	50	_____
*10. Receiver Primary Winding L-4.....	Total	Tap	Total	_____
*10. Receiver Secondary Winding L-5.....	Total	Tap	Total	_____
10. Receiver Primary Axis L-4.....	100	75	88	_____
10. Receiver Secondary Axis L-5.....	100	75	88	_____
#11. Receiver Primary C-8 Tap on T-1 (For Four Tube Operation).....	6	5	5	_____
#11. Receiver Primary C-8 Tap on T-1 (For Eight Tube Operation).....	8	7	7	_____
#12. Output Tap on T-1 (For Four Tube Operation).....	6	5	5	_____
#12. Output Tap on T-1 (For Eight Tube Operation).....	8	6	7	_____
13. Adjust Oscillator Plate Voltage Tap on R-1 for Maximum Product of Amplifier Plate Current times Carrier Output Current M-1 x M-3				
Milliamps. Amplifier Plate Current M-1 (For Four Tube Operation).....	133	87	113	_____
Milliamps. Amplifier Plate Current M-1 (For Eight Tube Operation).....	400	260	340	_____
#Milliamps. Carrier Output Current M-3 (For Four Tube Operation).....	550	400	475	_____
#Milliamps. Carrier Output Current M-3 (For Eight Tube Operation).....	950	700	825	_____
#Product M-1 x M-3 ÷ 200 (For Four Tube Operation).....	380	180	270	_____
#Product M-1 x M-3 ÷ 400 (For Eight Tube Operation).....	900	500	700	_____
14. Disconnect Tap on R-1 nearest hinged edge of Panel and insert Milliammeter				
*Milliamps. Oscillator Plate and Screen.....	27	10	17	_____
*Volts Oscillator Plate & Screen -B to Tap on R-1 (final adjustment).....	110	40	70	_____
15. With Carrier from Remote Transmitter, Adjust Receiver for Maximum Receiver Relay Current M-2.				
*Receiver Primary Capacitor Dial C-8.....	87	77	82	_____
*Receiver Secondary Capacitor Dial C-9.....	87	77	82	_____
Milliamps. Receiver Relay Current M-2 (Remote Transmitter Test).....	30	10	15	_____
15. With Test Button S-2 Closed.				
Ml. iamps. Receiver Relay Current M-2 (Local Transmitter Test).....	35	10	22	_____
Repeating 13 to 15 readings above with Handset HS-1 in Jacks J1 and J1A and Handset Button pressed closed.				
Milliamps. Amplifier Current M-1 (For Four Tube Operation).....	106	70	88	_____
Milliamps. Amplifier Current M-1 (For Eight Tube Operation).....	310	210	260	_____
#Milliamps. Carrier Output Current M-3 (For Four Tube Operation).....	440	320	380	_____
#Milliamps. Carrier Output Current M-3 (For Eight Tube Operation).....	760	560	660	_____
#Product M-1 x M-3 ÷ 200 (For Four Tube Operation).....	250	120	180	_____
#Product M-1 x M-3 ÷ 400 (For Eight Tube Operation).....	600	330	470	_____
Milliamps. Receiver Relay Current M-2 (Local Transmitter Test).....	28	10	18	_____
Volts Extra Modulator Bias across C-12.....	18	14	16	_____
Milliamps. Total Load on Battery, Standby (For Four Tube Operation).....			950	_____
Milliamps. Total Load on Battery, Standby (For Eight Tube Operation).....			950	_____
Milliamps. Total Load on Battery, Transmitting (For Four Tube Operation)....			1097	_____
Milliamps. Total Load on Battery, Transmitting (For Eight Tube Operation)...			1317	_____
Add 50 Milliampere to Transmitting loads above when the communication handset push-button is closed.				

* These values vary with frequency. See Curves.
 # These values vary with equivalent line resistance. See Curves.

TYPE GO CARRIER CURRENT TRANSMITTER-RECEIVER

COMPONENT PARTS OF TYPE GO TRANSMITTER-RECEIVERS

<u>Symbols</u>	<u>Name</u>	<u>Rating</u>	<u>Designation</u>	<u>Supplier</u>
<u>CAPACITORS</u>				
C-1	Oscillator Tank	.02 Mfd. 600 WV	Type 9H-11020	C-D
C-2	Oscillator Tank	.02 Mfd. 600 WV	Type 9H-11020	C-D
C-3	Oscillator Tank	.02 Mfd. 600 WV	Type 9H-11020	C-D
C-4	Oscillator Plate	.025 Mfd. 600 WV	Type 9-11025	C-D
C-5	Amplifier Grid	.0005 Mfd. 600 WV	Type 9-13050	C-D
C-6	Amplifier Grid	.0005 Mfd. 600 WV	Type 9-13050	C-D
C-7	Cathode By-pass	2 x .25 Mfd. 500 W.V	Type HC-1075	C-D
C-8	Receiver Primary	.001 Mfd.	Type XR-1000 PS Mycalex Ins.	Card
C-9	Receiver Secondary	.001 Mfd.	Type XR-1000 PS Mycalex Ins.	Card
C-11	Receiver Plate	.005 Mfd. 600 WV	Type 9-11050	C-D
C-12	Bias Filter	.5 Mfd. 400 WV	Type HC-3217-1	C-D
Q-13	Rec. Speech Filter	.001 Mfd. 600 WV	Type 4-12010	C-D
C-14	Microphone By-pass	.5 Mfd. 400 WV	Type HC-3217-1	C-D
<u>FUSES</u>				
F-1	(For 125V Equip.) Plug	6 A. 125 V.	POR-6	Bryant
F-2	(For 125V Equip.) Plug	6 A. 125 V.	POR-6	Bryant
F-1	(For 250V Equip.) Cartridge	6 A. 250 V.	#7054 & Casing #1945	Bryant
F-2	(For 250V Equip.) Cartridge	6 A. 250 V.	#7054 & Casing #1945	Bryant
<u>FUSE SOCKETS</u>				
FS-1	Receptacle	Med. Screw	H-715	Bryant
FS-2	Receptacle	Med. Screw	H-715	Bryant
<u>INDUCTANCES</u>				
L-1	Oscillator Variometer	.17-1.7 M.H.	Dwg. 7605336G-1	W
L-3	Plate Reactor	50. M.H.	L-332757	W
L-4	Receiver Primary	11. M.H.	Dwg. 7406582 G-1	W
L-5	Receiver Secondary	11. M.H.	Dwg. 7406582 G-1	W
<u>METERS</u>				
M-1	Amplifier Plate	500 MA	Type UX-35 S#1007168*	W
M-2	Receiver Relay	50 MA	Type UX-35 S#1007159*	W
M-3	Carrier Output	1.0 Amp.	Type UT-35 S#1159644*	W
M-4	Cathode Heater	1.0 Amp.	Type UX-35 S#1007040*	W
*Calibrated for use on 3/32 inch thick Steel Panel.				
<u>PLUG SOCKET</u>				
PS-1	Convenience Outlet	10 A. 250 V.	#4725	Bryant
<u>RESISTORS</u>				
R-1	Potentiometer	For 125V Equip. 2000 Ohms	8-1/2" D Bare Side 2-604 Bands Type 307 Ferrules Type GS Type GS 1-3/8" T Type 300 Ferrules Type GS Type GS Type GS 2" D Type 205 Term. Type 754 Mtg.	W.L.
R-1	Potentiometer	For 250V Equip. 5000 Ohms		W.L.
R-2	Cathode Heater	For 125V Equip. 160 Ohms		W.L.
R-2	Cathode Heater	For 250V Equip. 80 Ohms		W.L.
R-3	Cathode Heater	For 125V Equip. 160 Ohms		W.L.
R-3	Cathode Heater	For 250V Equip. 80 Ohms		W.L.
R-4	Amplifier Grid	50,000 Ohms 1 W.		Stack.
R-5	Amplifier Grid	50,000 Ohms 1 W.		Stack.
R-6	Amplifier Cathode	For 125V Equip. 60 Ohms		W.L.
R-6	Amplifier Cathode	For 250V Equip. 120 Ohms		W.L.
R-7	Amplifier Cathode	For 125V Equip. 30 Ohms		W.L.
R-7	Amplifier Cathode	For 250V Equip. 60 Ohms		W.L.
R-8 to R-13	Parasitic	1000 Ohms, 1W.		Stack
R-15	Oscillator Grid	10000 Ohms, 1 W.	Stack.	
R-16	Oscillator Grid	10000 Ohms, 1 W.	Stack.	
R-17	Microphone	1850 Ohms	W.L.	
R-18	Microphone	2200 Ohms	W.L.	

TYPE GO CARRIER CURRENT TRANSMITTER-RECEIVER

<u>Symbols</u>	<u>Name</u>	<u>Rating</u>	<u>Designation</u>	<u>Supplier</u>
<u>SAFETY GAP</u>				
SG-1	Protector		Disc S#949357 Mica S#948956	W W
<u>SWITCHES</u>				
S-1	Power	10 A. 250 V.	#3952	Bryant
S-2	Test Button	1 M 1 B	S#511813	W
<u>TRANSFORMERS</u>				
T-1	Output	50-150 KC 275/120 V.	L-340113	W
T-2	Microphone	1:15	L-340176	W
<u>VACUUM TUBES</u>				
V-1 to V-8	Radiotron Beam	For 125 V. Equip.	25-L-6	RCA
V-1 to V-8	Radiotron Beam	For 250 V. Equip.	6-L-6	RCA
V-9	Neon Glow Lamp	2 W. 115 V.	S-14 Clear Med. Screw base	W
<u>VACUUM TUBE SOCKETS</u>				
VS-1 to VS-8	Wafer	Octal.	#6714	Cinch
VS-9	Neon Glow Lamp	Med. Screw	H-715	Bryant
<u>RELAYS</u>				
K-1	Modulation	1 A. 300 V.	Series AQA Spec. Z-6020	A.E.
<u>JACKS</u>				
J-1	Modulation	1 Ckt.	CAT #DC-26	A.E.
J-1A	Modulation	1 Ckt. & 1 Block Ckt.	CAT #DC-27	A.E.
<u>COMMUNICATION HANDSET</u>				
(Not supplied as part of the carrier set equipment)				
HS-1	Telephone Monophone		S#1268027	W
<u>COMMUNICATION DESK HAND SET</u>				
(To be wired from the switchboard panel per figure 3 - not supplied as part of the Carrier Set Equipment.)				
HS-2	Telephone Monophone & Desk Stand		S#1268028	W
<p>The Westinghouse Electric and Manufacturing Company is prepared to supply any of the listed parts for use in servicing this equipment. Orders should specify that they are for Type GO Transmitter-Receiver and mention the circuit symbol. All orders must specify the rating as well as the Supplier's designation. Parts indicated as having suppliers other than Westinghouse Electric and Manufacturing Company may be ordered direct from the manufacturers. The addresses are as follows:</p>				
Card	- Allen D. Cardwell Mfg. Co. 81 Prospect St. Brooklyn, N.Y.		Cinch	- Cinch Mfg. Co. 2339 W. Van Buren St. Chicago, Illinois
C-D	- Cornell Dubilier Cond. Corp. South Plainfield, N.J.		Bryant	- Bryant Electric Co. Bridgeport, Conn.
A.E.	- American Automatic Electric Sales Co. 1033 W. Van Buren St. Chicago, Illinois		W-L	- Ward Leonard Electric Co. Mt. Vernon, N.Y.
RCA	- R.C.A. Manufacturing Co. Radiotron Division Harrison, N.J.		Stack	- Stackpole Carbon Co. St. Marys, Pa.
			W	- Westinghouse E.&M. Co.

www.ElectricalArtManuals.com



Westinghouse

SLEET DETECTION EQUIPMENT FOR TYPE GO CARRIER CURRENT TRANSMITTER-RECEIVER INDOOR OR OUTDOOR MOUNTING

INSTRUCTIONS

These instructions are supplementary to I.L. 41-640 for the Outdoor Type Sets and to I.L. 41-641 for the Indoor Type Sets and concern the addition of sleet-detecting equipment.

A sleet indication is obtained by reducing the normal received signal so that the carrier receiver tube operates at the top of the linear slope of its curve. This means that any further decrease in the received signal because of sleet formation on the protected transmission line is indicated by a reduction in the receiver plate milliammeter (M2) reading. For sleet detection it is necessary for the operator at the distant station to send carrier over the transmission line by pressing his Test Push Button either at the carrier set or at the switchboard panel. At the same time the local operator must press the Sleet Detection Push Button on his switchboard panel, and compare the receiver plate milliammeter (M2) with a previous reading taken during normal operation without sleet conditions.

1. The modifications made in the carrier set consist in the addition of a contactor switch relay (CS) operated by the Sleet Detection Push Button thru an additional terminal on the carrier set marked S. This relay is energized by 125 V. d-c thru a series resistor of 2000 ohms (5000 ohms for 250 V. d-c). The normally closed contact of the CS relay and an adjustable 20,000 ohm resistor in parallel are connected in the primary of the receiver tube control grid circuit. During normal operation this back contact shorts out the resistor and the performance is as described in the standard instruction book. During the period when the Sleet Detection Push Button is depressed, the CS

relay contact is open and the 20,000 ohm resistance is inserted in the receiver grid circuit to reduce the received signal.

2. After installation, the 20,000 ohm resistor should be adjusted to reduce the receiver plate current to the proper value to detect sleet. This is determined by slowly increasing the resistance from zero ohms, and watching the detector tube plate current. It will gradually decrease a few milliamperes at first, then suddenly drop off more rapidly. The proper adjustment is the point where the rapid drop begins. This adjustment should be made on a clear dry day when there is no possibility of sleet or excessive moisture.

Sleet detector readings should be taken frequently to determine if there are variations due to factors other than sleet. In this way, sufficient information can be obtained to properly interpret readings obtained during normal or sleet conditions.

3. The adjustments on the CS relay are as follows: Adjust the two nuts on the bottom of the fixed shaft so that the plunger has 1/8 inch travel after the lower contact makes. The plunger should have 1/64 inch travel in the opposite direction after the upper contacts make. This adjustment can be made by screwing down the core screw on top of the switch until the upper contacts are just able to make as the plunger hits the upper stop. Then back off this screw 1/2 turn and lock in place. The element should pick up at 75 volts for a 125 V. set, and 150 volts for a 250 V. set. Its coil resistance is 1160 ohms.

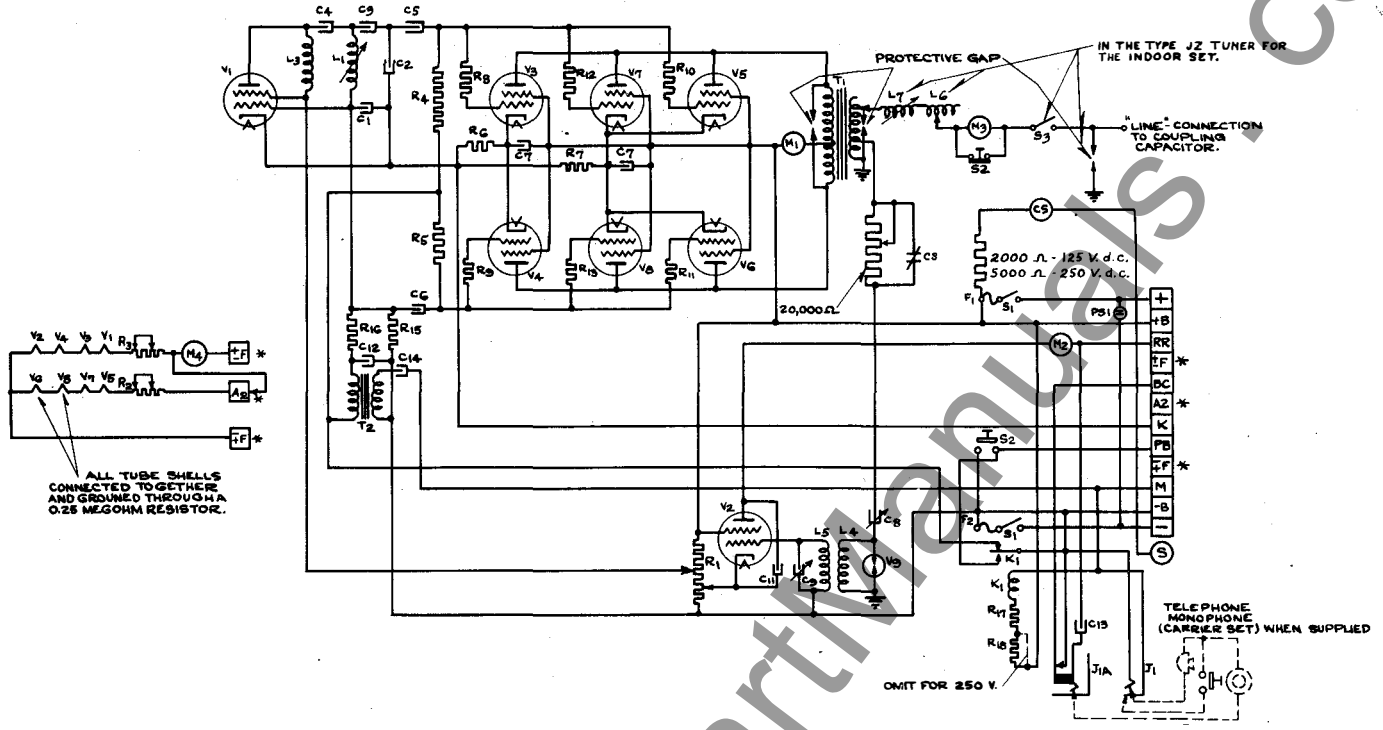

Figure 1
 Internal Connections of the Type G0 Carrier Current
 Transmitter-Receiver with the Sleet Detection Equipment.