



Westinghouse Electric Corporation  
Relay-Instrument Division  
Coral Springs, FL 33065

Application Data  
41-300

Page 1

May, 1981  
Supersedes AD 41-300, Pages 1-32  
dated March, 1977  
Mailed to: E, D, C/2015/DB

## Differential Relays

For Protection of AC  
Generators, Transformers,  
and Station Bus

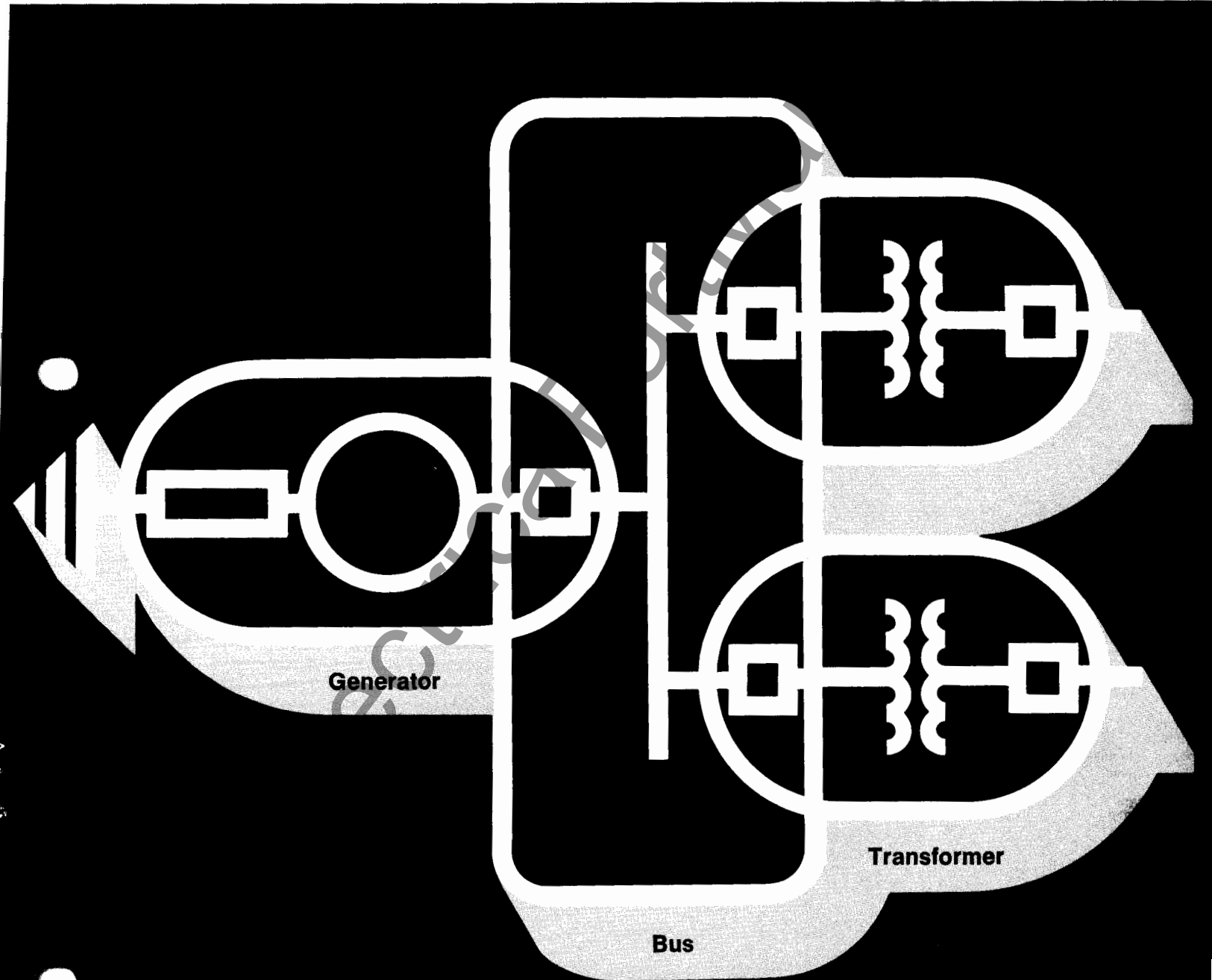

**Table of Contents**

General Application and Selection  
 Principles of Differential Relays . . . . . 2  
 Differential Protection  
   Using Overcurrent Relays . . . . . 3  
 Differential Protection Using  
   Percentage Differential Relays . . . . . 3  
 Differential Protection Using  
   High Impedance Relays . . . . . 4  
 Differential Protection Using  
   Linear Coupler Relays . . . . . 4  
**Generator Differential Relays**  
 Relay Type CA . . . . . 5  
 Relay Type SA-1 . . . . . 7  
**Bus Differential Relays**  
 Relay Type CA-16 . . . . . 9  
 Relay Type HU-4 . . . . . 12  
 Relay Types LC-1, LC-2 . . . . . 14  
 Relay Type KAB . . . . . 18  
**Transformer Differential Relays**  
 Relay Type CA . . . . . 21  
 Relay Type CA-26 . . . . . 23  
 Relay Type HU . . . . . 25  
 Relay Type HU-1 . . . . . 25  
 Relay Type HU-4 . . . . . 25  
 Relay Type HRU . . . . . 31

**Principles of Differential Protection**

**General Information**

Differential relaying systems are universally used for the protection of generators, transformers, station buses, and transmission lines. These differential systems are all based on the principle of balancing or comparing the secondary currents in the current transformers at the terminals of equipment. Due to the distance between terminals of a transmission line, the comparison cannot be made directly, and transmission line relaying therefore is a separate and distinct type of differential relaying. This subject is treated elsewhere.

The basic differential scheme is shown diagrammatically in Figure 1. Under normal load conditions, current flows through the protected equipment (generator, bus or transformer) and the current transformer secondary currents  $I_1$  and  $I_2$  will circulate through path  $I_A$ .

With a protective relay connected between points 1 and 2, no current will flow through the relay under normal conditions. Should a fault occur external to the equipment, current flow will be increased but will be in the same relative direction as under normal conditions, and the relay will not operate for this external fault condition.

When a fault occurs in the protected equipment, the current flow on one side is

reversed, upsetting the normal balance and causing current  $I_D$  to flow through the relay from point 1 to point 2.

As long as the current transformer secondary currents are nearly equal, no appreciable current will flow through the relay operating circuit. Any error current, however, to other phases or to ground, will upset the balance and send current through the relay operating coil. If this current exceeds the pickup setting of the relay, it will operate to trip the breaker and disconnect the faulty apparatus.

Generator differential relays are usually arranged to trip the generator, field circuit, and neutral breakers simultaneously . . . using a manually reset lockout auxiliary relay. In some applications the differential relay also trips the throttle and admits  $CO_2$  to the generator for fire protection.

In transformer differential protection, the high voltage circuit breaker is often located at the remote end of the line serving the transformer. In this application the differential relay initiates a remote trip signal over a pilot wire, tone or carrier channel to the breaker location.

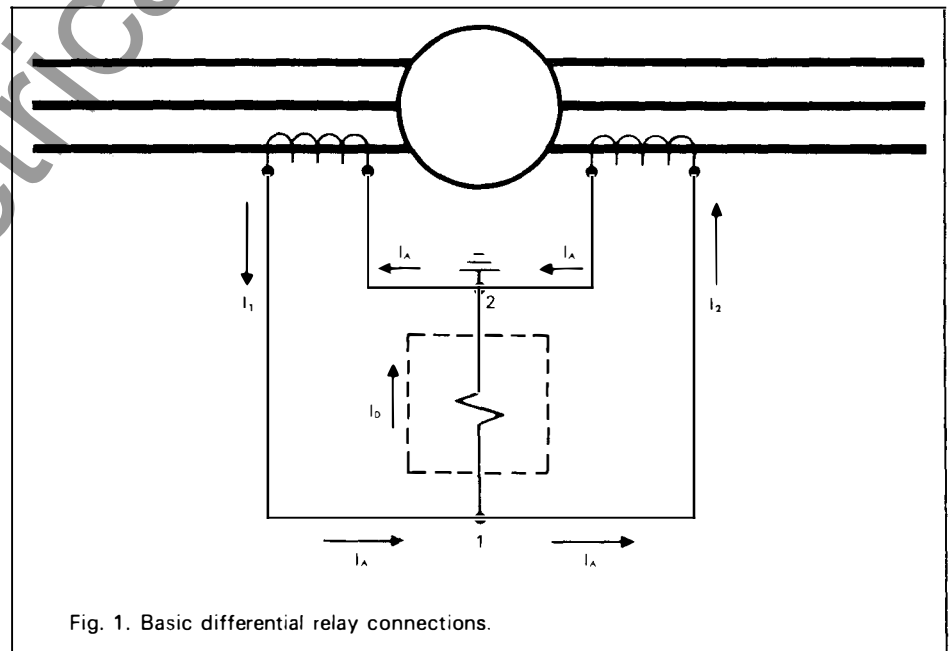

Fig. 1. Basic differential relay connections.



### Differential Protection Using Overcurrent Relays

While standard overcurrent relays have been used in differential schemes (Figures 2 and 3), the rapid increase in the complexity and loading of integrated power systems has created a more selective line of differential relays . . . each with its own operating characteristic.

Sensitive relay settings are required to detect ground faults which may develop into phase-to-phase or three-phase faults. The neutral impedance of a generator limits the magnitude of the ground fault current.

However, relay selectivity requirements may prevent the use of low-current or fast-time settings.

Phase overcurrent protection has definite limitations from the consideration of sensitivity, selectivity, and speed operation, since overcurrent relays must be set above maximum load current and must also have time settings which select with other relays on the system.

The use of restraining windings in differential relay design permits more sensitive relay settings. This affords greater protection than is possible with plain overcurrent relays whose trip settings must be high enough to prevent undesired operation due to current transformer performance under heavy through-fault current.

### Differential Protection Using Percentage Differential Relays

Percentage differential relays have two (or more) additional windings called restraining windings (Figures 4 and 5). The restraining torque is in the contact opening direction and is proportional to the vector sum of the incoming and outgoing currents. On an external fault, this contact-opening torque is strong and tends to prevent false tripping due to the differential current ( $I_D$ ) caused by saturation effects of the current transformers.

On internal faults, most of the current in the restraining windings is in opposite directions so that the total restraint torque is much less than in the case of the external fault.

The relay will trip when the operating torque (created by  $I_D$ ) is greater than the restraining torque, that is, when the operating current is higher than a certain percentage of the smaller or larger of the two restraining currents, depending upon the type of relay to be used.

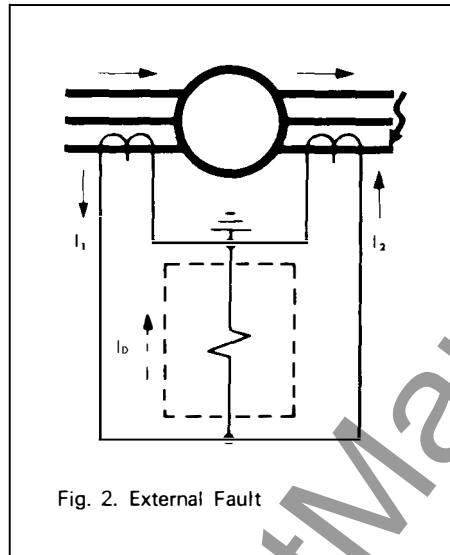

Fig. 2. External Fault

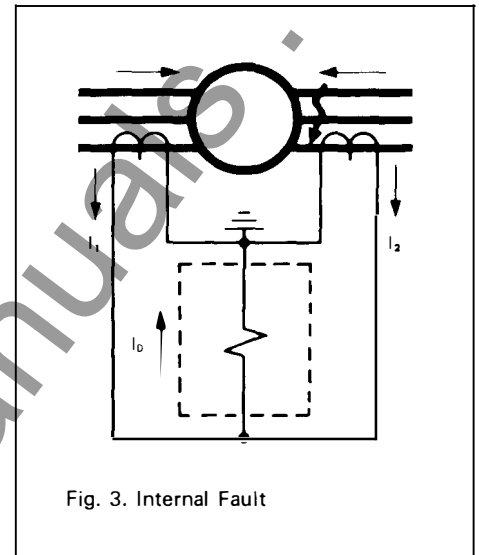

Fig. 3. Internal Fault

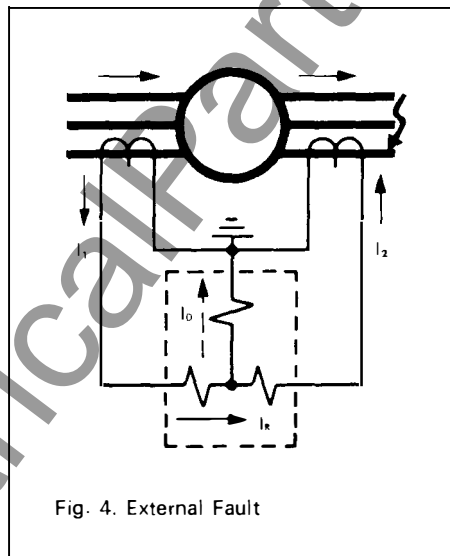

Fig. 4. External Fault

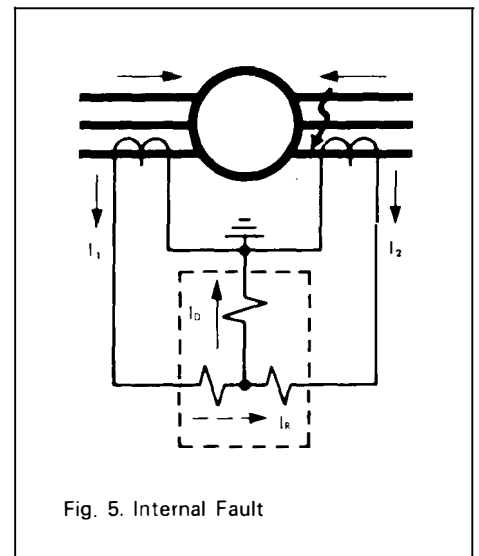

Fig. 5. Internal Fault

Some relays are designed to trip when a constant percentage of unbalance exists between the restraining currents. Other relays operate over a variable range of differential current. These have a "variable percentage" characteristics and as the magnitude of the restraining current increases, a greater amount of operating, or differential current is required to trip the relay.

The variable percentage relay is more sensitive than a constant percentage relay on light internal faults, but less sensitive on heavy external faults; due to the variable percentage characteristic. It is particularly

suitable where heavy saturation currents are encountered.

The burden of the current transformers used in differential relaying schemes is of importance in maintaining the proper relationship between the two sets of current transformers.

The current transformer should not saturate when carrying the maximum external symmetrical fault current (i.e. exciting current should not exceed 1.0 Amp secondary rms. for types SA-1 and CA-16 relays, and 10 Amp for types CA-26 and HU relays, at  $I_F = 100$  Amp). This

requirement is met if the burden impedance does not exceed  $[N_p V_{CL} - (I_{ext.} - 100)R_s] / KI_{ext.}$  Ohms, where:

- $N_p$  = proportion of total number of current transformer turns in use.
- $V_{CL}$  = current transformer accuracy class C (or 10L) voltage.
- $I_{ext.}$  = maximum external fault current in secondary rms. amperes. (Let  $I_{ext.} = 100$  if maximum external fault current is less than 100 Amp).
- $R_s$  = current transformer secondary winding resistance in ohms.
- $k$  = 1.33 for bus protection and 1.0 for transformer protection.

For example, if the 400:5 tap of an 800:5 C400 current transformer is used,  $N_p = 400/800 = 0.5$ , if  $I_{ext.} = 120$  Amp,  $R_s = 1.0$  ohms, the burden should not exceed:

$$\frac{N_p V_{CL} - (I_{ext.} - 100)R_s}{k I_{ext.}} = \frac{0.5 \times 400 - (120 - 100) \times 1.0}{1.33 \times 120} = 1.13 \text{ ohms}$$

for bus or generator protections.

In calculating the impedance burden, a less accurate, but satisfactory method is:

For wye-connected ct:

$$Z_T = 1.13R_L + \text{Relay burden} + Z_A$$

Where  $R_L$  = one way lead resistance in Ohms at 20°C for 3-phase fault condition, and is two way lead resistance in Ohms at 20°C for single phase to ground fault condition.

For delta connected ct:

$$Z_T = 3(1.13R_L + \text{Relay burden} + Z_A)$$

Where  $R_L$  = one way lead resistance in Ohms at 20°C

Note that the 1.13 multiplier is used to account for temperature rise to 60°C during faults.

$Z_A$  = an additional burden, if any.

When using the type SA-1 relay for generator differential protection the current transformer sets may have different accuracy classes. If so, their burden factor, BF, should not differ by more than a 2 to 1 ratio. The burden factor is defined as:

$$BF = \frac{1000 R_B}{N_p V_{CL}}$$

where  $R_B$  = resistance of the burden excluding current transformers winding resistance.

For example: Assuming the above set of current transformers has a resistance burden of  $R_B = 0.5$  ohms, the burden factor is:

$$BF = \frac{1000 R_B}{N_p V_{CL}} = \frac{1000 \times 0.5}{0.67 \times 200} = 3.8$$

The other set of current transformers may then have a burden factor as high as  $2 \times 3.8 = 7.6$ , or as low as  $\frac{1}{2} \times 3.8 = 1.9$ . If the other set of current transformers also has a burden of 0.5 ohms, a C100, C200 or C400 (or 10L100, 10L200 or 10L400) rating would be satisfactory since the burden factors are 7.6, 3.8 and 1.9 respectively.

#### Differential Protection Using High Impedance Relay

While the high impedance differential scheme also uses conventional current transformers, it avoids the problem of unequal current transformer performance by loading them with a high-impedance relay unit. All current transformers are connected in parallel then connected to a high impedance relay unit (Fig. 6). In normal operation the voltage at the relay terminals is approximately zero. In the case of an external fault, the voltage at the relay terminals still remain approximately zero if both the source current transformers and the faulted current transformer are not saturated. However, during severe external faults, the faulted current transformer may saturate and no voltage or current can be developed from its secondary winding. The source current transformers would then have to force their current flow into the faulted current transformer and the relay. The impedance in the relay is much higher than that in the faulted current transformer when it is saturated, therefore, most of this external fault current flows into the faulted current transformer, preventing the relay from operation due to the saturation of the faulted current transformer.

In the case of internal faults, all impedances of the current transformers and the relay are high, this makes a high impedance burden to the current transformers. A high voltage will appear at the relay terminals and will be well above the pickup setting. The relay will operate.

This type of protection is particularly applicable to the protection of station buses where the dc component of short circuit current has a long time constant and causes saturation in current transformers.

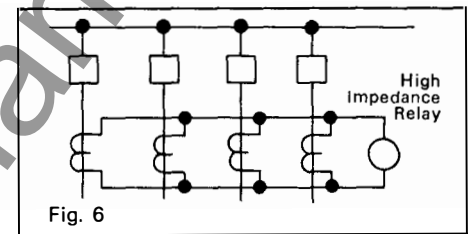

Fig. 6

#### Differential Protection Using Linear Coupler Relays

Linear coupler transformers produce secondary voltages proportional to the applied primary currents.

The linear coupler method of differential protection is essentially a voltage differential scheme and, consequently, a series circuit is used in contrast to the parallel circuit employed with current transformer schemes. In the case of an external fault as shown in Figure 7, the sum of the voltage induced in the linear coupler is zero.  $E_1 + E_2 - E_N = 0$ .

This occurs because the sum of the currents flowing to the bus is equal to the sum of the currents flowing out to the system . . . and the relay does not trip. In the case of an internal fault, see Figure 8, the above voltage cancellation does not exist, and the difference voltage appears at the terminals of high speed, low energy, linear coupler relay which trips instantaneously. The linear couplers are in effect air core mutual reactors. They are similar to current transformers in general appearance and structural detail except they have an air core with a permeability of 1.0; thus will not saturate or cause error currents even when heavy primary currents exist.

This type of protection is particularly applicable to the protection of station buses where the dc component of short circuit current has a long time constant and causes saturation in current transformers of conventional design.

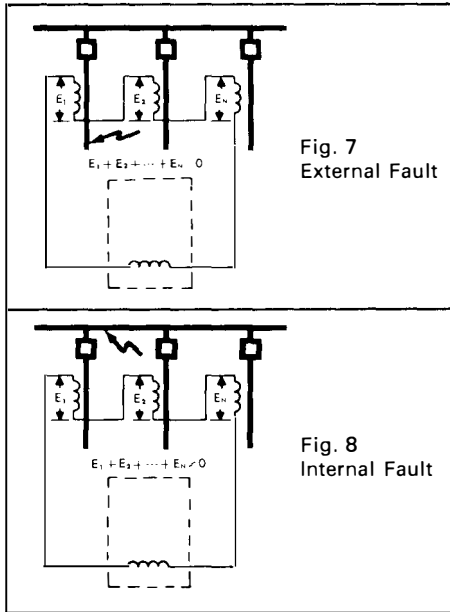

**Type CA Single Phase, Inverse Timing, Constant Percentage**

The basic connections for this relay are shown in Figure 9.

Connected as shown, under normal conditions current passes through the current transformers, relay restraining coils  $R_1$  and  $R_2$  and back to the current transformers. The current in the relay restraining coils produces a restraining, or contact opening torque.

An internal fault in the protected machine will unbalance the secondary currents, forcing a differential current  $I_D$  through the relay operating coil  $O$ . The amount of differential or operating current required to overcome the restraining torque and close the relay contacts is a fixed (constant) percentage of the smaller restraining current (Figure 10).

- Characteristics**  
Single phase, 25 to 60 Hertz, spst-cc or dpst-cc contacts, FT-21 Flexitest case, inverse time characteristic
- Operating time: See Figures 12 and 13
- Two restraining and one operating circuit
- No ratio taps
- Constant percentage differential
- Sensitivity: 10% or 25% unbalance

**Generator Differential Relays**  
The relays described in this section are percentage differential types. The magnitude of the differential current required to operate them increases as the external fault (or through) current increases.  
  
In the type CA inverse timing relay the percentage is constant, and in the type SA-1 instantaneous 3-phase relay the percentage is variable.  
  
These relays are extremely sensitive, yet they will not trip on a through fault unless the difference current expressed as a percent of the smaller restraint current exceeds the percent sensitivity of the relay.

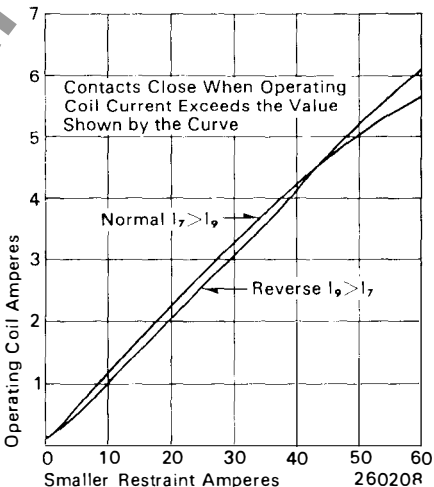
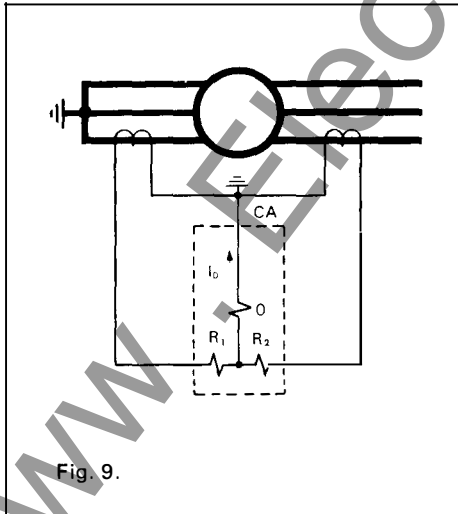

Fig. 10. Typical operating curves, 10% CA relay.

- Minimum trip  
0.18 amperes for 10% relay  
0.45 amperes for 25% relay
- Burden: See Figures 15 and 16
- Thermal capacity  
Restraint Circuits: 10 amperes continuous  
Operating circuits: 10% relay, 2.5 amperes continuous, 70 amperes for 1 second; 25% relay, 5.0 amperes continuous, 140 amperes for 1 second

**Relay Settings**  
No setting is required for the percentage differential unit except the setting of the time dial, which should be on the number 1 position.

Each relay is designed for a specific sensitivity and once the correct relay is chosen for a given application, no adjustment is necessary. If, for some reason, adjustment becomes necessary, the spring tension controlling minimum operating current may be altered slightly.

In general, for generator protection, a study of the current transformer characteristic curves under short circuit conditions should indicate whether the high sensitivity (10%) or the low sensitivity (25%) relay should be used. The 25% relay should be used if ac saturation causes more than 1% ratio error in either set of current transformers.

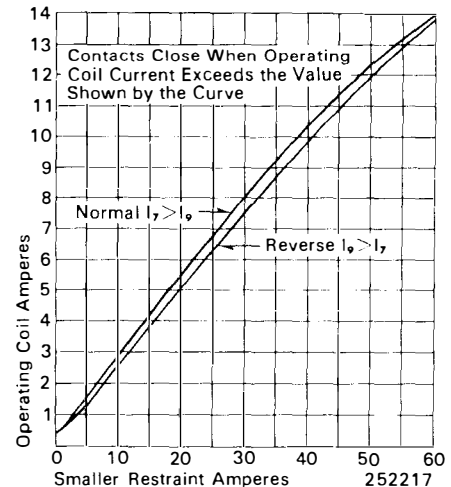

Fig. 11. Typical operating curves, 25% CA relay.

Type CA Single Phase, Inverse Timing, Constant Percentage

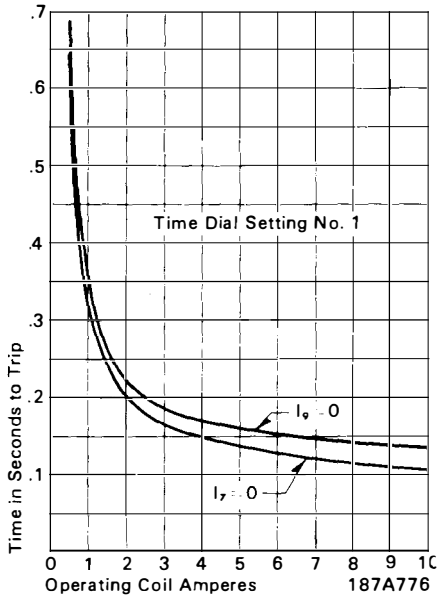

Fig. 12. Typical time curves, 10% CA relay.

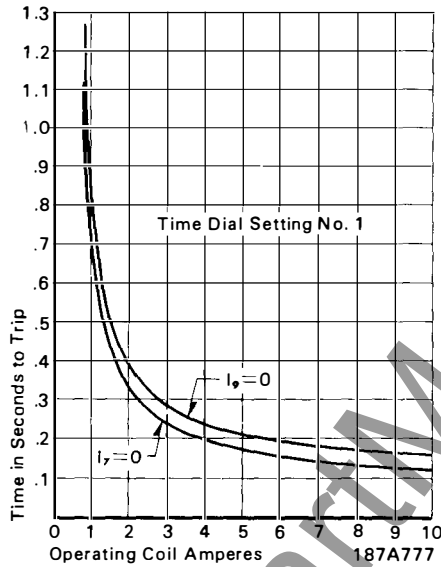

Fig. 13. Typical time curves, 25% CA relay.

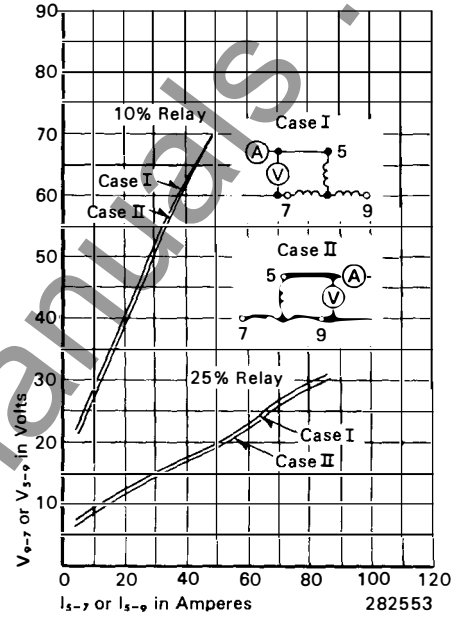

Fig. 14. Typical saturation curves, all CA relays.

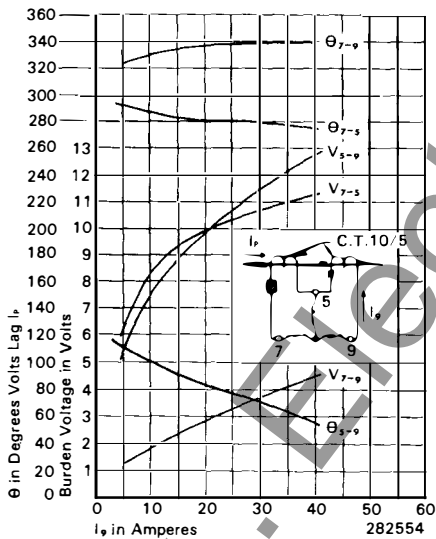

Fig. 15. Typical burden curves, 10% CA relay.

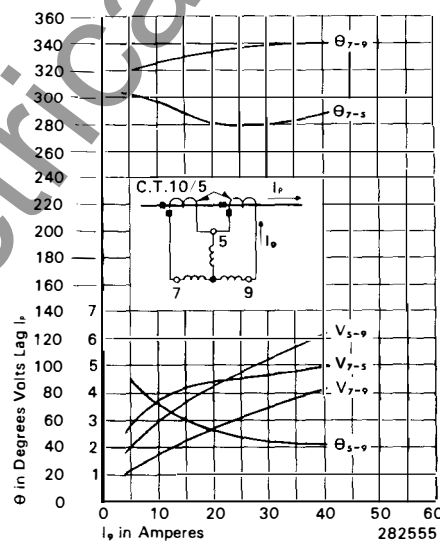

Fig. 16. Typical burden curves, 25% CA relay.

**Further Description**  
Descriptive Bulletin 41-331  
Instruction Leaflet 41-331.2



**Type SA-1 Solid State, Three-Phase, Instantaneous, Variable Percentage**

The SA-1 solid state relay is used for 3-phase, high-speed type differential protection of ac motors, generators, and shunt reactors. The variable percentage characteristic of the relay provides high sensitivity for light, internal faults, and avoids incorrect tripping on heavy external faults. See Figures 17, 18.

The standard SA-1 relay has a minimum pick-up current of 0.14 amperes. It operates at 5% unbalance (.25 amperes) with 5 amperes of restraint current. At 60 amps restraint, the operating circuit required to trip the relay is 30 amperes or 50% unbalance.

With proper selection of current transformers, the relay is unaffected by dc transients associated with asymmetrical faults through short circuit conditions.

For special cases, such as a split-winding generator protection the 0.5 amp minimum pick-up relay should be used.

**Further Description**  
Descriptive Bulletin 41-348  
Instruction Leaflet 4-348.1

**Characteristics**

Three-phase, 60 Hz, 5 amperes  
Percentage slope curve: Figures 17, 18  
Operating time: Figure 19.  
Frequency response: Figure 20.  
Minimum pick-up: 0.14 amperes. (0.5 ampere relay for special applications).

**Burden and thermal ratings**

Each restraint circuit:  
Burden: 0.25 volt-amperes at 5 amperes.  
Continuous rating: 20 amperes.  
One-second rating: 300 amperes.

**Operating circuit:**

Burden of the operating circuit on each current transformer is variable because of the saturating transformer.  
Burden is 0.37 volt-amperes at 0.5 amperes, and 170 volt-amperes at 60 amperes.  
Continuous rating is 10 amperes.  
One-second rating is 200 amperes.  
dc burden on station battery is:

Volts	Milliamperes	Watts
48 dc	60	2.9
125 dc	55	6.9

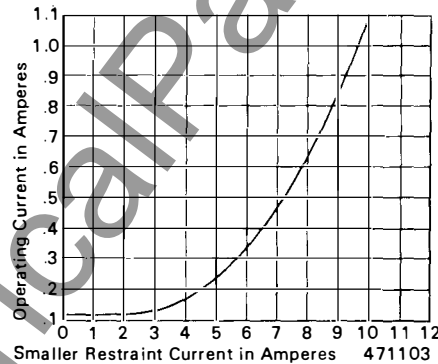

Fig. 17. Percentage slope characteristic at low values of restraint current.

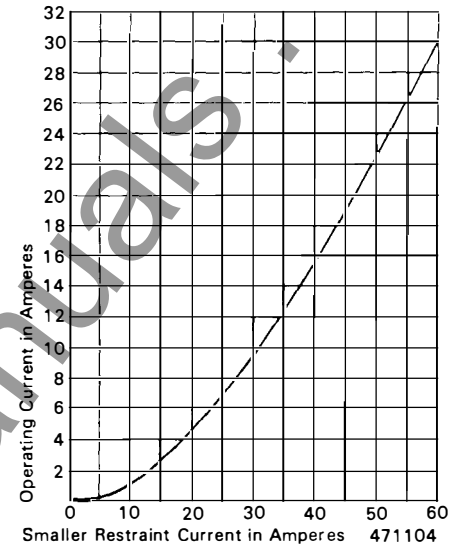

Fig. 18. Percentage slope characteristic at large values of restraint current.

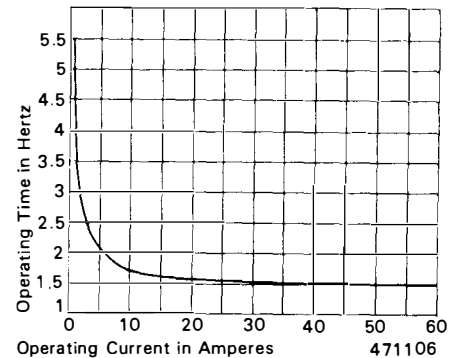

Fig. 19. Typical operation time characteristic curve.

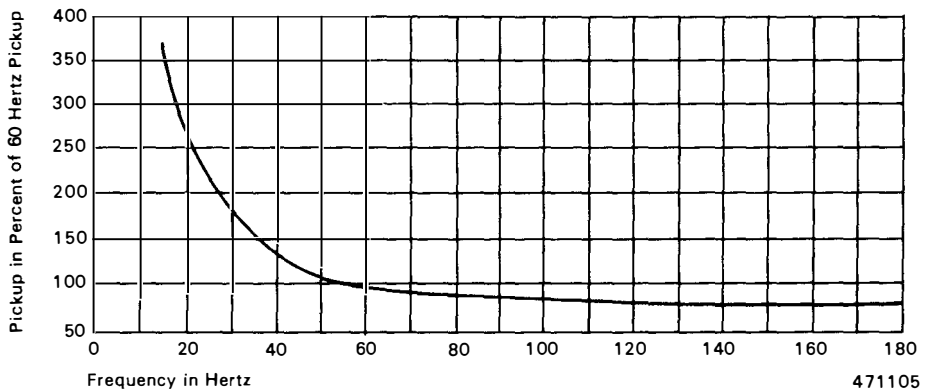
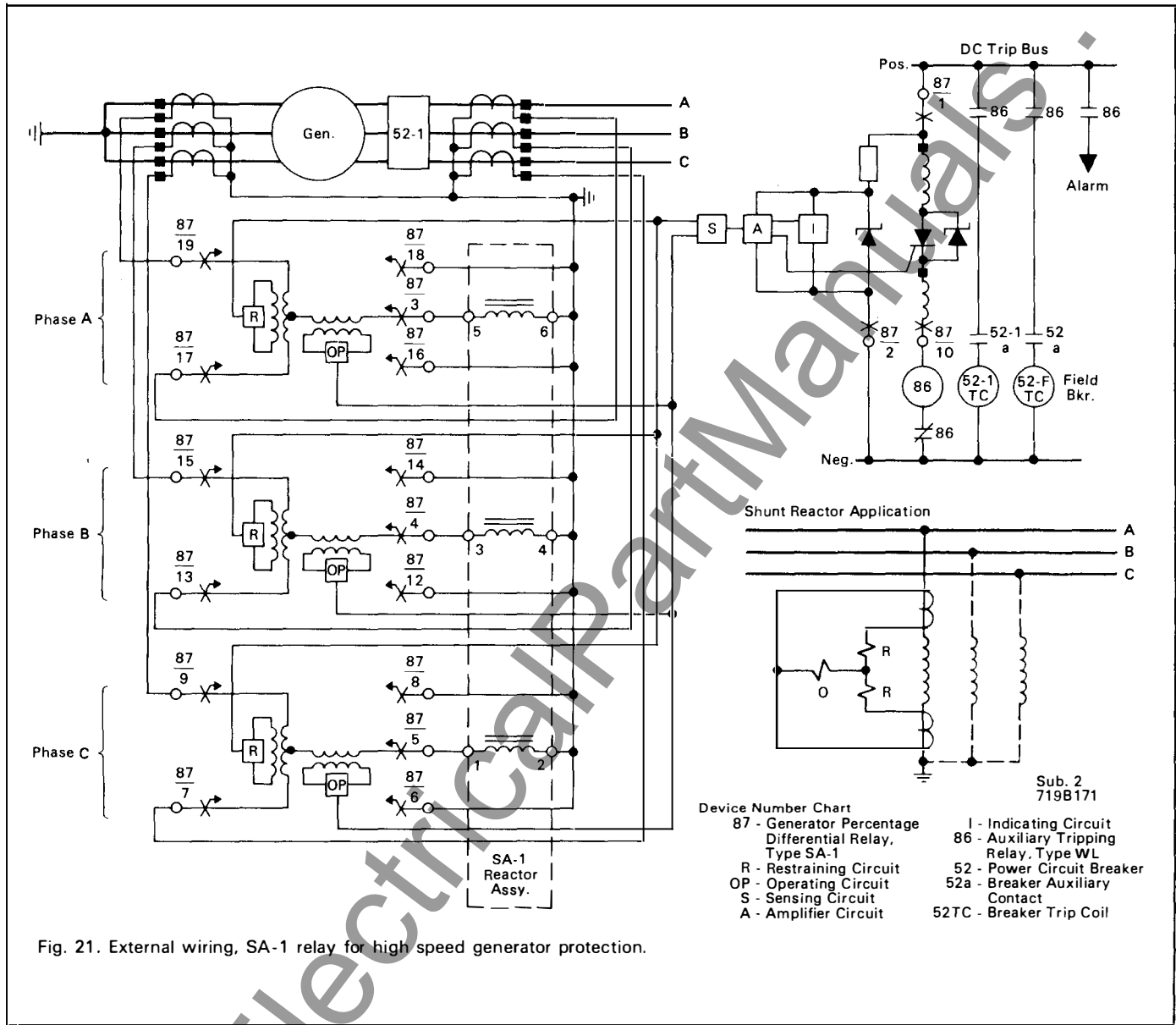

Fig. 20. Typical frequency response curve.





**Bus Differential Relays**

In generating stations and sub-stations there are usually several incoming and outgoing lines connected to the bus; all of which must be included in the bus differential protection zone.

For low impedance relays, the differential scheme must provide a restraining circuit for each circuit that is connected to the bus, so that there will be no response to external faults under any system condition and with the faulted current transformer saturated.

In addition, the relay should be sensitive at low current values to operate on a light internal fault, yet relatively insensitive at high values of current to prevent tripping on heavy external faults when the current transformer characteristics might vary.

For high impedance relays, the arrangement tends to force the false-differential currents through the faulted current transformer rather than through the relay operating coil when the faulted current transformer is saturated.

The linear coupler system, uses a series connection between all the linear couplers in the protected zone with a simple low energy high speed relay. This system is described more fully on pages 14 through 19.

**Type CA-16 Single Phase, Inverse Timing, Variable Percentage**

The CA-16 is designed for the differential protection of multi-circuit buses up to a total of six groups of circuits. The variable percentage characteristic provides the desirable high sensitivity at small current magnitudes and relative insensitivity at high currents. It will therefore detect light internal faults in the protected bus section and, conversely, will not trip incorrectly on heavy external faults.

The optional sensitive fault detector circuit consists of an autotransformer and a small solenoid type contactor switch, is used to minimize the possibility of shock tripping.

**Characteristics**

Single phase, 60 or 50 Hertz, spst-cc or dpst-cc contacts, FT-32 Flexitest case

Operating time: see Figure 24  
 Six restraint circuits, one operating circuit  
 No ratio taps

Variable percentage characteristics: see Figures 22 and 23

Minimum trip: 0.15 amperes

Burden:  
 Each restraint circuit:  
 0.75 volt-amperes at 5 amperes  
 14 amperes continuous rating  
 460 amperes 1 second rating  
 Operating circuit: burden, see Figure 25  
 8 amperes continuous rating  
 280 amperes 1 second rating

Relay settings: none required  
 Performance curves: see Figures 22 to 25

**Further Information**

Descriptive Bulletin 41-337  
 Instruction Leaflet 41-337.3



Fig. 22. Variable percentage slope curve, CA-16 relay with one restraint winding.

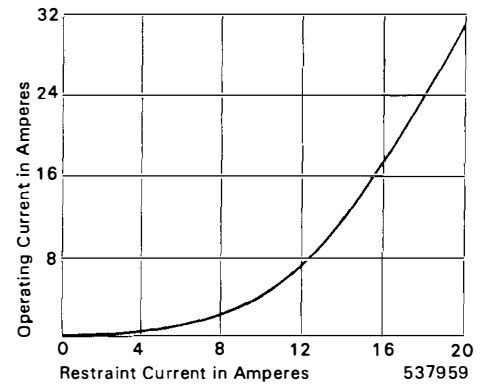

Fig. 23. Variable percentage slope curve, CA-16 relay with six restraint windings in series.

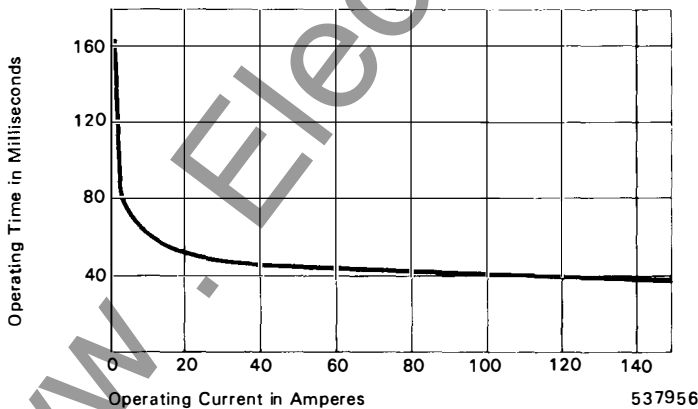

Fig. 24. CA-16 relay typical time curve.

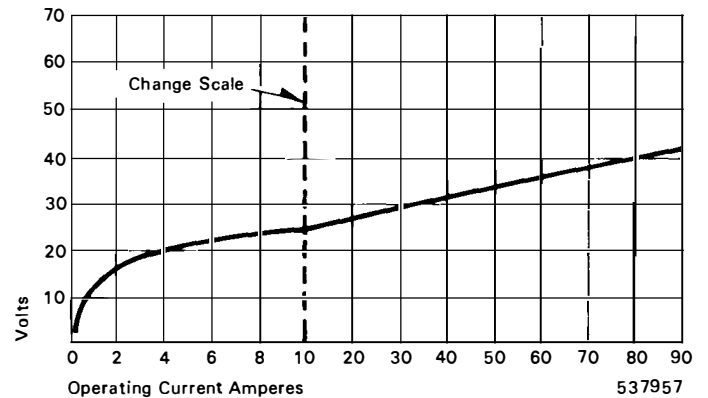

Fig. 25. CA-16 relay typical burden operating curve.

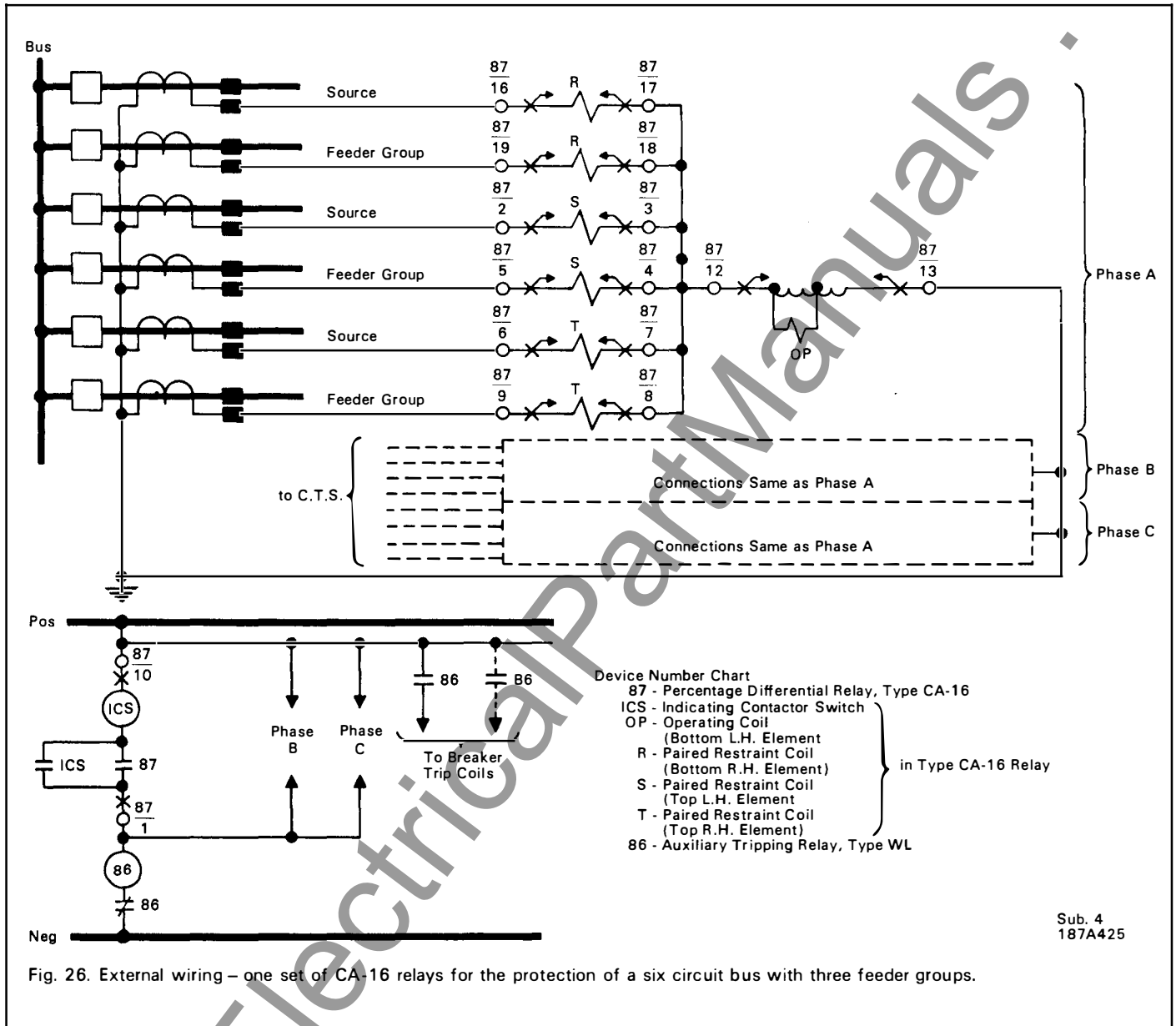

Fig. 26. External wiring – one set of CA-16 relays for the protection of a six circuit bus with three feeder groups.



**Type HU-4 Single Phase, Instantaneous, Variable Percentage**

This relay is a high speed unit with four restraint circuits and one operating circuit. In addition, it has a second harmonic restraint unit for use where a transformer is associated with the bus differential scheme. The harmonic restraint provides security against false tripping on magnetizing inrush associated with the transformer energization.

The variable percentage characteristic provides high sensitivity at high currents. It will therefore detect light internal faults and will not trip incorrectly on heavy external faults.

The type HU-4 may be applied to any bus circuit where the external fault current through the bus is twenty times tap value secondary current or less, i.e. 100 amperes on 5 ampere tap.

External connections, as shown in Figure 31, with the relay input limited to four restraint circuits including transformer circuit.

**Characteristics**

Single phase, 60 or 50 hertz, dpst-cc contacts, FT-42 Flexitest case

Operating time: see Figure 29.  
 Four restraint circuits, one second harmonic restraining circuit, and one operating circuit.

Ratio taps: 2.9, 3.2, 3.5, 3.8, 4.2, 5.0, 8.7 ampere taps on each restraint circuit.

Variable percentage characteristics: see Figure 28.

Minimum trip: 30% or 35% of tap value IIT is adjusted for an RMS operating current (with the second harmonic component removed) pick-up of 15 times tap value current (e.g. 75 amperes on 5 amperes tap).

Relay settings: Same as those for types HU and HU-1 relays, pages 25 to 29. (HU-4 is similar to HU and HU-1, except that it has four restraint circuits.)

Performance curves: see Figures 28 to 30.  
 Thermal rating: one second—300 amperes.

(Thermal capacities for short times other than one second may be calculated on the basis of time being inversely proportional to the square of the current.)

**Further Information**

Descriptive Bulletin 41-347  
 Instruction Leaflet 41-347.1

**Burden Data:**

Tap	Con- tinuous Rating	Power Factor Angle①	At Tap Value Current	Volt-Amperes@	
				At 8 Times Tap Value Current	At 20 Times Tap Value Current
<b>Burden of Each Restraint Circuit</b>					
2.9	10	.71	.88	50	191
3.2	12	.70	.89	51	211
3.5	13	.66	.90	51	203
3.8	14	.65	.91	53	220
4.2	15	.58	.91	53	235
4.6	16	.57.5	.91	55	248
5.0	18	.52.5	.92	59	280
8.7	22	30	1.28	94	340

Tap	Con- tinuous Rating	Power Factor Angle①	At Tap Value Current	Volt-Amperes@	
				At 8 Times Tap Value Current	At 20 Times Tap Value Current
<b>Burden of Operating Current</b>					
2.9	10	.35	2.26	76	487
3.2	12	.34	2.30	78	499
3.5	13	.33	2.30	81	504
3.8	14	.33	2.30	83	547
4.2	15	.31	2.30	84	554
4.6	16	.30	2.40	88	598
5.0	18	.29	2.50	92	640
8.7	22	.23	3.18	132	850

\* Degrees current lags voltage at tap value current.  
 @ Voltages taken with Rectox type voltmeter.

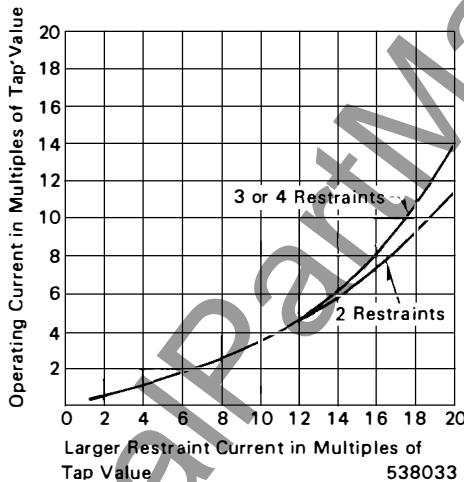

Fig. 28. Variable percentage slope curve, HU-4 relay.

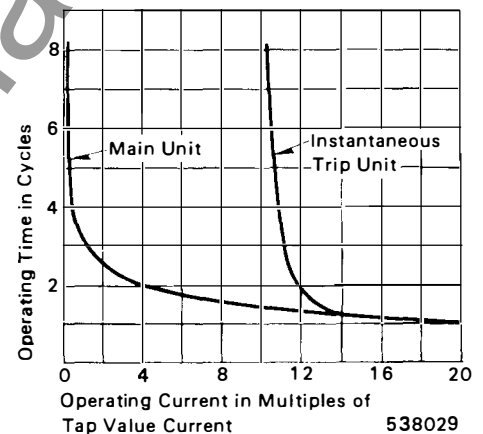

Fig. 29. Typical time curve, HU-4 relay.

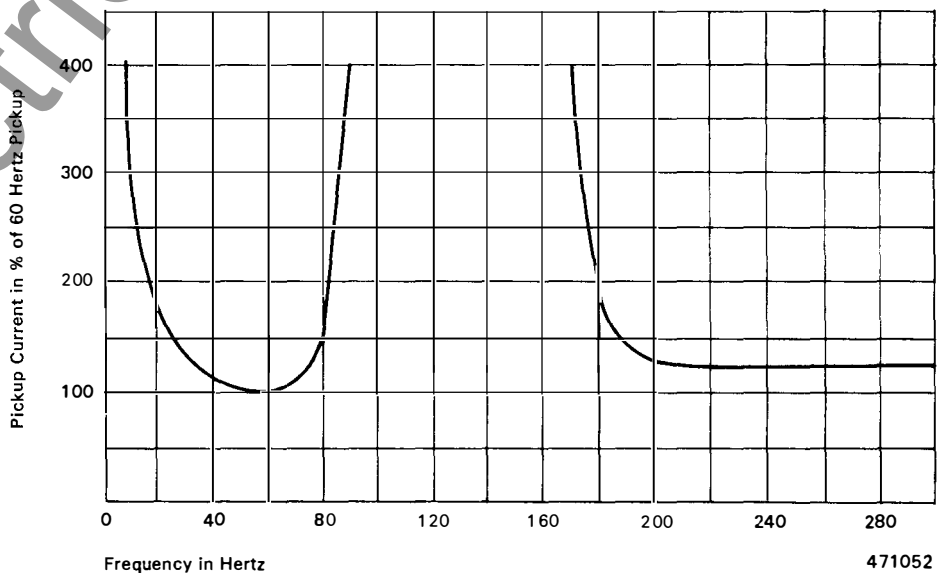

Fig. 30. Frequency response curve, HU-4 relay.

com

www.electricalmanuals.com

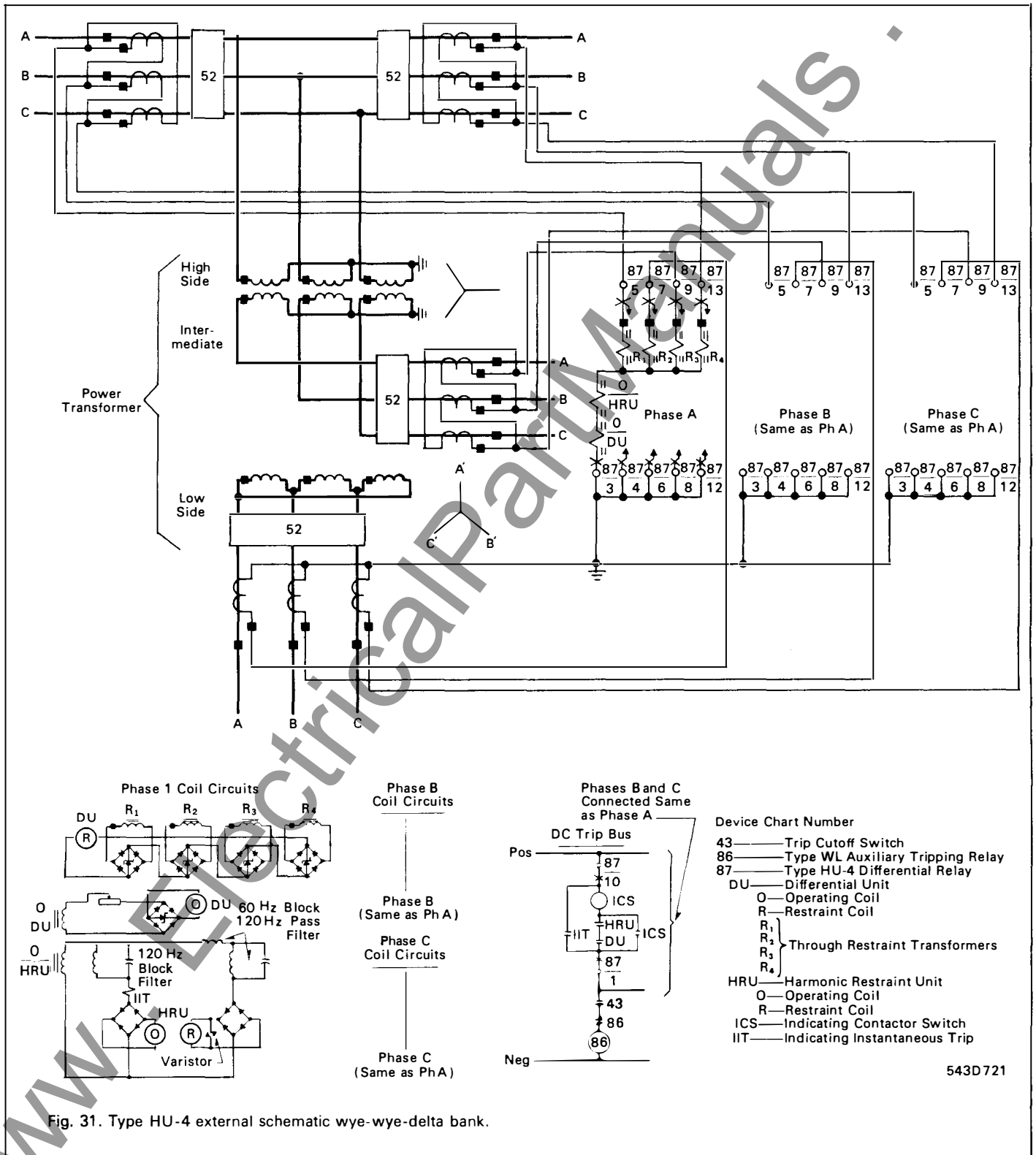

Fig. 31. Type HU-4 external schematic wye-wye-delta bank.

**Type LC-1, LC-2 Single Phase, Instantaneous, Linear Coupler**

The linear coupler method of bus protection utilizes air core mutual reactors known as linear couplers, instead of the usual current transformers. It employs the voltage output of the couplers in a series voltage differential circuit. The energy output of the couplers makes possible the use of low-energy, high speed relays, types LC-1 and LC-2. Each is provided with impedance taps so that the impedance of the relay can be more closely matched to the impedance of the linear couplers when such is required for maximum sensitivity.

When the relay and coupler impedances are matched, there is a maximum amount of operating energy transferred from the coupler to the relay. Since the standard linear coupler induces 5 volts secondary per 1000 amperes primary, the couplers (unlike current transformers) can be safely open-circuited. Danger to personnel from high voltages is eliminated.

It is well to bear the following in mind when using linear couplers for bus differential applications:

- (1) Bushing space must be allocated to the linear coupler, rather than a current transformer which is more universal in use.
- (2) The linear coupler has a low wattage output.
- (3) The leads must be in the same duct or conduit and transposed with respect to all other circuits.

**Relays Used**

Type LC-1: Consists primarily of an impedance matching transformer and solenoid unit which has trip contacts. It covers four taps of 30, 40, 60 and 80 ohms and is adjustable to operate at energy levels rated from 0.5 to 8.0 volt-amperes.

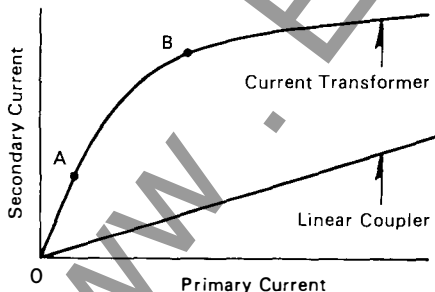

Fig. 32. Current transformers and linear coupler saturation curve.

Type LC-2: The use of a dc operating polar unit energized by a rectifier from the saturating impedance-matching transformer makes the LC-2 more sensitive than the LC-1. It covers four taps of 30, 40, 60 and 80 ohms and is adjustable to operate at energy levels rated from 0.0085 to 0.062 volt-amperes.

The auxiliary switch  $V_s$  is a small dc voltage operating clapper type switch used to minimize the possibility of shock tripping.

**Current Transformers and Linear Couplers**

In differential protective schemes, the relays and current transformers function as a team. The current transformers must interpret, in their secondary windings, the ac current conditions existing in the power circuit . . . and transmit this information to the relays. The typical saturation curve shown below (Figure 32) indicates that secondary currents are proportional to primary currents along the curve portion OA of the curve corresponding to the nominal rating of the transformer. When large short circuit currents occur, the secondary current of the heavily saturated current transformer is indicated on the upper portion of the curve, portion AB, and the ratio of transformation is rarely equal for two different types of current transformers. It is necessary to know the magnitude of the error-current, so that relays and their settings can be chosen to compensate for the current transformer errors.

**Saturation from ac Component of Fault Current**

Ac saturation is not particularly troublesome since it can be calculated, and compensation made for the resulting errors in secondary current. For a given current, saturation results from: (a) insufficient cross section of iron in the transformer core, (b) too few secondary turns, (c) too high a secondary burden; or a combination



Fig. 33. Typical bushing type linear coupler.

of all three. The degree of saturation due to the maximum ac current can be calculated from the formula:

$$B = \frac{I Z_s 10^8}{4.44 n f a}$$

when:

B = Flux density in the core in lines per square inch.

I = Maximum secondary short-circuit current in RMS amps.

$Z_s$  = Total secondary circuit impedance including current transformer secondary in ohms.

n = Number of secondary turns.

f = Frequency.

a = Iron cross-section in square inches.

a = Iron cross-section in square inches

Thus, for a given short-circuit current and a given transformer, both decreasing the secondary impedance and increasing the secondary turns will improve the performance of the transformer by requiring a lower flux density to supply the burden. It is therefore recommended that the highest rated available current transformer ratios be used, consistent with the requirement that the minimum internal fault can be safely tripped. If some saturation results, it may be possible to raise the relay setting to provide a sufficient margin of safety. The minimum trip requirement must not be exceeded, however.

**Saturation From dc Component of Fault Current**

If the fault current is asymmetrical, a dc component is present. When it decays slowly because of long dc time constant (large L/R ratio), transient saturation of the

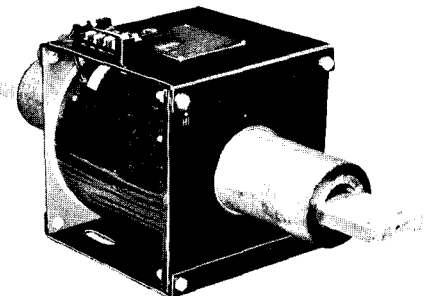

Fig. 34. Typical bar type linear coupler.



current transformer results. This condition occurs more frequently in the protection of generating station buses when the dc time constant of the circuit is apt to be long. For most substation buses, the time constant is short and no appreciable effect from dc saturation results.

The presence of a prolonged dc component will produce a severe transient saturation. Even though it would be technically possible to design a current transformer that would not saturate, calculations show that such current transformers would require a cross section of iron as much as one hundred times larger than current transformers of standard construction.

#### Linear Coupler Scheme

The problems associated with the saturation of the core of current transformers are eliminated when linear couplers are used.

The linear coupler consists of a toroidal or ring type secondary winding on a non-magnetic core. It is usually mounted in a circuit breaker or transformer bushing and can be designed to fit into the space available for a conventional current transformer. See Figures 33 and 34.

The single conductor in the bushing forms the primary of the linear coupler reactor and, because of the absence of iron, avoids problems due to saturation and provides a definite linear relationship between primary currents and secondary voltage. The system employs a series circuit in contrast to the parallel circuit used with current transformers. All of the linear coupler secondaries of a particular phase are connected in series with one type LC relay to form a closed loop. Under normal conditions, or when external faults occur, the induced voltages in all the linear couplers are cancelled out. On internal faults, a net voltage is available for relay operation. The scheme is fast in operation, simple, and easily checked while in service.

The ratio between maximum external fault current and minimum internal fault current is limited to 25/1 (except when a separate ground LC relay is used), not because of the relay, but because of the economic manufacturing tolerances of the couplers. Couplers are made to plus or minus 1-percent accuracy. The possibility exists that one coupler may be +1% and another in the same circuit -1%, with maximum current flow. This gives a 2-percent accuracy spread which, combined with a 2/1 safety factor, limits the relay pickup to not less than 4-percent of the maximum through fault current of a ratio of 1/25 between minimum internal and maximum external fault currents.

The external fault usually will be a solid three phase fault while the internal fault usually is a line-to-ground fault.

Example: Assuming a 5000-ampere maximum external fault current, the LC relay should not be set to pick up on less than 4-percent of 5000 or 200 amperes primary current. Therefore, 200 amperes primary current is the minimum internal fault the relay can be set to detect.

The calculations for settings and performance involve a simple application of Ohm's Law.

#### Selection of LC-1 or LC-2

The anticipated relay current is calculated by the following formula:

$$I_{\text{relay}} = \frac{I_{\text{ext}} \times Z_M}{25 \times 2 \times Z_C \times N}$$

This gives the approximate value

$I_{\text{ext}}$  = Maximum external primary fault current in amps.

$Z_M$  = 5 volts/1000 amps = Mutual impedance of one coupler.

25 = 25/1, which is ratio of maximum external to minimum internal fault current. Includes coupler tolerance and safety factor details.

2 = Reduction factor: If coupler series impedance ( $Z_C$ ) is 60 ohms, then double (2) this value because the relay would be set on the 60 ohm tap and adds 60 ohms additional impedance to relay circuit.

$Z_C$  = Impedance of one coupler—average of 10 ohms each.

$N$  = Number of series couplers in one phase.

For Relay Currents:	Use Relay Type
10- 50 mA	LC-2
50-200 mA	LC-2 plus ext. parallel resistor <sup>ⓐ</sup>
200-400 mA	LC-1

<sup>ⓐ</sup> The external fixed resistor assembly 19 ohms, used with the LC-2 relay reduces the relay current ( $I_r$ ) to a value within the recommended operating range of the relay. In setting the LC-2, the resistor is used for coarse adjustment, and the flux shunts on the polar unit are used for more exact calibration.

#### Required Information

Maximum external fault current: phase and ground.

Minimum internal fault current: phase and ground.

Number of couplers per phase.

Coupler impedance (estimate at 10 ohms if unknown)

#### Characteristics

##### LC-1 Relay

Single phase, 60 or 50 hertz, spst-cc contacts, FT-11 Flexitest case.

Operating time: 1 cycle or less above 150% of pickup.

Impedance matching taps: 30, 40, 60, 80 ohms.

Sensitivity: 0.5 volt-amperes.

##### LC-2 Relay

Single phase, 60 or 50 hertz, spst-cc contacts, FT-11 Flexitest case.

Operating time: 1¼ to 1¾ cycles including time for VS contactor.

Impedance matching taps: 30, 40, 60, 80 ohms.

Sensitivity: Adjustable .0085 to .062 volt-amperes.

#### LC-1 and LC-2 Settings

The following fundamental equations apply:

$$E = I_p M \quad (1)$$

$$I_r = \frac{E}{Z_s} \quad (2)$$

$$I_r = \frac{I_p M}{Z_s} = \frac{I_p M}{N Z_c + Z_r} \quad (3)$$

$$I_p = \frac{I_r Z_s}{M} = \frac{I_r (N Z_c + Z_r)}{M} \quad (4)$$

where:

$E$  = voltage induced in linear coupler secondary.

$I_p$  = primary current in linear coupler.

$M$  = mutual impedance of linear coupler = .005 ohm for 60 hertz.

$I_r$  = relay current.

$Z_s$  = impedance of secondary circuit.

$N$  = number of secondary circuit = number of linear coupler secondaries in series per phase.

$Z_c$  = self-impedance of linear coupler secondary.

$Z_r$  = relay impedance.

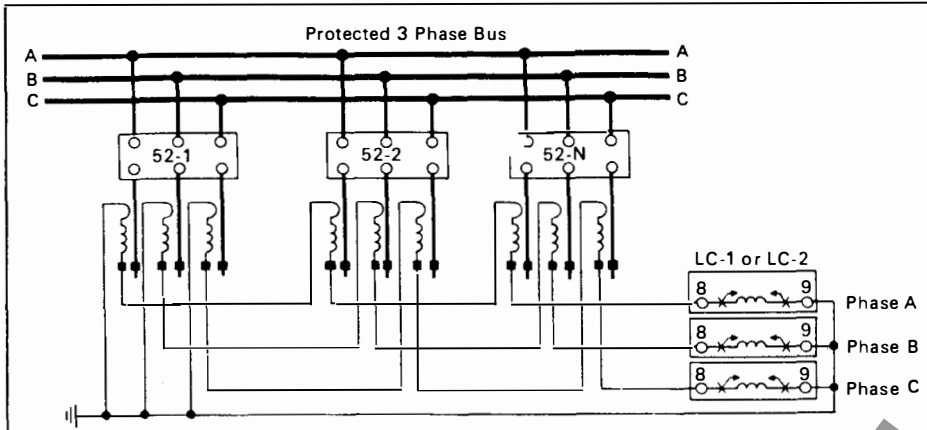

Fig. 35. External wiring, LC-1 and LC-2 relays.

Sub. 2  
 182A822

Equation (3) is used to determine the current at which the relay trips for an internal fault of magnitude  $I_p$  on the bus. Equation (4) is used to determine the primary current necessary to trip the relay when it has been adjusted to trip at a known value of relay current.

It should be noted, however, that the relay impedance is not constant, but varies with relay current as indicated in Figures 38 and 40. Therefore, in using equation (3) it is desirable to assume a value of relay impedance equal to the impedance tap and make a first calculation of the relay current. When this is obtained, a new value of relay impedance should be selected from Figure 38 or 40 and a second value of relay current calculated. Usually, it will not be necessary to continue the calculation any further, as the values resulting from the second calculation will be sufficiently accurate.

**LC-1 Setting Example**

Assume a six circuit bus for which the linear couplers have a self-impedance of

$$Z_c = 3.7 + j8.9 = 9.64/67.4^\circ. \text{ Three type}$$

LC-1 relays are used, one per phase, to obtain phase and ground fault protection. The maximum external fault current is 60,000 amperes rms symmetrical. It is desired to set the relays to trip on a minimum internal fault of 5000 amperes. However, since the linear couplers and relays will operate over a 25/1 range to 2 to 1 factor of safety, the relays may as well be set for 2400 amperes, which is 1/25 of 60,000.

The self impedance of the linear coupler secondaries is determined first, as follows:

$$NZ_c = 6(3.7 + j8.9) = 22.2 + j53.4 = 57.8/67.4^\circ.$$

For any given primary current, the relay receives maximum energy when the impedance  $Z_r$  is made equal to  $NZ_c$ . This feature is utilized by matching  $Z_r$  and  $NZ_c$  as closely as possible in those cases where it is desirable to obtain the lowest possible minimum tripping current. In other cases, the relay impedance  $Z_r$  and the total linear coupler self impedance  $NZ_c$  may be deliberately mismatched in order to extend the range of adjustment to a higher current value. In this example, a first trial calculation will be made on an approximate

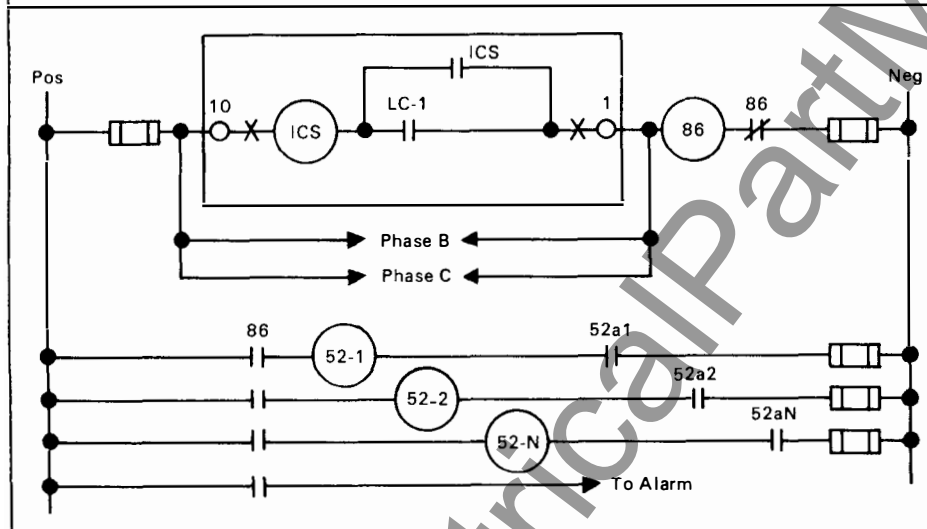

Fig. 36. Trip circuit for LC-1.

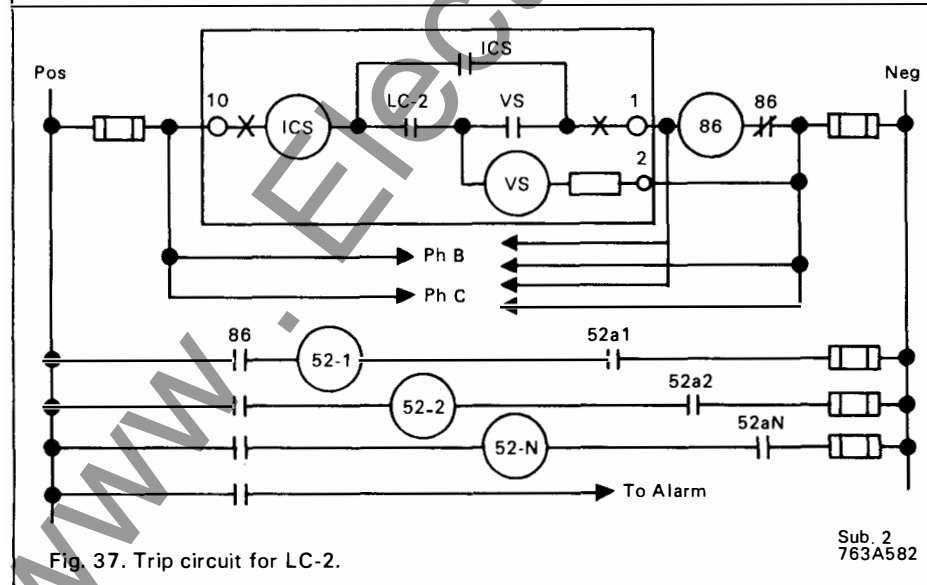

Fig. 37. Trip circuit for LC-2.

Sub. 2  
 763A582

**Device Number Chart**

- 87 — Linear Coupler Bus Differential Relay, Type LC-1 or LC-2
- 86 — Auxiliary Tripping Relay, Type WL
- 52 — Power Circuit Breaker
- 52a — Breaker Auxiliary Contact
- 52TC — Breaker Trip Coil



basis by assuming that the relay impedance is 60 ohms (60 ohm tap) and that this adds arithmetically to the 57.8 ohms of the couplers (leads being neglected).

$$Z_s = 57.8 + 60 = 117.8 \text{ ohms approximately}$$

$$E = I_p M = 2400 \times .005 = 12.0 \text{ volts}$$

$$I_r = \frac{E}{Z_s} = \frac{12.0}{118.8} = .102 \text{ ampere, approximately}$$

Reference to Figure 38 indicates that the relay can be set to operate at .102 (or 0.100 ampere) on either the 60 ohm or 80 ohm tap. Since the desired value is near the minimum obtainable, choose the 60 ohm tap as being the closest match to the value of 57.8 for  $NZ_c$  and make a second more accurate calibration. Using the 60 ohm tap and a contact travel of .075 inches. Values read from the curve give a pickup current  $I_r = 0.100$ ;  $Z_r = 58.3$  ohms, and an impedance angle of  $33^\circ$  for  $Z_r$ .

$$Z_r = 58.3 / 33^\circ = 48.9 + j31.75$$

$$NZ_c = 57.8 / 67.4^\circ = 22.2 + j53.4$$

$$Z_r + NZ_c = \frac{71.1 + j85.15}{111 / 50.1^\circ}$$

From equation (2),  $I_r = \frac{E}{Z_s} = \frac{12.0}{111} = .1081$  ampere

This current is higher than the original assumed current because the calculations were more accurately made, taking into consideration the vector addition of  $Z_r$  and  $NZ_c$ . Changing the contact travel to .080 inch to obtain the pickup current,  $I_r = .107$ , makes an inconsequential change in the relay ohms,  $Z_r = 59$ , and a change of approximately 0.5 in the phase angle of the relay impedance. Another trial calculation is therefore unnecessary from a practical standpoint.

#### LC-2 Setting Example

Assume a six circuit bus has linear couplers with a self-impedance of  $Z_c = 3.7 + j8.9 = 9.64 / 67.4^\circ$ . Three type LC-2 relays are used, one per phase, to obtain phase and ground fault protection. The maximum external fault current is 12,000 amperes rms symmetrical. Since the linear couplers and relays will operate over a 25/1 range with 2 to 1 factor of safety the relays may be set for 480 amperes, which is 1/25 of 12,000.

The LC-2 relay operates with maximum energy when its impedance equals the impedance of the linear coupler circuit

$NZ_c = 6(3.7 + j8.9) = 22.2 + j53.4 = 57.8 / 67.4^\circ$ . Therefore, choose a tap setting  $Z_r = 60$  for the relay, which is an approximate match. Since the phase angle of  $Z_c$  is substantially constant (within 3%) at  $22^\circ$ ,  $Z_r = 60 / 22^\circ = 55.6 + j22.5$ .

$$NZ_c = 22.2 + j53.4$$

$$Z_r = 55.6 + j22.5$$

$$Z_s = 77.8 + j75.9 = 108.8 \text{ ohms}$$

$$I_p M = 480 \times .005 = 2.4 \text{ volts}$$

From equation (3) page 15,

$$I_r = \frac{I_p M}{Z_s} = \frac{2.4}{108.8} = .0221 \text{ amperes}$$

This is within the recommended setting range of the relay as indicated in Figure 39.

On the 60 ohm tap, at  $I_r = .0221$ ,  $Z_r = 54.5 / 22^\circ = 50.6 + j20.4$ .

This new value of  $Z_r$  should be used in equation (3).

$$NZ_c = 22.2 + j53.4$$

$$Z_r = 50.6 + j20.4$$

$$Z_s = 72.8 + j73.8 = 103.6 \text{ ohms}$$

$$I_r = \frac{I_p M}{Z_s} = \frac{2.4}{103.6} = .0232 \text{ amperes}$$

At  $I_r = .0232$  on the 60 ohm tap, Figure 40 indicates that  $Z_r = 54$  ohms. Since a value of  $Z_r = 54.5$  was used in the above calculation, it is not necessary to carry the calculation any further.

The relay should be adjusted to trip at  $I = .0232$  amperes on the 60 ohm tap using the magnetic shunts at the rear of the polar element assembly.

#### In Service Test Facilities for LC Relay Schemes

The linear coupler differential circuit can be provided with a test scheme to check the differential circuit while the bus is carrying load. Defects such as short circuited linear coupler transformers, ground faults and open circuits in the secondary loop, wrong polarity or phasing connections in the linear couplers, severe steady state voltage effects from foreign sources can be detected. For further details, refer to Instruction Leaflet 41-342.1.

#### Further Information

Descriptive Bulletin 41-342.  
Instruction Leaflet 41-342.1.

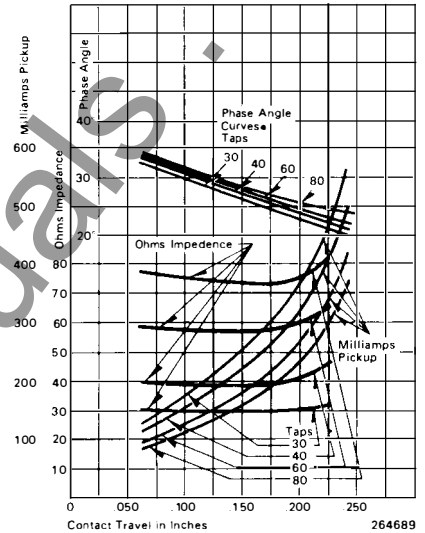

Fig. 38. LC-1 characteristic curve.

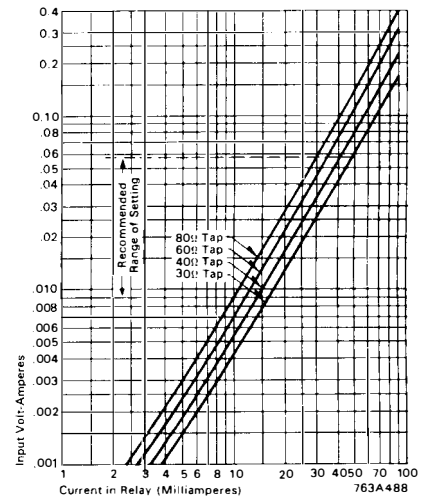

Fig. 39. LC-2 volt-ampere curve.

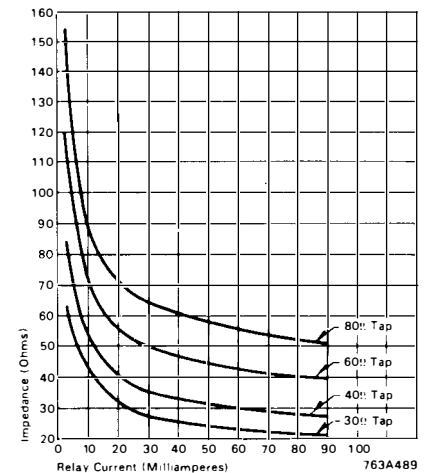

Fig. 40. LC-2 Relay Impedance Curve (impedance at  $22^\circ$  angle).

**Type KAB, single phase  
 instantaneous, high speed**

The type KAB relay is an instantaneous relay of the high impedance type used for bus differential protection. This relay also can be applied for generator or shunt reactor differential schemes.

The type KAB relay can be applied for bus protection in most cases where bushing type ct's are in use, and in metal-clad equipment where ct's with toroidally wound cores having their windings completely distributed are employed. Fig. 41 shows the external connection.

The following points should be considered or should be known on any proposed type KAB relay application:

1. All ct's in the bus differential circuit should have the same ratio, and should be operated on their full tap. If tap connection cannot be avoided, the winding section between the taps being used must be fully distributed and the

high voltage which may appear at the full tap terminal due to the auto-transformer action should be checked.

2. The leakage impedance of the ct's which are to be used should be low.
3. The use of the auxiliary ct's is not recommended. If this cannot be avoided the additional impedance from the auxiliary ct's and the high voltage which is transformed by the auxiliary ct should be checked.
4. The best location for the junction points is equidistant from all ct's.
5. The lead resistance from the junction points to the relay terminals is not critical.
6. A lockout relay contact is recommended to short circuit the varistor following the relay operation in order to prevent the varistor from overheating.
7. To insure a substantial margin of operation on internal faults, the V-unit should not be set higher than the knee voltage,  $V_k$ , (value of the *poorest* ct which is connected to the relay).

To insure a substantial margin for preventing the relay from operating on external faults, the knee voltage value of the *best* ct which is connected to the relay should be used to determine the value of  $(R_s + R_L) I_f / NV_k$  in Fig. 42.

The knee voltage is defined as the interaction of the extension of the two straight line portions of the saturation curve, ordinate and abscissa must be same scale for each decade.

8. A high voltage may be developed across the relay on internal faults. The magnitude of the voltage that can be developed is a function of the total fault current and the characteristics of the cts used in the differential circuit. The varistor which is built into the relay is used to limit this high voltage to a safe level. Curves in Figure 43 should be used to investigate the application limit for one-disc and four-disc relays.

If the fault current  $\frac{I_f}{N}$  and knee point voltage ( $V_k$ ) are such that the intersection of these two points plot below the curve, then the application will be safe with respect to the limits for 4-cycle clearing time. (Note that the one-disc type relay has a higher capability in application than the four-disc relay).

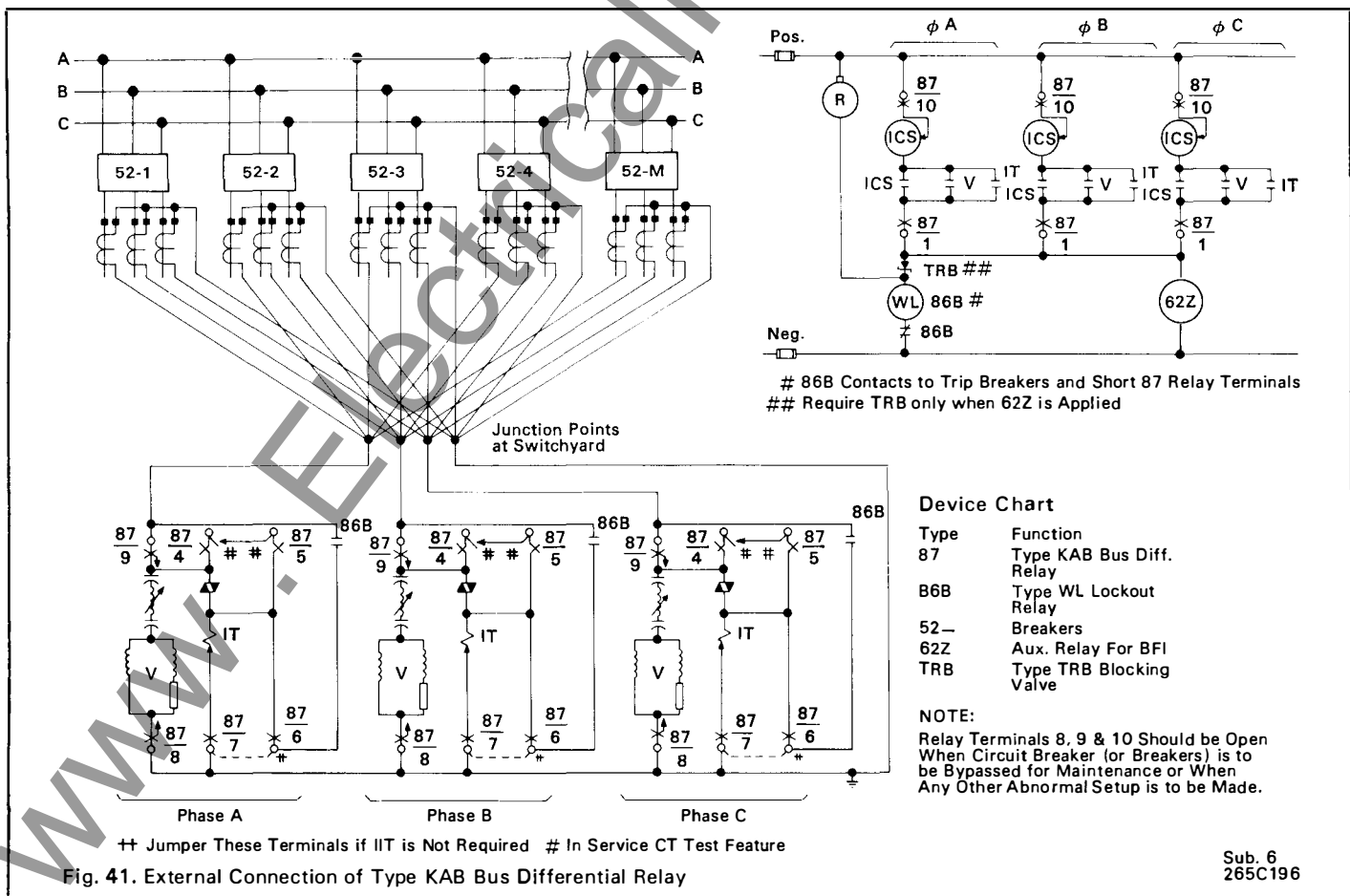

Fig. 41. External Connection of Type KAB Bus Differential Relay



9. The maximum number of circuits which can be connected to the relay or the minimum internal fault current required to operate the relay can be estimated from the following equation.

$$I_{min.} = (X I_e + I_R + I_v) N$$

where  $I_{min.}$  = minimum internal fault currents, RMS.

$I_e$  = ct. secondary excitation current at a voltage equal to the setting value of V-unit.

$I_R$  = Current in V-unit at setting voltage  $V_R$  (i.e.  $I_R = V_R / 2600$ )

$I_v$  = Current in varistor circuit at voltage equal to the setting value of V-unit. Use Fig. 43 for determining  $I_v$ .

$N$  = ct turn's ratio.

$X$  = Number of circuits connected to the bus.

The relay is connected as shown in external connection figure 41. In normal operation the voltage at the relay terminals is approximately zero. In the case of an external fault, the voltage at the relay terminals still remain approximately zero if both the source ct's and the faulted ct's are not saturated.

However, during severe external faults the faulted ct may saturate and no voltage or current can be developed from its secondary winding. The source ct's would then have to force their currents..

In the case of internal faults, the feeder ct's impedances neglecting the load current, are equal to the magnetizing impedance which is high. Since the relay is a high impedance type, this makes a high impedance secondary burden to the source ct's, a high voltage will appear at the relay terminals and will be above the pickup setting.

#### Characteristics

Single phase, 60 or 50 Hz, Spst-cc contact, FT-21 Flexitest case.

Overvoltage unit: Range 75-300 volts adjustable operating speed 1.5 cycles.

Instantaneous overcurrent unit: Range 3-48 amperes. Operating speed 1.0 cycle.

Indicating contactor switch (ICS) 0.2/2.0 amperes.

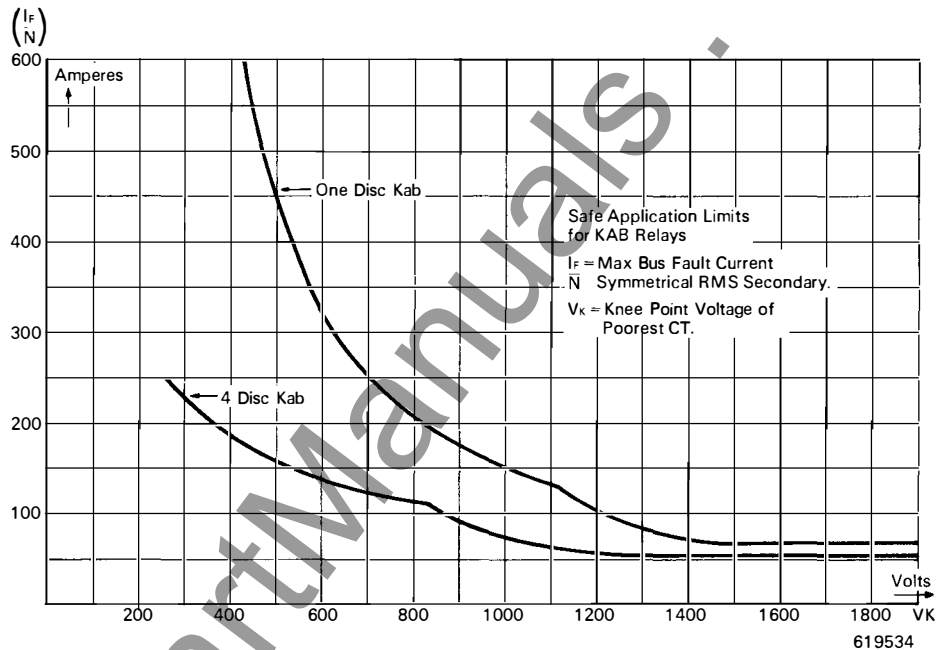

Fig. 42. Safe Application Limits for KAB Relays.

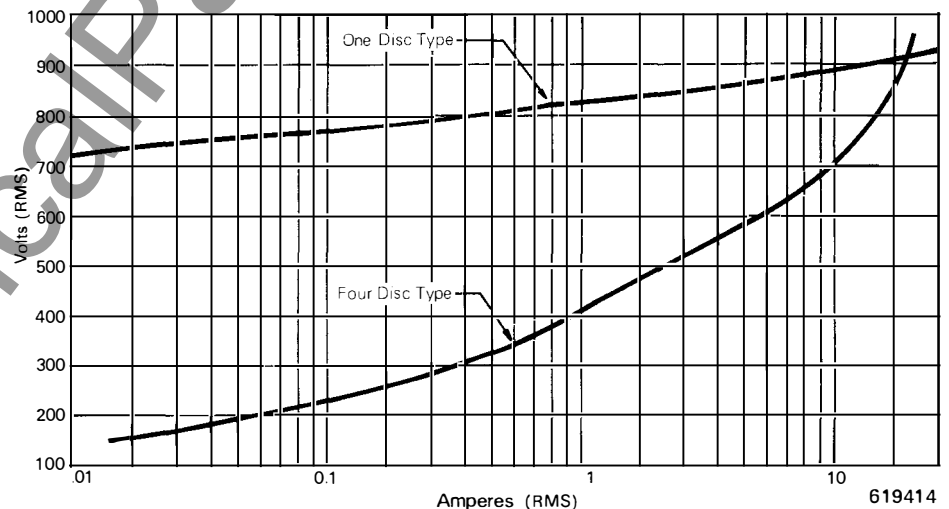

Fig. 43. Typical Volt-Ampere Characteristics of Varistor in Type KAB Relay (RMS).

**Setting Calculations**

**1. SETTING VOLTAGE UNIT**

The setting of the voltage unit can be expressed as follows:

$$V_R = K (R_s + R_L) \frac{I_f}{N}$$

where  $V_R$  = pick up setting of the V-unit, (RMS volts.)

$R_s$  = dc resistance of ct secondary winding, including internal leads to bushing terminals.

$R_L$  = resistance of lead from junction points to the most distant ct (One-way lead for phase fault, two way lead for phase to ground fault).

$I_f$  = Maximum external fault current (RMS amp.) contributed by the bus.

$N$  = ct turn's ratio.

$K$  = Margin factor

The margin factor is a modification number. It varies with the reciprocal of the ct saturation factor, i.e.  $\frac{(R_s + R_L) I_f}{N V_k}$

Figure 44 shows the margin factor curve, which is based on tests on the KAB relay and considers a safety factor of 2. The use of this curve is explained in the sample calculation.

**2. SETTING CURRENT UNIT**

The setting calculation for this unit is rather simple. First, calculate the value of

$$(R_s + R_L) \left[ \frac{I_f}{N} \right]$$

then from curves in Fig. 45 find the value for the setting. These curves have considered a safety factor of 2.

**3. Sample Calculation:**

Assume a 6 circuit bus, for which the maximum external 3-phase fault current is 60,000 amperes rms, symmetrical, maximum external phase to ground fault current is 45,000 amperes, and the minimum internal fault current is 10,000 amperes. Assume the ct's ratios are 2000:5, class C400,  $V_k = 375$  volts, secondary winding resistance  $R_s = 0.93$  ohm, and one way lead resistance to junction point  $R_L = 1.07$  ohm.

From Figure 43, for  $\frac{I_f}{N} = 150$  A and  $V_k = 375$  V, it can be seen that either one-disc type or four-disc type KAB relay would be satisfactory for this application.

**A. SETTING OF CURRENT UNIT**

Since  $(R_s + R_L) \frac{I_f}{N} = (0.93 + 1.07) \times \frac{60000}{400} = 300$

for 3-phase fault.

$(R_s + R_L) \frac{I_f}{N} = (0.93 + 2 \times 1.07) \times \frac{45000}{400} = 345$

for phase to ground fault.

From Figure 45 using the higher number of 345 the current unit setting is determined to be 43 amperes for 4 disc KAB and 12 amperes for one disc KAB. Set the overcurrent unit at 45 amp. and 15 amp. respectively.

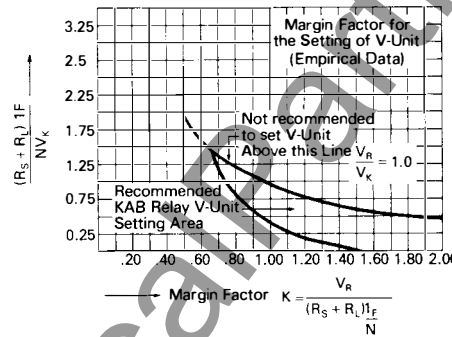

Fig. 44. Margin Factor for V-Unit Setting.

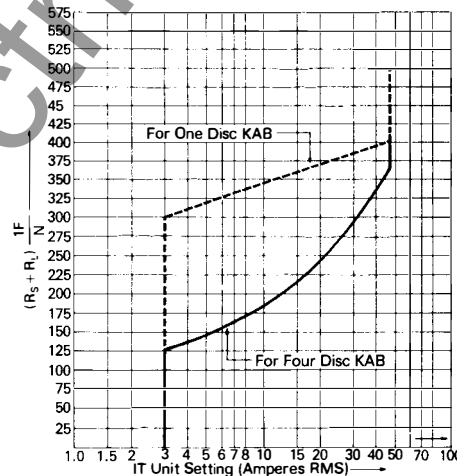

Fig. 45. IT-Unit Setting

Sub. 5  
 1468C41

**B. SETTING OF VOLTAGE UNIT**

a.) for 3-phase fault condition.

$$\left[ (R_s + R_L) \frac{I_f}{N} \right] / V_k = \left[ (0.93 + 1.07) \times \frac{60000}{400} \right] / 375 = 0.8$$

from Fig. 44  $K \geq 0.82$

$$V_R \geq K (R_s + R_L) \frac{I_f}{N}$$

$$V_R \geq 0.82 (0.93 + 1.07) \times \frac{60000}{400} = 246 \text{ Volts.}$$

b.) for phase to ground fault condition

$$\left[ (R_s + R_L) \frac{I_f}{N} \right] / V_k = \left[ (0.93 + 2 \times 1.07) \times \frac{45000}{400} \right] / 375 = 0.92$$

from Fig. 44  $K \geq 0.77$

$$V_R \geq K (R_s + R_L) \frac{I_f}{N}$$

$$V_R \geq 0.77 (0.93 + 2 \times 1.07) \times \frac{45000}{400} = 266 \text{ volts.}$$

Choose the maximum of (a) and (b), to prevent the relay from false pickup on external faults. Its minimum setting should be at least this maximum 266 volts. This adjustment is made by varying the spring tension. See "Routine Maintenance" (in IL-41-337.4)

c.) the minimum fault current required to operate the relay at the setting of 266 volts.

Assume that from the ct saturation curve  $I_e = 0.045$  amp. at 266 volts. And from Fig. 43  $I_v = 0.16$  amp. at 266 volts. (RMS for 4 disc type KAB.)

$$I_{min.} = (X I_e + I_r + I_v) \cdot N$$

$$= (6 \times 0.045 + \frac{266}{2600} + 0.16) \cdot 400$$

$$= 0.532 \times 400 = 213 \text{ amp.}$$

For one-disc type KAB,  $I_v$  is less than at 266 volts. Therefore,  $I_{min.} = 149$  amp.

**Further Information**

Descriptive Bulletin 41-340  
 Instruction Leaflet 41-337.4



### Transformer Differential Relays

Power transformers have a high and a low voltage winding (2-winding), with some having an intermediate voltage winding (3-winding), and the current transformers associated with each winding will have different ratings and operating characteristics, particularly on heavy overloads and short circuit conditions. For this reason, transformer differential relays are usually provided with "ratio" taps to balance the difference in current transformer characteristics. In some applications, auxiliary auto-balancing transformers are used.

In addition to the problem of matching the high and low side current transformer characteristics, the problems of magnetizing inrush to the power transformer must also be considered.

2- and 3-winding transformers require different differential protective relay schemes, and a regulating transformer still another. Each of the relays covered in this section has its specific field of application, and proper selection and application may be easily made from the following information.

**Type CA Single Phase, 2-Winding,  
Inverse Timing, Constant Percentage**

Basic external connections for the CA relay are shown in Figure 46.

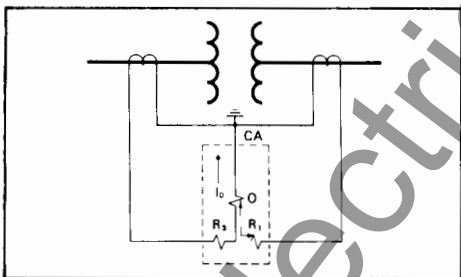

Connected as shown, under normal conditions current passes through the current transformers, relay restraining coils  $R_1$  and  $R_2$ , and back to the current transformers. This current in the relay restraining coils produces a restraining, or contact opening torque.

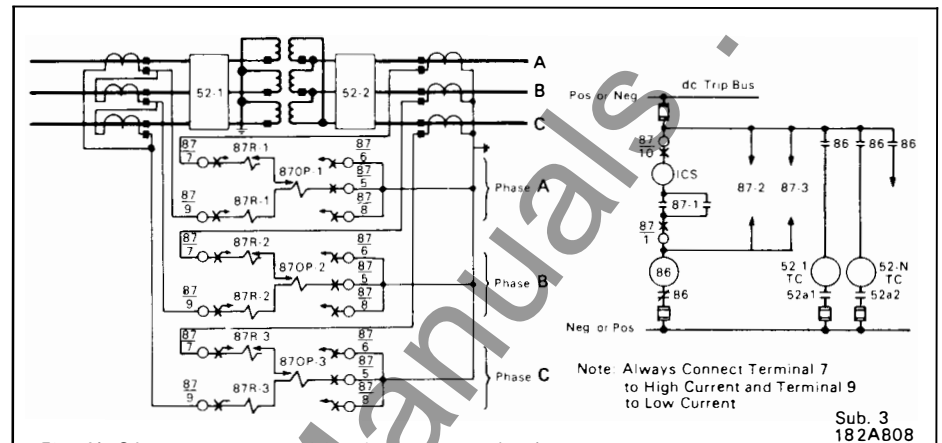

Fig. 47. CA relay external wiring for wye-delta bank.

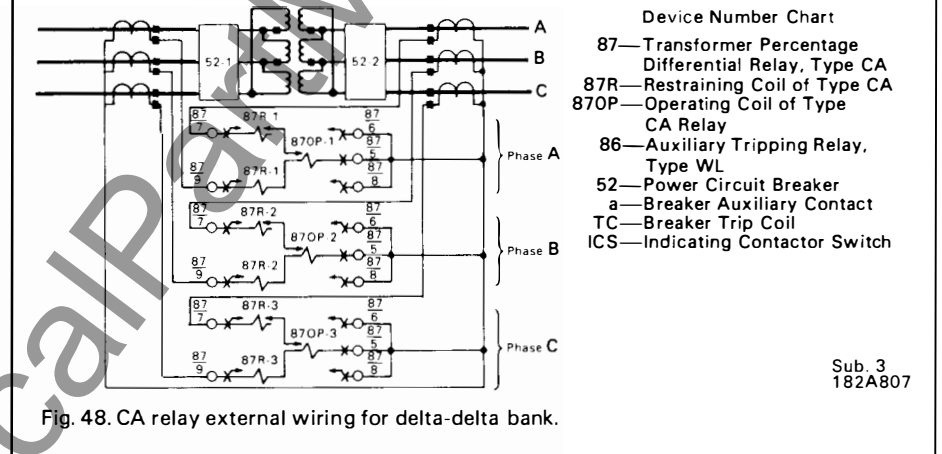

Fig. 48. CA relay external wiring for delta-delta bank.

- Device Number Chart
- 87—Transformer Percentage Differential Relay, Type CA
  - 87R—Restraining Coil of Type CA
  - 87OP—Operating Coil of Type CA Relay
  - 86—Auxiliary Tripping Relay, Type WL
  - 52—Power Circuit Breaker
  - a—Breaker Auxiliary Contact
  - TC—Breaker Trip Coil
  - ICS—Indicating Contactor Switch

An internal fault in the protected power transformer will unbalance the secondary currents, forcing a differential current  $I_D$  through the relay operating coil  $O$ . The amount of differential or operating current required to overcome the restraining torque and close the relay contacts is a fixed percentage of the smaller restraining current.

External wiring diagrams are shown in Figures 47 and 48.

**Characteristics**  
Single phase, 50 to 60 hertz, spst-cc or dpst-cc contacts, FT-21 Flexitest case 2-winding transformer protection Inverse time characteristics

Operating time: see Fig. 51  
2 restraining and 1 operating circuit

Ratio taps: 5-5, 5-5.5, 5-6, 5-6.6, 5-7.3, 5-8, 5-9, 5-10

Constant percentage differential

Sensitivity: 50% unbalance

Minimum trip: on 5-5 tap, terminals 9 and 5—2.7 to 2.8 amperes  
on 5-5 tap, terminals 7 and 5—2.9 to 3.2 amperes

Burden: see Figures 53 and 54

Thermal rating:  
Restraining circuits—10 amperes continuous (the untapped winding should be limited to 5 amperes to prevent overloading of the operating winding)

Operating circuit—5 amperes continuous.

**Relay Settings**

To determine the correct tap setting, calculate the current delivered to the relay at full load on the transformer bank, taking into consideration not only the current transformer ratios, but also any delta connections which may be used. These currents will be in a certain ratio and the relay taps should be chosen to match this as closely as possible.

For example, assume that the currents are 7.8 and 4.6 amperes, and the relay is properly connected so that the higher current (7.8 amperes) flows in the tapped restraining winding. The ratio 4.6/7.8 is equal to 5/8.47. The nearest tap ratio on the relay is 5-8, and this pair of taps would be used.

The time dial should be set on the number 1 position.

Operating characteristics of the CA relay for normal through load current and through fault current are shown in Figures 49 and 50. When the currents flowing in and out of the relay are plotted on these curves and the point falls outside of the inoperative area the relay will trip.

In Figures 49 and 50, the two curves going with the 5-5 tap are tied together with a bracket to indicate that these two curves go together. Similarly, the two curves for the 5-10 tap are also tied together. The center lines between pairs of curves are shown for all taps. The paired curves bounding the inoperative areas are not shown for the 5-5.5 through 5-9 taps.

These curves may be approximately determined by using the following formula:

for the upper curve:  $I_9 = \frac{7.5I_7}{T}$  (1)

for the lower curve:  $I_7 = 0.37I_9$  (2)

In these formulas, T is the larger number of the tap pair. For example, if the relay is set on the 5-7.3 tap, then T=7.3.

As an example of the accuracy of the formula, consider the point  $I_7 = 43.5$  and  $I_9 = 30$ , and read from the lower curves for the 5-5 tap in Figure 50. Applying the formula, equation (2), the calculated value of  $I_7$  is found to be 45, which is fairly close to the curve value  $I_7$  of 43.5.

**Further Information**  
Descriptive Bulletin 41-332

Instruction Leaflet 41-332.2

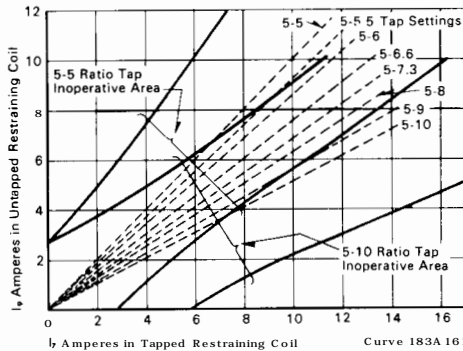

Fig. 49. CA relay typical operating curves, low current values.

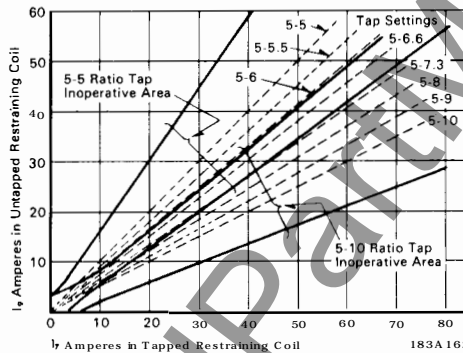

Fig. 50. CA relay typical operating curves, high current values.

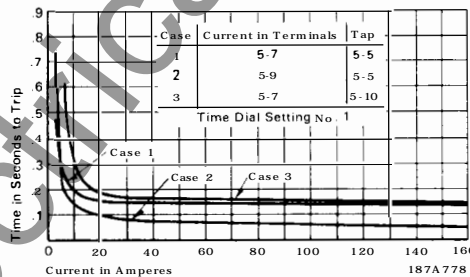

Fig. 51. CA relay typical time curves.

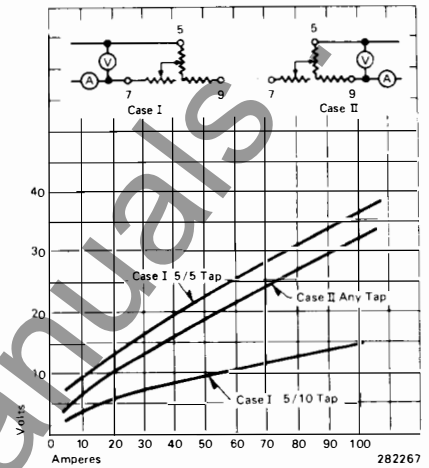

Fig. 52. CA relay typical saturation curves.

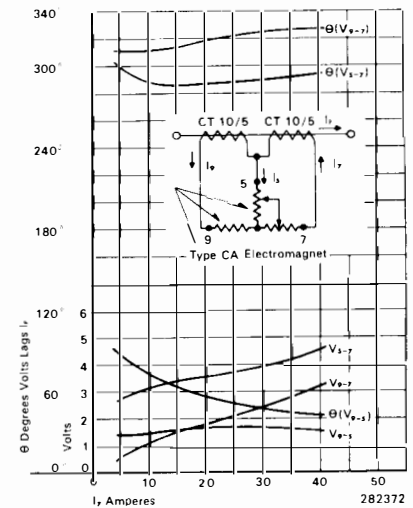

Fig. 53. CA relay typical burden curve, 5/5 tap.

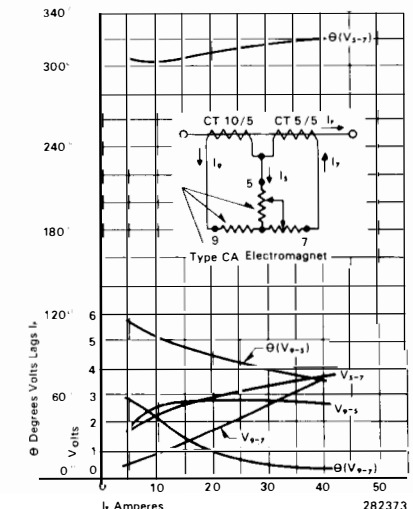

Fig. 54. CA relay typical burden curve, 5/10 tap.



**Type CA-26 Single Phase, 2 or 3 Winding, Inverse Timing, Variable Percentage**

The CA-26 may be used for differential protection of either a 2 or a 3-winding power transformer. It has three restraining circuits for use in either of these applications.

The variable percentage ratio characteristic provides high sensitivity at low current magnitudes, with an increase in percentage ratio at the higher currents. It will therefore detect light internal faults within the transformer and at the same time allows for variation in current transformer performance at high external fault currents thereby preventing false tripping on heavy

external faults. This characteristic is particularly desirable when severe saturation of the current transformers occurs due to the dc component of asymmetrical short circuits.

A typical external connection diagram is shown in Figure 59.

**Characteristics**  
Single phase, 50 or 60 hertz, spst-cc or dpst-cc contacts, FT-32 Flexitest case.

Operating time: see Figure 58.  
Three restraint circuits, one operating circuit. No ratio taps.

Variable percentage characteristics: see Figures 55 and 56.

Minimum trip: 1.25 amperes.

**Burden:**  
Each restraint circuit—0.75 volt-amperes at 5 amperes, 14 amperes continuous rating; 460 amperes 1 second rating.

**Operating circuit—**see Figure 57, 8 amperes continuous rating; 280 amperes 1 second rating.

**Relay settings:** none required, except to select the proper tap on the Indicating Contactor Switch (ICS).

**Performance curves:** see Figures 55 to 58.

**Further Information**  
Descriptive Bulletin 41-337.

Instruction Leaflet 41-337.3.

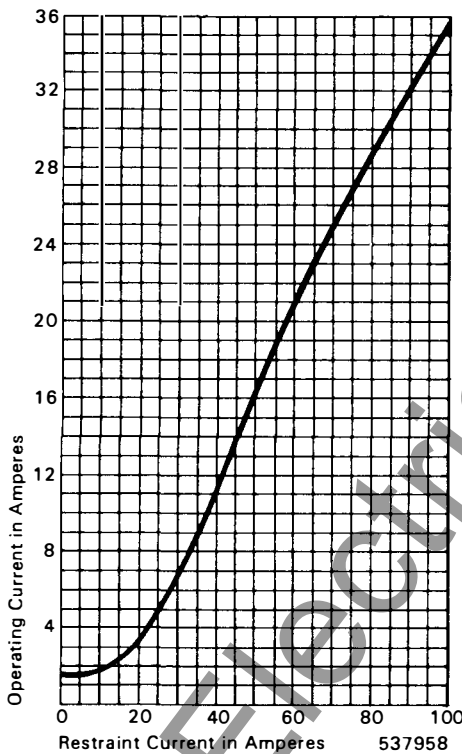

Fig. 55. CA-26 relay variable percentage slope curve with one restraint winding.

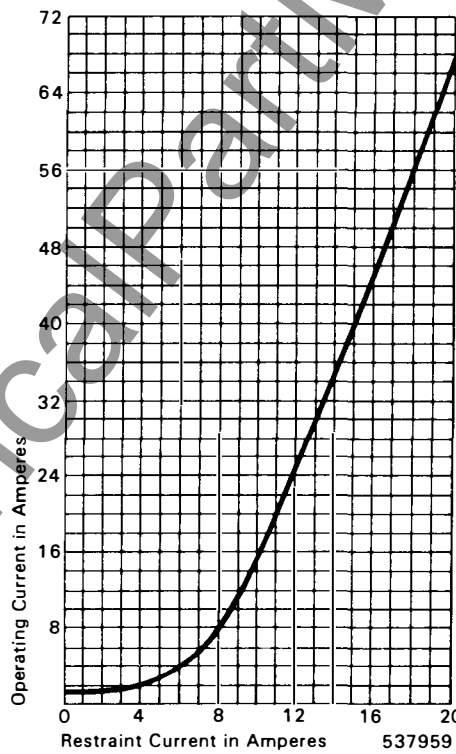

Fig. 56. CA-26 relay variable percentage slope curve with six restraint windings in series.

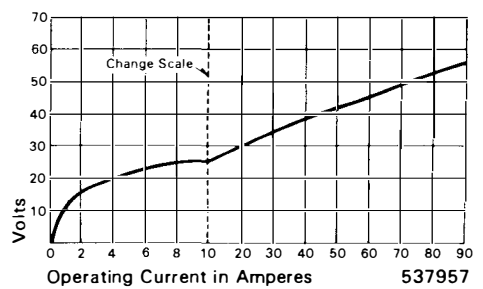

Fig. 57. CA-26 relay typical burden curve.

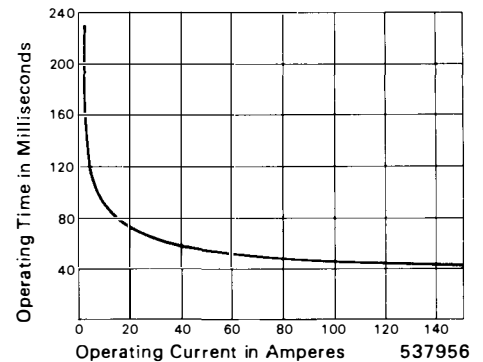

Fig. 58. CA-26 relay typical time curve.

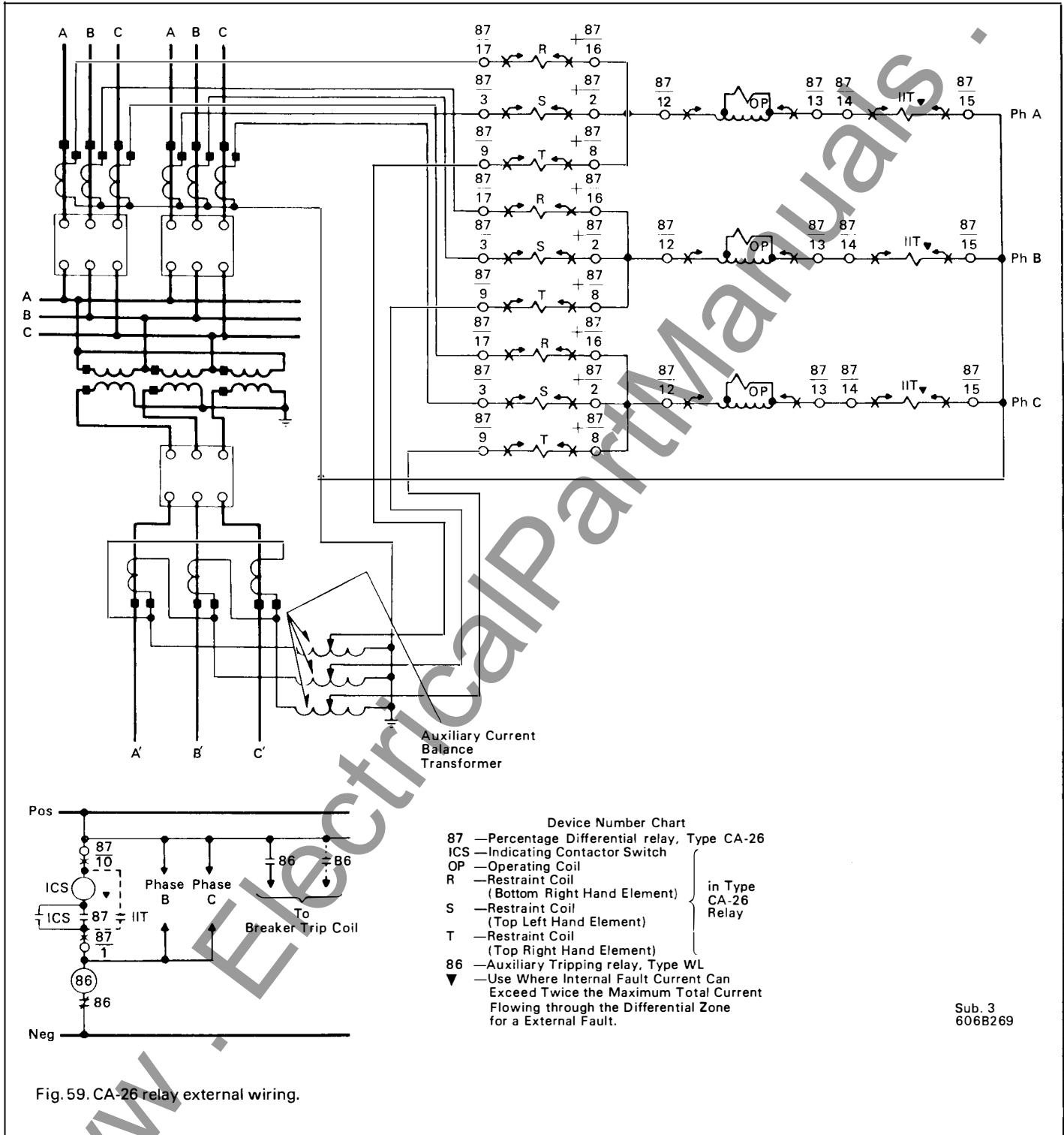

Fig. 59. CA-26 relay external wiring.

Sub. 3  
606B269



**Type HU, HU-1 HU-4 Single Phase,  
2 or 3 Winding, Instantaneous,  
Variable Percentage**

These relays are high speed differential units with two, three or four restraint circuits respectively; all incorporating a harmonic restraint circuit to prevent false tripping on magnetizing inrush current.

They are all designed with a variable percentage ratio characteristic which provides high sensitivity at low current magnitudes, with an increase in percentage ratio at the higher currents. Each relay will, therefore, detect light internal faults within the transformer and at the same time prevent false tripping on heavy external fault currents which may cause variation in the current transformer performance at high currents. This is particularly desirable when severe saturation of the current transformers occurs due to the dc component of asymmetrical short circuits.

The harmonic restraint feature prevents false tripping on magnetizing inrush currents which appear at the relay as an internal fault. These inrush currents are rich in harmonics, with the second harmonic predominant. Since the second harmonic is always present in magnetizing inrush currents, and not in internal fault current waves, the second harmonic is used in these relays to restrain the relay on inrush.

Normal application of these relays is as follows:  
2-winding transformer: type HU  
3-winding transformer: type HU-1  
4-winding transformer: type HU-4  
Transformer with four breakers: type HU-4

All HU type relays are available with a sensitivity of either 0.30 or 0.35 times tap rating. The 30% sensitivity relay satisfactorily handles up to 15% mismatch (e.g.  $\pm 10\%$  transformer tap changing, plus 5% current transformer mismatch). The 35% unit handles up to 20% mismatch. See Figures 60 to 65 for comparison of these two sensitivity characteristics.

Either characteristic may be obtained on any one of these relays by recalibration in the field.

Taps are provided in each restraint and operating circuit to compensate for current transformer mismatch. These tap settings are marked in terms of secondary amperes and these values are listed in "characteristics" below.

A typical external connection is shown in Figure 67.

**Characteristics**  
(Type HU-4 characteristics are the same as those for type HU and HU-1 except where noted otherwise).

Single phase, 50 or 60 hertz, spst-cc or dpst-cc contacts, HU-HU-1—FT-31 Flexitest case, HU-4—FT-42 Flexitest case.

Operating time: see Figure 65.

Restraint circuits: 2 in HU, 3 in HU-1, 4 in HU-4, plus one harmonic restraint. One operating circuit in each.

Ratio Taps: 2.9, 3.2, 3.5, 3.8, 4.2, 4.6, 5.0, 8.7 ampere taps on each restraint circuit.

Variable percentage characteristics:  
Types HU and HU-1—See Figures 60 and 61

Type HU-4—see Figure 62.

Minimum trip :30% or 35% of tap value.

Performance curves: see Figures 60 to 66.

**Energy Requirements**

Tap	Con- tinuous Rating	Power Factor Angle ①	At Tap Value Current	Volt-Amperes②	
				At 8 Times Tap Value Current	At 20 Times Tap Value Current
<b>Burden of Each Restraint Circuit</b>					
2.9	10	71	.88	50	191
3.2	12	70	.89	51	211
3.5	13	66	.90	51	203
3.8	14	65	.91	53	220
4.2	15	58	.91	53	235
4.6	16	57.5	.91	55	248
5.0	18	52.5	.92	59	280
8.7	22	30	1.28	94	340

<b>Burden of Operating Circuit</b>					
2.9	10	35	2.26	76	487
3.2	12	34	2.30	78	490
3.5	13	33	2.30	81	504
3.8	14	33	2.30	83	547
4.2	15	31	2.30	84	554
4.6	16	30	2.40	88	598
5.0	18	29	2.50	92	640
8.7	22	23	3.18	132	850

① Degrees current lags voltage at tap value current.  
② Voltages taken with Rectox type voltmeter.

Thermal rating: 300 amperes 1 second (thermal capacities for short times other than one second may be calculated on the basis of time being inversely proportional to the square of the current).

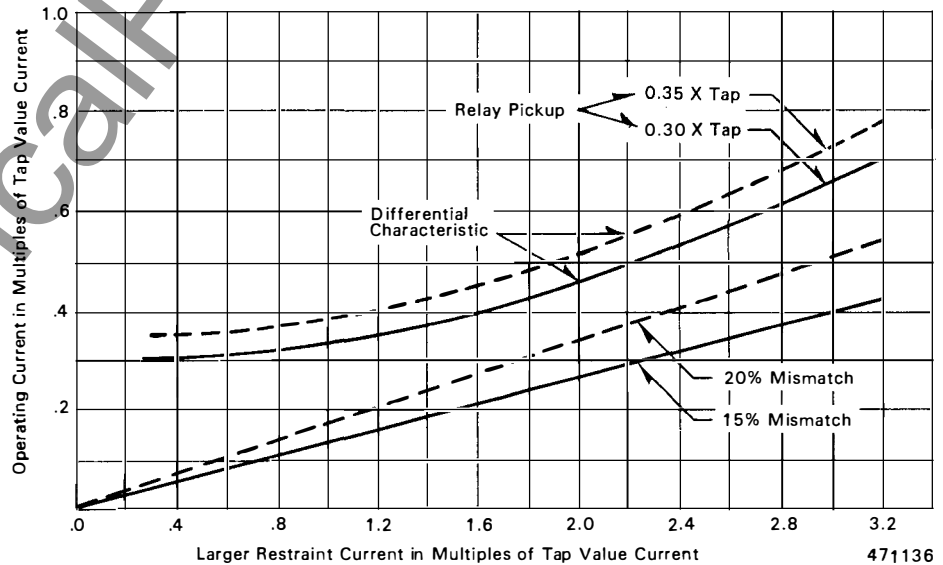

Fig. 60. Types HU, HU-1 differential unit characteristics, smaller current values.

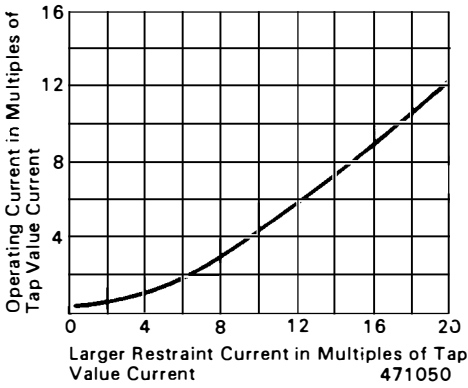

Fig. 61. Types HU, HU-1 differential unit characteristics, larger current values.

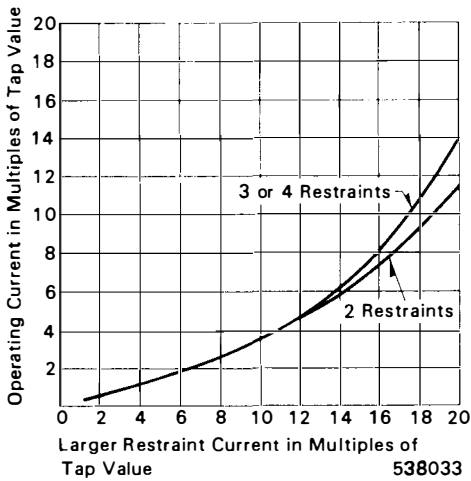

Fig. 62. Type HU-4 relay differential unit characteristics of DU unit.

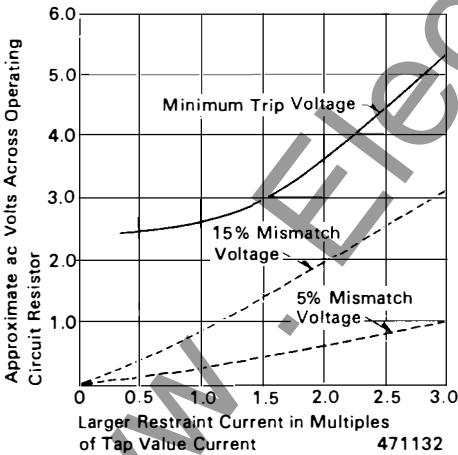

Fig. 63. Types HU, HU-1 differential voltage characteristics of DU unit, .03 times tap value pickup.

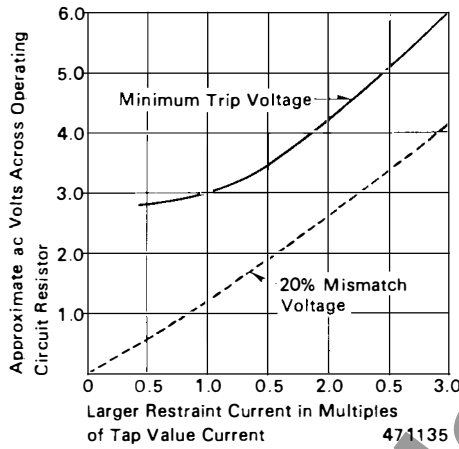

Fig. 64. Types HU, HU-1 differential voltage characteristics of DU unit, 0.35 times tap value pickup.

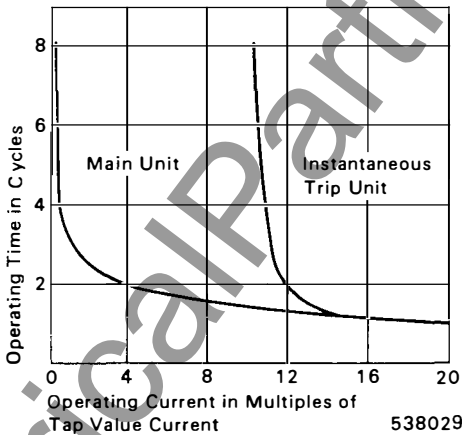

Fig. 65. Types HU, HU-1 relay typical operating time curve.

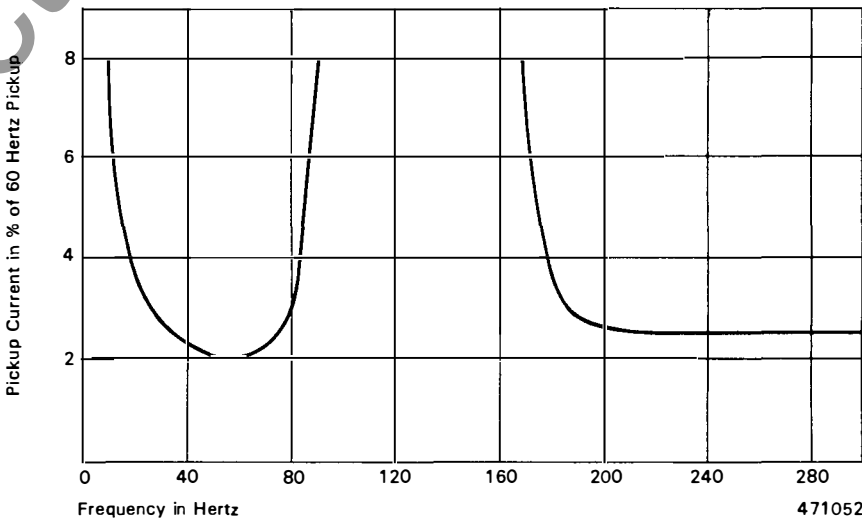

Fig. 66. Pickup on variable frequency type HU, HU-1 and HU-4 relays.

**Relay Settings**

Select the ratio in matching taps. In order to calculate the required tap settings and check current transformer performance, the following is required:

**Required Information**

1. Maximum transformer rating (KVA)<sub>M</sub>.
2. Maximum external fault currents.
3. Voltage ratings of power transformer (V<sub>H</sub>, V<sub>L</sub>, V<sub>L</sub>).
4. Current transformer ratios.
5. Current transformer accuracy class voltage (or excitation or ratio-overcurrent curve).
6. One way current transformer lead resistance at 25°C (when using excitation curve, include current transformer winding resistance).
7. Current transformer connections (wye or delta).

**Definition of Terms**

$I_p$  = primary current at (KVA)<sub>M</sub>

$I_s$  = current transformer secondary current at (KVA)<sub>M</sub>

$I_R$  = relay input current at (KVA)<sub>M</sub>

$I_{RH}$ ,  $I_{RL}$ ,  $I_{RI}$  are same as  $I_R$  except for high, low, and intermediate voltage sides, respectively.



**Definition of Terms (continued)**

$T_H, T_L, T_I$  = relay tap settings for high, low, and intermediate voltage windings, respectively.

$N$  = number of current transformer turns that are in use.

$N_p = N/N_T$  (proportion of total turns in use)

$N_T$  = current transformer ratio, full tap.

$V_{CL}$  = current transformer accuracy class voltage C or 10L.

$Z_A$  = burden impedance of any devices other than HU or HU-1 relays with maximum phase-to-phase or 3 phase current flowing.

$Z_T$  = total secondary burden in ohms (excluding current transformer winding resistance, except when using excitation curve).

**Calculation Procedure**

1. Selection current transformer taps where multi-ratio types are used. Select a tap to give approximately 5 amperes at maximum load current. This will provide good

sensitivity and will produce no thermal problem to the CT, the leads, or the relays.

Better sensitivity can be achieved by selecting a tap to give more than 5 amperes if a careful check is made of the CT, the leads and the relay capability.

For determining the required continuous rating of the relay, use the expected two-hour maximum load, since the relay reaches final temperature in this time.

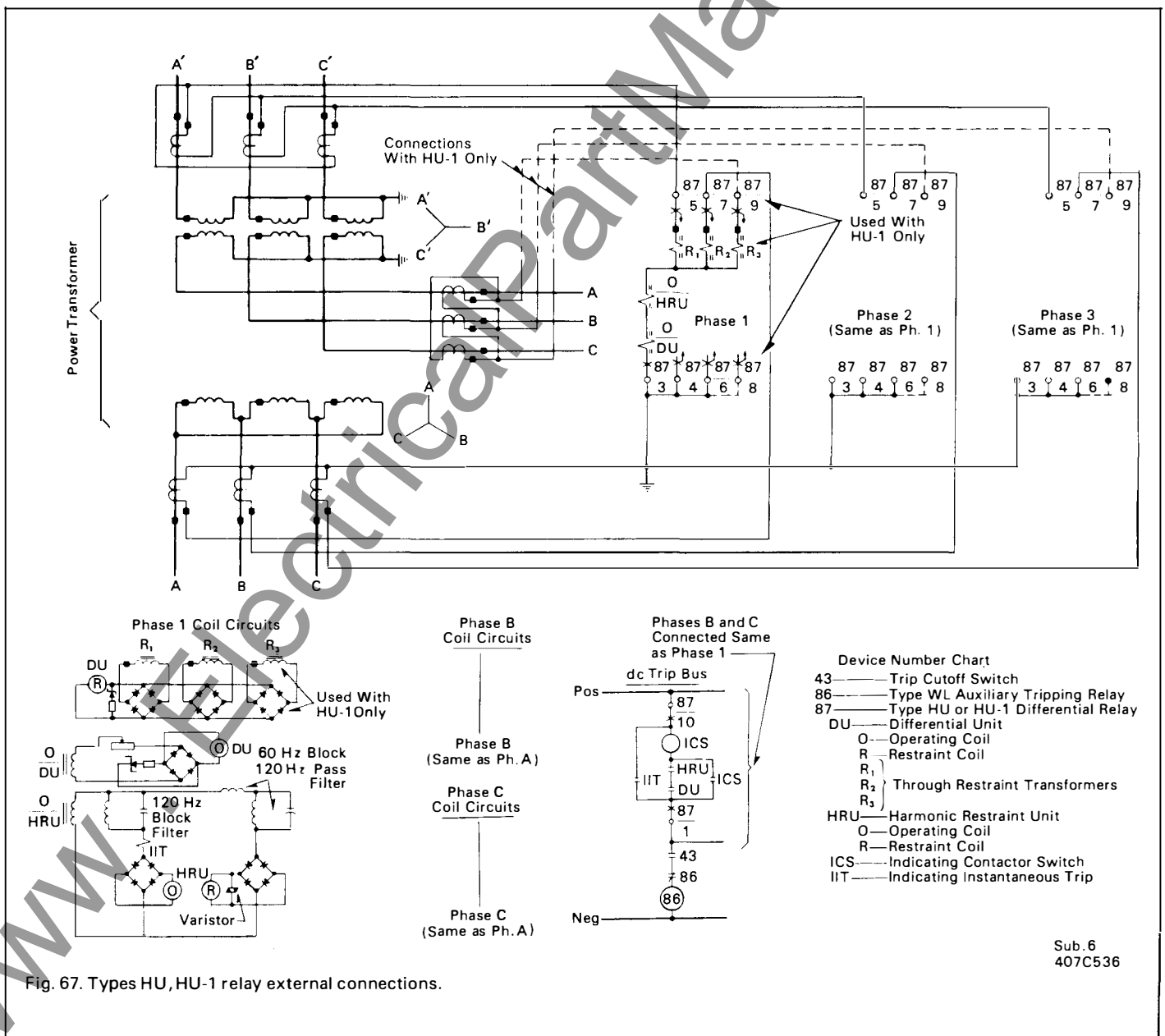

Fig. 67. Types HU, HU-1 relay external connections.

- Calculate the Relay Currents,  $I_R$   
All relay currents for relay tap selection should be based on the same KVA capacity.
- Calculate the Relay Current Ratio(s) using the lowest current as reference.
- Select relay tap ratio as close as possible to relay current ratio from Table 1.

Choose the first relay tap ratio using the largest current ratio from Step 3. The other tap ratios should be determined using the lower tap from the first tap ratio as reference.

$I_R$  should not exceed relay continuous rating as defined in Energy Requirement Table.

- Check IIT Operation. The IIT pickup is ten times the relay tap value for the HU and HU-1, or 15 times tap value for the HU-4. Therefore, the maximum symmetrical error current which is flowing in the differential circuit on external fault current due to dissimilar ct saturation should not exceed 10 or 15 times relay tap.

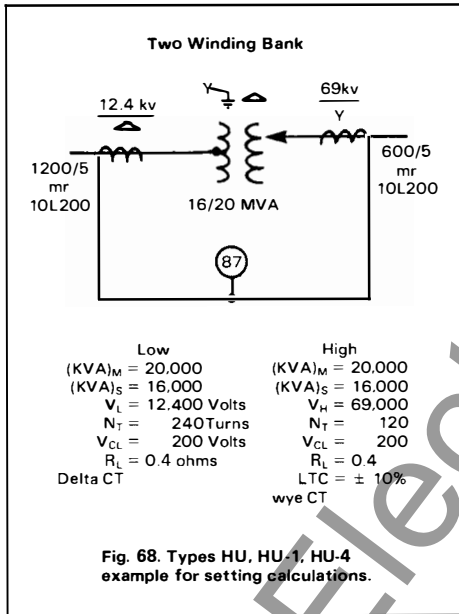

**Two-Winding Transformer Calculations (See Figure 68).**

	Low	High
1. Select CT Ratio:		
$I_P = \frac{(KVA)_M}{(KV) \sqrt{3}}$	$\frac{20,000}{12.4 \sqrt{3}} = 930$ Amp.	$\frac{20,000}{69 \sqrt{3}} = 167$ Amp.
Select Ratio	1000/5 (N=200)	200/5 (N=40)
2. Calculate Relay Current:		
$I_S = \frac{I_P}{N}$	$\frac{930}{200} = 4.65$ Amp.	$\frac{167}{40} = 4.18$ Amp.
$I_{RL} = I_S \sqrt{3}$	$4.65 \sqrt{3} = 8.05$ Amp.	$I_{RH} = 4.18$ Amp.
3. Calculate Current Ratio:		
$\frac{I_{RL}}{I_{RH}} = \frac{8.05}{4.18} = 1.93$		
4. Select Tap Ratio from Table 1:		
$I_R > \text{relay continuous rating}$	No	No
5. Check IIT Operation:		
Max. symmetrical error current > 10 times relay tap	No	No
6. Determine Mismatch:		
% Mismatch = $100 \frac{(I_{RL}/I_{RH}) - (T_L/T_H)}{T_L/T_H}$		
	$100 \frac{(8.05/4.18) - (8.7/4.6)}{8.7/4.6} = 1.6\%$	
7. Check CT Performance:		
$Z_T = 3.4 R_L + \frac{0.45}{T}$	$1.13 R_L + \frac{0.15}{T}$	
$3.4 \times 0.4 + \frac{0.45}{8.7} = 1.36 + 0.05 = 1.41$ ohms	$1.13 \times 0.4 + \frac{0.15}{4.6} = 0.45 + 0.03 = 0.48$ ohms	
$\frac{NP}{NT} = \frac{200}{240} = 0.833$	$\frac{40}{120} = 0.333$	
$\frac{NP V_{CL}}{100} = \frac{0.833 \times 200}{100} = 1.67$	$\frac{0.333 \times 200}{100} = 0.67$	
Yes	Yes	
Conclusion:	$T_L = 8.7$	$T_H = 4.6$
	30% Sensitivity Relay is Adequate.	

**Table 1**  
HU Relay Tap Ratios

	2.9	3.2	3.5	3.8	4.2	4.6	5.0	8.7
2.9	1.000	1.103	1.207	1.310	1.448	1.586	1.724	3.000
3.2		1.000	1.094	1.188	1.313	1.438	1.563	2.719
3.5			1.000	1.086	1.200	1.314	1.429	2.486
3.8				1.000	1.105	1.211	1.316	2.289
4.2					1.000	1.095	1.190	2.071
4.6						1.000	1.087	1.890
5.0							1.000	1.740
8.7								1.000

- Determine Mismatch for 2 winding banks:

$$\% \text{ mismatch} = 100 \frac{(I_{RL}/I_{RH}) - (T_L/T_H)}{S} \quad (1)$$

where S is the small of the two terms,  $(I_{RL}/I_{RH})$  or  $(T_L/T_H)$

- For 3 winding banks:

Repeat calculation of equation (1) and apply similar equations to calculate mismatch from the intermediate to high and from the intermediate to low voltage windings.



Where tap changing under load is performed the relays should be set on the basis of the middle or neutral tap position. The total mismatch, including the automatic tap change should not exceed 15% with a 30% sensitivity relay, and 20% with a 35% sensitivity relay. Note from Figure 60 that an ample safety margin exists at these levels of mismatch.

7. Check current transformer performance. Ratio error should not exceed 10% with maximum symmetrical external current flowing. An accurate method of determining ratio error is to use ratio-correction-factor curves (RCF). \*A less accurate, but satisfactory method is to utilize the ANSI relaying accuracy classification. If the "C" (or 10L) accuracy is used, performance will be adequate if:

$$(N_p V_{cl} - (I_{ext} - 100) R_s) / I_{ext} \text{ is greater than } Z_T$$

Note: let  $I_{ext} = 100$

when maximum external fault current is less than 100A.

For wye-connected ct:

$$Z_T = \text{lead resistance} + \text{Relay burden} + Z_A \\ = 1.13R_L + \frac{0.15}{T} + Z_A \text{ Ohms} \quad (3)$$

( $R_L$  multiplier, 1.13, is used to account for temperature rise during faults  $\frac{0.15}{T}$  is an approximation. Use two way lead resistance for single phase to ground fault.)

(2) For delta connected ct:

$$Z_T = 3 \left( 1.13R_L + \frac{0.15}{T} + Z_A \right) \text{ Ohms} \\ = 3.4R_L + \frac{0.45}{T} + 3Z_A \quad (4)$$

\*(The factor of 3 accounts for conditions existing during a fault phase.)

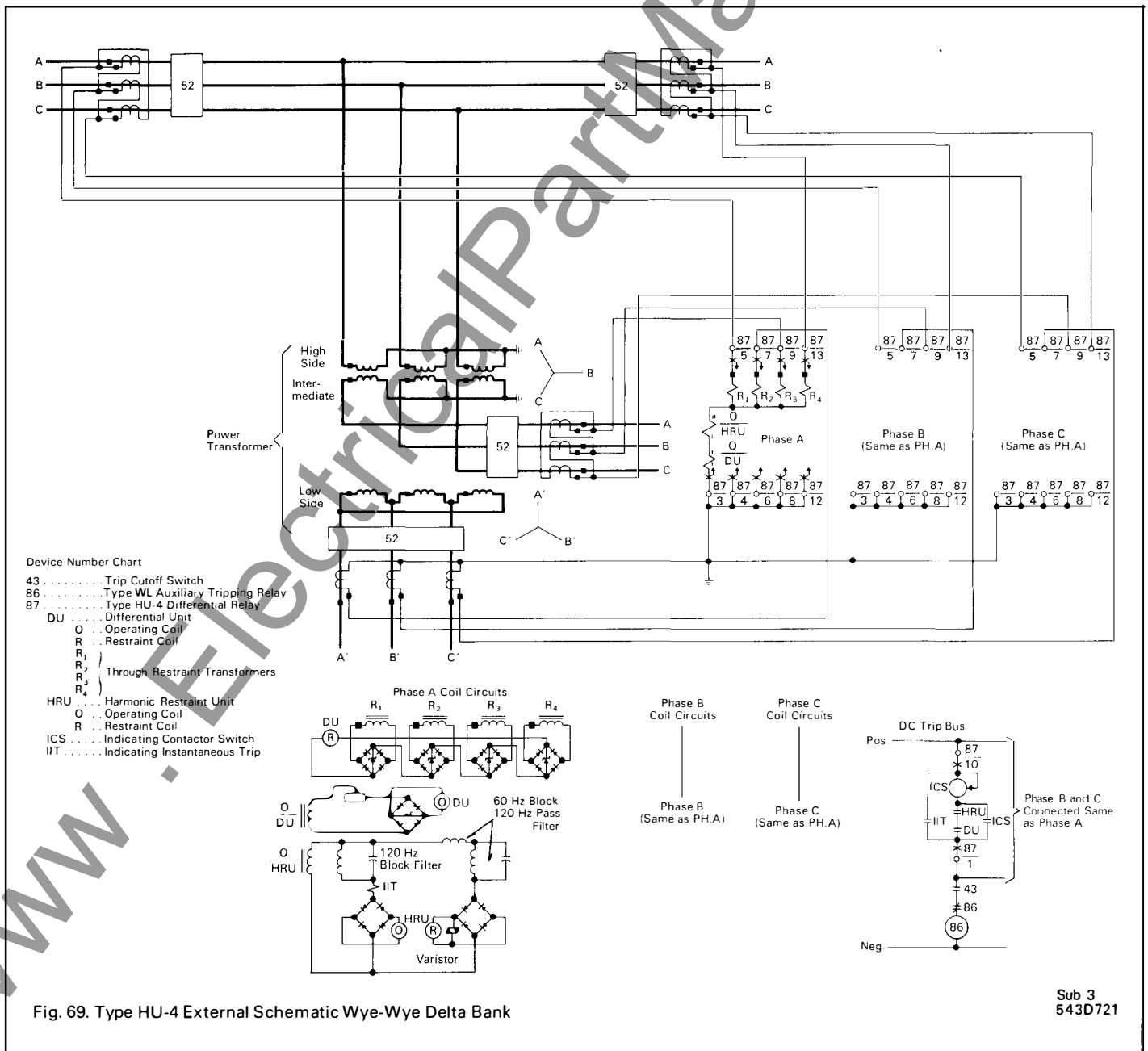
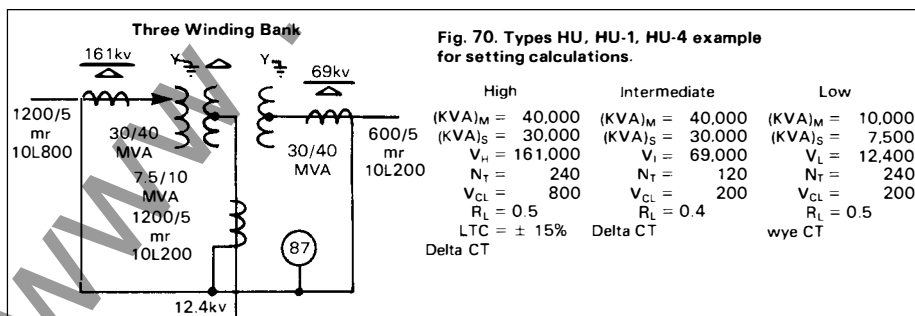

Fig. 69. Type HU-4 External Schematic Wye-Wye Delta Bank

Three-Winding Transformer Calculations (See Figure 70)	High	Intermediate	Low
<b>1. Select CT Ratio:</b>			
$I_P = \frac{(KVA)_M}{(KV) \sqrt{3}}$	$\frac{40,000}{161 \sqrt{3}} = 143 \text{ Amp.}$	$\frac{40,000}{69 \sqrt{3}} = 334 \text{ Amp.}$	$\frac{10,000}{12.4 \sqrt{3}} = 465 \text{ Amp.}$
Select Ratio	400/5 (N=80)	600/5 (N=120)	1000/5 (N=200)
<b>2. Calculate Relay Current:</b>			
$I_S = \frac{I_P}{N}$	$\frac{143}{80} = 1.79 \text{ Amp.}$	$\frac{334}{120} = 2.78 \text{ Amp.}$	$\frac{465}{200} = 2.33 \text{ Amp.}$
$I_R \text{ (At 40 MVA)} =$	$I_{RH} = 1.79 \sqrt{3} = 3.10 \text{ Amp.}$	$I_{RI} = 2.78 \sqrt{3} = 4.82 \text{ Amp.}$	$I_{RL} = \frac{40}{10} \times 2.33 = 9.32 \text{ Amp.}$
<b>3. Calculate Current Ratios:</b>			
	$\frac{I_{RI}}{I_{RH}} = \frac{4.82}{3.10} = 1.55$	$\frac{I_{RL}}{I_{RH}} = \frac{9.32}{3.10} = 3.01$	
<b>4. Select Tap Ratio From Table 1:</b>			
	$\frac{T_I}{T_H} = \frac{4.6}{2.9} = 1.586$	$\frac{T_L}{T_H} = \frac{8.7}{2.9} = 3.00$	
$I_R > \text{relay continuous rating}$	No	No	No
<b>5. Check IIT Operation:</b>			
Max. symmetrical error current > 10 times relay tap	No	No	No
<b>6. Determine Mismatch:</b>			
% Mismatch	$100 \frac{(I_{RH}/I_{RI}) - (T_H/T_I)}{T_H/T_I} = 100 \frac{(3.10/4.82) - (2.9/4.6)}{2.9/4.6} = 100 \frac{0.643 - 0.630}{0.630} = 2.1\%$	$100 \frac{(I_{RI}/I_{RL}) - (T_I/T_L)}{(I_{RI}/I_{RL})} = 100 \frac{(4.82/9.32) - (4.6/8.7)}{4.82/9.32} = 100 \frac{0.517 - 0.529}{0.517} = -2.3\%$	$100 \frac{(I_{RL}/I_{RH}) - (T_L/T_H)}{T_L/T_H} = 100 \frac{(9.32/3.10) - (8.7/2.9)}{8.7/2.9} = 100 \frac{3.01 - 3.00}{3.00} = 0.33\%$
<b>7. Check CT Performance:</b>			
$Z_T =$	$3.4 R_L + \frac{0.45}{T} = 3.4 \times 0.5 + \frac{0.45}{2.9} = 1.7 + 0.16 = 1.86 \text{ ohms}$	$3.4 R_L + \frac{0.45}{T} = 3.4 \times 0.5 + \frac{0.45}{4.6} = 1.7 + 0.10 = 1.80 \text{ ohms}$	$1.13 R_L + \frac{0.15}{T} = 1.13 \times 0.5 + \frac{0.15}{8.7} = 0.57 + 0.02 = 0.59 \text{ ohms}$
$N_P = \frac{N}{N_T} =$	$\frac{80}{240} = 0.333$	$\frac{120}{120} = 1.0$	$\frac{200}{240} = 0.833$
$\frac{(N_P V_{CL})}{100} =$	$\frac{800 \times 0.333}{100} = 2.67$	$\frac{200 \times 1.0}{100} = 2.0$	$\frac{200 \times 0.833}{100} = 1.67$
$(N_P V_{CL}/100) > Z_T$	Yes	Yes	Yes
<b>Conclusion:</b>	$T_H = 2.9$	$T_I = 4.6$	$T_L = 8.7$

Requires 35% Sensitivity Relay since  $(LTC+M) > 15\%$ .



**Further Information**

HU, HU-1: Descriptive Bulletin 41-347  
Instruction Leaflet 41-347.11

HU-4: Descriptive Bulletin 41-347

Fig. 70.



**Type HRU Harmonic Restraint Unit**

The HRU harmonic restraint relay is a high speed relay used for supervision of differential, overcurrent, or pilot relays. It is applied in various transformer differential schemes to provide security against false tripping on transformer magnetization inrush.

Magnetizing inrush current waves have various wave shapes. A typical wave appears as a rectified half wave with decaying peaks. In any case, the various wave shapes are high in harmonics, with the second harmonic predominant. Since the second harmonic is always present in magnetizing inrush waves and not in internal fault current waves, this second harmonic is used in the relay to restrain the unit on magnetizing inrush.

The relay uses two L-C filter circuits with a full wave rectifier at the output of each. The dc output of the fundamental pass circuit is fed to the operating coil, and the dc output of the second harmonic pass filter is fed to the restraining coil. The constants of these filter circuits are such that the harmonic unit will not close its contacts unless the second harmonic content is less than 15% of the fundamental component.

The 3-phase HRU relay may be added to an existing induction-disc differential relay installation should inrush tripping become a problem. See Figure 71.

Figure 74 illustrates a scheme using a 3-phase HRU relay to supervise the HCB or HCB-1 relay for the prevention of magnetizing inrush tripping.

When there are no selectivity requirements with low side protective devices a modified single phase HRU relay may provide sensitive instantaneous overcurrent protection of a transformer. See Figure 73.

**Characteristics**

3-phase, 60 Hertz, spst-cc contacts, FT-31 Flexitest case.  
One harmonic restraint unit, three instantaneous overcurrent units, one mixing transformer.

Single phase, 60 Hertz, spst-cc contacts, FT-21 Flexitest case.

One harmonic restraint unit, one instantaneous overcurrent unit.

No ratio taps (2 relay ratings, 2.0 and 4.0 amperes).

**Burden:**

2.0 ampere relay—0.88 volt-amperes at 2.0 amperes.  
50.0 volt-amperes at 16.0 amperes.

4.0 ampere relay—0.91 volt-amperes at 4.0 amperes.  
53.0 volt-amperes at 32.0 amperes.

Thermal rating: 300 amperes for 1 second.

Frequency response: see Figure 72.

**Further Information**

Production Bulletin 41-330C6.  
Instruction Leaflet 41-347.3.

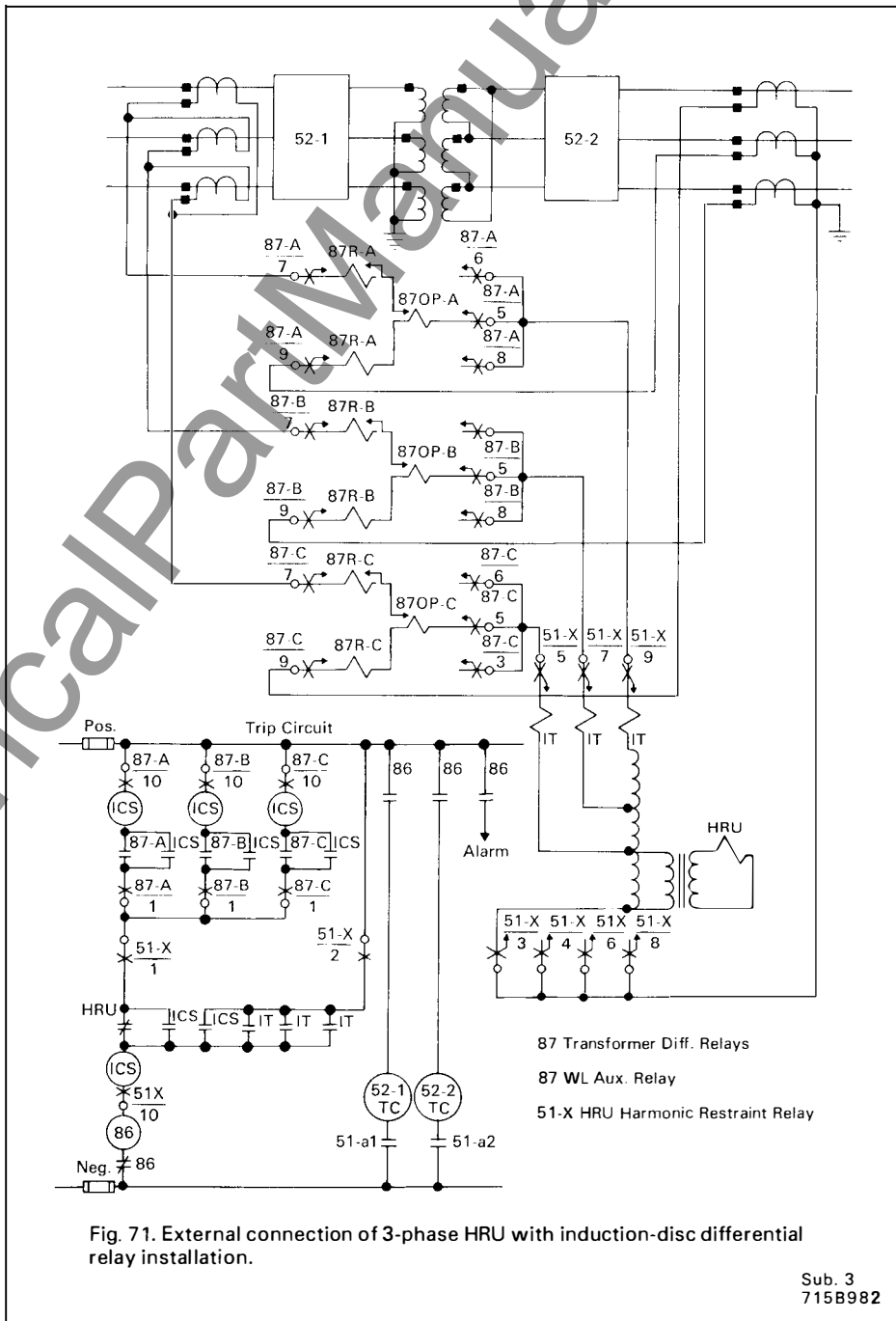

Fig. 71. External connection of 3-phase HRU with induction-disc differential relay installation.

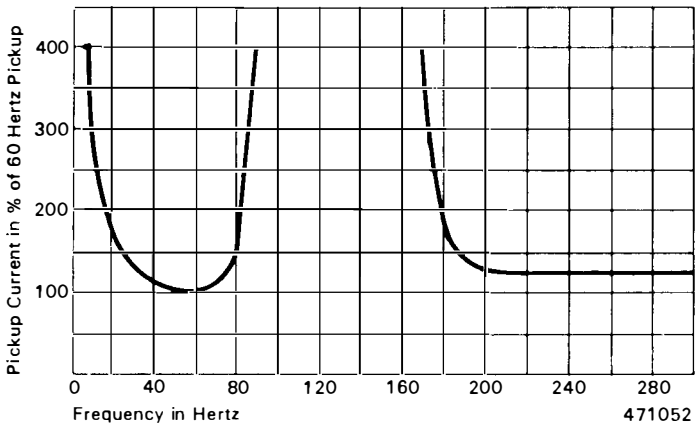

Fig. 72. HRU relay frequency response curves.

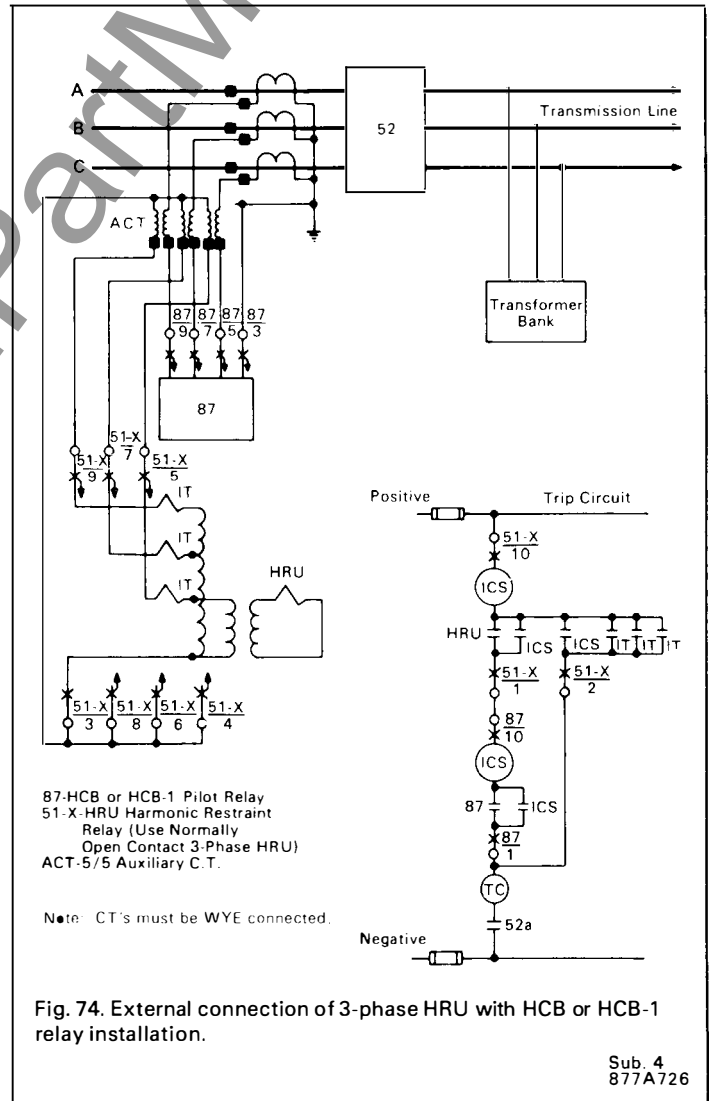
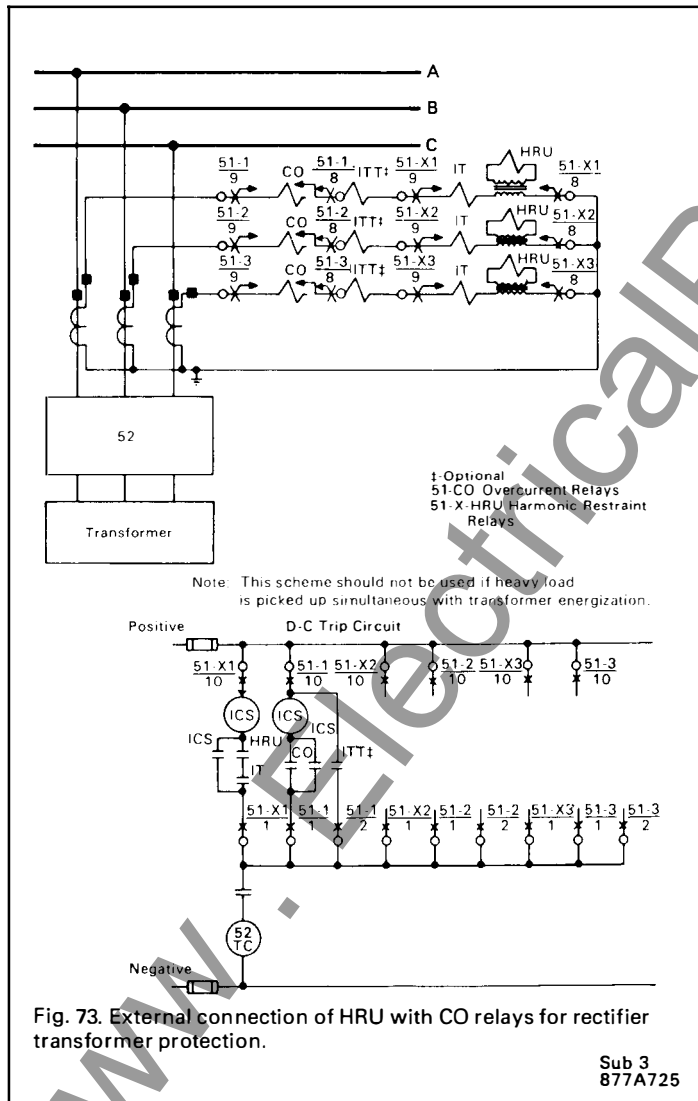

Fig. 74. External connection of 3-phase HRU with HCB or HCB-1 relay installation.