

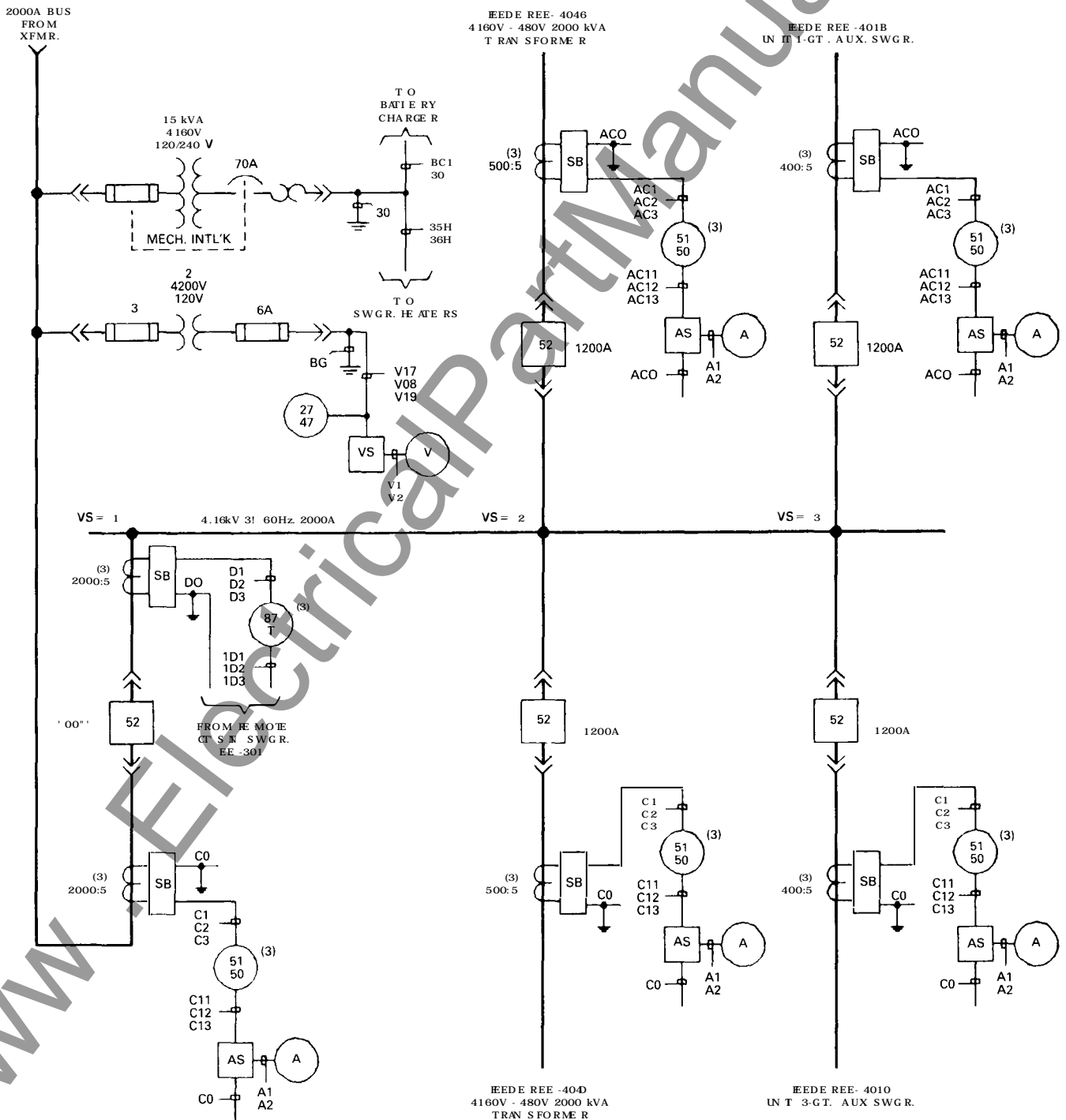

VacClad-W Medium Voltage Metal-Clad Switchgear





Type VacClad-W Medium Voltage Metal-Clad Switchgear

Table of Contents

Description, Application	2
Metal-Clad Switchgear Definition	2
Applicable Industry Standards	3
Design, Production Tests	3
Features	4
Typical Vertical Sections	6
Available Configurations	7
System Application	8
Surge Protection	14
Instrument Transformers	15
Control Equipment	16
Dimensions, Installation	19
Shipping, Receiving, Handling, Storage	20
Installation, Field Assembly	20
Weights	20
Standard Designs, Vertical Sections	21
How to Arrange, Select, Specify VacClad-W Switchgear	28
Typical Specifications	30

Description and Application

VacClad-W Metal-Clad Switchgear is an integrated assembly of drawout vacuum circuit breakers, bus, and control devices coordinated electrically and mechanically for medium voltage circuit protection. The Metal-Clad integrity provides maximum circuit separation and safety. Included are isolated grounded metal compartments, complete insulation of all conductors insuring that no live parts will be exposed by opening of a door. It is typically used on circuits involving feeder circuits, transmission lines, distribution lines and motors.

All major components are manufactured by Westinghouse, establishing one source of responsibility for the equipment and assuring high standards in quality, coordination, reliability and service.

VacClad-W Switchgear is available in voltage ratings of 4.76kV through 15kV and in nominal interrupting capacities of 250MVA (29kA), 350MVA (41kA), 500MVA (18kA and 33kA), 750MVA (28kA), 1000MVA (37kA) and for indoor or outdoor applications.

Metal-Clad Switchgear Definition

Metal-Clad Switchgear is an assembly of units characterized by the following features:

- The main interrupting device is removable and arranged with a mechanism for moving it physically between connected and disconnected positions. It is equipped with self-aligning and self-coupling primary and secondary disconnecting devices.
- The interrupting devices, buses, voltage transformers, and control power transformers, are completely enclosed by grounded metal barriers, which have no intentional openings between compartments. A metal barrier in front of the interrupting device ensures that when, in the connected position, no live parts are exposed by the opening of a door.
- All live parts are enclosed within grounded metal compartments.
- Automatic shutters cover primary circuit elements when the removable element is in the disconnected, test or removed position.
- Primary bus conductors and connections are covered with track-resistant insulating material throughout.
- Mechanical interlocks are provided to maintain a proper and safe operating sequence.
- Instruments, meters, relays, secondary control devices and their wiring are isolated, where necessary, by grounded metal barriers from all primary circuit elements.

www.ElectricalPaper.com



Type VacClad-W Medium Voltage Metal-Clad Switchgear

Applicable Industry Standards ANSI American National Standards Standard Institute

C37.010 Application guide for ac high-voltage circuit breakers rated on a symmetrical current basis

C37.100 Definitions for power switchgear

C37.04 Rating structure for ac high-voltage circuit breakers

C37.06 Preferred ratings for ac high-voltage circuit breakers rated on a symmetrical current basis

C37.07 Factors for reclosing service

C37.09 Test procedure for ac high voltage circuit breakers

C37.11 Power circuit breaker control

C37.20.2 Metal-Clad and Station-Cubicle switchgear

① C37.21 Application Guide for Metal-Enclosed Power Switchgear

① C37.55 Conformance Testing of Metal-Clad Switchgear

C37.24 Guide for evaluating the effect of solar radiation

NEMA National Electrical Manufacturers Association

SG-4 Power Circuit Breakers

SG-5 Power Switchgear Assemblies

International Electrotechnical Commission Recommendations

IEC 56 High Voltage AC Breakers

① Proposed

Design/Proof Tests

VacClad-W Metal-Clad switchgear meets applicable ANSI, IEEE, NEMA and IEC standards. The design criteria dictated that all tests demonstrate performance above the requirements of the standards. The ANSI test series is basic test criteria and includes interruption, BIL, dielectric, continuous current, mechanical life, and thermal and environmental conditions.

The design/proof testing of VacClad-W switchgear is the most extensive ever performed by Westinghouse, which has always maintained the highest standards for its Metal-Clad equipment.

Production Tests

Circuit Breaker

- Each breaker draw-out unit is checked for alignment with a master cell fixture that verifies all interfaces and interchangeability.

- All circuit breakers are operated over the range of minimum to maximum control voltage.

- Interrupter contact gap is factory set.

- One-minute dielectric test is performed on each breaker, per ANSI Standards.

- Final inspection and quality check.

Housing

- Master breaker fixture is inserted into each breaker cell to ensure alignment.

- One-minute dielectric test per ANSI Standards is applied to both primary and secondary circuits.

- Operation of wiring, relays, and other devices is verified by test.

- Final inspection and quality check.



Type VacClad-W Medium Voltage Metal-Clad Switchgear

Features

1. **Vacuum Interrupter Current Transfer Conductor**
The Westinghouse "Stiff-Flexible" design eliminates the need for a main conductor sliding contact and its costly maintenance.
2. **Breaker Rails**
The breaker and auxiliaries can be withdrawn on rails for inspection and maintenance without the need for a separate lifting device.
3. **Front Breaker Mechanism**
The stored energy mechanism is on the front of the breaker so the inspection or maintenance can be done with the breaker on its rails.
4. **Horizontal Drawout Circuit Breaker**
Type VCP-W breaker is a horizontal drawout design, which provides connect, test, and disconnect position.
5. **Automatic Shutters**
These steel shutters operate automatically when the circuit breaker is withdrawn, to protect workmen from accidental contact with the stationary primary contacts.
6. **Main Bus System**
The main bus has fluidized-bed, track-resistant epoxy insulation with plated joints and constant pressure washers.
7. **Current Transformers**
There is space for up to four current transformers per phase which are easily accessible from the front.
8. **Primary and Secondary Contacts**
All moving breaker contacts are self-aligning, have positive action, and are silver-plated.
9. **Metal Compartment Barriers**
All compartments are enclosed by grounded metal barriers.
10. **Barriers**
Barriers are breaker mounted.
11. **Breaker Wheels**
Breaker can be rolled on floor when removed from the structure.
12. **Auxiliary Compartment Shutter**
This shutter operates automatically when the auxiliary drawer is withdrawn to protect workmen from accidental contact with the stationary primary contacts.

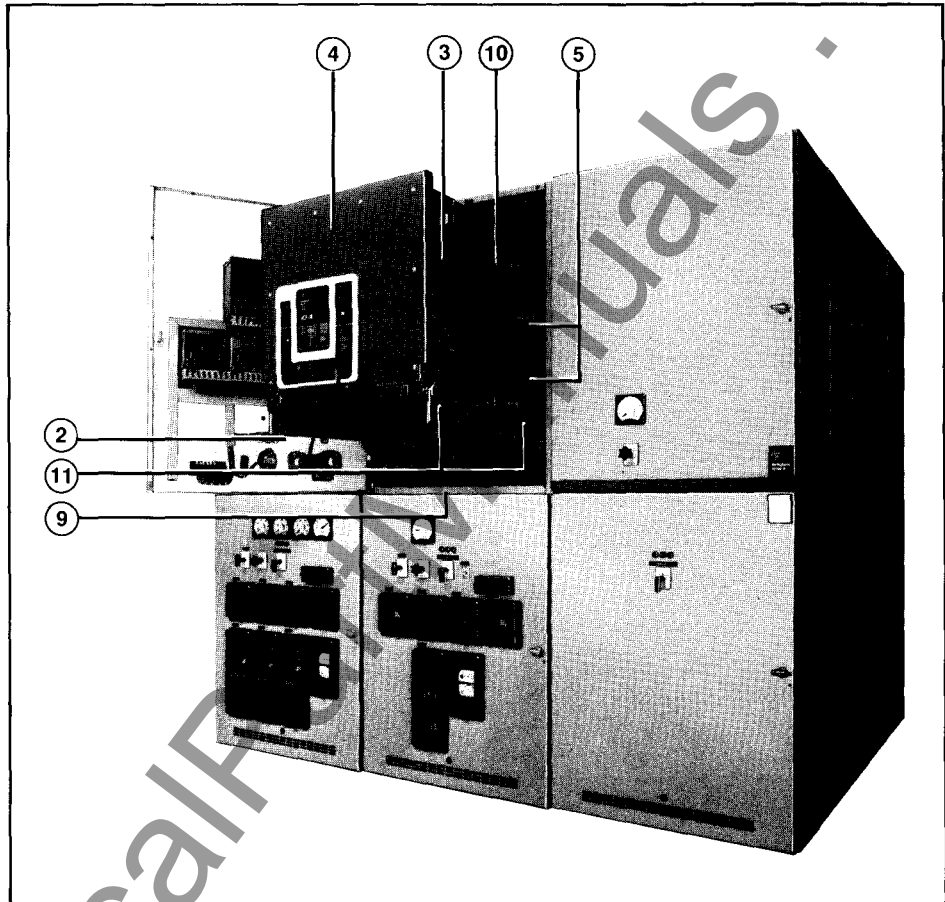



Type VacClad-W Medium Voltage Metal-Clad Switchgear

Features, Continued

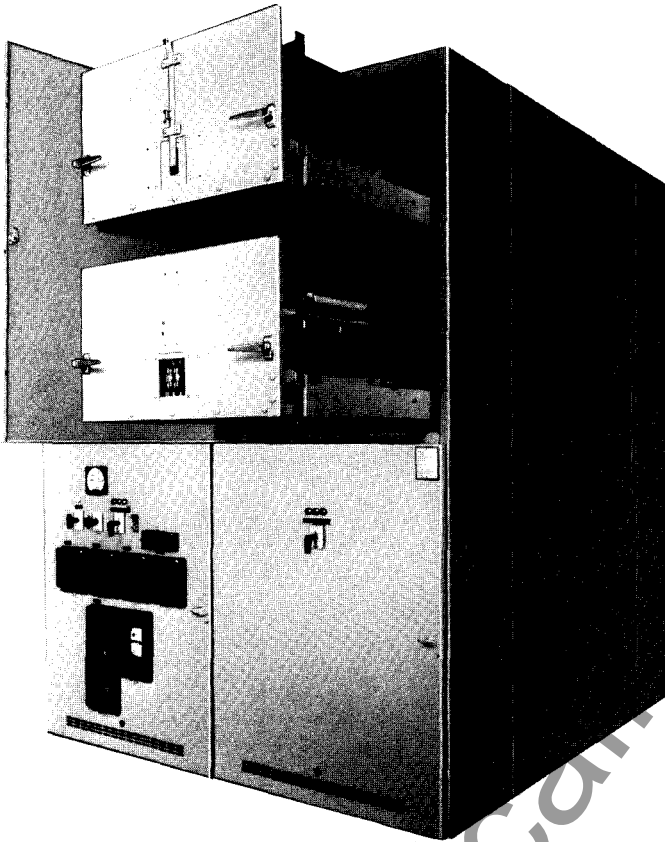

Front view showing auxiliary compartments withdrawn.



Rear view showing cable compartments.

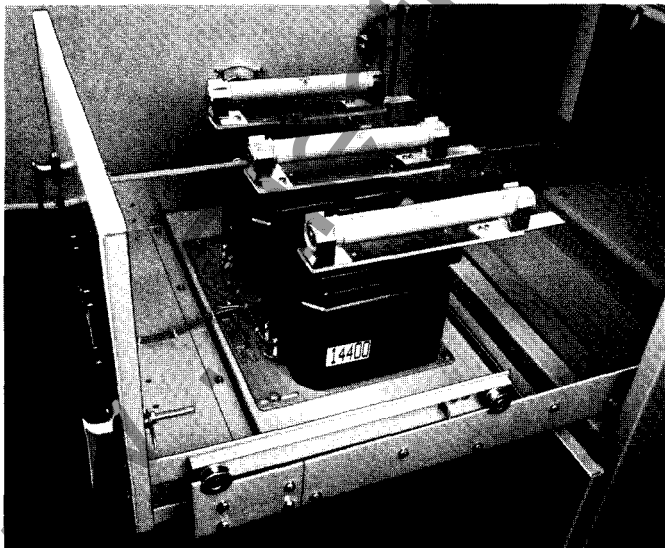

View of drawout voltage transformers.

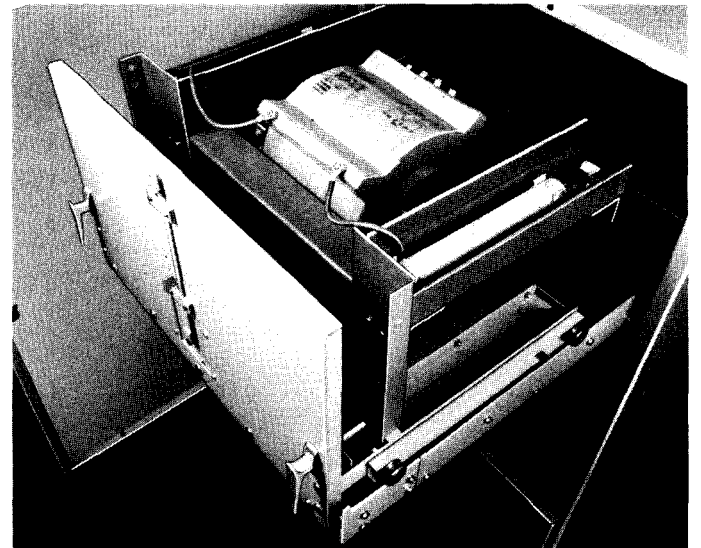

View of drawout control power transformer.



Type VacClad-W Medium Voltage Metal-Clad Switchgear

Typical Vertical Sections

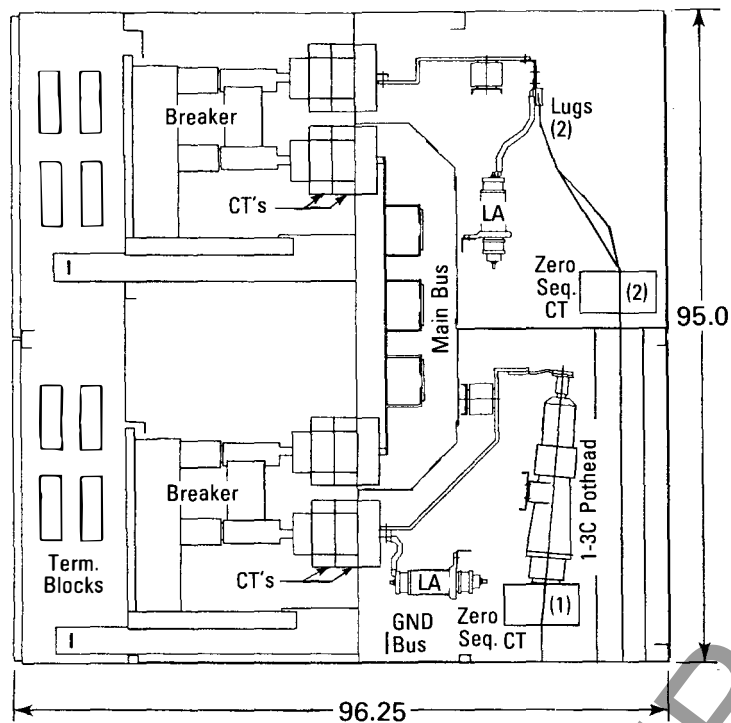

Fig. A 36 In. Wide Typical Breaker/Breaker Vertical Section

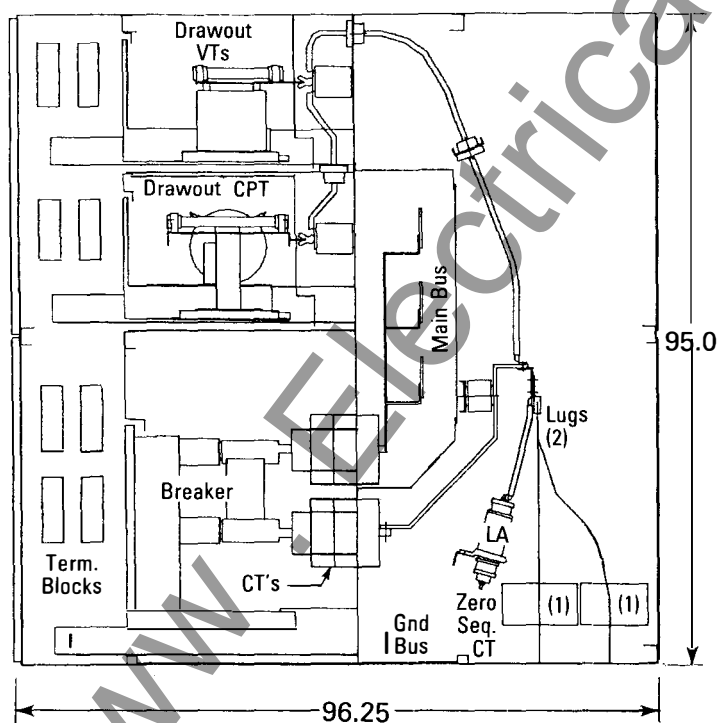

Fig. B 36 In. Wide Typical Auxiliary/Breaker Vertical Section

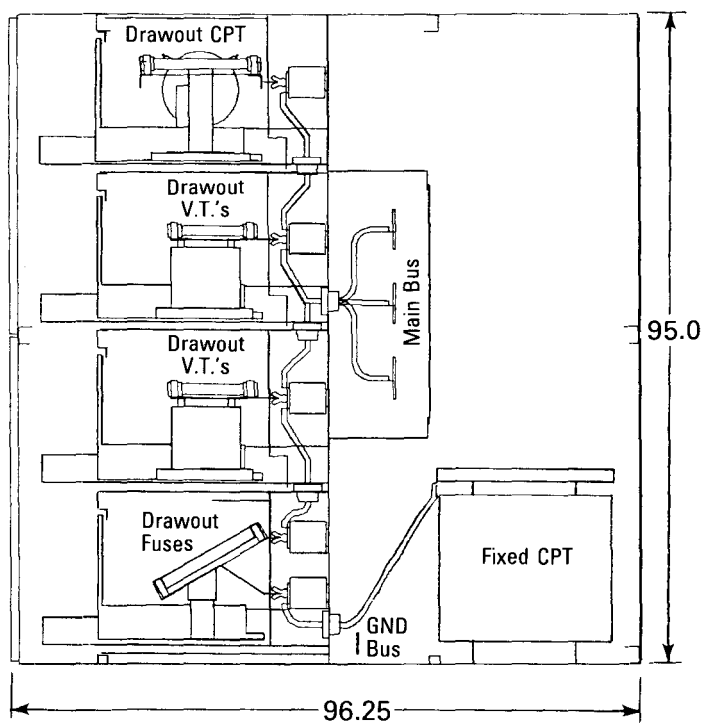

Fig. C 36 In. Wide Typical Auxiliary/Auxiliary Vertical Section



Type VacClad-W Medium Voltage Metal-Clad Switchgear

Available Configurations

1200A Breaker	1200A Breaker	1200A Breaker	D.O. Auxiliary	2000A Breaker
1200A Breaker	2000A Breaker	D.O. Auxiliary	1200A Breaker	D.O. Auxiliary
D.O. Auxiliary	Vented Auxiliary Compt. (Non-D.O.)	D.O. Auxiliary	2000A Breaker	3000A Breaker
2000A Breaker	3000A Breaker	D.O. Auxiliary	1200A Breaker	Blank Space
				Line Conn. D.O. Auxiliary



Type VacClad-W Medium Voltage Metal-Clad Switchgear

Application

Table 1: Available VCP-W Vacuum Circuit Breaker Types Rated on Symmetrical Current Rating Basis, per ANSI Standards

Identification Circuit Breaker Type	Nominal Voltage Class kV Class	Nominal 3-Phase MVA Class	Rated Values				Rated Withstand Test Voltage kV rms	Insulation Level kV Crest	Current		Rated Interrupting Time Cycles	Rated Permissible Tripping Delay Sec.	Rated Max. Voltage Divided By K V/K	Related Required Capabilities®			
			Voltage Rated Max. Voltage kV rms	Rated Voltage Range Factor K	Rated Continuous Current at 60 Hz Amperes	Rated Short Circuit Current (at rated Max.) kA rms			Maximum Sym. Interrupting Capability kA rms	3 Sec. Short-Time Carrying Capability kA rms				Closing and Latching Capability (Momentary) kA rms	2.7 K Times Rated Short-Circuit Current kA Crest		
																Low Frequency	Impulse
50 VCP-W 250	4.16	250	4.76	1.24	19	60	1200 2000 3000	29	5	2	3.85	36	36	58 78G	97 132G		
50 VCP-W 350	4.16	350	4.76	1.19	19	60	1200 2000 3000	41	5	2	4.0	49	49	78	132		
75 VCP-W 500	7.2	500	8.25	1.25	36	95	1200 2000 3000	33	5	2	6.6	41	41	66	111		
150 VCP-W 500	13.8	500	15	1.30	36	95	1200 2000 3000	18	5	2	11.5	23	23	37 58G	62 97G		
150 VCP-W 750	13.8	750	15	1.30	36	95	1200 2000 3000	28	5	2	11.5	36	36	58 77G	97 130G		
150 VCP-W 1000	13.8	1000	15	1.30	36	95	1200 2000 3000	37	5	2	11.5	48	48	77	130		

Table 2: Available VCP-W Vacuum Circuit Breaker Types Rated on Symmetrical Current Rating Basis per IEC Standards

Circuit Breaker Type	Voltage u kV rms	Withstand Voltages		Normal Current In A	Short Circuit Breaking Current, Isc kAG	Short-Time (3 Sec.) Withstand Current kAG	Short Circuit Making Current (Peak) 2.5 x Isc kA Crest
		1 Min. Power Frequency kV rms	Lightning Impulse kV Crest				
		10t	40t				
36 VCP-W 25	3.6	10t	40t	630 1250 2000	25	25	63
36 VCP-W 32	3.6	10t	40t	1250 2000	31.5	31.5	79
36 VCP-W 40	3.6	10t	40t	1250 2000	40	40	100
72 VCP-W 25	7.2	20t	60t	630 1250 2000	25	25	63
72 VCP-W 32	7.2	20t	60t	1250 2000	31.5	31.5	79
72 VCP-W 40	7.2	20t	60t	1250 2000	40	40	100
120 VCP-W 25	12	28t	75t	630 1250 2000	25	25	63
120 VCP-W 32	12	28t	75t	1250 2000	31.5	31.5	79
120 VCP-W 40	12	28t	75t	1250 2000	40	40	100
175 VCP-W 25	17.5	38	95	630 1250 2000	25	25	63
175 VCP-W 32	17.5	38	95	1250 2000	31.5	31.5	79
175 VCP-W 40	17.5	38	95	1250 2000	40	40	100

Table 2 Notes

† Withstand voltage capabilities exceed these values. Contact your local representative if you require higher values.
 ① In the E C rating Structure per E C 56 and E C 694, there is no "Voltage range factor" K". Therefore, the 175 VCP-W 25 is rated at 25 kA at 17.5 kV, and also 25 kA at

13.2 kV. There is no increase in short circuit current rating to go along with the lower applied voltage level.
 ② The rated operating sequence is 0-3m-CO-3m-CO. However, these breaker ratings are also available for rapid auto-reclosing service with the 0-0.3s-CO-3m-CO operating sequence.

Table 1 Notes

① Non-Standard Breakers with High Momentary Rating available for Special Applications.
 ② For 3 phase and line to line faults, the sym interrupting capability at an operating voltage, V0

$$= \frac{V}{V_0} \text{ (Rated Short-Circuit Current)}$$

But not to exceed KI.
 Single line to ground fault capability at an operating voltage, V0

$$= 1.15 \frac{V}{V_0} \text{ (Rated Short-Circuit Current)}$$

But not to exceed KI.
 The above apply on predominately inductive or resistive 3-phase circuits with normal frequency line to line recovery voltage equal to the operating voltage.
 ③ For Reclosing Service, the Sym. Interrupting Capability and other related capabilities are modified by the reclosing capability factor obtained from the following formula:

$$R (\%) = 100 - \frac{C}{6} \left[\ln \left(2I_1 + \frac{15 \cdot T_1}{15} + \frac{15 \cdot T_2}{15} + \dots \right) \right]$$

 Where C = kA Sym. Interrupting Capability at the Operating Voltage but not less than 18.
 n = Total No. of Openings.
 T1, T2 etc. = Time interval in seconds except use 15 for time intervals longer than 15 sec.

Note: Reclosing Service with the standard duty cycle 0 + 15s + CO does not require breaker capabilities modified since the reclosing capability factor R = 100%.

④ Tripping may be delayed beyond the rated permissible tripping delay at lower values of current in accordance with the following formula:

$$T \text{ (seconds)} = Y \left[\frac{KI \text{ (K Times Rated Short-Circuit Current)}}{\text{Short-Circuit Current Through Breaker}} \right]^2$$

The aggregate tripping delay on all operations within any 30 minute period must not exceed the time obtained from the above formula.

⑤ Included for reference only.

⑥ Preferred rating.



Type VacClad-W Medium Voltage Metal-Clad Switchgear

Application Quick Check Table

For application of circuit breakers in a radial system supplied from a single source transformer. Short-circuit duty was determined using E/X amperes and 1.0 multiplying factor for X/R ratio of 15 or less and 1.25 multiplying factor for X/R ratios in the range of 15 to 40.

Applications Above 3300 Feet

The rated one-minute power frequency withstand voltage, the impulse withstand voltage, the continuous current rating, and the maximum voltage rating must be multiplied by the appropriate correction factors below to obtain modified ratings which most equal or exceed the application requirements. Note that intermediate values may be obtained by interpolation.

Source Transformer MVA Rating		Operating Voltage kV					Altitude (feet)	Correction Factor	
Motor Load 100%	Motor Load 0%	2.4	4.16	6.6	12	13.8		Current	Voltage
1	1.5	50 VCP-W 250 12 kA	50 VCP-W 250 10.1 kA	150 VCP-W 500 23 kA	150 VCP-W 500 22.5 kA	150 VCP-W 500 19.6 kA	3,300 (and below)	1.00	1.00
1.5	2						5,000	0.99	0.95
2	2.5	50 VCP-W 250 36 kA	50 VCP-W 250 33.2 kA	75 VCP-W 500 41.3 kA	150 VCP-W 750 35 kA	150 VCP-W 750 30.4 kA	10,000	0.96	0.80
2.5	3						3,750		
3	3.75	50 VCP-W 350 49 kA	50 VCP-W 350 46.9 kA	150 VCP-W 1000 46.3 kA	150 VCP-W 1000 40.2 kA				
3.75	5						5		
5	7.5	Breaker Type and Sym. Interrupting Capacity at the Operating Voltage							
7.5	10						10		
10	10								
10	12						12		
12	15								
15	20						15		
20	20								
20	25						20		
20	30								
20	50						20		

① Transformer Impedance 6.5% or more, all other Transformer Impedances are 5.5% or more.

Load Current Switching

The following table of number of operations is a guide to normal maintenance for circuit breakers operated under usual service conditions for most repetitive duty applications including isolated capacitor bank switching and shunt reactor switching, but not for arc furnace switching. The numbers in the Table are consistent with ANSI C37.06 (1979).

Circuit Breaker Type	Continuous Current Rating Amperes	Number of Operations			
		Max. No. Operations Between Servicing	No Load Mechanical Duty	Continuous Current Switching	Inrush Current Switching
All VCP-W Vacuum Circuit Breakers	1200	2000	10,000	1000	750
	2000	2000	10,000	1000	750
	3000	1000	5,000	500	400

Servicing shall consist of adjusting, cleaning, lubricating, tightening, etc., as recommended by the circuit breaker instruction book.

Continuous current switching assumes opening and closing rated continuous current at rated maximum voltage with power factor between 80% leading and 80% lagging.

Inrush current switching assures a closing current equal to 600% of rated continuous current at rated maximum voltage with power factor of 30% lagging or less, and an opening current equal to rated continuous current at rated maximum voltage with power factor between 80% leading and 80% lagging.

In accordance with ANSI C37.06(1979), if a short-circuit operation occurs before the completion of the listed switching operations, maintenance is recommended and possible functional part replacement may be necessary, depending on previous accumulated duty, fault magnitude, and expected future operations.



Type VacClad-W Medium Voltage Metal-Clad Switchgear

Application on Symmetrical Current Rating Basis

Application Considerations

Westinghouse medium voltage metal-clad switchgear provides control and protection for generators, motors, transformers and all types of feeder circuits. In the usual application, the selection of the circuit breaker for the operating voltage, to carry the load current, and provide for the interruption of the available short-circuit, is of primary importance. The purpose of this application data is to aid in this selection.

It should be noted that for a particular application there may be other items of technical importance that require careful consideration. Also, requirements for special applications or unusual service conditions should be referred to the nearest Westinghouse Sales Office with details and a request for recommendations.

Rated Maximum Voltage

The line to line operating voltage, V_o , should not exceed the rated maximum line to line voltage, V , in Table 1, since this is the upper limit for operation.

Rated Continuous Current

The continuous current rating of a circuit breaker is a maximum rating. The circuit breaker rating should always be in excess of the utilization equipment rating to provide for short time overload capability.

Transformer main breakers should be rated in excess of 125% of transformer full load amperes. Always consider forced cooled rating, possible future forced cooling and 12% additional capacity for 65° C rise rating when used.

Induction motor and synchronous motor starting breakers should be rated in excess of 125% of motor full load amperes.

Generator breakers should be in excess of 125% of generator full load current. Other factors such as increased capacity at 1.0 power factor, reduced voltage or low ambient temperature rating may have to be considered.

Capacitor bank feeder breakers should have a rating in excess of 135% of the bank full load current. This is due to a 0 to +15% manufacturing tolerance in capacitors, kVAR due to harmonic currents and possibility of up to 10% over-voltage.

Breaker Capacitor Switching Limits

Continuous Current Rating	Grounded Capacitor Bank	Ungrounded Capacitor Bank
1200A	890A	960A
2000A & 3000A	1180A	1280A

Low Current Interruption

The VCP-W circuit breaker has been tested successfully for the interruption of the following low current inductive circuits up to 15 kV.

24 A, 60 A, 200 A, 600 A, 1200 A, 2000 A, and 3000 A. Each test was run at both 20%

and 80% power factors. Each test consisted of at least one Open and one Close-Open operation.

Interrupting Capability

Table 1 lists rated short-circuit current at rated voltage for the various available circuit breaker types. This is adjusted for the operating voltage to obtain the 3 phase symmetrical interrupting capability. This value is multiplied by 1.15 to obtain the single line to ground capability. Note that the 3 phase or single line to ground capabilities may not exceed KI, the maximum symmetrical interrupting capability.

Although these capabilities are expressed in sym. kilo-amperes, the circuit breaker shall be able to interrupt all values of asymmetrical as well as symmetrical short-circuit from a system having an X/R ratio of 15 or less.

Short-Circuit Duty

To check the breaker application from an interrupting standpoint, compare the interrupting capability at the operating voltage with the short-circuit duty determined for the point of application in the power system.

Table 2 lists multiplying factors depending upon the system X/R ratio, and the breaker rated interrupting time, to obtain the maximum short-circuit duty. If the maximum multiplying factor for the source of short-circuit current is used, it is not necessary to calculate the system X/R ratio. If the system X/R ratio is 15 or less, the multiplying factor is 1.0.

Short-Circuit Duty = E/X amperes (Max. Mult. Factor)

A closer check of the application requires calculation of the system X/R ratio. It is sufficiently accurate (on the conservative side) to neglect the resistance component when calculating the system reactance, X , and neglect the reactance component when calculating the system resistance, R . Use actual equipment data for important electrical devices wherever possible.

Typical data for various system components is included in Table 3 for estimating purposes.

System X/R ratio = $\frac{X_1}{R_1}$ for 3 phase faults

and = $\frac{2X_1 + X_0}{2R_1 + R_0}$ for single line to ground

faults, where X_1 and X_0 are positive and zero sequence reactances, R_1 and R_0 are positive and zero sequence resistances.

System X/R ratio so determined is used to obtain the E/X ampere multiplying factor from Table 2.

Short-Circuit Duty = E/X amperes (Mult. Factor Table 2).

E/X Amperes Calculations

Short circuit calculations usually consist of simple E/X computations:

$$I_{3\phi} = \frac{E}{X} \quad \text{single line to ground fault} \quad I_{LG} = \frac{3E}{2X_1 + X_0}$$

Where E is the highest typical line to neutral operating voltage, and reactances are ohms, per phase, line to neutral.

Computations are simplified by selection of a common base and using the per unit system of calculations:

$$I_{3\phi} = \frac{I_B}{X} \quad \text{single line to ground fault} \quad I_{LG} = \frac{3 I_B}{2X_1 + X_0}$$

Where I_B is the base current in kilo-amperes and reactances are in per unit of the common base. Convenient per-unit system formulas:

$$I_B = \frac{\text{MVA Base}}{\sqrt{3} \text{ KV}} \quad \text{Base ohms} = \frac{\text{KV}^2}{\text{MVA}}$$

Where: KV = Line-to-Line Voltage

$$\text{per unit } X = \frac{X}{\text{MVA}} \text{ MVA base} \\ \text{or} = \frac{X}{I_B}$$

$$\text{or} = \frac{X \text{ ohms}}{\text{base ohms}} \quad \text{or} = \frac{X \text{ percent}}{100}$$

Where system is impedance grounded to limit the single line to ground fault to the 3 phase fault value or lower, only the 3 phase fault calculations are necessary.

Table 3 lists reactances quantity to be used for X for the various system components. Use actual data for important electrical devices wherever possible. Table 4 lists typical X/R ratio ranges and is included for estimating purposes.

The E/X amperes determined are in rms symmetrical kilo-ampere.

Momentary Duty

When there is motor contribution to the total short circuit, an additional calculation should be made to determine the momentary duty using the reactance quantities for momentary duty from Table 3.

Momentary Duty = 1.6 E/X Amperes

Compare momentary duty with close and latch capability or momentary rating listed in Table 1.



Type VacClad-W Medium Voltage Metal-Clad Switchgear

Table 2: Multiplying Factor for E/X Amperes (ANSI C37.010, 1979, Figs. 8, 9, 10)

System X/R	Type VCP-W Vacuum Circuit Breaker Rated Interrupting Time, 5 Cycle		
	Type of Fault		
	3 ϕ	LG	3 ϕ & LG
Ratio	Source of Short Circuit		
	Local	Remote	
1	1.00	1.00	1.00
15 ^②	1.00	1.00	1.00
20	1.00	1.02	1.05
25	1.00	1.06	1.10
30	1.04	1.10	1.13
35	1.06	1.14	1.17
40	1.08	1.16	1.22
45	1.12	1.19	1.25
50	1.13	1.22	1.27
55	1.14	1.25	1.30
60	1.16	1.26	1.32
65	1.17	1.28	1.33
70	1.19	1.29	1.35
75	1.20	1.30	1.36
80	1.21	1.31	1.37
85			1.38
90	1.22	1.32	1.39
95			1.40
100	1.23	1.33	1.41
110	1.24	1.34	1.42
120	1.24	1.35	1.43
130	1.24	1.35	1.43

- Not necessary to calculate the system X/R ratio when Max. Multiplying Factor is used.
- ② Where system X/R ratio is 15 or less, the Multiplying Factor is 1.0.

Table 4: Typical System X/R Ratio Range (for estimating purposes)

Type of circuit	X/R Range
Remote generation thru other types of circuits such as transformers rated 10 MVA or smaller for each three phase bank, transmission lines, distribution feeders, etc.	15 or less
Remote generation connected thru transformers rated 10 MVA to 100 MVA for each three-phase bank, where the transformers provide 90 percent or more of the total equivalent impedance to the fault point.	15-40
Remote generation connected thru transformers rated 100 MVA or larger for each three-phase bank where the transformers provide 90 percent or more of the total equivalent impedance to the fault point.	30-50
Synchronous machines connected thru transformers rated 25 to 100 MVA for each three-phase bank.	30-50
Synchronous machines connected thru transformers rated 100 MVA and larger.	40-60
Synchronous machines connected directly to the bus or thru reactors.	40-120

Source of Short Circuit

Local

Application of breakers at generator voltage is local source. Also, local sources are considered to be where short circuit is fed predominantly from generators through:

- a) Not more than one transformation, or
- b) a per-unit reactance external to the generator which is less than 1.5 times the generator per-unit subtransient reactance on a common system MVA base.

- ① Max. Multiplying Factor
1.25 3 ϕ Fault
1.43 LG Fault

Remote

Most applications including station service auxiliaries are remote source. Remote sources are considered to be where the short circuit is fed predominantly from generators through:

- a) two or more transformations, or
- b) a per-unit reactance external to the generator that is equal to or exceeds 1.5 times the generator per-unit subtransient reactance on a common system MVA base.

- ① Max. Multiplying Factor
1.43 3 ϕ or LG Fault

Table 3: Reactance X for E/X Amperes

System Component	Reactance X Used for		Typical Values & Range on Component Base	
	Short-Circuit Duty	Momentary Duty	% Reactance	X/R Ratio
2 Pole Turbo Generator	X	X	9	80
4 Pole Turbo Generator	X	X	7-14	40-120
			14	80
Hydro Gen. with Damper Wdgs. and Syn. Condensers	X	X	12-17	40-120
			20	30
Hydro Gen. without Damper Windings	75X	75X	13-32	10-60
			30	30
All Synchronous Motors	1.5X	1.0X	20-50	10-60
			24	30
Ind. Motors above 1000 HP, 1800 RPM and above 250 HP, 3600 RPM	1.5X	1.0X	13-35	10-60
			25	30
All Other Induction Motors 50 HP and Above	3.0X	1.2X	15-25	15-40
			25	15
Ind. Motors Below 50 HP and all Single Phase Motors	Neglect	Neglect	15-25	5-20
			25	15
Distribution System from Remote Transformers	X	X	as Specified or Calculated	15
Current Limiting Reactors	X	X	as Specified or Calculated	80
Transformers OA to 10 MVA, 69 kV	X	X	40-120	
			10	
OA to 10 MVA, above 69 kV	X	X	5.5	10
			5-7	6-12
FOA 12 to 30 MVA	X	X	7-11	12
			7-11	8-15
FOA 40 to 100 MVA	X	X	10	20
			8-24	10-30
			15	30
			8-35	20-40

Use transient reactance X'd for X for hydro generator without damper windings. For other machines use subtransient reactance X''d for X. For other system components use positive sequence reactance X¹ for X.



Type VacClad-W Medium Voltage Metal-Clad Switchgear

Application on Symmetrical Current Rating Basis

Example 1 — Fault Calculations

Type Breaker	V Max.	3 ϕ Sym. Interrupting Capability			Close & Latch or Momentary
		@ V. Max.	Max. KI	@ 4.16 kV Oper. Voltage	
50VCP-W250	4.76 kV	29 kA	36 kA	$\left[\begin{matrix} 4.76 \\ 4.16 \end{matrix} \right] (29) = 33.2 \text{ kA} \textcircled{2}$	58 kA $\textcircled{1}$
LG sym. Interrupting Capability					
		36 kA	1.15 (33.2) = 38.2 kA $\textcircled{3}$		

Note: Interrupting capabilities $\textcircled{2}$ and $\textcircled{3}$ at operating voltage must not exceed max. sym. interrupting capability KI

Check capabilities $\textcircled{1}$, $\textcircled{2}$ and $\textcircled{3}$ on the following utility system where there is no motor contribution to short circuit.

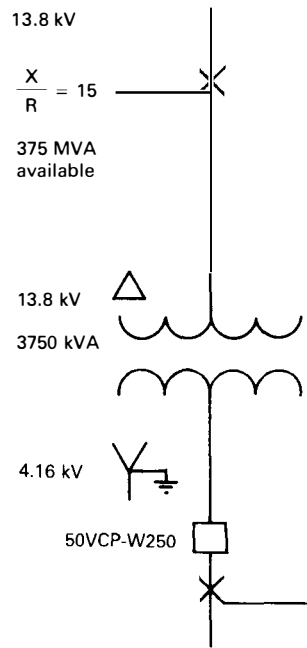

On 13.8 kV System, 3.75 MVA Base

$$Z = \frac{3.75 \text{ MVA}}{375 \text{ MVA}} = .01 \text{ pu or } 1\%$$

$$Z^2 = X^2 + R^2 = R^2 \left(\frac{X^2}{R^2} + 1 \right)$$

$$R = \frac{Z}{\sqrt{\frac{X^2}{R^2} + 1}} = \frac{1}{\sqrt{226}} = \frac{1}{15.03} = .066\%$$

$$X = \frac{X}{R} (R) = 15 (.066) = .99\%$$

Transformer Standard 5.5% Impedance has a $\pm 7.5\%$ Manufacturing Tolerance

$$\text{Transformer } Z = \frac{5.50 \text{ Standard Impedance} \times .41 (-7.5\% \text{ Tolerance})}{5.09\%}$$

From transformer losses R is calculated

$$R = \frac{24.2 \text{ kW}}{3750 \text{ kVA}} = .0065 \text{ pu or } .65\%$$

31,000 Watts Full Load
-6,800 Watts No Load
24,200 Watts Load Losses

$$\text{transformer } X = \sqrt{Z^2 - R^2} = \sqrt{(5.09)^2 - (.65)^2} = \sqrt{25.91 - .42} = \sqrt{25.49}$$

$$X = 5.05\%$$

	X	R	X/R
13.8 kV System	.99%	.066%	15
Transformer	5.05	.65	8
System Total or	6.04% .0604 pu	.716% .00716 pu	9

For 3 Phase Fault

$$I_{3\phi} = \frac{E}{X} \text{ where } X \text{ is ohms per phase and } E$$

is the highest typical line to neutral operating voltage

$$\text{or } I_{3\phi} = \frac{I_B}{X} \text{ where } X \text{ is per unit reactance}$$

I_B is base current

$$\text{Base current } I_B = \frac{3.75 \text{ MVA}}{\sqrt{3} (4.16 \text{ kV})} = .52 \text{ kA}$$

$$I_{3\phi} = \frac{I_B}{X} = \frac{.52}{.0604} = 8.6 \text{ kA Sym.}$$

System $\frac{X}{R} = 9$ (is less than 15) would use

1.0 mult. factor for short-circuit duty, therefore, short-circuit duty is 8.6 kA sym. for 3 ϕ fault $\textcircled{2}$ and momentary duty is $8.6 \times 1.6 = 13.7 \text{ kA} \textcircled{1}$

For Line to Ground Fault

$$I_{LG} = \frac{3E}{2X_1 + X_0} \text{ or } = \frac{3I_B}{2X_1 + X_0}$$

For this system, X_0 is the zero sequence reactance of the transformer which is equal to the transformer positive sequence reactance and X_1 is the positive sequence reactance of the system.

Therefore,

$$I_{LG} = \frac{3(.52)}{2(.0604) + .0505} = 9.1 \text{ kA Sym.}$$

Using 1.0 mult. factor, short-circuit duty = 9.1 kA Sym. LG $\textcircled{3}$

The 50VCP-W250 breaker capabilities exceed the duty requirements and may be applied.

With this application, short cuts could have been taken for a quicker check of the application. If we assume unlimited short circuit available at 13.8 kV and that Trans. $Z = X$

$$\text{Then } I_{3\phi} = \frac{I_B}{X} = \frac{.52}{.055} = 9.5 \text{ kA Sym.}$$

X/R ratio 15 or less mult. factor is 1.0 for short-circuit duty.

The short-circuit duty is then 9.5 kA Sym. $\textcircled{2}$, $\textcircled{3}$ and momentary duty is $9.5 \times 1.6 \text{ kA} = 15.2 \text{ kA} \textcircled{1}$.



Type VacClad-W Medium Voltage Metal-Clad Switchgear

Example 2 — Fault Calculations

All calculations on per unit basis. 7.5 MVA Base

$$\text{Base Current } I_b = \frac{7.5 \text{ MVA}}{\sqrt{3} \cdot 6.9 \text{ kV}} = .628 \text{ kA}$$

	X	R	X/R
13.8 kV System			
$X = \frac{.628 (6.9)}{21 (13.8)} = .015$.015	.001	15
Transformer	.055	.0055	10
Total Source Transf.	.070 pu	.0065 pu	11

3000 Hp Syn. motor

$$X = .20 \frac{(.628)}{.197} = .638 \text{ pu at 7.5 MVA base}$$

2500 Hp Ind. Motor

$$X = .25 \frac{(.628)}{(.173)} = .908 \text{ pu at 7.5 MVA base}$$

$$I_{3\phi} = \frac{E}{X} \text{ or } = \frac{I_b}{X} \text{ where X on per unit base}$$

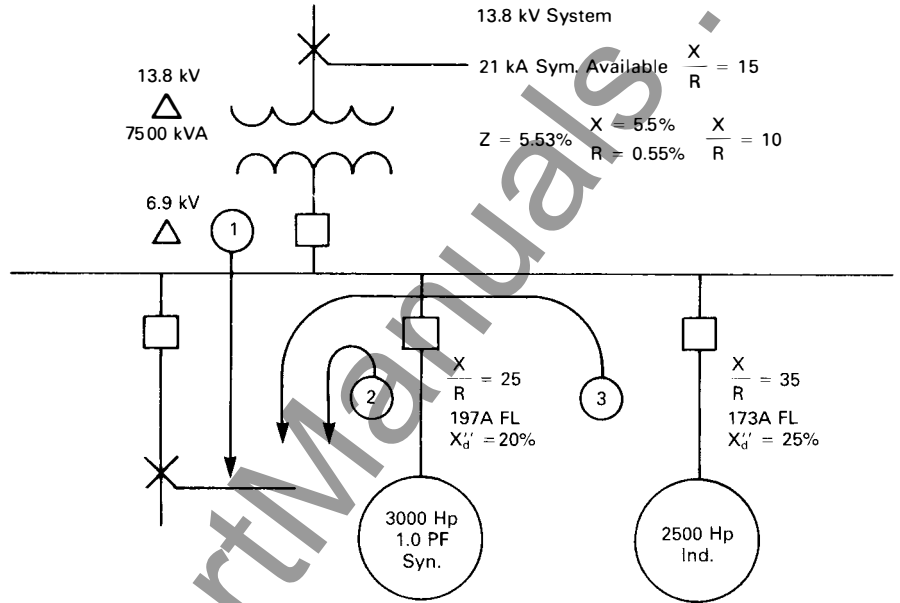

Source of Short Circuit Current	Interrupting E/X Amperes	Momentary E/X Amperes	X/R	X(1)/R(X)	1/R
① Source Transf.	$\frac{.628}{.070} = 8.971$	$\frac{.628}{.070} = 8.971$	11	$\frac{11}{.070}$	= 157
② 3000 HP Syn. Motor	$\frac{.628}{(1.5) .638} = .656$	$\frac{.628}{.638} = .984$	25	$\frac{25}{.638}$	= 39
③ 2500 HP Ind. Motor	$\frac{.628}{(1.5) .908} = .461$	$\frac{.628}{.908} = .691$	35	$\frac{35}{.908}$	= 39
	$I_{3\phi} = 10.088$ or 10.1 kA	10.647 $\times 1.6$ 17.0 kA Momentary Duty		Total 1/R = 235	

$$\text{Total X} = \frac{I_b}{I_{3\phi}} = \frac{.628}{10.1} = .062$$

$$\text{System } \frac{X}{R} = .062 (235) = 14.5 \text{ is Mult. Factor 1.0 from Table 2.}$$

Short circuit duty = 10.1 kA

Type Breaker	V Max.	3 ϕ Sym. Interrupting Capability			Close & Latch or Momentary
		@ V. Max.	Max. KI	@ 6.9 kV Oper. Voltage	
75VCP-W500	8.25 kV	33 kA	41 kA	$\frac{8.25}{6.9} (33) = 39.5 \text{ kA}$	66 kA
150VCP-W500	15 kV	18 kA	23 kA	$\frac{15 (18)}{6.9} (39.1) = 23 \text{ kA}$ (But not to exceed KI)	37 kA

Either breaker could be properly applied, but price will make the type 150VCP-W500 the more economical selection.



Type VacClad-W Medium Voltage Metal-Clad Switchgear

Application on Symmetrical Current Rating Basis, *Continued*

Example 3—Fault Calculations

Check breaker application or generator bus where

Each generator is 7.5 MVA, 4.16 kV 1040 amperes full load, $I_b = 1.04$ kA

Sub transient reactance $X_d'' = 11\%$ or, $X = 11$ pu

Gen $\frac{X}{R}$ ratio is 30

$$\frac{1}{X_s} = \frac{1}{X} + \frac{1}{X} + \frac{1}{X} = \frac{3}{X} \text{ and } \frac{1}{R_s} = \frac{1}{R} + \frac{1}{R} + \frac{1}{R} = \frac{3}{R}$$

$$\text{or } X_s = \frac{X}{3} \text{ and } R_s = \frac{R}{3} \text{ Therefore, System } \frac{X_s}{R_s} = \frac{X}{R} = \text{Gen } \frac{X}{R} = 30$$

Since generator neutral grounding reactors are used to limit the I_{LG} to $I_{3\phi}$ or below, we need only check the $I_{3\phi}$ short-circuit duty.

$$I_{3\phi} = \frac{I_b}{X} + \frac{I_b}{X} + \frac{I_b}{X} = \frac{3I_b}{X} = \frac{3(1.04)}{.11} = 28.4 \text{ kA Sym. E/X amperes}$$

Table 2 System $\frac{X}{R}$ of 30 is Mult. factor 1.04

Short-circuit duty is $28.4 (1.04) = 29.5$ Ka Symmetrical.

3 ϕ Sym. Interrupting Capability

Type Breaker	V Max.	@ V Max.	Max. KI	@ 4.16 kV Oper. Voltage
50VCP-W250	4.76 kV	29 kA	36 kA	$\frac{4.76}{4.16} (29) = 33.2$ kA

The 50VCP-W250 breaker could be applied.

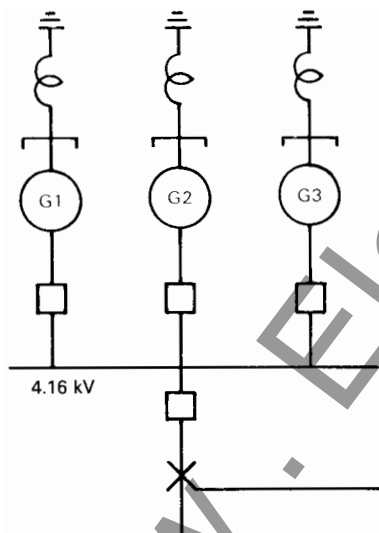

Surge Protection

VacClad-W metal clad switchgear is applied over a broad range of circuits, and is one of many types of equipment in the total system. The distribution system can be subject to voltage transients caused by lightning or switching surges.

Recognizing this phenomenon, the industry has developed standards to provide guidelines for application of electrical equipment, which should be used in the design of distribution systems independent of the breaker interrupting medium. These standards are:

IEEE 288 (1969) - ANSI C37.92 (1972) - IEEE Guide for Induction Motor Protection.

IEEE 242 - 1975 (Buff Book) IEEE Recommended Practice for Protection and Co-ordination of Industrial and Commercial Power Supplies.

IEEE 141 - 1976 (Red Book) Recommended Practices for Electric Power Distribution in Industrial Plants.

ANSI C37.20.2 Metal-Clad and Station-Type Cubicle Switchgear

In general, if the BIL of the system is equal to the BIL of VacClad-W metal clad switchgear, no protection is required against switching surges; however, rotating apparatus rarely meets this criterion. For circuits exposed to lightning, protection is recommended in line with standard practices.

With the wide range of applications, not all circuits require surge protection. Therefore, VacClad-W metal clad switchgear does not include any surge protection as standard. The user exercises the options as to the type of protection deemed necessary, depending on the individual circuit characteristics and cost considerations.

The following recommendations are outlined to provide guidelines of minimum surge protection for metal clad switchgear and the associated system equipment:

1. Lightning - Standard lightning protection: arresters. (Refer to Typical Lightning Arrester Application, Page 15.)
2. Switching surge protection:
 - a. Liquid filled transformer — no surge protection.
 - b. Dry type transformers:
 - 15 kV - 95 kV BIL - no surge protection required.
 - 7.5 kV - 95 kV BIL - no surge protection required.
 - 5 kV - 60 kV BIL - no surge protection required.



Type VacClad-W Medium Voltage Metal-Clad Switchgear

Surge Protection, *Continued*

For all other voltages/BIL ratings for dry type transformers, surge protection (arresters or capacitors) is recommended at the transformer terminals, in line with established practices. Metal oxide surge arresters can be supplied in VacClad-W switchgear as an alternate to the above.

- c. Motors — Surge capacitors at the motor terminals (and surge arresters where appropriate).
- d. Generators — Surge capacitors and station class surge arresters at machine terminals.
- e. Switching overhead lines and underground cables — no surge protection required.
- f. Capacitor Switching — no surge protection required.
- g. Shunt reactor switching — Three phase 15 kV dry-type reactors less than 9 MVA require surge protection at the reactor's terminals.

Metal-oxide surge arresters limit the magnitude of prospective overvoltage, but are ineffective in controlling the rate-of-rise of fast transients which surge capacitors do control. Surge capacitor values recommended are: 0.25 uf on 15 kV systems, and 0.5 uf on 5 kV and 7.5 kV. Reliability of surge capacitors is high, since they are operated at only 50% of the stress of conventional power capacitors. The combination of conservative design and high final test level at 7 times rated voltage for 10 seconds assures the long life and established reliability of surge capacitors. The new metal oxide surge arresters are recommended, and this latest advance in arrester design assures better performance and high reliability of this component utilized in surge protection schemes.

These application guidelines for VacClad-W metal clad switchgear were established after extensive analysis of medium voltage power systems.

Typical Lightning Arrester Application

Operating Voltage kV	Impedance Grounded	Solidly Grounded System
	or Ungrounded System	
2.4	3 kV	3 kV
4.16	6 or 4.5 kV	3 kV
6.9	9 or 7.5 kV	6 kV
12.0	15 kV	9 kV
13.8	15 kV	12 kV

The location of arresters at the junction of cables connected to exposed line may also protect equipment. The following table shows typical maximum cable lengths which can be protected by riser pole arresters, based on typical assumed system parameters and on the full range of known arrester types and makes. Where cable length to equipment exceeds the maximum listed, it is recommended that arresters also be located at the equipment.

Suggested maximum cable length, in feet, between riser pole arresters and protected equipment:

Lightning Arrester Rating	Station Type Arrester	Inter-mediate Type	Distribution Type
To 60 kV BIL Metal-Clad Switchgear			
3 kV	NL	NL	NL
4.5 kV	NL	NL	X
6 kV	NL	NL	70
To 95 kV BIL Metal-Clad Switchgear			
6 kV	NL	NL	NL
7.5 kV	NL	NL	X
9 kV	NL	NL	160
12 kV	NL	240	70
15 kV	110	80	S
To 60 kV BIL Liquid or Gas-Filled Transformer			
3 kV	NL	NL	NL
4.5 kV	NL	NL	X
6 kV	NL	NL	NL
To 75 kV BIL Liquid or Gas-Filled Transformer			
3 kV	NL	NL	NL
6 kV	NL	NL	NL
7.5 kV	NL	NL	X
9 kV	NL	NL	90
To 95 kV BIL Liquid or Gas-Filled Transformer			
9 kV	NL	NL	NL
12 kV	NL	NL	120
15 kV	NL	130	70

NL means no limit to cable length
X means not applicable
S means cable length too short to consider

Instrument Transformers

Instrument transformers are used to protect personnel and secondary devices from high voltage and permit use of reasonable insulating levels and current carrying capacity in relays, meters and instruments. The secondaries of standard instrument transformers are rated at 5 amperes and/or 120 volt, 60 Hertz.

Voltage Transformers

Selection of the ratio for voltage transformers is seldom a question since the primary rating should be equal to or higher than the system line to line voltage. The number of potential transformers per set and their connection is determined by the type of system and the relaying and metering required.

The 3 phase, 3 wire system with 2 element watt-hour meters would require a set of two line to line voltage transformers. If line to ground potential is also required for a directional ground relay, then a set of three line to ground voltage transformers could be used to provide both line to line potential for the 2 element watt-hour meter and line to ground potential for the ground relay.

Ground detection lights or relays for the ungrounded system requires three line to ground voltage transformers and a separate set is usually recommended for this purpose.

The 3 phase, 4 wire, solidly grounded system usually requires three line to ground voltage transformers for 2-1/2 or 3 element metering.

Where synchronizing of generators or systems is involved, it is recommended that only line to line potential be used.

Current Transformers

The current transformer ratio is generally selected so that the maximum load current will read about 70 percent full scale on a standard 5 ampere coil ammeter. Therefore, the current transformer primary rating should be 140 to 150 percent of the maximum load current.

Maximum system fault current can sometimes influence the current transformer ratio selection since the connected secondary devices have published one second ratings.

The zero-sequence current transformer is used for sensitive ground fault relaying or self-balancing primary current type machine differential protection. The zero-sequence current transformer is available with a nominal ratio of 50-5 and available opening size for power cables of 6.5 inches.



Type VacClad-W Medium Voltage Metal-Clad Switchgear

Standard Voltage Transformers • 60 Hertz

Rating-Volts	2400	4200	4800	7200	8400	12000	14400
Ratio	20-1	35-1	40-1	60-1	70-1	100-1	120-1

Switchgear

Voltage Transformers — ANSI Accuracy

kV Class	kV BIL	Max. Number Per Set and Connection	Standard Ratio's	120 Volts at Burden			69.3 Volts at Burden			Thermal Rating 55° C Conn.	Volt-amp
				W, X, Y	Z		W, X	Y	Z		
5	60	2LL or 3LG	20, ① 35, 40	0.3	1.2		0.3			LL 700 LG 400 LG② 700	
7.5 & 15	95	2LL or 3LG	35, 40, 60, 70, 100, 120	0.3	0.3		0.3	0.3	1.2	LL 1000 LG 550 LG② 1000	

① For solidly grounded 4160 volt system only or any type 2400 volt system.

② For solidly grounded system only.

LL = Line to Line connection.

LG = Line to Ground connection.

The minimum number of current transformers for circuit relaying and instruments is three current transformers, one for each phase or two phase connected current transformers and one zero-sequence current transformer. Separate sets of current transformers are required for differential relays.

The minimum pickup of a ground relay in the residual of three phase connected current transformers is primarily determined by the current transformer ratio. The relay pickup can be reduced by adding one residual connected auxiliary current transformer. This connection is very desirable on main incoming and tie circuits of low resistance grounded circuits.

Standard accuracy current transformers are normally more than adequate for most standard applications.

Standard Current Transformers • 55°C Ambient

Current ① Metering Accuracy Classification

Ratings Amperes	60 Hz Standard Burden			① Relaying Accuracy
	B 0.1	B 0.5	B 2.0	
50:5	1.2			C10
75:5	1.2			C20
100:5	1.2			C10
150:5	.6	2.4		C20
200:5	.6	2.4		C20
250:5	.6	2.4		C20
300:5	.6	2.4	2.4	C20
400:5	.3	1.2	2.4	C50
500:5	.3	.3	2.4	C50
600:5	.3	.3	2.4	C100
800:5	.3	.3	1.2	C100
1000:5	.3	.3	.3	C100
1200:5	.3	.3	.3	C200
1500:5	.3	.3	.3	C200
2000:5	.3	.3	.3	C200
2500:5	.3	.3	.3	C200
3000:5	.3	.3	.3	C200
4000:5	.3	.3	.3	C200
4000:4	.3	.3	.3	C200

① Accuracy meets or exceeds accuracy in proposed ANSI C37.20.2.

Control Equipment

Circuit Breaker Control

The VCP-W circuit breaker has a motor charged spring type stored energy closing mechanism. Closing the breaker charges accelerating springs. Protective relays or the control switch will energize a shunt trip coil to release the accelerating springs and open the breaker. This requires a reliable source of control power for the breaker to function as a protective device.

For ac control, a capacitor trip device is used with each circuit breaker shunt trip and each WL-2 lockout relay to insure that energy will be available for tripping during fault conditions. A control power transformer is required on the source side of each incoming line breaker. Closing bus tie or bus sectionalizing breakers will require automatic transfer of control power. This control power transformer may also supply other ac auxiliary power requirements for the switchgear.

Dc control would require a dc control battery, battery charger and an ac auxiliary power source for the battery charger. The battery provides a very reliable dc control source, since it is isolated from the ac power system by the battery charger. However, the battery will require periodic routine maintenance and battery capacity is reduced by low ambient temperature.

Any economic comparison of ac and dc control for switchgear should consider that the ac capacitor trip is a static device with negligible maintenance and long life, while the dc battery will require maintenance and replacement at some time in the future.

VCP-W Breaker Stored Energy Mechanism Control Power Requirements

Rated Control Voltage	Spring Charge Motor		Close or Trip Amperes	Voltage Range		Ind. Light Amperes
	Run Amperes	Time Sec.		Close	Trip	
48 V dc	9.0	6	16	38-56	28-56	.035
125 V dc	4.0	6	7	100-140	70-140	.035
250 V dc	2.0	6	4	200-280	140-180	.035
120 V ac	4.0	6	6	104-127	104-127	.035
240 V ac	2.0	6	3	208-254	208-254	.035

Control Power Transformers • Disconnect Type • 1 Phase • 60 Hertz

Primary Volts①

Taps	Secondary Volts			kVA	kV Class
	+ 7½%	Rated	- 7½%		
2580	2400	2220	240/120	5, 10, 15	5
4470	4160	3850	240/120	5, 10, 15	5
5160	4800	4400	240/120	5, 10, 15	5
7740	7200	6680	240/120	5, 10, 15	15
12900	12000	11100	240/120	5, 10, 15	15
14300	13300	12300	240/120	5, 10, 15	15

① Line to line connection only available.



Type VacClad-W Medium Voltage Metal-Clad Switchgear

Typical Applications		Permissive Local Control		General Auxiliary Switch applications, Indicating lights, Alarm, Supv. Control Indicator, Field application, etc.		Start-run Breaker Interlocking		Capacitor Trip Recloser		Interlocking to prevent Parallel Operation of Breakers Motor Space Heaters		Start-run Breaker Interlocking			
		Type Auxiliary Switch or Device (supplied only when required.)		TOC Switch		Breaker Auxiliary Switch		TOC and Auxiliary Switch		MOC Switch Operating Position		MOC Switch Operating and Test Position		SG or MG6 Auxiliary Relay	
Breaker Condition		Shown for Breaker in Test Position		Shown for Breaker in Open Position		Shown for Breaker in Open Position		Shown for Breaker in Open Position		Shown for Breaker in Open Position		Shown for Breaker in Open Position		Note ①	
Operating Position	Close	X		X		X		X		X		X		X	
Operating Position	Open	X			X		X		X		X		X		X
Test Position	Close		X	X		X		X		X		X		X	
	Open		X		X		X		X		X		X		X
Withdrawn			X				X		X		X		X		X

① MOC Switch preferred unless scheme is fail safe on coil failure.
X indicates switch contact or circuit closed.

Auxiliary Switches

Optional circuit breaker and cell auxiliary switches are available where needed for interlocking or control of auxiliary devices. Typical applications and operation are described in the following table.

Auxiliary switch contacts from the circuit breaker mechanism are limited in number by the breaker control requirements usually to one 'a' and two 'b' contacts for ac control or two 'a' and two 'b' contacts for dc control.

When additional auxiliary contacts are needed, the optional auxiliary relay or mechanism operated cell (MOC) switch is used. Three types of MOC switches are available:

- (a) operates with breaker in connected position only
- (b) operates with breaker in connected position and test position
- (c) operates with breaker in connected position but operates with breaker in test position only if so manually selected.

The optional truck operated cell (TOC) switch operates when the circuit breaker is levered into or out of the operating position.

Interrupting Capacity Auxiliary Switch Contacts

Type Auxiliary Switch	Continuous Current Amperes	Control Circuit Voltage				
		120 ac	240 ac	48 dc	125 dc	250 dc
Non-inductive circuit interrupting capacity in amperes						
Breaker Auxiliary Switch	20	20	20	15	10	5
TOC	20	20	20	15	10	5
MOC Auxiliary Switch	20	20	20	15	10	5
Inductive circuit interrupting capacity in amperes						
Breaker Auxiliary Switch	20	15	10	15	10	5
TOC Auxiliary Switch	20	15	10	15	10	5
MOC Auxiliary Switch	20	15	10	15	10	5

Auxiliary switch contacts are primarily used to provide interlocking in control circuits, switch indicating lights, auxiliary relays or other small loads. Suitability for switching remote auxiliary devices, such as motor heaters or solenoids, may be checked with the interrupting capacity listed in the following table. Where higher interrupting capacities are required, an interposing contactor should be specified.



Type VacClad-W Medium Voltage Metal-Clad Switchgear

Supplemental Devices

● Ground and Test Device

The ground and test device is a drawout element that may be inserted into a Metal-Clad Switchgear housing in place of a circuit breaker to provide access to the primary circuits to permit the temporary connection of grounds or testing equipment to the high voltage circuits. High potential testing of cable or phase checking of circuits are typical tests which may be performed. The devices are insulated to suit the voltage rating of the switchgear and will carry required levels of short circuit current.

Before using ground and test devices it is recommended that each user develop detailed operating procedures consistent with safe operating practices. Only qualified personnel should be authorized to use ground and test devices.

Manual ground and test devices are available. These devices include six studs for connection to primary circuits. On the manual device, selection and grounding is accomplished by cable connection.

Standard accessories:

- 1 - test jumper
- 1 - levering crank
- 1 - maintenance tool
- 1 - lifting yoke
- 1 - transport dolly (optional)
- 1 - portable lifter (optional)
- 1 - test cabinet (optional)
- 2 - sets of rails
- 1 - set of rail clamps

Dimensions (Inches) and Installation Elevations

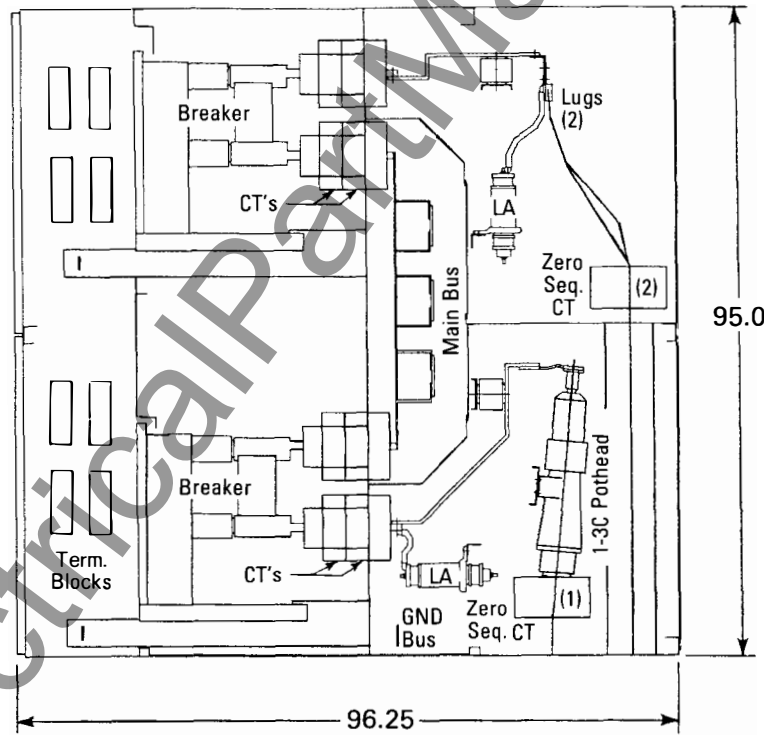
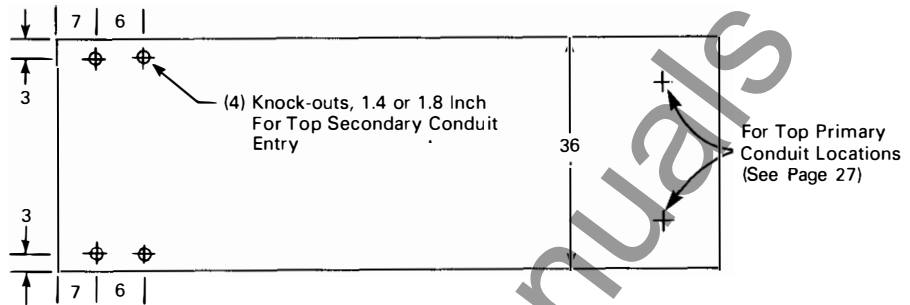

Ⓐ = 32 minimum recommended left or right hinged panel clearance.

Ⓑ = 36 minimum recommended rear clearance.

Typical Indoor Elevation

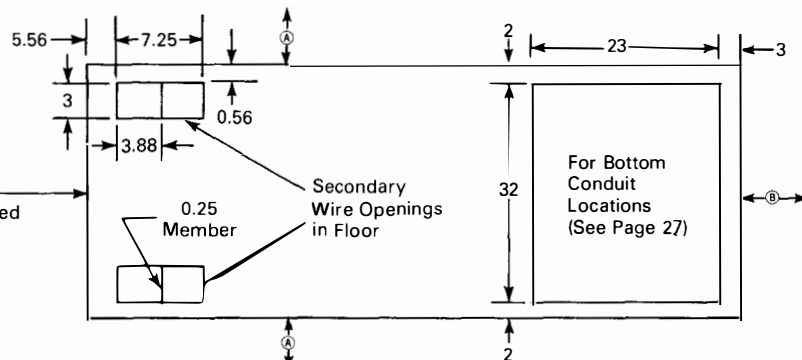

Typical Indoor Base Plan



Type VacClad-W Medium Voltage Metal-Clad Switchgear

Dimensions (Inches) and Installation, Continued

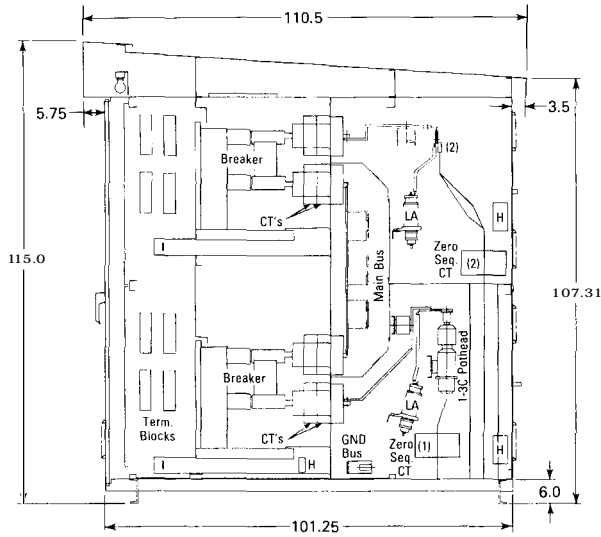

Outdoor
Aisle-Less

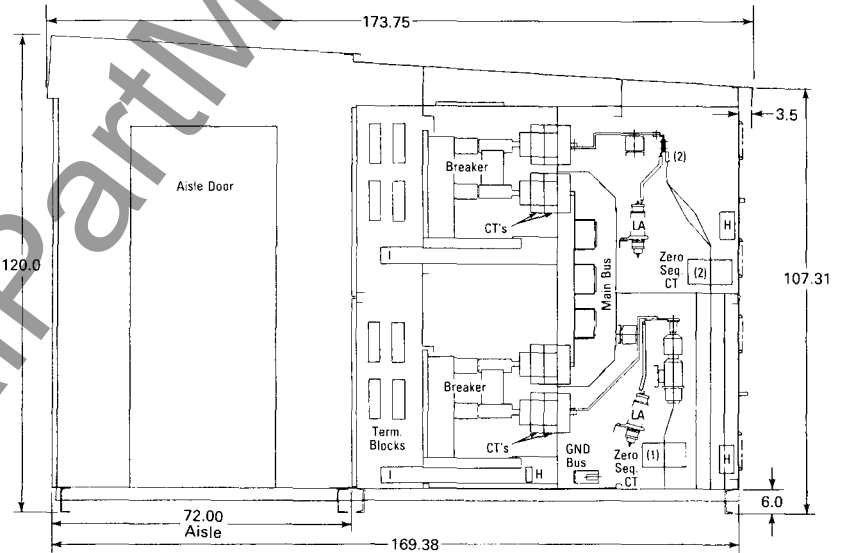

Outdoor
Sheltered Aisle
Single Row

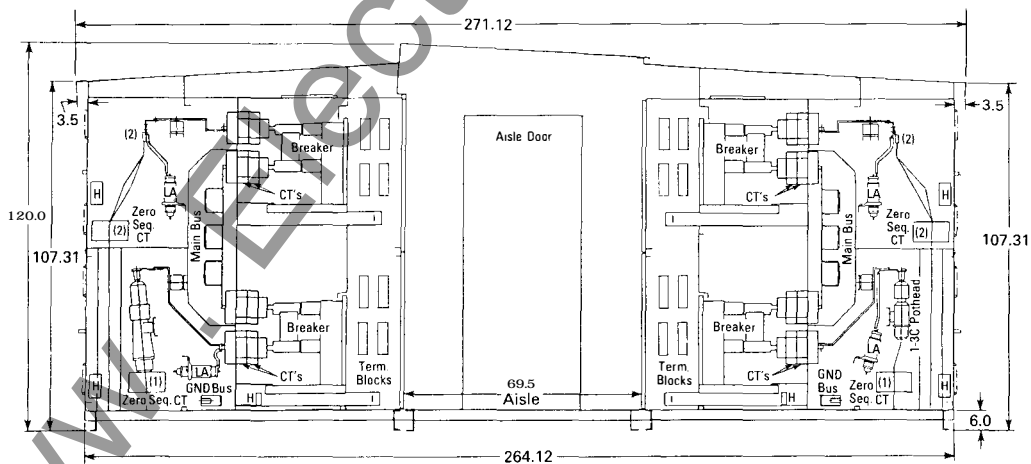

Outdoor
Sheltered Aisle
Double Row

Dimensions, Inches

Note: Dimensions not to be used for construction.
These shown are for reference only. Consult
Westinghouse for exact dimensions.

January, 1989



Type VacClad-W Medium Voltage Metal-Clad Switchgear

Shipping and Receiving

VacClad-W metal-clad switchgear is shipped in groups of one or more units. Each group is designed and braced to withstand shipment by truck, rail, or ship. Indoor groups are bolted to skids and enclosed in a protective covering. Because of their structural base, outdoor groups do not need skids. For sheltered-aisle a protective covering is located across the front of each shipping group. Aisle-less gear is protected by its own weatherproof enclosure. VCP-W circuit breakers, accessories, and installation materials are packed and crated separately. Appendages such as bus runs and synchronizing panels and large internal equipment may also be packed and crated separately. When received, the purchaser should check the material against the shipping list. If loss or damage is discovered, file claims with the transportation company and notify the nearest Westinghouse representative.

Handling

VacClad-W Metal-Clad Switchgear is equipped for handling by crane. In addition, it is provided with shipping braces and jack supports. It is recommended that the groups be lifted into position by crane. However, if no crane is available they may be skidded into place on rollers using jacks to raise and lower the group.

Type VCP-W breakers are crated so as to be handled by crane or industrial "fork" truck. After uncrating, breakers may be lifted by crane.

Storing

Switchgear which cannot be installed and put into service immediately must be stored so as to maintain the equipment in a clean and dry condition. Storage in a heated building is recommended. If stored outdoors, special precautions must be taken: indoor switchgear must be covered and temporary heating equipment installed, outdoor switchgear must be supplied with temporary power for operation of the space heaters.

Installation and Field Assembly

Westinghouse VacClad-W switchgear is factory-tested and factory-assembled from accurately tooled parts upon true and level bedplates. A minimum of installation and field assembly time will be required if the procedures described on the drawings and in the instructions are adhered to.

The foundation for indoor switchgear should consist of rugged steel channels imbedded in a concrete floor. The steel channels must be flat, level, and in a true plane with each other. The finished floor must be in a true plane with the steel channels and must not project above the level of the steel channels.

The foundation for outdoor switchgear may be a concrete pad, or footers placed parallel with the length of the line-up. For any condition, the aisle-less switchgear requires a reasonably level and smooth pad for breaker drawout. The integral base furnished with outdoor switchgear should be supported in a level and true plane.

Field assembly of the outdoor aisle and of some weather-proofing is required. These parts are standardized and tool-made to simplify and expedite their assembly. The details of assembly are described in the job instruction book and associated drawings.

Typical Weights in Pounds Assemblies (Less Breakers)

Type of Vertical Section	Main Bus Rating Amps	Indoor		Sheltered-Aisle Including Aisle	
		Aisle less Lbs	Aisle less Lbs	Single Row (Lbs)	Double Row (Lbs)
BIB	1200	2400	3000	4200	7200
	2000	2500	3100	4300	7400
	3000	2600	3200	4400	7600
BIA or AIB	1200	2300	2900	4100	7000
	2000	2400	3000	4200	7200
	3000	2500	3100	4300	7400
AIA	1200	2000	2600	3800	6400
	2000	2100	2700	3900	6600
	3000	2220	2800	4000	6800

Breakers — Weights in Pounds

(Impact Weight = 1.5 X Breaker Weight)

Type of Breaker	Current Rating, Amps.		
	1200	2000	3000
Approx. Wt., Lbs.			
50VCP-W 250	350	410	525
50VCP-W 350	460	490	525
75VCP-W 500	375	410	525
150VCP-W 500	350	410	525
150VCP-W 750	350	410	525
150VCP-W 1000	460	490	525



Type VacClad-W Medium Voltage Metal-Clad Switchgear

Standard Designs — Vertical Sections (96.25 In. Deep) General Arrangement

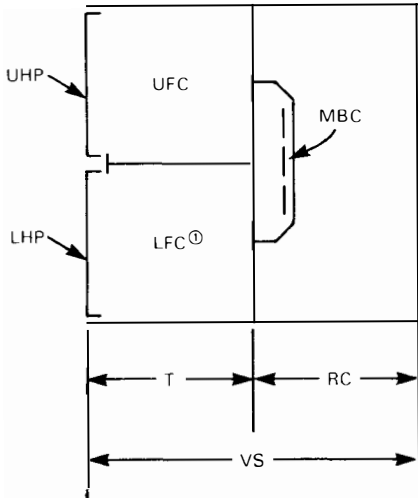

General Arrangement

- UHP Upper Hinged Panel
- LHP Lower Hinged Panel
- MBC Main Bus Compartment— 1200, 2000, 3000A as required
- UFC Upper Front Compartment
- LFC Lower Front Compartment
- RC Rear Compartment
- T Type of Vertical Section: Defined by combinations of UFC and LFC
- VS Complete Vertical Section: Defined by combinations of T and RC

Types of Vertical Sections

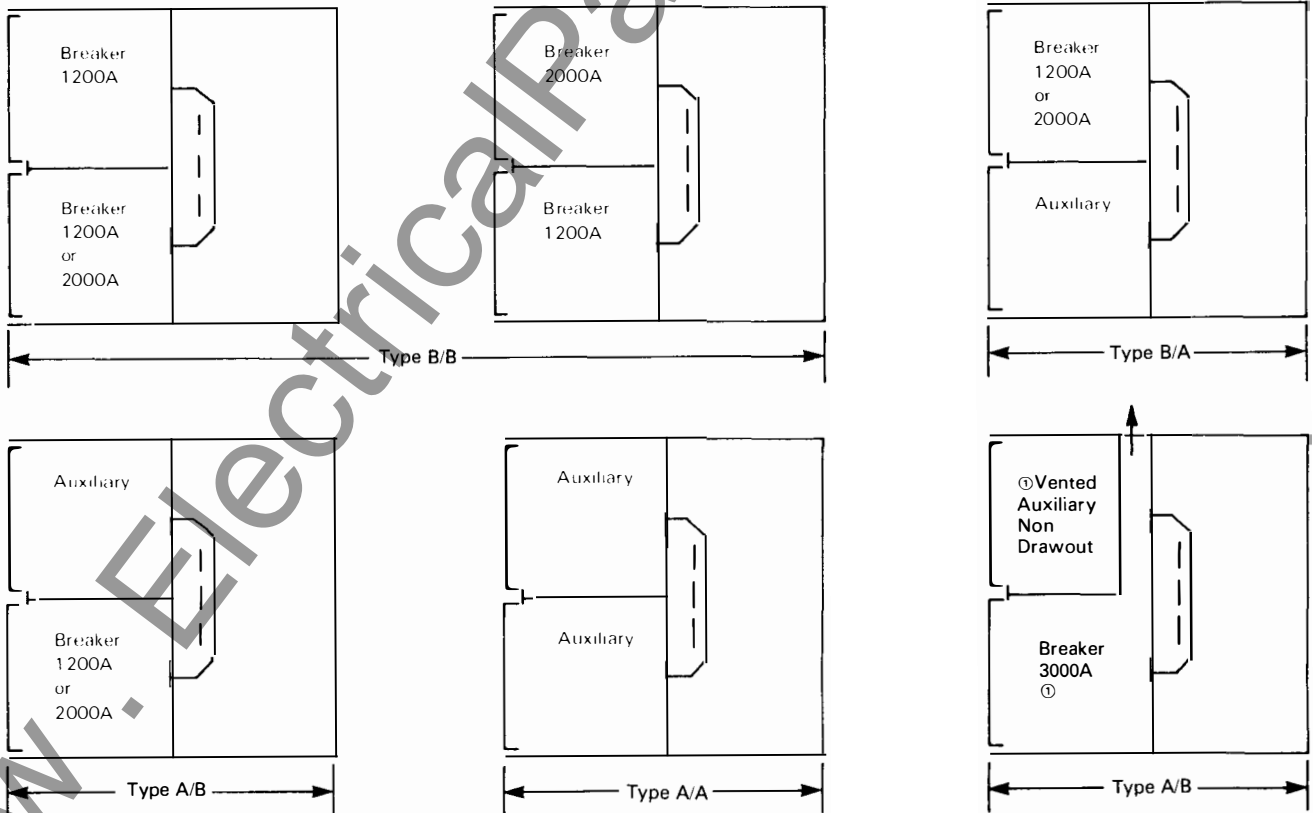

① Caution: 3000 amp breaker located in LFC requires vented auxiliary in UFC.
Refer to page 25 for 3000 A breaker in UFC.



Type VacClad-W Medium Voltage Metal-Clad Switchgear

Standard Designs — Vertical Sections (96.25 In. Deep), *Continued*
 Front Auxiliary Compartments

Upper Auxiliaries

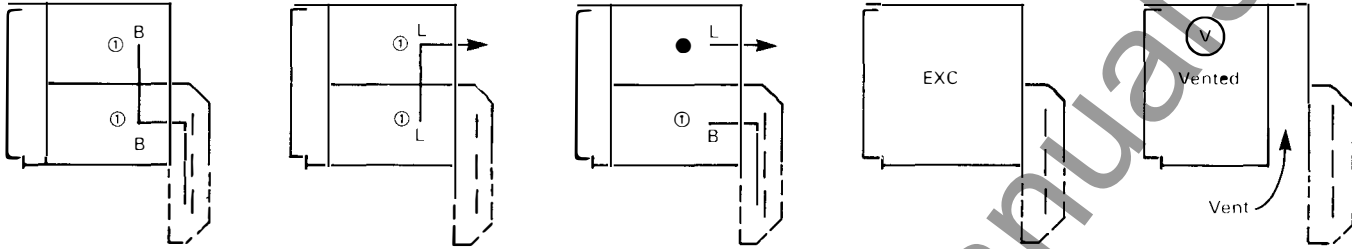

Lower Auxiliaries

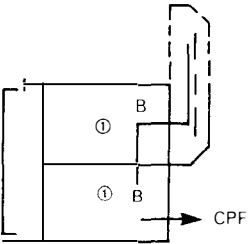
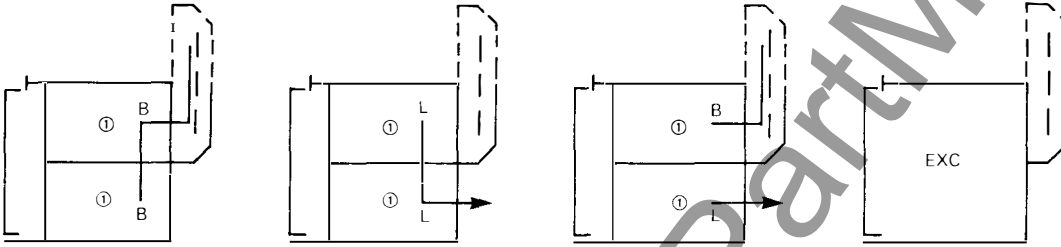

- ⓪ CPD, Fuse or VT.
- CPD Drawout cont. pwr. trans: Fused primary, mechanically interlocked secondary breaker, single phase, line to line, 15 kVA Max.
- CPF Fixed cont. pwr. trans.
- Fuse Drawout fuses for CPF: Mechanically interlocked secondary breaker, three max, 25E max
- PT Drawout pot. trans.: Fused primary and secondary, three in WYE max, two in open delta max
- B Bus connection
- L Line connection
- EXC Brushless exciter auxiliary secondary and control



Type VacClad-W Medium Voltage Metal-Clad Switchgear

Standard Section Views

Breaker-Over-Breaker (B/B) — Top Power Conductor Entrance

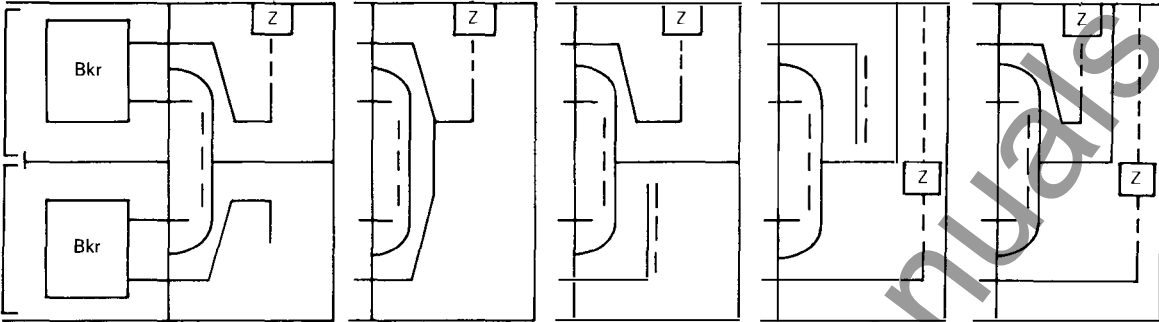

Figure 1

Figure 2

Figure 3

Figure 4

Figure 5

Breaker-Over-Breaker (B/B) — Bottom Power Conductor Entrance

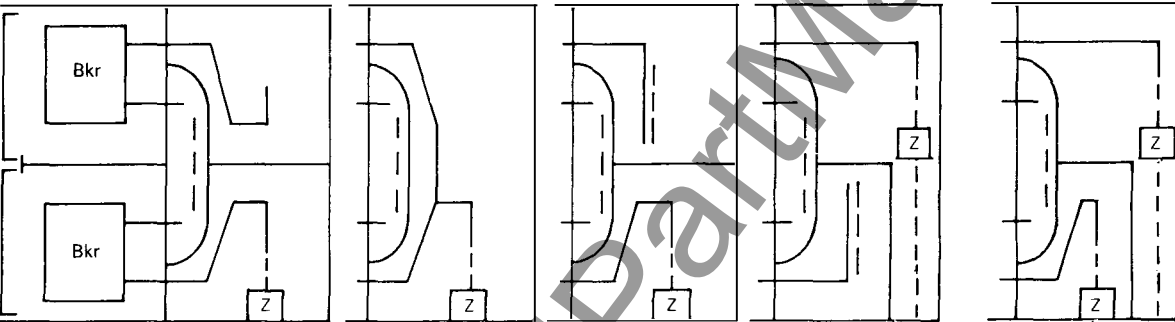

Figure 1

Figure 2

Figure 3

Figure 4

Figure 5

Breaker-Over-Auxiliary (B/A) — Top Power Conductor Entrance

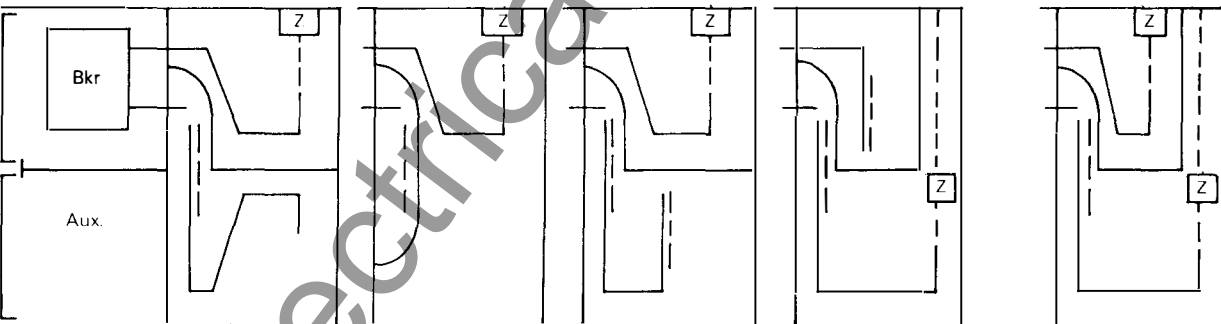

Figure 1

Figure 2

Figure 3

Figure 4

Figure 5

Breaker-Over-Auxiliary (B/A) — Bottom Power Conductor Entrance

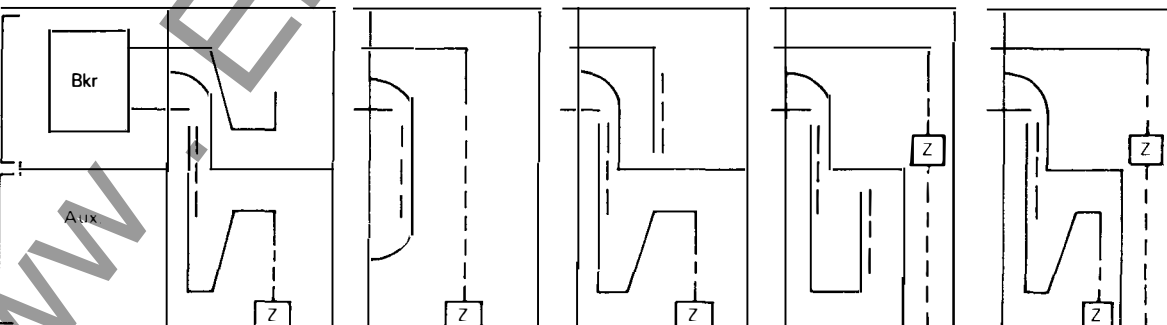

Figure 1

Figure 2

Figure 3

Figure 4

Figure 5

Z = Zero Sequence Current Transformer



Type VacClad-W Medium Voltage Metal-Clad Switchgear

Standard Section Views, *Continued*

Auxiliary-Over-Breaker (A/B) — Top Power Conductor Entrance

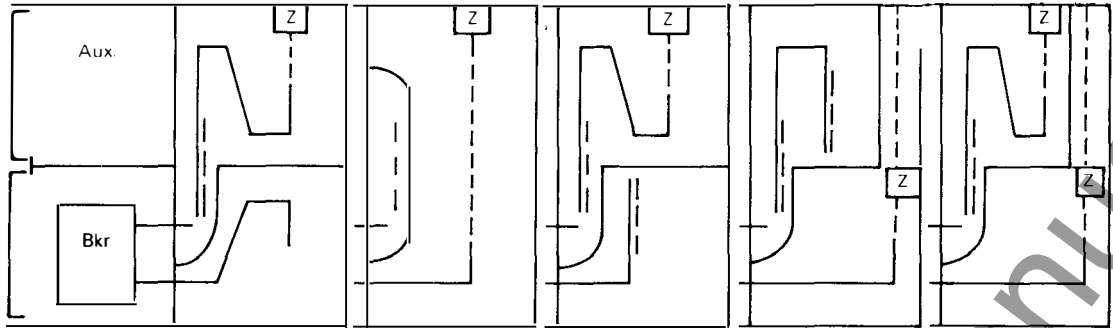

Figure 1 Figure 2 Figure 3 Figure 4 ● Figure 5

Auxiliary-Over-Breaker (A/B) — Bottom Power Conductor Entrance

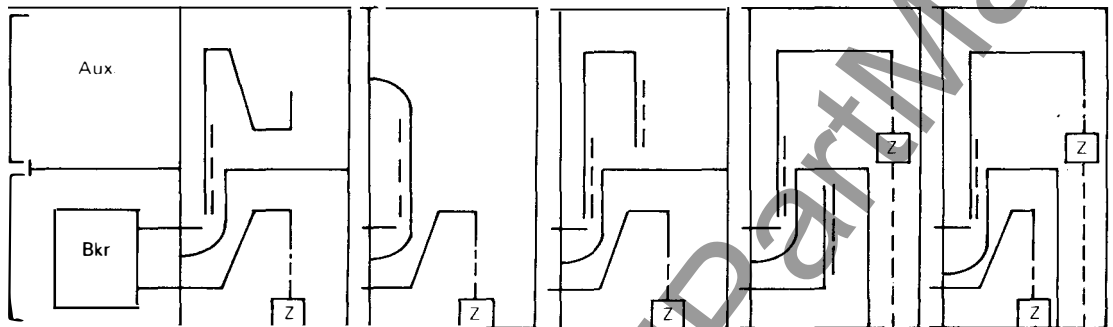

Figure 1 Figure 2 Figure 3 ⊙ Figure 4 Figure 5

Auxiliary-Over-Auxiliary (A/A) — Top Power Conductor Entrance

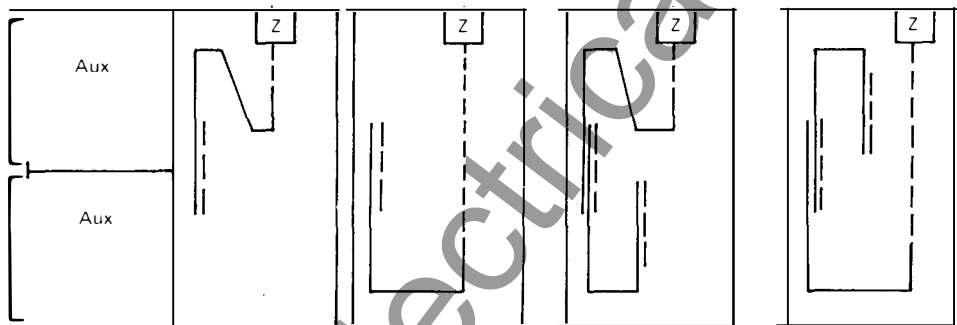

Figure 1 Figure 2 Figure 3 Figure 4

Auxiliary-Over-Auxiliary (A/A) — Bottom Power Conductor Entrance

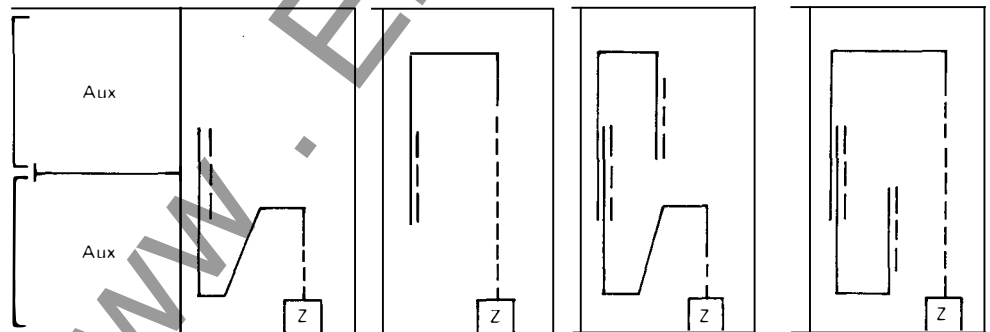

Figure 1 Figure 2 Figure 3 Figure 4

Z = Zero Sequence Current Transformer

⊙ Caution: 3000 amp bus sectionalizing is available, but with no power conductor entrances.



Type VacClad-W Medium Voltage Metal-Clad Switchgear

Standard Section Views, *Continued*

3000A Configurations

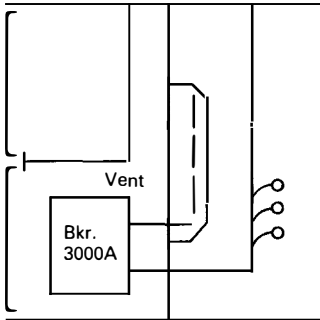

Figure 1

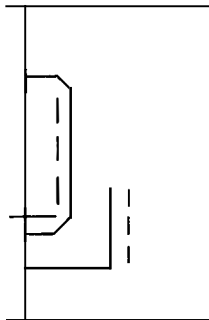

Figure 2

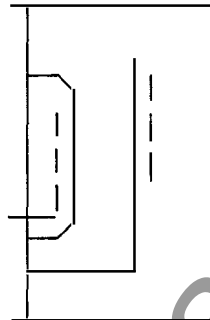

Figure 3

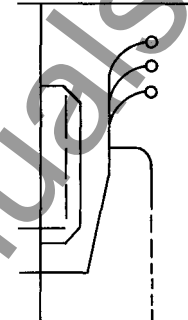

Figure 4

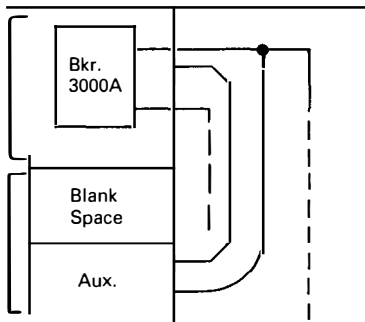

Figure 1

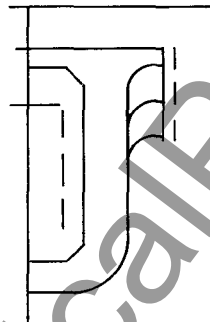

Figure 2

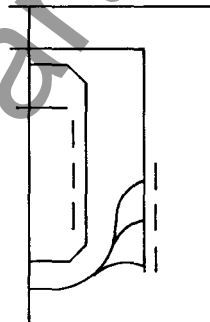

Figure 3

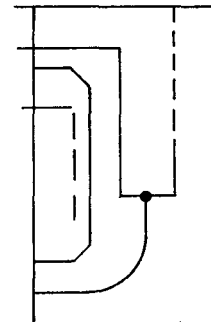
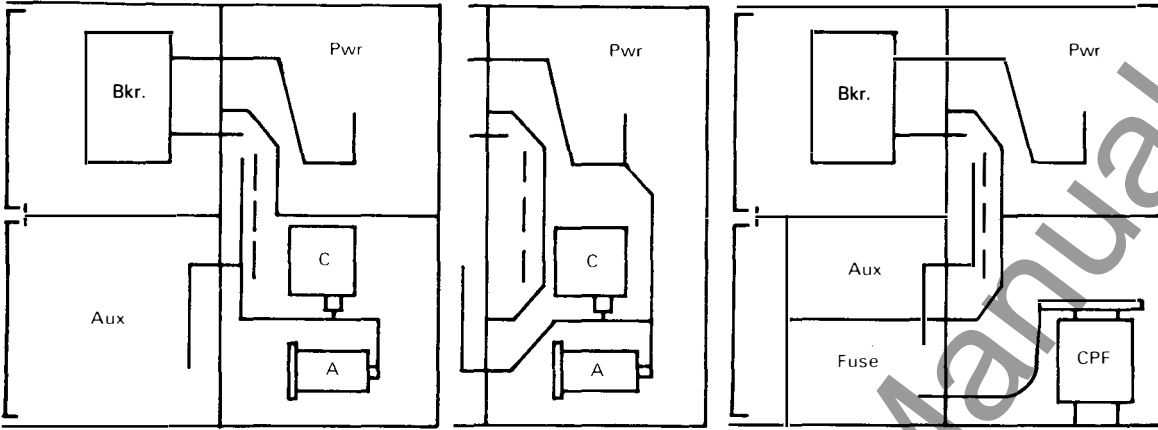

Figure 4



Type VacClad-W Medium Voltage Metal-Clad Switchgear

Standard Designs — Vertical Sections (96.25 In. Deep)
 Arresters, Capacitors, and Fixed Control Pwr. Trans.



Type B-A (Typical)

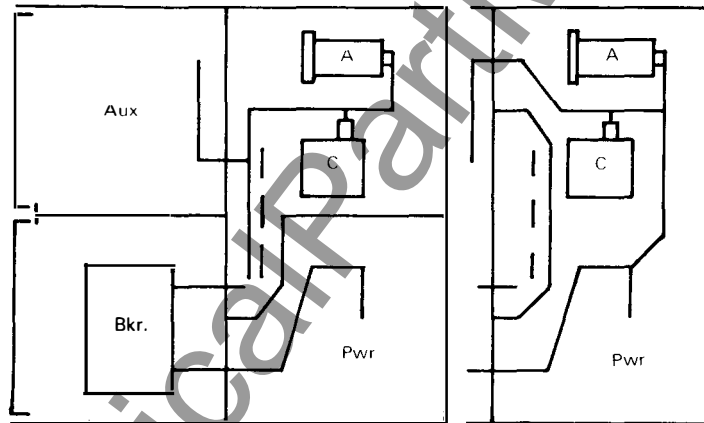

Type A/B (Typical)

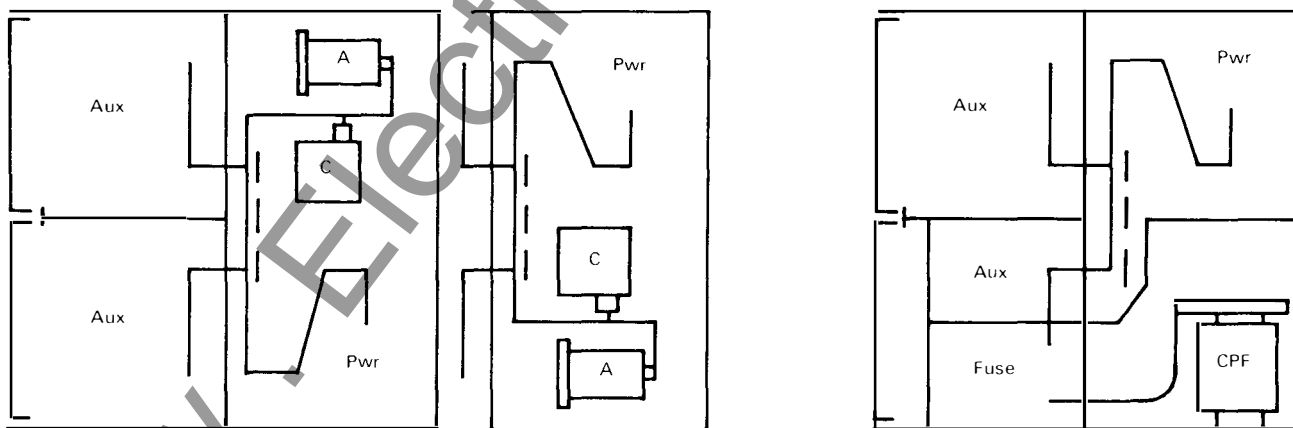

Type A/A (Typical)

- A Arrester, Station Type
- B Breaker, 1200A or 2000A
- C Capacitor, Surge
- CPF Control Pwr Trans, Fixed, One Phase, 50 kVA Max or Three Phase, kVA Max
- Pwr Power Conductor Arrangement
- Aux Auxiliaries



Type VacClad-W Medium Voltage Metal-Clad Switchgear

Standard Designs — Vertical Sections (96.25 In. Deep), *Continued* Primary Cable Entrance (Top Elevation or Base Plan)

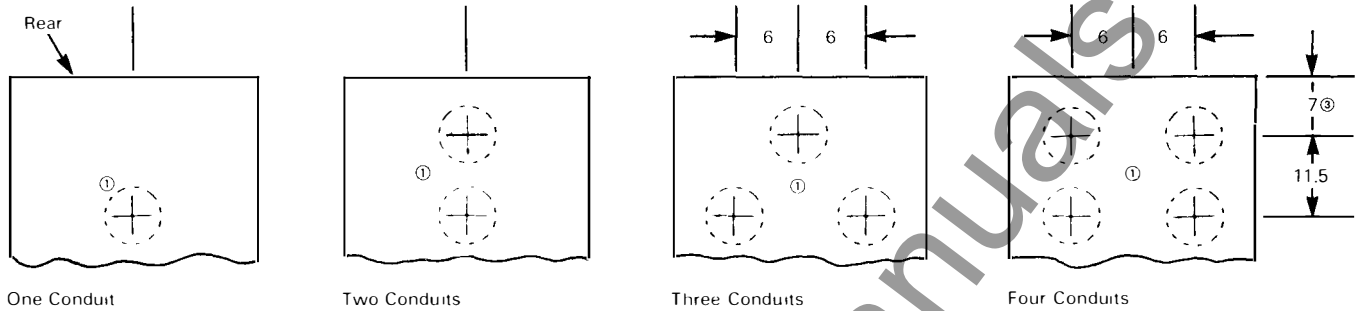

Fig. A — For Entrances Into Compartment Without Cable Enclosure

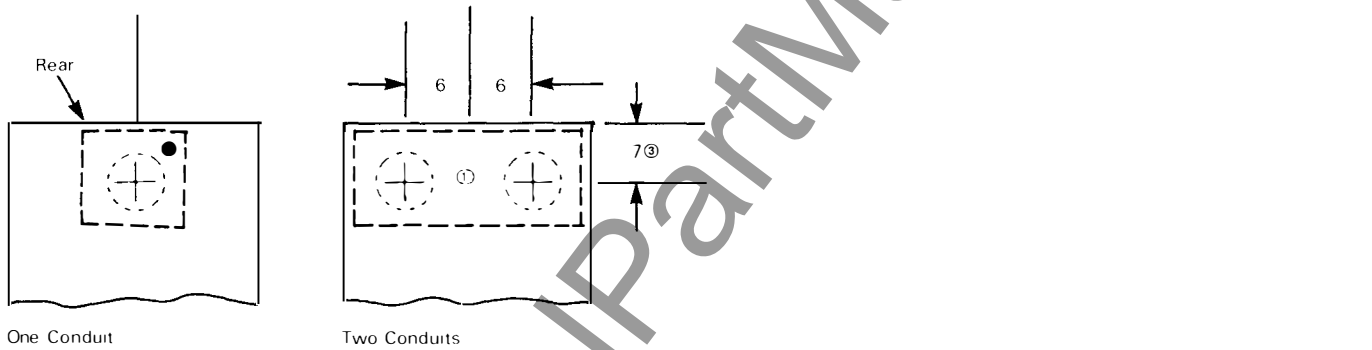

Fig. B — For Entrances Into Cable Enclosure (Or Cable Enclosure Area)

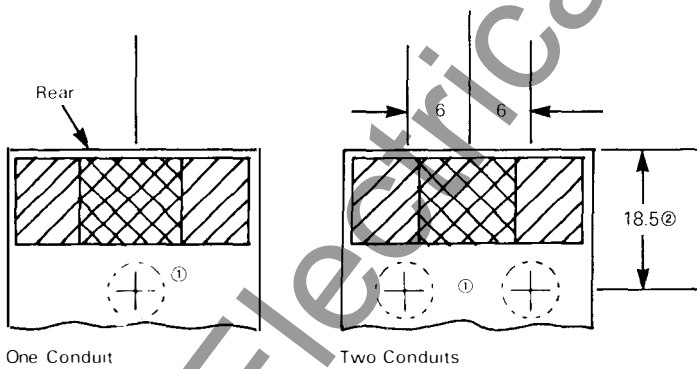

Fig. C — For Entrances Into Compartment With Cable Enclosure

- ① Primary cable and conduit entrance must be within 6.5 in. diameter entry area.
- ② Changes to 19.75 for optional hinged rear doors (structure depth becomes 97.5 inches).
- ③ Changes to 8.25 for optional hinged rear doors (structure depth becomes 97.5 inches).



Type VacClad-W Medium Voltage Metal-Clad Switchgear

How to Arrange, Select, and Specify VacClad-W

Arrange a primary one line as typically shown below. Note that the chart identifies the specific vertical sections (or rear compartments) selected based primarily upon the direction of power conductor entrance.

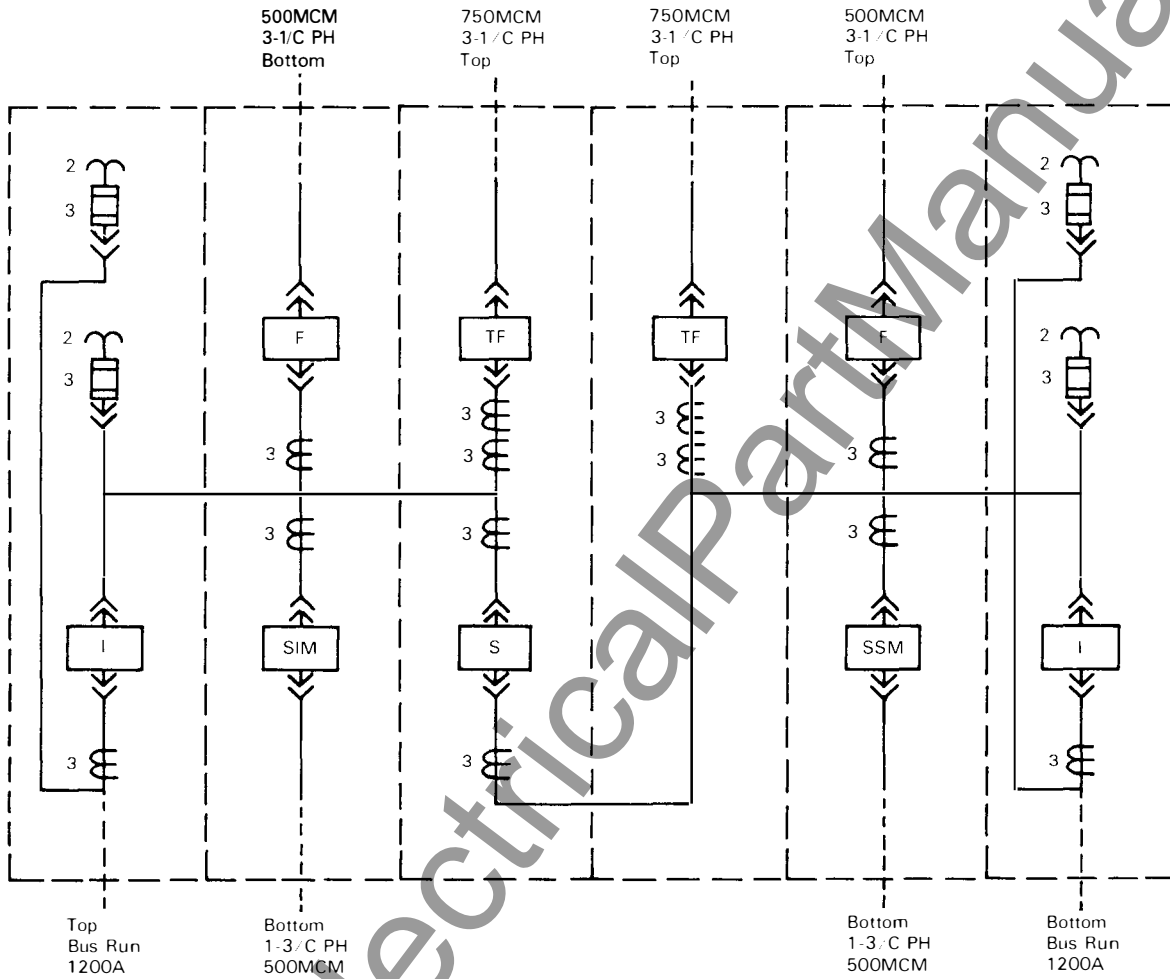



Type VacClad-W Medium Voltage Metal-Clad Switchgear

How to Arrange, Select and Specify VacClad-W, *Continued*

Select your list of components. (The primary one line instrument transformer details can now be completed.) Typical arrangement for the primary one line is shown on the front view below.

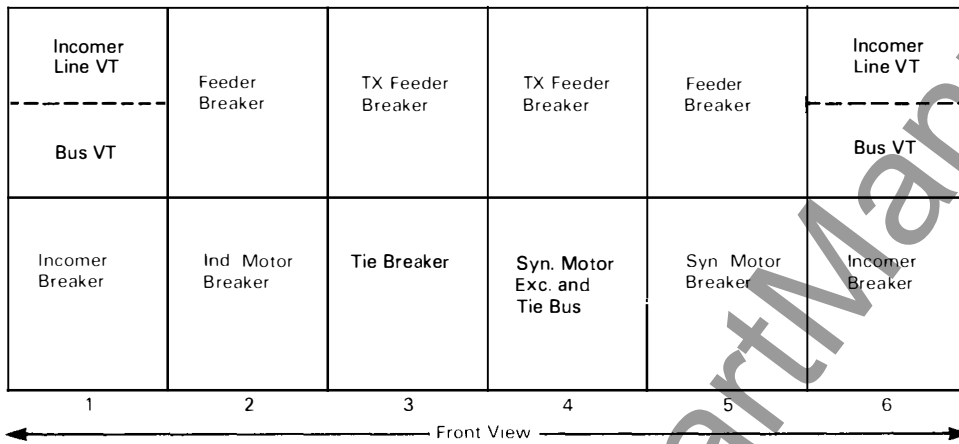

General Information Required

Specify the following general information:

- a. Indoor, aisle-less, or sheltered-aisle (single or double row)
- b. Shipping group limitations
- c. System voltage, frequency, phase sequence, and grounding
- d. System MVA or short circuit requirements
- e. Main bus continuous current rating
- f. Control voltage
- g. Control cable entrance (Top or bottom and vertical section)

Compartment Information Required

Specify the following information for each compartment:

- a. Circuit nameplate wording
- b. Breaker continuous current rating
- c. Identification of remote equipment controlled by VacClad-W
- d. Relay characteristics
- e. If not on primary one line:
 - Instrument transformer ratios
 - Complete power conductor information—top or bottom, size, number, type of termination



Type VacClad-W Medium Voltage Metal-Clad Switchgear

Typical Specifications

Item No. _____

— kV Metal-Clad Switchgear

— Complete assembly of kV, [Indoor] [Outdoor Aisle-less] [Outdoor Sheltered Aisle] Metal-Clad Switchgear for the _____

VacClad-W Switchgear will consist of a stationary structure assembly and one or more removable type vacuum circuit breakers. The switchgear assembly will be constructed from individual vertical sections. They will be bolted together to form a rigid metal-clad switchgear assembly. Metal side sheets will provide grounded barriers between adjacent structures. Solid removable metal barriers will isolate the primary major sections of each circuit. Rear sheets will be steel with two pieces per vertical section to provide circuit isolation and ease of handling. Final finish is a coat of light gray paint, ANSI #61.

The main bus will be copper and will have fluidized bed epoxy flame-retardant and track-resistant insulation. Bus supports between units will be flame-retardant, track-resistant, glass polyester. All bus joints will be plated, bolted and insulated with easily installed boots. The bus will be braced to withstand fault currents equal to the close and latch rating of the breakers. The temperature rise of the bus and connections will be in accordance with ANSI standards and documented by design tests. A ground bus will extend the entire length of the switchgear.

Each circuit breaker compartment will be equipped to house a removable breaker element. The mechanism for levering the breaker will be cell mounted. It will include all of the necessary interlocks to render the breaker mechanism mechanically trip free during the levering procedure. The stationary primary contacts will be silver-plated and recessed within insulating tubes. A steel shutter will automatically cover the stationary primary disconnecting contacts when the breaker is in the disconnected position or out of the cell. Rails will allow withdrawal of each circuit breaker for inspection and maintenance without the use of a separate lifting device.

Each type vacuum breaker will be horizontal drawout type, capable of being withdrawn on rails. The breaker will be operated by a motor charged spring type stored energy mechanism, charged normally by a universal electric motor. In an emergency, charging will be by a manual handle. The primary disconnecting contacts will be silver-plated copper. Each circuit breaker will contain vacuum interrupter assemblies which can be removed as complete units. The vacuum interrupter pole unit will be mounted on glass polyester supports. A contact wear gap indicator, which requires no tools to determine available contact life, will be provided. The current transfer from the vacuum interrupter moving stem to the breaker main conductor will be a non-sliding design. The breaker front panel will be removable when the breaker is withdrawn for inspection or maintenance.

[Outdoor Aisle-less Enclosure]

The metal-clad switchgear includes aisle-less outdoor construction.

The basic switchgear units are surrounded by a complete weatherproof enclosure of heavy gauge steel. A weatherproof door is provided on the breaker drawout side of each housing. Lights, space heaters, and receptacles are provided inside each unit.

An undercoating compound is applied to the underside of all bottom surfaces.

[Outdoor Sheltered-Aisle Enclosure]

The metal-clad switchgear includes Outdoor Sheltered-Aisle Enclosure walk-in construction.

The basic switchgear units are installed in a heavy-gauge steel enclosure which provides a sheltered aisle space in front of the switchgear and complete weather protection for the equipment. Doors, provided with "crash" latch mechanisms are located at both ends of the lineup. The aisle has sufficient area to permit interchanging breakers between cells. Aisle lights, switches, ground fault service receptacles and space heaters are provided in each line-up.

An undercoating compound is applied to the underside of all switchgear units. The Sheltered-Aisle is shipped assembled, minimizing field erection time and expense.

A basic compartment containing a circuit breaker element is provided with the following equipment:

- 1 – Metal-clad stationary cell
- 1 – Vacuum circuit breaker removable element
- 1 – Set of three 2-hole NEMA drillings for each set of primary conductors
- 1 – Control power cutout
- 1 – Breaker control switch with red and green indicating lights



Type VacClad-W Medium Voltage Metal-Clad Switchgear

[Other Equipment:]

Unit No. _____ (_____)

[_____]
[_____]
[_____]
[_____]
[_____]
[_____]
[_____]
[_____]
[_____]
[_____]
[_____]

- ____ - Auxiliary unit(s) [each] with the following total devices:
- ____ - Set(s) of main bus, rated _____ A
- ____ - Set(s) bar risers to bus run _____ A
- [____ - Bus transition(s)]
- [____ - Bus entrance(s)]
- [____ - _____]
- [____ - Voltage transformers drawer mounted, with current-limiting primary fuses, ratio _____ kV; 120 V, connected _____]
- [____ - _____ kVA _____ phase dry-type control power transformer(s) with current-limiting primary fuses, secondary breaker, interlocks, compartment provisions and connections]
- ____ - Indicating AC Ammeter(s)
- ____ - Ammeter transfer switch(es)
- ____ - Indicating AC Voltmeter(s)
- ____ - Voltmeter transfer switch(es)
- [____ - Indicating Wattmeter(s)]
- [____ - _____]
- [____ - _____]



VacClad-W Medium Voltage Metal-Clad Switchgear

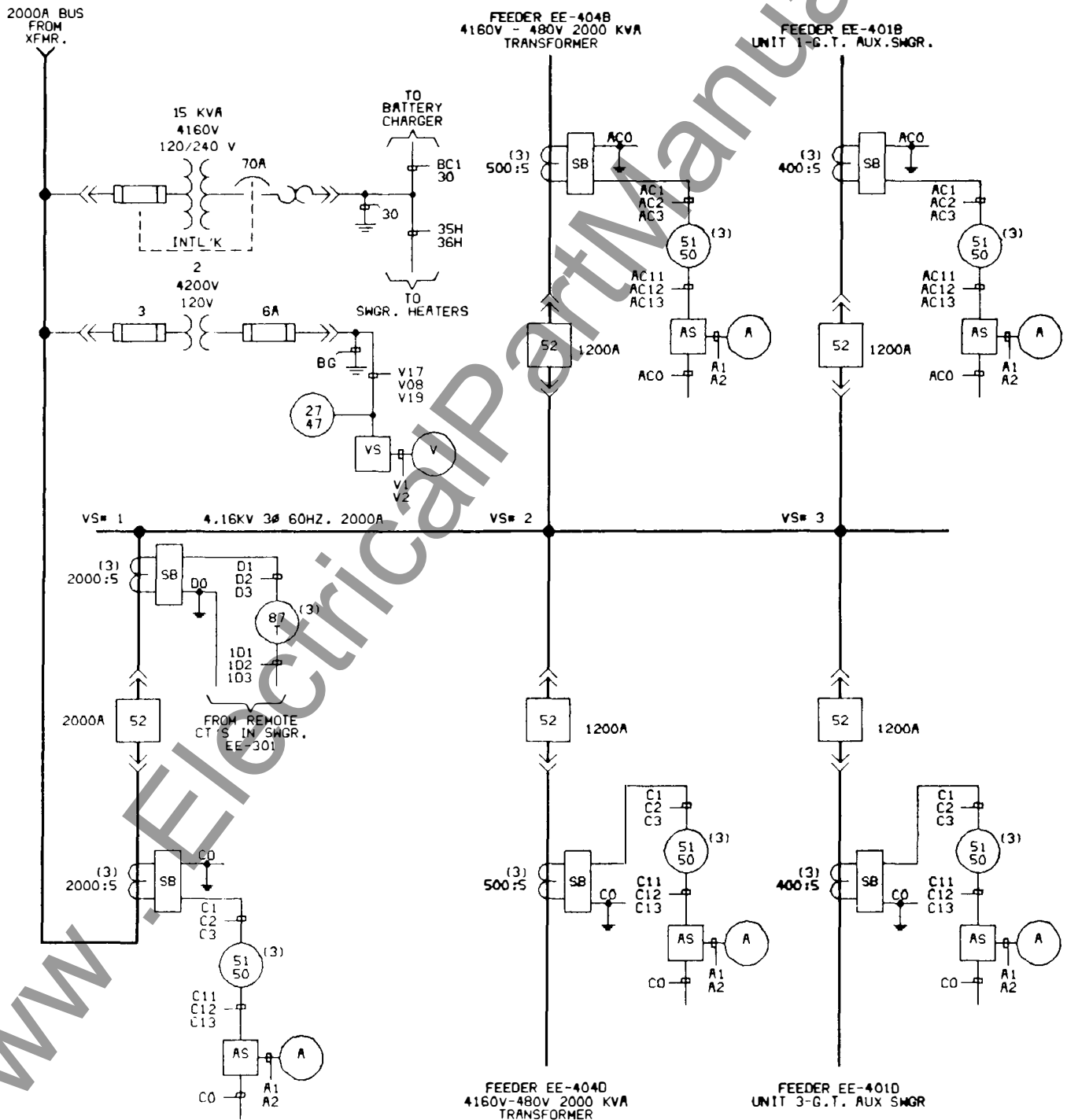

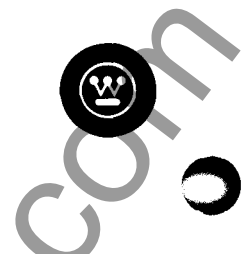

Type VacClad-W Medium Voltage Metal-Clad Switchgear

Table of Contents

Description, Application	2
Metal-Clad Switchgear Definition	2
Applicable Industry Standards	3
Design, Production Tests	3
Features	4
Typical Vertical Sections	6
Available Configurations	7
System Application	8
Surge Protection	14
Instrument Transformers	15
Control Equipment	16
Dimensions, Installation	19
Shipping, Receiving, Handling, Storage	20
Installation, Field Assembly	20
Weights	20
Standard Designs, Vertical Sections	21
How to Arrange, Select, Specify VacClad-W Switchgear	28
Typical Specifications	30

Description and Application

VacClad-W Metal-Clad Switchgear is an integrated assembly of drawout vacuum circuit breakers, bus, and control devices coordinated electrically and mechanically for medium voltage circuit protection. The Metal-Clad integrity provides maximum circuit separation and safety. Included are isolated grounded metal compartments, complete insulation of all conductors insuring that no live parts will be exposed by opening of a door. It is typically used on circuits involving feeder circuits, transmission lines, distribution lines and motors.

All major components are manufactured by Westinghouse, establishing one source of responsibility for the equipment and assuring high standards in quality, coordination, reliability and service.

VacClad-W Switchgear is available in voltage ratings of 4.76KV through 15KV and in nominal interrupting capacities of 250MVA (29kA), 350MVA (41kA), 500MVA (18kA and 41kA), 750MVA (28kA), 1000MVA (37kA) and for indoor or outdoor applications.

Metal-Clad Switchgear Definition

Metal-Clad Switchgear is an assembly of units characterized by the following features:

- The main interrupting device is removable and arranged with a mechanism for moving it physically between connected and disconnected positions. It is equipped with self-aligning and self-coupling primary and secondary disconnecting devices.
- The interrupting devices, buses, voltage transformers, and control power transformers, are completely enclosed by grounded metal barriers, which have no intentional openings between compartments. A metal barrier in front of the interrupting device ensures that when, in the connected position, no live parts are exposed by the opening of a door.
- All live parts are enclosed within grounded metal compartments.
- Automatic shutters cover primary circuit elements when the removable element is in the disconnected, test or removed position.
- Primary bus conductors and connections are covered with track-resistant insulating material throughout.
- Mechanical interlocks are provided to maintain a proper and safe operating sequence.
- Instruments, meters, relays, secondary control devices and their wiring are isolated, where necessary, by grounded metal barriers from all primary circuit elements.

www.electricalpanels.com



Type VacClad-W Medium Voltage Metal-Clad Switchgear

Applicable Industry Standards ANSI American National Standards Standard Institute

C37.010 Application guide for ac high-voltage circuit breakers rated on a symmetrical current basis

C37.100 Definitions for power switchgear

C37.04 Rating structure for ac high-voltage circuit breakers

C37.06 Preferred ratings for ac high-voltage circuit breakers rated on a symmetrical current basis

C37.07 Factors for reclosing service

C37.09 Test procedure for ac high voltage circuit breakers

C37.11 Power circuit breaker control

C37.20 Switchgear assemblies including metal-enclosed bus

① C37.20.2 Metal-Clad and Station-Cubicle switchgear

① C37.21 Application Guide for Metal-Enclosed Power Switchgear

① C37.55 Conformance Testing of Metal-Clad Switchgear

C37.24 Guide for evaluating the effect of solar radiation

NEMA National Electrical Manufacturers Association

SG-4 Power Circuit Breakers

SG-5 Power Switchgear Assemblies

International Electrotechnical Commission Recommendations

IEC 56.4 High Voltage AC Breakers

① Proposed

Design/Proof Tests

VacClad-W Metal-Clad switchgear meets applicable ANSI, IEEE, NEMA and IEC standards. The design criteria dictated that all tests demonstrate performance above the requirements of the standards. The ANSI test series is basic test criteria and includes interruption, BIL, dielectric, continuous current, mechanical life, and thermal and environmental conditions.

The design/proof testing of VacClad-W switchgear is the most extensive ever performed by Westinghouse, which has always maintained the highest standards for its Metal-Clad equipment.

Production Tests

Circuit Breaker

- Each breaker draw-out unit is checked for alignment with a master cell fixture that verifies all interfaces and interchangeability.

- All circuit breakers are operated over the range of minimum to maximum control voltage.

- Interrupter contact gap is factory set.

- One-minute dielectric test is performed on each breaker, per ANSI Standards.

- Final inspection and quality check.

Housing

- Master breaker fixture is inserted into each breaker cell to ensure alignment.

- One-minute dielectric test per ANSI Standards is applied to both primary and secondary circuits.

- Operation of wiring, relays, and other devices is verified by test.

- Final inspection and quality check.



Type VacClad-W Medium Voltage Metal-Clad Switchgear

Features

1. **Vacuum Interrupter Current Transfer Conductor**
The Westinghouse "Stiff-Flexible" design eliminates the need for a main conductor sliding contact and its costly maintenance.
2. **Breaker Rails**
The breaker and auxiliaries can be withdrawn on rails for inspection and maintenance without the need for a separate lifting device.
3. **Front Breaker Mechanism**
The stored energy mechanism is on the front of the breaker so the inspection or maintenance can be done with the breaker on its rails.
4. **Horizontal Drawout Circuit Breaker**
Type VCP-W breaker is a horizontal drawout design, which provides connect, test, and disconnect position.
5. **Automatic Shutters**
These steel shutters operate automatically when the circuit breaker is withdrawn, to protect workmen from accidental contact with the stationary primary contacts.
6. **Main Bus System**
The main bus has fluidized-bed, track-resistant epoxy insulation with plated joints and constant pressure washers.
7. **Current Transformers**
There is space for up to four current transformers per phase which are easily accessible from the front.
8. **Primary and Secondary Contacts**
All moving breaker contacts are self-aligning, have positive action, and are silver-plated.
9. **Metal Compartment Barriers**
All compartments are enclosed by grounded metal barriers.
10. **Barriers**
Barriers are breaker mounted.
11. **Breaker Wheels**
Breaker can be rolled on floor when removed from the structure.
12. **Auxiliary Compartment Shutter**
This shutter operates automatically when the auxiliary drawer is withdrawn to protect workmen from accidental contact with the stationary primary contacts.

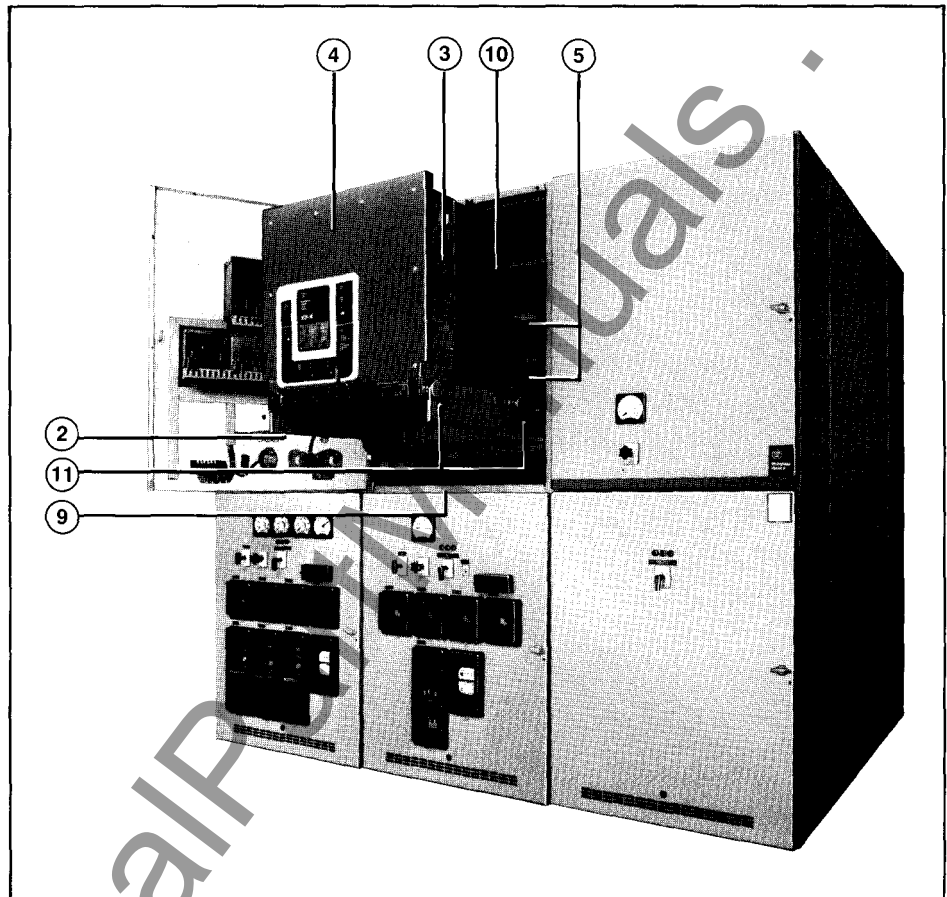



Type VacClad-W Medium Voltage Metal-Clad Switchgear

Features, Continued

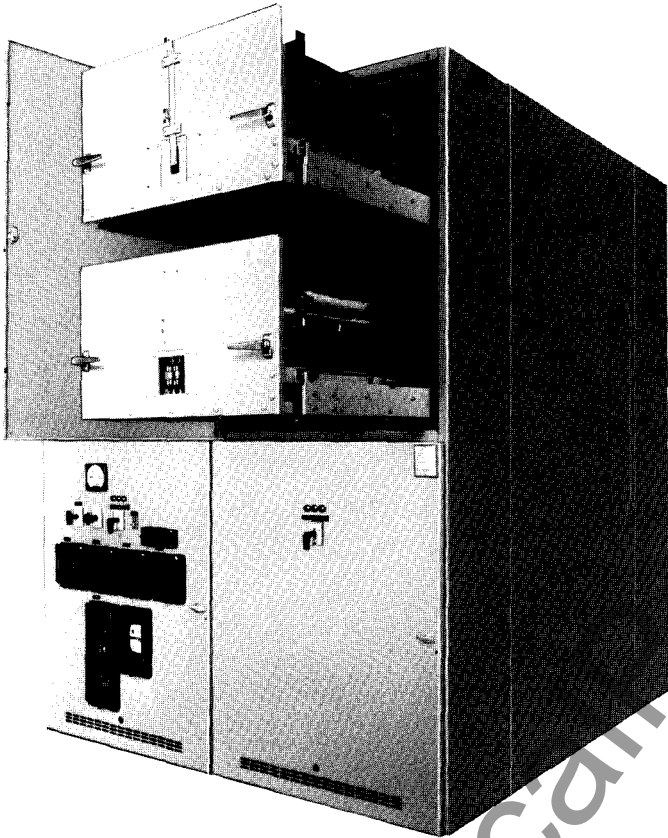

Front view showing auxiliary compartments withdrawn.



Rear view showing cable compartments.

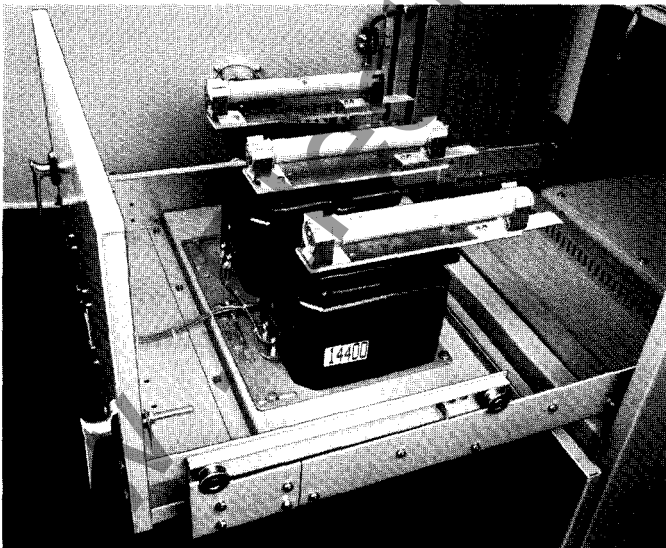

View of drawout voltage transformers.

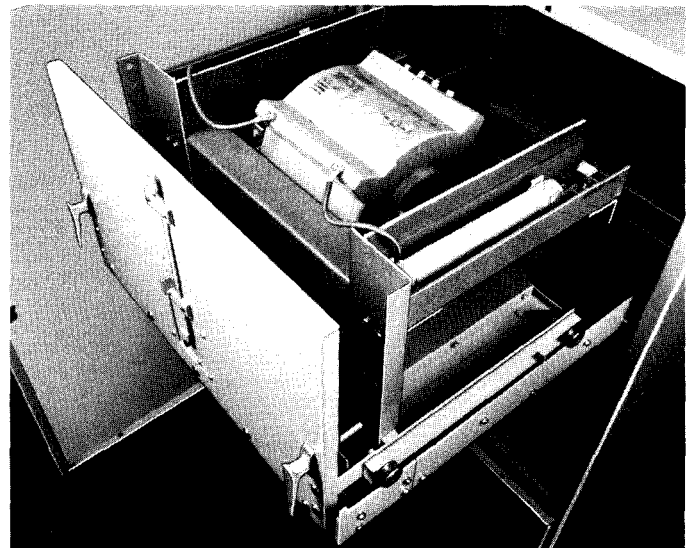

View of drawout control power transformer.



Type VacClad-W Medium Voltage Metal-Clad Switchgear

Typical Vertical Sections

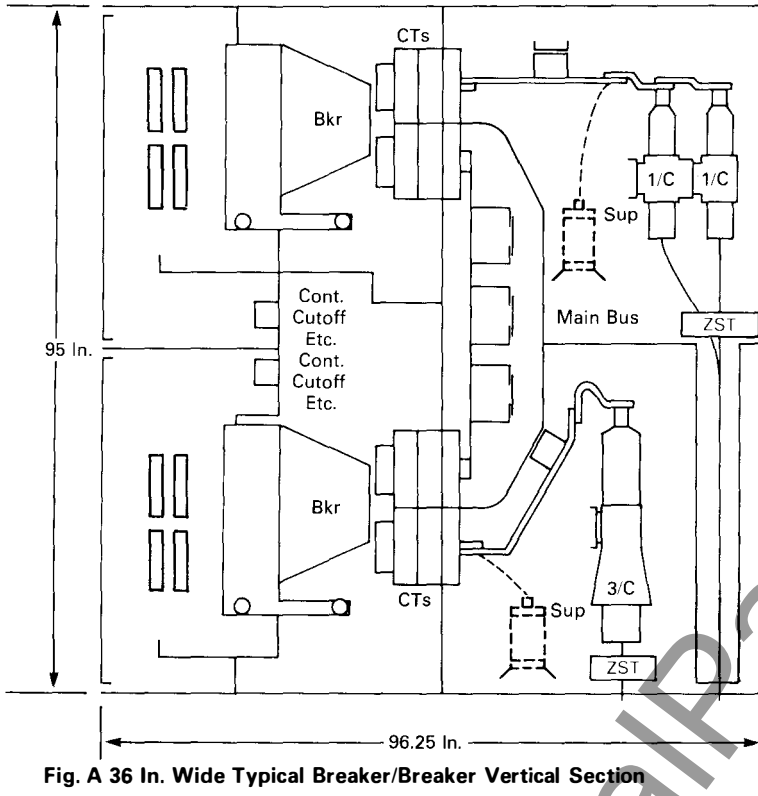

Fig. A 36 In. Wide Typical Breaker/Breaker Vertical Section

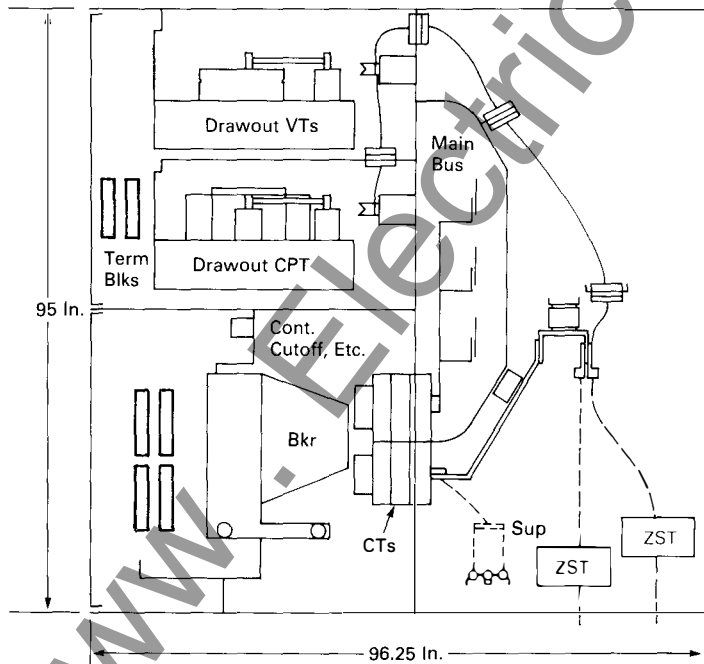

Fig. B 36 In. Wide Typical Auxiliary/Breaker Vertical Section

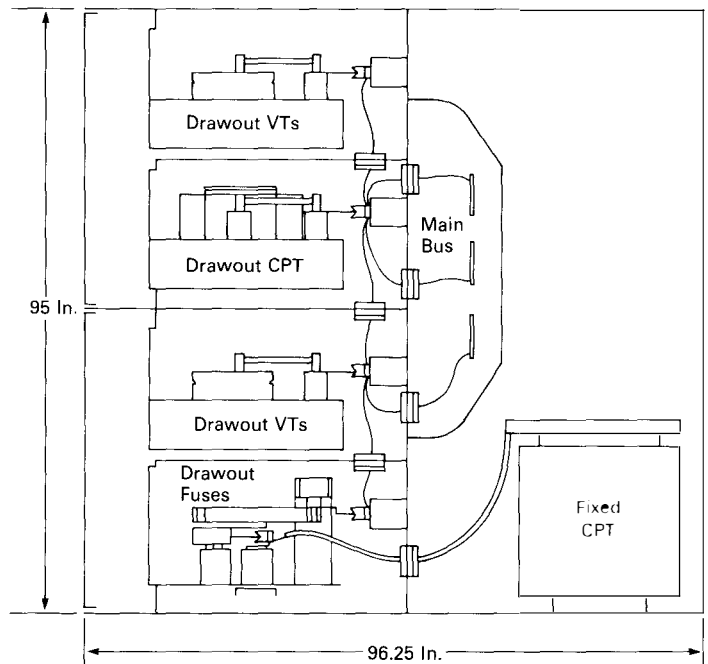

Fig. C 36 In. Wide Typical Auxiliary/Auxiliary Vertical Section



Type VacClad-W Medium Voltage Metal-Clad Switchgear

Available Configurations

1200A Breaker	1200A Breaker	1200A Breaker	D.O. Auxiliary	2000A Breaker
1200A Breaker	2000A Breaker	D.O. Auxiliary	1200A Breaker	D.O. Auxiliary
D.O. Auxiliary	Vented Auxiliary Compt. (Non-D.O.)	D.O. Auxiliary	2000A Breaker	3000A Breaker
2000A Breaker	3000A Breaker	D.O. Auxiliary	1200A Breaker	Blank Space
				Line Conn. D.O. Auxiliary



Type VacClad-W Medium Voltage Metal-Clad Switchgear

System Application

Table 1: Available Breaker Types Rated on Symmetrical Current Rating Basis, per ANSI Standards

Identification	Rated Values										Related Required Capabilities ^③			
	Nominal Voltage Class	Nominal 3-Phase MVA Class	Voltage		Insulation Level		Current		Rated Interrupting Time	Rated Permissible Tripping Delay	Rated Max. Voltage Divided By K	Current Values		
			Rated Max. Voltage	Rated Voltage Range Factor	Rated Withstand Test Voltage		Rated Continuous Current at 60 Hz	Rated Short Circuit Current (at rated Max. Kv) ^②				Maximum Sym. Interrupting Capability	3 Sec. Short-Time Current Carrying Capability	Closing and Latching Capability (Momentary) ^①
Circuit Breaker Type	Kv Class	MVA Class	E Kv rms	K	Low Frequency Kv rms	Impulse Kv Crest	Amperes	KA rms	Cycles	Sec.	E/K Kv rms	KA rms	KA rms	KA rms
VCP-W Vacuum Circuit Breaker														
50 VCP-W 250	4.16	250	4.76	1.24	19	60	1200 2000 3000	29	5	2	3.85	36	36	58 78 ^①
50 VCP-W 350	4.16	500	4.76	1.19	19	60	1200 2000 3000	41	5	2	4.0	49	49	78
75 VCP-W 500	7.2	500	8.25	1.25	36	95	1200 2000 3000	33	5	2	6.6	41	41	66
150 VCP-W 500	13.8	500	15	1.30	36	95	1200 2000 3000	18	5	2	11.5	23	23	37 58 ^①
150 VCP-W 750	13.8	750	15	1.30	36	95	1200 2000 3000	28	5	2	11.5	36	36	58 77 ^①
150 VCP-W 1000	13.8	1000	15	1.30	36	95	1200 2000 3000	37	5	2	11.5	48	48	77

Table 2: Available Breaker Types Rated on Symmetrical Current Rating Basis per IEC Standards

Circuit Breaker Type	Voltage Class, kV	Insulation Level		Rated Continuous Current, Amps	Rated Interrupting Current, kA ^⑤	Momentary Current, kA	
		Low Freq., kV	Impulse Withstand kV			3 Sec.	Peak
50 VCP-W 250	3.6	21	45	630 1250 2000	25	25	64
50 VCP-W 350	⑥	⑥	⑥	⑥	⑥	⑥	⑥
75 VCP-W 500	7.2	27	60	630 1250 2000	40	40	102
150 VCP-W 500	12	35	95	630 1250 2000	25	25	64
150 VCP-W 750	12	35	95	630 1250 2000	25	25	64
150 VCP-W 1000	●	⑥	⑥	⑥	⑥	⑥	⑥

① Non-Standard Breakers with High Momentary Rating available for Special Applications.
 ② For 3 phase and line to line faults, the sym interrupting capability at a Kv operating voltage

$$= \frac{E}{Kv} \text{ (Rated Short-Circuit Current)}$$
But not to exceed KI.
 Single line to ground fault capability at a Kv operating voltage

$$= 1.15 \frac{E}{Kv} \text{ (Rated Short-Circuit Current)}$$
But not to exceed KI.
 The above apply on predominately inductive or resistive 3-phase circuits with normal-frequency line to line recovery voltage equal to the operating voltage.

③ For Reclosing Service, the Sym. Interrupting Capability and other related capabilities are modified by the following reclosing capability factor obtained from the following formula:

$$R (\%) = 100 - \frac{C}{6} \left[(n - 2) + \frac{15 - T_1}{15} + \frac{15 - T_2}{15} + \dots \right]$$
 Where C = KA Sym. Interrupting Capability at the Operating Voltage but not less than 18.
 n = Total No. of Openings.
 T₁, T₂, etc. = Time interval in seconds except use 15 for time intervals longer than 15 sec.

Note: Reclosing Service with the standard duty cycle 0 + 15s + CO. Does not require breaker capabilities modified since the reclosing capability factor R = 100%.

④ Tripping may be delayed beyond the rated permissible tripping delay at lower values of current in accordance with the following formula:

$$T \text{ (seconds)} = Y \left[\frac{KI \text{ (K Times Rated Short-Circuit Current)}}{\text{Short-Circuit Current Through Breaker}} \right]^2$$
 The aggregate tripping delay on all operations within any 30 minute period must not exceed the time obtained from the above formula.
 ⑤ Standard duty cycle: O – 3 min. – CO – 3 min. – CO.
 ⑥ Not IEC recognized.



Type VacClad-W Medium Voltage Metal-Clad Switchgear

Application Quick Check Table

For application of circuit breakers in a radial system supplied from a single source transformer. Short-circuit duty was determined using E/X amperes and 1.0 multiplying factor for X/R ratio of 15 or less and 1.25 multiplying factor for X/R ratios in the range of 15 to 40.

Applications Above 3300 Feet

The rated one-minute power frequency withstand voltage, the impulse withstand voltage, the continuous current rating, and the maximum voltage rating must be multiplied by the appropriate correction factors below to obtain modified ratings which most equal or exceed the application requirements. Note that intermediate values may be obtained by interpolation.

Source Transformer MVA Rating		Kv Operating Voltage					Altitude (feet)	Correction Factor	
100%	0%	2.4	4.16	6.6	12	13.8		Current	Voltage
1	1.5	50 VCP-W 250 12 Ka	50 VCP-W 250 10.1 Ka	150 VCP-W 500 23 Ka	150 VCP-W 500 22.5 Ka	150 VCP-W 500 19.6 Ka	3,300 (and below)	1.00	1.00
1.5	2						5,000	0.99	0.95
2	2.5	50 VCP-W 250 36 Ka	50 VCP-W 250 33.2 Ka	75 VCP-W 500 41.3 Ka	150 VCP-W 750 35 Ka	150 VCP-W 750 30.4 Ka	10,000	0.96	0.80
2.5	3						3,75		
3	3.75	50 VCP-W 350 49 Ka	50 VCP-W 350 46.9 Ka	150 VCP-W 1000 46.3 Ka	150 VCP-W 1000 40.2 Ka				
3.75	5						7.5		
5	7.5	Breaker Type and Sym. Interrupting Capacity at the Operating Voltage							
7.5	10						10		
10	10								
10	12						12		
12	15								
15	20						15		
20	20								
20	25						20		
20	30								
20	50						20		

Ⓢ Transformer Impedance 6.5% or more, all other Transformer Impedances are 5.5% or more.

Load Current Switching

The following table of number of operations is a guide to normal maintenance for circuit breakers operated under usual service conditions for most repetitive duty applications including isolated capacitor bank switching and shunt reactor switching, but not for arc furnace switching. The numbers in the Table are consistent with ANSI C37.06 (1979).

Circuit Breaker Type	Continuous Current Rating Amperes	Number of Operations			
		Max. No. Operations Between Servicing	No Load Mechanical Duty	Continuous Current Switching	Inrush Current Switching
All VCP-W Vacuum Circuit Breakers	1200	2000	10,000	1000	750
	2000	2000	10,000	1000	750
	3000	1000	5,000	500	400

Servicing shall consist of adjusting, cleaning, lubricating, tightening, etc., as recommended by the circuit breaker instruction book.

Continuous current switching assumes opening and closing rated continuous current at rated maximum voltage with power factor between 80% leading and 80% lagging.

Inrush current switching assures a closing current equal to 600% of rated continuous current at rated maximum voltage with power factor of 30% lagging or less, and an opening current equal to rated continuous current at rated maximum voltage with power factor between 80% leading and 80% lagging.

In accordance with ANSI C37.06(1979), if a short-circuit operation occurs before the completion of the listed switching operations, maintenance is recommended and possible functional part replacement may be necessary, depending on previous accumulated duty, fault magnitude, and expected future operations.



Type VacClad-W Medium Voltage Metal-Clad Switchgear

Application on Symmetrical Current Rating Basis

Application Considerations

Westinghouse medium voltage metal-clad switchgear provides control and protection for generators, motors, transformers and all types of feeder circuits. In the usual application, the selection of the circuit breaker for the operating voltage, to carry the load current, and provide for the interruption of the available short-circuit, is of primary importance. The purpose of this application data is to aid in this selection.

It should be noted that for a particular application there may be other items of technical importance that require careful consideration. Also, requirements for special applications or unusual service conditions should be referred to the nearest Westinghouse Sales Office with details and a request for recommendations.

Rated Maximum Voltage

The kV operating voltage should not exceed the rated maximum voltage, E, in Table 1, since this is the upper limit for operation.

Rated Continuous Current

The continuous current rating of a circuit breaker is a maximum rating. The circuit breaker rating should always be in excess of the utilization equipment rating to provide for short time overload capability.

Transformer main breakers should be rated in excess of 125% of transformer full load amperes. Always consider forced cooled rating, possible future forced cooling and 12% additional capacity for 65° C rise rating when used.

Induction motor and synchronous motor starting breakers should be rated in excess of 125% of motor full load amperes.

Generator breakers should be in excess of 125% of generator full load current. Other factors such as increased capacity at 1.0 power factor, reduced voltage or low ambient temperature rating may have to be considered.

Capacitor bank feeder breakers should have a rating in excess of 135% of the bank full load current. This is due to a 0 to +15% manufacturing tolerance in capacitors, KVAR due to harmonic currents and possibility of up to 10% over-voltage.

Breaker Capacitor Switching Limits

Continuous Current Rating	Grounded Capacitor Bank	Ungrounded Capacitor Bank
1200A	890A	960A
2000A & 3000A	1180A	1280A

Interrupting Capability

Table 1 lists rated short-circuit current at rated voltage for the various available circuit breaker types. This is adjusted for the operating voltage to obtain the 3 phase symmetrical interrupting capability. This value is multiplied by 1.15 to obtain the single line to ground capability. Note that the 3 phase or single line to ground capabilities may not exceed KI, the maximum symmetrical interrupting capability.

Although these capabilities are expressed in sym. kilo-amperes, the circuit breaker shall be able to interrupt all values of asymmetrical as well as symmetrical short-circuit from a system having an X/R ratio of 15 or less.

Short-Circuit Duty

To check the breaker application from an interrupting standpoint, compare the interrupting capability at the operating voltage with the short-circuit duty determined for the point of application in the power system.

Table 2 lists multiplying factors depending upon the system X/R ratio, and the breaker rated interrupting time, to obtain the maximum short-circuit duty. If the maximum multiplying factor for the source of short-circuit current is used, it is not necessary to calculate the system X/R ratio. If the system X/R ratio is 15 or less, the multiplying factor is 1.0.

Short-Circuit Duty = E/X amperes (Max. Mult. Factor)

A closer check of the application requires calculation of the system X/R ratio. It is sufficiently accurate (on the conservative side) to neglect the resistance component when calculating the system reactance, X, and neglect the reactance component when calculating the system resistance, R. Use actual equipment data for important electrical devices wherever possible.

Typical data for various system components is included in Table 3 for estimating purposes.

System X/R ratio = $\frac{X_1}{R_1}$ for 3 phase faults

and = $\frac{2X_1 + X_0}{2R_1 + R_0}$ for single line to ground

faults, where X₁ and X₀ are positive and zero sequence reactances, R₁ and R₀ are positive and zero sequence resistances.

System X/R ratio so determined is used to obtain the E/X ampere multiplying factor from Table 2.

Short-Circuit Duty = E/X amperes (Mult. Factor Table 2).

E/X Amperes Calculations

Short circuit calculations usually consist of simple E/X computations:

3 phase fault

$$I_{3\phi} = \frac{E}{X}$$

single line to ground fault

$$I_{LG} = \frac{3E}{2X_1 + X_0}$$

Where E is line to neutral operating voltage, and reactances are ohms, per phase, line to neutral.

Computations are simplified by selection of a common base and using the per unit system of calculations:

3 phase fault

$$I_{3\phi} = \frac{I_B}{X}$$

single line to ground fault

$$I_{LG} = \frac{3 I_B}{2X_1 + X_0}$$

Where I_B is the base current in kilo-amperes and reactances are in per unit of the common base. Convenient per-unit system formulas:

$$I_B = \frac{\text{MVA Base}}{\sqrt{3} \text{ KV}}$$

$$\text{Base ohms} = \frac{\text{KV}^2}{\text{MVA}}$$

Where: KV = Line-to-Line Voltage

per unit X = $\frac{X}{\text{MVA base}}$

$$\text{or} = \frac{X}{I_B}$$

$$\text{or} = \frac{X \text{ ohms}}{\text{base ohms}} \quad \text{or} = \frac{X \text{ percent}}{100}$$

Where system is impedance grounded to limit the single line to ground fault to the 3 phase fault value or lower, only the 3 phase fault calculations are necessary.

Table 3 lists reactances quantity to be used for X for the various system components. Use actual data for important electrical devices wherever possible. Table 4 lists typical X/R ratio ranges and is included for estimating purposes.

The E/X amperes determined are in rms symmetrical kilo-ampere.

Momentary Duty

When there is motor contribution to the total short circuit, an additional calculation should be made to determine the momentary duty using the reactance quantities for momentary duty from Table 3.

Momentary Duty = 1.6 E/X Amperes

Compare momentary duty with close and latch capability or momentary rating listed in Table 1.



Type VacClad-W Medium Voltage Metal-Clad Switchgear

Table 2: Multiplying Factor for E/X Amperes (ANSI C37.010, 1979, Figs. 8, 9, 10)

System X/R	Type VCP-W Vacuum Circuit Breaker Rated Interrupting Time, 5 Cycle		
	Type of Fault		
Ratio	3 ϕ	LG	3 ϕ & LG
	Source of Short Circuit		
	Local		Remote
1	1.00	1.00	1.00
15 ^②	1.00	1.00	1.00
20	1.00	1.02	1.05
25	1.00	1.06	1.10
30	1.04	1.10	1.13
35	1.06	1.14	1.17
40	1.08	1.16	1.22
45	1.12	1.19	1.25
50	1.13	1.22	1.27
55	1.14	1.25	1.30
60	1.16	1.26	1.32
65	1.17	1.28	1.33
70	1.19	1.29	1.35
75	1.20	1.30	1.36
80	1.21	1.31	1.37
85			1.38
90	1.22	1.32	1.39
95			1.40
100	1.23	1.33	1.41
110	1.24	1.34	1.42
120	1.24	1.35	1.43
130	1.24	1.35	1.43

① Not necessary to calculate the system X/R ratio when Max. Multiplying Factor is used.

② Where system X/R ratio is 15 or less, the Multiplying Factor is 1.0.

Table 4: Typical System X/R Ratio Range (for estimating purposes)

Type of circuit	X/R Range
Remote generation thru other types of circuits such as transformers rated 10 MVA or smaller for each three phase bank, transmission lines, distribution feeders, etc.	15 or less
Remote generation connected thru transformers rated 10 MVA to 100 MVA for each three-phase bank, where the transformers provide 90 percent or more of the total equivalent impedance to the fault point.	15-40
Remote generation connected thru transformers rated 100 MVA or larger for each three-phase bank where the transformers provide 90 percent or more of the total equivalent impedance to the fault point.	30-50
Synchronous machines connected thru transformers rated 25 to 100 MVA for each three-phase bank.	30-50
Synchronous machines connected thru transformers rated 100 MVA and larger.	40-60
Synchronous machines connected directly to the bus or thru reactors.	40-120

Source of Short Circuit

Local

Application of breakers at generator voltage is local source. Also, local sources are considered to be where short circuit is fed predominantly from generators through:

a) Not more than one transformation, or

b) a per-unit reactance external to the generator which is less than 1.5 times the generator per-unit subtransient reactance on a common system MVA base.

① Max. Multiplying Factor
1.25 3 ϕ Fault
1.43 LG Fault

Remote

Most applications including station service auxiliaries are remote source. Remote sources are considered to be where the short circuit is fed predominantly from generators through:

a) two or more transformations, or

b) a per-unit reactance external to the generator that is equal to or exceeds 1.5 times the generator per-unit subtransient reactance on a common system MVA base.

① Max. Multiplying Factor
1.43 3 ϕ or LG Fault

Table 3: Reactance X for E/X Amperes

System Component	Reactance X Used for		Typical Values & Range on Component Base	
	Short-Circuit Duty	Momentary Duty	% Reactance	X/R Ratio
2 Pole Turbo Generator	X	X	9	80
			7-14	40-120
4 Pole Turbo Generator	X	X	14	80
			12-17	40-120
Hydro Gen. with Damper Wdgs. and Syn. Condensers	X	X	20	30
			13-32	10-60
Hydro Gen. without Damper Windings	75X	75X	30	30
			20-50	10-60
All Synchronous Motors	1.5X	1.0X	24	30
			13-35	10-60
Ind. Motors above 1000 HP, 1800 RPM and above 250 HP, 3600 RPM	1.5X	1.0X	25	30
All Other Induction Motors 50 HP and Above	3.0X	1.2X	15-25	15-40
			25	15
			15-25	5-20
Ind. Motors Below 50 HP and all Single Phase Motors	Neglect	Neglect		
Distribution System from Remote Transformers	X	X	as Specified or Calculated	15
Current Limiting Reactors	X	X	as Specified or Calculated	5-15
				80
				40-120
Transformers				
OA to 10 MVA, 69 Kv	X	X	5.5	10
			5-7	6-12
OA to 10 MVA, above 69 Kv	X	X	7.5	12
			7-11	8-15
FOA 12 to 30 MVA	X	X	10	20
			8-24	10-30
FOA 40 to 100 MVA	X	X	15	30
			8-35	20-40

Use transient reactance X'd for X for hydro generator without damper windings.

For other machines use subtransient reactance X''d for X.

For other system components use positive sequence reactance X¹ for X.



Type VacClad-W Medium Voltage Metal-Clad Switchgear

Application on Symmetrical Current Rating Basis

Example 1 — Fault Calculations

Type Breaker	E Max.	3 ϕ Sym. Interrupting Capability			Close & Latch or Momentary
		@ E. Max.	Max. KI	@ 4.16 Kv Oper. Voltage	
50VCP-W250	4.76	29 kA	36kA	$\left[\frac{4.76}{4.16} \right] (29) = 33.2 \text{ kA} \textcircled{2}$	58 kA $\textcircled{1}$
LG sym. Interrupting Capability					
		36 kA	1.15 (33.2) = 38.2 kA $\textcircled{3}$		

Note: Interrupting capabilities $\textcircled{2}$ and $\textcircled{3}$ at operating voltage must not exceed max. sym. interrupting capability KI

Check capabilities $\textcircled{1}$, $\textcircled{2}$ and $\textcircled{3}$ on the following utility system where there is no motor contribution to short circuit.

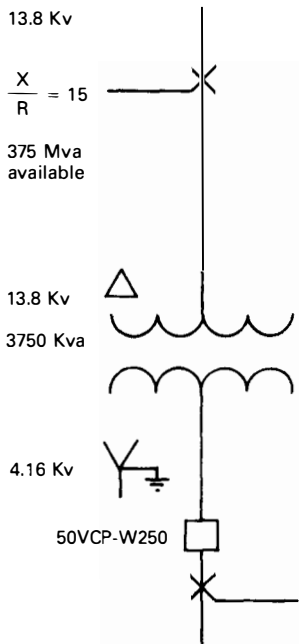

On 13.8 Kv System, 3.75 Mva Base

$$Z = \frac{3.75 \text{ Mva}}{375 \text{ Mva}} = .01 \text{ pu or } 1\%$$

$$Z^2 = X^2 + R^2 = R^2 \left(\frac{X^2}{R^2} + 1 \right)$$

$$R = \frac{Z}{\sqrt{\frac{X^2}{R^2} + 1}} = \frac{1}{\sqrt{226}} = \frac{1}{15.03} = .066\%$$

$$X = \frac{X}{R} (R) = 15 (.066) = .99\%$$

Transformer Standard 5.5% Impedance has a $\pm 7.5\%$ Manufacturing Tolerance

$$\text{Transformer } Z = \frac{5.50 \text{ Standard Impedance} - .41 (-7.5\% \text{ Tolerance})}{5.09\%}$$

From transformer losses R is calculated

$$R = \frac{24.2 \text{ Kw}}{3750 \text{ Kva}} = .0065 \text{ pu or } .65\%$$

$$\text{transformer } X = \sqrt{Z^2 - R^2} = \sqrt{(5.09)^2 - (.65)^2} = \sqrt{25.91 - .42} = \sqrt{25.48}$$

$$X = 5.05\%$$

	X	R	X/R
13.8 Kv System	.99%	.066%	15
Transformer	5.05	.65	8
System Total or	6.04% .0604 pu	.716% .00716 pu	9

For 3 Phase Fault

$$I_{3\phi} = \frac{E}{X} \text{ where } X \text{ is ohms per phase and } E \text{ is line to neutral voltage}$$

is line to neutral voltage

$$\text{or } I_{3\phi} = \frac{I_b}{X} \text{ where } X \text{ is per unit reactance}$$

I_b is base current

$$\text{Base current } I_b = \frac{3.75 \text{ Mva}}{\sqrt{3} (4.16 \text{ Kv})} = .52 \text{ kA}$$

$$I_{3\phi} = \frac{I_b}{X} = \frac{.52}{.0604} = 8.6 \text{ kA Sym.}$$

System $\frac{X}{R} = 9$ (is less than 15) would use

1.0 mult. factor for short-circuit duty, therefore, short-circuit duty is 8.6 kA sym. for 3 ϕ fault $\textcircled{2}$ and momentary duty is $8.6 \times 1.6 = 13.7 \text{ kA} \textcircled{1}$

For Line to Ground Fault

$$I_{LG} = \frac{3E}{2X_1 + X_0} \text{ or } = \frac{3I_b}{2X_1 + X_0}$$

For this system, X_0 is the zero sequence reactance of the transformer which is equal to the transformer positive sequence reactance and X_1 is the positive sequence reactance of the system.

Therefore,

$$I_{LG} = \frac{3(.52)}{2(.0604) + .0505} = 9.1 \text{ kA Sym.}$$

Using 1.0 mult. factor, short-circuit duty = 9.1 kA Sym. LG $\textcircled{3}$

The 50VCP-W250 breaker capabilities exceed the duty requirements and may be applied.

With this application, short cuts could have been taken for a quicker check of the application. If we assume unlimited short circuit available at 13.8 Kv and that Trans. $Z = X$

$$\text{Then } I_{3\phi} = \frac{I_b}{X} = \frac{.52}{.055} = 9.5 \text{ kA Sym.}$$

X/R ratio 15 or less mult. factor is 1.0 for short-circuit duty.

The short-circuit duty is then 9.5 kA Sym. $\textcircled{2}$, $\textcircled{3}$ and momentary duty is $9.5 \times 1.6 \text{ kA} = 15.2 \text{ kA} \textcircled{1}$.



Type VacClad-W Medium Voltage Metal-Clad Switchgear

Example 2 — Fault Calculations

All calculations on per unit basis. 7.5 Mva Base

$$\text{Base Current } I_b = \frac{7.5 \text{ Mva}}{\sqrt{3} \cdot 6.9 \text{ Kv}} = .628 \text{ Ka}$$

	X	R	X/R
13.8 Kv System			
$X = \frac{.628}{21} \frac{(6.9)}{(13.8)} = .015$.015	.001	15
Transformer	.055	.0055	10
Total Source Transf.	.070 pu	.0065 pu	11

3000 Hp Syn. motor

$$X = .20 \frac{(.628)}{.197} = .638 \text{ pu at 7.5 Mva base}$$

2500 Hp Ind. Motor

$$X = .25 \frac{(.628)}{(.173)} = .908 \text{ pu at 7.5 Mva base}$$

$$I_{3\phi} = \frac{E}{X} \text{ or } = \frac{I_b}{X} \text{ where X on per unit base}$$

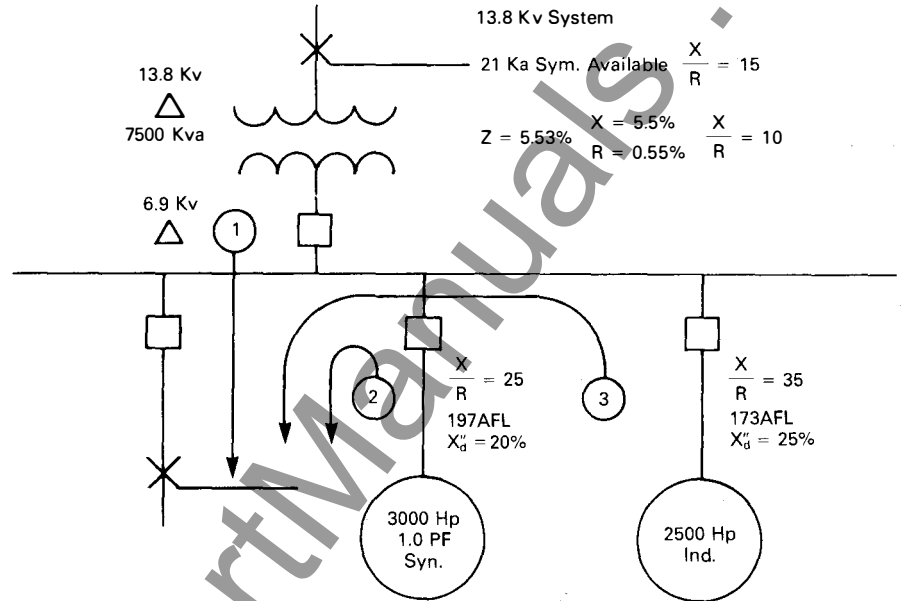

Source of Short Circuit Current	Interrupting E/X Amperes	Momentary E/X Amperes	X/R	X(1)/R(X)	1/R
① Source Transf.	$\frac{.628}{.070} = 8.971$	$\frac{.628}{.070} = 8.971$	11	$\frac{11}{.070}$	= 157
② 3000 HP Syn. Motor	$\frac{.628}{(1.5) .638} = .656$	$\frac{.628}{.638} = .984$	25	$\frac{25}{.638}$	= 39
③ 2500 HP Ind. Motor	$\frac{.628}{(1.5) .908} = .461$	$\frac{.628}{.908} = .691$	35	$\frac{35}{.908}$	= 39

$$I_{3\phi} = \frac{10.088}{10.1} \text{ Ka} \quad \text{or} \quad \frac{10.647 \times 1.6}{17.0} \text{ KA Momentary Duty}$$

Total 1/R = 235

$$\text{Total X} = \frac{I_b}{I_{3\phi}} = \frac{.628}{10.1} = .062$$

$$\text{System } \frac{X}{R} = .062 (235) = 14.5 \text{ is Mult. Factor 1.0 from Table 2.}$$

Short circuit duty = 10.1 Ka

Type Breaker	E Max.	3φ Sym. Interrupting Capability			Close & Latch or Momentary
		⊕ E. Max.	Max. KI	⊕ 6.9 Kv Oper. Voltage	
75VCP-W500	8.25	33 Ka	41 Ka	$\frac{8.25}{6.9} (33) = 39.5 \text{ Ka}$	66 KA
150VCP-W500	15	18 Ka	23 Ka	$\frac{15 (18)}{6.9} (39.1) = 23 \text{ Ka}$ (But not to exceed KI)	37 KA

Either breaker could be properly applied, but price will make the type 150VCP-W500 the more economical selection.



Type VacClad-W Medium Voltage Metal-Clad Switchgear

Application on Symmetrical Current Rating Basis, *Continued*

Example 3—Fault Calculations

Check breaker application on generator bus where

Each generator is 7.5 Mva, 4.16 Kv 1040 amperes full load, $I_b = 1.04$ Ka

Sub transient reactance $X_d'' = 11\%$ or, $X = 11$ pu

Gen $\frac{X}{R}$ ratio is 30

$$\frac{1}{X_s} = \frac{1}{X} + \frac{1}{X} + \frac{1}{X} = \frac{3}{X} \text{ and } \frac{1}{R_s} = \frac{1}{R} + \frac{1}{R} + \frac{1}{R} = \frac{3}{R}$$

$$\text{or } X_s = \frac{X}{3} \text{ and } R_s = \frac{R}{3} \text{ Therefore, System } \frac{X_s}{R_s} = \frac{X}{R} = \text{Gen } \frac{X}{R} = 30$$

Since generator neutral grounding reactors are used to limit the I_{LG} to $I_{3\phi}$ or below, we need only check the $I_{3\phi}$ short-circuit duty.

$$I_{3\phi} = \frac{I_b}{X} + \frac{I_b}{X} + \frac{I_b}{X} = \frac{3I_b}{X} = \frac{3(1.04)}{.11} = 28.4 \text{ Ka Sym. E/X amperes}$$

Table 2 System $\frac{X}{R}$ of 30 is Mult. factor 1.04

Short-circuit duty is $28.4 (1.04) = 29.5$ Ka Symmetrical.

Type Breaker	E Max.	3 ϕ Sym. Interrupting Capability		
		(α E Max.	Max. KI	(α 4.16 Kv Oper. Voltage
50VCP-W250	4.76	29 Ka	36 Ka	$\frac{4.76}{4.16} (29) = 33.2$ Ka

The 50VCP-W250 breaker could be applied.

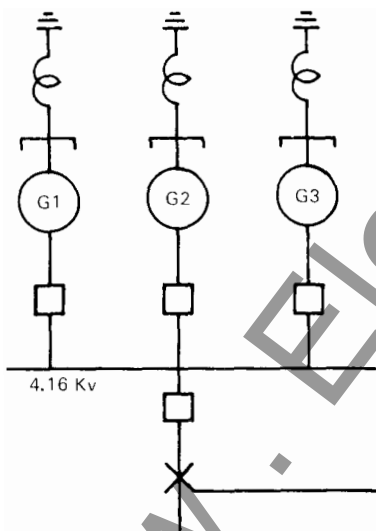

Surge Protection

VacClad-W metal clad switchgear is applied over a broad range of circuits, and is one of many types of equipment in the total system. The distribution system can be subject to voltage transients caused by lightning or switching surges.

Recognizing this phenomenon, the industry has developed standards to provide guidelines for application of electrical equipment, which should be used in the design of distribution systems independent of the breaker interrupting medium. These standards are:

IEEE 288 (1969) - ANSI C37.92 (1972)-
IEEE Guide for Induction Motor Protection.

IEEE 242 - 1975 (Buff Book)
IEEE Recommended Practice for Protection and Co-ordination of Industrial and Commercial Power Supplies.

IEEE 141 - 1976 (Red Book)
Recommended Practices for Electric Power Distribution in Industrial Plants.

ANSI C37.20 (IEEE-27)
Switchgear assemblies including metal-enclosed bus.

In general, if the BIL of the system is equal to the BIL of VacClad-W metal clad switchgear, no protection is required against switching surges; however, rotating apparatus rarely meets this criterion. For circuits exposed to lightning, protection is recommended in line with standard practices.

With the wide range of applications, not all circuits require surge protection. Therefore, VacClad-W metal clad switchgear does not include any surge protection as standard. The user exercises the options as to the type of protection deemed necessary, depending on the individual circuit characteristics and cost considerations.

The following recommendations are outlined to provide guidelines of minimum surge protection for metal clad switchgear and the associated system equipment:

1. Lightning - Standard lightning protection: arresters. (Refer to Typical Lightning Arrester Application, Page 15.)
2. Switching surge protection:
 - a. Liquid filled transformer — no surge protection.
 - b. Dry type transformers:
 - 15 Kv - 95 Kv BIL - no surge protection required.
 - 7.5 Kv - 95 Kv BIL - no surge protection required.
 - 5 Kv - 60 Kv BIL - no surge protection required.



Type VacClad-W Medium Voltage Metal-Clad Switchgear

Surge Protection, *Continued*

For all other voltages/BIL ratings for dry type transformers, surge protection (arresters or capacitors) is recommended at the transformer terminals, in line with established practices. Metal oxide surge absorbers can be supplied in VacClad-W switchgear as an alternate to the above.

- c. Motors — Surge capacitors at the motor terminals (and surge arresters where appropriate).
- d. Generators — Surge capacitors and station class surge arresters at machine terminals.
- e. Switching overhead lines and underground cables — no surge protection required.
- f. Capacitor Switching — no surge protection required.
- g. Shunt reactor switching — Three phase 15 Kv dry-type reactors less than 9 MVA require surge protection at the reactor's terminals.

Metal-oxide surge absorbers limit the magnitude of prospective overvoltage, but are ineffective in controlling the rate-of-rise of fast transients which surge capacitors do control. Surge capacitor values recommended are: 0.25 uf on 15 Kv systems, and 0.5 uf on 5 Kv and 7.5 Kv. Reliability of surge capacitors is high, since they are operated at only 50% of the stress of conventional power capacitors. The combination of conservative design and high final test level at 7 times rated voltage for 10 seconds assures the long life and established reliability of surge capacitors. The new metal oxide surge absorbers/arresters are recommended, and this latest advance in arrester design assures better performance and high reliability of this component utilized in surge protection schemes.

These application guidelines for VacClad-W metal clad switchgear were established after extensive analysis of medium voltage power systems.

Typical Lightning Arrester Application

Operating Voltage Kv	Impedance	
	Grounded or Ungrounded System	Solidly Grounded System
2.4	3 Kv	3 Kv
4.16	6 or 4.5 Kv	3 Kv
6.9	9 or 7.5 Kv	6 Kv
12.0	15 Kv	9 Kv
13.8	15 Kv	12 Kv

The location of arresters at the junction of cables connected to exposed line may also protect equipment. The following table shows typical maximum cable lengths which can be protected by riser pole arresters, based on typical assumed system parameters and on the full range of known arrester types and makes. Where cable length to equipment exceeds the maximum listed, it is recommended that arresters also be located at the equipment.

Suggested maximum cable length, in feet, between riser pole arresters and protected equipment:

Lightning Arrester Rating	Station Type Arrester	Intermediate Type	Distribution Type
To 60 Kv BIL Metal-Clad Switchgear			
3 Kv	NL	NL	NL
4.5 Kv	NL	NL	X
6 Kv	NL	NL	70
To 95 Kv BIL Metal-Clad Switchgear			
6 Kv	NL	NL	NL
7.5 Kv	NL	NL	X
9 Kv	NL	NL	160
12 Kv	NL	240	70
15 Kv	110	80	S
To 60 Kv BIL Liquid or Gas-Filled Transformer			
3 Kv	NL	NL	NL
4.5 Kv	NL	NL	X
6 Kv	NL	NL	NL
To 75 Kv BIL Liquid or Gas-Filled Transformer			
3 Kv	NL	NL	NL
6 Kv	NL	NL	NL
7.5 Kv	NL	NL	X
9 Kv	NL	NL	90
To 95 Kv BIL Liquid or Gas-Filled Transformer			
9 Kv	NL	NL	NL
12 Kv	NL	NL	120
15 Kv	NL	130	70

NL means no limit to cable length
 X means not applicable
 S means cable length too short to consider

Instrument Transformers

Instrument transformers are used to protect personnel and secondary devices from high voltage and permit use of reasonable insulating levels and current carrying capacity in relays, meters and instruments. The secondaries of standard instrument transformers are rated at 5 amperes and/or 120 volt, 60 hertz.

Voltage Transformers

Selection of the ratio for voltage transformers is seldom a question since the primary rating should be equal to or higher than the system line to line voltage. The number of potential transformers per set and their connection is determined by the type of system and the relaying and metering required.

The 3 phase, 3 wire system with 2 element watt-hour meters would require a set of two line to line voltage transformers. If line to ground potential is also required for a directional ground relay, then a set of three line to ground voltage transformers could be used to provide both line to line potential for the 2 element watt-hour meter and line to ground potential for the ground relay.

Ground detection lights or relays for the ungrounded system requires three line to ground voltage transformers and a separate set is usually recommended for this purpose.

The 3 phase, 4 wire, solidly grounded system usually requires three line to ground voltage transformers for 2-1/2 or 3 element metering.

Where synchronizing of generators or systems is involved, it is recommended that only line to line potential be used.

Current Transformers

The current transformer ratio is generally selected so that the maximum load current will read about 70 percent full scale on a standard 5 ampere coil ammeter. Therefore, the current transformer primary rating should be 140 to 150 percent of the maximum load current.

Maximum system fault current can sometimes influence the current transformer ratio selection since the connected secondary devices have published one second ratings.

The zero-sequence current transformer is used for sensitive ground fault relaying or self-balancing primary current type machine differential protection. The zero-sequence current transformer is available with a nominal ratio of 50-5 and available opening size for power cables of 6.5 inches.

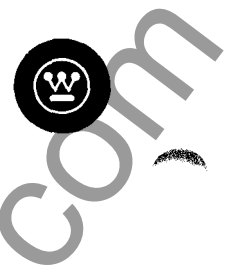

Type VacClad-W Medium Voltage Metal-Clad Switchgear

Standard Voltage Transformers • 60 Hertz

Rating	2400	4200	4800	7200	8400	12000	14400
Ratio	20-1	35-1	40-1	60-1	70-1	100-1	120-1

Switchgear Voltage Transformers — ANSI Accuracy

KV Class	Kv BIL	Max. Number Per Set and Connection	Standard Ratio's	120 Volts at Burden			69.3 Volts at Burden			Thermal Rating 55° C Conn.	Volt-amp
				W, X, Y	Z	W, X	Y	Z			
5	60	2LL or 3LG	20, 35, 40	0.3	1.2	0.3				LL LG LG [Ⓢ]	700 400 700
7.5 & 15	95	2LL or 3LG	35, 40, 60, 70, 100, 120	0.3	0.3	0.3	0.3	1.2		LL LG LG [Ⓢ]	1000 550 1000

① For solidly grounded 4160 volt system only or any type 2400 volt system.
 ② For solidly grounded system only.
 LL = Line to Line connection.
 LG = Line to Ground connection.

The minimum number of current transformers for circuit relaying and instruments is three current transformers, one for each phase or two phase connected current transformers and one zero-sequence current transformer. Separate sets of current transformers are required for differential relays.

The minimum pickup of a ground relay in the residual of three phase connected current transformers is primarily determined by the current transformer ratio. The relay pickup can be reduced by adding one residual connected auxiliary current transformer. This connection is very desirable on main incoming and tie circuits of low resistance grounded circuits.

Standard accuracy current transformers are normally more than adequate for most standard applications.

Standard Current Transformers • 55°C Ambient

Current Ratings	Metering Accuracy Classification			Relaying Accuracy
	60 Hz Standard	Burden	Burden	
Amperes	B 0.1	B 0.5	B 2.0	Accuracy
50:5	1.2			C10
75:5	1.2			C20
100:5	1.2			C10
150:5	.6	2.4		C20
200:5	.6	2.4		C20
250:5	.6	2.4		C20
300:5	.6	2.4	2.4	C20
400:5	.3	1.2	2.4	C50
500:5	.3	.3	2.4	C50
600:5	.3	.3	2.4	C100
800:5	.3	.3	1.2	C100
1000:5	.3	.3	.3	C100
1200:5	.3	.3	.3	C200
1500:5	.3	.3	.3	C200
2000:5	.3	.3	.3	C200
2500:5	.3	.3	.3	C200
3000:5	.3	.3	.3	C200
4000:5	.3	.3	.3	C200
4000:4	.3	.3	.3	C200

① Accuracy meets or exceeds accuracy in proposed ANSI C37.20.2.

Control Equipment

Circuit Breaker Control

The VCP-W circuit breaker has a motor charged spring type stored energy closing mechanism. Closing the breaker charges accelerating springs. Protective relays or the control switch will energize a shunt trip coil to release the accelerating springs and open the breaker. This requires a reliable source of control power for the breaker to function as a protective device.

For ac control, a capacitor trip device is used with each circuit breaker shunt trip and each WL-2 lockout relay to insure that energy will be available for tripping during fault conditions. A control power transformer is required on the source side of each incoming line breaker. Closing bus tie or bus sectionalizing breakers will require automatic transfer of control power. This control power transformer may also supply other Ac auxiliary power requirements for the switchgear.

Dc control would require a dc control battery, battery charger and an ac auxiliary power source for the battery charger. The battery provides a very reliable dc control source, since it is isolated from the ac power system by the battery charger. However, the battery will require periodic routine maintenance and battery capacity is reduced by low ambient temperature.

Any economic comparison of ac and dc control for switchgear should consider that the ac capacitor trip is a static device with negligible maintenance and long life, while the dc battery will require maintenance and replacement at some time in the future.

VCP-W Breaker Stored Energy Mechanism Control Power Requirements

Rated Control Voltage	Spring Charge Motor		Close or Trip Amperes	Voltage Range		Ind. Light Amperes
	Run Amperes	Time Sec.		Close	Trip	
48 V Dc	9.0	6	16	38-56	28-56	.035
125 V Dc	4.0	6	7	100-140	70-140	.035
250 V Dc	2.0	6	4	200-280	140-180	.035
120 V Ac	4.0	6	6	104-127	104-127	.035
240 V Ac	2.0	6	3	208-254	208-254	.035

Control Power Transformers • Disconnect Type • 1 Phase • 60 Hertz

Primary Volts ^①			Secondary Volts	Kva	Kv Class
+7½%	Rated	-7½%			
2580	2400	2220	240/120	5, 10, 15	5
4470	4160	3850	240/120	5, 10, 15	5
5160	4800	4400	240/120	5, 10, 15	5
7740	7200	6680	240/120	5, 10, 15	15
12900	12000	11100	240/120	5, 10, 15	15
14300	13800	12300	240/120	5, 10, 15	15

① Line to line connection only available.



Type VacClad-W Medium Voltage Metal-Clad Switchgear

Typical Applications		Permissive Local Control		General Auxiliary Switch applications, Indicating lights, Alarm, Supv. Control Indicator, Field application, etc.									
		Start-run Breaker Interlocking		Capacitor Trip Recloser	Interlocking to prevent Parallel Operation of Breakers Motor Space Heaters			Start-run Breaker Interlocking					
Type Auxiliary Switch or Device (supplied only when required.)		TOC Switch Shown for Breaker in Test Position		Breaker Auxiliary Switch Shown for Breaker in Open Position		TOC and Auxiliary Switch		MOC Switch Operating Position Shown for Breaker in Open Position		MOC Switch Operating and Test Position Shown for Breaker in Open Position		SG or MG6 Auxiliary Relay Note ①	
Breaker Condition													
Operating Position	Close	X		X		X		X		X		X	
	Open	X			X		X	X	X		X		X
Test Position	Close		X	X			X		X	X		X	
	Open		X		X		X	X	X		X		X
Withdrawn			X				X		X		X		X

① MOC Switch preferred unless scheme is fail safe on coil failure.
X indicates switch contact or circuit closed.

Auxiliary Switches

Optional circuit breaker and cell auxiliary switches are available where needed for interlocking or control of auxiliary devices. Typical applications and operation are described in the following table.

Auxiliary switch contacts from the circuit breaker mechanism are limited in number by the breaker control requirements usually to one 'a' and two 'b' contacts for ac control or two 'a' and two 'b' contacts for dc control.

When additional auxiliary contacts are needed, the optional auxiliary relay or mechanism operated cell (MOC) switch is used. Three types of MOC switches are available:

- (a) operates with breaker in connected position only
- (b) operates with breaker in connected position and test position
- (c) operates with breaker in connected position but operates with breaker in test position only if so manually selected.

The optional truck operated cell (TOC) switch operates when the circuit breaker is levered into or out of the operating position.

Interrupting Capacity Auxiliary Switch Contacts

Type Auxiliary Switch	Continuous Current Amperes	Control Circuit Voltage				
		120 Ac	240 Ac	48 Dc	125 Dc	250 Dc
Non-inductive circuit interrupting capacity in amperes						
Breaker Auxiliary Switch	20	20	20	15	10	5
TOC	20	20	20	15	10	5
MOC Auxiliary Switch	20	20	20	15	10	5
Inductive circuit interrupting capacity in amperes						
Breaker Auxiliary Switch	20	15	10	15	10	5
TOC Auxiliary Switch	20	15	10	15	10	5
MOC Auxiliary Switch	20	15	10	15	10	5

Auxiliary switch contacts are primarily used to provide interlocking in control circuits, switch indicating lights, auxiliary relays or other small loads. Suitability for switching remote auxiliary devices, such as motor heaters or solenoids, may be checked with the interrupting capacity listed in the following table. Where higher interrupting capacities are required, an interposing contactor should be specified.



Type VacClad-W Medium Voltage Metal-Clad Switchgear

Supplemental Devices

● Ground and Test Device

The ground and test device is a drawout element that may be inserted into a Metal-Clad Switchgear housing in place of a circuit breaker to provide access to the primary circuits to permit the temporary connection of grounds or testing equipment to the high voltage circuits. High potential testing of cable or phase checking of circuits are typical tests which may be performed. The devices are insulated to suit the voltage rating of the switchgear and will carry required levels of short circuit current.

Before using ground and test devices it is recommended that each user develop detailed operating procedures consistent with safe operating practices. Only qualified personnel should be authorized to use ground and test devices.

Manual ground and test devices are available. These devices include six studs for connection to primary circuits. On the manual device, selection and grounding is accomplished by cable connection.

Standard accessories:

- 1 - test jumper
- 1 - levering crank
- 1 - maintenance tool
- 1 - lifting yoke
- 1 - transport dolly (optional)
- 1 - portable lifter (optional)
- 1 - test cabinet (optional)
- 1 - set of rails
- 1 - set of rail clamps

Dimensions (Inches) and Installation Elevations

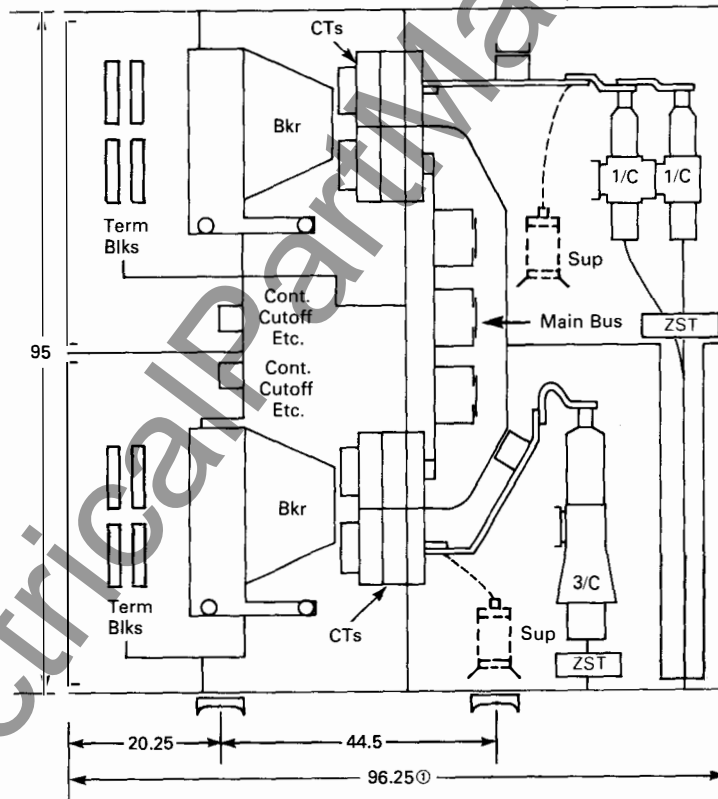
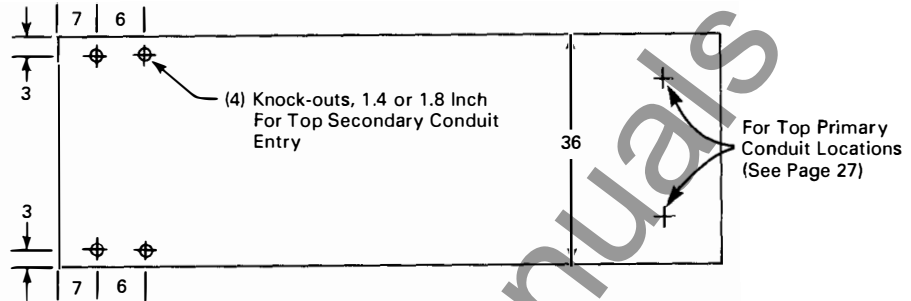

① 86.25 In. depth available in indoor for certain configurations.

Typical Indoor Elevation

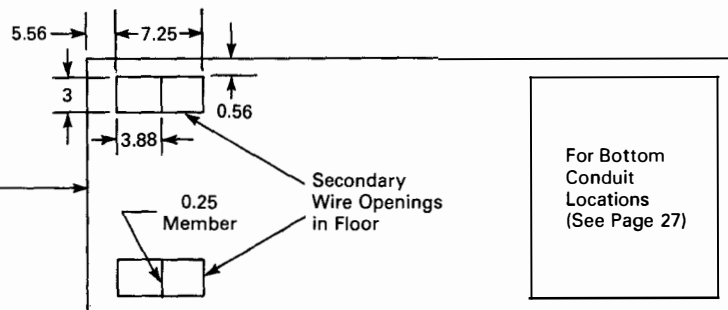

Typical Indoor Base Plan



Type VacClad-W Medium Voltage Metal-Clad Switchgear

Dimensions (Inches) and Installation, *Continued*

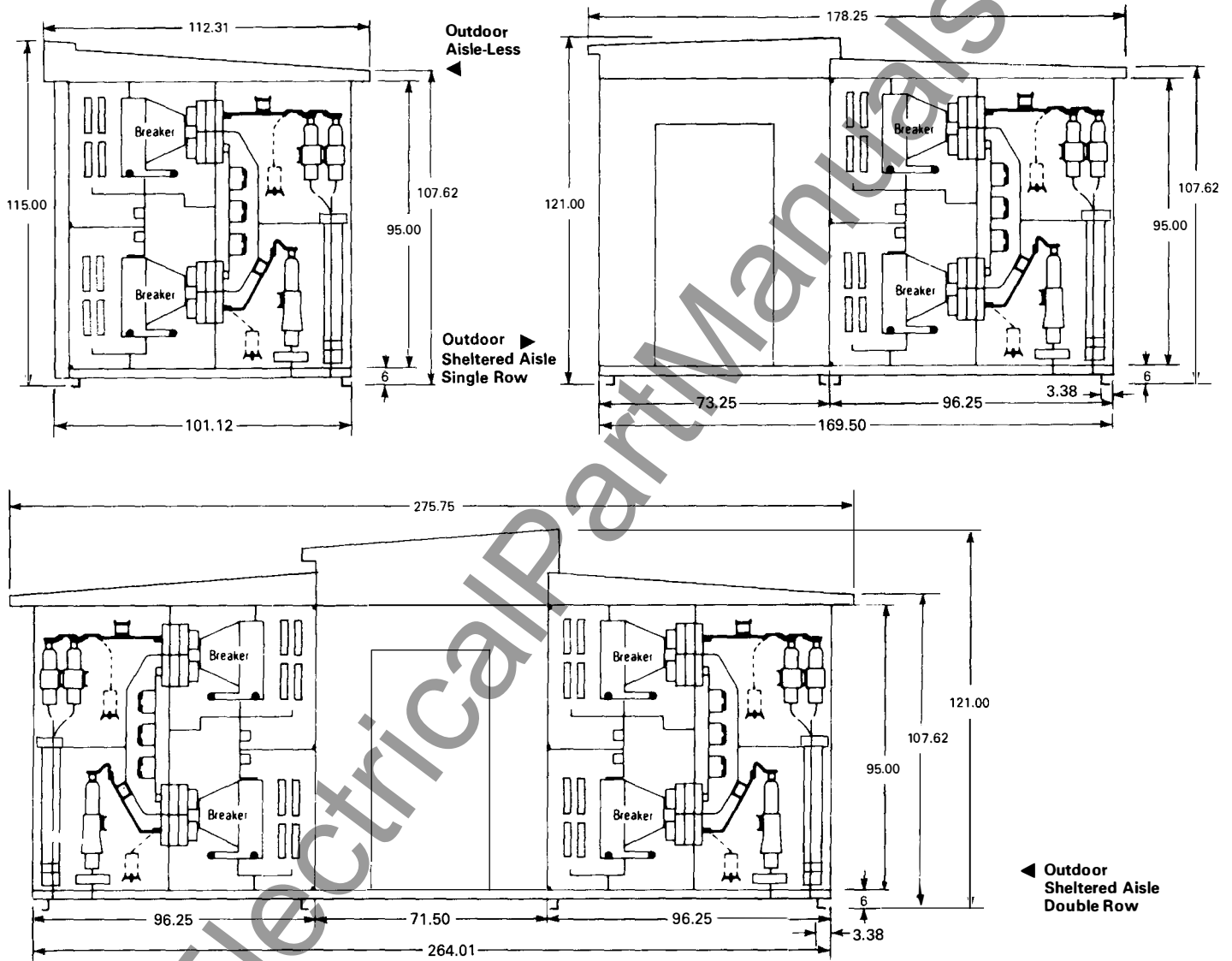

Dimensions, Inches

Note: Dimensions not to be used for construction. These shown are for reference only. Consult Westinghouse for exact dimensions.



Type VacClad-W Medium Voltage Metal-Clad Switchgear

Shipping and Receiving

VacClad-W metal-clad switchgear is shipped in groups of one or more units. Each group is designed and braced to withstand shipment by truck, rail, or ship. Indoor groups are bolted to skids and enclosed in a protective covering. Because of their structural base, outdoor groups do not need skids. For sheltered-aisle a protective covering is located across the front of each shipping group. Aisle-less gear is protected by its own weatherproof enclosure. VCP-W circuit breakers, accessories, and installation materials are packed and crated separately. Appendages such as bus runs and synchronizing panels and large internal equipment may also be packed and crated separately. When received, the purchaser should check the material against the shipping list. If loss or damage is discovered, file claims with the transportation company and notify the nearest Westinghouse representative.

Handling

VacClad-W Metal-Clad Switchgear is equipped for handling by crane. In addition, it is provided with shipping braces and jack supports. It is recommended that the groups be lifted into position by crane. However, if no crane is available they may be skidded into place on rollers using jacks to raise and lower the group.

Type VCP-W breakers are crated so as to be handled by crane or industrial "fork" truck. After uncrating, breakers may be lifted by crane.

Storing

Switchgear which cannot be installed and put into service immediately must be stored so as to maintain the equipment in a clean and dry condition. Storage in a heated building is recommended. If stored outdoors, special precautions must be taken: indoor switchgear must be covered and temporary heating equipment installed, outdoor switchgear must be supplied with temporary power for operation of the space heaters.

Installation and Field Assembly

Westinghouse VacClad-W switchgear is factory-tested and factory-assembled from accurately tooled parts upon true and level bedplates. A minimum of installation and field assembly time will be required if the procedures described on the drawings and in the instructions are adhered to.

The foundation for indoor switchgear should consist of rugged steel channels imbedded in a concrete floor. The steel channels must be flat, level, and in a true plane with each other. The finished floor must be in a true plane with the steel channels and must not project above the level of the steel channels.

The foundation for outdoor switchgear may be a concrete pad, or footers placed parallel with the length of the line-up. For any condition, the aisle-less switchgear requires a reasonably level and smooth pad for breaker drawout. The integral base furnished with outdoor switchgear should be supported in a level and true plane.

Field assembly of the outdoor aisle and of some weather-proofing is required. These parts are standardized and tool-made to simplify and expedite their assembly. The details of assembly are described in the job instruction book and associated drawings.

Typical Weights in Pounds Assemblies (Less Breakers)

Type of Vertical Section	Main Bus Rating Amps	Indoor	Aisle-less	Sheltered-Aisle Including Aisle	
		Lbs	Lbs	Single Row (Lbs)	Double Row (Lbs)
B/B	1200	2400	3000	4200	7200
	2000	2500	3100	4300	7400
	3000	2600	3200	4400	7600
B/A or A/B	1200	2300	2900	4100	7000
	2000	2400	3000	4200	7200
A/B	3000	2500	3100	4300	7400
A/A	1200	2000	2600	3800	6400
	2000	2100	2700	3900	6600
	3000	2220	2800	4000	6800

Breakers — Weights in Pounds

(Impact Weight = 1.5 X Breaker Weight)

Type of Breaker	Current Rating, Amps.		
	1200	2000	3000
Approx. Wt., Lbs.			
50VCP-W250	350	410	525
50VCP-W350	460	490	525
75VCP-W500	375	410	525
150VCP-W500	350	410	525
150VCP-W750	350	410	525
150VCP-W1000	460	490	525



Type VacClad-W Medium Voltage Metal-Clad Switchgear

Standard Designs — Vertical Sections (96.25 In. Deep) General Arrangement

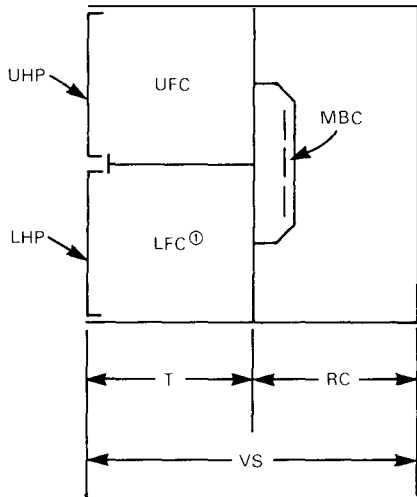

General Arrangement

- UHP Upper Hinged Panel
- LHP Lower Hinged Panel
- MBC Main Bus Compartment — 1200, 2000, 3000A as required
- UFC Upper Front Compartment
- LFC Lower Front Compartment
- RC Rear Compartment
- T Type of Vertical Section: Defined by combinations of UFC and LFC
- VS Complete Vertical Section: Defined by combinations of T and RC

Types of Vertical Sections

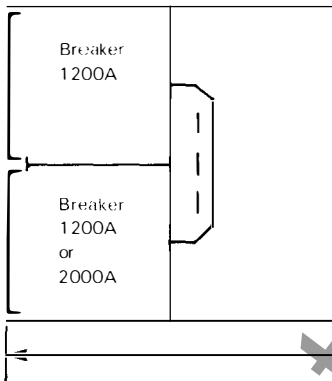

Type B/B

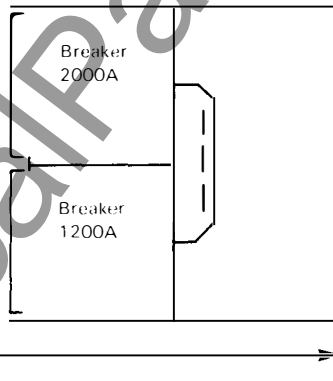

Type B/A

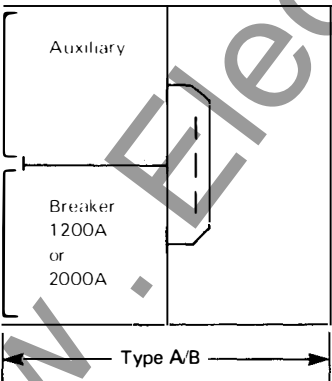

Type A/B

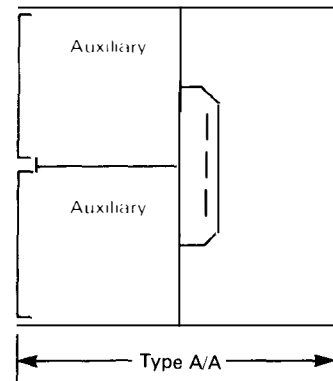

Type A/A

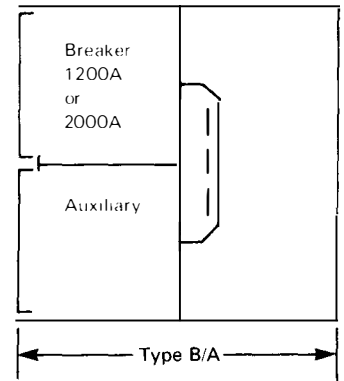

Type A/B

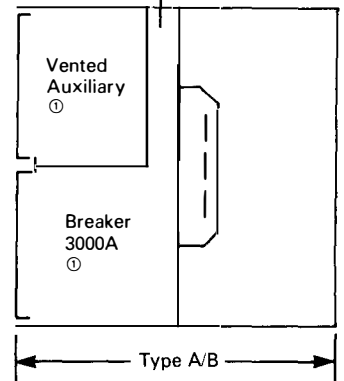

Ⓢ Caution: 3000 amp breaker located only in LFC and requires vented auxiliary in UFC.



Type VacClad-W Medium Voltage Metal-Clad Switchgear

Standard Designs — Vertical Sections (96.25 In. Deep), *Continued*
 Front Auxiliary Compartments

Upper Auxiliaries

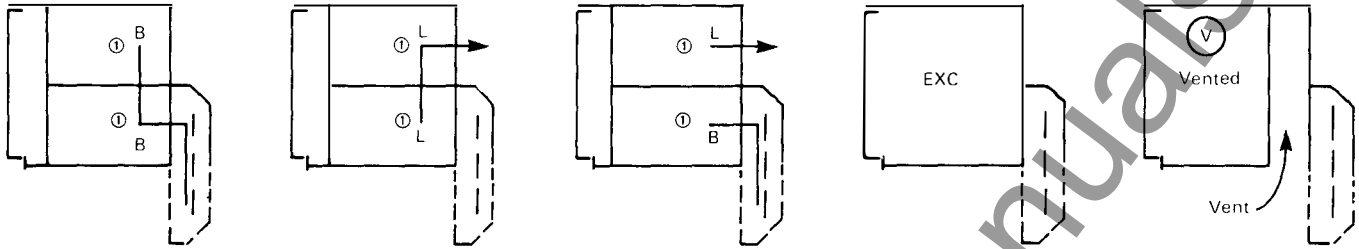

Lower Auxiliaries

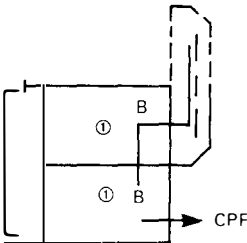
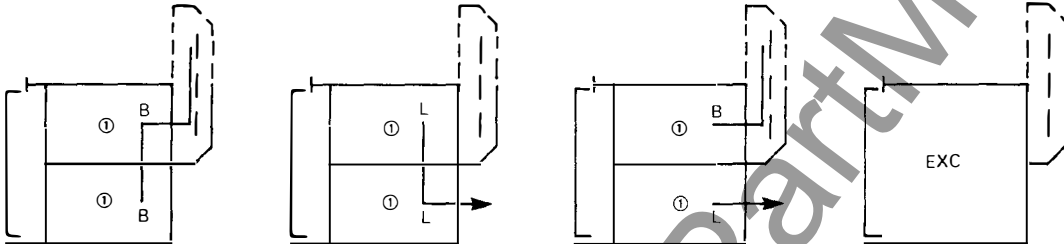

- ① CPD, Fuse or VT.
- CPD Drawout cont. pwr. trans: Fused primary, mechanically interlocked secondary breaker, single phase, line to line, 15 kVA Max.
- CPF Fixed cont. pwr. trans.
- Fuse Drawout fuses for CPF. Mechanically interlocked secondary breaker, three max, 25E max.
- PT Drawout pot. trans. Fused primary and secondary, three in WYE max, two in open delta max.
- B Bus connection
- L Line connection
- EXC Brushless exciter auxiliary secondary and control



Type VacClad-W Medium Voltage Metal-Clad Switchgear

Standard Section Views

Breaker-Over-Breaker (B/B) — Top Power Conductor Entrance

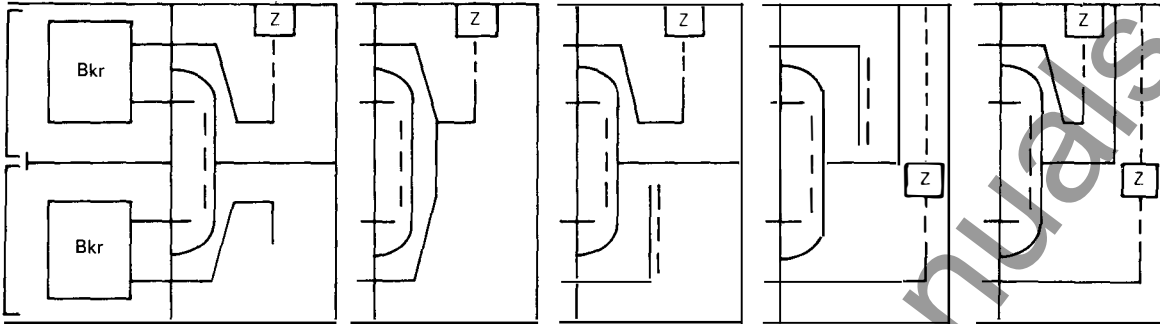

Figure 1

Figure 2

Figure 3

Figure 4

Figure 5

Breaker-Over-Breaker (B/B) — Bottom Power Conductor Entrance

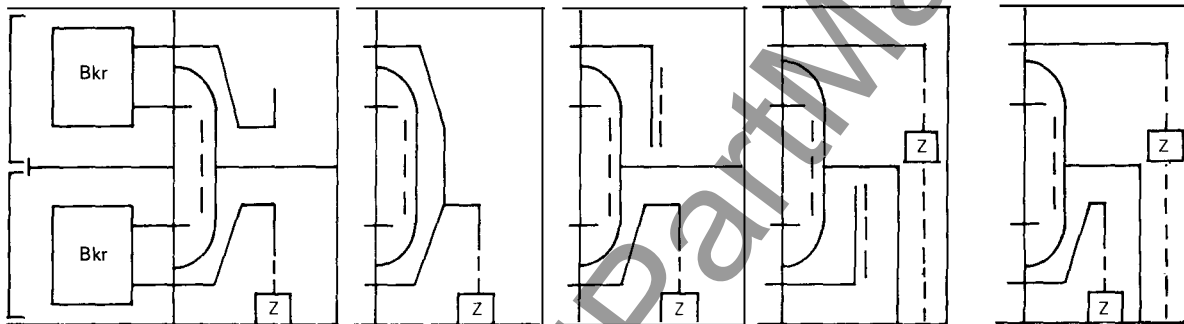

Figure 1

Figure 2

Figure 3

Figure 4

Figure 5

Breaker-Over-Auxiliary (B/A) — Top Power Conductor Entrance

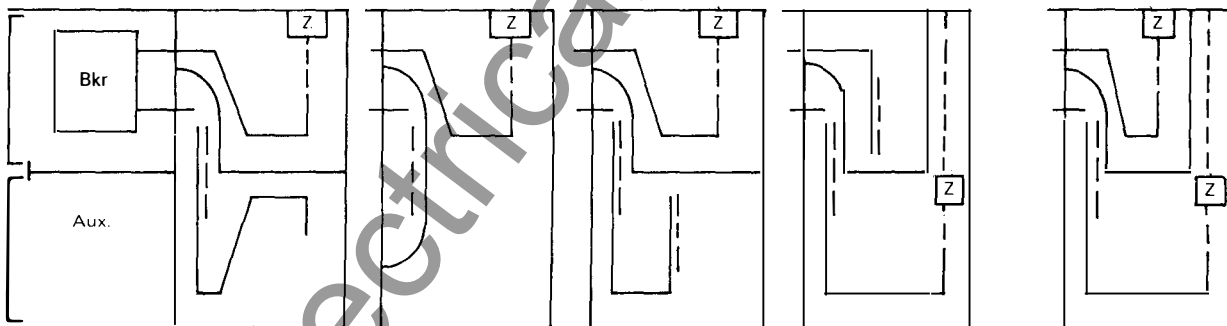

Figure 1

Figure 2

Figure 3

Figure 4

Figure 5

Breaker-Over-Auxiliary (B/A) — Bottom Power Conductor Entrance

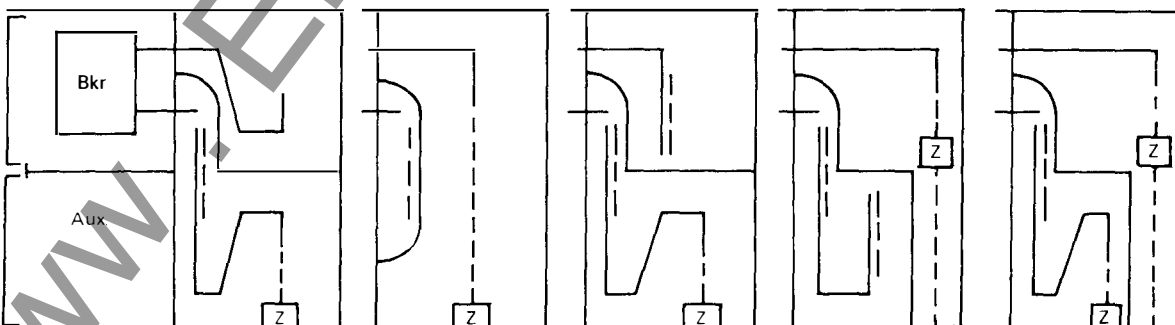

Figure 1

Figure 2

Figure 3

Figure 4

Figure 5

Z = Zero Sequence Current Transformer



Type VacClad-W Medium Voltage Metal-Clad Switchgear

Standard Section Views, *Continued*

Auxiliary-Over-Breaker (A/B) — Top Power Conductor Entrance

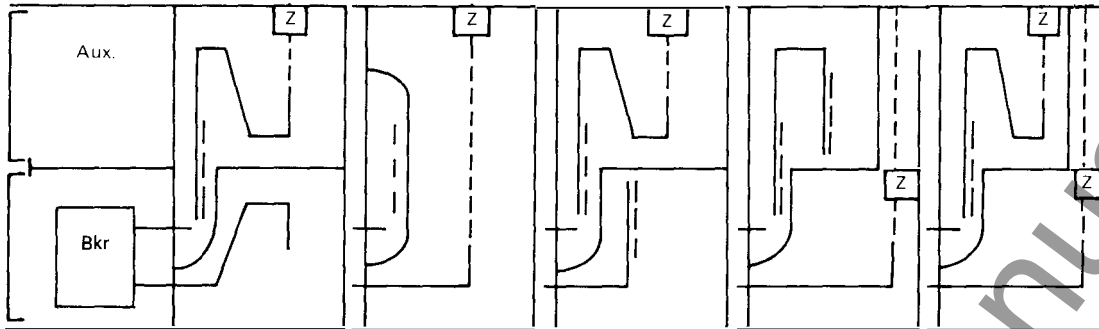

Figure 1 Figure 2 Figure 3 Figure 4⓪ Figure 5

Auxiliary-Over-Breaker (A/B) — Bottom Power Conductor Entrance

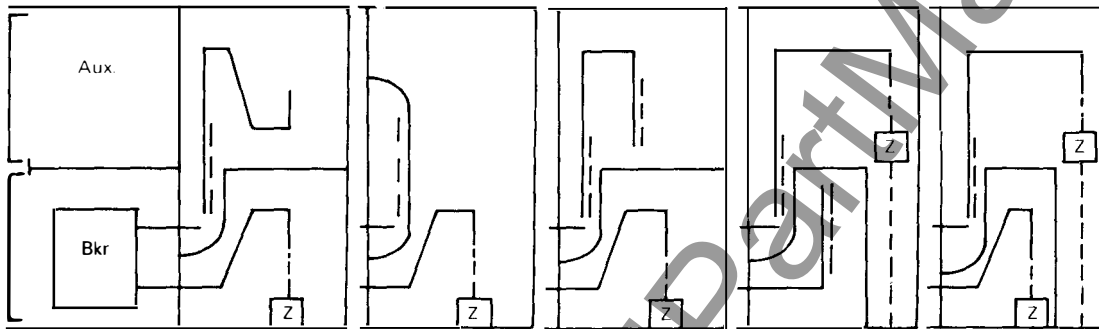

Figure 1 Figure 2 Figure 3⓪ Figure 4 Figure 5

Auxiliary-Over-Auxiliary (A/A) — Top Power Conductor Entrance

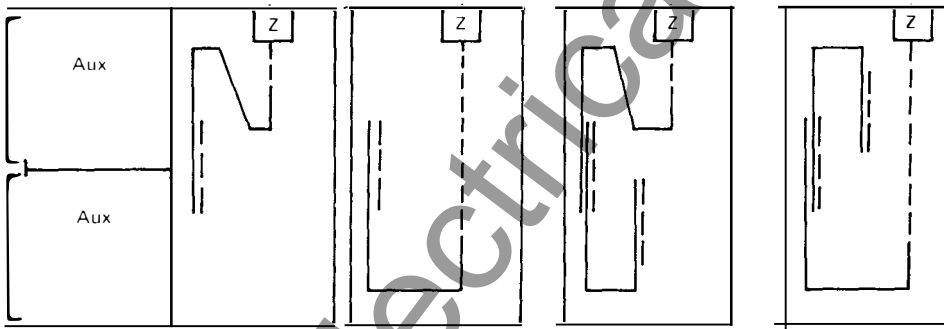

Figure 1 Figure 2 Figure 3 Figure 4

Auxiliary-Over-Auxiliary (A/A) — Bottom Power Conductor Entrance

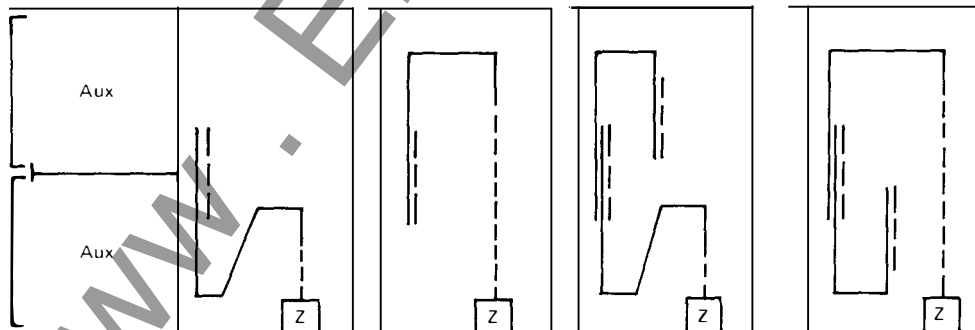

Figure 1 Figure 2 Figure 3 Figure 4

Z = Zero Sequence Current Transformer

⓪ Caution: 3000 amp bus sectionalizing is available, but with no power conductor entrances.



Type VacClad-W Medium Voltage Metal-Clad Switchgear

Standard Section Views, *Continued*

3000A Configurations

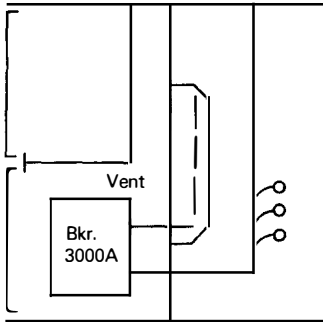

Figure 1

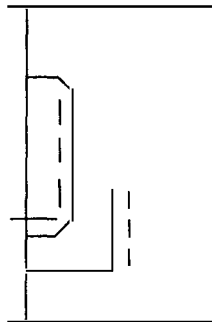

Figure 2

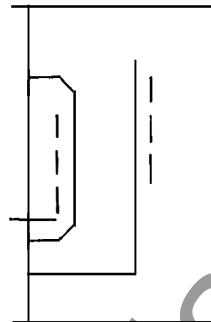

Figure 3

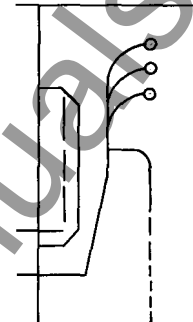

Figure 4

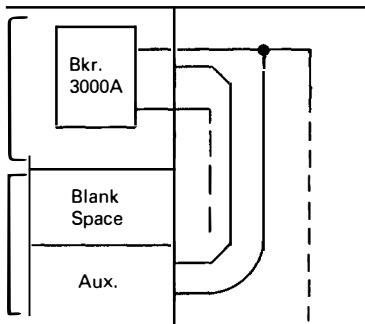

Figure 1

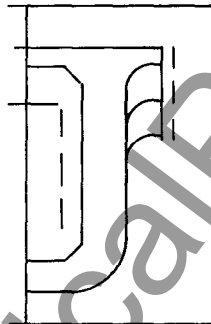

Figure 2

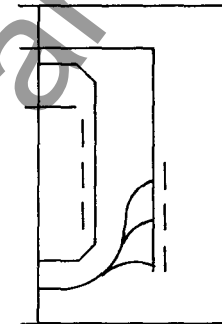

Figure 3

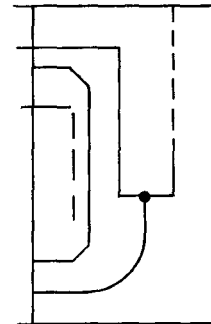
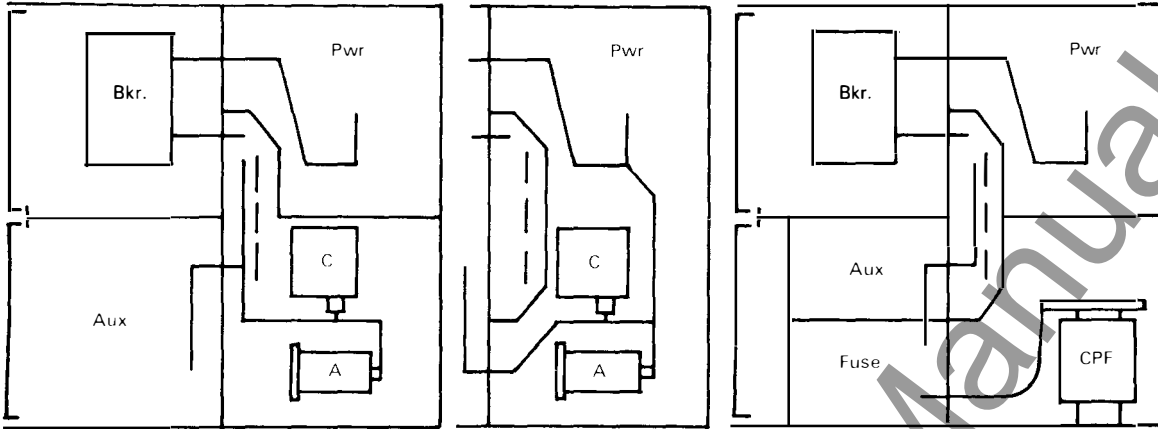

Figure 4



Type VacClad-W Medium Voltage Metal-Clad Switchgear

Standard Designs — Vertical Sections (96.25 In. Deep)
 Arresters, Capacitors, and Fixed Control Pwr. Trans.



Type B - A (Typical)

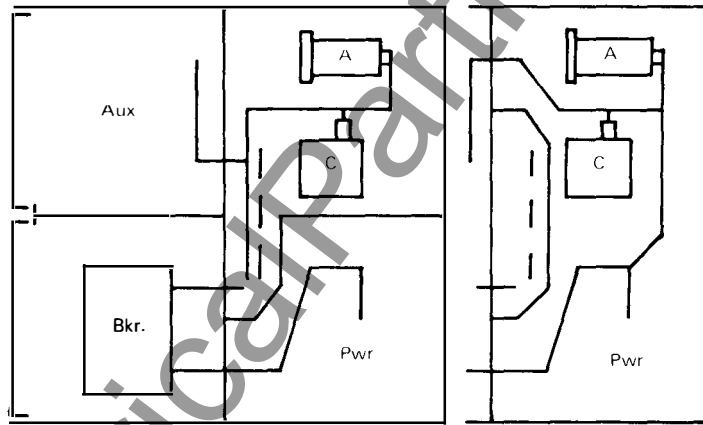

Type A/B (Typical)

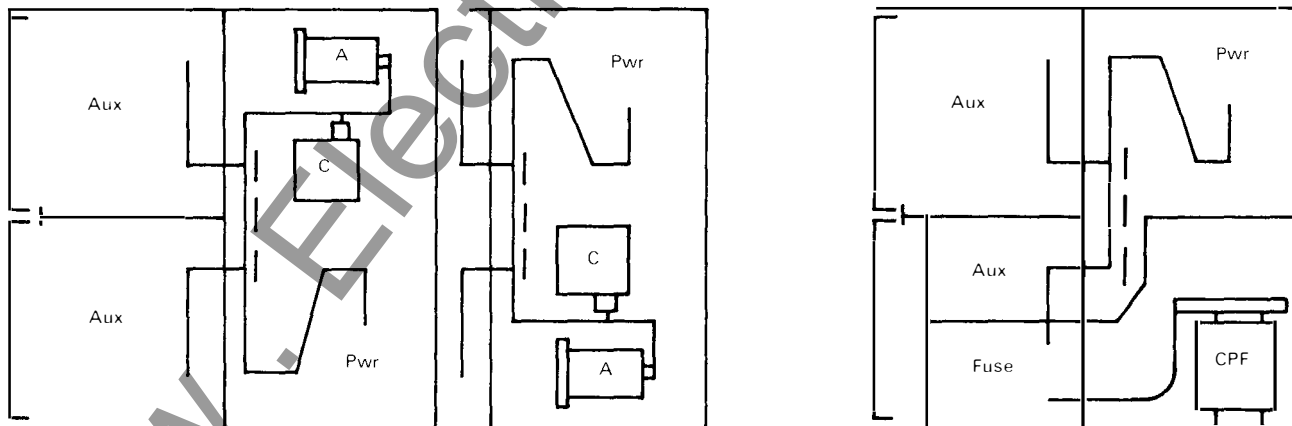

Type A/A (Typical)

- A Arrester, Station Type
- B Breaker: 1200A or 2000A
- C Capacitor, Surge
- CPF Control Pwr. Trans. Fixed One Phase,
50 kVA Max. or Three Phase, kVA Max
- Pwr Power Conductor Arrangement
- Aux Auxiliaries



Type VacClad-W Medium Voltage Metal-Clad Switchgear

Standard Designs — Vertical Sections (96.25 In. Deep), *Continued* Primary Cable Entrance (Top Elevation or Base Plan)

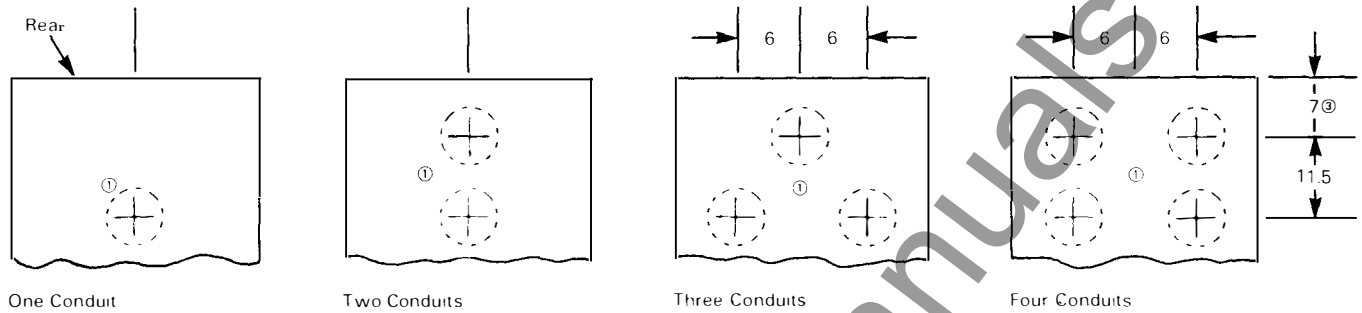

Fig. A — For Entrances Into Compartment Without Cable Enclosure

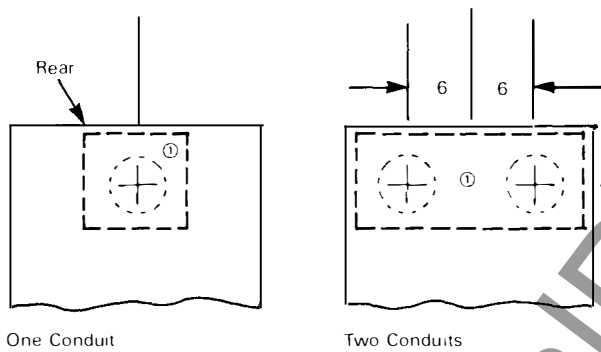

Fig. B — For Entrances Into Cable Enclosure (Or Cable Enclosure Area)

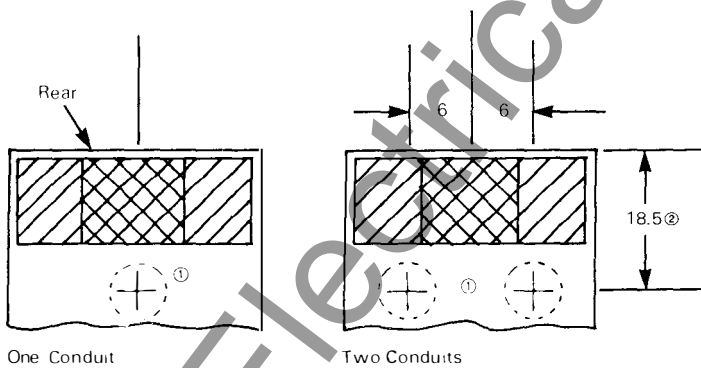

Fig. C — For Entrances Into Compartment With Cable Enclosure

- ① Primary cable and conduit entrance must be within 6.5 in. diameter entry area.
- ② Changes to 19.75 for optional hinged rear doors (structure depth becomes 97.5 inches).
- ③ Changes to 8.25 for optional hinged rear doors (structure depth becomes 97.5 inches).



Type VacClad-W Medium Voltage Metal-Clad Switchgear

How to Arrange, Select, and Specify VacClad-W

Arrange a primary one line as typically shown below. Note that the chart identifies the specific vertical sections (or rear compartments) selected based primarily upon the direction of power conductor entrance.

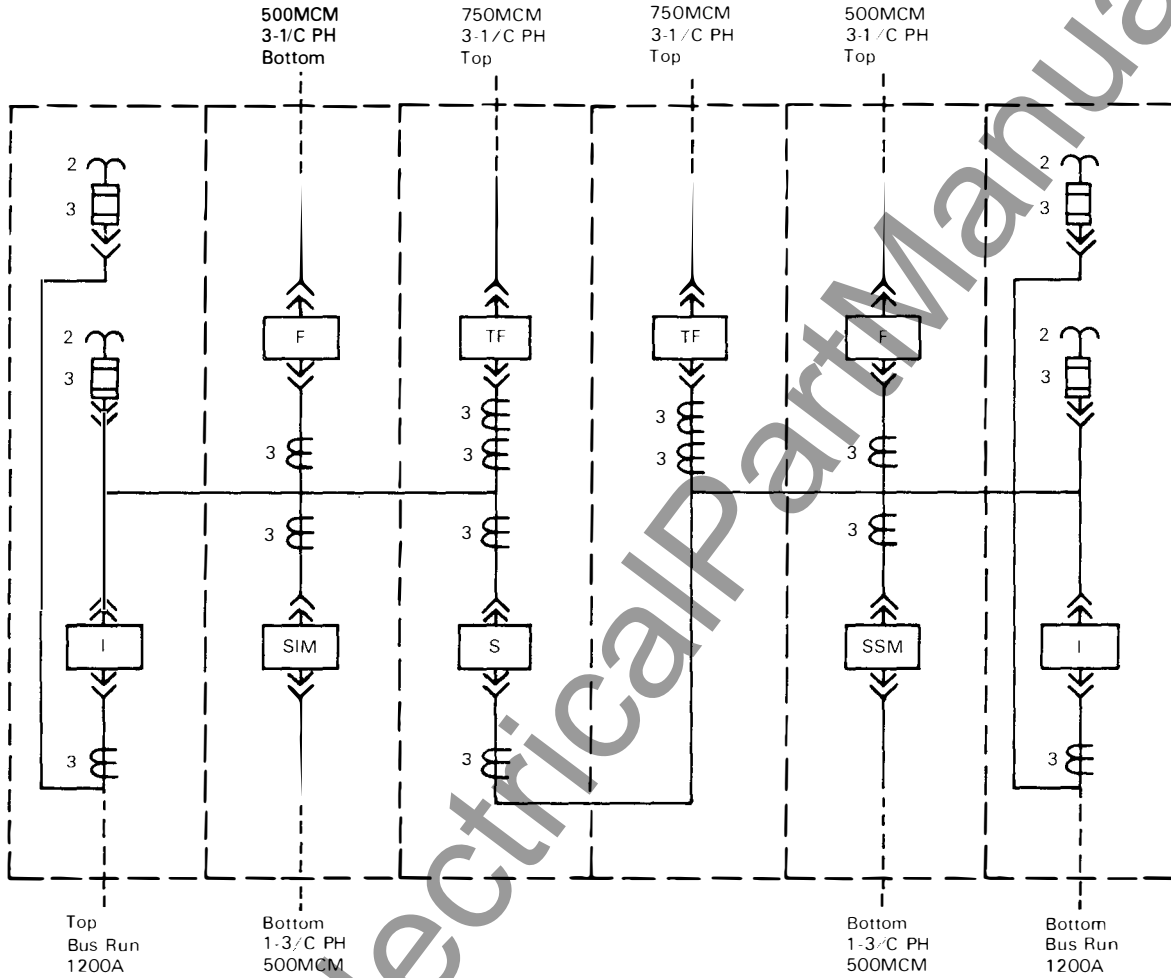

www.ElectricalPartManuals.com



Type VacClad-W Medium Voltage Metal-Clad Switchgear

How to Arrange, Select and Specify VacClad-W, *Continued*

Select your list of components. (The primary one line instrument transformer details can now be completed.) Typical arrangement for the primary one line is shown on the front view below.

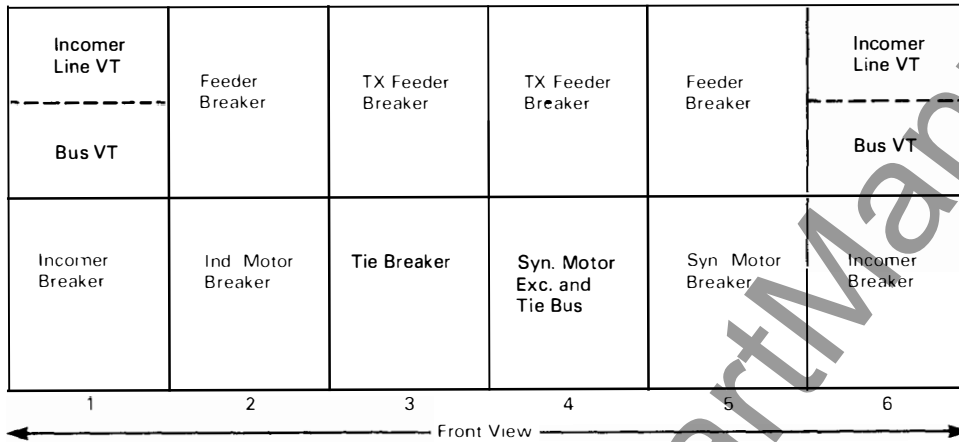

General Information Required

Specify the following general information:

- a. Indoor, aisle-less, or sheltered-aisle (single or double row)
- b. Shipping group limitations
- c. System voltage, frequency, phase sequence, and grounding
- d. System MVA or short circuit requirements
- e. Main bus continuous current rating
- f. Control voltage
- g. Control cable entrance (Top or bottom and vertical section)

Compartment Information Required

Specify the following information for each compartment:

- a. Circuit nameplate wording
- b. Breaker continuous current rating
- c. Identification of remote equipment controlled by VacClad-W
- d. Relay characteristics
- e. If not on primary one line:
 - Instrument transformer ratios
 - Complete power conductor information—top or bottom, size, number, type of termination



Type VacClad-W Medium Voltage Metal-Clad Switchgear

Typical Specifications

Item No. _____

_____ kV Metal-Clad Switchgear

_____ Complete assembly of _____ kV, [Indoor] [Outdoor Aisle-less] [Outdoor Sheltered Aisle] Metal-Clad Switchgear for the _____

VacClad-W Switchgear will consist of a stationary structure assembly and one or more removable type vacuum circuit breakers. The switchgear assembly will be constructed from individual vertical sections. They will be bolted together to form a rigid metal-clad switchgear assembly. Metal side sheets will provide grounded barriers between adjacent structures. Solid removable metal barriers will isolate the primary major sections of each circuit. Rear sheets will be steel with two pieces per vertical section to provide circuit isolation and ease of handling. Final finish is a coat of light gray paint, ANSI #61.

The main bus will be copper and will have fluidized bed epoxy flame-retardant and track-resistant insulation. Bus supports between units will be flame-retardant, track-resistant, glass polyester. All bus joints will be plated, bolted and insulated with easily installed boots. The bus will be braced to withstand fault currents equal to the close and latch rating of the breakers. The temperature rise of the bus and connections will be in accordance with ANSI standards and documented by design tests. A ground bus will extend the entire length of the switchgear.

Each circuit breaker compartment will be equipped to house a removable breaker element. The mechanism for levering the breaker will be cell mounted. It will include all of the necessary interlocks to render the breaker mechanism mechanically trip free during the levering procedure. The stationary primary contacts will be silver-plated and recessed within insulating tubes. A steel shutter will automatically cover the stationary primary disconnecting contacts when the breaker is in the disconnected position or out of the cell. Rails will allow withdrawal of each circuit breaker for inspection and maintenance without the use of a separate lifting device.

Each type vacuum breaker will be horizontal drawout type, capable of being withdrawn on rails. The breaker will be operated by a motor charged spring type stored energy mechanism, charged normally by a universal electric motor. In an emergency, charging will be by a manual handle. The primary disconnecting contacts will be silver-plated copper. Each circuit breaker will contain vacuum interrupter assemblies which can be removed as complete units. The vacuum interrupter pole unit will be mounted on glass polyester supports. A contact wear gap indicator, which requires no tools to determine available contact life, will be provided. The current transfer from the vacuum interrupter moving stem to the breaker main conductor will be a non-sliding design. The breaker front panel will be removable when the breaker is withdrawn for inspection or maintenance.

[Outdoor Aisle-less Enclosure]

The metal-clad switchgear includes aisle-less outdoor construction.

The basic switchgear units are surrounded by a complete weatherproof enclosure of heavy gauge steel. A weatherproof door is provided on the breaker drawout side of each housing. Lights, space heaters, and receptacles are provided inside each unit.

An undercoating compound is applied to the underside of all bottom surfaces.

[Outdoor Sheltered-Aisle Enclosure]

The metal-clad switchgear includes Outdoor Sheltered-Aisle Enclosure walk-in construction.

The basic switchgear units are installed in a heavy-gauge steel enclosure which provides a sheltered aisle space in front of the switchgear and complete weather protection for the equipment. Doors, provided with "crash" latch mechanisms are located at both ends of the lineup. The aisle has sufficient area to permit interchanging breakers between cells. Aisle lights, switches, ground fault service receptacles and space heaters are provided in each line-up.

An undercoating compound is applied to the underside of all switchgear units. The Sheltered-Aisle is shipped assembled, minimizing field erection time and expense.

A basic compartment containing a circuit breaker element is provided with the following equipment:

- 1 - Metal-clad stationary cell
- 1 - Vacuum circuit breaker removable element
- 1 - Set of three 2-hole NEMA drillings for each set of primary conductors
- 1 - Control power cutout
- 1 - Type W-2 breaker control switch with red and green indicating lights



Type VacClad-W Medium Voltage Metal-Clad Switchgear

[Other Equipment:]

[_____]
[_____]
[_____]
[_____]
[_____]
[_____]
[_____]
[_____]
[_____]
[_____]
[_____]

Unit No. _____ (_____)

- _____ - Auxiliary unit(s) [each] with the following total devices:
- _____ - Set(s) of main bus, rated _____ A
- _____ - Set(s) bar risers to bus run _____ A
- _____ - Bus transition(s)
- _____ - Bus entrance(s)
- _____ - _____
- _____ - Potential transformers drawer mounted, with current-limiting primary fuses, ratio _____ kV; 120 V, connected _____
- _____ - _____ kVA _____ phase dry-type control power transformer(s) with current-limiting primary fuses, secondary breaker, interlocks, compartment provisions and connections
- _____ - Indicating AC Ammeter(s)
- _____ - Ammeter transfer switch(es)
- _____ - Indicating AC Voltmeter(s)
- _____ - Voltmeter transfer switch(es)
- _____ - Indicating Wattmeter(s)
- _____ - _____
- _____ - _____