



PLC 1790/B

Power Line Carrier

Revision2

Technical Manual

1790B/EN T/F11

www.ElectricalPartManuals.com

PLC 1790/B POWER LINE CARRIER

CONTENT

Presentation	1790B/EN IT/E11
Installation	1790B/EN IN/F11
Functional Description	1790B/EN FT/E11
Commissioning	1790B/EN CM/F11
Human Machine Interface	1790B/EN HI/F11

PAGE BLANCHE

www.ElectricalPartManuals.com

PRESENTATION

www.ElectricalPartManuals.com

www.ElectricalPartManuals.com

CONTENTS

1.	PRESENTATION	5
1.1	Definition	5
1.2	Evolution	6
1.3	Communication channels	6
1.4	Main features	6
1.5	Loop mode for maintenance purposes	7
1.6	Signal equalization	8
1.6.1	HF channel equalization	8
1.7	PLC terminal programming by MMI	8
1.8	Transit interface (INTE CARD)	9
1.9	Teleprotection interface	9
1.10	PLC remote monitoring	9

2.	COMPOSITION OF THE EQUIPMENT	10
-----------	-------------------------------------	-----------

3.	MAIN CHARACTERISTICS	12
3.1	Low Frequency Section	12
3.2	High Frequency section	15
3.3	General technical and electrical data	16
3.3.1	Power supply	16
3.3.2	Dielectric rigidity and insulation resistance (iec 255-5)	16
3.3.3	Interference immunity	17
3.4	Appendix	18

BLANK PAGE

www.ElectricalPartManuals.com

MODIFICATIONS PAGE

Version	DATE	COMMENTS
A	June 1998	ORIGINAL ISSUE
B	December 1998	Modification of page 11, 12, 13, 15, 16, 17
C	Sept. 1999	New presentation + modification of page 9, 12,13, 16,18
D	March. 2004	New presentation + Description of the PLC1790B Revision 2
E	September 2004	Minor change, editing for 2 side printing

BLANK PAGE

www.ElectricalPartManuals.com

1. PRESENTATION

1.1 Definition

This paragraph defines terms and abbreviations used in this technical manual.

LIST OF ACRONYMS AND ABBREVIATIONS

ACRONYM	MEANING
PLC 1790/B	Analogue Power Line Carrier
ALIM	Power Supply Unit
AMPL	20 W Amplifier
BN or NB	Nominal Band
AGC	Automatic Gain Control
ITU-T	International Telecommunication Union - Telephony
CCUN	Universal Call Converter Unit
DSP	Digital Signal Processing
DTE	Data Terminal Equipment
EEPROM	Electrically Erasable Programmable Memory
MODAF	High Frequency Modem
ELNU	Digital Processing Unit
FS	Sampling Frequency
FSK	Frequency Shift Keying
HF	High frequency
HV	High Voltage
IEC	International Electro technical Commission
INSU	Supervisory Interface
LF	Low Frequency
MC	Common Mode
MD	Differential Mode
PC	Personal Computer
PCB	Printed Circuit Board
PLC	Power Line Carrier
QPSK	Quadrature Phase Shift Keying
ROM	Read Only Memory
RX	Reception
SSB	Single Side Band
TS	Sampling Time
TX	Transmission
LFS	Low Frequency Section

1.2 Evolution

PLC 1790/B Revision2 represents the technological evolution of the PLC 1790/B.

The product is functionally equivalent and line-compatible with previous versions and introduces some minor additional facilities (like automatic selection of best switching frequency of the power supply, reverse Tx/Rx band programming, flexible programming of equipment alarms) and better EMC characteristics.

1.3 Communication channels

AREVA new generation Power Line Carrier terminal PLC 1790/B Revision2, is a transceiver unit operating on single or dual channel configurations - Single Side Band and attenuated carrier - and supporting analogue transmission services over High Voltage electrical lines.

PLC 1790/B Revision2 terminal operates within 40 and 500 kHz frequency range with a channel stepping of 4 Hz.

The available net bandwidth at 4 kHz channel steps is 300 ÷ 3720 Hz.

1.4 Main features

Thanks to the implementation of very large scale integration components such as FPGA Gate Arrays and to the wide implementation of "DSP" (digital signal processing) techniques, the new generation PLC 1790/B Revision2 terminal features easy to use - programmable functions along with effective built-in maintenance facilities in a very compact packaging.

The main features include:

Transmission/reception of speech, call and telegraph signals.

Transmission/reception of asynchronous serial data at 50-100-200-600-1200 Bit/s using the superimposed frequency band (also called speech plus).

Transmission/reception of synchronous serial data at 2400-4800-9600 Bit/s using the whole 4 kHz bandwidth and an external modem.

Data to be transmitted can be input via an external modem or via an RS 232 interface. The PLC 1790/B Revision2 also provides for the appropriate modulation/demodulation functions when the RS 232 option is adopted.

PLC 1790/B Revision2 has been conceived using the signal digital processing (DSP) techniques carried out by mathematical microprocessors and "gate-array" which allowed to achieve an improvement of performances and a considerable flexibility at lower costs.

1.5 Loop mode for maintenance purposes

The PLC 1790/B Revision2 has been developed taking into account the requirements received from the market in order to facilitate the maintenance activities.

In the maintenance mode the operator can use his console to put the system in local loop or remote loop condition.

LOCAL LOOP

It is strongly recommended to connect the PLC HF output on Dummy Load to perform the Local Loop Test.

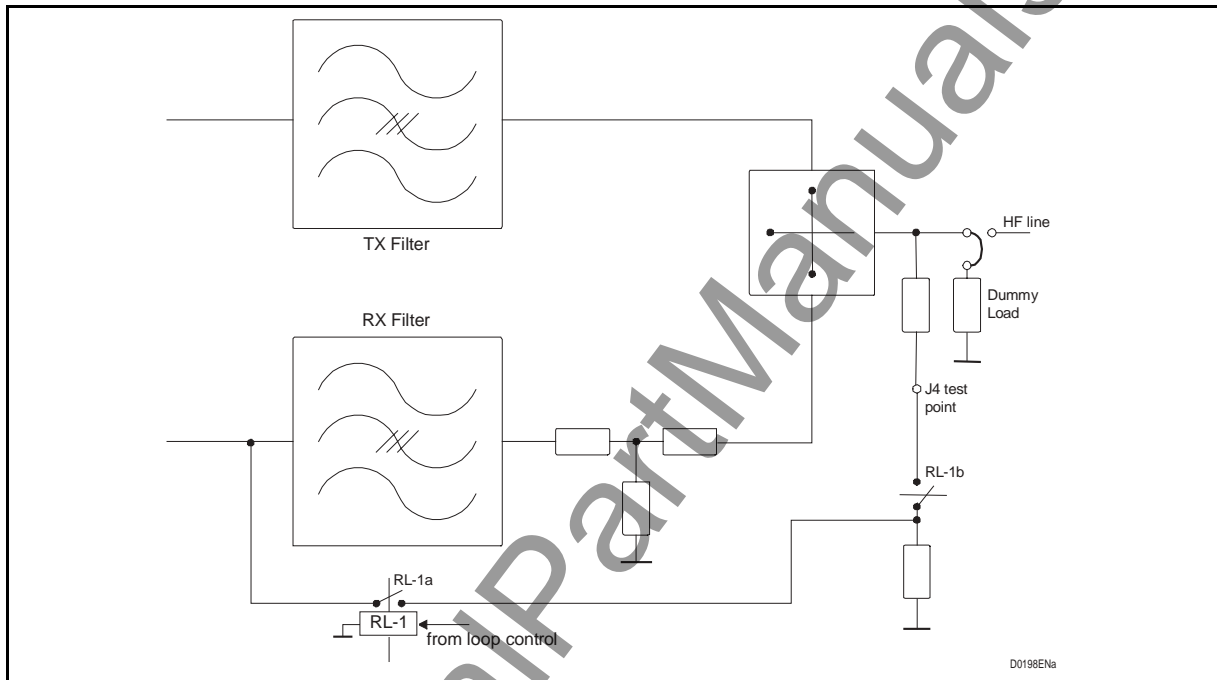

FIGURE 1 – LOCAL LOOP BLOCK DIAGRAM

In the local loop condition the transmitter and receiver sections are automatically programmed with the same band.

Once the terminal is in local loop, the connection with the remote PLC equipment is open in order to avoid possible commands in the remote Teleprotection equipment (if any).

The local loop is detected by the lighting on of yellow LED on MODAF card, and the good result by lighting off of the receive line alarms, i.e. -5dB , S/N.

On the LFS cards also, the signaling Rx alarm should disappear.

The local loop duration is limited to 10 minutes.

REMOTE LOOP TEST

The purpose of this test is to verify that both PLC are on line and receiving the relative carriers.

The indications available on the local PLC do not give any information about the status of the remote one.

By mean this test, the local PLC, performing an analogue Amplitude Modulation of the TX carrier send a message to the remote equipment.

On the receive side the message is decoded and send-back to the originating equipment, where the acknowledgment of the message is the confirmation that the HF side of the link is up.

This function checks the round trip connection of a PLC link using a single operator.

1.6 Signal equalization

1.6.1 HF channel equalization

The PLC equipment can equalize the received band from the HF side, using 8 reference tones, transmitted over 300 - 3720 Hz bandwidth.

When the PLC is equipped with the optional supervision board, called INSU, the equalization procedure can be managed from one side by one operator equipped with PC and MMI for maintenance purpose.

The procedure requires the availability on both sides of two operators equipped with PC and MMI for maintenance purpose.

The equalization procedure can be performed on both equipments simultaneously.

Whenever the PLC is under equalization the LF channels are not available.

Automatic equalization for HF signals

From one side, using the MMI the operator enables the transmission of the 8 tones.

On the receiving side the level of each single tones is compared with the reference one stored in the PLC under test which automatically calculates the equalization complementary to the received channel and apply the correction at LFS level, for each frequency. In this way the PLC link can be equalized easily in the whole band without any external tool.

Manual equalization for HF signals

The same procedure above described but the operator can select for each single tone the correction and send this data to the LFS to apply the correction.

Programmed equalization for HF signals

The operator can equalize the frequency band received from the Line 2, through a cable connecting a remote LF equipment, choosing one of the fifteen curves stored in the LFS card firmware.

1.7 PLC terminal programming by MMI

The PLC equipment is programmed by MMI installed on standard PC equipped with one serial port and running under Windows® 95 or higher.

MODAF, LFS and INSU cards use a DSP technology in order to implement functions by residential programs and they are connected through the equipment bus to an external terminal to program all audio frequency services, levels and high frequency band of the PLC equipment.

Using the INSU card it is possible to program the remote PLC terminal. A telegraph data channel at 50 baud, located in one available data channel band, is used to send messages to the remote INSU card in order to program in the remote LFS card the signal levels, audio frequency band, modem data rate and frequency.

It is possible to program the PLC equipment with one or two communication channels using one or two LFS cards.

It is also possible to program one communication channel using two LFS cards in order to increase the services to be transmitted towards the remote PLC (speech, data, teleprotection signal, telegraph channels, fax,..).

1.8 Transit interface (INTE CARD)

A transit function is available in order to retransmit the received whole band towards remote equipment.

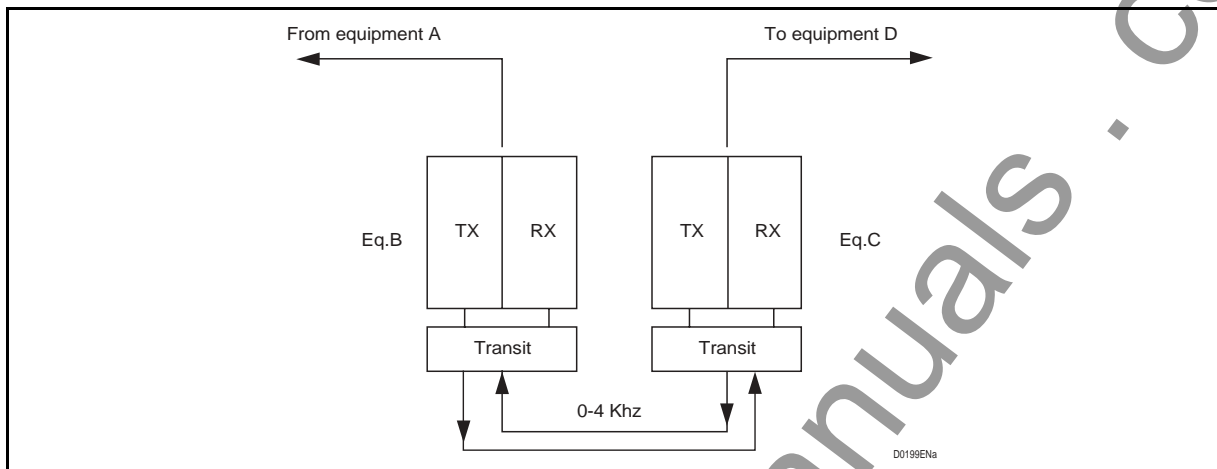

FIGURE 2 – INTE FUNCTIONAL BLOCK

1.9 Teleprotection interface

PLC equipment can connect a local Teleprotection terminal by the LINE 2 interface and transmit the commands towards the remote Teleprotection equipment.

LINE 2 interface allows tuning the analogue signal levels according to Teleprotection requirements.

1.10 PLC remote monitoring

Using the optional INSU card, PLC 1790/B Revision2 equipment can program and monitor the remote terminal by a 50-baud telegraph channel.

The INSU card can send and receive to the remote PLC equipment from 1 to 4 signals in order to transmit or monitor the status of general-purpose criteria.

Open collector alarms are available in the INSU card to be connected to a remote terminal unit, which belongs to a supervisory communication network system.

2. COMPOSITION OF THE EQUIPMENT

The equipment includes a 9 units subrack housing the power supply and power amplifier sections along with the electronic units applicable on the basis of the selected operating configuration.

Reference can be made to figure 3, which shows the subrack layout of the PLC 1790/B Revision2.

In the following, table 1 lists the various units, and their maximum quantity, that can be equipped in a PLC 1790/B Revision2 terminal.

Position	Code	Description	Acronym	Max. Qty	Note
2	478.410.000 Y	Power Supply Unit	ALIM	1	
14 - 26	411.410.034 J	Low Frequency Section	LFS	2	(1)
14 - 26	411.410.035 L	Low Frequency Section	LFS-3	2	(1)
14 - 26	474.412.011 Q	Transit Interface	INTE	1	(1)
20	474.415.026 J	Universal Call Converter	CCUN	1	(2)
32	411.410.027 K	Supervision. Interface	INSU	1	(2)
36	299.704.331	Cover Plate			
40	411.410.039	High Frequency Modem	MODAF	1	
45 - 55	474.412.008 E	20W Amplifier	AMPL	2	
65	474.412.009 F	TX Line Interface	INTX	1	
76	474.412.010 T	RX Line Interface	INRX	1	

TABLE 1 – EQUIPMENT UNITS

NOTE: (1) cards in alternative;
(2) cards optional

All units feature 32 or 64 pins Eurocard connectors, which plug into the subrack motherboard, which provides for the necessary interconnections.

Chapter 1790B/EN IN Installation, "Available Versions and Configurations" can be referenced for additional details.

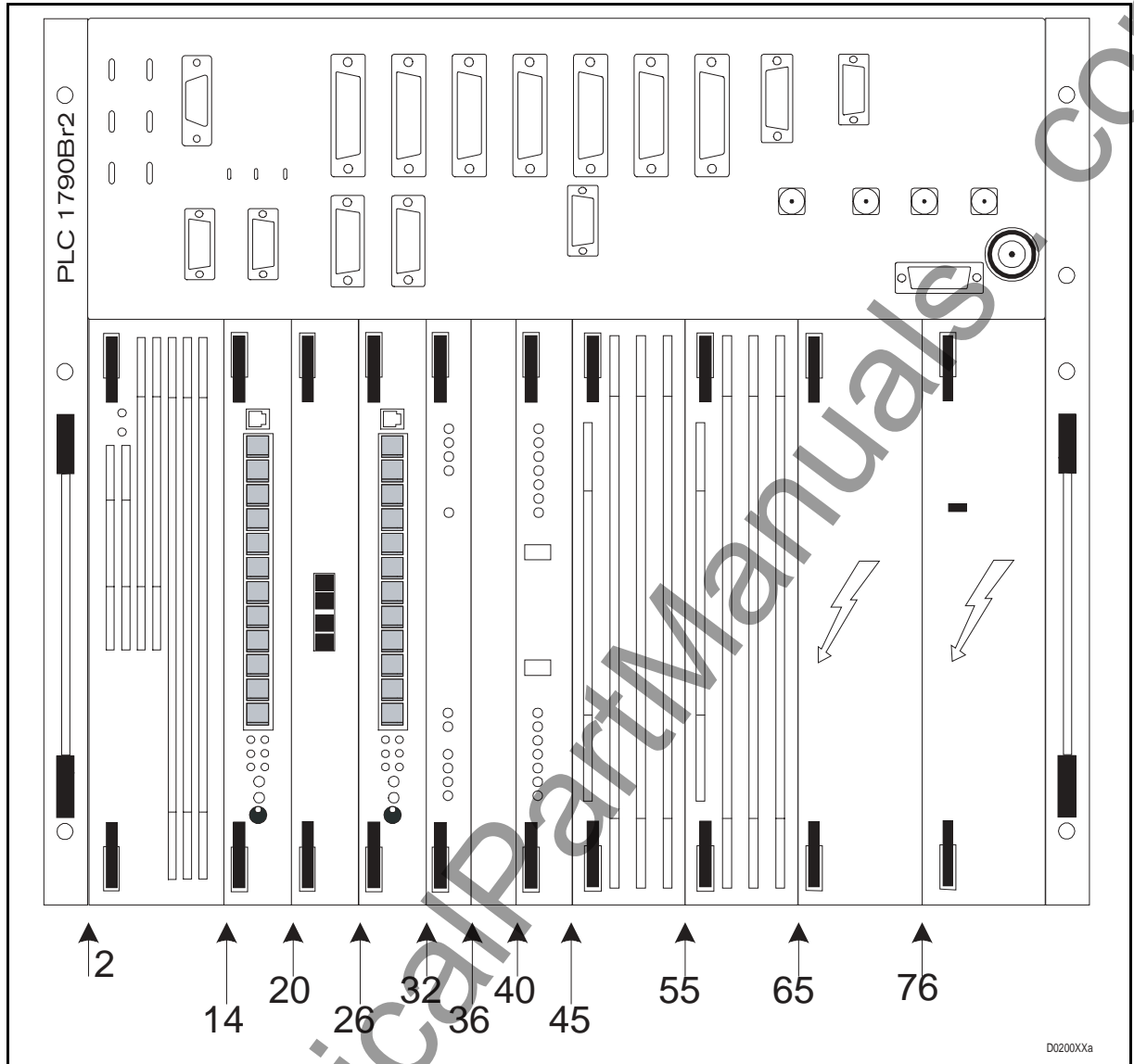

FIGURE 3 – PLC 1790/B REVISION2 LAYOUT

3. MAIN CHARACTERISTICS

3.1 Low Frequency Section

LF CARD LFS / LFS3

Signaling	
Programmable ON/OFF or FSK	
Fc Central Frequency	
Programmable bandwidth (Hz)	1750 ÷ 1870 ; 2160 ÷ 2280 ; 2260 ÷ 2380 ; 2280 ÷ 2400 ; 2460 ÷ 2580 ; 3600 ÷ 3720
Frequency shift	$F_c \pm 30$ Hz
Distortion	< 5%
Ring back tone	425 Hz (excludable)
Speech	
Programmable bandwidth (Hz)	300 ÷ 1700; 300 ÷ 2000; 300 ÷ 2200; 300 ÷ 2400; 300 ÷ 3400
Input/output impedance	Balanced 600 ohm
Symmetry	≥ 40 dB
Return loss attenuation	≥ 14 dB
4-wire Tx nominal level	-3.5 dBm
4-wire Tx level range	+1.5 ÷ -22.5 dBm by step of 0.5 dB
4-wire Rx nominal level	-3.5 dBm
4-wire Rx range	+7.5 ÷ -30.5 dBm by step of 0.5 dB
2-wire Tx nominal level	0 dBm
2-wire Tx level range	+5 ÷ -19 dB by step of 0.5 dB
2-wire Rx nominal level	-7 dBm
2-wire Rx level range	+4 ÷ -34 dB by step of 0.5 dB
Compandor	Dynamic compressor/expander according to ITU-T G.162 specifications
Limiter	According to IEC 60495 specifications

Telegraph service	
Programmable bandwidth (Hz)	1800 ÷ 2280; 1820 ÷ 3480; 1920 ÷ 2400; 2160 ÷ 3480; 2280 ÷ 3480; 2400 ÷ 3720; 2440 ÷ 3720; 2520 ÷ 3480; 2640 ÷ 3720; 300 ÷ 2400; 300 ÷ 3400; 300 ÷ 3720;
Input/output impedance	Balanced 600 ohm
Symmetry	>= 40 dB
Return loss attenuation	>= 14 dB
TX/RX nominal level	-14 dBm (for 50 Bd channel)
TX/RX level range	+5 ÷ -33 dBm by steps of 0.5 dB
LINE 2 interface	
Programmable bandwidth (Hz)	1800 ÷ 2280; 1920 ÷ 2400; 2160 ÷ 3480; 2280 ÷ 3480; 2400 ÷ 3720; 2440 ÷ 3720; 2640 ÷ 3720; 300 ÷ 2400; 300 ÷ 3400; 300 ÷ 3720; 300 ÷ 1870; 300 ÷ 2280; 300 ÷ 2380; 300 ÷ 2580;
Input/output impedance	Balanced 600 ohm
Symmetry	>= 40 dB
Return loss attenuation	>= 40 dB
TX nominal level	-28 dBm
TX level range	-11 ÷ -49 dBm by steps of 0.5 dB
RX nominal level	-28 dBm
RX level range	-10 ÷ -46 dBm by steps of 0.5 dB
MTU Multi Purpose Telegraph Unit	
In-build telegraph modem programmable:	
RATE	STANDARD
50 baud	ITU-T (R35) & PROPRIETARY
100 baud	ITU-T (R37) & PROPRIETARY
200 baud	ITU-T (R38A)
200 baud	ITU-T (R38B) & PROPRIETARY
600 baud	ITU-T (V23) & PROPRIETARY
1200 baud	ITU-T (V23)
1200 Bps	PROPRIETARY QPSK (on LFS-3 only)
Data interface	EIA (RS 232)

TRANSIT INTERFACE INTE

Useful bandwidth	300 ÷ 3720 Hz
Input/output impedance	balanced 600 ohm
Symmetry	>= 40 dB
Return loss attenuation	>= 40 dB
TX and RX nominal level	-28 dBm
TX level range	-39 ÷ -24 dBm
RX level range	-36 ÷ -21 dBm

NOTE: 1 Transit interface handle two channels

UNIVERSAL CALL CONVERTER CCUN

Frequency Converter	45 ± 5 Hz
Ringing voltage	50 Vrms on 3 k
Subscriber supply	30 V 25/30 mA

NOTE: 1 Universal call converter handle two Speech channels (LFS0 & LFS1)

ALARMS (RELAY)

Number of contacts	1 free changeover relay contact
Maximum current	1.25 A
Maximum voltage	125 VAC / 150 VDC
Cut-off power	30 W (VDC) / 50 VA (VAC)

ALARMS (OPEN COLLECTOR)

Maximum current	50 mA
Maximum voltage	-72 VDC

SUPERVISION INTERFACE INSU

Programmable bandwidth (Hz)	1 of the 28 channels 50 Bps R35 CCITT
Input commands	4 inputs (activated by dry loop)
Output commands	2 outputs (free voltage contact changeover) 2 outputs (ground reference)

3.2 High Frequency section

Transmission mode	Carried out by SSB, attenuated carrier, amplitude modulated, single or twin channel
HF Carrier	Single carrier for twin channel PLC programmable from 40 to 496 KHz
Transmission power	10; 20; 40 W (pep)
Line impedance Ω	50; 75; 125 unbalanced 125; 150 balanced
Return loss line	≥ 12 dB
Spurious emission	IEC 60495 Compliant
Selectivity	at 300 Hz from RX channel ≤ -65 dbm0 at 4 KHz from RX channel ≤ -75 dbm0
TX line filters	Programmable on a single board within 40 ÷ 500 KHz
RX line filters	Programmable on a single board within 40 ÷ 500 KHz
AGC dynamic	46 dB
Background noise	≤ -55 dBmOp
Near-end crosstalk noise	≤ -50 dBmOp
Far-end crosstalk noise	≤ -50 dBmOp
Harmonic distortion	≤ -40 dbm0 F= 400 Hz
Group delay (300 ÷ 3400 Hz)	IEC compliant
Total fidelity	IEC compliant
Frequencies stability	20 ppm from 0 to 45 °C

3.3 General technical and electrical data

3.3.1 Power supply

Battery primary supply	48 Vdc
Variation	-15% ÷ +20%
Psophometric residual	<3 mVpp
Ripple peak to peak	<10 mVpp
Galvanic isolation	Programmable
Protection against polarity inversion	Fuse
Power consumption	MAX. 150 Watt

PULSE TRANSIENT WITHSTAND (IEC 255-4)

HF Interface (Output)	3000 V imp. 1.2/50 (common mode)
HF Interface (Input)	3000 V imp. 1.2/50 (common mode)

ENVIRONMENTAL CONDITIONS

Operating temperature range	0 ÷ +45 °C
Maximum temperature	+55°C for a period ≤ 24 hours (IEC 495)
Storage / Transportation	-40 ÷ +70 °C
Relative humidity	≤ 93% at 40°C

3.3.2 Dielectric rigidity and insulation resistance (iec 255-5)

Rigidity (common mode)

Power supply	500 Vrms 50 Hz (one minute)
HF interface (input/output)	2000 Vrms 50 Hz (one minute)
Balanced LF interfaces	500 Vrms 50 Hz (one minute)
Signaling or alarm contacts	500 Vrms 50 Hz (one minute)
Insulation	> 10 MΩ 500 Vdc 35°C UR < 75%

3.3.3 Interference immunity

Electrical Fast Transient (IEC 61000-4-4)

Power supply	2000 V
HF interface (input/output)	2000 V
LF balanced interface	1000 V
Signaling or alarm contacts	1000 V

High frequency disturbance test (IEC 255-22-1)

Power supply	2500 V (CM) 1000 V (DM)
HF interface (input/output)	2500 V (CM) 1000 V (DM)
LF balanced interfaces	1000 V (CM) 500 V (DM)
Signaling or alarm contacts	1000 V (CM) 500 V (DM)

Radiated electromagnetic field (IEC 61000-4-3)

Radiated field value	10 V/m
----------------------	--------

ElectroSTATIC discharge (IEC 61000-4-2)

Discharge voltage value	8 KV
-------------------------	------

Transient withstand (IEC 255-4)

Power supply	5000 Vp imp. 1,2/50 (DM, CM)
HF interface (input/output)	5000 Vp imp. 1,2/50 (DM, CM)
LF balanced interface	1000 Vp imp. 1,2/50 (CM) 500 Vp imp. 1,2/50 (DM)
Signaling or alarm contacts	1000 Vp imp. 1,2/50 (CM) 500 Vp imp. 1,2/50 (DM)

3.4 Appendix

SPEECH - SIGNALING - TELEGRAPH

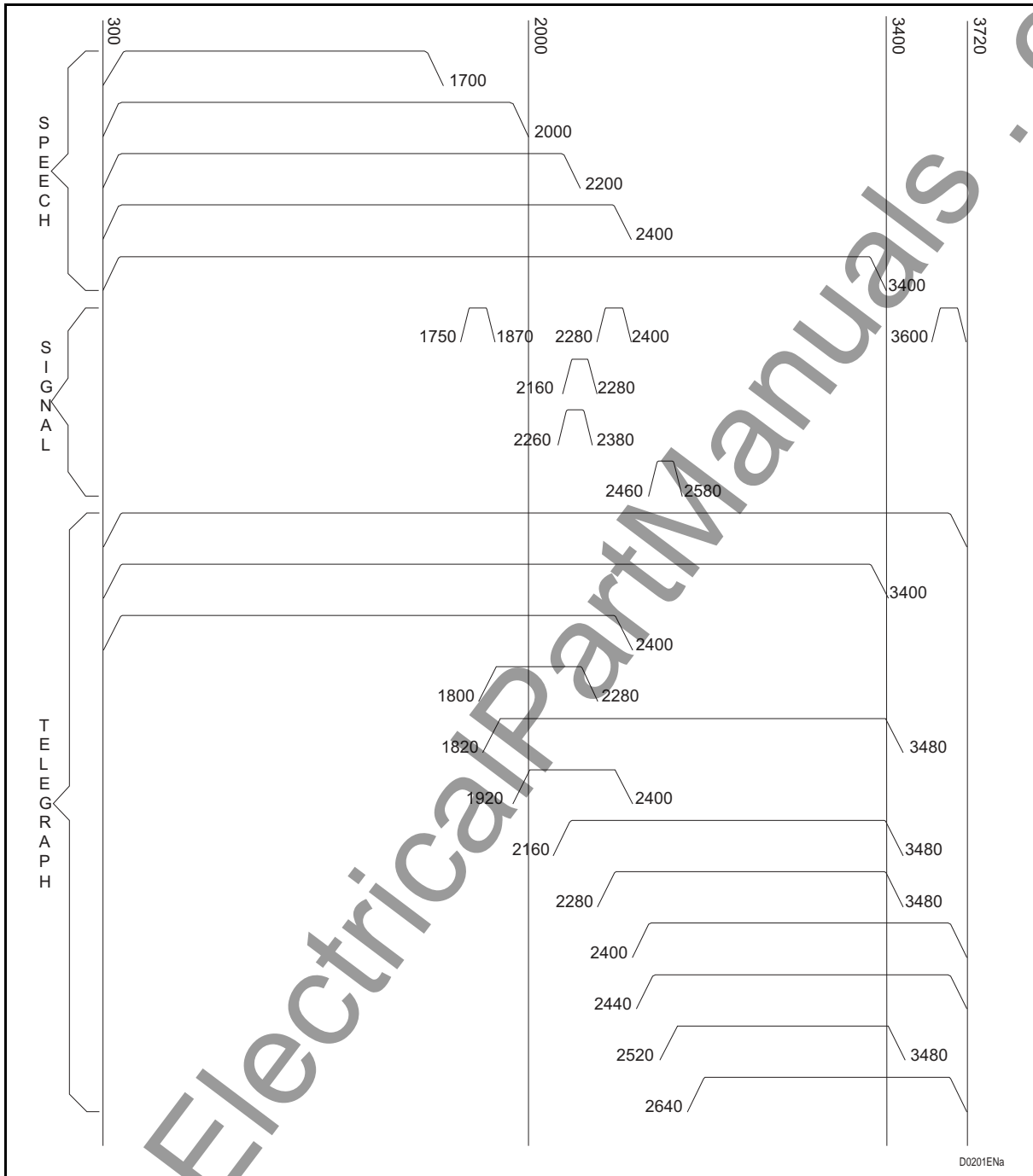

FIGURE 4 – LF SERVICE ALLOCATION

BUILT-IN MTU CHANNELS

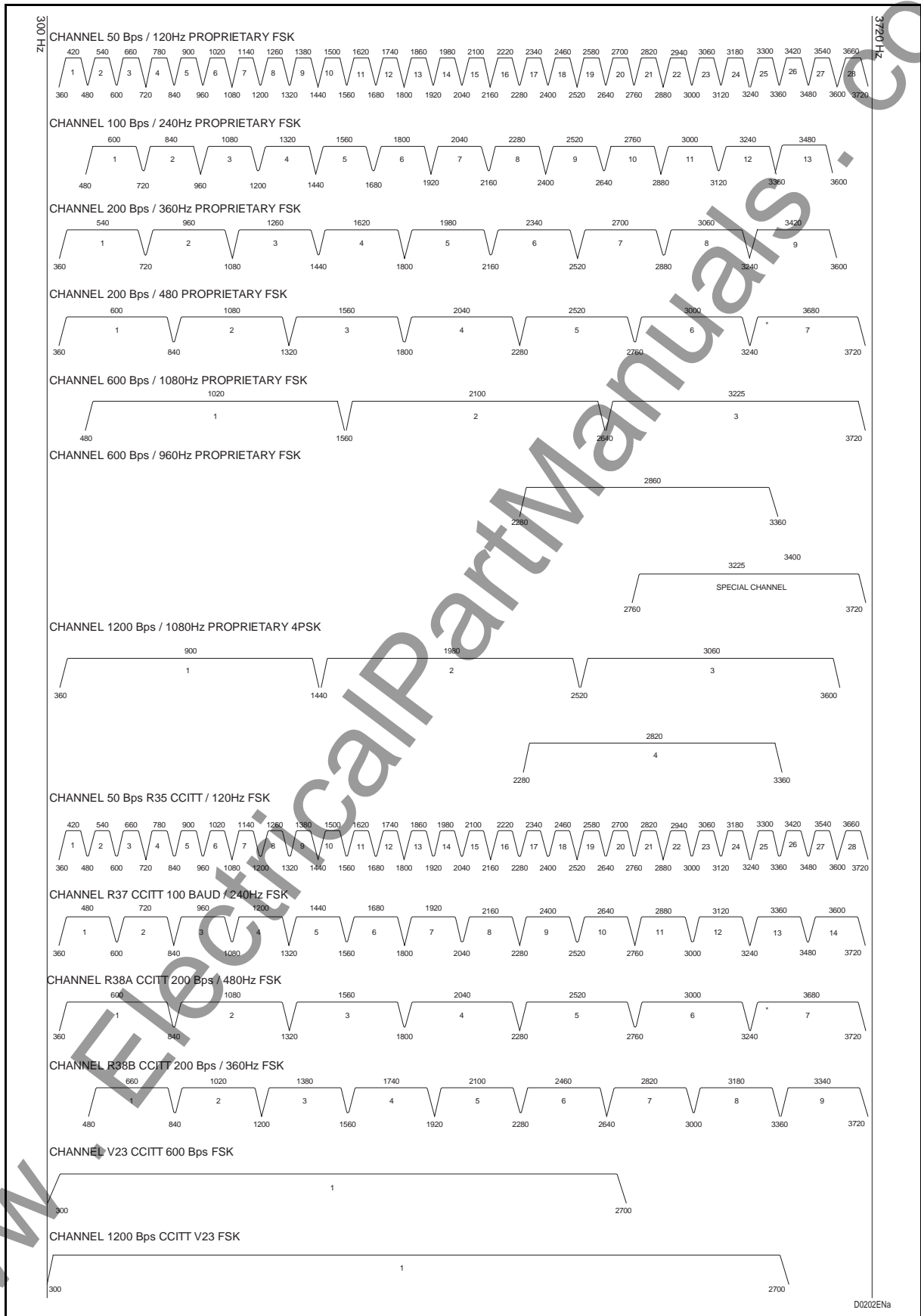

FIGURE 5 – MTU CHANNELS

D0202ENa

BLANK PAGE

www.ElectricalPartManuals.com

INSTALLATION

www.ElectricalPartManuals.com

www.ElectricalPartManuals.com

CONTENTS

1.	SHIPMENT	5
1.1	General	5
1.2	Unpacking	5
1.2.1	Preliminary verifications	5
1.2.2	Equipment unpacking	7
1.2.3	Storing and climatic condition	7
1.2.4	Equipment repackaging	7
2.	EQUIPMENT PARTS LIST	8
2.1	General	8
2.2	Subrack	8
2.3	PLC layout	8
2.3.1	Cards size	8
2.3.2	Cards position	8
2.3.3	Optional modules and accessories	9
2.4	Configuration	10
2.4.1	PLC 1790/B revision2 Configuration	10
3.	STANDARD EQUIPMENT PROGRAMMING	11
4.	INSTALLATION PROCEDURE	12
4.1	Subrack installation	12
4.1.1	general	12
4.1.2	Site Selection	12
4.1.3	Mechanical installation	12
4.2	Integration recommendations	14
4.3	EMC considerations	15
4.4	Electrical installation	15

5.	FIELD CONNECTORS	17
5.1	Allocation	17
5.2	Field connectors details	18
5.2.1	Power supply	18
5.2.2	Telegraph channels	18
5.2.3	Low frequency channel (LFS / LFS3)	19
5.2.4	Low frequency channel transit interface (INTE)	20
5.2.5	MTU data interface	21
5.2.6	Programming computer interface	22
5.2.7	INSU – Remote Command signals	23
5.2.8	PLC open collector alarms	24
5.2.9	PLC alarms	25
5.2.10	Connection to the power line	26
5.2.11	Cabinet alarm	27

MODIFICATIONS PAGE

Version	DATE	COMMENTS
A	June 1998	ORIGINAL ISSUE
B	Dec. 1998	Modification of pages 16, 17
C	Sept. 1999	New presentation + Modification of pages 4, 5, 6, 7, 8, 10, 17 to 26
D	Aug. 2002	Adding integration recommendations
E	March 2004	New presentation and introducing 1790/B revision 2
F	September 2004	Minor change, editing for 2 side printing

BLANK PAGE

www.ElectricalPartManuals.com

1. SHIPMENT

1.1 General

This chapter will drive the installation personnel into the basic procedures to be followed to unpack the containers used to transport PLC 1790/B REVISION2 terminal.

Complementary procedures apply to repack when required. Should this case apply, and then the re-utilization of the same material used for the original packing is recommended.

In order to protect the equipment from mechanical and environmental damages, the following containers should be used:

- Wood boxes for ship, aircraft and truck transportation that might take longer than 60 days.
- Cardboard boxes for aircraft or truck transportation which might take lesser than 30 days

1.2 Unpacking

1.2.1 Preliminary verifications

The following information are printed on container sides:

- Production mark
- Destination
- Net weight
- Dimensions
- ↑↑ Symbol identifying container proper position during transportation

The packing sheet inserted in a plastic bag, see detail (F) in figure 1, lists the materials inside the container.

When receiving the containers verify that no damages had happened during transportation.

Whether the contrary happens, unpack the containers (see paragraph "complexes unpacking") and contact the company or carrier representative to inform about.

Be sure that container final destination is that shown on the box.

Example of PLC Packing

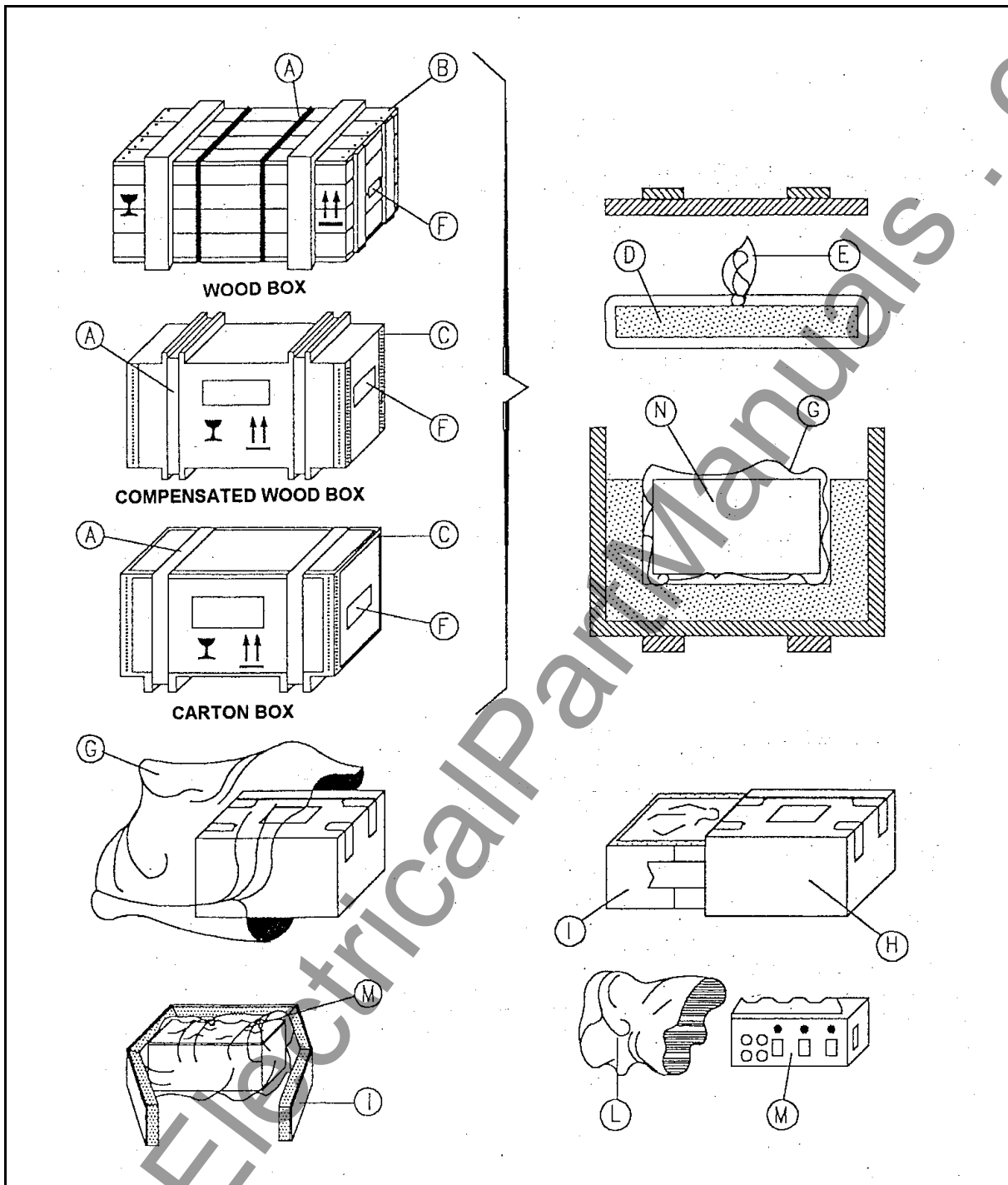

FIGURE 1 – RACK UNPACKING PROCEDURE

1.2.2 Equipment unpacking

(Refer to figure 1).

In order to unpack the equipment follow the next procedure.

- Be sure container is in the position indicated by ↑↑.
- Cut the nylon laces (A).
- Extract the nails (B) if container is a wood box or the metal staples (C) if container is a compensated wood or carton box.
- Take out the carton pre-packing (N) wound on the polyethylene tube (G).
- Take out the carton pre-packing from the polyethylene tube by cutting one end. Do not throw away the tube as it may be used for an eventual recapping.
- Cut the adhesive tape that winds round the carton box (H).
- Shift out the polyurethane foam bed (I) from the box.
- Take out (M) wound on the tube (L) cutting an end.
- Do not throw away the tube as it may be used for an eventual re-packing.
- Verify that the equipment was not damaged by the transportation; otherwise, contact the company representative.

1.2.3 Storing and climatic condition

If the equipment is not immediately installed it is necessary to store the packing as follows:

- The carton boxes must be placed inside environments with air circulation.
- The wood or plywood boxes can be placed outdoors if they are protected against rain or sun rays.

Long-term storage temperature must be within $-40\text{ °C} \div +70\text{ °C}$.

Outdoor storage period cannot exceed 12 months.

1.2.4 Equipment repackaging

(Refer to figure 1).

- Insert the complex (M) in the polyethylene tube (L) and seal it with adhesive tape.
- Set the complex on the bed (I).
- Insert the bed (I) in the box (H).
- Seal the box (H) with adhesive tape.
- Whenever it is necessary (see paragraph "General") put the pre-packing in wood or in plywood crate.
- Close the wood crate with the nails (B) and the cardboard box with the metal staples (C).
- Wind round the crate the nylon laces (A).

2. EQUIPMENT PARTS LIST

2.1 General

The PLC 1790/B REVISION2 subrack complies with standard specs DIN 41494/IEC 297-3.

Major components include extruded aluminum parts passive and are assembled with stainless steel screws.

The base subrack mechanical arrangement provides for the addition of electromagnetic compatibility (EMC) and electromagnetic interference (EMI) protections.

Finishing and mechanical contacts guarantee optimal electrical conductivity, thus ensuring proper protection against electrostatic discharges.

2.2 Subrack

The subrack is a 9-DIN Units (Dimensional UNIT = 44,45 mm).

Front flanges provide for rack mounting facilities when applicable.

Holes are positioned at 19" (1 inch = 25 mm).

Transversal brackets and guides facilitate cards positioning within the subrack.

Subrack cabling is realized by means of a single Motherboard that is a 9 DIN Units printed circuit card.

2.3 PLC layout

2.3.1 Cards size

6U electronic cards are used: dimensions: 233,35 x 160 mm.

All cards, included the subrack motherboard, comply with class 3 specs.

2.3.2 Cards position

Refer also to FIGURE 2:

Position	Code	Description	Acronym	Max. Qty	Note
2	478.410.000	Power Supply Unit	ALIM	1	
14 – 26	411.410.034	Low Frequency Section	LFS	2	(1)
14 – 26	411.410.035	Low Frequency Section with extension up to 3 I/O telegraph channels and 1200 Bps data rate modem in superimposed band.	LFS3	2	(1)
14 – 26	411.412.011	Transit Interface	INTE	2	(1)
36	299.704.331	Cover Plateanel		1	
40	411.410.039	High Frequency Modem	MODAF	1	
45 – 55	474.412.008	20W Amplifier	AMPL	2	
65	474.412.009	TX Line Interface	INTX	1	
76	474.412.010	RX Line Interface	INRX	1	

TABLE 1 – UNITS COMPOSITION IN THE PLC 1790/B REVISION2 SUBRACK

(1) Units in alternative

PLC FRONT VIEW

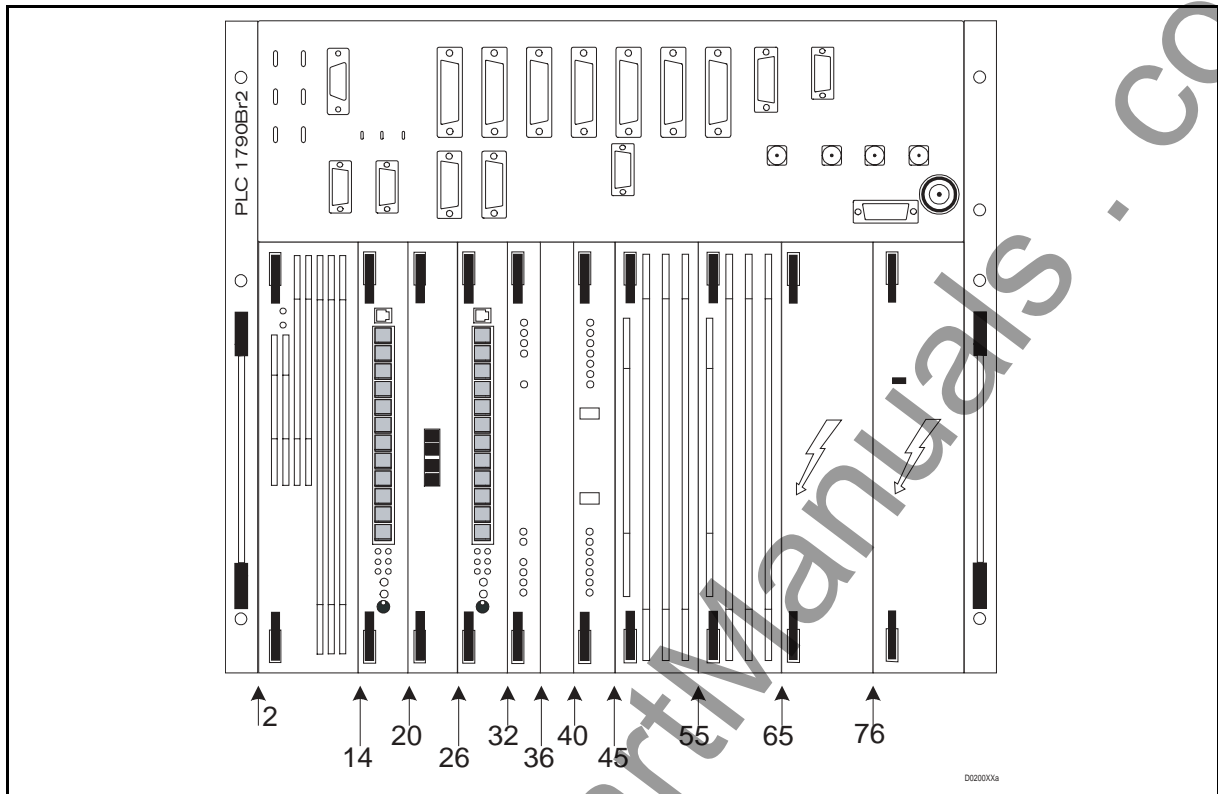

FIGURE 2 – PLC 1790/B REVISION2 SUBRACK FRONT VIEW

2.3.3 Optional modules and accessories

MODULE

Position	Code	Description	Acronym	Max. Qty
20	474.415.026	Universal Call Converter	CCUN	1
32	411.410.027	Supervisory Interface	INSU	1

TABLE 2 – OPTIONAL MODULE

ACCESSORIES

Code	Description	Acronym
474.449.808	Extension card	
299.704.331	6U 4TE Full cover panel	
299.704.333	6U 6TE Full cover panel	
299.704.332	6U 10TE Full cover panel	
013.200.015	Service telephone	
049.911.070	LF test cable	
041.994.480	HF test cable	
041.994.489	Rack terminal strip (LF)	
284.904.006	Plant connector support (LF)	
041.994.483	Rack coaxial cable connector (HF)	
588.467.053	Plant coaxial connector support	

TABLE 3 – OPTIONAL ACCESSORIES FOR PLC 1790/B REVISION2

2.4 Configuration

PLC 1790/B revision2 equipment has the possibility to be configured using always the same subrack housing different cards, according to the field demand.

Few rules has to be taken into account:

- Single Channel 4 kHz stepping (on HF 4 kHz TX + 4 kHz RX)
- Double Channel 4 + 4 kHz stepping (on HF 8 kHz TX + 8 kHz RX)
- 10, 20 or 40 W pep HF output power

2.4.1 PLC 1790/B revision2 Configuration

table 4 and table 5 show the required cards for the different PLC 1790/B REVISION2 configuration.

CARD	SINGLE CHANNEL			DOUBLE CHANNEL			S/RACK POS.
	10 W	20 W	40 W	10 W	20 W	40 W	
ALIM	√			√			2
INSU	√ (OPTIONAL)			√ (OPTIONAL)			32
MODAF	√			√			40
AMPL			√			√	45
AMPL	√	√	√	√	√	√	55
INTX	√			√			65
INRX	√			√			76
LFS 0	√			√			14
LFS 1	√			√			26
LFS 3	√ (ALTERNATIVE)			√ (ALTERNATIVE)			26 or 14
INTE	√ (ALTERNATIVE)			√ (ALTERNATIVE)			26 or 14
CCUN	√ (OPTIONAL)			√ (OPTIONAL)			20

TABLE 4 – PLC CONFIGURATION

ACCESSORIES		
UNIT	QTY.	NOTE
Service telephone	1	
Front cover plate_ (20 mm)	1	Alternative INSU
Front cover plate_ (30 mm)	1	Alternative LFS , CCUN
Front cover plate_ (50 mm)	1	Alternative AMPL
Extension card	2	

TABLE 5 – ANCILLARY ACCESSORY (OPTIONAL)

3. STANDARD EQUIPMENT PROGRAMMING

Whether there were no indications about the equipment programming, the following standard configuration referred to 10 W single channel will be performed:

- Channel step 4 kHz
- Speech band 300 ÷ 2000 Hz
- Telegraph band 2160 ÷ 3480 Hz
- Signaling 3600 ÷ 3720 Hz
- Signaling type FSK
- MTU disabled
- Signaling alarm 5 dB under nominal level
- TX power alarm 3 dB under nominal level
- RX Pilot failure 5 dB under nominal level
- S/N ratio alarm 11 dB

Selection of operating frequencies is performed through a PC supported programming procedure and soldering straps.

The programming procedure can be carried out in the factory, under customer indications or on site before the installation phase.

For further information refer to the chapter related to start - up.

4. INSTALLATION PROCEDURE

Installation activities can be divided in the following phases:

- Equipment mechanical mounting
- Electrical connections (power supply, LF cable, HF cable....)

The following paragraphs will help the personnel proposed to the installation to carry out the above-mentioned steps.

4.1 Subrack installation

4.1.1 general

Before material delivery date, the infrastructure where the equipment will be installed should be ready. It is also important that the main power supply as well the PLC power supply will be guaranteed in a continuous way.

4.1.2 Site Selection

When is made the selection of the site the following parameters should be taken into account:

- Rack dimensions
- Number of racks
- Ceiling height, no lower than 2.5 m. from floor
- Battery Charger capacity
- Environment condition
- Main earth network

4.1.3 Mechanical installation

Once all requirements related to the installation site have been verified it is possible to proceed to the installation.

PLC 1790/B REVISION2 SUBRACK MOUNTING INTO THE RACK.

Subrack fixing operations are as follows:

- Select the position into the subrack
- **The minimum distance to leave between the PLC and the other equipment installed into the same rack must be, at least, of 2 din unit, see Erreur ! Source du renvoi introuvable.**figure 3.
- Fix the nuts on the rack
- Insert the subrack in the rack and fix it with the supplied bolts or screws

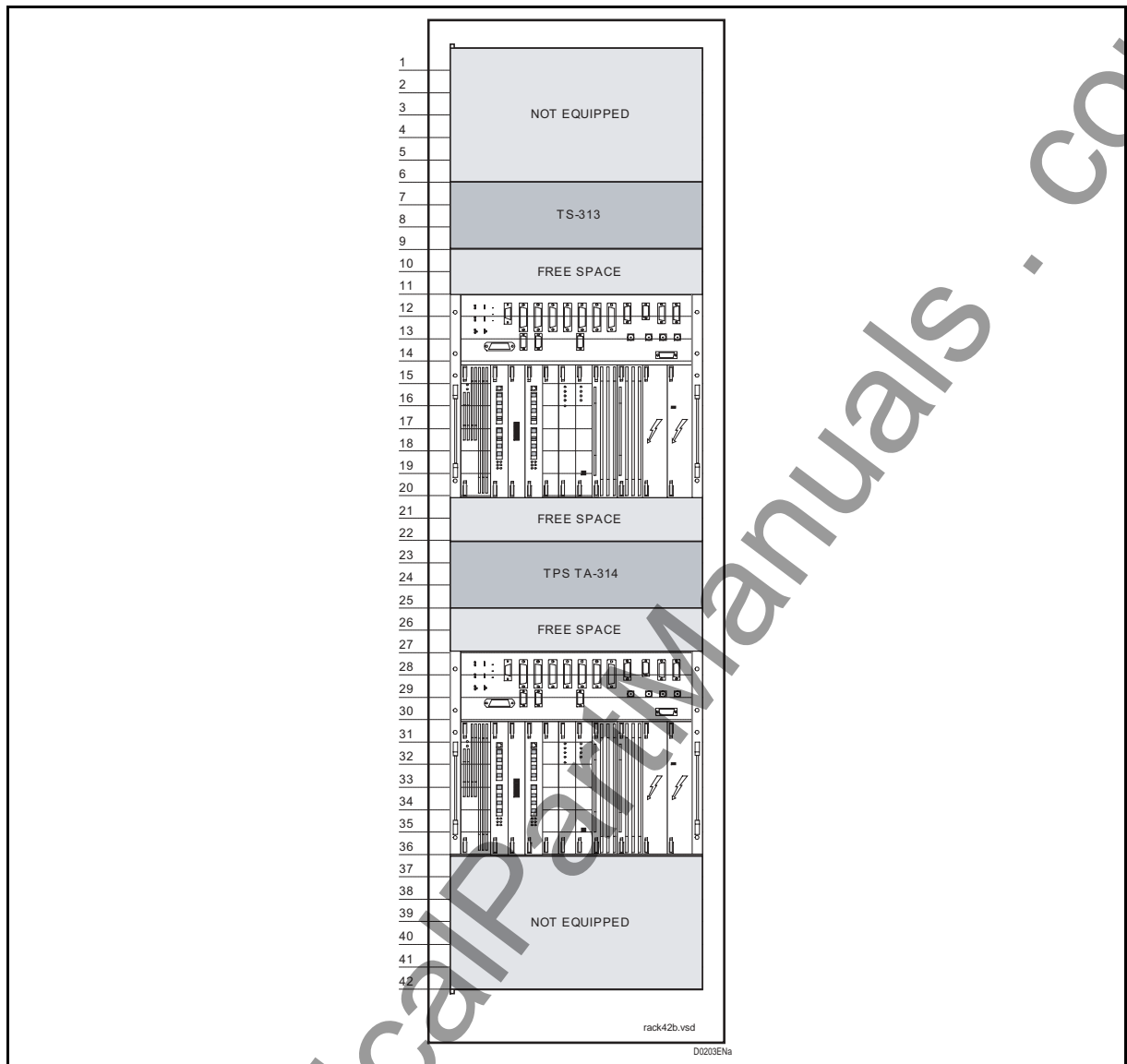

FIGURE 3 – PLC INSTALLATION EXEMPLE

4.2 Integration recommendations

PRINCIPLE OF POWER SUPPLY AND R.F. CABLES CONNECTION

In order to guarantee the best EMC protection, the following rule must be respected:

Power cable and R.F. cable must be linked on a same terminal block near the cubicle cables entrance.

Ground reference must be performed by a wire of 16-mm² section or a copper braid.

Protection devices must be positioned on this terminal block.

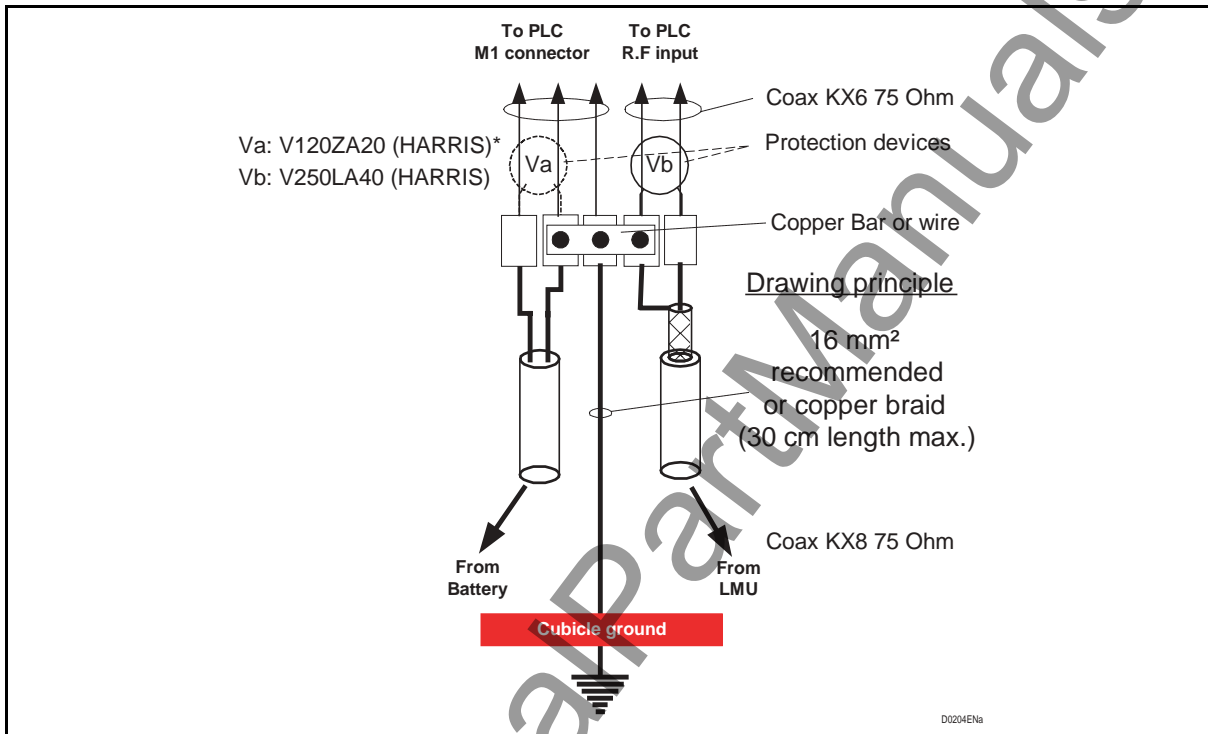

FIGURE 4 – INTEGRATION RECOMMENDATION

NOTE: As protection for disturbances coming from power supply PLC1790/B revision2 has been Improved with adjunction of varistance and filter the protection Va is not mandatory

4.3 EMC considerations

EMC: ELECTROMAGNETIC COMPATIBILITY

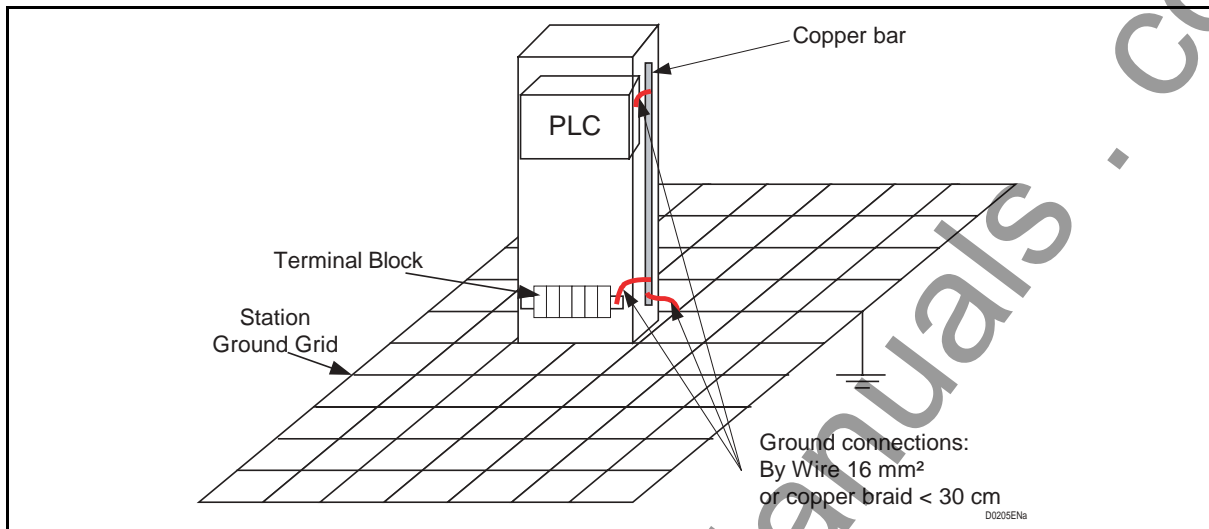

FIGURE 5 – EMC RECOMMENDATION

4.4 Electrical installation

RACK GROUND CONNECTION

Ground connections guarantee people safety and proper equipment operation.

Due to these reasons the grounds supplied by customer must be according to IEC recommendations.

Wires section for ground connections in transmission/switching equipment facilities, must be determined according to the indications contained in CEI-64-8 standard;

table 6, reports ground cable sections to be used according to associated current values.

CABLE SECTION mm ²	ASSOCIATED CURRENT A _{DC}
16	I < 50
25	50 < I < 70
70	130 < I < 160.
95	160 < I < 180.
120	180 < I < 1000.

TABLE 6 – GROUND CABLE SECTION

NOTE: The indicated sections are related to a maximum length of 50 m

ELECTRICAL CONNECTIONS

The electrical connection of the PLC 1790/B revision2 is done through connectors placed on the upper part of the subrack, see chapter Start- up.

The connector types to use for the different functions are shown in the documentation (subrack material list)

All connectors once checked, are inserted in the dedicated place and blocked

Before begin the electric installation, the user has to define, according to the equipment configuration and the required service to utilize, the type and quantity of cable to lay down.

The next table will show the typical cable used for a standard installation of two channels apparatus:

Service	Cable type	From connector
Shelve ground	6 MM ²	sub-rack
Power supply	3 x 2.5 MM ²	m1
Telegraph service	2 x (6 pairs) x 0.6MM ²	m32 & m10 / m40 & m41
Alarm	1 x (15 pairs) x 0.6MM ²	m8 & M37
LF signals	2 x (20 pairs) x 0.6MM ²	m2 & m3
INSU r.c.	2 x (6 pairs) x 0.6MM ²	m37
Data signals	computer cable	m4 & m5

TABLE 7 – INSTALLATION CABLE

Once defined the cables to use proceed as follow

- Lay down the cables between the equipment and the destination point; in same case this operation should be done before the mechanical installation
- Insert the cable inside the equipment through the side open hole;
- Using the supplied connectors make the required connections. All the connectors are soldering type;
- Connect the equipment with the station ground;
- Insert the connectors to the respectively sockets
- Ensure that the power supply is off and then connect the power source

Before switching on the equipment read carefully the COMMISSIONING MANUAL

5. FIELD CONNECTORS

5.1 Allocation

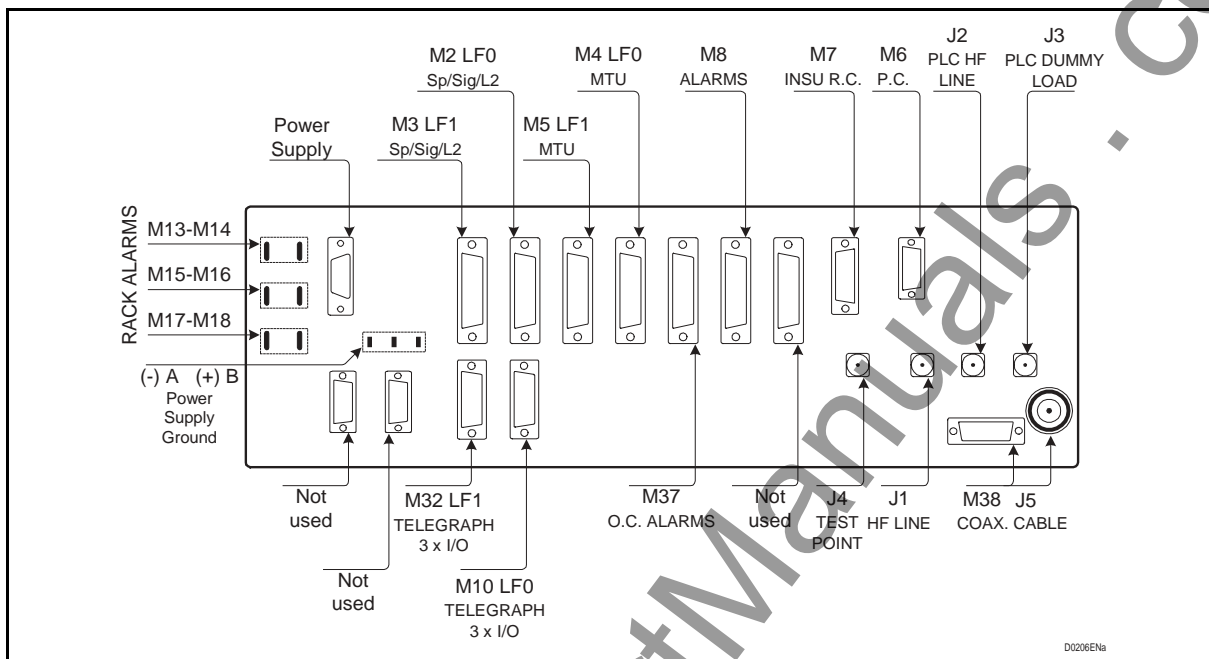

FIGURE 6 – FIELD INTERCONNECTION PANEL

The field connectors of the PLC 1790/B REVISION2 are located on the upper side of the mother board in front of the operator in order to facilitate the installation and maintenance activities.

Each connector used for the Low Frequency signal is identify by a code Mx except for the High Frequency signals coaxial connectors have been used identified by the code Jx.

A few straps are present on the motherboard backside in order to program the power source input and to display the general alarm on M13 to M18.

Closing the strap "A" the negative polarity of the power source will be grounded, closing the strap "B" the positive polarity of the power source will be grounded, opening both A and B straps the power source will be floating.

Using the connectors M13, M15 and M17 the PLC general alarm can be connected and displayed by the rack lamp (if available).

The connectors M14, M16 and M17 can be programmed (see M/Board presetting on Commissioning manual,

In the following all the field connectors are presented showing the signals supported by each of them.

5.2 Field connectors details

5.2.1 Power supply

- PIN 1 Negative
- PIN 2 Ground Pole
- PIN 3 Positive Pole

NOTE: Ground pole should be connected to next available earth point independently of rack ground connection made according to § 4.2

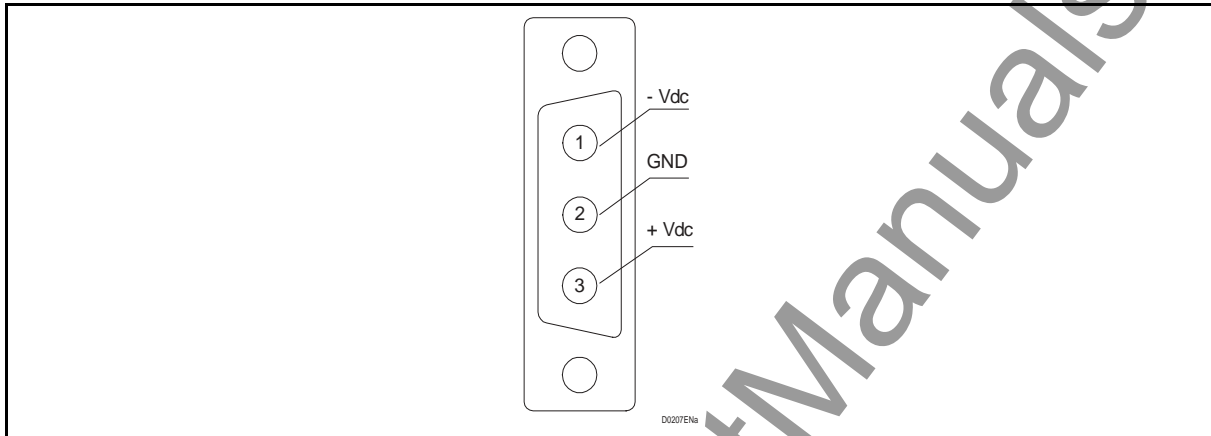

FIGURE 7 – M1 ⇨ POWER SUPPLY

5.2.2 Telegraph channels

- PIN 1-2 Signal Input telegraph channel 1
- PIN 3-4 Signal Output telegraph channel 1
- PIN 5-6 Signal Input telegraph channel 2
- PIN 7-8 Signal Input telegraph channel 3 (only LFS-3)
- PIN 12-13 Signal Output telegraph channel 2
- PIN 14-15 Signal Output telegraph channel 3 (only LFS-3)

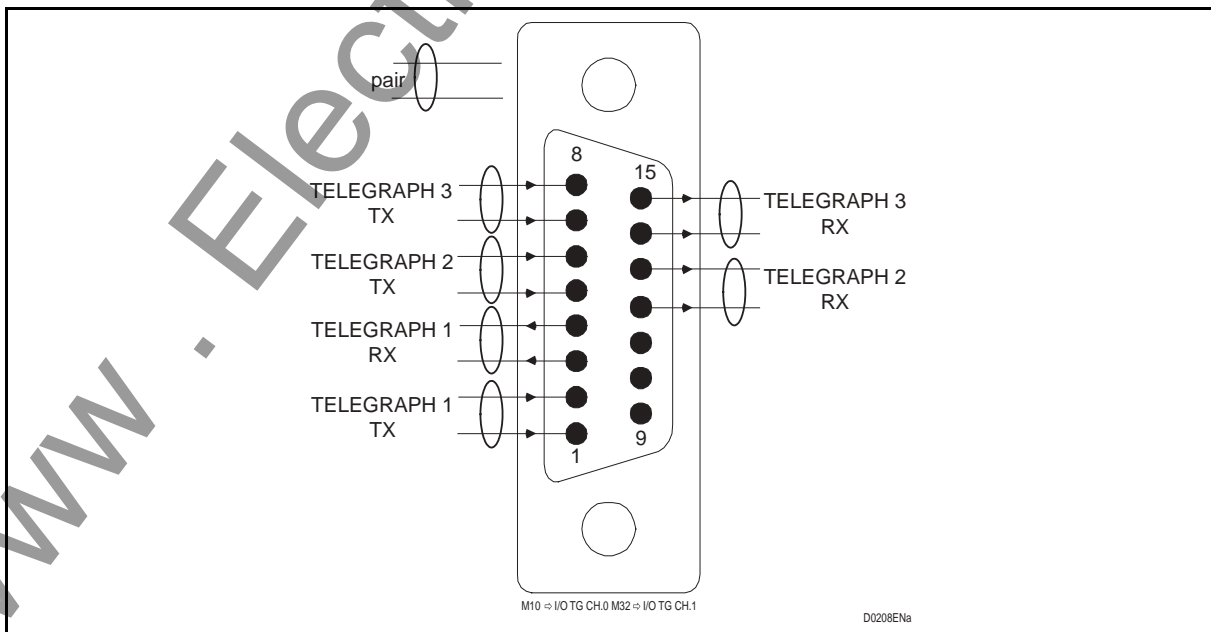

FIGURE 8 – INPUT / OUTPUT TELEGRAPH CHANNELS

5.2.3 Low frequency channel (LFS / LFS3)

- PIN 1-4 Not Used
- PIN 2-3 Output Speech 4 wires RX or 2 wires TX/RX
- PIN 5-6 Input Speech 4 wires TX
- PIN 7-13 LF service suppression criteria RX (optocoupled signal)
- PIN 8 "E" wire signalling main output (ground reference)
- PIN 9 "M" wire signalling main input (ground reference)
- PIN 10 Programmable, by switch, as LF alarm or auxiliary "E" wire (ground reference)
- PIN 11 LF Signalling alarm (ground reference)
- PIN 12 Compandor exclusion (Ground criteria)
- PIN 14-15 Line-2 Output
- PIN 16-17 Not Used
- PIN 18-19 Line-2 Input
- PIN 20-21-22 LF FSK Signalling Alarm, changeover free voltage contacts
- PIN 23-24 LF service suppression criteria TX (optocoupled signal)
- PIN 25 2/4 speech wires automatic exchange (ground criteria)

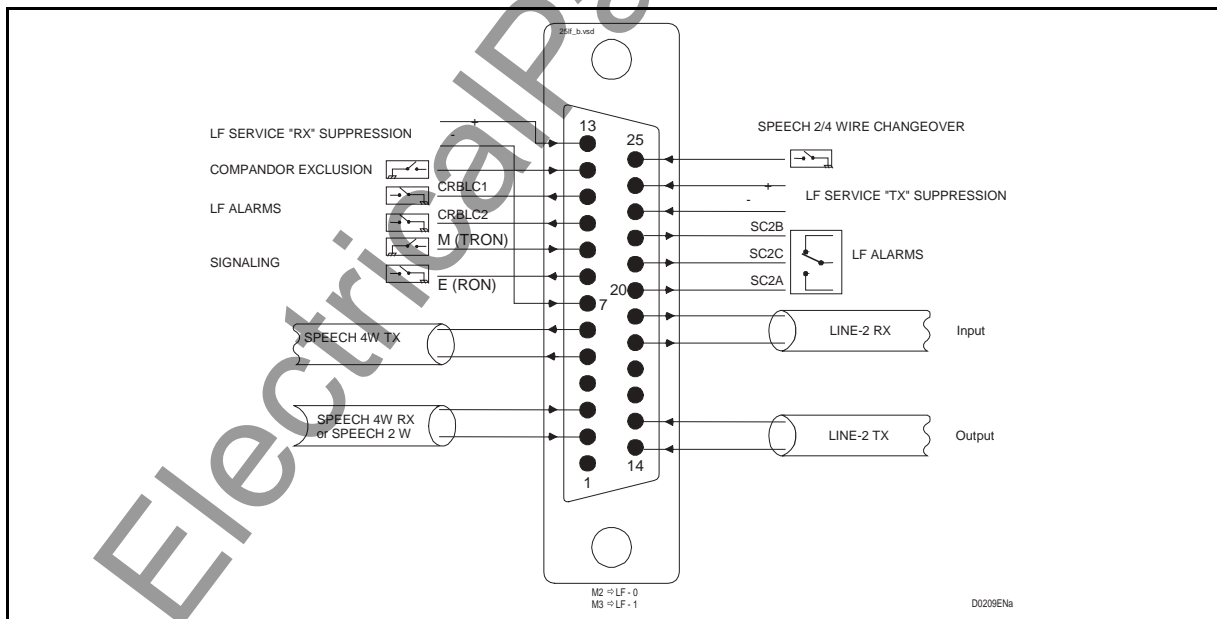

FIGURE 9 – LFS SERVICE OUTPUT CONNECTOR

5.2.4 Low frequency channel transit interface (INTE)

- PIN 1-4 INTE Tx channel 0
- PIN 14-15 INTE Rx channel 1
- PIN 16-17 INTE Rx channel 0
- PIN 18-19 INTE Tx channel 1

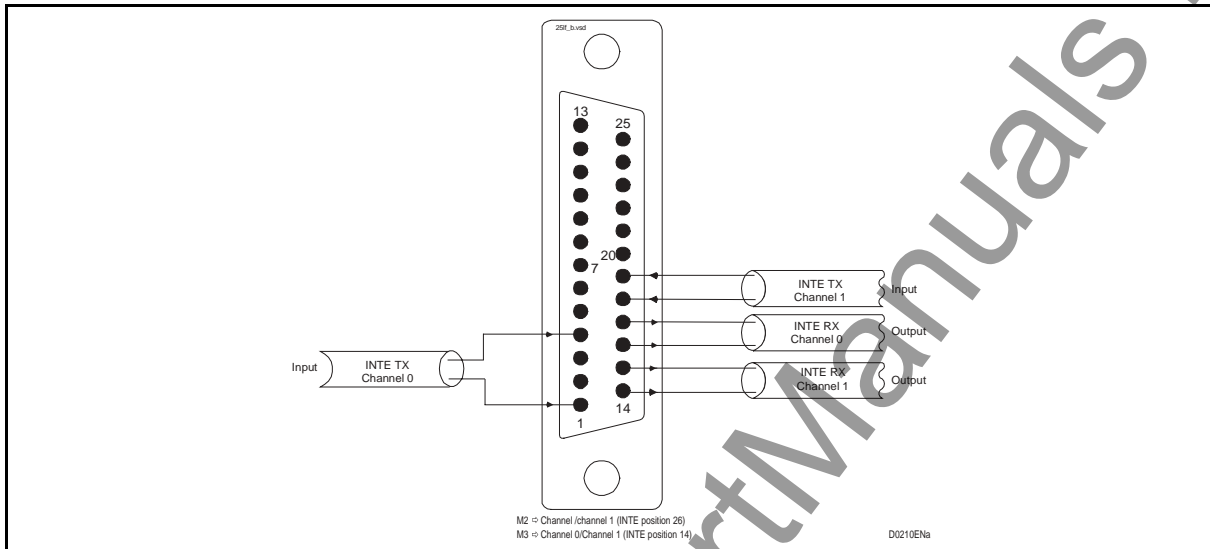

FIGURE 10 – INTE SERVICE INPUT/OUTPUT CONNECTOR

5.2.5 MTU data interface

RS-232 data interface available in both PLC channels for low rate data communication

- PIN 1 Mechanical ground
- PIN 2 TD Transmission Data
- PIN 3 RD Reception Data
- PIN 4 RTS Request To Send
- PIN 5 CTS Clear To Send
- PIN 6 DSR Data Set Ready
- PIN 7 GND Electric Ground
- PIN 8 DCD Data Carrier Detector
- PIN 20 DTR Data Terminal Ready

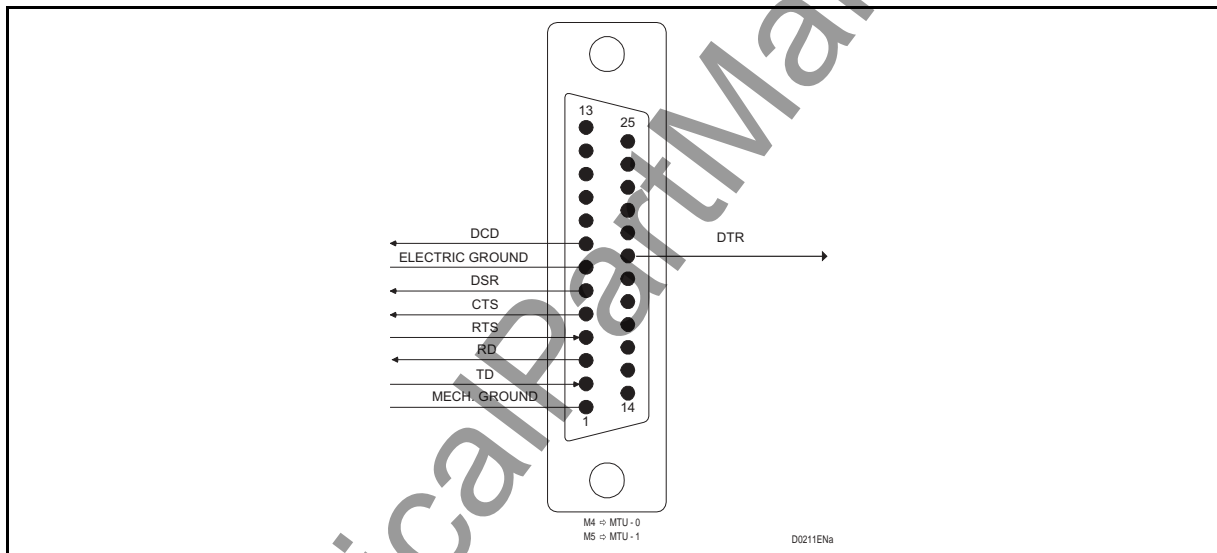

FIGURE 11 – MTU RS-232 INTERFACE

5.2.6 Programming computer interface

RS -232 data interface for programming console

- PIN 2 TD Transmission Data
- PIN 3 RD Reception Data
- PIN 5 – Electric Ground
- PIN 9 DTR Data Terminal Ready

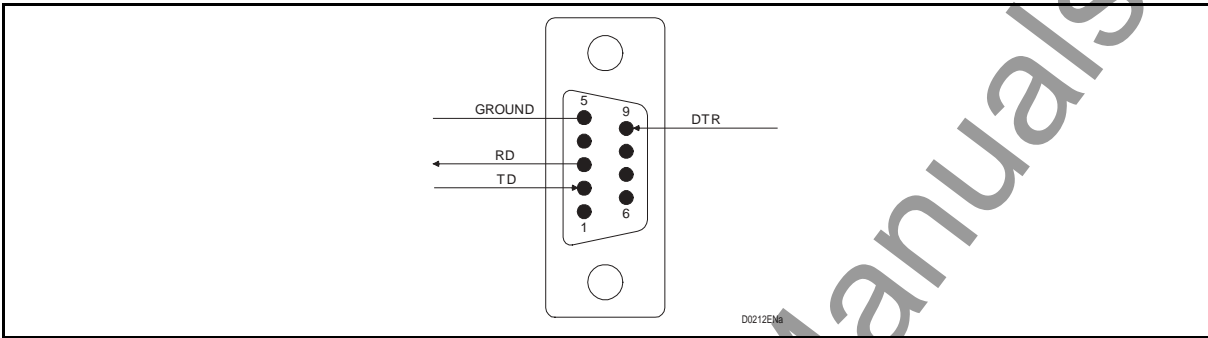

FIGURE 12 – M6 COMPUTER INTERFACE (PROGRAMMING / MAINTENANCE)

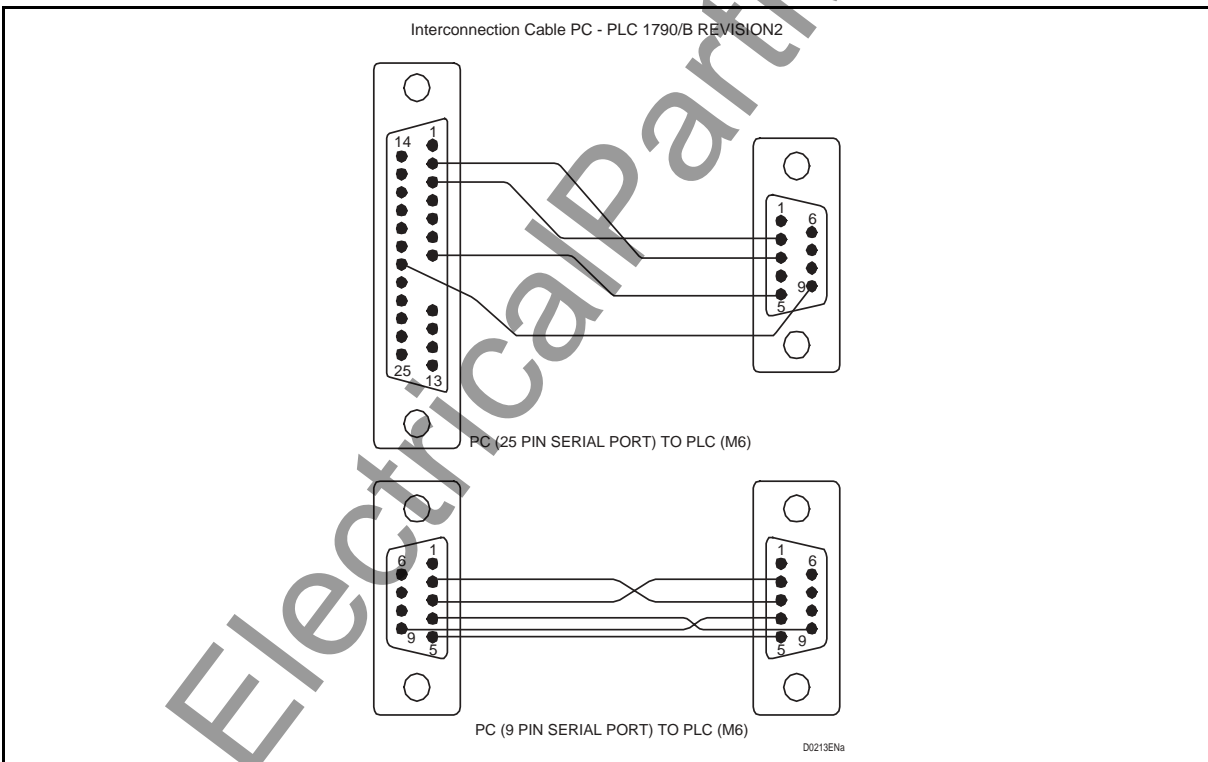

FIGURE 13 – PC CABLE

5.2.7 INSU – Remote Command signals

- PIN 1 Ground
- PIN 2 Remote command 3 output (ground reference)
- PIN 3 Remote command 4 input (ground reference)
- PIN 4-5-6 Remote command 2 output (free voltage contact changeover)
- PIN 7-8-12 Remote command 1 output (free voltage contact changeover)
- PIN 9 Remote command 1 input (ground reference)
- PIN 10 Remote command 2 input (ground reference)
- PIN 11 Remote command 3 input (ground reference)
- PIN 13 Remote command 4 output (ground reference)

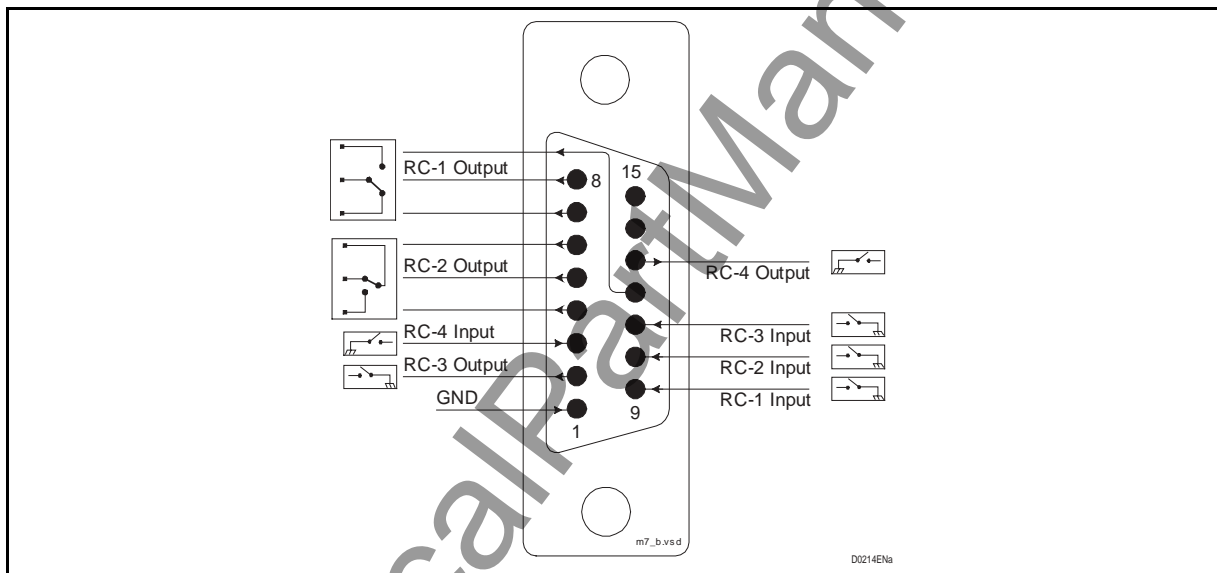

FIGURE 14 – M7 ⇨INSU - RC SIGNALS

5.2.8 PLC open collector alarms

- PIN 2 Power Supply alarm
- PIN 5 Transmission carrier
- PIN 8 Reception carrier failure
- PIN 11 PLC general alarm
- PIN 14 LFS 0 signaling alarm
- PIN 17 LFS 1 signaling alarm
- PIN 20 LFS section alarm for S/N
- PIN 23 Loop status indication (local or remote loop test)
- PIN 25 Ground

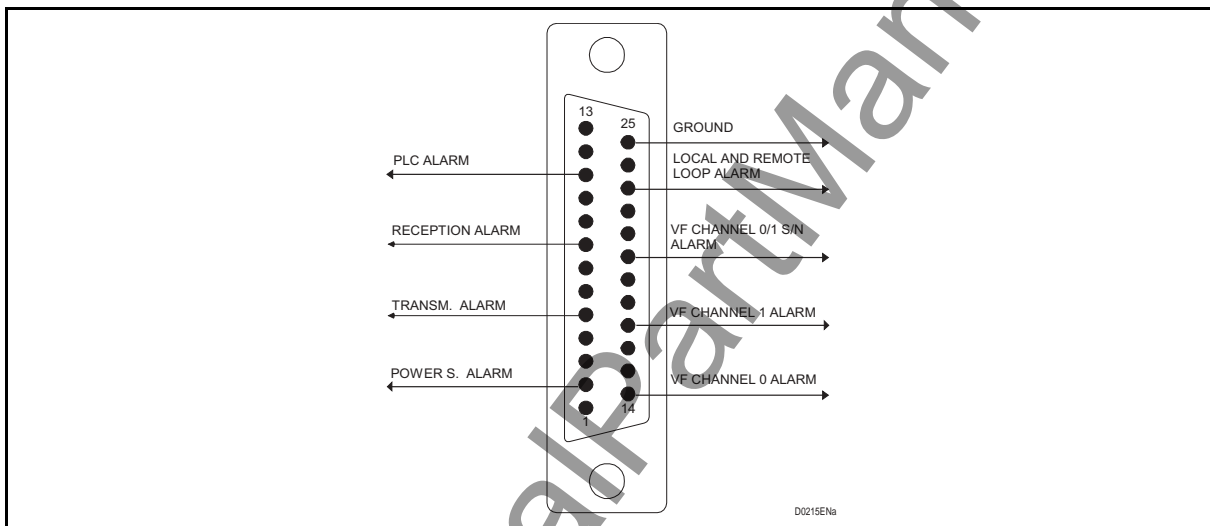

FIGURE 15 – M37⇨ OPEN COLLECTOR ALARMS

NOTE: These signals are available only when the INSU card is provided

5.2.9 PLC alarms

PLC alarms are provided by free changeover relay contacts

- Power Supply
 - PIN 1-2-3 Power supply alarm for each faulty voltage (-36, ±15, ±5 Vdc)
- Transmission carrier
 - PIN 4-5-6 Transmission carrier level reduction of 5 dB or more
- Receiver section channel 0/1
 - PIN 7-8-9 Carrier failure
 - PIN 19-20-21 S/N
- Alarm summary
 - PIN 10-11-12 This PLC1alarm is provided for any other alarm in the equipment (OR)
- Channel 0
 - PIN 13-14-15 Audio frequency alarm for receiving signaling level reduction of 5 dB or more
- Channel 1
 - PIN 16-17-18 Audio frequency alarm for receiving signaling level reduction of 5 dB or more
- Loop function
 - PIN 22-23-24 Warning signal in presence of local or remote loop function

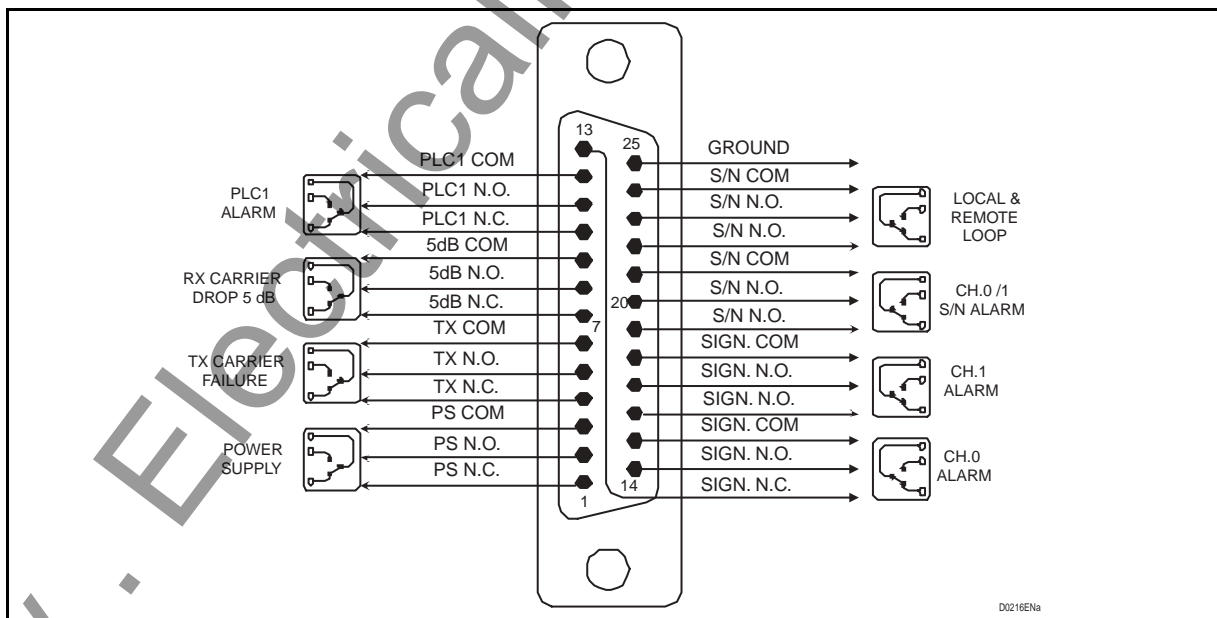

FIGURE 16 – M8 ⇨ ALARMS

5.2.10 Connection to the power line

PLC 1790/B REVISION2 equipment can be connected to the media using 2 wires interface.

In the following are shown the standard connectors

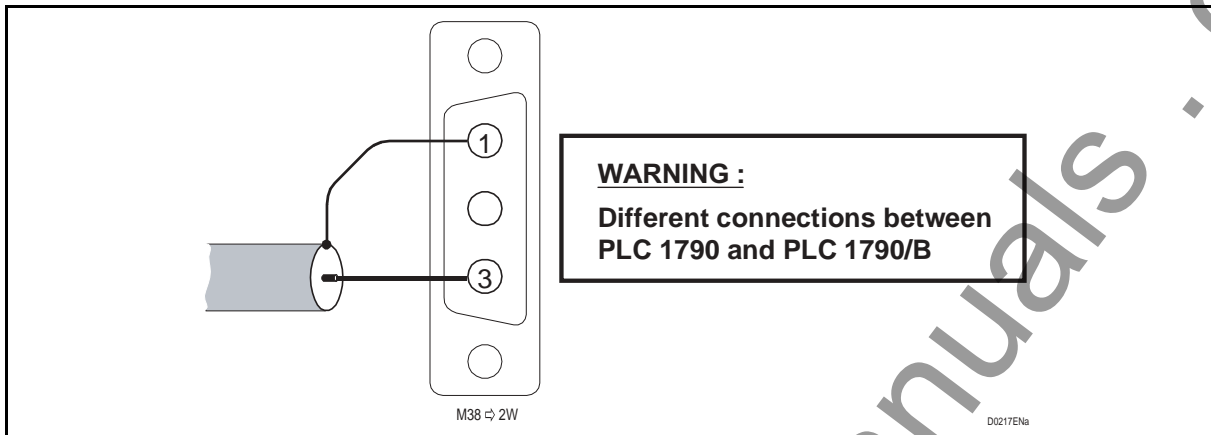

FIGURE 17 – HF CONNECTORS

A coaxial connector J5 (in parallel to 2 Wires M38 connector) is available in order to connect the line match unit through a coaxial cable terminated with a coaxial connector.

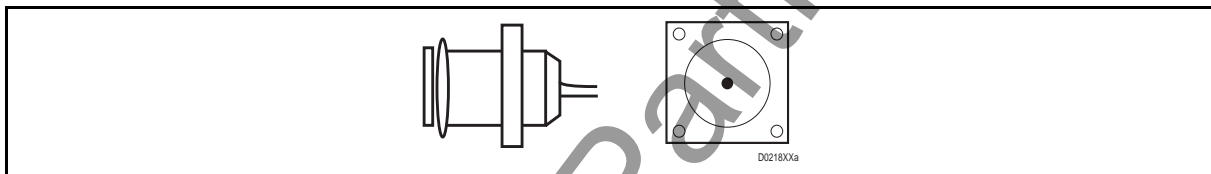

FIGURE 18 – J5 PLC HF OUTPUT COAXIAL CONNECTOR

J1, J2 and J3 are coaxial connectors in order to terminate on dummy load (J2-J3) or to connect (J2-J1) the line match unit through J5 or M38 connectors

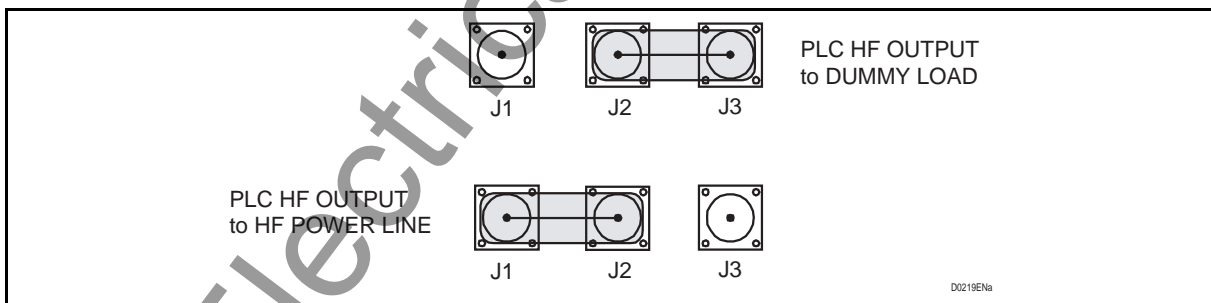

FIGURE 19 – HF OUTPUT CONNECTIONS

J4 coaxial connector is a high frequency test point that can check the transmission and receiver signals using a 75-ohm level meter decoupled by a 35 dB attenuator

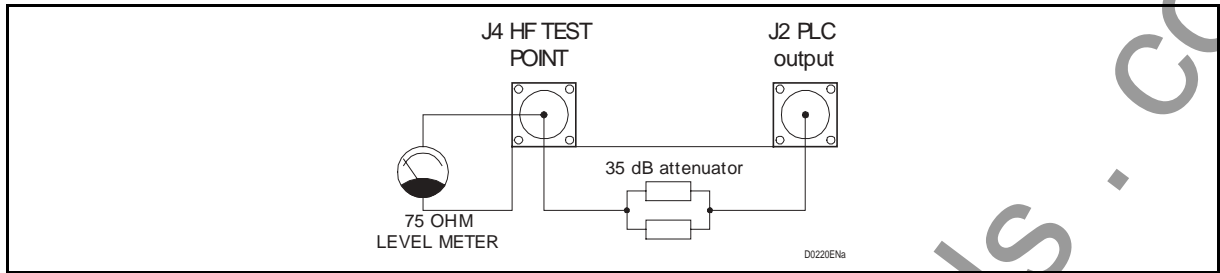

FIGURE 20 – HF TEST MEASUREMENT CONNECTORS

5.2.11 Cabinet alarm

Two changeover free contacts alarm are available to connect and show the summary of alarms for example using a lamp on the top of the cabinet (if any) and also to send a remote alarm to Scada.

The type of alarm coming in the summary (OR) PLC1 and PLC 2 is independently programmable.

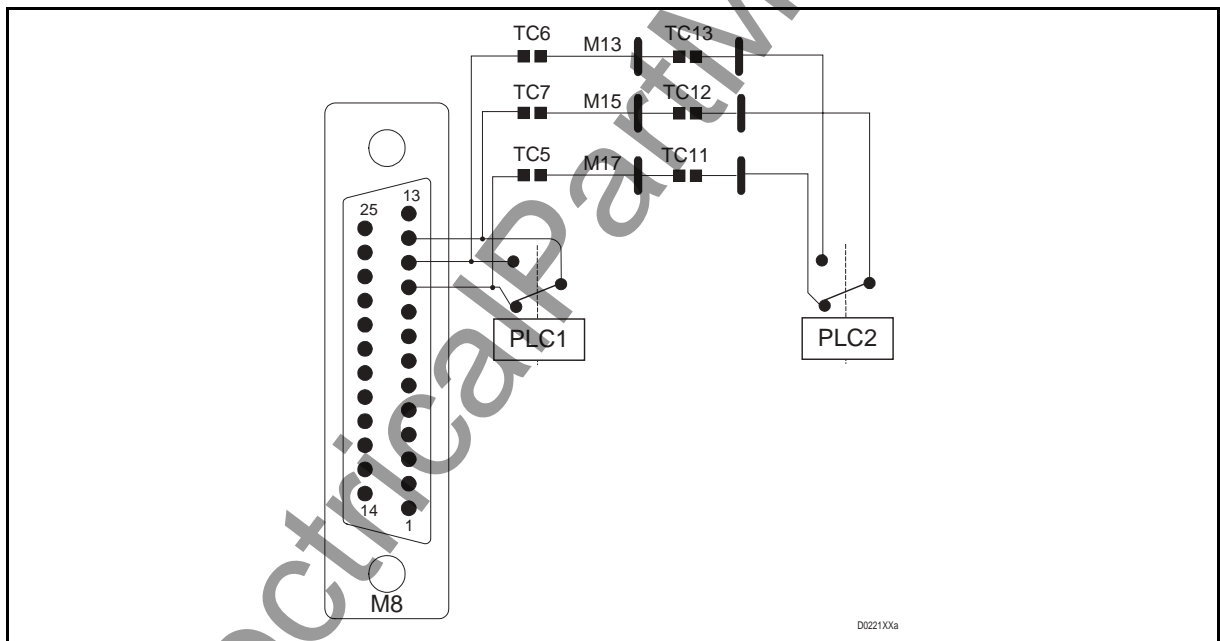

FIGURE 21 – CABINET ALARM CONNECTOR

BLANK PAGE

www.ElectricalPartManuals.com

FUNCTIONAL DESCRIPTION

www.ElectricalPartManuals.com

www.ElectricalPartManuals.com

CONTENTS

1.	GENERAL	4
1.1	LF interface	6
1.2	HF Signal elaboration	6
1.3	HF Power section	7
1.4	Supervision interface	7
1.5	PC interface	7
2.	EQUIPMENT ARCHITECTURE	8
3.	FUNCTIONS AND INTERFACES DESCRIPTION	10
3.1	PLC 1790/B Revision2 interconnection facilities	10
4.	MODULE DESCRIPTION	12
4.1	Power Supply Unit (ALIM) 478.410.000	12
4.1.1	Introduction	12
4.1.2	Description	12
4.1.3	Power Supply block diagram	13
4.2	Low frequency section (LFS) 411.310.034	14
4.2.1	Introduction	14
4.2.2	Description	14
4.2.3	LFS block diagram	18
4.3	Transit interface (INTE) 474.412.011	19
4.3.1	Introduction	19
4.3.2	Description	19
4.3.3	INTE Block diagram	19
4.4	Universal Call Converter (CCUN) 474.415.026	20
4.4.1	Introduction	20
4.4.2	Description	20
4.4.3	CCUN Block diagrams	24
4.5	High frequency modem (MODAF) 411.410.039	26
4.5.1	Introduction	26
4.5.2	Description	26
4.5.3	Common part	27
4.5.4	MODAF Block diagram	27
4.6	20W Amplifier (AMPL) 474.412.008	28
4.6.1	Introduction	28
4.6.2	Description	28
4.6.3	Amplifier Block diagram	29

4.7	Transmission Line interface (INTX) 474.412.009	30
4.7.1	Introduction	30
4.7.2	DESCRIPTION	30
4.7.3	INTX Block diagram	30
4.8	Reception interface (INRX) 474.412.010	31
4.8.1	Introduction	31
4.8.2	Description	31
4.8.3	INRX Block diagram	32
4.9	Programmable supervision Interface (INSU) 411.410.027	33
4.9.1	Introduction	33
4.9.2	Description	33
4.9.3	INSU Block diagram	34

MODIFICATIONS PAGE

Version	DATE	COMMENTS
A	June 1998	ORIGINAL ISSUE
B	Dec. 1998	Modification of pages 8, 9, 11, 13, 14, 16, 18, 19, 20, 21, 22, 26, 29, 31, 33, 34, 36
C	Sept. 1999	New presentation + Modification of page 8
D	March 2004	New presentation + Description of the PLC1790B Revision 2
E	Sept. 2004	Minor change, editing for 2 side printing

BLANK PAGE

www.ElectricalPartManuals.com

1. GENERAL

The following description makes reference to the PLC block diagram of figure 1.

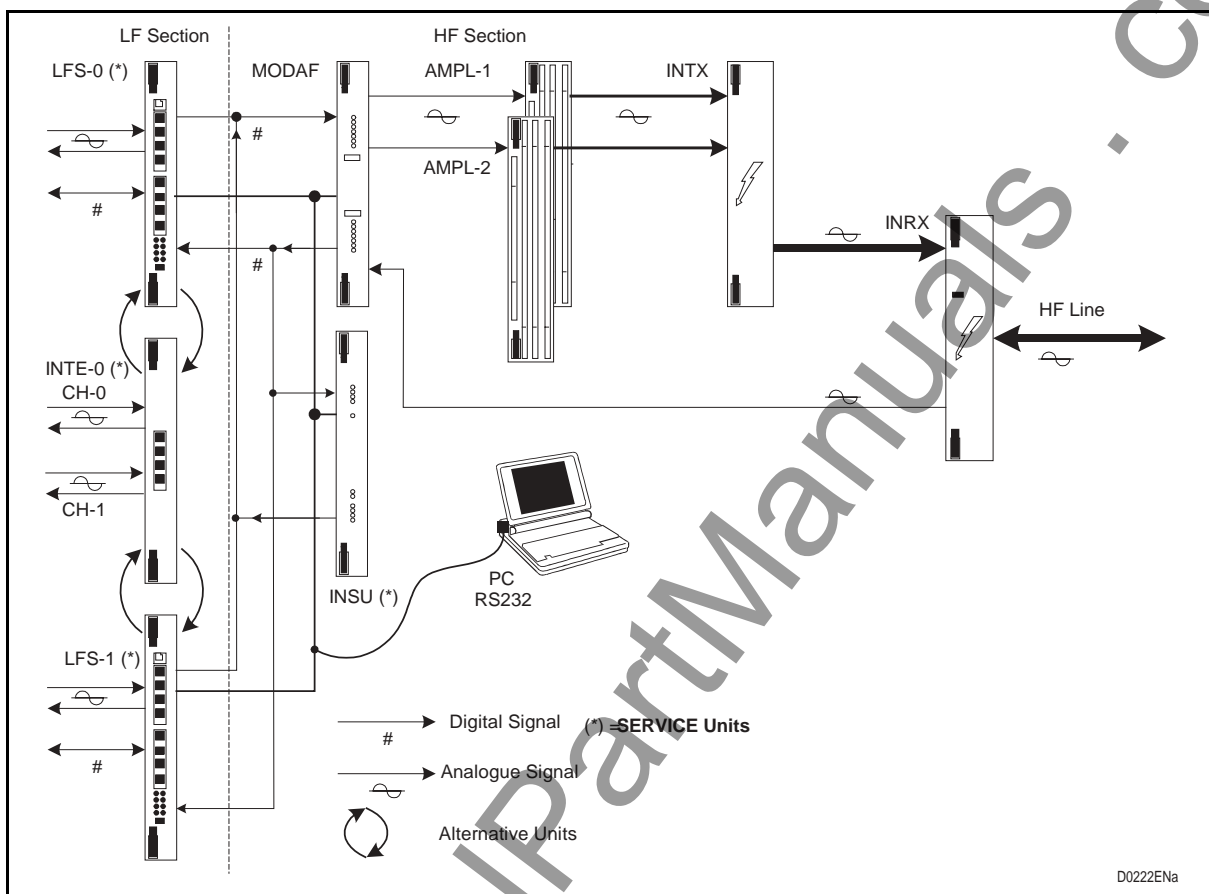

FIGURE 1 – PLC 1790/B REVISION2 FUNCTIONAL DIAGRAM

We can define three main blocks:

1. LF Interface (SERVICE)
2. HF Signal elaboration
3. HF Power SECTION

Which are integrated by:

4. Supervision interface
5. PC interface

Each block is presented in the following pages

1.1 LF interface

This section involves three different cards:

LFS	Low Frequency Section and its optional daughter board
INTE	Transit Interface
CCUN	Universal Calling Converter (optional)

The LFS manages all the LF services such as Speech & Signaling, Telegraph service, Low Speed Modem and Transit Interface. The analogue inputs are converted by A/D components; the digital signals are further elaborated by the DSP, which in frequency division techniques adds all the useful signals coming from the field, in order to build a unique bit stream that is transferred to the HF section.

Vice versa, on the reception path the digital signals coming from the HF side are elaborated, converted by D/A component and sent to the analogue interface.

LFS card provides the equalization function of RX frequency band using 8 tones transmitted within 300 ÷ 3720 Hz transmitted by the remote PLC 1790C equipment and compared with the same frequencies stored in the local LFS card.

A stored programmable corrector is present on the line L2 in order to perform the equalization of the nominal frequency band 300 ÷ 3720 Hz of a cable which is used to connect the remote equipment.

A LFS daughter card can be equipped to perform a 1200 bps over-voice frequency band modem or up to 3 input-output telegraph channel interfaces.

According to the equipment configuration up to two LFS cards can be equipped. As optional the LFS can be completed with the CCUN, Universal Calling Converter, which has the capability to interface up two local telephone sets or PAX lines. It can be programmed as Long Line Extension Exchange or Telephone side, Local Battery or Central Battery.

INTE card, which can be equipped in alternative to a LFS card, is basically used for LF back to back connection between two PLC or others different analogue carriers. The LF useful band is available on 4 wire input / output. Being the unit designed for double channels, only one card is usually equipped and housed independently on one of the LF slots.

1.2 HF Signal elaboration

One single card, the MODAF, high frequency modem, makes all the operation of this section.

The HF section can work, according to the requirements, either in single or double channel configuration.

On the transmission side, MODAF card, by DSP, modulates the signal received from LFS card and convert from digital to analogue.

Through the hybrid circuit the MODAF can interface one or two 20 W amplifiers in order to get up to 40 W on HF line.

On the receiver side, the signal coming from the RX filter is kept constant by the AGC, controlled by the digital demodulator present in the MODAF card.

MODAF card display, by LED's on the front panels, TX and RX alarms and manage relays contacts dedicated to remote indications.

1.3 HF Power section

This section is based on :

AMPL	Power Amplifier
INTX	Transmission Interface
INRX	Reception Interface

PLC 1790/B REVISION2 can be equipped with up to two 20 W amplifiers. When only one amplifier is equipped, the second MODAF output is internally loaded and the sum of the signals in the INTX card is bypassed.

In case that the PLC output is of 40 W, the second amplifier is equipped, driven by the second MODAF output, and on the INTX board the sum is done.

The HF power signals reach the transmission filter. This filter is programmable by soldering straps for all the PLC useful band, 40 ÷ 500 kHz at one kHz step, either in single or double channel without changing any components.

Next, the signals will reach the HF hybrid, on the INRX board, and then the HF line.

On the reception way the signals incoming from the HF line meet the HF hybrid. The reception branch of the hybrid is connected to the RX attenuator, which must be programmed according to the HF line attenuation, and then to the RX filter.

The filter is programmable by soldering straps for the entire PLC useful band, 40 ÷ 500 kHz at one kHz step. The output of the RX filter goes straight to the MODAF input.

1.4 Supervision interface

This card is an optional of the equipment. By means the INSU card, the operator has the capability from one end of the link to test completely and program LF section the remote equipment and enable the remote PLC to activate the HF equalization function. A PC with the appropriate software manages the unit.

1.5 PC interface

Basically every card equipped with the DSP has its own programming interface.

All those interface are connected to a common field connector. The unit interrogation is made in polling mode.

2. EQUIPMENT ARCHITECTURE

The equipment includes a 9-unit subrack; 3 units are dedicated to the field connectors and 6 to the electronic cards.

Reference can be made to figure 2 that depict the PLC 1790/B REVISION2 subrack layout.

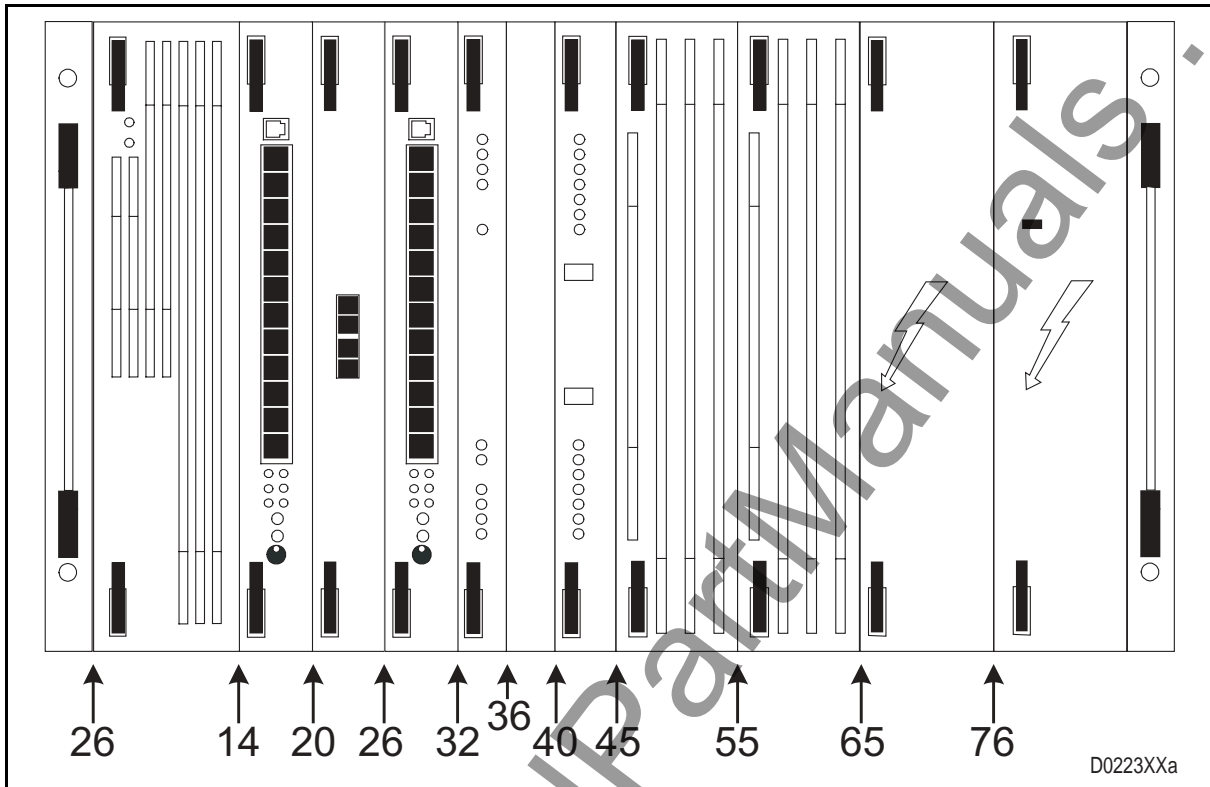

In the following, table 1 lists the various units, and their maximum quantity that can be equipped in a PLC 1790 terminal.

Position	Code	Description	Acronym	Max. Qty
2	478.410.000	Power Supply Unit	ALIM	1
14-26	411.410.034	Low Frequency Section	LFS	2
14-26	411.410.035	Low Frequency Section	LFS 3	2
14-26	411.412.011	Transit Interface	INTE	1
20	474.415.026	Universal Call Converter	CCUN	1
32	411.410.027	Programmable. Supervision. Interface	INSU	1
36	299.704.331	Cover Plate		1
40	411.410.039	High Frequency Modem	MODAF	1
45-55	474.412.008	20W Amplifier	AMPL	2
65	474.412.009	TX Line Interface	INTX	1
76	474.412.010	RX Line Interface	INRX	1

TABLE 1 – PLC 1790/B REVISION2 SUBRACK COMPOSITION

All units feature 32 or 64 pin polarised Eurocard connectors that plug into the subrack motherboard that provides all the interconnections.

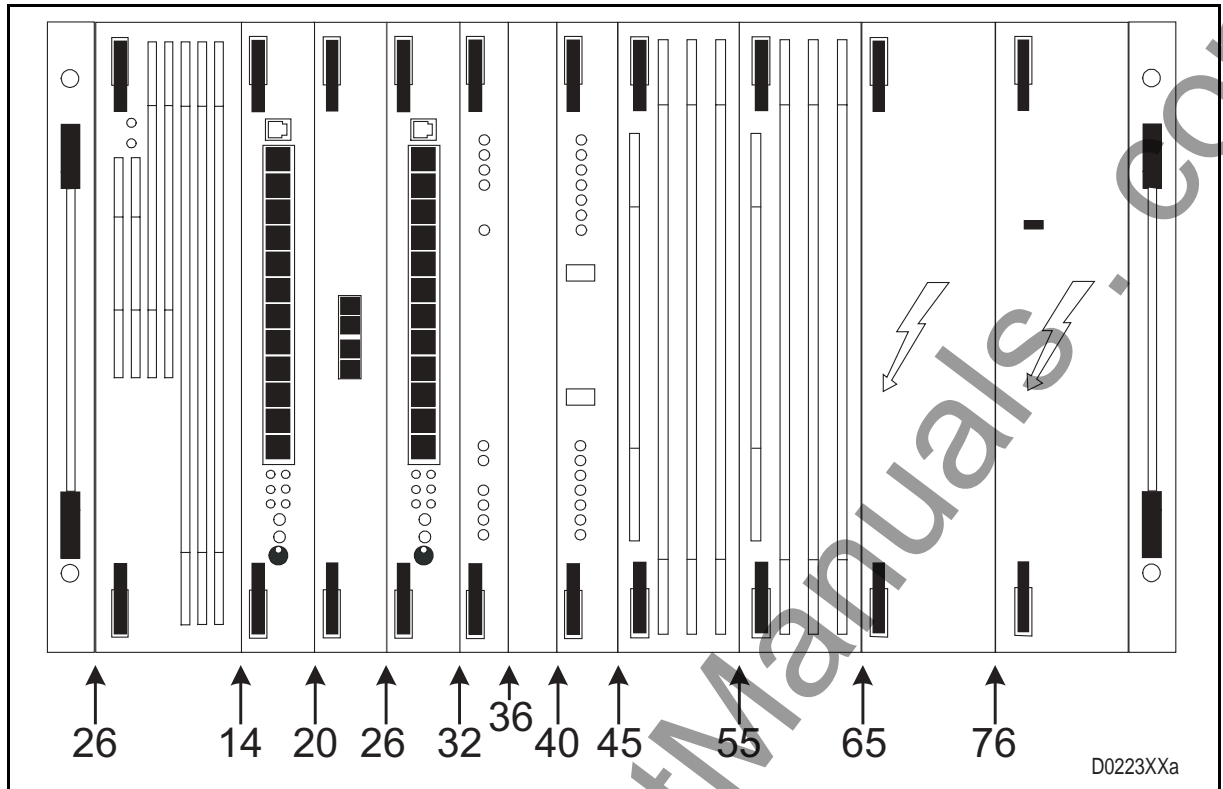

FIGURE 2 – PLC 1790/B REVISION2 SUBRACK - UNITS COMPOSITION

www.ElectricalPartManuals.com

3. FUNCTIONS AND INTERFACES DESCRIPTION

PLC terminals, such as PLC 1790/B revision2, allows the building of communication systems characterized by long distance links where data transmission security is a mandatory requirement.

The PLC1790/B revision2 terminal performs simultaneously the transmission of speech, telephone call, telegraph channels, which support data transmission for remote operations of SCADA systems.

3.1 PLC 1790/B Revision2 interconnection facilities

In the following, with reference to table 2 – Field connectors and figure 3, a description is given of the connectors provided on the “ Field Interconnection Panel ” to support the wiring between a PLC 1790/B REVISION2 terminal and input output user services.

CONNECTOR	SUPPORTED CONNECTION
M1	48 Vdc power supply input
M2	I/O for speech, signaling, HF, L2 of channel 0
M3	I/O for speech, signaling, HF, L2 of channel 1
M4	MTU data interface channel 0
M5	MTU data interface channel 1
M6	Interface for programming terminal
M7	I/O signals for supervisory functions
M8	Alarms connector (by relay)
M10	I/O Telegraph Channels 0
M32	I/O Telegraph Channels 1
M13 to M18	Subrack alarms output
M37	Open Collectors alarms
M38	HF 2 wires TX / RX interface

TABLE 2 – FIELD CONNECTORS

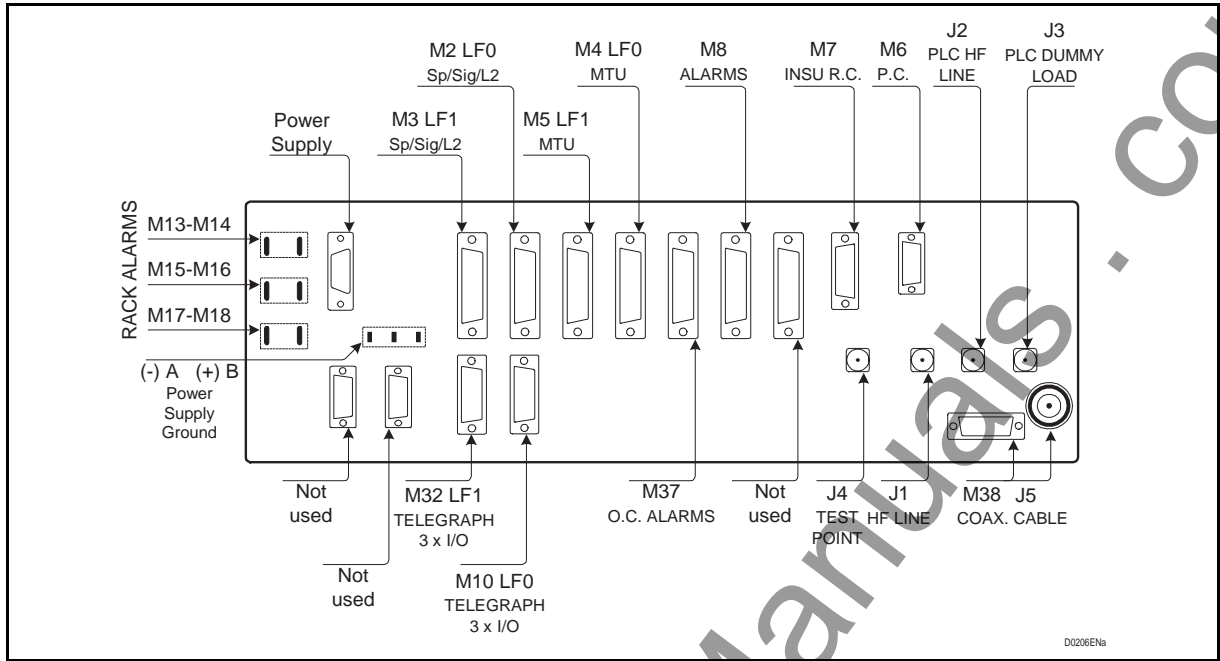

FIGURE 3 – FIELD INTERCONNECTION PANEL

www.ElectricalPartManuals.com

4. MODULE DESCRIPTION

4.1 Power Supply Unit (ALIM) 478.410.000

4.1.1 Introduction

The Power Supply Unit includes a switching converter which performs according to the following characteristics :

Input voltage 48 Vdc (-15% +20%) (40.8 ÷ 57.6 Vdc)

Output +5 Vdc +/-5%, Iout = 2.5A

Output -5 Vdc +/-5%, Iout = 0.4A

Output +15 Vdc +/-5%, Iout = 0.8A

Output -15 Vdc +/-5%. Iout = 0.8A

Output -36 Vdc (-5% + 10%) Iout = 2.5A (8.4A peak with duty cycle 1%, Ton = 1sec)

4.1.2 Description

figure 4 describes the functional blocks of the power supply unit. These are :

1. **Limiter** To limit the peak current.
2. **Battery filter** To reduce the noise on the input voltage due to the switching converter.
3. **Alarms & Commands** To provide for main quartz oscillator, synchronism commands, feedback's of each output voltage, over-voltage alarm and output current limitation.
4. **Power stage** Mainly composed of static switches (mosfet), which perform as current amplifiers and as transformers to obtain the required output voltages.
5. **Rectifiers & Filters** The signals coming from the power section are square waves so they must be rectified and filtered to become continuous and with low ripple values.

The power supply unit provides front and side heat skin.

4.1.3 Power Supply block diagram

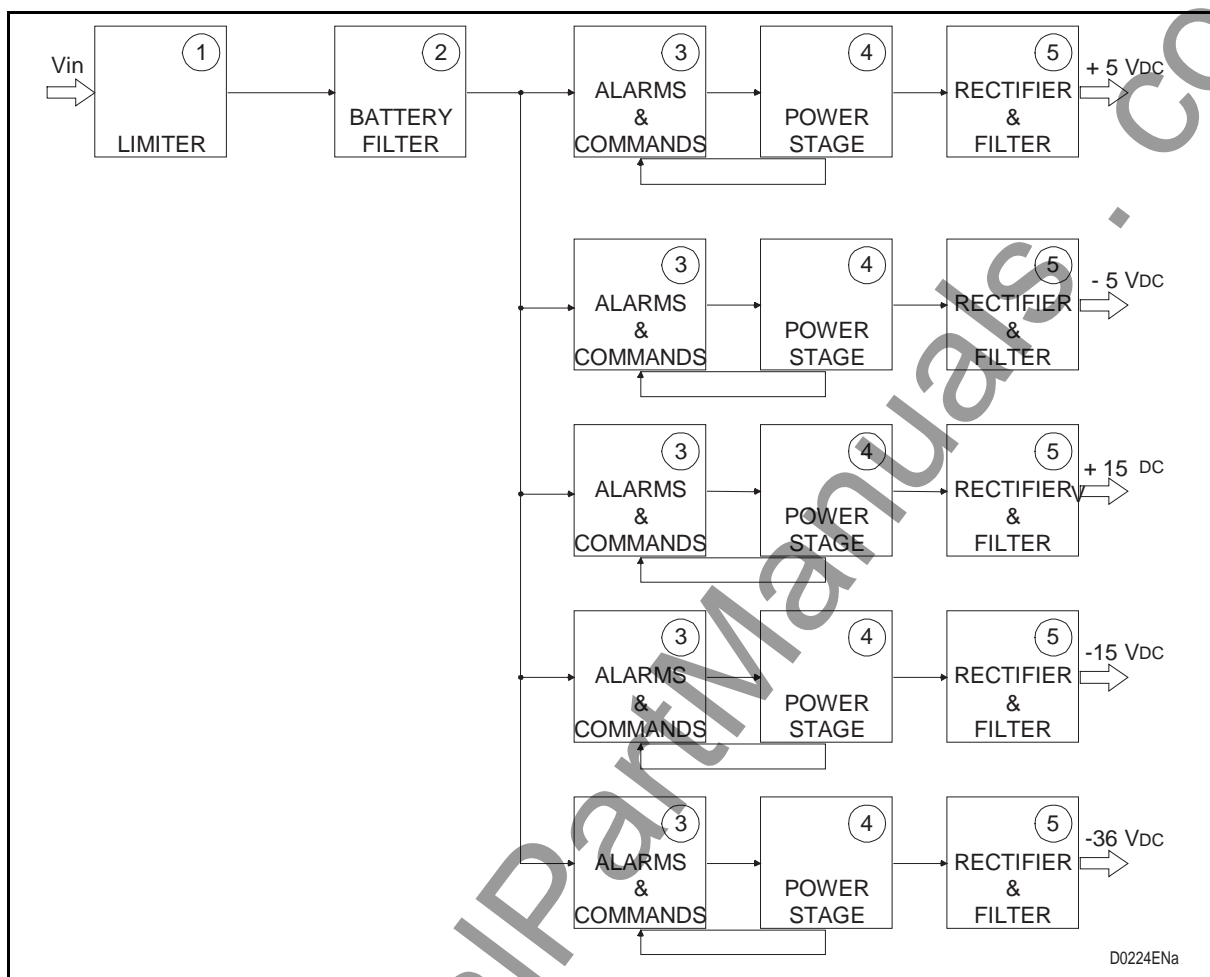

FIGURE 4 – POWER SUPPLY UNIT BLOCK DIAGRAM

4.2 Low frequency section (LFS) 411.310.034

4.2.1 Introduction

The following description makes reference to figure 7.

We can individuate the following functional blocks:

- [1] Speech Channel
- [2] Service Telephone Set
- [3] Telegraph Service
- [4] MTU built-in Modem
- [5] Signaling
- [6] LINE 2 Interface
- [7] Party Line
- [8] HF Interface
- [9] Daughter card (Only on LFS3)

For the unit programming and test refer to vomule 4 "COMMISSIONING"

Difference between LFS and LFS3 can be summarized in:

Service	LFS	LFS3
Telegraph	2 I/O	3 I/O
MTU	Up to 600 bps FSK on superimposed band 1200 bps FSK on all the whole band	Up to 600 bps FSK on superimposed band 1200 bps FSK on all the whole band 1200 bps QPSK on superimposed band.

4.2.2 Description

4.2.2.1 Speech Channel [1]

The functions performed by this block are:

Transmission side

2/4 wires speech changeover, controlled by external signal

Nominal level adjustment by means of a variable attenuator driven by PC.

Analogue/Digital conversion (A/D)

Dynamic compression

Limiter

Speech gain facility (+6 dB) to increase peak envelop power when only speech service used.

Speech channel filter

Reception side

Speech attenuation facility (-6 dB) in order to provide the same generated signal level to the reception path.

Speech channel filter

Dynamic expansion

Digital/Analog conversion (D/A)

Nominal level adjustment by means of a variable attenuator driven by PC

2/4 wires speech interface programmable by external control

4.2.2.2 Telephone Service [2]

Allow the communication between the two PLC terminals. The operator can call, by a push-button, the remote station where the incoming call is returned by a buzzer. The telephone set microphone is activated by a push-to-talk button

4.2.2.3 Telegraph Service [3]

This block performs the following both transmission and reception functions:

Field electrical interface by a transformer

Level Adjustment by programmable attenuator driven by programming terminal

A/D (transmission) and D/A (reception) conversions

Telegraph channel filter

The LFS card can manage up to 2 input/output telegraph channels interfaces.

Installing the daughter board the I/O managed are up to three.

4.2.2.4 MTU built in Modem [4]

The data modem performs the modulation/demodulation of serial data present on a standard interface RS232.

According to the modulation scheme, the available operating rates are:

FSK modem (Frequency Shift Keying) 50-100-200-600-1200 bit/sec (the whole 4 kHz band is used when the rate of 1200 bit/sec is used) on asynchronous mode.

Adding the daughter board the MTU 1200 bps QPSK modulation, asynchronous or synchronous mode, on superimposed band.

4.2.2.5 Signaling [5]

The signaling channel allows the reception/transmission of E/M calling criteria (busy and dialing).

This block performs the following functions:

Transmission side

Field electrical interface of the input call wire - M

FSK or ON/OFF modulation

Generation of the signaling frequency

Reception side

Filtering of the signaling band

FSK or ON/OFF demodulation

Field electrical interface of the outward call - E - ground reference

4.2.2.6 Line-2 interface [6]

This interface provides for the electrical connection with a 4-wire transmission media and meets the interface requirements of an external Teleprotection. The following functions, shown in figure 7, are performed :

Transmission side

Field electrical interface by a balanced transformer

Level regulation through a variable attenuator driven by programming terminal

Interface for external Teleprotection

Cable equalizer which can be activated by programming terminal

A/D conversion

Channel filter

Reception side

D/A conversion

Channel filter

Interface for external Teleprotection

Filed electrical interface

4.2.2.7 Party line [7]

The party line block performs the following functions:

Transit of the whole band through the LF interface

Add / Drop of the telegraph channel from / to the LF interface

Add / Drop of the data channel from / to the LF interface

Party line of telegraph channel and/or data channel

Add / Drop of the speech channel from / to the LF interface

Party line of speech channel and ON/OFF signaling.

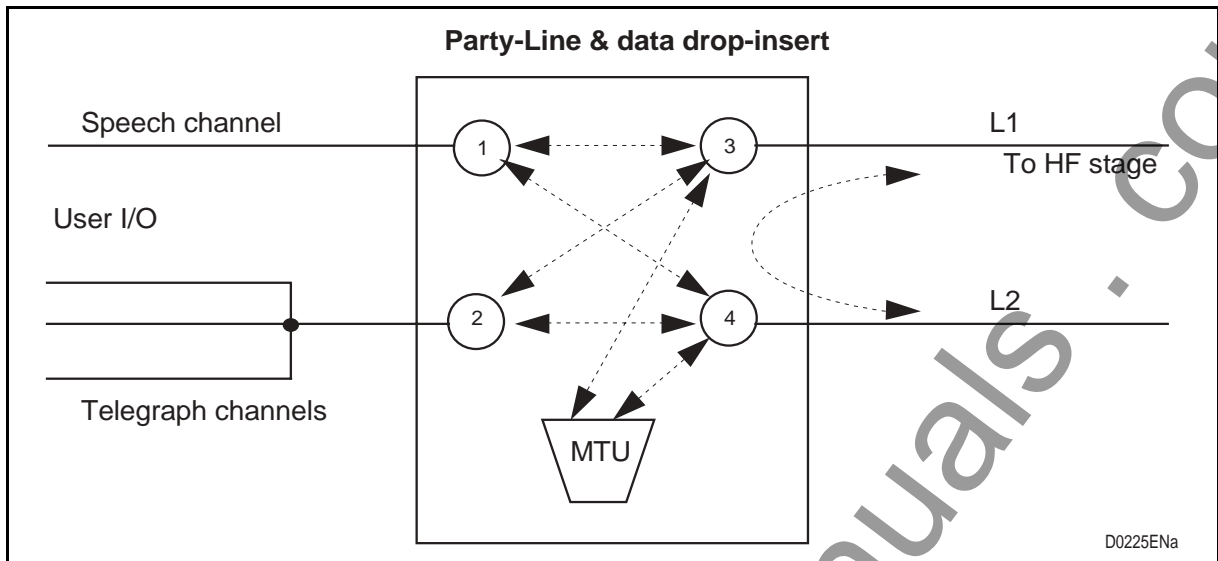

FIGURE 5 – PARTY-LINE FUNCTIONS

The party line service provided by LFS card allows all crossing exchanges displayed by the above scheme.

The crossing selection by means of MMI can be applied with the following modes:

- I/O and MTU to/from L1 and/or L2
- L1 to/from L2 only
- L1 to/from L2 and MTU and I/O

The party line, as shown in figure 5, may be used also if two LFS boards are plugged on the same 0 ÷ 4 kHz transmission channel.

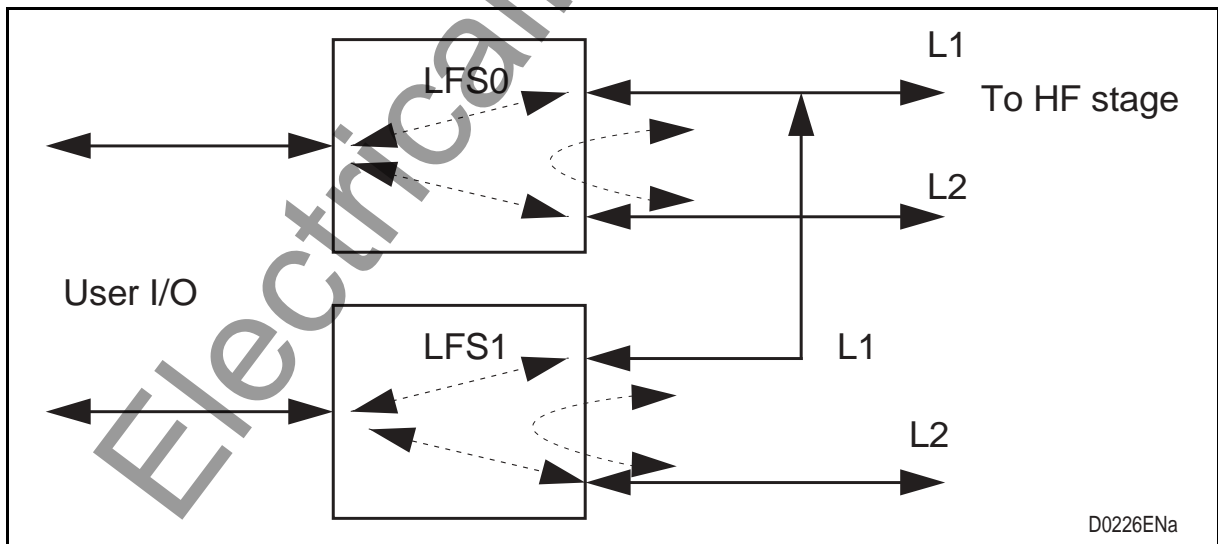

FIGURE 6 – COMMUNICATION CHANNEL WITH TWO LFS CARD

4.2.2.8 HF Section interface [8]

This interface provides for the digital connection between low frequency and high frequency sections and an analogue interface that can be used as an extended I/O telegraph channel interface.

4.2.2.9 Daughter board

This card can be added to implement up to 3 I/O telegraph channels and/or a 1200 bps data channel, which can be programmed, in the presence of speech channel, on the superimposed frequency band. The modulation scheme of the over-voice modem is 4PSK in order to reduce the need useful band at 1200 Hz which can be programmed in different part of the 4 kHz band.

4.2.3 LFS block diagram

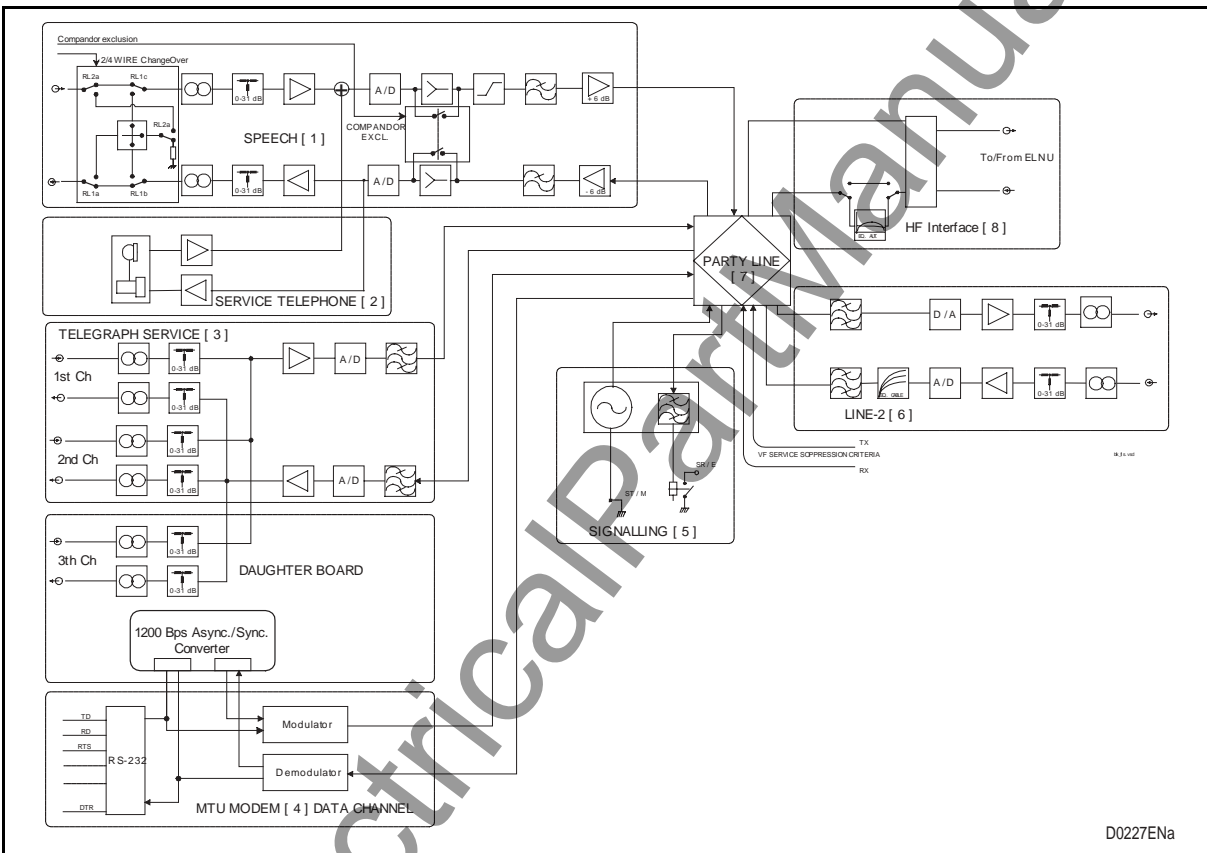

FIGURE 7 – LFS BLOCK DIAGRAM

4.3 Transit interface (INTE) 474.412.011

4.3.1 Introduction

This unit meets the digital input / output MODAF interfaces and the analogue user input / output interfaces.

The useful bandwidth is $300 \div 3720$ Hz, for each single channel, which operates on 4 wires balanced input / output . Level adjustments are possible by straps.

4.3.2 Description

We make reference to the block diagram on figure 8.

Two twin circuits are defined respectively for the Channel 0 and Channel 1.

The two independent circuits are enabled by the two signals SYNC-0 and SYNC-1.

The incoming signals from the field are converted by A/D codec. The internal filter of the codec on itself defines the useful bandwidth. The digital signal is sent to the ELNU card always in serial mode.

On the reception way, the digital signal coming from the ELNU is converted to analogue by D/A codec.

Input and output analogue levels can be adjusted by operating strap attenuators.

4.3.3 INTE Block diagram

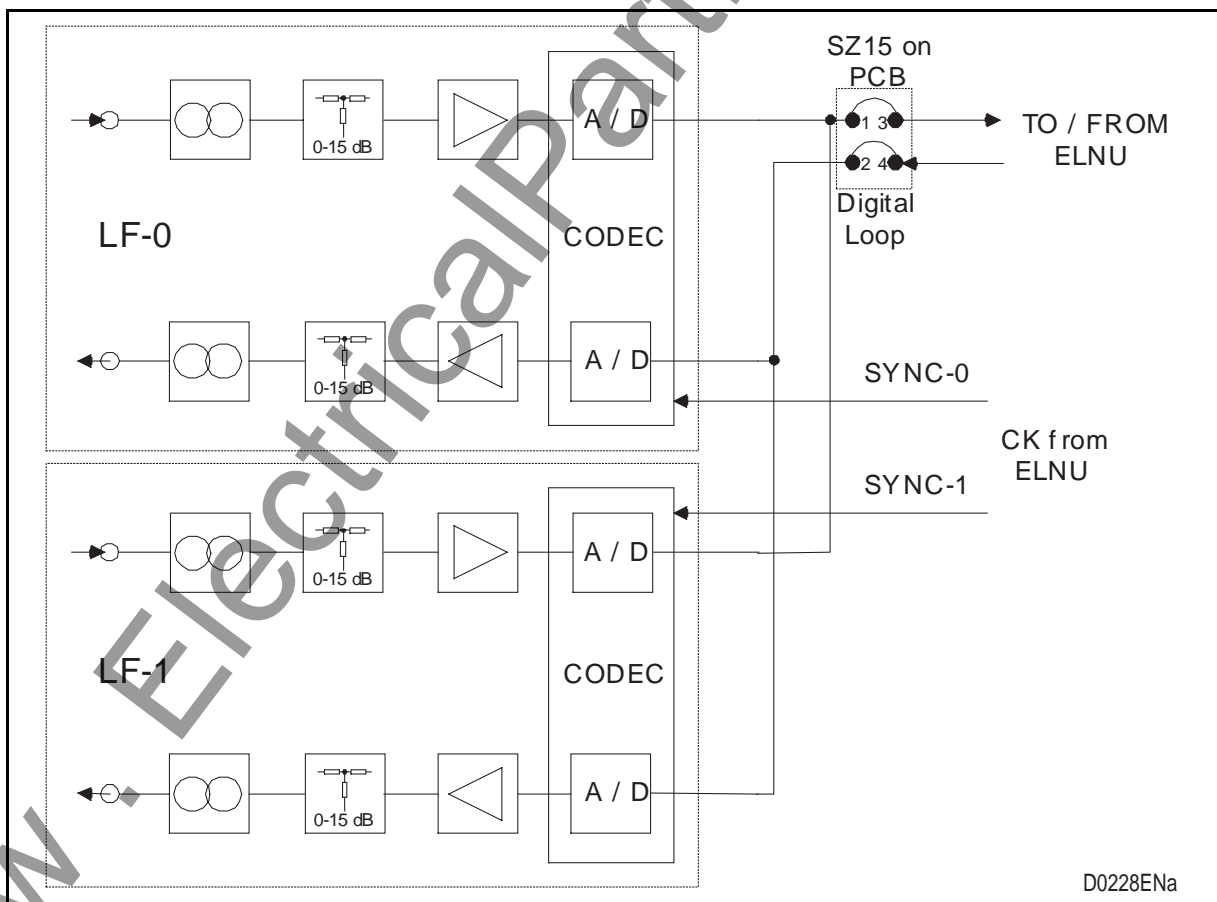

FIGURE 8 – INTE BLOCK DIAGRAM

D0228ENa

4.4 Universal Call Converter (CCUN) 474.415.026

4.4.1 Introduction

The following description makes reference to figure 9, figure 10 and figure 11.

Since CCUN card is designed to manage two independent circuits, so that it can interface both LFS's on a double channel PLC, the description is exactly the same for both circuits. The "x" figure in the reference takes the value 1 for circuit 1 and value 2 for circuit 2.

In transmission, the unit performs the conversion of call criteria (hook-off and dialing) into commands, which activate the signaling circuit. In reception, complementary operations are carried out. In addition the ring voltage (50 Vrms/45 Hz) for telephone ringing is provided.

4.4.2 Description

CCUN board supports the operation of two telephone channels and it can be programmed to operate as follows :

- central battery (BC)
- local battery (BL)
- long line extension, telephone side (PLA-T)
- long line extension, exchange side (PLA-C)

Section points are available on the CCUN front panel; their purpose is to disconnect the PLC equipment from the telephone and from the signaling.

The unit includes the following functional blocks:

MANAGEMENT LOGIC

According to the selected configuration, through the strips SZ4 and SZ8, the Management Logic handles criteria towards both exchange and telephone set.

RING CALL GENERATOR

This circuit is usually enabled only on PLA-T, BL and BC configurations. The call generator supplies the call voltage ~ 50 Vrms / 45 Hz for the telephone bell.

RING CALL DETECTOR

The circuit detects the alternate current that activates the telephone bell. When the user hangs up the handset the signals IMAC1* and IMAC2* are issued and the management logic disables the ring generator.

RX CALL DETECTOR

The circuits are used in BL and PLA-C configurations (SZ10 - SZ11) to detect the call voltage, coming from a BL telephone or a telephone exchange.

4.4.2.1 BC PRE-SETS

Refer to figure 9.

Idle conditions

Ground absence at CCUx- 4W (E criteria)

Ground absence at CCUx-3W (M criteria)

Speech channel, LF side, closed on 600 ohm (a & b wires)

Operating conditions

Transmission call

IMPx* signal is generated when the hand set is hanged up and the following occurs:

Transmission call issuing, ground criteria at pin CCUx-3W, for a time of about 4 seconds

RL2 switched to 9-13 position, thus enabling the telephone connection to PLC

Disabling of undesired potential reception calls by means of CA.EN signal which switch off the ringing generator.

The call criteria runs only 4 seconds. If within this time frame, the other operator does not answer, the caller can repeat the operation.

RECEPTION CALL

The reception call, pin CCUx-4W, is activated by a ground criteria for about 4 seconds. The following events occur:

A potential transmission call, if any , is blocked (No ground on pin CCUx-3W).

RL1 switched to 4-8 and 9-13 positions, thus enabling the transit of 50 Vrms/45 Hz call voltage to the telephone.

The ringing generator (CA.EN signal) is enabled.

Two different operating conditions must be considered as to the situation existing when the called operator hangs up the handset :

HOOK-OFF THE HANDSET WHILE THE CALL IS STILL IN PROGRESS

In this case the following occurs:

IMACx* signal is generated thus stopping the ringing generator, in addition RL1 is switched to positions 4-6 and 11-13.

IMPx* signals are generated and RL2 is switched to position 9-13.

In this condition the communication can start.

HOOK-OFF THE HANDSET WHEN THE RINGING TONE IS NOT PRESENT.

In this case the following occurs:

IMPx* are generated thus blocking the ring generator, RL1 is switched to positions 4-6 and 11-13 and RL2 to position 9-13.

In this condition the communication can start.

4.4.2.2 BL PRE-SETS

Refer to figure 10.

Idle conditions

absence of ground at CCUx-4W

absence of ground at CCUx-3W

speech channel enabled towards LF terminal

Operating conditions

TRANSMISSION CALL

As the 50 Vrms ringing voltage, triggered by a BL telephone, is detected then the signal RIVACx* is generated and the following occurs:

TX call is issued at CCUx-3W (ground presence)

RL2 is switched to position 11-13 thus closing the speech channel on 600 ohm.

These conditions last for the whole period associated with the ringing voltage generation.

The calling operator hooks off the handset and waits for the answer of the called operator.

RECEPTION CALL

As a reception call CCUx-4W is in progress, the following events occur :

RL1 is switched to positions 4-8 and 9-13.

The RING CALL GENERATOR is enabled by means of CA.EN outgoing signal.

In this condition the communication can be initiated.

In order to not be disturbed by the ringing tone, the called operator should hook off the handset right after the ringing sound is off.

4.4.2.3 PLA-T PRE-SETS

Refer to figure 11.

Idle conditions

telephone side open (handset is hook on)

speech channel, LF side, closed on 600 ohm

absence of ground at CCUx-3W

absence of ground at CCUx-4W

Operating conditions

TRANSMISSION CALL (PLA-T ⇒ PLA-C)

As the operator hooks off the handset, IMPx* signals are generated and the following occurs:

RL2 switches to position 9-13, with a delay of 150 msec.

The ringing generator is locked through CA.EN criteria

Ground criteria on pin CCUx-3W

The operator can start to dial.

The dialing action is reflected by the absence of ground at pin CCUx-3W.

At the same time, relay RL2 switches to position 11-13, as the dialing is ended, RL2 switches to position 9-13.

RECEPTION CALL (PLA-C \Rightarrow PLA-T)

Ground presence at pin CCUx-4W causes the following events occur:

Relay RL1 switched to 4-8 and 9-13 positions

50 Vrms ringing generator is enabled

The same considerations discussed under previous paragraph "BC PRE-SETS" apply as to the different operating conditions existing when the called operator could hook off the handset.

4.4.2.4 PLA-C PRE-SETS

Refer to figure 11.

Idle conditions

absence of ground at pin CCUx- 3W

absence of ground at pin CCUx-4W

speech channel, LF side, closed on 600 ohm

Operating conditions:

Transmission call (PLA-C \Rightarrow PLA-T)

The 50 Vrms ringing voltage, coming from the is detected by the "RING CALL DETECTOR" which in turn, through the generation of RIVACx* issues the CCUx-3W criteria.

Reception call (PLA-T \Rightarrow PLA-C)

The seizing made by the PLA-C is recognized as a ground criteria at pin CCUx-4W.

The result is:

block of potential transmission calls

RL2 is switched to position 9-13 thus enabling the transit of the exchange tone to PLA-T operator.

The PLA-T operator can dial the telephone number thus creating presence or absence of ground at pin CCUx-3W. The result of this action is:

RL2 is switched to position 11-13 during the dialing process. A 150 msec time-out is initiated to keep the relay closed. During this phase RL1 is in idle condition.

As the dialing is accomplished, RL2 returns to position 9-13 and the communication may take place.

4.4.3 CCUN Block diagrams

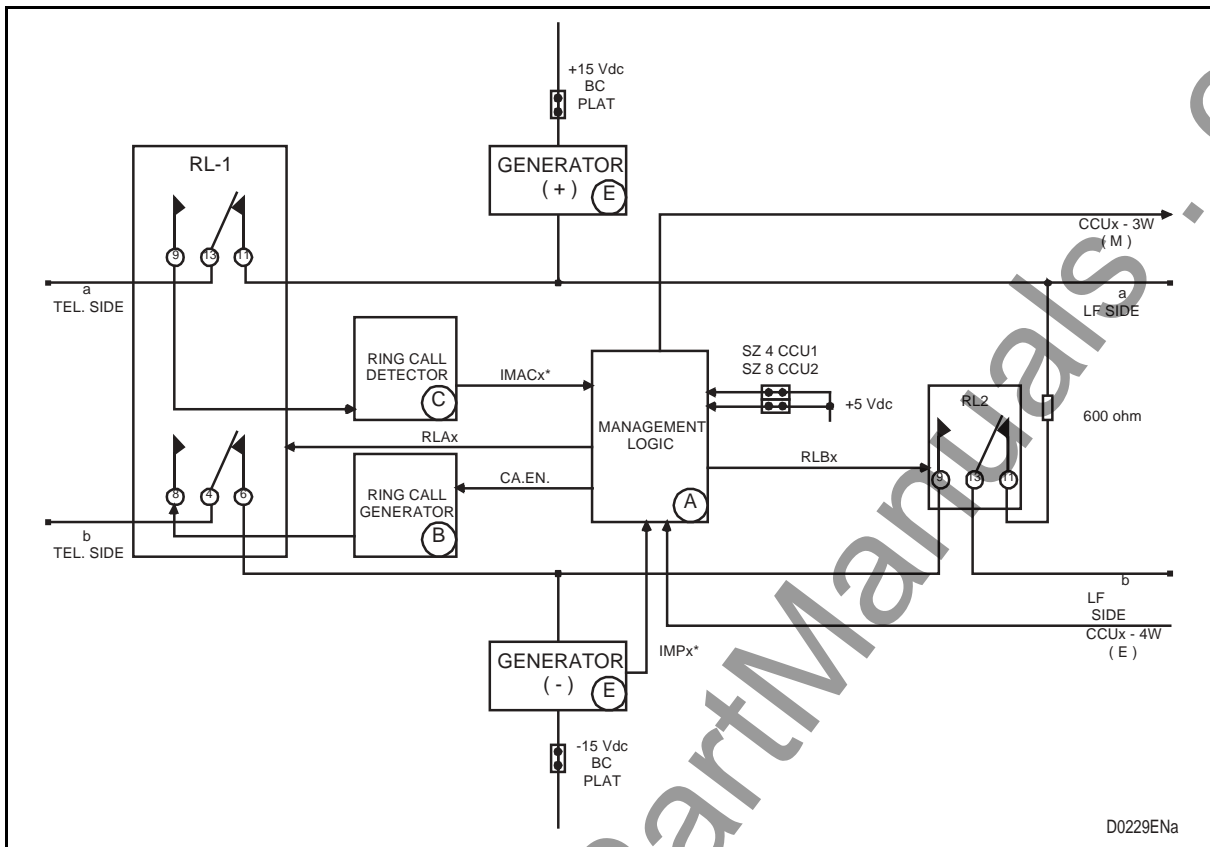

FIGURE 9 – BC/PLA-T CONFIGURATION

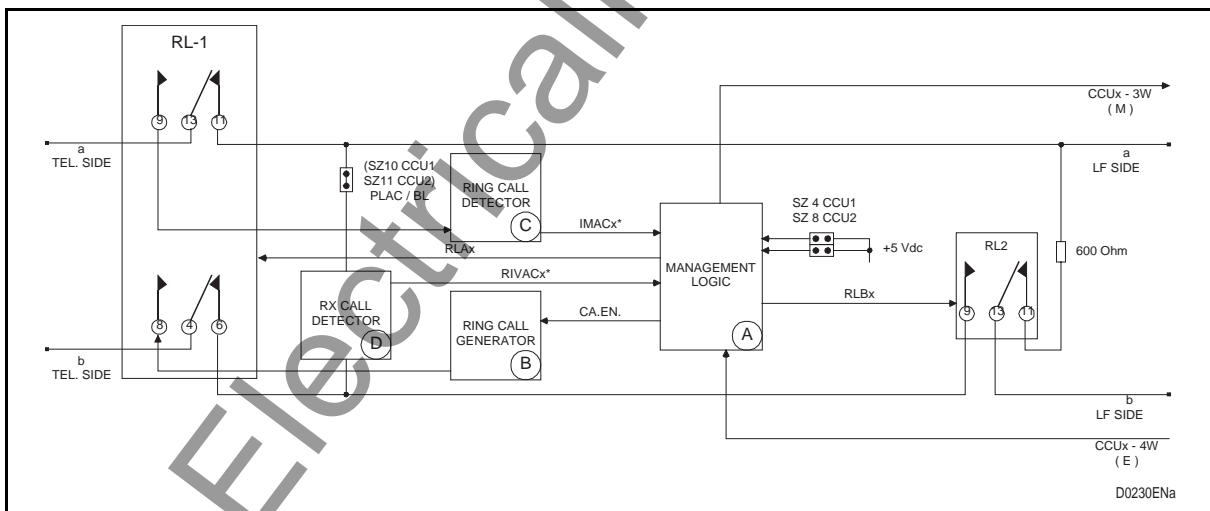

FIGURE 10 – BL CONFIGURATION

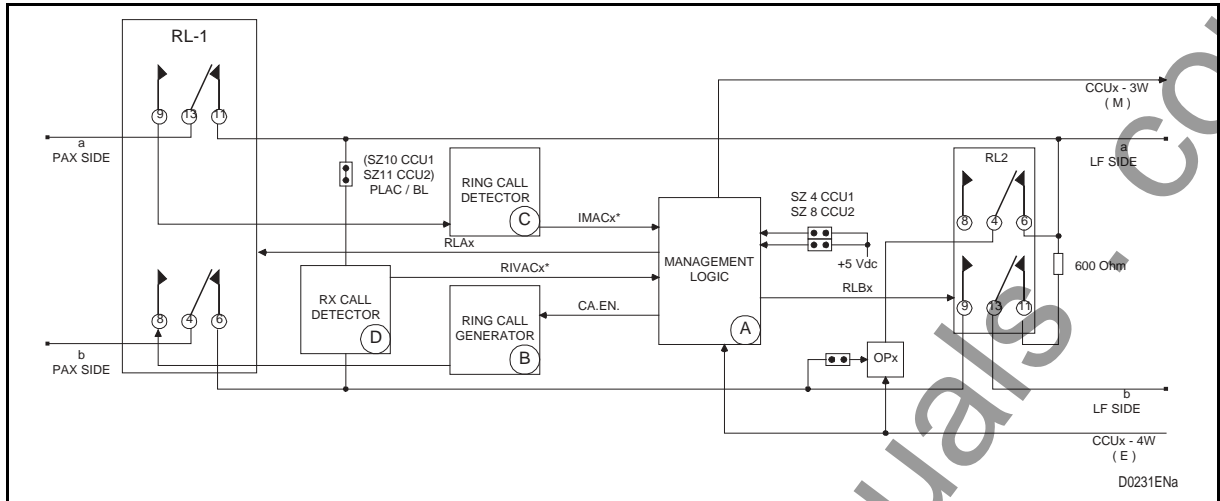

FIGURE 11 – PLA-C CCUN CONFIGURATION

www.ElectricalPartManuals.com

4.5 High frequency modem (MODAF) 411.410.039

4.5.1 Introduction

It is the main unit of the PLC 1790/B REVISION2 equipment. It manages the master clock of the equipment, performs the digital modulation and demodulation, and supervises the main function of the digital circuits.

For the description we make reference to the figure 12.

4.5.2 Description

The following functions are performed:

Synchronism generation and carrier digital synthesis of HF channels.

These functions are supported by:

- Main oscillator, which generates the master clock
- Centralized logic to provide for the machine timings
- Generation of HF mo-demodulation carriers.

Transmission side

Synchronism and exchange of data coming from SERVICES (LF channels 1 / 2 and INSU)

Modulation of SERVICES

Sum of SERVICES and carriers

Transmission level adjustment

Sampling frequency increase from 32 to 2048 kHz

HF band allocation

Conversion from digital to analogue and HF output to HF Power Amplifier

The MODAF card is programmed via a PC, setting the number of channels, carrier frequencies, transmission alarm definition, by means of a MMI menu.

A squelch detects on the transmission path the overload of the global services coming from the low frequency section in order to protect the transmission power section. An alarm is provided if the protection threshold is overcome.

Reception side

The first stage is represented by a 7 dB attenuator which can be included to reduce the reception overload

Analogue to Digital conversion of the HF signal coming from INRX

Demodulation of digital signal

Digital synchronization of the RX carrier by means Digital PLL.

Reduction of the sampling frequency from 1024 to 16 kHz

Demodulation and carrier drop for automatic level control (AGC)

SERVICE demodulation:

Synchronism and exchange of serial data to be sent to channel 1 (LFS 0)

Synchronism and exchange of serial data to be sent to channel 2 (LFS 1 for double channel PLC terminals).

Synchronism and exchange of serial data to be sent to INSU

Digital recovery of TPS if output 12-16 kHz

4.5.3 Common part

- FPGA firmware upgrade using dedicated Xilinx tools
- DSP firmware upgrade using dedicated Motorola tools
- Equipment Alarms Criteria management
- MMI interface for site data programming and saving on Eeprom.
- General WD to supervise all the unit functions

4.5.4 MODAF Block diagram

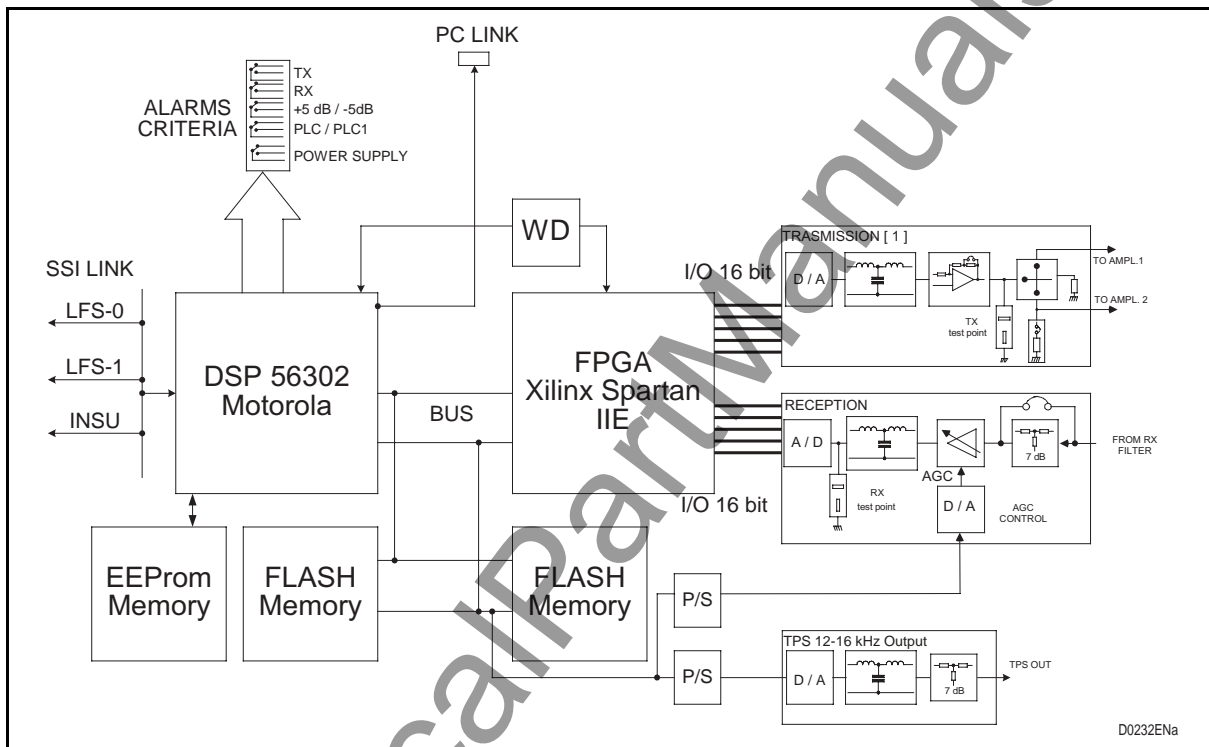

FIGURE 12 – MODAF BLOCK DIAGRAM

www.ElectricalPartManuals.com

4.6 20W Amplifier (AMPL) 474.412.008

4.6.1 Introduction

Refer to figure 13.

It amplifies the transmission signals, within the operating frequency range from 40 to 500 kHz, up to an output power of 20 Watt.

The unit is provided with a heat dissipater on both front and side panel.

The following major functional sections are described :

- Differential amplifier
- Driver stage
- Power stage
- Adder transformer and impedance adapter
- Polarizer and thermal protection
- Protection for power stages

4.6.2 Description

4.6.2.1 Differential amplifier

The main function of this section is to generate two amplified signals of the same amplitude and opposite phase.

4.6.2.2 Driver stage

The main function is to provide for current amplification decoupling the differential stage from the power stage.

4.6.2.3 Power stage

The main function of this block is to deliver the target output power.

4.6.2.4 Adder transformer and impedance adapter

The main function of this section is to add the output of the power stages and to adapt their impedance.

4.6.2.5 Polarizer and thermal protection

The main function of this section is to polarize the final stages to optimize the distortion.

The polarization is dynamic and varies according to the final stages temperature.

4.6.2.6 Protection for power stages

These blocks act as protections for power stages.

4.6.3 Amplifier Block diagram

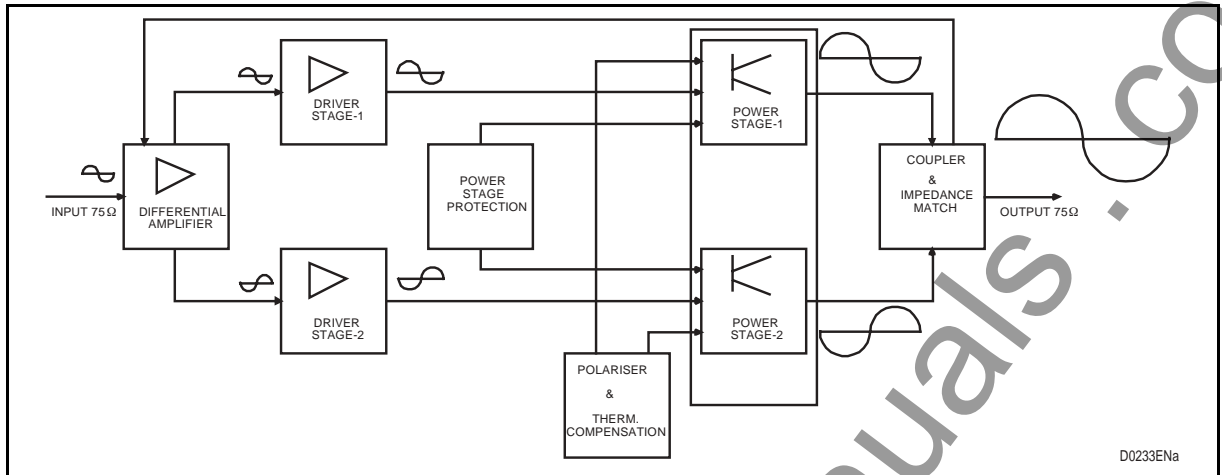

FIGURE 13 – 20 W AMPLIFIER

www.ElectricalPartManuals.com

4.7 Transmission Line interface (INTX) 474.412.009

4.7.1 Introduction

Reference can be made to chapter 1790B/EN CM ("COMMISSIONING"), for details relevant to programmable options selection procedures.

Refer to figure 14.

This unit performs the following functions:

- Adding the signals which come from two amplifiers
- Programmable transmission line filter

4.7.2 DESCRIPTION

4.7.2.1 Adding signals

An hybrid transformer is used for 40 Watt terminals.

It adds the signals received by the two 20 W equipped amplifiers.

4.7.2.2 Programmable tx line filter

The transmission filter is programmable by straps in the band 40 - 496 kHz by steps of 1 kHz

It attenuates the spurious produced by the terminal and supplies a high out-of-band impedance, thus providing for the parallel connection of several terminals on the same line.

4.7.3 INTX Block diagram

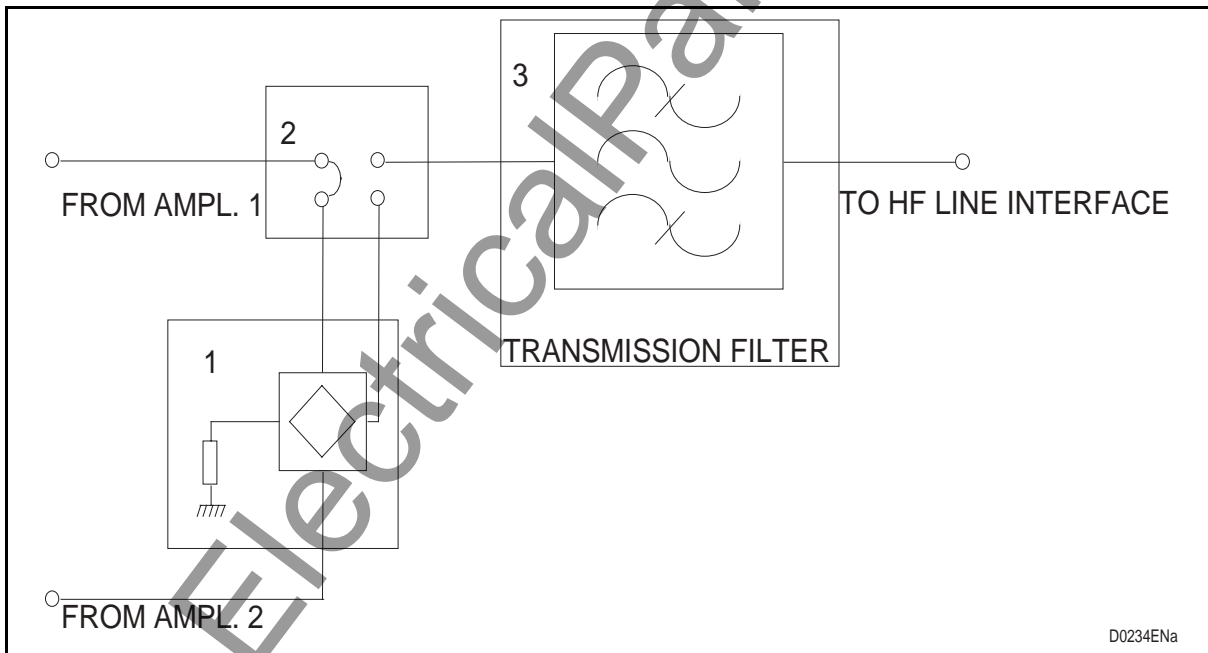

FIGURE 14 – INTX BLOCK DIAGRAM

4.8 Reception interface (INRX) 474.412.010

4.8.1 Introduction

Refer to figure 15.

The following features are supported:

- line hybrid
- power detector
- line transformer
- line complementary attenuation
- programmable RX line filter

4.8.2 Description

4.8.2.1 Line hybrid

The line hybrid is asymmetric in order to privilege the transmission path that is characterised by low loss level (0.3 dB).

The reception path operates at high impedance with about 12 dB loss.

4.8.2.2 Power detector

It detects the issued power to the line.

This information is sent to the INAF card to be checked in order to perform the transmission alarm if the signal is less than a programmed threshold.

4.8.2.3 Line transformer

The line transformer adapts the PLC 1790 impedance to the line impedance.

The available options are:

- 150 Ohm, balanced
- 125 Ohm, balanced or unbalanced
- 50 Ohm unbalanced
- 75 Ohm, unbalanced

4.8.2.4 RX attenuator

It is based on a variable attenuator from 0 to 18 dB at steps of 3 dB.

Its main purpose is to set-up the operating reference point of the automatic gain control.

4.8.2.5 Programmable RX line filter

The reception line filter can be programmed by straps in the 40 ÷ 496 kHz band at 1 kHz step

It selects the useful band from the interfering ones, thus avoiding the receiver overload.

4.8.3 INRX Block diagram

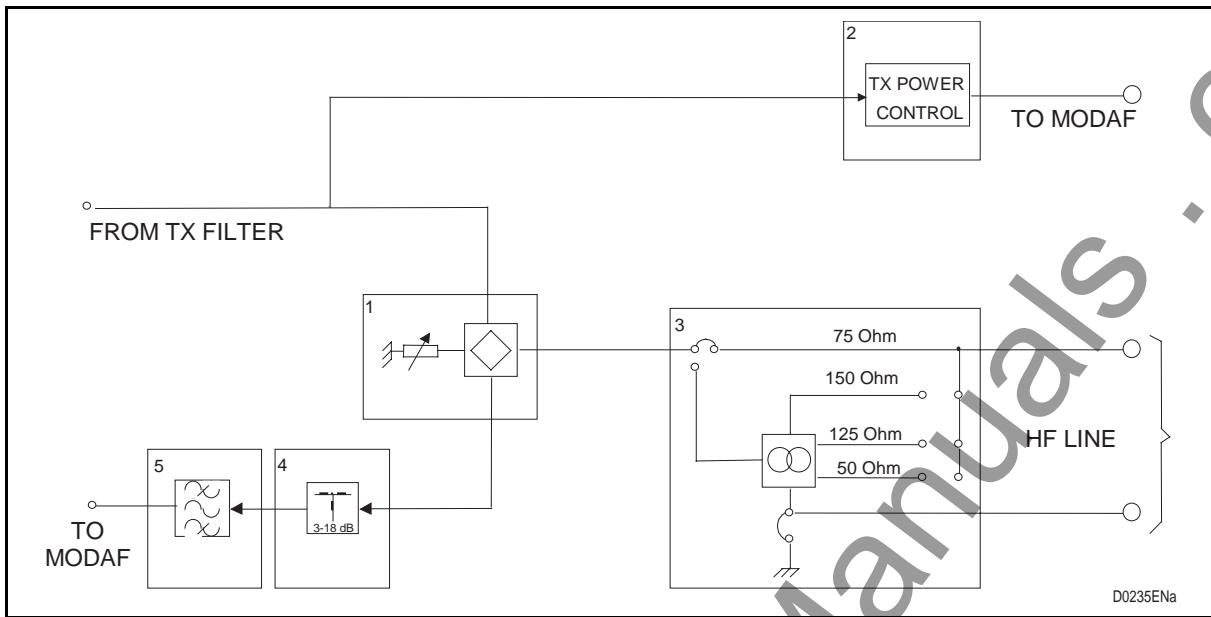

FIGURE 15 – INRX BOARD

www.ElectricalPartManuals.com

4.9 Programmable supervision Interface (INSU) 411.410.027

4.9.1 Introduction

The INSU Supervision card, through a programming terminal, allows the operator to monitor and control the remote PLC without any other operator at the far end (refer to figure 16).

4.9.2 Description

The INSU card is an optional unit of PLC 1790/B, to be equipped in one PLC link on both terminals, local and remote, in a dedicate slot of 19" - 9 Unit DIN PLC subrack.

It is based on 4 TX and RX criteria and 8 open collectors alarms foreseen for a future network management network.

The INSU unit perform the following services:

Transmission of N° 4 ON/OFF criteria to remote PLC terminal (by ground in input),

Reception of N° 4 ON/OFF criteria from remote PLC terminal (by relay changeover type for RC-1 and RC-2, simple contact open in idle condition for RC-3 and RC-4).

Open collector PLC alarms: (ground criteria in alarm condition)

Power supply alarm

Transmission alarm (3 dB Carrier level decreasing respect to the nominal level)

Reception alarm (5 dB Carrier level decreasing respect to the nominal level)

PLC alarm (OR of the following alarms: AGC reception alarm, loop alarm, S/N alarm)

Channel 0 audio frequency alarm (5 dB Signalling decreasing respect to the nominal level)

Channel 1 audio frequency alarm (5 dB Signalling decreasing respect to the nominal level)

Ch.0 and Ch.1 audio frequency alarm (S/N alarm)

Local loop and remote loop alarm (Activated during local and remote loop)

By programming terminal (PC) connected to local PLC equipment, it is possible to check and to perform the following functions on the remote PLC:

- monitor the AGC working point characteristics
- monitor the status of remote PLC alarms
- program the remote LFS function in both speech and data channels

Activation of HF line equalisation function on remote PLC in order to equalise the communication link.

The two INSU cards, plugged in both PLC terminals, communicate through a programmable low speed FSK MODEM 50 Bd programmed within 300 ÷ 3720 Hz frequency band. The required modem is housed in the INSU card.

4.9.3 INSU Block diagram

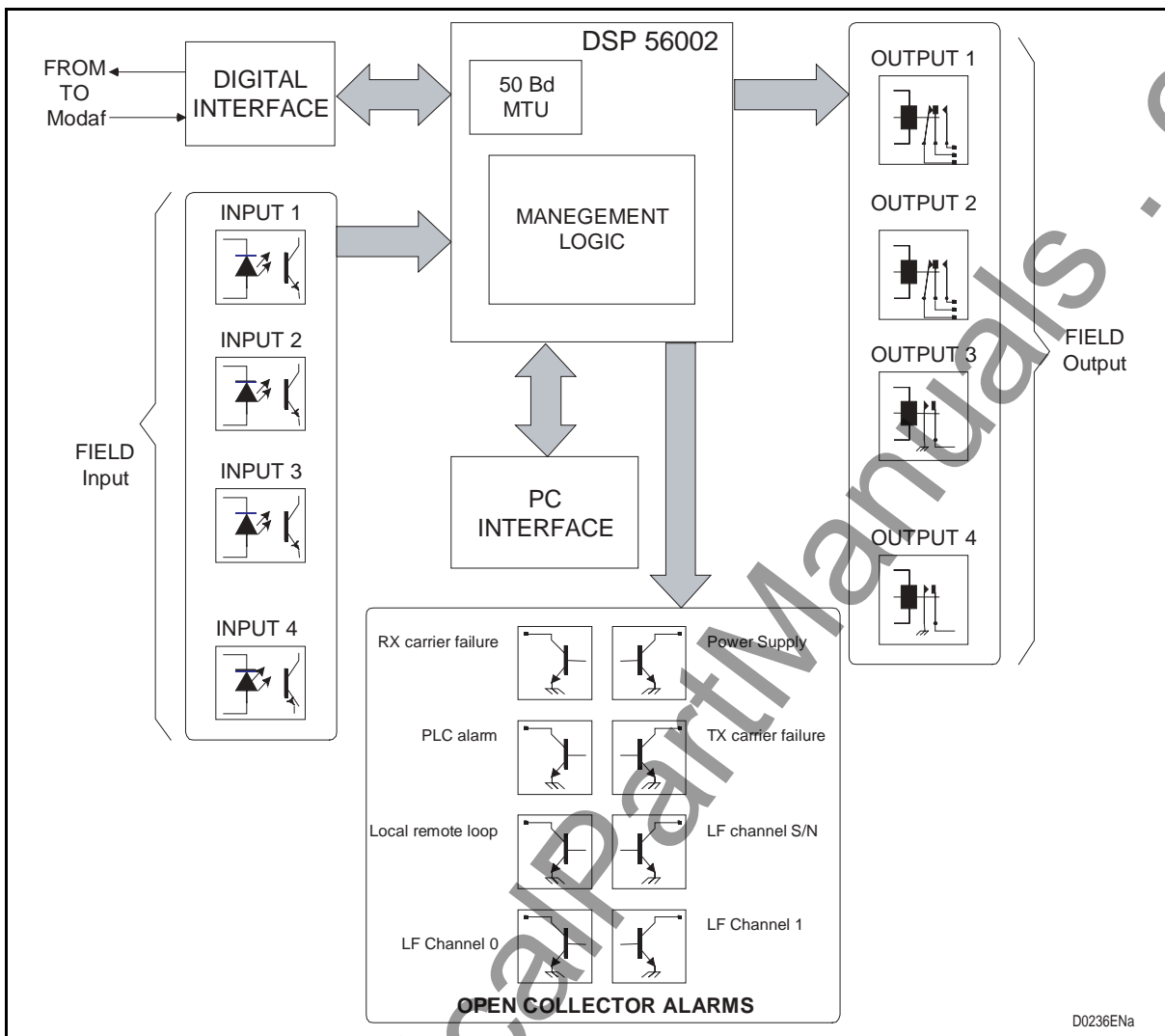

FIGURE 16 – SUPERVISION INTERFACE

Once the PC is connected to the remote PLC (ref. to chapter 1790B/EN HI), the INSU displays, on PC screen, the functions that can be performed in the remote terminal equipment.

DSP 56002 - MANAGEMENT logic AND 50 BAUD MTU

The DSP performs the connection with the remote PLC equipment carrying out:

- Reception and transmission of one 50 baud telegraph channel
- Management of communication protocol
- Data demodulation.
- Acknowledge of received information from the remote terminal.
- Logic management

COMMISSIONING

www.ElectricalPartManuals.com

www.ElectricalPartManuals.com

CONTENTS

1.	INTRODUCTION	5
2.	START UP AND OPERATION	6
2.1	Verification and Pre-setting	6
2.2	Motherboard	6
2.2.1	Power supply Jumpers	6
2.2.2	Set-up	6
2.3	POWER SUPPLY UNIT ed. 5	8
2.3.1	Factory setting	8
2.3.2	Switch I1	9
2.3.3	Fuse	9
2.4	Low frequency section board (LFS)	10
2.4.1	Pre-setting	10
2.4.2	LFS soldering jumpers description	12
2.4.3	LFS3 daughter board	13
2.5	Universal Call Converter	14
2.6	Transit interface (INTE)	17
2.7	Supervision interface (INSU)	19
2.8	High frequency modem (MODAF)	21
2.9	20 W amplifier (AMPL)	23
2.10	Transmission Line Interface (INTX)	24
2.10.1	Pre-setting	24
2.10.2	Transmission bandwidth programming	25
2.11	Reception Line Interface (INRX)	37
2.11.1	Pre-setting	37
2.11.2	HF Line impedance programming	38
2.11.3	Programming tables from 40 to 500 KHZ	40
3.	TEST AND COMMISSIONING	49
3.1	SW set-up	49
3.2	Required instruments	49
3.3	Preliminary operation	49
3.4	PLC local test	50
3.4.1	Power Supply	50
3.4.2	Transmission level	51
3.5	End to end LINE TEST	57
3.5.1	Overview	57
3.5.2	HF received signal	57

3.6	LF band EQUALISATION	59
3.7	LF received signal	59
3.8	LED INDICATION	59
3.9	LF end to end verification	60
3.9.1	Line response	60
3.9.2	Signalling verification	62
3.9.3	2/4 wires automatic exchange criteria	62
3.9.4	Alarms and LED'S verification	62
<hr/>		
4.	ANNEX	65
4.1	Speech channel	65
4.2	Telegraph channel	68

MODIFICATIONS PAGE

Version	DATE	COMMENTS
A	June 1998	ORIGINAL ISSUE
B	Dec. 1998	Modification of pages 9, 10, 11, 14, 15, 16, 33, 35, 36, 37, 38, 39, 41, 46, 47, 49, 52, 53, 54, 57, 64
C	Sept. 1999	New presentation + Modification of pages 10, 11, 14, 15, 51, 57, 64 (new page numbering)
D	May 2000	Modification of pages 10 and 11.
E	March 2004	New presentation + Description of the PLC1790B Revision 2
F	Sept. 2004	Minor change, editing for 2 side printing

BLANK PAGE

www.ElectricalPartManuals.com

1. INTRODUCTION

Completed the equipment installation, the operator has to proceed with the start-up, the line-up and the commissioning.

This chapter will describe the basic operation to perform these operation.

The **Step by Step procedures** for the commissioning of the Power Line Carrier PLC 1790/B REVISION2 link is described by the following flow chart

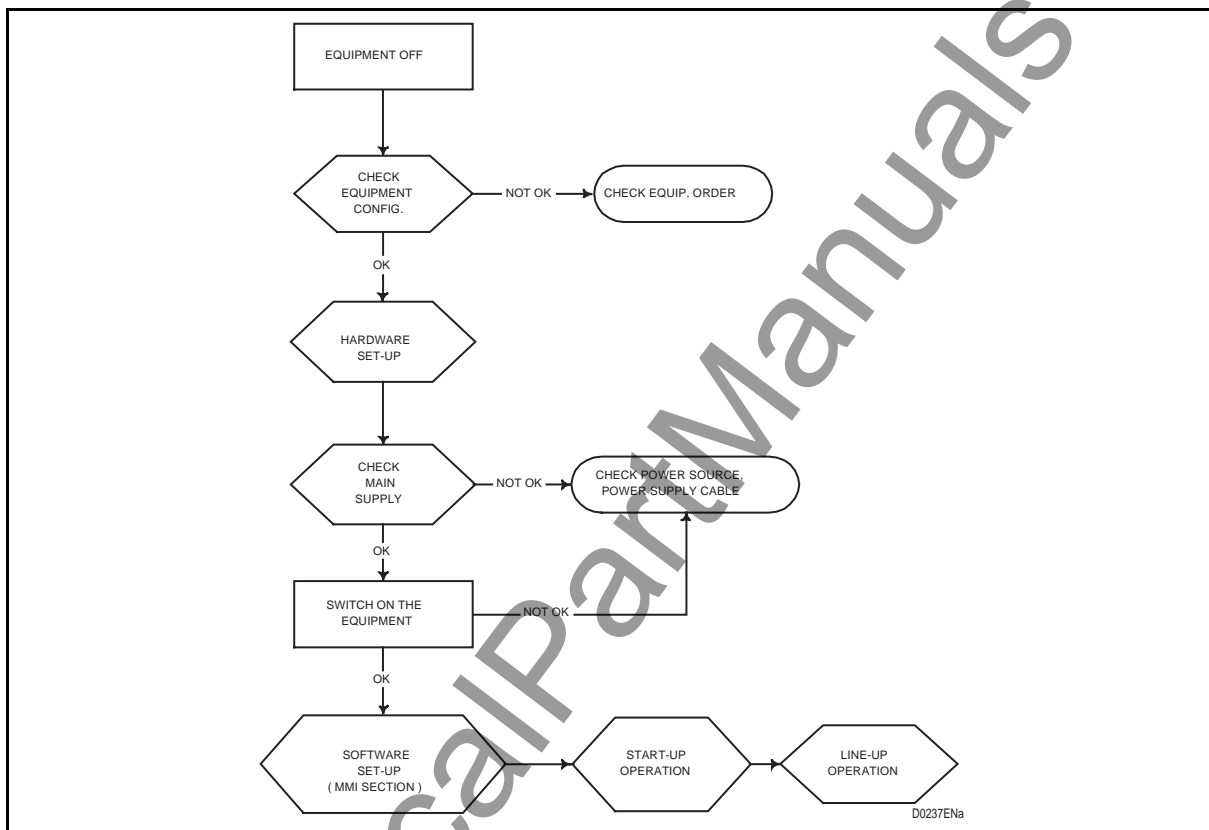

FIGURE 1 – COMMISSIONING FLOW CHART

2. START UP AND OPERATION

To avoid miss-operation disconnects all the cables coming from the field and then proceed with the start-up operations.

2.1 Verification and Pre-setting

According to the field requirement, the user can be called to modify the standard factory set-up. The next tables will show the hardware (HW) pre-setting for each single unit.

The jumpers named "FACTORY SET-UP" must not be changed.

No special tools are required to set up the single cards.

Group layout diagrams show the soldering jumpers location.

2.2 Motherboard

The PLC 1790/B REVISION2 motherboard is equipped with few soldering jumpers located both to the front side and to the backside. To have access to the backside, the operator has to remove the protection panel.

2.2.1 Power supply Jumpers

These jumpers are accessible from the front side of the equipment.

The power source, through two jumpers located on mother board, "A" and "B", can be grounded to the negative or the positive polarity.

Opening both "A" and "B" jumpers the power source will be floating

OPERATION	DIAGRAM REFERENCE	CONNECTIONS	
		CLOSED	OPEN
Balanced power supply			A(°)-B(°)
Power supply with ground positive pole		B(°)	A(°)
Power supply with ground negative pole		A(°)	B(°)

TABLE 1 – (°) A & B JUMPERS ARE LOCATED ON THE PLC MOTHER BOARD

2.2.2 Set-up

The factory set-up is given for information. As they are in the backside of the equipment the visual check as to be done only in case of maintenance.

OPERATION	DIAGRAM REFERENCE	CONNECTIONS	
		CLOSED	OPEN
Factory set-up	TC-1		1-2
	TC-2	1-2	
	TC-3	1-2	
	TC-4		1-2
	TC-8	1-2	
	TC-9	1-2	
Common PLC1&2 Alarm available on M13-M15-M17 and M14-M16-M18	TC-5	1-2	
	TC-6	1-2	
	TC-7	1-2	
PLC 1 & 2 alarm isolated. PLC1 on M13- M15-M17 and PLC2 on M14-M16-M18	TC-5		1-2
	TC-6		1-2
	TC-7		1-2

TABLE 2 – TC SET-UP

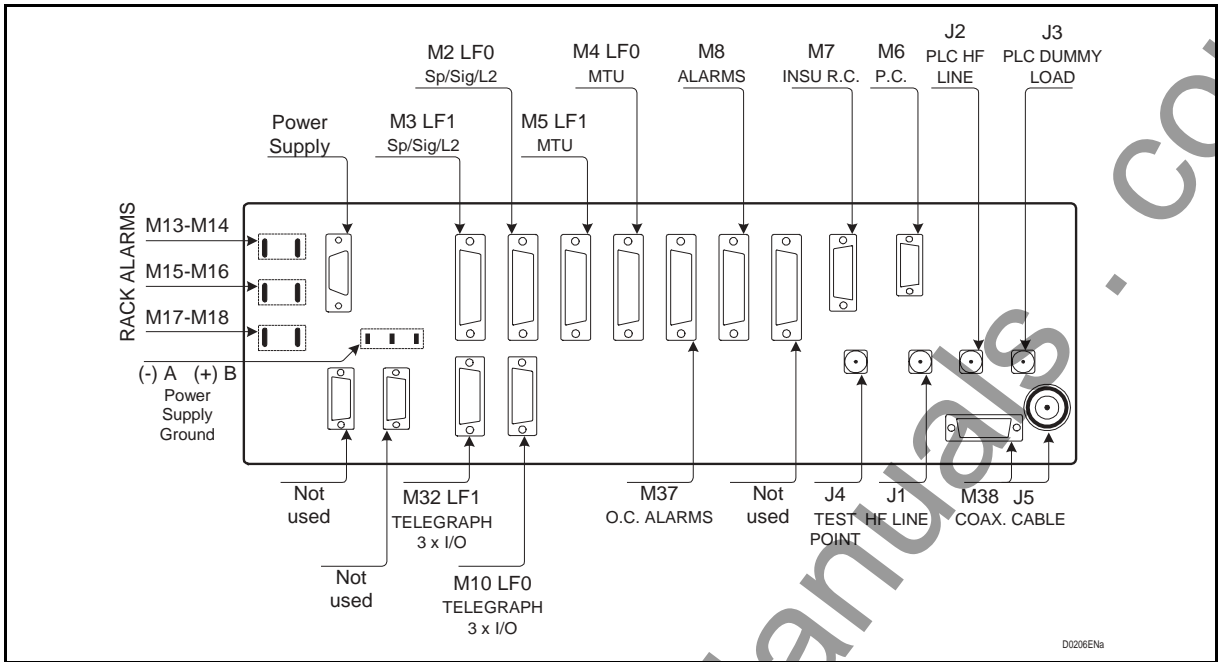

FIGURE 2 – FRONT SIDE PLC JUMPERS

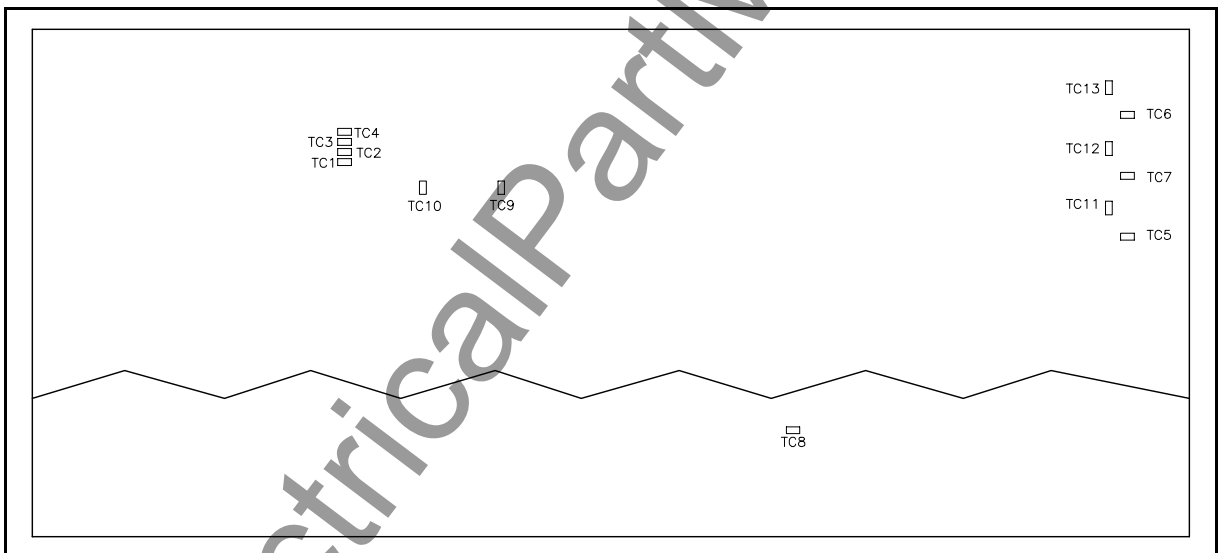

FIGURE 3 – BACK SIDE PLC JUMPERS

www.ElectricalPartManuals.com

2.3 POWER SUPPLY UNIT ed. 5

The factory settings are shown only for information, the board is protected by a cover which must not be removed.

2.3.1 Factory setting

The unit is programmed for 48 Vdc input voltage.

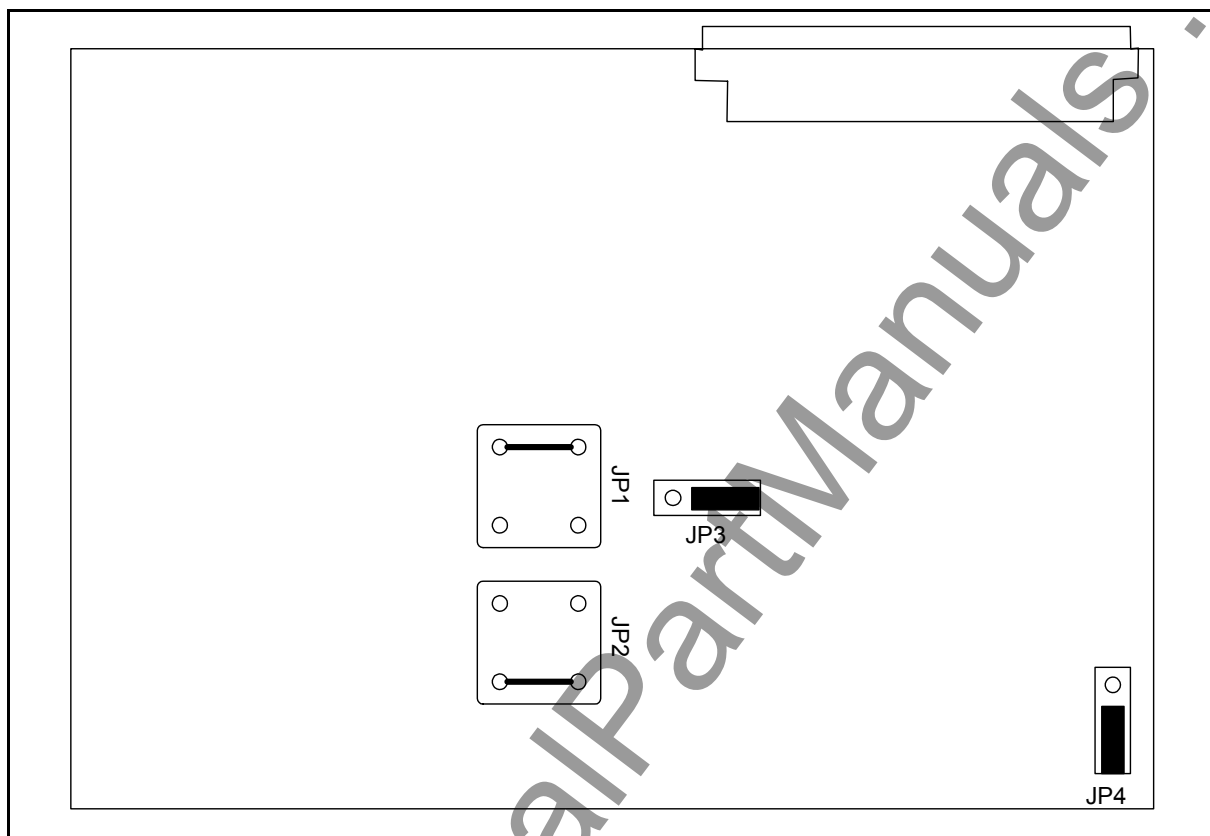

FIGURE 4 – ALIM 48 V_{DC} INPUT

2.3.2 Switch 1

The unit has the facility to change the switching frequency (as per table 2.3) in order to avoid interference with any eventual harmonic. This could be done either automatically by software or manually by hardware.

The module is equipped with an external accessible dipswitch used to modify the sampling frequency of the internal switching circuit.

Automatically by software:

The software of MODAF allows the automatic selection in such case the setting of the power supply is shown in the figure 2.4 below.

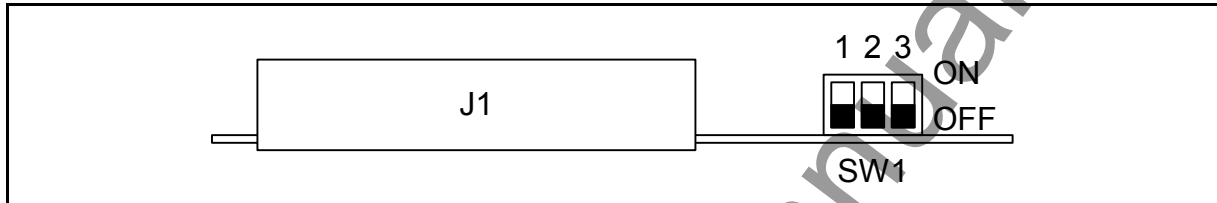

FIGURE 5 – ALIM SWITCH

Manually by hardware:

Frequency switching principle:

According to the RX band, the sampling frequency can be modified in the way to avoid that any eventual harmonic, 1st or 2nd level, will drop into the RX band +/- 8 kHz: i.e:

PLC RX Band 200-204 kHz

RX bandwidth= from (200-8) to (204+8)= 192 – 212 kHz

F_{SAMPLING}

F kHz	1 st Harmonic	2 nd harmonic	Selection
100	200	400	Not OK
134	268	536	OK

SAMPLING FREQUENCY kHz	SW1		
	I1	I2	I3
100	OFF	OFF	OFF
114	OFF	OFF	ON
134	OFF	ON	OFF
160	OFF	ON	ON

TABLE 3 – SAMPLING FREQUENCY TABLE

2.3.3 Fuse

A fuse is accessible without opening the cover

2.4 Low frequency section board (LFS)

2.4.1 Pre-setting

Verify and pre-set the unit according to the field characteristics, only the factory setting are shown below. The LFS board have two the references:

411.410.034 when used without daughter board (LFS)

411.410.035 when used with daughter board (LFS3)

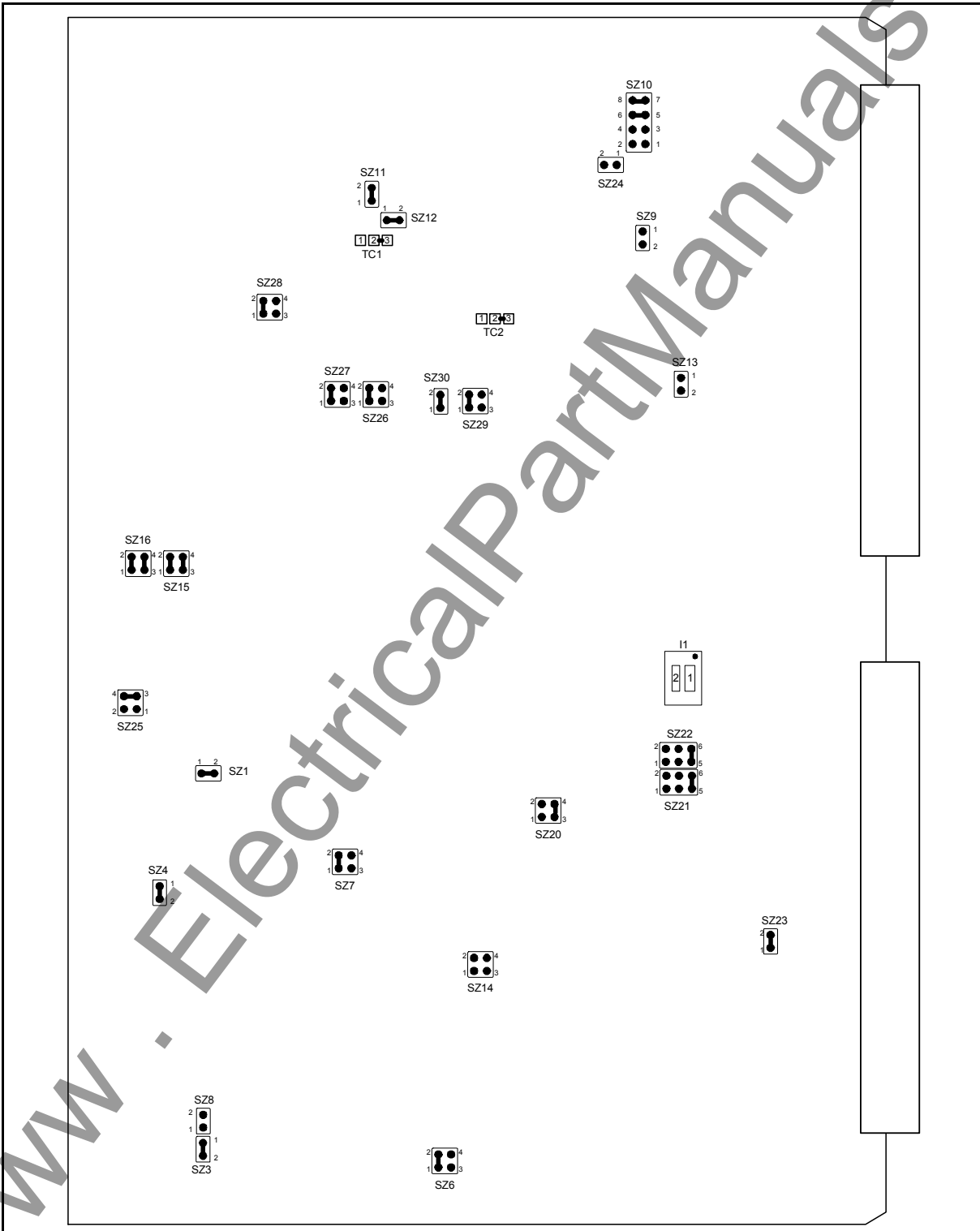

FIGURE 6 – LFS 411.410.034 FACTORY JUMPERS LAY-OUT

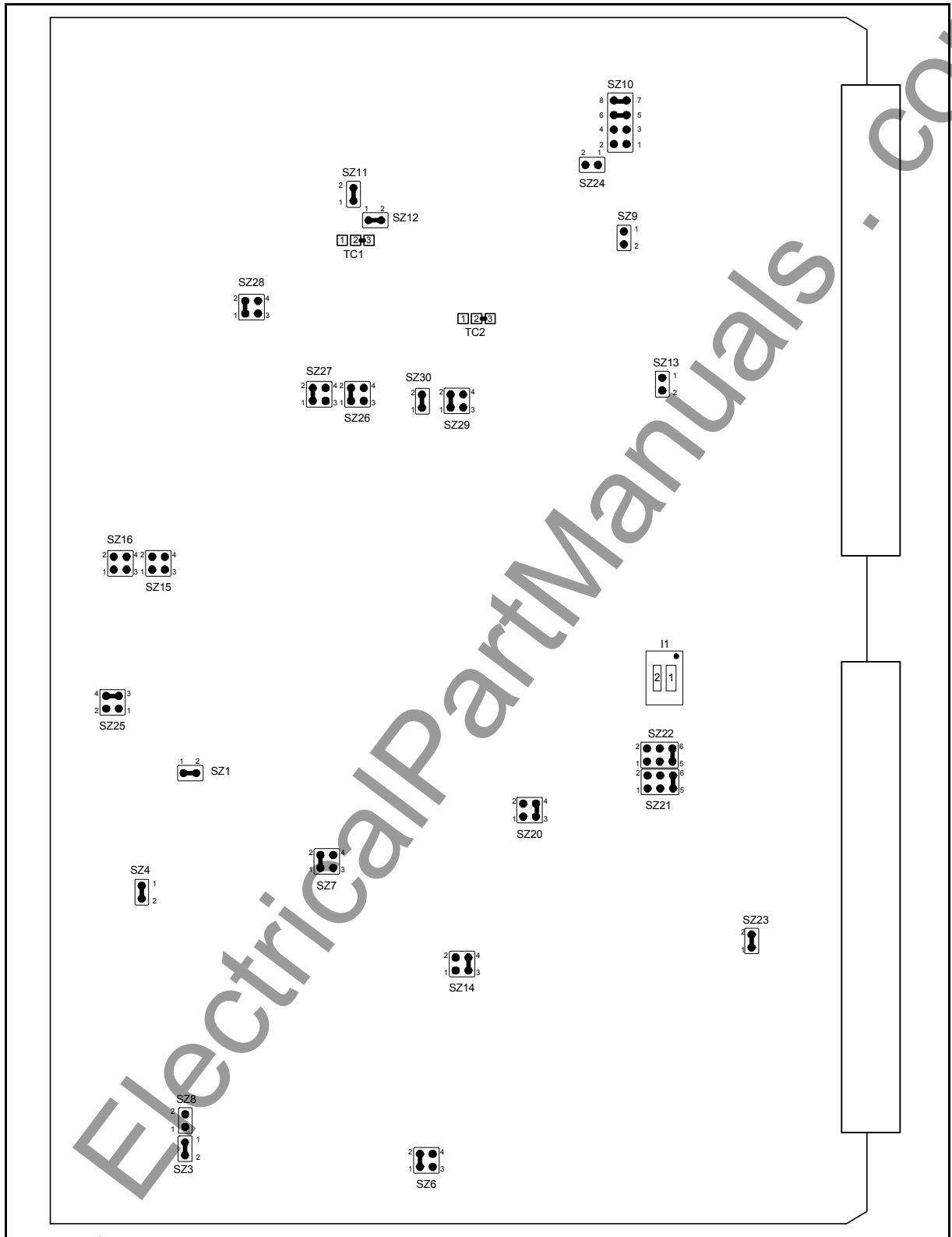

FIGURE 7 – LFS 411.410.035 FACTORY JUMPERS LAY-OUT

2.4.2 LFS soldering jumpers description

OPERATION	DIAGRAM REFERENCE	JUMPERS	
		CLOSED	OPEN
Factory Set-up	SZ1	1-2	
	SZ3	1-2	
	SZ4	1-2	
	SZ6	1-2	3-4
	SZ7	1-2	3-4
	SZ8		1-2
	SZ11	1-2	
	SZ12	1-2	
	SZ23	1-2	
	SZ25	3-4	1-2
	SZ26	1-2	3-4
	SZ27	1-2	3-4
	SZ28	1-2	3-4
	SZ29	1-2	3-4
	SZ30	1-2	
TC1	2-3		
TC2	2-3		
LFS set-up (without daughter board)	SZ14		1-2; 3-4
	SZ15	1-2; 3-4	
	SZ16	1-2; 3-4	
LFS3 set-up (with daughter board)	SZ14	3-4	1-2
	SZ15		1-2; 3-4
	SZ16		1-2; 3-4
RX LF Service Suppression "-" Wire Internal source $\leq 15 V_{DC}$ reference*	SZ9	1-2	
	SZ13	1-2	
RX LF Service Suppression "-" Wire External source Reference (max. $210 V_{DC}$)	SZ9		1-2
	SZ13		1-2
Configuration with CCUN	SZ10	1-2 3-4	5-6 7-8
	SZ24	1-2	
Configuration without CCUN	SZ10	5-6 7-8	1-2 3-4
	SZ24		1-2
"M" Wire to Exchange equipment "E" Wire from Exchange equipment	SZ21	5-6	1-2, 3-4
	SZ22	5-6	1-2, 3-4
"M" Wire to CCUN "E" Wire from CCUN	SZ21	3-4, 5-6	1-2
	SZ22	3-4	1-2, 5-6
TX Signalling	SZ20	1-2 (Disable)	1-2 (Enable)
Compandor	SZ20	3-4 (Disable)	3-4 (Enable)
Internal modem I1 (Dip Switch)	1 - RTS	CTS on RTS	Permanent CTS
	2 - DTR	DSR on DTR	Permanent DSR

TABLE 4 – LFS JUMPERS

*** Important notice: The equipment will be damaged if by mistake this setting is used with external source reference.**

2.4.3 LFS3 daughter board

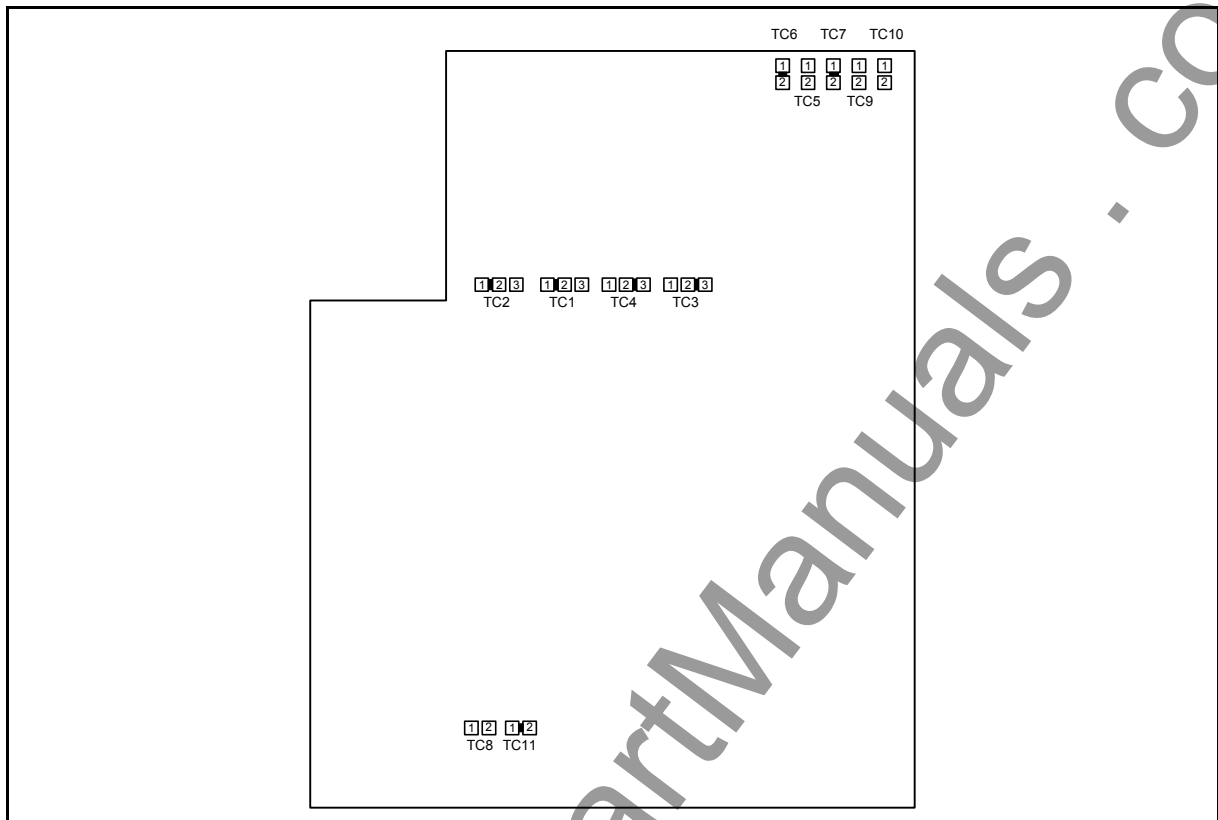

FIGURE 8 – LFS-3 DAUGHTER BOARD STRAPS LAY-OUT

OPERATION	DIAGRAM REFERENCE	CONNECTIONS	
		CLOSED	OPEN
Factory set-up	TC-1	1-2	
	TC-2	2-3	
	TC-3	1-2	
	TC-4	2-3	
	TC-7	1-2	
	TC-8		1-2
	TC-9		1-2
	TC-10		1-2
	TC-11	1-2	
8 BIT WORD / ASYNC	TC-5		1-2
	TC-6		1-2
9 BIT WORD / ASYNC	TC-5	1-2	
	TC-6		1-2
10 BIT WORD / ASYNC	TC-5		1-2
	TC-6	1-2	
11 BIT WORD / ASYNC	TC-5	1-2	
	TC-6	1-2	

TABLE 5 – LFS-3 DAUGHTER BOARD STRAPS

NOTE: The bit word includes also the START and STOP Bits

2.5 Universal Call Converter

Verify and pre-set the card according to the field request:

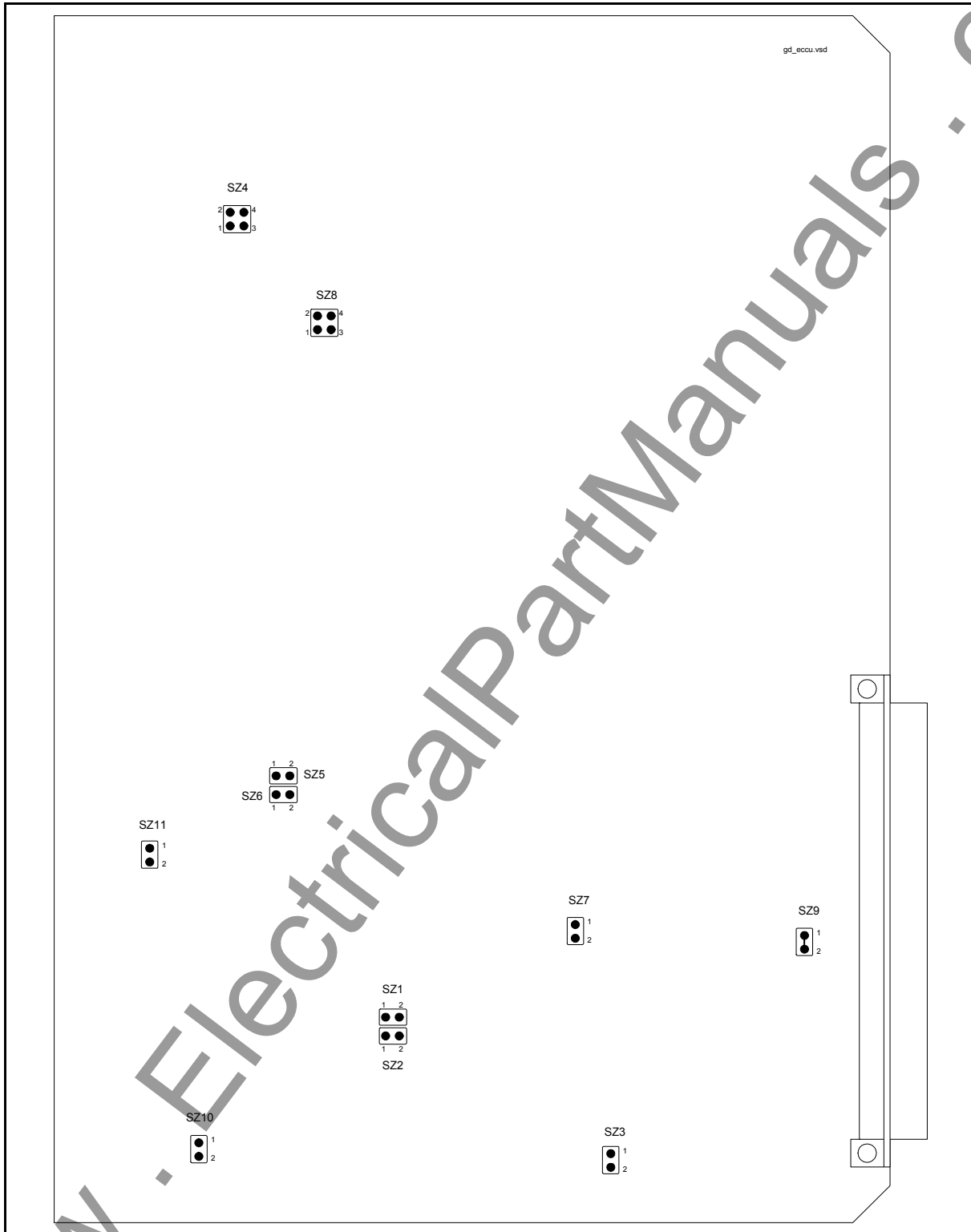

FIGURE 9 – 8 CCUN JUMPERS LAYOUT

CCUN soldering jumpers description

OPERATION	DIAGRAM REFERENCE	CONNECTIONS	
		CLOSED	OPEN
CCUN-1 (LFS-0)			
PLA-T CONFIGURATION (FXS)	SZ1	1-2	
	SZ2	1-2	
	SZ3		1-2
	SZ4		1-2 3-4
	SZ10		1-2
BC CONFIGURATION (HOT LINE)	SZ1	1-2	
	SZ2	1-2	
	SZ3		1-2
	SZ4	3-4	1-2
	SZ10		1-2
PLA-C CONFIGURATION (FXO)	SZ1		1-2
	SZ2		1-2
	SZ3	1-2	
	SZ4	1-2	3-4
	SZ10	1-2	
BL CONFIGURATION (Not used)	SZ1		1-2
	SZ2		1-2
	SZ3		1-2
	SZ4	1-2 3-4	
	SZ10	1-2	
CCUN-2 (LFS-1)			
PLA-T CONFIGURATION (FXS)	SZ5	1-2	
	SZ6	1-2	
	SZ7		1-2
	SZ8		1-2 3-4
	SZ11		1-2
BC CONFIGURATION (HOT LINE)	SZ5	1-2	
	SZ6	1-2	
	SZ7		1-2
	SZ8	3-4	1-2
	SZ11		1-2
PLA-C CONFIGURATION (FXO)	SZ5		1-2
	SZ6		1-2
	SZ7	1-2	
	SZ8	1-2	3-4
	SZ11	1-2	

OPERATION	DIAGRAM REFERENCE	CONNECTIONS	
		CLOSED	OPEN
BL CONFIGURATION (Not used)	SZ5		1-2
	SZ6		1-2
	SZ7		1-2
	SZ8	1-2 3-4	
	SZ11	1-2	
Analogue / digital ground link	SZ9	1-2	

TABLE 6 – CCUN JUMPERS

BL = Hot Line with local battery**BC** = Hot Line with central battery;**FXO** = Remote subscriber exchange side**FXS** = Remote subscriber telephone side

2.6 Transit interface (INTE)

Verify and pre-set the card according to the field request:

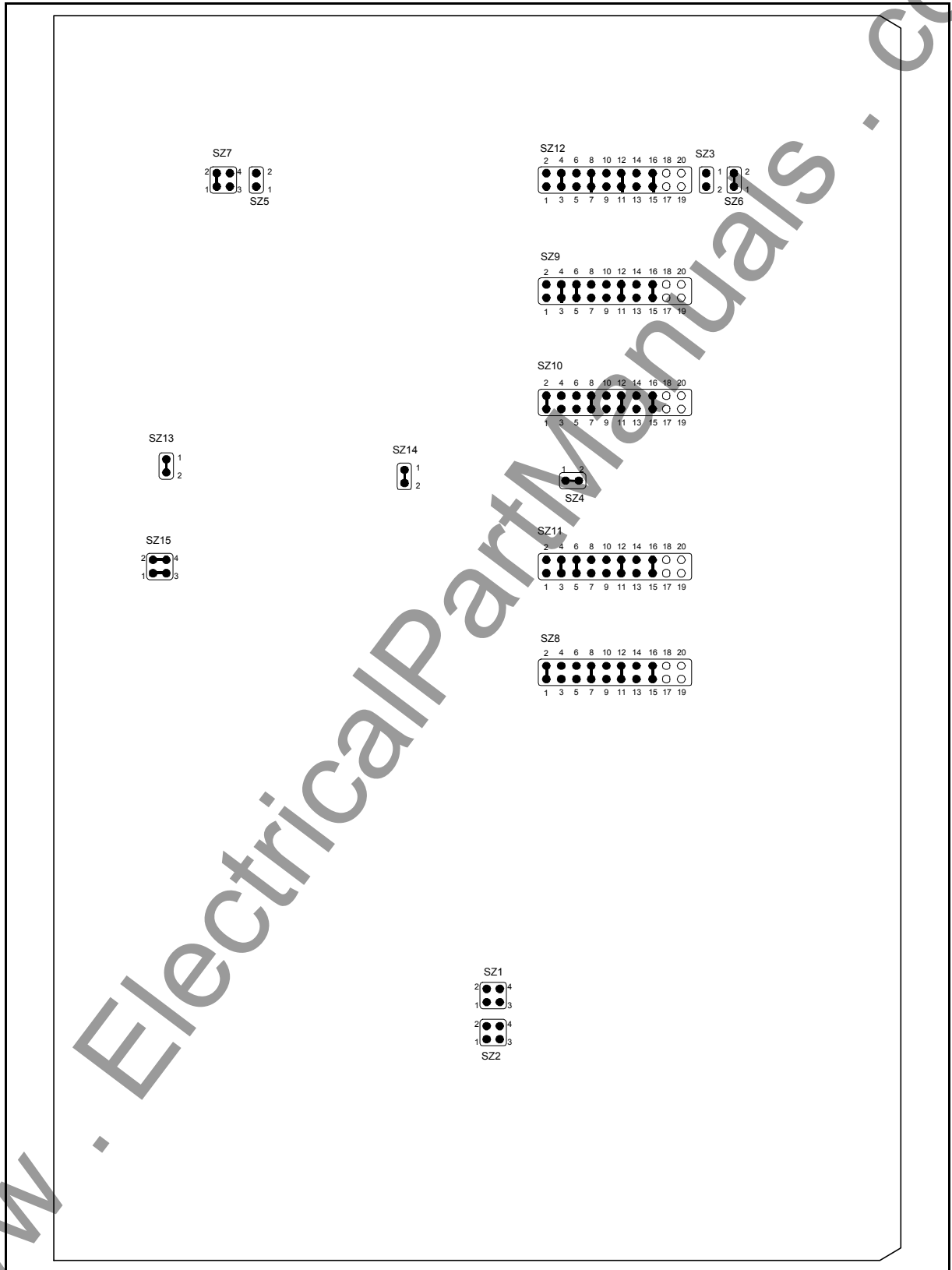

FIGURE 10 – INTE JUMPERS LAYOUT

INTE soldering jumpers description:

OPERATION	DIAGRAM REFERENCE	CONNECTIONS	
		CLOSED	OPEN
COMMON JUMPERS			
Enable CH-0	SZ1	1-2	3-4
	SZ2	3-4	1-2
Enable CH-1	SZ1	3-4	1-2
	SZ2	1-2	3-4
Enable both channels	SZ1	1-2	3-4
	SZ2	1-2	3-4
Digital loop test disable (both channels)	SZ15	1-3 2-4	
Digital loop test enable (both channels)	SZ15	3-4	1-2
Factory set-up	SZ3		1-2
	SZ4	1-2	
	SZ5		1-2
	SZ6	1-2	
	SZ7	1-2	3-4
	SZ12	3-4 7-8 11-12 15-16	
	SZ13	1-2	
	SZ14	1-2	
CHANNEL 0			
RX attenuator (for -18 dBm output)	SZ10	set 8 dB	
TX attenuator (for -18 dBm input)	SZ9	set 4 dB	
CHANNEL 1			
RX attenuator (for -18 dBm output)	SZ8	set 8 dB	
TX attenuator (for -18 dBm input)	SZ11	set 4 dB	

TABLE 7 – INTE JUMPERS

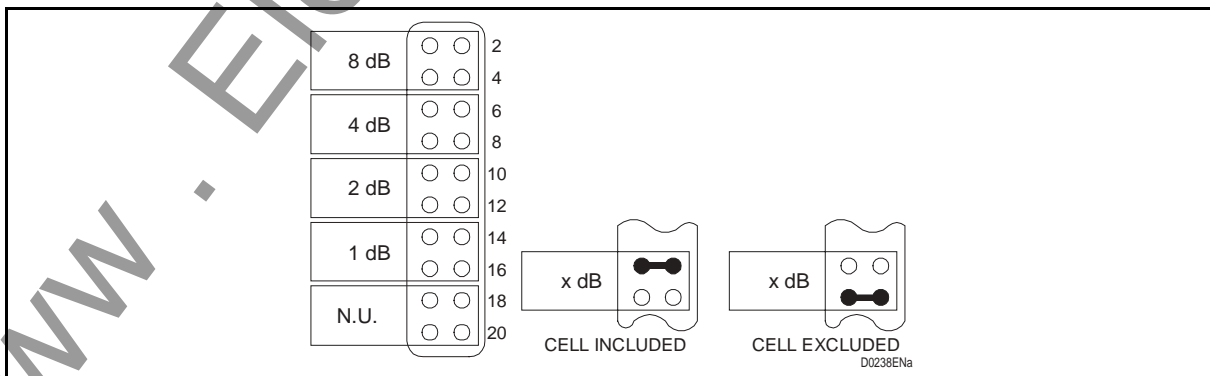

FIGURE 11 – INPUT / OUTPUT ATTENUATION CELL

2.7 Supervision interface (INSU)

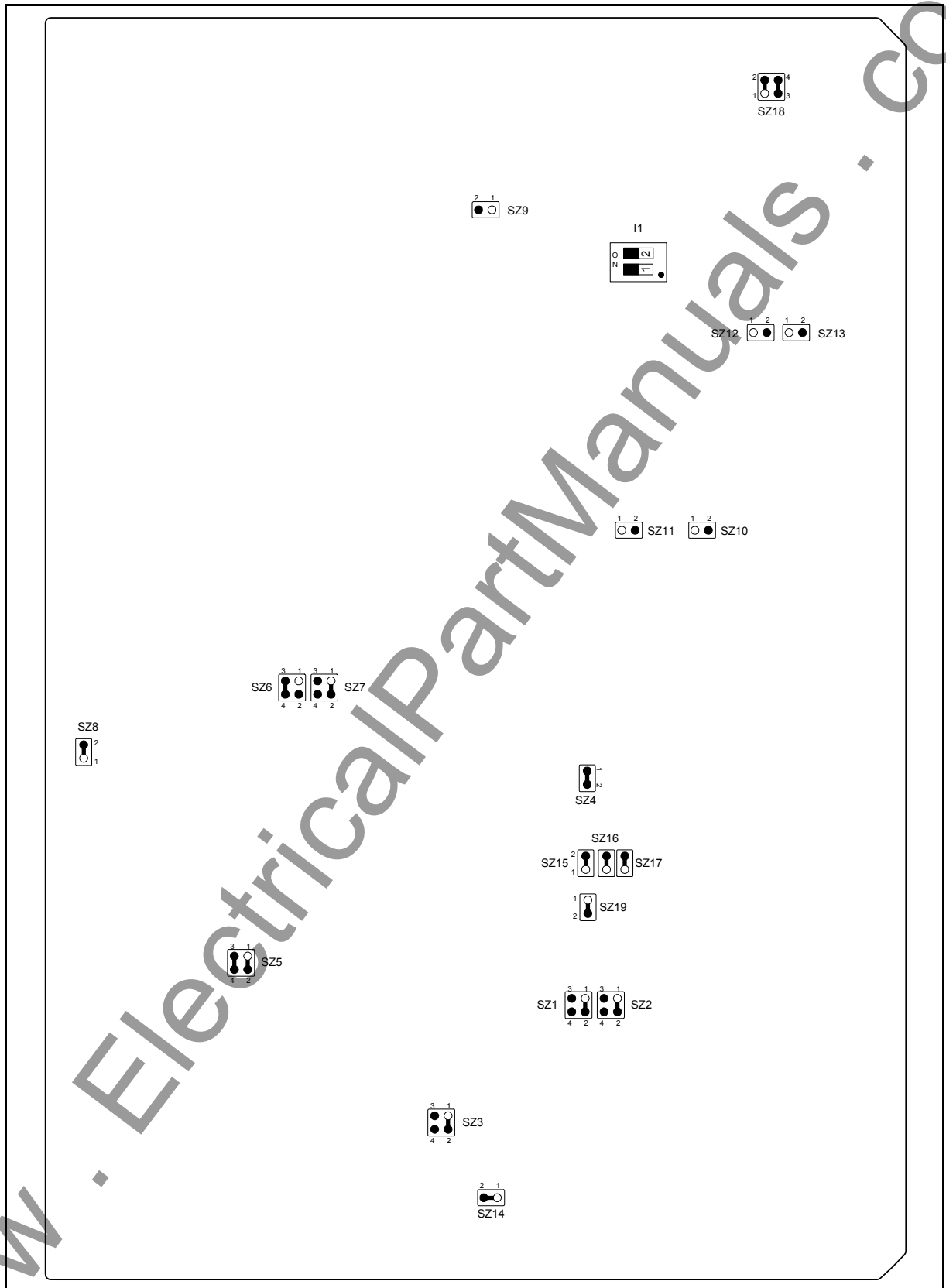

FIGURE 12 – INSU JUMPERS LAYOUT

INSU soldering straps description

OPERATION	DIAGRAM REFERENCE	CONNECTIONS	
		CLOSED	OPEN
Factory set-up	SZ1	1-2	3-4
	SZ2	1-2	3-4
	SZ3	1-2	3-4
	SZ4	1-2	
	SZ5	1-2 3-4	
	SZ6	3-4	1-2
	SZ7	1-2	3-4
	SZ8	1-2	
Loop alarm common wire as ground reference	SZ9	1-2	
Loop alarm common wire as free voltage	SZ9		1-2
Remote common 1 common wire as ground reference	SZ10	1-2	
Remote common 1 common wire as free voltage	SZ10		1-2
Remote common 2 common wire as ground reference	SZ11	1-2	
Remote common 2 common wire as free voltage	SZ11		1-2
Factory set-up	SZ12	1-2	1-2
	SZ13	1-2	1-2
	SZ14	1-2	
	SZ15	1-2	1-2
	SZ16	1-2	
	SZ17	1-2	
	SZ18	1-2 ; 3-4	
	SZ19	1-2	
	I1	NOT USED	

TABLE 8 – INSU JUMPERS

2.8 High frequency modem (MODAF)

Verify the following jumpers:

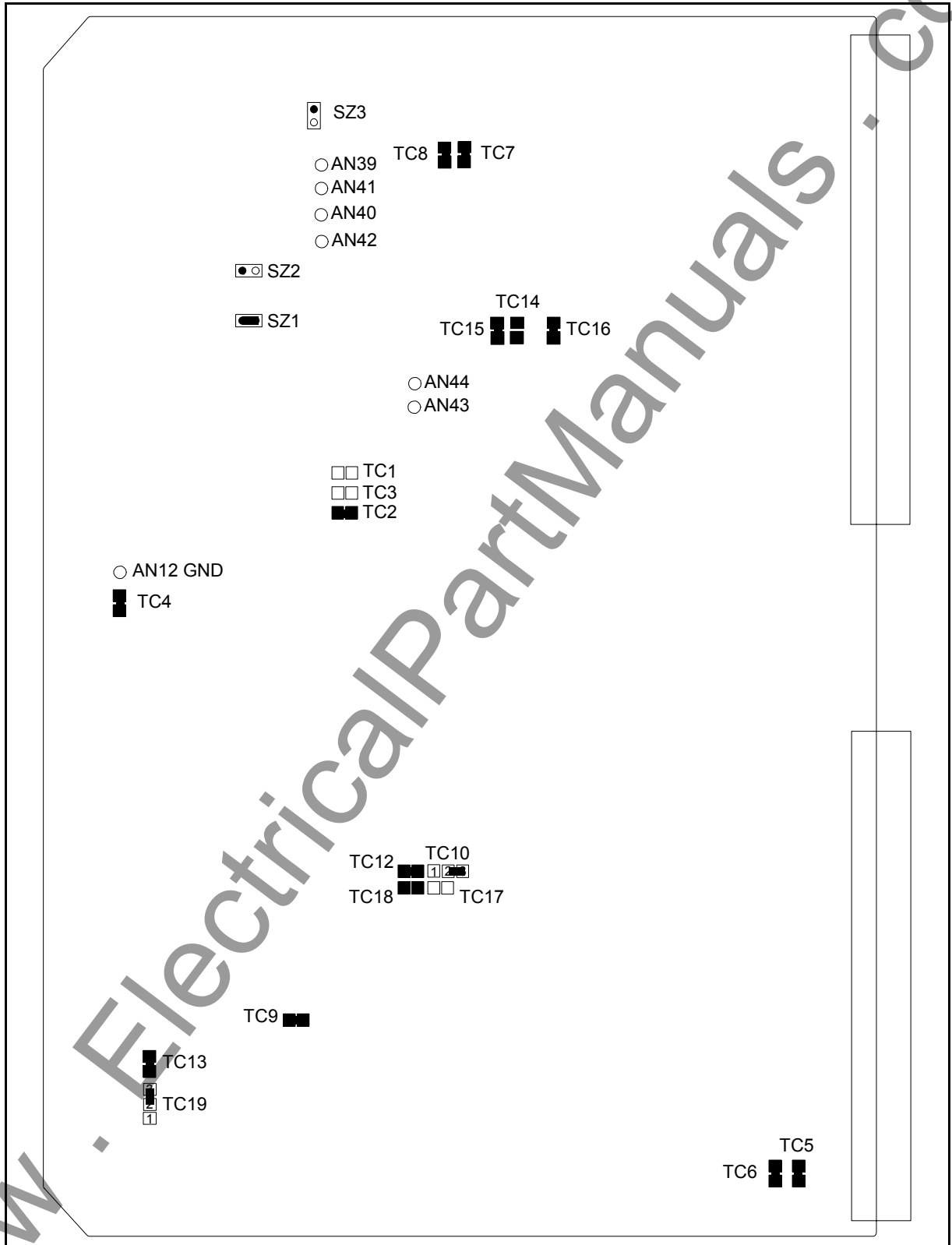

FIGURE 13 – MODAF JUMPERS LAYOUT

MODAF soldering jumpers description

OPERATION	DIAGRAM REFERENCE	CONNECTIONS	
		CLOSED	OPEN
Factory set-up	TC2	1-2	
	TC4	1-2	
	TC7	1-2	
	TC8	1-2	
	TC9	1-2	
	TC12	1-2	
	TC13	1-2	
	TC14		1-2
	TC15	1-2	
	TC16	1-2	
	TC17		1-2
	TC18		1-2
	TC19	2-3	1-2
	TC10	2-3	1-2
	SZ1	1-2	
Input Attenuator 7 dB Excluded (Standard configuration)	TC1	1-2	
	TC3		1-2
Input Attenuator 7 dB Included (very low HF line attenuation)	TC1		1-2
	TC3	1-2	
ALIM Switching frequency controlled by DSP	TC5	1-2	
	TC6	1-2	
ALIM Switching frequency to be controlled manually	TC5		1-2
	TC6		1-2
HF Power 10 W	SZ2	1-2	
HF Power 20/40 W	SZ2		1-2
1 HF Power Amplifier (AMPL1 -> 10/20W)	SZ3	1-2	
2 HF Power Amplifier (AMPL1 + AMPL2 -> 40W)	SZ3		1-2

TABLE 9 – MODAF JUMPERS

MODAF soldering point

OPERATION	DIAGRAM REFERENCE
GROUND	AN 12; AN 39
	AN 42; AN 44
	AN 42
TX HF 1	AN 40
TX HF 2	AN 41
RX HF	AN 43

TABLE 10 – MODAF JUMPERS

2.9 20 W amplifier (AMPL)

Verify the card pre-setting:

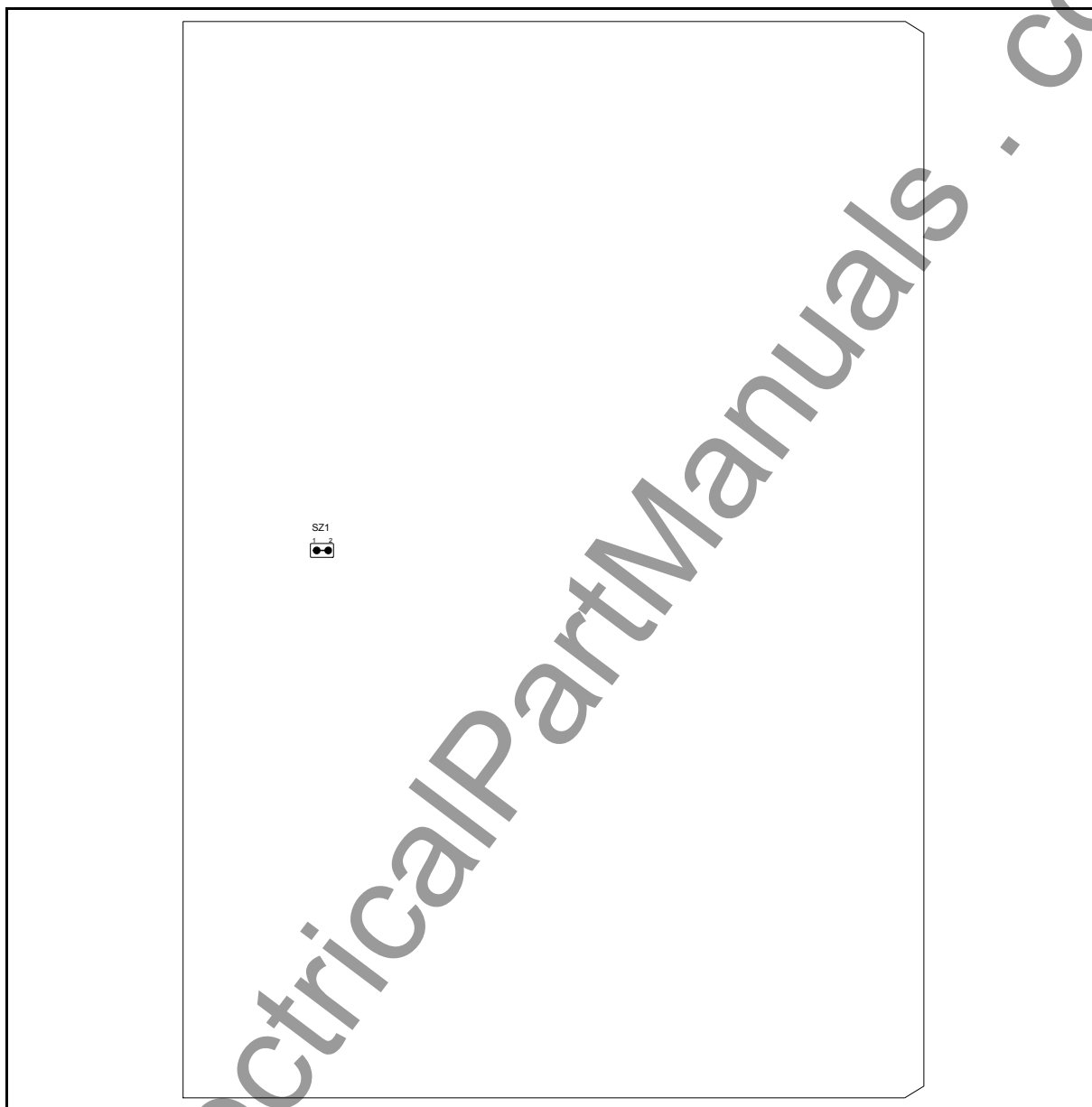

FIGURE 14 – AMPL JUMPER LAYOUT

AMPL soldering jumper description:

OPERATION	DIAGRAM REFERENCE	CONNECTIONS	
		CLOSED	OPEN
Factory Set-up	SZ1	1-2	

TABLE 11 – AMPL JUMPER

2.10 Transmission Line Interface (INTX)

2.10.1 Pre-setting

Verify and pre-set the card according to the field request:

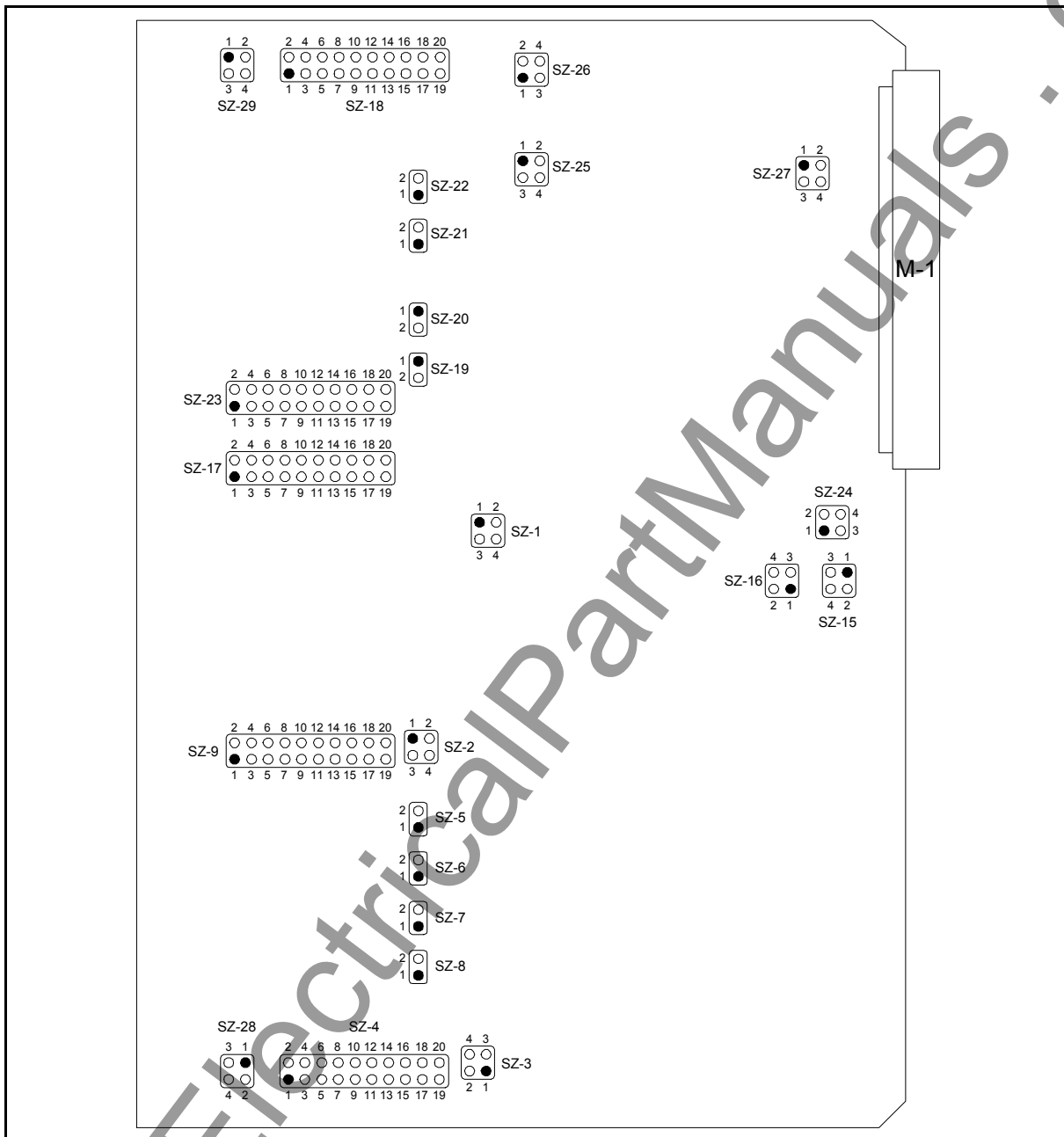

FIGURE 15 – INTX JUMPERS LAYOUT

INTX Power Amplifier additional soldering jumpers:

OPERATION	DIAGRAM REFERENCE	CONNECTIONS	
		CLOSED	OPEN
Single Power Amplifier	SZ15	1-2	3-4
Double Power Amplifier	SZ15	1-3 2-4	

TABLE 12 – INTX JUMPERS

2.10.2 Transmission bandwidth programming

In the following one and double channels transmission filter programming tables, from 40 to 500 kHz, are listed.

The PLC transmission filter can be tuned at any 1 kHz step, between 40 and 500 kHz, using the same jumpers of the closest standard transmission channels reported on the tables.

2.10.2.1 Double channel filter

Band 40 ÷ 248 kHz

kHz	SZ4-SZ23	SZ5 SZ19	SZ6 SZ20	SZ7 SZ21	SZ8 SZ22	SZ9-SZ18	SZ17
40-48	1-2 5-6 9-10 13-14 17-18					1-2 5-6 9-10 13-14 17- 18	1-2 3-4 7-8 11-12
48-56	1-2 9-10 13-14 17- 18	1-2				1-2 7-8 9-10 13-14 19- 20	1-2 3-4 9-10
56-64	1-2 5-6 13-14				1-2	1-2 7-8 13-14 19-20	1-2 5-6 7-8 13-14
64-72	5-6 13-14					5-6 13-14	1-2 9-10
72-80	1-2 13-14 17-18	1-2				5-6 13-14 17-18	1-2
80-88	1-2 9-10				1-2	3-4 9-10 13-14 19-20	3-4 5-6 7-8 11-12 13- 14
88-96	1-2 17-18	1-2				5-6 17-18	3-4 5-6 9-10
96-104	1-2 7-8 19-20	1-2				5-6 17-18	3-4 5-6 13-14
104-112	1-2 5-6 17-18		1-2			3-4 7-8 9-10 19-20	3-4 9-10 11-12 13-14
112-120	1-2 7-8 15-16	1-2	1-2			9-10 13-14	3-4 9-10 13-14
120-128	5-6 17-18			1-2		7-8 9-10 15-16 17-18	3-4 9-10
128-136	3-4 9-10 15-16	1-2		1-2	1-2	3-4 5-6 15-16 17-18	3-4 11-12 13-14
136-144	1-2 7-8 15-16				1-2	3-4 7-8 13-14 19-20	3-4 11-12
144-152	3-4 9-10 15-16			1-2	1-2	3-4 13-14 19-20	3-4 13-14
152-160	1-2 7-8 11-12	1-2		1-2	1-2	11-12 13-14 19-20	3-4
160-168	1-2 7-8 11-12 15-16					3-4 7-8 11-12 13-14 19-20	5-6 7-8 9-10
168-176	1-2 7-8 15-16					3-4 7-8 13-14	5-6 7-8 11-12 13-14
176-184	1-2 7-8 11-12	1-2		1-2		13-14	5-6 7-8 11-12
184-192	1-2 7-8 19-20	1-2				17-18	5-6 7-8 13-14
192-200	1-2 7-8 11-12	1-2			1-2	7-8 11-12 15-16 17-18	5-6 7-8
200-208	3-4 7-8 9-10 15-16 19-20					3-4 7-8 11-12 15-16 17-18	5-6 9-10 13-14
208-216	13-14				1-2	17-18	7-8 9-10 11-12
216-224	13-14				1-2	17-18	7-8 9-10 13-14
224-232	1-2 7-8 11-12 15-16				1-2	3-4 7-8 11-12 17-18	5-6 11-12 13-14
232-240	1-2 7-8 15-16				1-2	3-4 7-8 17-18	5-6 11-12
240-248	1-2	1-2	1-2	1-2	1-2	17-18	7-8 11-12

The following connections are common for all the above frequencies

SZ2-SZ3-SZ24-SZ25	SZ1-SZ26	SZ16	SZ27	SZ28-SZ29
1-2	1-3	3-4	3-4	3-4

Band 248 ÷ 456 kHz

kHz	SZ4-SZ23	SZ5 SZ19	SZ6 SZ20	SZ7 SZ21	SZ8 SZ22	SZ9-SZ18	SZ17
248-256	1-2 7-8 15-16	1-2			1-2	7-8 13-14 19-20	1-2 13-14
256-264	1-2 7-8 15-16				1-2	3-4 7-8 13-14 19-20	3-4 5-6 7-8 9-10 13-14
264-272	3-4 5-6 15-16				1-2	1-2 7-8 15-16 17-18	3-4 5-6 7-8 9-10
272-280	3-4 5-6 11-12 15-16 19-20					3-4 7-8 11-12 13-14 17-18	3-4 5-6 7-8 11-12 13-14
280-288	1-2 5-6 9-10			1-2		3-4 7-8 11-12 13-14	3-4 5-6 7-8 11-12
288-296	1-2 7-8 11-12	1-2		1-2	1-2	11-12 13-14 19-20	3-4 5-6 7-8 13-14
296-304	1-2 7-8 11-12	1-2		1-2	1-2	11-12 13-14 19-20	3-4 5-6 7-8
304-312	1-2 7-8 11-12	1-2		1-2	1-2	11-12 13-14 19-20	3-4 5-6 9-10 13-14
312-320	1-2 7-8 11-12 15-16 19-20					3-4 7-8 11-12 13-14 19-20	3-4 5-6 11-12 13-14
320-328	1-2 7-8 15-16					3-4 7-8 13-14	5-6 11-12 13-14
328-336	1-2 7-8 15-16					3-4 7-8 13-14	3-4 5-6 13-14
336-344	1-2 7-8 11-12	1-2		1-2		13-14	3-4 7-8 11-12
344-352	5-6		1-2	1-2		13-14	3-4 7-8 13-14
352-360	5-6		1-2	1-2		13-14	3-4 7-8 13-14
360-368	9-10 13-14				1-2	11-12 15-16 17-18	3-4 9-10 11-12
368-376	1-2 7-8 15-16 19-20				1-2	3-4 7-8 15-16 17-18	3-4 9-10 13-14
376-384	1-2 7-8 15-16 19-20					3-4 7-8 15-16 17-18	3-4 9-10
384-392	1-2 11-12 19-20					3-4 11-12 17-18	3-4 11-12 13-14
392-400	1-2 11-12 19-20					3-4 11-12 17-18	5-6 7-8 9-10 11-12 13-14
400-408	1-2 11-12 19-20					3-4 11-12 17-18	5-6 7-8 9-10 11-12
408-416	1-2 11-12 19-20					3-4 11-12 17-18	5-6 7-8 9-10 13-14
416-424	1-2 11-12 19-20					3-4 11-12 17-18	5-6 7-8 9-10
424-432	13-14				1-2	17-18	5-6 7-8 11-12 13-14
432-440	13-14				1-2	17-18	5-6 7-8 11-12
440-448	13-14				1-2	17-18	5-6 7-8 13-14
448-456	1-2 7-8 15-16				1-2	3-4 7-8 17-18	5-6 7-8 13-14

The following connections are common for all the above frequencies

SZ2-SZ3-SZ24-SZ25	SZ1-SZ26	SZ16	SZ27	SZ28-SZ29
3-4	1-2 3-4	3-4	3-4	3-4

Band 456 ÷ 472 kHz

kHz	SZ4-SZ23	SZ5-SZ19	SZ6-SZ20	SZ7-SZ21	SZ8-SZ22	SZ9-SZ18	SZ17
456-464	1-2 7-8 15-16				1-2	3-4 7-8 17-18	5-6 7-8
464-472	1-2 7-8 15-16				1-2	3-4 7-8 17-18	5-6 7-8

The following connections are common for all the above frequencies

SZ2-SZ3-SZ24-SZ25	SZ1-SZ26	SZ16	SZ27	SZ28-SZ29
3-4	1-2 3-4	3-4	3-4	3-4

Band 472 ÷ 496 kHz

kHz	SZ4-SZ23	SZ5-SZ19	SZ6-SZ20	SZ7-SZ21	SZ8-SZ22	SZ9-SZ18	SZ17
472-480	1-2	1-2	1-2	1-2	1-2	17-18	5-6 9-10 13-14
480-488	1-2	1-2	1-2	1-2	1-2	17-18	5-6 9-10 13-14
488-496	1-2	1-2	1-2	1-2	1-2	17-18	5-6 9-10 13-14

The following connections are common for all the above frequencies

SZ2-SZ3-SZ24-SZ25	SZ1-SZ26	SZ16	SZ27	SZ28-SZ29
3-4	1-2 3-4	1-2	3-4	3-4

TABLE 13 – INTX DOUBLE CHANNEL JUMPERS

www.ElectricalPartManuals.com

2.10.2.2 Single channel filter

Band 44 ÷ 144 kHz

kHz	SZ4-SZ23	SZ5 SZ19	SZ6 SZ20	SZ7- SZ21	SZ8- SZ22	SZ9-SZ18	SZ17
40-44	1-2 5-6 9-10 13-14 17-18					1-2 5-6 9-10 13-14 17-18	1-2 3-4 5-6 7-8 9-10
44-48	1-2 5-6 9-10					1-2 5-6 9-10	1-2 3-4 5-6 9-10 11-12 13-14
48-52	1-2 9-10 13-14 17-18	1-2				1-2 7-8 9-10 13-14 19-20	1-2 3-4 5-6 9-10 13-14
52-56	1-2 5-6 9-10 17-18			1-2		3-4 5-6 9-10 15-16 17-18	1-2 3-4 5-6
56-60	1-2 5-6 13-14				1-2	1-2 7-8 13-14 19-20	1-2 3-4 9-10
60-64	1-2 9-10			1-2		1-2 13-14	1-2 5-6 7-8
64-68	5-6 13-14					5-6 13-14	1-2 5-6 9-10
68-72	1-2 5-6				1-2	3-4 5-6 13-14 19-20	1-2 5-6
72-76	1-2 13-14 17-18	1-2				5-6 13-14 17-18	1-2 7-8
76-80	9-10 13-14					9-10 13-14	1-2 11-12 13-14
80-84	1-2 9-10				1-2	3-4 9-10 13-14 19- 20	1-2 11-12 13-14
84-88	1-2 17-18	1-2				5-6 17-18	1-2
88-92	1-2 17-18	1-2				5-6 17-18	3-4 5-6 7-8 9-10
92-96	1-2 7-8 19-20	1-2				5-6 17-18	3-4 5-6 7-8
96-100	1-2 7-8 19-20	1-2				5-6 17-18	3-4 5-6 7-8
100-104	1-2 5-6 17-18		1-2			3-4 7-8 9-10 19-20	3-4 5-6 9-10
104-108	1-2 5-6 17-18		1-2			3-4 7-8 9-10 19-20	3-4 5-6 9-10
108-112	1-2 7-8 15-16	1-2	1-2			9-10 13-14	3-4 5-6 11-12
112-116	1-2 7-8 15-16	1-2	1-2			9-10 13-14	3-4 5-6 11-12
116-120	5-6 17-18			1-2		7-8 9-10 15-16 17- 18	3-4 5-6 11-12
120-124	5-6 17-18			1-2		7-8 9-10 15-16 17- 18	3-4 5-6 13-14
124-128	3-4 9-10 15-16	1-2		1-2	1-2	3-4 5-6 15-16 17-18	3-4 5-6 13-14
128-132	3-4 9-10 15-16	1-2		1-2	1-2	3-4 5-6 15-16 17-18	3-4 7-8
132-136	1-2 7-8 15-16				1-2	3-4 7-8 13-14 19-20	3-4 9-10
136-140	1-2 7-8 15-16				1-2	3-4 7-8 13-14 19-20	3-4 9-10
140-144	3-4 9-10 15-16			1-2	1-2	3-4 13-14 19-20	3-4 11-12

The following connections are common for all the above frequencies

SZ2-SZ3-SZ24-SZ25	SZ1-SZ26	SZ16	SZ27	SZ28-SZ29
1-2	1-3	3-4	3-4	3-4

Band 144 ÷ 248 kHz

kHz	SZ4-SZ23	SZ5 SZ19	SZ6 SZ20	SZ7 SZ21	SZ8 SZ22	SZ9-SZ18	SZ17
144-148	3-4 9-10 15-16			1-2	1-2	3-4 13-14 19-20	3-4 11-12
148-152	5-6 9-10			1-2		7-8 11-12 13-14	3-4
152-156	1-2 7-8 11-12	1-2		1-2	1-2	11-12 13-14 19-20	3-4
156-160	1-2 7-8 11-12 15-16					3-4 7-8 11-12 13-14 19-20	3-4
160-164	1-2 7-8 11-12 15-16					3-4 7-8 11-12 13-14 19-20	3-4
164-168	1-2 7-8 15-16					3-4 7-8 13-14	5-6 7-8 11-12 13-14
168-172	1-2 7-8 15-16					3-4 7-8 13-14	5-6 7-8 11-12 13-14
172-176	1-2 7-8 11-12	1-2		1-2		13-14	5-6 7-8 11-12
176-180	1-2 7-8 11-12	1-2		1-2		13-14	5-6 7-8 11-12
180-184	1-2 7-8 19-20	1-2				17-18	5-6 7-8 13-14
184-188	1-2 7-8 19-20	1-2				17-18	5-6 7-8 11-12
188-192	1-2 7-8 11-12	1-2			1-2	7-8 11-12 15-16 17-18	5-6 7-8 13-14
192-196	1-2 7-8 11-12	1-2			1-2	7-8 11-12 15-16 17-18	5-6 7-8 13-14
196-200	3-4 7-8 9-10 15-16 19-20					3-4 7-8 11-12 15-16 17-18	5-6 7-8 13-14
200-204	3-4 7-8 9-10 15-16 19-20					3-4 7-8 11-12 15-16 17-18	5-6 7-8
204-208	5-6 11-12 19-20					7-8 11-12 17-18	5-6 9-10 11-12
208-212	13-14				1-2	17-18	5-6 9-10 13-14
212-216	13-14				1-2	17-18	5-6 9-10 13-14
216-220	13-14				1-2	17-18	5-6 9-10 13-14
220-224	1-2 7-8 11-12 15-16				1-2	3-4 7-8 11-12 17-18	5-6 9-10
224-228	1-2 7-8 11-12 15-16				1-2	3-4 7-8 11-12 17-18	5-6 9-10
228-232	1-2 7-8 15-16				1-2	3-4 7-8 17-18	5-6 11-12 13-14
232-236	1-2 7-8 15-16				1-2	3-4 7-8 17-18	7-8 9-10 13-14
236-240	1-2	1-2	1-2	1-2	1-2	17-18	7-8 9-10
240-244	1-2	1-2	1-2	1-2	1-2	17-18	5-6 11-12
244-248	1-2	1-2	1-2	1-2	1-2	17-18	5-6 11-12 13-14

The following connections are common for all the above frequencies

SZ2-SZ3-SZ24-SZ25	SZ1-SZ26	SZ16	SZ27	SZ28-SZ29
1-2	1-3	3-4	3-4	3-4

Band 248 ÷ 352 kHz

kHz	SZ4-SZ23	SZ5 SZ19	SZ6 SZ20	SZ7 SZ21	SZ8 SZ22	SZ9-SZ18	SZ17
248-252	1-2 7-8 15-16	1-2			1-2	7-8 13-14 19-20	1-2 5-6 11-12 13-14
252-256	1-2 7-8 15-16	1-2			1-2	7-8 13-14 19-20	1-2 5-6 11-12 13-14
256-260	1-2 7-8 15-16				1-2	3-4 7-8 13-14 19-20	1-2 9-10 11-12 13-14
260-264	1-2 7-8 15-16				1-2	3-4 7-8 13-14 19-20	1-2 9-10 11-12 13-14
264-268	3-4 5-6 15-16				1-2	1-2 7-8 15-16 17-18	1-2 9-10 11-12 13-14
268-272	3-4 5-6 15-16				1-2	1-2 7-8 15-16 17-18	1-2 9-10 11-12 13-14
272-276	3-4 5-6 11-12 15-16 19-20					3-4 7-8 11-12 13-14 17-18	1-2 9-10 11-12
276-280	3-4 5-6 11-12 15-16 19-20					3-4 7-8 11-12 13-14 17-18	1-2 9-10 11-12
280-284	1-2 5-6 9-10			1-2		3-4 7-8 11-12 13-14	1-2 9-10
284-288	1-2 5-6 9-10			1-2		3-4 7-8 11-12 13-14	1-2 9-10
288-292	5-6 9-10			1-2		7-8 11-12 13-14	1-2 9-10
292-296	5-6 9-10			1-2		7-8 11-12 13-14	1-2 9-10
296-300	7-8 13-14 19-20				1-2	5-6 17-18	1-2 11-12
300-304	7-8 13-14 19-20				1-2	5-6 17-18	1-2 11-12
304-308	1-2 7-8 11-12 15-16 19-20					3-4 7-8 11-12 13-14 19-20	1-2 11-12
308-312	1-2 7-8 11-12 15-16 19-20					3-4 7-8 11-12 13-14 19-20	1-2 11-12
312-316	1-2 7-8 11-12 15-16 19-20					3-4 7-8 11-12 13-14 19-20	1-2 11-12
316-320	1-2 7-8 11-12 15-16 19-20					3-4 7-8 11-12 13-14 19-20	1-2 11-12
320-324	1-2 7-8 15-16					3-4 7-8 13-14	3-4 5-6 7-8 9-10
324-328	1-2 7-8 15-16					3-4 7-8 13-14	3-4 5-6 7-8 9-10
328-332	1-2 7-8 15-16					3-4 7-8 13-14	3-4 5-6 7-8 9-10
332-336	1-2 7-8 11-12	1-2		1-2		13-14	3-4 5-6 7-8 11-12
336-340	1-2 7-8 11-12	1-2		1-2		13-14	3-4 5-6 7-8 11-12
340-344	1-2 7-8 11-12	1-2		1-2		13-14	3-4 5-6 7-8 11-12
344-348	5-6		1-2	1-2		14-14	3-4 5-6 7-8 11-12
348-352	5-6		1-2	1-2		13-14	3-4 5-6 7-8 11-12

The following connections are common for all the above frequencies

SZ2-SZ3-SZ24-SZ25	SZ1-SZ26	SZ16	SZ27	SZ28-SZ29
3-4	1-2 3-4	3-4	3-4	3-4

Band 352 ÷ 456 kHz

kHz	SZ4-SZ23	SZ5 SZ19	SZ6 SZ20	SZ7 SZ21	SZ8 SZ22	SZ9-SZ18	SZ17
352-356	5-6		1-2	1-2		13-14	3-4 5-6 7-8 11-12
356-360	9-10 13-14				1-2	11-12 15-16 17-18	3-4 5-6 9-10
360-364	9-10 13-14				1-2	11-12 15-16 17-18	3-4 5-6 9-10
364-368	9-10 13-14				1-2	11-12 15-16 17-18	3-4 5-6 9-10
368-372	1-2 7-8 15-16 19-20				1-2	3-4 7-8 15-16 17-18	3-4 5-6 9-10
372-376	1-2 7-8 15-16 19-20					3-4 7-8 15-16 17-18	3-4 5-6 9-10
376-380	1-2 7-8 15-16 19-20					3-4 7-8 15-16 17-18	3-4 5-6 11-12
380-384	1-2 7-8 15-16 19-20					3-4 7-8 15-16 17-18	3-4 5-6 11-12
384-388	1-2 11-12 19-20					3-4 11-12 17-18	3-4 5-6 11-12
388-392	1-2 11-12 19-20					3-4 11-12 17-18	3-4 5-6 11-12
392-396	1-2 11-12 19-20					3-4 11-12 17-18	3-4 9-10
396-400	1-2 11-12 19-20					3-4 11-12 17-18	3-4 9-10
400-404	1-2 11-12 19-20					3-4 11-12 17-18	3-4 9-10
404-408	1-2 11-12 19-20					3-4 11-12 17-18	3-4 9-10
408-412	1-2 11-12 19-20					3-4 11-12 17-18	3-4 9-10
412-416	1-2 11-12 19-20					3-4 11-12 17-18	3-4 9-10
416-420	1-2 11-12 19-20					3-4 11-12 17-18	3-4 9-10
420-424	13-14				1-2	17-18	3-4 9-10
424-428	13-14				1-2	17-18	3-4 9-10
428-432	13-14				1-2	17-18	3-4 9-10
432-436	13-14				1-2	17-18	3-4 9-10
436-440	13-14				1-2	17-18	3-4 9-10
440-444	13-14				1-2	17-18	3-4 9-10
444-448	13-14				1-2	17-18	5-6 7-8 9-10 11-12
448-452	1-2 7-8 15-16				1-2	3-4 7-8 17-18	5-6 7-8 9-10
452-456	1-2 7-8 15-16				1-2	3-4 7-8 17-18	5-6 7-8 9-10

The following connections are common for all the above frequencies

SZ2-SZ3-SZ24-SZ25	SZ1-SZ26	SZ16	SZ27	SZ28-SZ29
3-4	1-2 3-4	3-4	3-4	3-4

Band 456 ÷ 472 kHz

kHz	SZ4-SZ23	SZ5 SZ19	SZ6 SZ20	SZ7 SZ21	SZ8 SZ22	SZ9-SZ18	SZ17
456-460	1-2 7-8 15-16				1-2	3-4 7-8 17-18	5-6 7-8 9-10
460-464	1-2 7-8 15-16				1-2	3-4 7-8 17-18	5-6 7-8 9-10
464-468	1-2 7-8 15-16				1-2	3-4 7-8 17-18	5-6 7-8 9-10
468-472	1-2 7-8 15-16				1-2	3-4 7-8 17-18	5-6 7-8 9-10

The following connections are common for all the above frequencies

SZ2-SZ3-SZ24-SZ25	SZ1-SZ26	SZ16	SZ27	SZ28-SZ29
3-4	1-2 3-4	3-4	3-4	3-4

Band 472 ÷ 500 kHz

kHz	SZ4-SZ23	SZ5 SZ19	SZ6 SZ20	SZ7 SZ21	SZ8 SZ22	SZ9-SZ18	SZ17
472-476	1-2	1-2	1-2	1-2	1-2	17-18	5-6 7-8 13-14
476-480	1-2	1-2	1-2	1-2	1-2	17-18	5-6 7-8 13-14
480-484	1-2	1-2	1-2	1-2	1-2	17-18	5-6 7-8 13-14
484-488	1-2	1-2	1-2	1-2	1-2	17-18	5-6 7-8 13-14
488-492	1-2	1-2	1-2	1-2	1-2	17-18	5-6 7-8 13-14
492-496	1-2	1-2	1-2	1-2	1-2	17-18	5-6 7-8 13-14
496-500	1-2	1-2	1-2	1-2	1-2	17-18	5-6 7-8 13-14

The following connections are common for all the above frequencies

SZ2-SZ3-SZ24-SZ25	SZ1-SZ26	SZ16	SZ27	SZ28-SZ29
3-4	1-2 3-4	1-2	3-4	3-4

TABLE 14 – INTX SINGLE CHANNEL JUMPERS

2.10.2.3 Transmission filter tuning

Required instruments

- Signal generator W&G PS 30 or equivalent
- Selective voltmeter W&G SPM 30 or equivalent
- 75 ohm dummy load

Frequency pre-set

Program the TX filter for the PLC bandwidth, according to the programming tables.

**Set the unit for single power amplifier
(SZ-15 jumpers 1-2 closed 3-4 open)**

Test bench

Arrange the bench test according the following figure

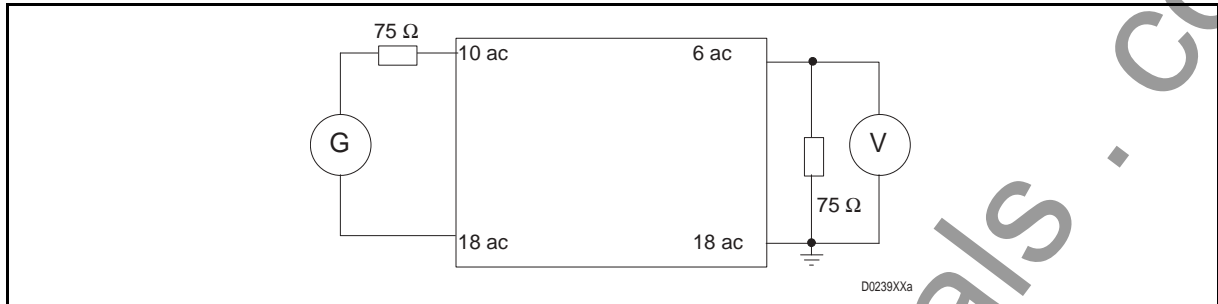

FIGURE 16 – TX FILTER TUNING TEST RIG

Filter test for single channel application

FREQUENCY response and in-band loss

Send a test tone at frequency $F_x = F_c + 2 \text{ kHz}$, level 0 dBV. (F_c = Carrier Frequency)

Adjust the two coil for the minimum signal loss. Verify that the filter loss match the value on table 15 – Single channel filter maximum loss.

FREQUENCY kHz		$F_x = F_c + 2 \text{ kHz}$
MIN.	MAX.	Loss dB
40	104	≤ 0.5
104	304	≤ 1.5
304	396	≤ 2.0
396	496	≤ 2.2

TABLE 15 – SINGLE CHANNEL FILTER MAXIMUM LOSS

Adjust the two coils and check that the filter frequency response match the mask on figure 17 – Frequency Loss mask for $F_c \leq 392 \text{ kHz}$ - or figure 18 – Frequency Loss mask for $F_c \geq 396 \text{ kHz}$ -.

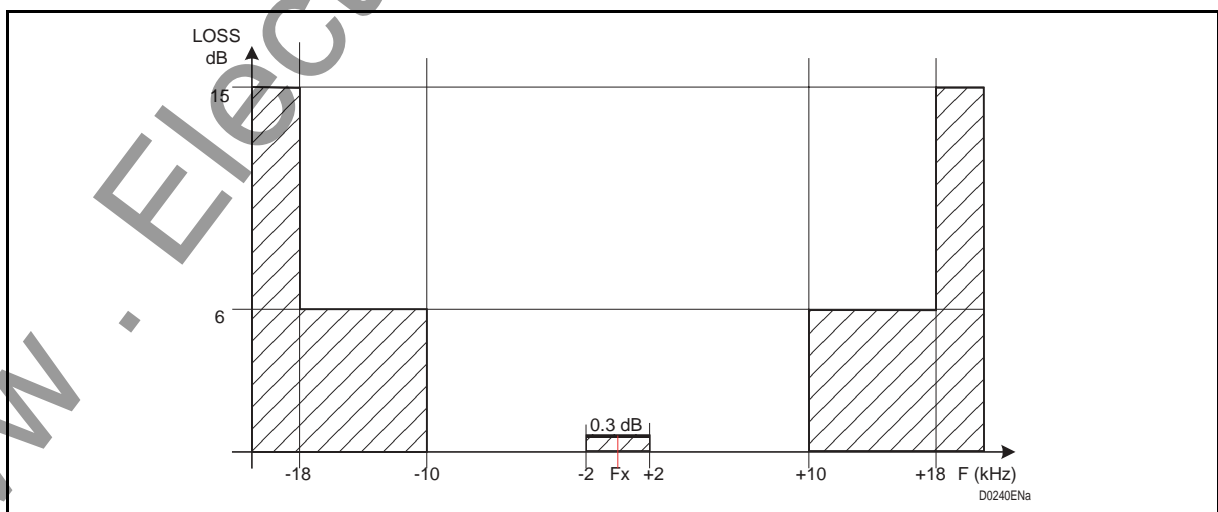

FIGURE 17 – FREQUENCY LOSS MASK FOR $F_c \leq 392 \text{ KHZ}$ -

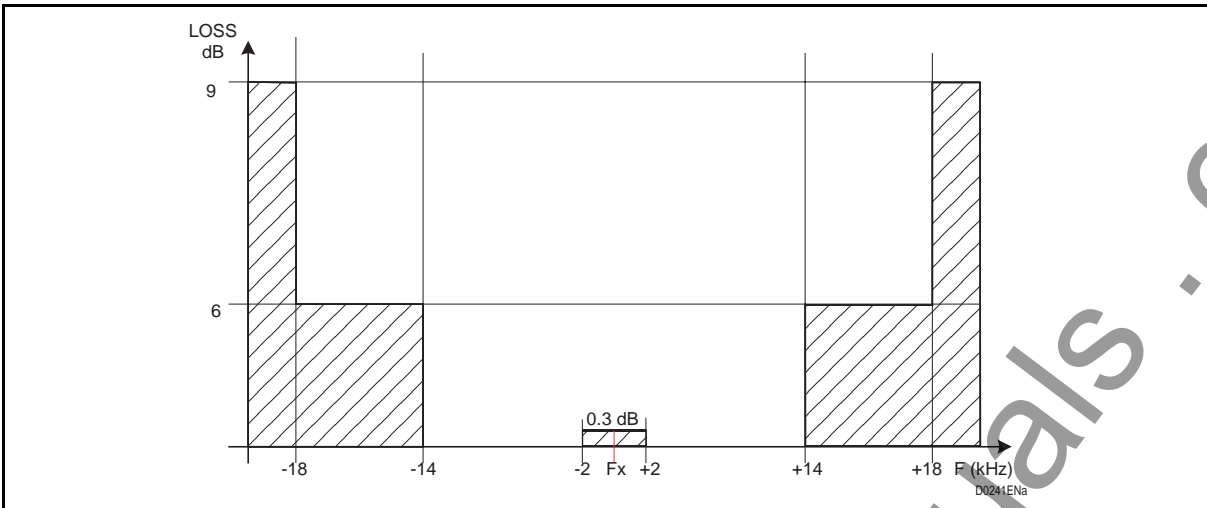

FIGURE 18 – FREQUENCY LOSS MASK FOR FC ≥ 396 KHZ-

Tapping loss test

Arrange the test bench in figure 19 – Tapping loss test RIG.

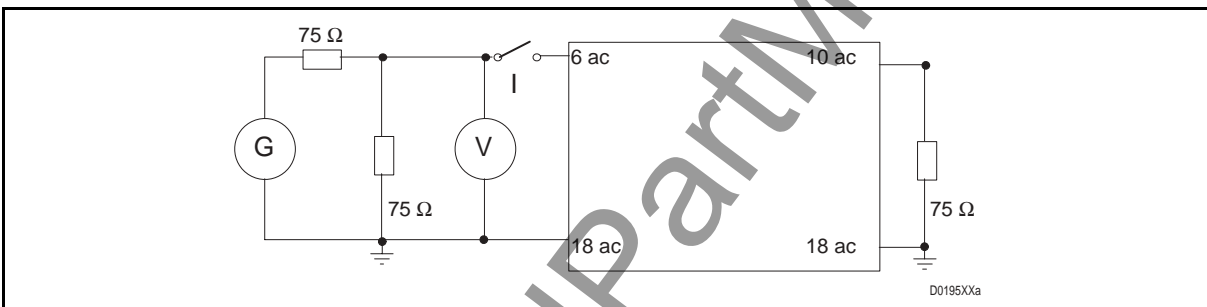

FIGURE 19 – TAPPING LOSS TEST RIG

Proceed as follow:

- Open switch I;
- Send a test tone at Fx frequency, 0 dBv level. Verify the level read by the voltmeter is 0 dBv;
- Close switch I;
- Verify that at the frequency on table 16 – Tapping loss limits the filter do not load.

FREQUENCY kHz		Fx -10 kHz	Fx +10 kHz
MIN.	MAX.		
40	392	≤ 0.8	≤ 0.8
396	500	≤ 1.4	≤ 1.4

TABLE 16 – TAPPING LOSS LIMITS

NOTE: Completed the filter tuning procedures, set the filter input SZ15 according to your PLC HF power.

Filter test for double channel application

FREQUENCY response and in-band loss

Send a test tone at frequency $F_x = F_c$, level 0 dBv. (F_c = Carrier Frequency)

Adjust the two coils for the minimum signal loss. Verify that the filter loss match the value on table 17 – Maximum loss for double channel filter.

FREQUENCY kHz		Fx
MIN.	MAX.	Loss dB
40	96	≤ 0.5
104	296	≤ 1.5
304	392	≤ 2.0
400	500	≤ 2.2

TABLE 17 – MAXIMUM LOSS FOR DOUBLE CHANNEL FILTER

Adjust the two coils and check that the filter frequency response match the mask on figure 20 – Frequency / loss mask for $FC \leq 392$ kHz or figure 21 – Frequency loss mask for $FC \geq 400$ kHz.

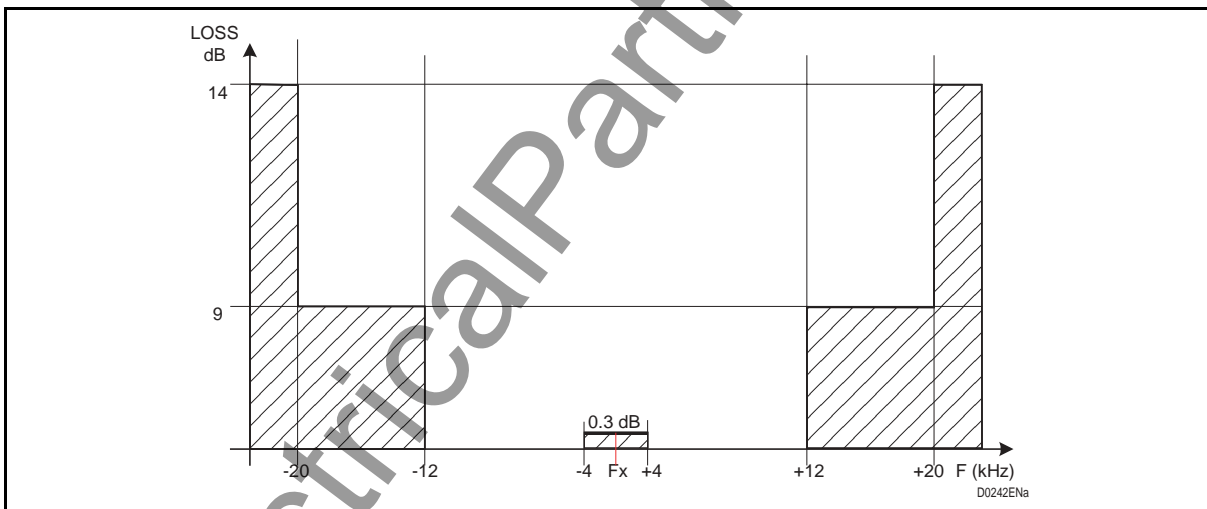

FIGURE 20 – FREQUENCY / LOSS MASK FOR $FC \leq 392$ KHZ

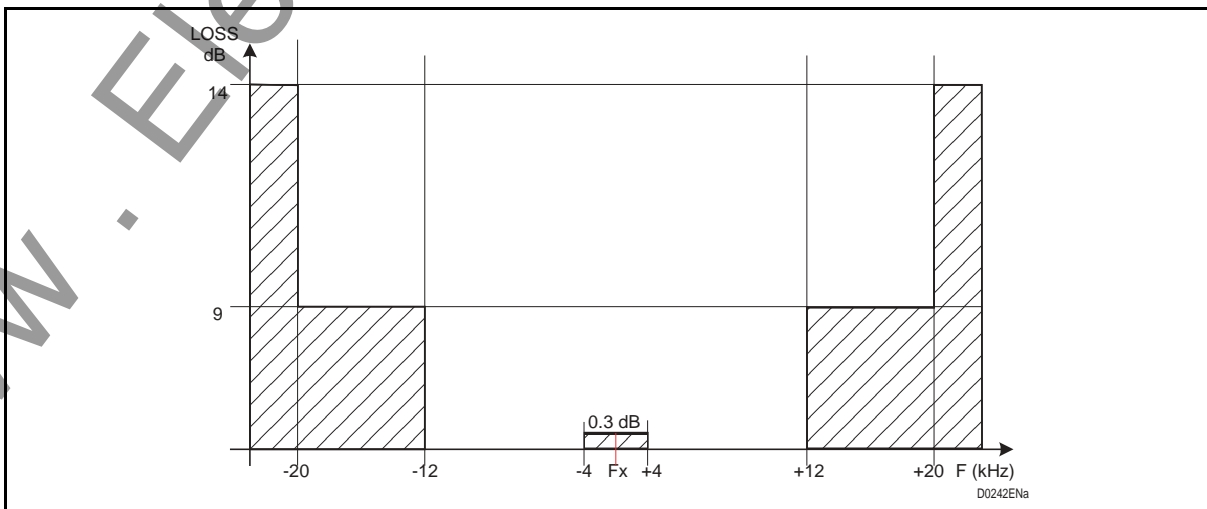

FIGURE 21 – FREQUENCY LOSS MASK FOR $FC \geq 400$ KHZ

Tapping loss test

Arrange the test bench as per figure 19 – Tapping loss test RIG

Proceed as follow:

- Open switch I;
- Send a test tone at Fx frequency, 0 dBv level. Verify the level read by the voltmeter is 0 dBv;
- Close switch I;
- Verify that at the frequency on table 16 – Tapping loss limits the filter do not load.

FREQUENCY kHz		Fx -12 kHz	Fx +12 kHz
MIN.	MAX.		
40	392	≤ 0.8	≤ 0.8
396	500	≤ 1.4	≤ 1.4

TABLE 18 – TAPPING LOSS LIMITS DOUBLE CHANNEL FILTER

NOTE: Completed the filter tuning procedures, set the filter input SZ15 according to your PLC HF power.

2.11 Reception Line Interface (INRX)

2.11.1 Pre-setting

Verify and pre-set the card according to the field request:

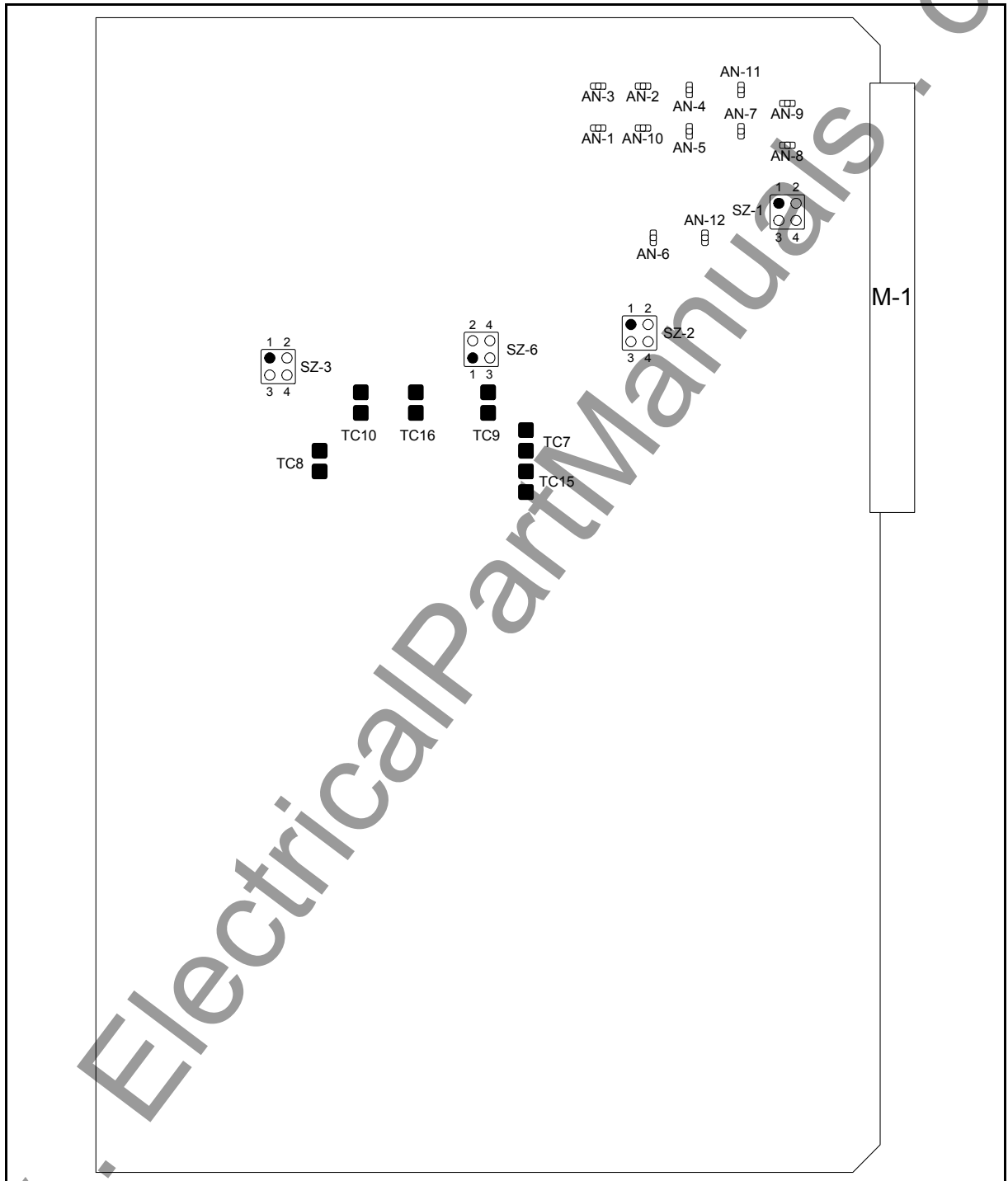

FIGURE 22 – INRX JUMPERS TO HF LINK CONNECTION

2.11.2 HF Line impedance programming

OPERATION	DIAGRAM Reference	CONNECTIONS	
		CLOSED	OPEN
HF output balanced	AN8-AN9		X
HF output unbalanced	AN8-AN9	X	
75 ohm •HF impedance (only unbalanced) (standard)	AN2-AN10	X	
	AN1-AN3		X
	AN4-AN11		X
	AN5-AN7		X
	AN6-AN12		X
150 ohm • HF impedance (balanced or unbalanced)	AN1-AN3	X	
	AN4-AN11	X	
	AN2-AN1		X
	AN5-AN7		X
	AN6-AN12		X
125 ohm • HF impedance (balanced or unbalanced)	AN1-AN3	X	
	AN5-AN7	X	
	AN2-AN10		X
	AN4-AN11		X
	AN6-AN12		X
50 ohm •HF impedance (only unbalanced)	AN1-AN3	X	
	AN6-AN12	X	
	AN2-AN10		X
	AN5-AN7		X
	AN4-AN11		X
2 Wire HF line	SZ1	1-2	3-4
	SZ2		1-2 3-4
	SZ3	1-2	3-4
	SZ6	1-2	3-4
4 Wire HF line	SZ1	1-3	2-4
	SZ2	2-4	1-3
	SZ3		ALL OPEN
	SZ6		ALL OPEN
RX attenuator 3 dB included	TC8		X
	TC10	X	
RX attenuator 3 dB excluded	TC8	X	
	TC10		X
RX attenuator 6 dB included	TC15		X
	TC16	X	

OPERATION	DIAGRAM Reference	CONNECTIONS	
		CLOSED	OPEN
RX attenuator 6 dB excluded	TC15		X
	TC16	X	
RX attenuator 9 dB included	TC7		X
	TC9	X	
RX attenuator 9 dB excluded	TC7	X	
	TC9		X

TABLE 19 – INRX HF OUTPUT SET-UP

Recommended CONFIGURATION for RX attenuator

OPERATION	DIAGRAM REFERENCE	CONNECTIONS	
		CLOSED	OPEN
6 dB Attenuator Single Channel PLC 10 W or Double Channel PLC 10/20/40 W	TC8	x	
	TC10		x
	TC15		x
	TC16	x	
9 dB Attenuator Single Channel PLC 20 W	TC7	x	
	TC9		x
	TC8		x
	TC10	x	
12 dB Attenuator Single Channel PLC 40 W	TC15		x
	TC16	x	
	TC7		x
	TC9	x	

TABLE 20 – INRX INPUT ATTENUATOR

2.11.3 Programming tables from 40 to 500 KHZ

NOTE:

The following table shows the entire filter programming for either single or double channel bandwidth.

Beware, only the closed TC's are indicated. All the other ones are to be intended open, out of the TC indicated on table 19 – INRX HF output set-up.

The PLC reception filter can be tuned at any 1 kHz step, between 40 and 496 kHz, using the same JUMPERs of the closest standard reception channel.

The TC figures are clearly printed on the PCB.

SINGLE CHANNEL kHz	DOUBLE CHANNEL kHz	DIAGRAM REFERENCE (TC CLOSED)
40 – 44	40 - 48	24,25,26,27,20,21,22,23,46,47,48,49,147,148,174,175,143,144,145,146,170,171,172,173,55,56,52,54,79,81,116,117,113,115,140,142,86,87,88,82,83,84,107,108,109,13,160,18,73,134
44 – 48		24,25,27,21,22,47,48,20,45,37,147,148,175,144,145,171,172,143,148,169,55,56,51,76,66,116,117,112,137,127,86,87,83,84,108,109,82,106,89,13,160,18,73,134
48 – 52	48 - 56	24,26,27,20,46,147,174,175,143,170,55,51,52,78,79,116,112,113,139,140,86,88,82,107,83,101,97,13,160,18,73,134
52 – 56		24,27,21,22,47,48,147,175,144,145,171,172,55,51,54,78,81,116,112,115,139,142,86,82,84,107,109,7,8,15,13,160,18,73,134
56 – 60	56 64	24,20,42,40,39,35,34,37,147,143,166,162,161,156,155,158,55,52,54,79,81,51,75,65,116,113,115,140,142,112,136,126,86,82,103,95,109,13,160,18,73,134
60 64		25,26,27,21,40,35,49,148,174,175,144,162,156,173,55,72,79,116,113,140,87,88,82,107,13,160,18,73,134
64 – 68	64 - 72	13,18,22,25,26,33,37,40,41,53,55,73,80,82,84,85,87,107,109,110,114,116,134,141,145,148,154,158,160,162,165,174
68 – 72		25,27,23,49,20,44,36,148,175,146,173,143,168,157,56,51,52,53,54,78,79,80,81,117,112,113,114,115,139,140,141,142,87,83,84,108,109,13,160,18,73,134
72 – 76	72 - 80	25,21,23,47,49,20,44,36,148,144,146,171,173,143,168,157,56,51,52,54,78,79,81,117,112,113,115,139,140,142,87,83,108,13,160,18,73,134
76 – 80		25,20,45,37,21,40,36,148,143,169,158,144,162,157,56,51,52,78,79,117,112,113,139,140,87,82,105,95,94,102,110,13,160,18,73,134
80 - 84	80 - 88	26,27,21,23,47,49,20,44,36,174,175,144,146,171,143,168,157,56,51,53,78,80,52,71,66,117,112,114,139,141,113,132,127,88,82,83,107,108,13,160,18,73,134
84 - 88		26,27,23,49,20,42,38,174,175,146,173,143,166,159,56,51,78,52,70,65,117,112,139,113,131,126,88,83,84,108,109,13,160,18,73,134
88 - 92	88 - 96	26,27,20,42,34,35,39,49,174,175,143,166,155,156,161,173,56,51,78,52,70,64,81,112,139,113,131,125,142,117,88,83,108,82,106,98,13,160,18,73,134
92 - 96		26,21,22,47,48,20,45,37,174,144,145,171,172,143,169,158,56,52,53,54,79,80,81,117,113,114,115,140,141,142,88,85,110,83,101,97,13,160,18,73,134

SINGLE CHANNEL kHz	DOUBLE CHANNEL kHz	DIAGRAM REFERENCE (TC CLOSED)
96 - 100	96 - 104	26,20,46,22,39,37,143,170,145,161,158,174,56,52,54,79,81,51,75,65,117,113,115,140,142,112,136,126,88,82,103,101,95,97,13,160,18,73,134
100 - 104		26,23,49,21,40,36,174,146,173,144,162,157,56,53,54,80,81,51,72,67,117,114,115,141,142,112,133,128,88,85,106,103,93,90,13,160,18,73,134
104 - 108	104 - 112	26,22,44,42,32,29,174,145,168,166,153,150,56,52,54,79,81,117,113,115,140,142,88,82,105,96,110,13,160,18,73,134
108 - 112		27,20,21,46,47,22,39,37,175,143,144,171,145,161,158,170,56,52,79,117,113,140,88,13,160,18,73,134
112 - 116	112 - 120	27,20,21,46,47,175,143,144,170,171,56,51,54,76,72,70,63,65,117,112,115,137,133,131,124,126,82,85,107,110,83,101,97,13,160,18,73,134
116 - 120		27,20,46,23,49,175,143,146,170,173,56,52,72,75,76,60,57,58,117,113,133,136,137,121,118,119,83,84,108,109,82,106,98,13,160,18,73,134
120 - 124	120 - 128	27,21,23,47,49,175,144,146,171,173,56,54,81,52,70,65,117,115,142,113,131,126,82,84,107,109,13,160,18,73,134
124 - 128		27,22,48,20,42,38,175,145,172,143,166,159,56,53,75,72,76,61,57,66,117,114,133,136,137,118,122,127,82,85,107,110,13,160,18,73,134
128 - 132	128 - 136	27,23,49,20,44,36,175,146,173,143,168,157,56,52,70,65,117,113,131,126,83,84,108,109,13,160,18,73,134
132 - 136		27,20,22,44,42,41,33,37,175,143,145,168,166,165,154,158,56,52,71,66,117,113,132,127,82,107,83,102,98,13,160,18,73,134
136 - 140	136 - 144	27,20,44,39,35,37,175,143,168,161,156,158,56,51,72,63,68,66,117,112,133,124,129,127,82,107,83,101,96,110,13,160,18,73,134
140 - 144		27,23,45,42,32,29,175,146,169,166,153,150,56,117,83,108,82,105,97,13,160,18,73,134
144 - 148	144 - 152	27,20,45,34,40,48,33,175,143,169,155,162,172,154,51,52,53,78,79,80,112,113,114,139,140,141,83,108,82,106,98,13,160,18,73,134
148 - 152		20,22,23,46,48,49,143,145,146,170,172,173,51,52,53,78,79,80,112,113,114,139,140,141,83,108,84,100,98,13,160,18,73,134
152 - 156	152 - 160	27,175,51,52,53,78,79,80,112,113,114,139,140,141,82,107,13,160,18,73,134
156 - 160		21,22,23,47,48,49,144,145,146,171,172,173,51,52,54,78,79,81,112,113,115,139,140,142,85,110,82,103,99,13,160,18,73,134
160 - 164	160 - 168	20,21,46,47,143,144,170,171,51,52,54,78,79,81,112,113,115,139,140,142,85,110,82,105,97,13,160,18,73,134
164 - 168		26,27,20,46,174,175,143,170,55,56,52,53,79,80,116,117,113,114,141,88,83,84,108,109,11,12,164,163,17,19,77,138,69,130
168 - 172	168 - 176	26,27,20,44,36,21,41,37,174,175,143,168,157,144,165,158,55,56,52,79,51,76,66,116,117,113,140,112,137,127,88,82,107,83,102,98,11,12,164,163,17,19,77,138,69,130
172 - 176		26,27,23,45,42,32,29,174,175,146,169,166,153,150,55,56,54,81,51,72,67,116,117,115,142,112,133,128,88,83,108,82,105,97,11,12,164,163,17,19,77,138,69,130

SINGLE CHANNEL kHz	DOUBLE CHANNEL kHz	DIAGRAM REFERENCE (TC CLOSED)
176 - 180	176 - 184	26,20,21,46,47,22,39,37,174,143,144,170,171,145,161,158,55,56,54,81,51,75,65,116,117,115,142,112,136,126,88,82,107,11,12,164,163,17,19,77,138,69,130
180 - 184		26,20,21,46,47,174,143,144,170,171,55,56,51,75,65,116,117,112,136,126,88,84,109,82,103,94,110,11,12,164,163,17,19,77,138,69,130
184 - 188	184 - 192	26,20,23,46,49,174,143,146,170,173,55,56,52,70,64,81,116,117,113,131,125,142,88,82,85,106,103,101,95,97,11,12,164,163,17,19,77,138,69,130
188 - 192		26,20,46,21,41,37,174,143,170,144,165,158,55,56,116,117,88,84,109,11,12,164,163,17,19,77,138,69,130
192 - 196	192 - 200	26,22,48,20,42,38,174,145,172,143,166,159,55,51,52,53,78,79,80,116,112,113,114,139,140,141,88,82,105,96,100,97,11,12,164,163,17,19,77,138,69,130
196 - 200		26,23,49,20,44,36,174,146,173,143,168,157,55,51,52,78,79,53,68,66,116,112,113,139,140,114,129,127,82,83,84,107,108,109,11,12,164,163,17,19,77,138,69,130
200 - 204	200 - 208	26,20,32,42,44,35,39,37,174,143,153,166,169,156,161,158,55,51,52,78,79,116,112,113,139,140,88,82,103,94,96,100,110,11,12,164,163,17,19,77,138,69,130
204 - 208		26,21,42,31,44,48,174,144,166,152,168,172,55,51,53,54,78,80,81,116,112,114,115,139,141,142,88,82,103,94,110,11,12,164,163,17,19,77,138,69,130
208 - 212	208 - 216	26,21,40,36,174,144,162,157,55,51,54,78,81,52,70,65,116,112,115,139,142,113,131,126,82,84,85,107,109,110,11,12,164,163,17,19,77,138,69,130
212 - 216		27,20,22,23,46,48,49,175,143,145,170,172,173,146,55,51,78,52,70,65,116,112,139,113,131,126,88,11,12,164,163,17,19,77,138,69,130
216 - 220	216 - 224	26,174,55,51,78,52,71,66,116,112,139,113,132,127,82,84,107,109,83,102,98,11,12,164,163,17,19,77,138,69,130
220 - 224		27,20,21,46,47,175,143,144,170,171,55,51,78,116,112,139,82,85,107,110,83,101,97,11,12,164,163,17,19,77,138,69,130
224 - 228	224 - 232	27,21,23,47,49,20,44,36,175,144,146,171,173,143,168,157,55,52,53,54,79,80,81,116,113,114,115,140,141,142,82,83,107,108,11,12,164,163,17,19,77,138,69,130
228 - 232		27,20,23,46,49,175,143,146,170,173,55,52,53,79,80,51,76,66,116,113,114,140,141,112,137,127,83,84,108,109,82,106,98,11,12,164,163,17,19,77,138,69,130
232 - 236	232 - 240	27,21,22,47,48,175,144,145,171,172,55,52,53,79,80,116,113,114,140,141,83,85,108,110,82,105,97,11,12,164,163,17,19,77,138,69,130
236 - 240		27,37,41,21,46,175,143,144,170,165,158,65,55,52,79,51,75,116,113,140,112,136,126,82,107,84,109,11,12,164,163,17,19,77,138,69,130
240 - 244	240 - 248	27,20,46,21,40,35,49,175,143,170,144,162,156,173,55,52,54,79,81,116,113,115,140,142,84,85,109,110,82,103,99,11,12,164,163,17,19,77,138,69,130

SINGLE CHANNEL kHz	DOUBLE CHANNEL kHz	DIAGRAM REFERENCE (TC CLOSED)
244 - 248		27,22,48,20,42,38,175,145,172,143,166,159,55,52,79,51,75,64,81,116,113,140,112,136,125,142,55,52,79,51,75,64,81,116,113,140,112,136,125,142,11,12,164,163,17,19,77,138,69,130
248 - 252	248 - 256	27,20,46,175,143,170,55,52,79,116,113,140,83,84,108,109,11,12,164,163,17,19,77,138,69,130
252 - 256		27,23,49,20,44,36,175,146,173,143,168,157,55,51,72,67,53,68,66,116,112,133,128,114,129,127,83,84,108,109,11,12,164,163,17,19,77,138,69,130
256 - 260	256 - 264	27,21,47,175,144,171,55,52,72,75,60,58,116,113,133,136,121,119,82,107,83,101,97,11,12,164,163,17,19,77,138,69,130
260 - 264		27,20,23,45,42,40,34,36,175,143,146,169,166,162,155,157,55,54,81,52,70,65,116,115,142,113,131,126,82,107,83,101,97,11,12,164,163,17,19,77,138,69,130
264 - 268	264 - 272	27,22,48,175,145,172,55,53,80,116,114,141,82,107,83,102,98,11,12,164,163,17,19,77,138,69,130
268 - 272		27,21,42,44,45,31,28,37,175,144,166,168,169,149,152,158,55,51,72,63,64,68,81,116,112,133,124,125,129,142,82,107,83,101,96,110,11,12,164,163,17,19,77,138,69,130
272 - 276	272 - 280	27,22,42,44,45,32,28,29,175,145,166,168,169,149,153,150,55,54,76,75,72,60,61,58,116,115,137,136,133,121,122,119,82,107,83,101,96,110,11,12,164,163,17,19,77,138,69,130
276 - 280		20,21,22,46,47,48,143,144,145,170,171,172,55,51,72,63,68,66,116,112,133,124,129,127,83,108,82,105,97,11,12,164,163,17,19,77,38,69,130
280 - 284	280 - 288	27,21,40,36,175,144,162,157,56,51,52,53,54,78,79,80,81,117,112,113,114,115,139,140,141,142,83,108,82,105,97,11,12,164,163,17,19,77,138,69,130
284 - 288		27,21,40,31,28,45,49,175,144,162,152,149,169,173,55,116,84,85,109,110,11,12,164,163,17,19,77,138,69,130
288 - 292	288 - 296	27,20,44,35,49,175,143,168,156,173,56,51,52,53,78,79,80,117,112,113,114,139,140,141,84,109,82,103,99,11,12,164,163,17,19,77,138,69,130
292 - 296		20,22,23,46,48,49,143,145,146,170,172,173,56,51,52,53,78,79,80,117,112,113,114,139,140,141,84,109,82,103,99,11,12,164,163,17,19,77,138,69,130
296 - 300	296 - 304	20,21,46,47,22,39,37,143,144,170,171,145,161,158,56,51,52,54,78,79,81,117,112,113,115,139,140,142,82,107,11,12,164,163,17,19,77,138,69,130
300 - 304		27,175,56,51,52,54,78,79,81,117,112,113,115,139,140,142,82,107,11,12,164,163,17,19,77,138,69,130
304 - 308	304 - 312	20,22,46,48,21,41,37,143,145,170,172,144,165,158,56,51,52,78,79,53,68,66,117,112,113,139,140,114,129,127,84,109,82,106,98,11,12,164,163,17,19,77,138,69,130
308 - 312		21,22,23,47,48,49,144,145,146,171,172,173,56,51,52,78,79,117,112,113,139,140,85,110,82,103,99,11,12,164,163,17,19,77,138,69,130
312 - 316	312 - 320	20,23,46,49,21,40,36,143,146,170,173,144,162,157,56,51,52,78,79,117,112,113,139,140,84,109,83,102,98,11,12,164,163,17,19,77,138,69,130

SINGLE CHANNEL kHz	DOUBLE CHANNEL kHz	DIAGRAM REFERENCE (TC CLOSED)
316 - 320		20,21,46,47,143,144,170,171,56,51,52,78,79,117,112,113,139,140,85,110,82,105,97,11,12,164,163,17,19,77,138,69,130
320 - 324	320 - 328	20,21,46,47,143,144,170,171,56,51,53,54,78,80,81,117,112,114,115,139,141,142,84,109,82,103,94,110,11,12,164,163,17,19,77,138,69,130
324 - 328		21,22,47,48,20,45,37,144,145,171,172,143,169,158,56,51,53,54,78,80,81,117,112,114,115,139,141,142,84,109,82,103,94,110,11,12,164,163,17,19,77,138,69,130
328 - 332	328 - 336	21,23,47,49,20,44,36,144,146,171,173,143,168,157,56,51,53,78,80,52,71,66,117,112,114,139,141,113,132,127,83,108,11,12,164,163,17,19,77,138,69,130
332 - 336		20,22,46,48,143,145,170,172,56,51,54,78,81,52,70,65,117,112,115,139,142,113,131,126,83,10,811,12,164,163,17,19,77,138,69,130
336 - 340	336 - 344	22,23,48,49,20,42,38,145,146,172,173,143,166,159,56,51,53,78,80,117,112,114,139,141,83,108,11,12,164,163,17,19,77,138,69,130
340 - 344		22,23,48,49,20,42,38,145,146,172,173,143,166,159,56,51,53,78,80,117,112,114,139,141,83,108,11,12,164,163,17,19,77,138,69,130
344 - 348	344 - 352	20,23,46,49,143,146,170,173,56,51,78,52,70,65,117,112,139,113,131,126,85,110,82,103,95,109,11,12,164,163,17,19,77,138,69,130
348 - 352		21,22,47,48,144,145,171,172,56,51,78,52,70,65,117,112,139,113,131,126,82,85,106,103,101,95,97,11,12,164,163,17,19,77,138,69,130
352 - 356	352 - 360	21,22,47,48,144,145,171,172,51,54,56,78,81,112,115,117,139,142,82,89,95,99,100,101,106,11,12,164,163,17,19,77,138,69,130
356 - 360		21,22,47,48,144,145,171,172,56,51,60,66,68,78,117,112,121,127,129,139,83,93,103,105,96,100,98,11,12,164,163,17,19,77,138,69,130
360 - 364	360 - 368	21,22,47,48,144,145,171,172,56,51,78,52,70,64,81,117,112,139,113,131,125,142,82,93,103,105,100,96,98,11,12,164,163,17,19,77,138,69,130
364 - 368		20,46,21,40,36,143,170,144,162,157,56,51,78,117,112,139,82,106,98,83,101,97,11,12,164,163,17,19,77,138,69,130
368 - 372	368 - 376	20,46,21,41,37,143,170,144,165,158,56,51,78,117,112,39,82,103,101,100,96,95,99,11,12,164,163,17,19,77,138,69,130
372 - 376		20,46,21,41,37,143,170,144,165,158,56,51,78,117,112,139,84,109,11,12,164,163,17,19,77,138,69,130
376 - 380	376 - 384	21,23,47,49,144,146,171,173,56,52,53,54,79,80,81,117,113,114,115,140,141,142,84,109,11,12,164,163,17,19,77,138,69,130
380 - 384		20,46,21,40,35,49,143,170,144,162,156,173,56,52,53,54,79,80,81,117,113,114,115,140,141,142,82,103,101,95,97,11,12,164,163,17,19,77,138,69,130
384 - 388	384 - 392	20,46,21,40,35,49,143,170,144,162,156,173,56,52,53,54,79,80,81,117,113,114,115,140,141,142,82,103,101,95,97,11,12,164,163,17,19,77,138,69,130

SINGLE CHANNEL kHz	DOUBLE CHANNEL kHz	DIAGRAM REFERENCE (TC CLOSED)
388 - 392		21,47,20,44,36,144,171,143,168,157,56,52,54,79,81,51,75,65,117,113,115,140,142,112,136,126,82,103,101,95,97,11,12,164,163,17,19,77,138,69,130
392 - 396	392 - 400	21,47,20,44,36,144,171,143,168,157,56,52,54,79,81,51,75,65,117,113,115,140,142,112,136,126,82,103,101,95,97,11,12,164,163,17,19,77,138,69,130
396 - 400		22,23,48,49,145,146,172,173,56,52,53,79,80,117,113,114,140,141,83,103,105,106,92,89,90,11,12,164,163,17,19,77,138,69,130
400 - 404	400 - 408	22,23,48,49,145,146,172,173,56,52,53,79,80,117,113,114,140,141,82,105,100,96,98,11,12,164,163,17,19,77,138,69,130
404 - 408		22,48,20,42,38,145,172,143,166,159,56,52,53,79,80,117,113,114,140,141,82,105,100,96,98,11,12,164,163,17,19,77,138,69,130
408 - 412	408 - 416	22,48,20,42,38,145,172,143,166,159,56,53,54,80,81,51,72,67,117,114,115,141,142,112,133,128,82,105,100,96,98,11,12,164,163,17,19,77,138,69,130
412 - 416		22,48,20,42,38,145,172,143,166,159,56,52,79,51,75,65,117,113,140,112,136,126,83,103,105,92,90,11,12,164,163,17,19,77,138,69,130
416 - 420	416 - 424	20,46,143,170,56,52,54,79,81,117,113,115,140,142,83,103,106,89,90,11,12,164,163,17,19,77,138,69,130
420 - 424		20,46,143,170,56,52,54,79,81,117,113,115,140,142,85,110,11,12,164,163,17,19,77,138,69,130
424 - 428	424 - 432	20,46,143,170,56,52,79,51,76,66,117,113,140,112,137,127,84,103,105,106,93,89,90,11,12,164,163,17,19,77,138,69,130
428 - 432		22,48,20,45,37,145,172,143,169,158,56,52,79,53,68,66,117,113,140,114,129,127,84,105,103,93,90,11,12,164,163,17,19,77,138,69,130
432 - 436	432 - 440	22,48,20,45,37,145,172,143,169,158,56,53,54,80,81,117,114,141,115,142,84,105,103,93,90,11,12,164,163,17,19,77,138,69,130
436 - 440		23,49,20,42,38,146,173,143,166,159,56,52,79,51,75,64,81,117,113,140,112,136,125,142,84,105,103,93,90,11,12,164,163,17,19,77,138,69,130
440 - 444	440 - 448	22,48,21,41,37,145,172,144,165,158,56,52,79,117,113,140,83,101,100,96,98,11,12,164,163,17,19,77,138,69,130
444 - 448		23,49,20,44,36,146,173,143,168,157,56,52,79,117,113,140,84,105,106,89,90,11,12,164,163,17,19,77,138,69,130
448 - 452	448 - 456	23,49,20,44,36,146,173,143,168,157,56,51,72,70,68,63,64,66,117,112,133,131,129,124,125,127,84,105,106,89,90,11,12,164,163,17,19,77,138,69,130
452 - 456		22,48,20,42,33,49,145,172,143,166,154,173,56,54,81,51,72,67,117,115,142,112,133,128,84,101,102,94,98,11,12,164,163,17,19,77,138,69,130
456 - 460	456 - 464	22,48,20,42,33,49,145,172,143,166,154,173,51,72,63,80,56,117,112,133,124,141,84,101,102,94,98,11,12,164,163,17,19,77,138,69,130
460 - 464		23,49,21,40,36,146,173,144,162,157,56,51,72,67,53,68,66,117,112,133,128,114,129,127,84,101,102,94,98,11,12,164,163,17,19,77,138,69,130

SINGLE CHANNEL kHz	DOUBLE CHANNEL kHz	DIAGRAM REFERENCE (TC CLOSED)
464 - 468	464 - 472	21,47,144,171,56,51,72,62,81,117,112,133,123,142,85,106,103,93,90,11,12,164,163,17,19,77,138,69,130
468 - 472		21,47,144,171,56,51,72,62,81,117,112,133,123,142,85,106,103,93,90,11,12,164,163,17,19,77,138,69,130
472 - 476	472 - 480	21,47,144,171,56,53,80,51,76,66,117,112,133,123,142,85,106,103,93,90,11,12,164,163,17,19,77,138,69,130
476 - 480		21,47,144,171,56,53,80,51,72,62,81,117,114,141,112,133,123,142,85,106,105,92,90,11,12,164,163,17,19,77,138,69,130
480 - 484	480 - 488	21,47,144,171,56,81,51,75,65,54,117,115,142,112,136,126,85,106,105,92,90,11,12,164,163,17,19,77,138,69,130
484 - 488		23,49,20,42,34,48,146,173,143,166,155,172,56,51,72,67,53,68,66,117,112,133,128,114,129,127,85,102,101,95,97,11,12,164,163,17,19,77,138,69,130
488 - 492	488 - 496	20,28,45,44,40,34,36,143,149,169,168,162,155,157,56,54,81,52,70,65,117,115,142,113,131,126,85,102,101,95,97,11,12,164,163,17,19,77,138,69,130
492 - 496		20,23,45,42,40,34,36,143,146,169,166,162,155,157,56,51,75,68,64,66,117,112,136,129,125,127,83,101,97,11,12,164,163,17,19,77,38,69,130
496 - 500		20,23,45,42,40,34,36,143,146,169,166,162,155,157,56,51,75,68,64,66,117,112,136,129,125,127,83,101,97,11,12,164,163,17,19,77,38,69,130

TABLE 21 – INRX FILTER PROGRAMMING TABLE

2.11.3.1 Reception filter tuning

Required instruments

Signal generator W&G PS 30 or equivalent

Selective voltmeter W&G SPM 30 or equivalent

Bandwidth programming

Program the filter for single or double channel, according to the programming table 21 – INRX FILTER PROGRAMMING TABLE

Filter test

The following procedures are applicable both to single or double channel filter.

Before arrange the test bench, set the INRX as follow:

- Open SZ-6 1-2 and 3-4
- Close SZ2 2-4 and open 1-3
- Exclude the input attenuator, open TC9, TC10, TC16 and close TC7, TC8, TC15.

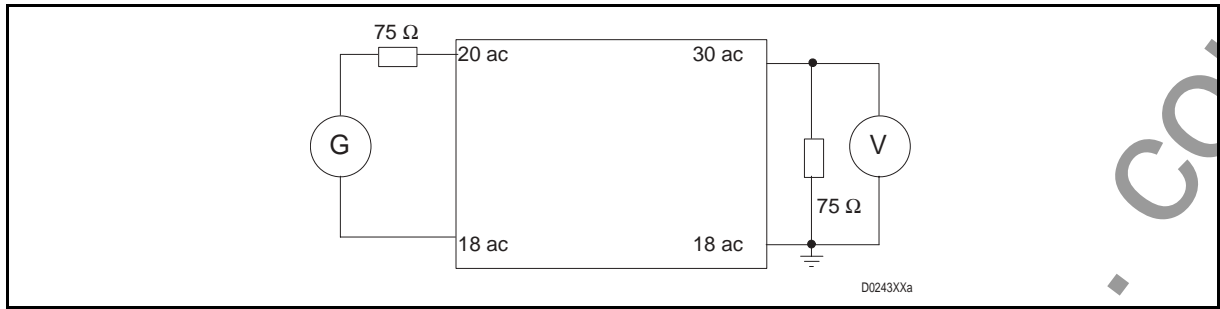

FIGURE 23 – RX FILTER TUNING TEST RIG

Arrange the test bench on according to figure 2.21

Send a test tone at frequency $F_x = F_c + 2\text{KHz}$ and level 0 dBv; (single channel)

Send a test tone at frequency $F_x = F_c$ and level 0 dBv; (double channel)

Adjust the three coils to get the minimum loss

Verify that the filter loss is within the value indicated on table 22 – RX filter maximum loss

FREQUENCY kHz		F_x
MIN.	MAX.	LOSS dB
40	168	≤ 1.0
168	320	≤ 2.0
320	496	≤ 3.2

TABLE 22 – RX FILTER MAXIMUM LOSS

Verify that the frequency response of the filter matches the mask on figure 24 – Frequency / loss mask single channel or figure 25 – Frequency / loss mask double channel.

Adjust the three coils to get the best frequency response.

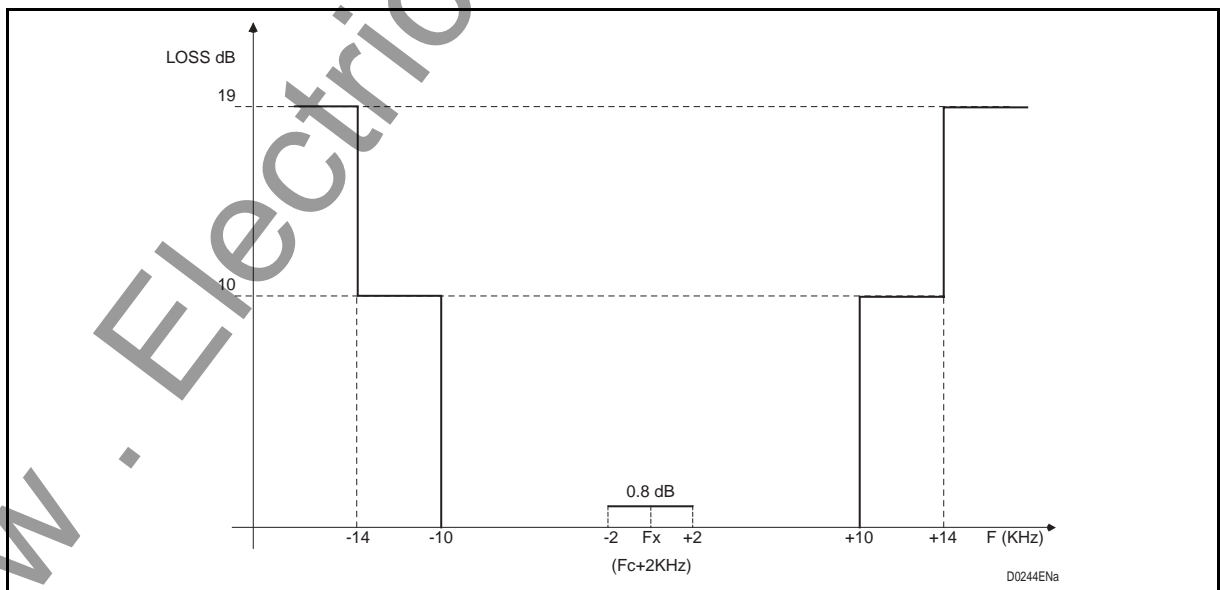

FIGURE 24 – FREQUENCY / LOSS MASK SINGLE CHANNEL

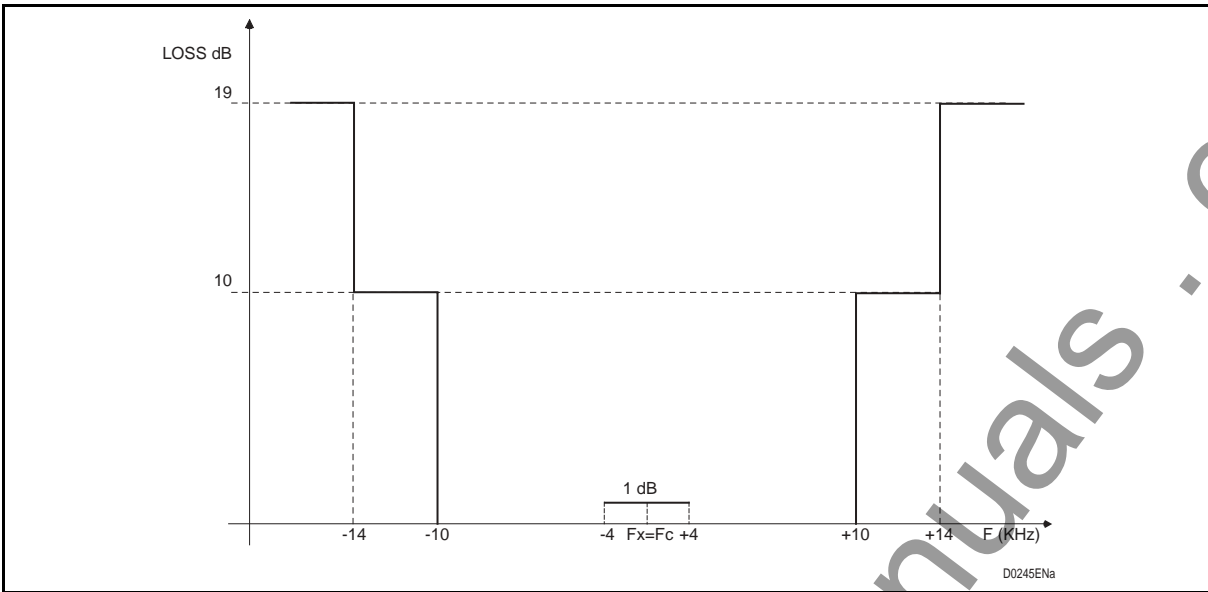

FIGURE 25 – FREQUENCY / LOSS MASK DOUBLE CHANNEL

NOTE: Completed the filter tuning procedures, set-up the filter according to your PLC HF characteristics.

www.ElectricalPartManuals.com

3. TEST AND COMMISSIONING

3.1 SW set-up

For this chapter, please refer to MMI section.

3.2 Required instruments

The measuring instruments and accessories necessary for the equipment start up are listed in the following table (quantity necessary for one team):

INSTRUMENTS AND ACCESSORIES	QTY.	TYPE
Digital meter	1	Type FLUKE 77 or equivalent
Signal generator	1	PS 30 W&G or equivalent
Selective voltmeter (level meter)	1	SPM 30 W&G or equivalent
Personal Computer	1	IBM compatible
Operating system		Windows® 3.x or higher
HF connection cable	1	
LF connection cable	2	

TABLE 23 – ACCESSORIES AND MEASURING INSTRUMENTS

3.3 Preliminary operation

Once the PLC is installed and connected to the other equipment and HF line matching unit, before switch on the power supply pay attention to few recommendations:

1. Put the PLC HF output on dummy load
2. Disconnect the power supply connector M1 and verify the correct connection (by means digital multimeter)
3. Verify the ground connection
4. Verify the HF cable connection
5. Verify the LF service connection
6. Verify that all the cards are in the right position and correctly inserted in the shelve
7. Verify that the top and bottom of the PLC are not obstructed

The recommendations are necessary because we assume that the commissioning engineer often does not follow also the installation activities.

The preliminary operations involve also all the matching unit, LMU presetting, Line Trap and coupling capacitors correct installation. We strongly suggest to check the HV line response without the PLC equipment, from LMU to LMU, to verify at the working bandwidth the line response, typical impedance, return loss.

Completed the preliminary operations, the PLC test can start.

3.4 PLC local test

3.4.1 Power Supply

Switch on the power supply (ALIM) and verify, through the LED's light on, that the PLC is fed.

On the front of the ALIM there are 2 LED and 5 test point.

Verify:

1. LED RED is off
2. LED GREEN is on
3. Verify the output voltage: from top to bottom the 5 test point are respectively +5V; -5V; +15V; -15V; -36V (refer to figure 26 – Power Supply test point)

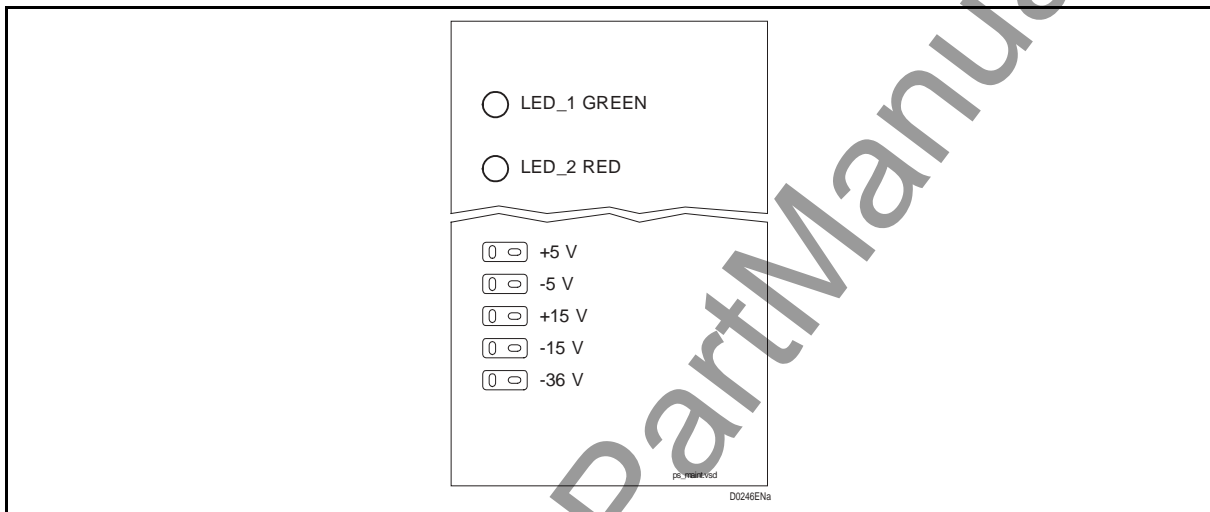

FIGURE 26 – POWER SUPPLY TEST POINT

Nominal DC voltage	Tolerance
+ 5 V, - 5 V, + 15 V, - 15 V	± 5 %
- 36 V	+ 10, -5 %

TABLE 24 – TOLERANCES

3.4.2 Transmission level

3.4.2.1 PLC led'S and test point

The following figure shows the location of the PLC LED's and test point.

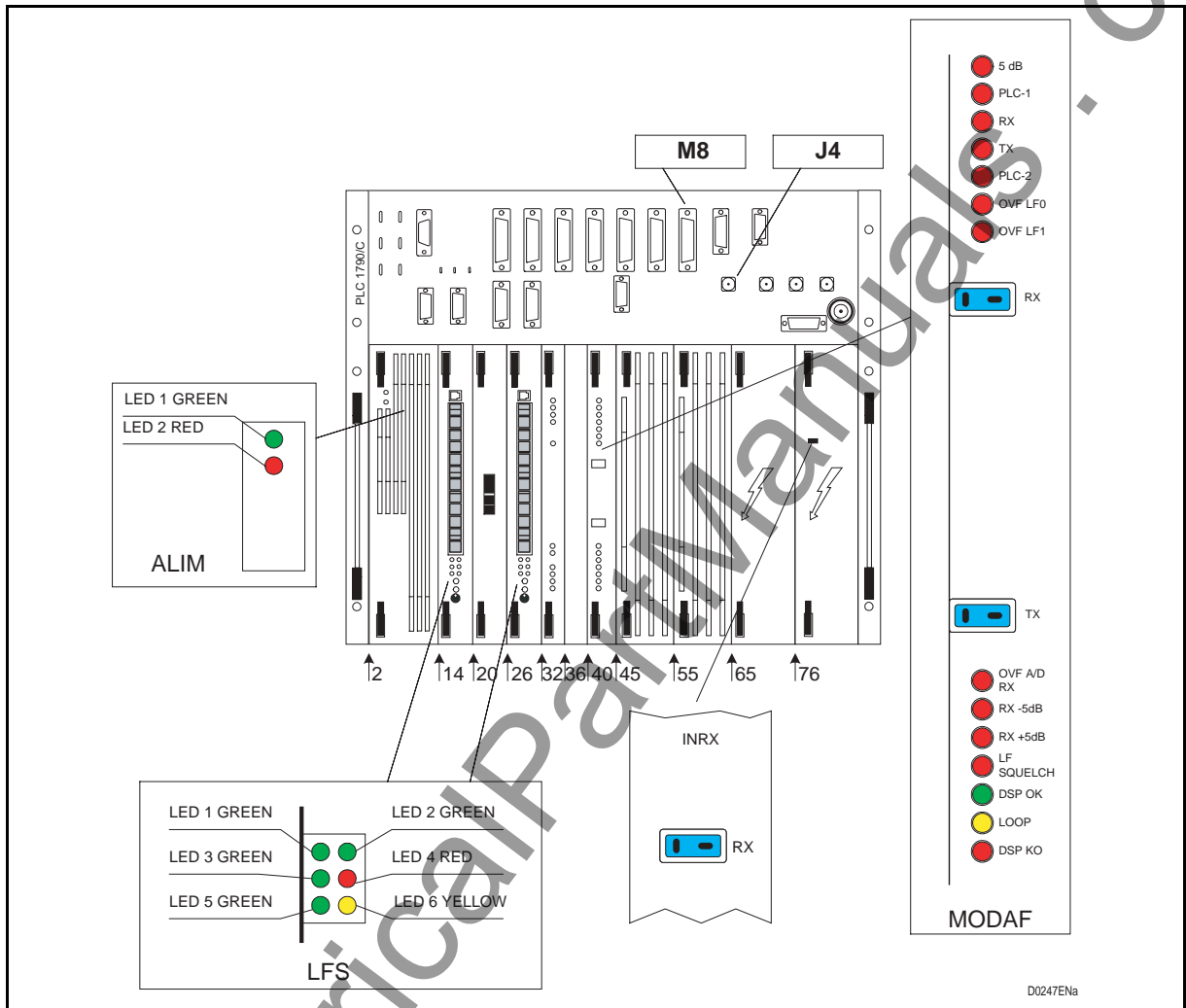

FIGURE 27 – PLC LED'S AND TEST POINT

3.4.2.2 Preliminary check

Once the PLC has been switched on, first verify the LED's status on MODAF card:

With the PLC off-line the following conditions should be verified:

Erreur ! Des objets ne peuvent pas être créés à partir des codes de champs de mise en forme.	LED	STATUS	DESCRIPTION	NOTE
	5dB	ON	5 dB	RX CARRIER not present
	RX	ON	RX	SIGNAL/NOISE RATIO ♦
	TX	OFF	TX CARRIER	HF TX CARRIER LEVEL WITHIN TOLERANCE
	RX -5dB	ON	RX Carrier	RX Carrier Level 5 dB or more lower than nominal level
	LF Squelch	ON	COMMON ALARM	RX Alarm active and HF demodulator blocked
	PLC1 PLC2 0 VF LF0 0VF LF1 0VF A/D RX RX -5dB RX +5dB LF squelch DSP LOOP			

TABLE 25 – MODAF LED'S OFF-LINE

In case that the LED TX is on, before continue with the local test verify that the transmission filter is correctly programmed and tuned, the power amplifier correct insertion. In any case, go to § 3.4.2.4 and perform the HF test.

More help will be found on section 6 MAINTENANCE.

3.4.2.3 LF service

First step is the LF section level check.

Proceed as follow:

Led'S indication

For each LED different conditions will be analysed. Refer to figure 29 – LF input levels .

Being the PLC not on line, only the valid indication are reported:

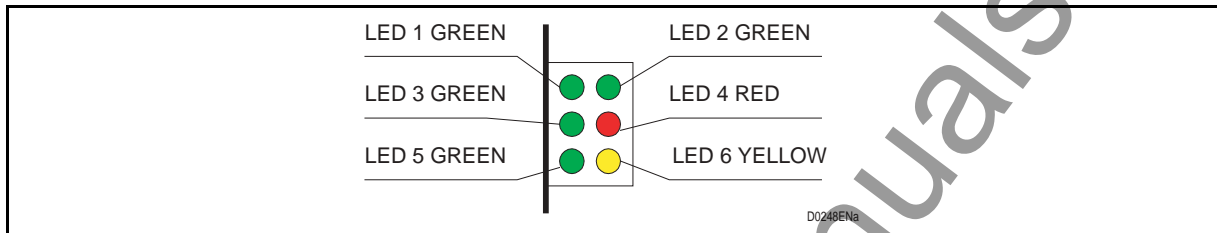

FIGURE 28 – LFS CARD LED'S

Led_4 FSK signalling RX failure (red colour)		
status	EFFECT	explanation
OFF	RX signal OK	1) PLC is on-line
ON	RX signal failure	2) PLC off-line 3) RX signal low 4) RX frequency wrong
led_5 DSP status (green colour)		
status	EFFECT	explanation
fast blinking fast	on-line operation	1) The unit is under normal operation
slow blinking	off-line operation	1) DSP on programming 2) DSP on test 3) DSP on WD 4) EEPROM empty
OFF	no operation	1) Card failure

TABLE 26 – LFS LED'S STATUS OFF-LINE

3.4.2.3.1 Input / output signal nominal level set-up

Completed the visual check, the HW test can start.

1. Load on the PC the MMI program;
2. Enable the connection with the LFS to be tested (refer to Man Machine Interface handbook)
3. Select the option "TEST". Starting from this moment the DSP generates on the SPEECH and TELEGRAPH output two test tones respectively at 800 Hz and 3180 Hz. The output attenuator affects the output level. The levels before the attenuator can be considered as nominal one;
4. Under TEST menu, select option "TEST TONES GENERATION" and then select the reference frequency. The DSP generates on the HF Line and LINE-2 output a test tone at the selected frequency and nominal levels; the output levels can not be adjusted.
5. Return to the TEST menu, select the options "INPUT LEVELS MEASUREMENT" and the following window will be showed

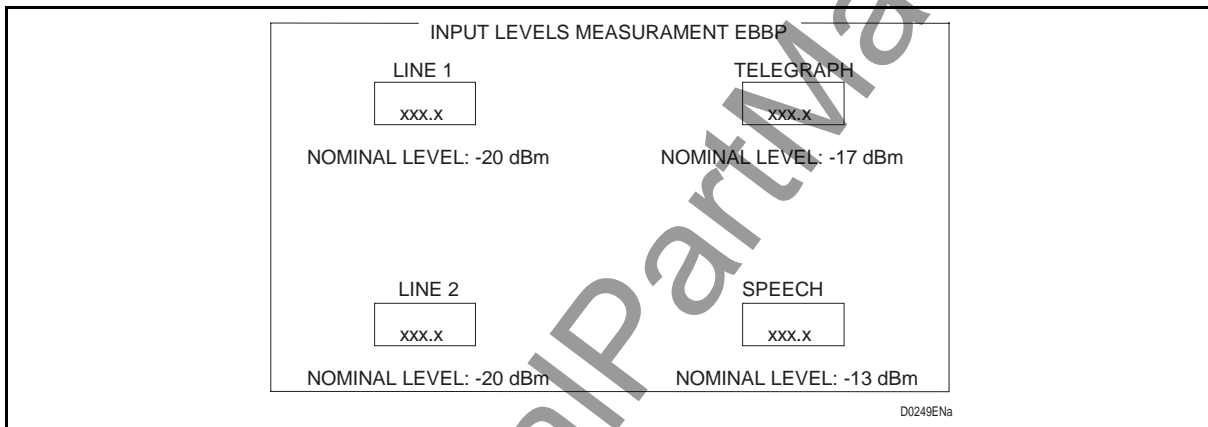

FIGURE 29 – LF INPUT LEVELS MEASUREMENTS

The following table shows the nominal input and output level for the LF services. With a selective meter check the output signal; in case that the levels are different from the nominal one, adjust the relative attenuator. For the input signal, by means signal generator, send the test tone and verify with the PC that the level shows on the display match the indicated one; whenever the two values do not match, adjust the relative attenuator (refer to MMI manual)

LF signal	Nominal level dBm	Ref. Frequency Hz	Input test point	Output test point
Speech 4w TX	-3.5	800	4W_TX	
Speech 2w TX	0	800	2W	
Speech 4w RX	-3.5	800		4W_RX
Speech 2w RX	-7	800		2W
Telegraph TX	-14	3180	TG_TX	
Telegraph RX	-14	3180		TG_RX
LINE 2 TX	-10	800	L2_TX	
LINE 2 RX	-10	800		L2_RX

TABLE 27 – LFS REFERENCE LEVELS

LFS input/output test points front view

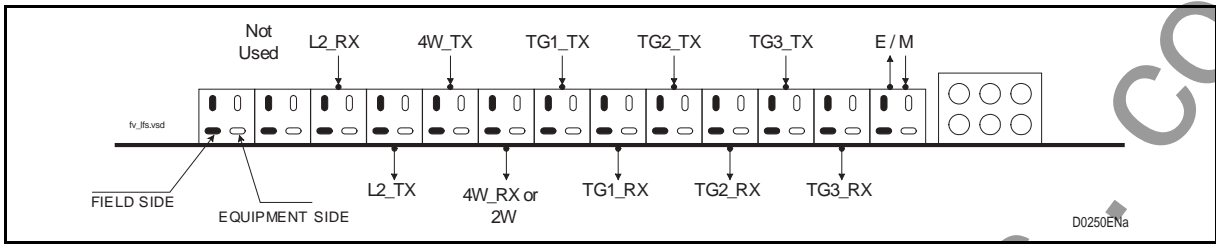

FIGURE 30 – LFS TEST POINTS

OPERATION

Proceed as follow:

Output signals

LF output tones to be checked	Procedure
Speech RX (4w and 2W)	<ol style="list-style-type: none"> 1) Set the level meter for 600 Ω input impedance and 800 HZ frequency 2) Check on 4W_RX the output level.
Telegraph RX	<ol style="list-style-type: none"> 1) Set the level meter for 600 Ω input impedance and 3180 HZ frequency 2) Check on TG_RX the output level.
Line 2 output	<ol style="list-style-type: none"> 1) Set the level meter for 600 Ω input impedance and at the frequency chosen by means the PC. 2) Check on L2_TX the output level.

Input signals

LF input measurements to be checked	Procedure
Speech TX 4w	<ol style="list-style-type: none"> 1) Set the signal generator for 600 Ω output impedance, 800 Hz and nominal level 2) Transmit the signal at 4W_TX test point 3) Read on the PC the measured level and compare with the reference one.
Speech TX 2w	<ol style="list-style-type: none"> 1) Set the signal generator for 600 Ω output impedance, 800 Hz and nominal level 2) Transmit the signal at 2W test point 3) Read on the PC the measured level and compare with the reference one.
Telegraph TX	<ol style="list-style-type: none"> 1) Set the signal generator for 600 Ω output impedance, 3180 Hz and nominal level 2) Transmit the signal at TG_TX test point 3) Read on the PC the measured level and compare with the reference one.
Line 2 input	<ol style="list-style-type: none"> 1) Set the signal generator for 600 Ω output impedance, 800 Hz and nominal level 2) Transmit the signal at L2_TX test point 3) Read on the PC the measured level and compare with the reference one.

TABLE 28 – LFS INPUT / OUTPUT HW TEST

Completed the LF service test, put the LFS on line.

3.4.2.4 HF level

We have only two test point for the HF section:

1. TX test point on MODAF card:
This test point is put before the Power Amplifier. The selective voltmeter has to set at High Impedance.
2. HF test point J4 on the motherboard:
This test point is located at the HF output, after the Power Amplifier, Transmission Filter and Line Hybrid. The level measured at this point is attenuated of 35 dB, the selective meter has to set at 75 Ohm.
3. There are no HW adjustments for the HF levels. Only by means SW tools, included on MMI, is possible to adjust the levels, beware that the regulation effects all the signals. For the procedure (refer to MMI section, § 6).
4. Repeat the procedure in table 28 and read with the selective meter at the indicated point.

The following table shows the reference levels excluding 7dB INAFattenuator:

Nominal input level		HF Interface -dBv- (TX test point)						HF Output 75 Ω -dBm- (J4 test point)					
		Single Channel			Double Channel			Single Channel			Double Channel		
Signal	dBm	10W	20W	40W	10W	20W	40W	10W	20W	40W	10W	20W	40W
Carrier		-14	-11	-11	-20	-17	-17	+22	+25	+28	+16	+19	+22
Speech 4W	-3.5	-6	-3	-3	-12	-9	-9	+30	+33	+36	+24	+27	+30
Speech 2W	0	-6	-3	-3	-12	-9	-9	+30	+33	+36	+24	+27	+30
Line-2 (speech)	-18	-6	-3	-3	-12	-9	-9	+30	+33	+36	+24	+27	+30
Telegraph 1	-14	-12	-9	-9	-22	-15	-15	+20	+23	+26	+14	+17	+20
Telegraph 2	-14	-12	-9	-9	-22	-15	-15	+20	+23	+26	+14	+17	+20
Signalling	FSK	-12	-9	-9	-22	-15	-15	+20	+23	+26	+14	+17	+20
MTU	200 Bd	-10	-7	-7	-16	-13	-13	+26	+29	+32	+20	+23	+26

TABLE 29 – HF REFERENCE LEVELS

The above levels are valid with the PLC HF output on dummy load.

3.4.2.4.1 LINE 2 level

According to the LFS programming, the LINE-2 can be considered as an output of the PLC, working on 0 ÷ 4 kHz band.

Nominal input level		LINE-2 TX - dBm-
Signal	dBm	
Speech 4W	-3.5	-18
Speech 2W	0	-18
Telegraph 1	-14	-28
Telegraph 2	-14	-28
Signalling	FSK	-28

TABLE 30 – LINE-2 NOMINAL INPUT LEVEL

3.4.2.5 On line test

Completed the test on dummy load, switch the PLC output to the HF line.

1. Repeat the HF level measurement; point 3.4.2.4/2
2. Adjust the HF Hybrid balancing taking as reference the PLC carrier.

3.5 End to end LINE TEST

3.5.1 Overview

The test to perform on the reception side assume that at the remote end is available another operator, able to transmit the test tone and activate the equalization procedure (see MMI section §11 & §9 for this operation).

Basically the main test are performed on two signals:

- RX Carrier
- Test tone equivalent to a speech nominal signal
- LF band equalisation

3.5.2 HF received signal

Once the PLC is on-line verify the LED's status:

The indications given by the MODAF LED's are of two different types:

- Equipment alarm
- Line alarm

RX carrier indications

	LED	STATUS	DESCRIPTION	NOTE	
	5 dB		5 dB	RX CARRIER	
		ON	RX CARRIER LEVEL LOW	5 dB lower than nominal level or not received	
		OFF	RX LEVEL OK	Carrier received	
	RX		RX	SIGNAL/NOISE RATIO	
		ON	S/N ALARM ACTIVE	Signal to low or noise to high at PLC HF input.	
		OFF	RX PARAMETERS OK	Levels OK	
	RX -5dB				
		ON	RX CARRIER LEVEL LOW	5 dB lower than nominal level or not received	
		OFF	RX LEVEL OK	Carrier received	
	RX +5dB				
		ON	RX CARRIER LEVEL LOW	5 dB higher than nominal level	
		OFF	RX LEVEL OK	Carrier received	
	ON	INPUT LEVEL OVERLOADED	(PLC on PARALLEL or BAD HF LINE MATCHING)		
	OFF	INPUT LEVEL OK			
LF SQUELCH					
	ON	LF SERVICE BLOCKED	Any of alarm programmed by MMI		

FIGURE 31 – MODAF LED'S

TABLE 31 – MODAF LED'S ON-LINE

If the two LED's are OFF, it means that the reception carrier is received and the AGC is working properly.

Verified thus conditions proceed to the reception level check.

RX level check

On the PLC 1790 only two test point are available to test the received level. On the reception path, before the RX filter, is available a variable attenuator to set-up as follow:

PLC HF Power	Attenuator	note
10 W single channel 10/20/40 W double channel	6 dB	If the HF line attenuation is very low, the operator can decided to include more attenuator, but never go under the indicated one.
20 W single channel	9	
40 W single channel	12	

TABLE 32 – RX INPUT ATTENUATOR

The maximum attenuation is of 18 dB.

RX test point

The first test point is located on the RX line interface and among the HF Hybrid and RX line attenuator. The selective meter must be on high impedance.

The level read on this point is 12 dB lower than the received one, on the HF input.

The second test point is on the MODAF card and called "RX".

This point is positioned after the AGC -Automatic Gain Control device-. The level read on this point must match the nominal one.

No adjustments are available.

To verify the AGC working point, refer to the MMI section §10 "ON LINE MEASUREMENT".

Verified the correct level of the signal after the AGC, proceed with the LF band equalisation.

3.6 LF band EQUALISATION

PLC 1790 equipment performs the LF band equalisation function. Two operators are needed, in case of lack off INSU card, and through the MMI program (refer to MMI section § 9) it is possible generate eight test tones and send them to the remote PLC. The remote operator choosing the command NEW EQUALISER and Self-Training Equalisation can equalise automatically the received frequencies transmitted by the remote station. A window will show a bar graphic with the 8 test tones to the operator before and after the equalisation function. If the equalised frequencies are good enough, the operator clicking on "ENABLE" command can activate the equalisation curve.

The operator can save the on-screen equalisation in a file standard Windows dialogue box.

The operator can design an Handmade equalisation curve choosing for each test tone the attenuation value in the range from -6 to +6 dB.

Each equalisation curve can be saved in a file and printed using the commands presented in the MMI section.

In order to evaluate the quality of transmission link the operator can check the connection with the remote PLC measuring the link fidelity with or without EQUALISER

3.7 LF received signal

Completed the HF test, the operator can verify the output level on LF band.

The operator on the remote end transmits the test tones, as indicated on the transmission section. On the receiver PLC, the other operator verify the output level.

3.8 LED INDICATION

For complete LED's indication, refer to the Maintenance section.

3.9 LF end to end verification

3.9.1 Line response

Completed the PLC's test, the operators, available at both end of the link, can verify the end to end response of the PLC's link.

- Speech bandwidth **300 ÷ 2000**

A -3.5 dBm signal will be transmitted from one end at Speech 4W input.

Check at the corresponding output of the other equipment that the relative level is within the limits indicated hereafter.

- LINE-2 bandwidth **300 ÷ 3720**

A -18 dBm signal will be transmitted from one end at LINE-2 input.

Check at the corresponding output of the other equipment that the relative level is within the limits indicated hereafter.

- Telegraph bandwidth **2160 ÷ 3480**

A -14 dBm signal will be transmitted from one end at Telegraph input.

Check at the corresponding output of the other equipment that the relative level is within the limits indicated hereafter.

www.ElectricalPartManuals.com

SPEECH equivalents

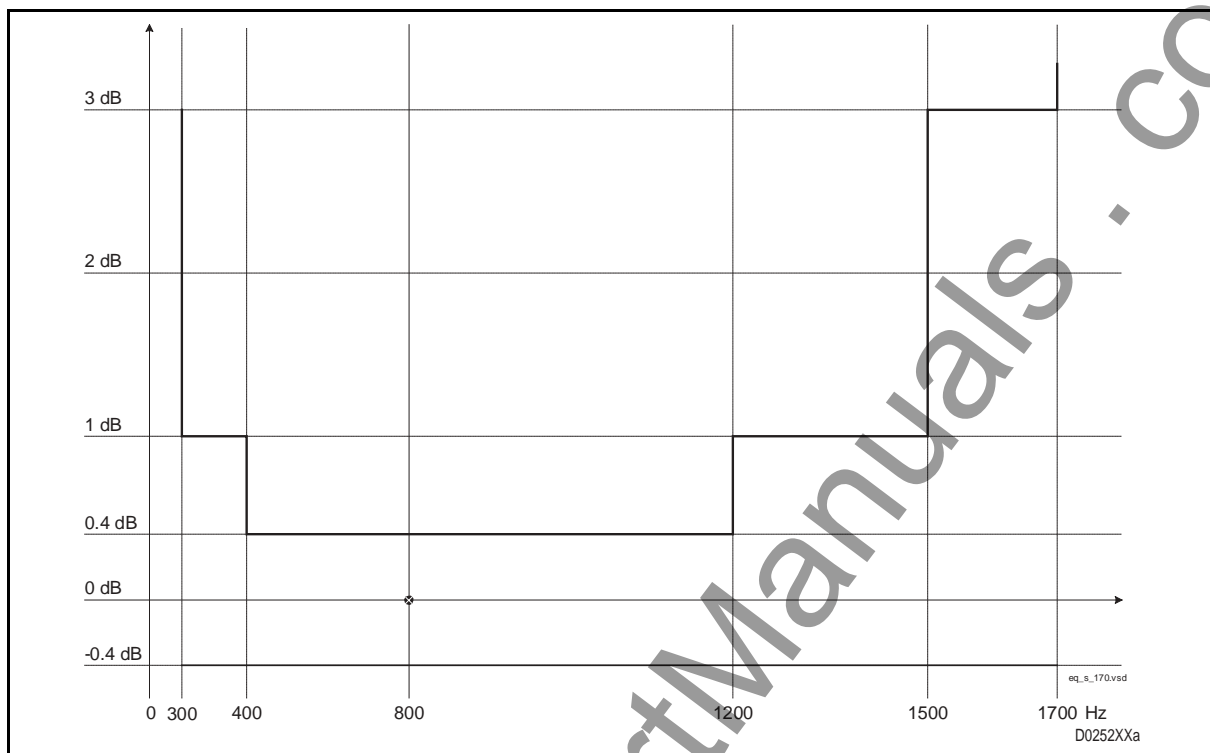

FIGURE 32 – SPEECH 300 ÷ 2000 HZ EQUIVALENT

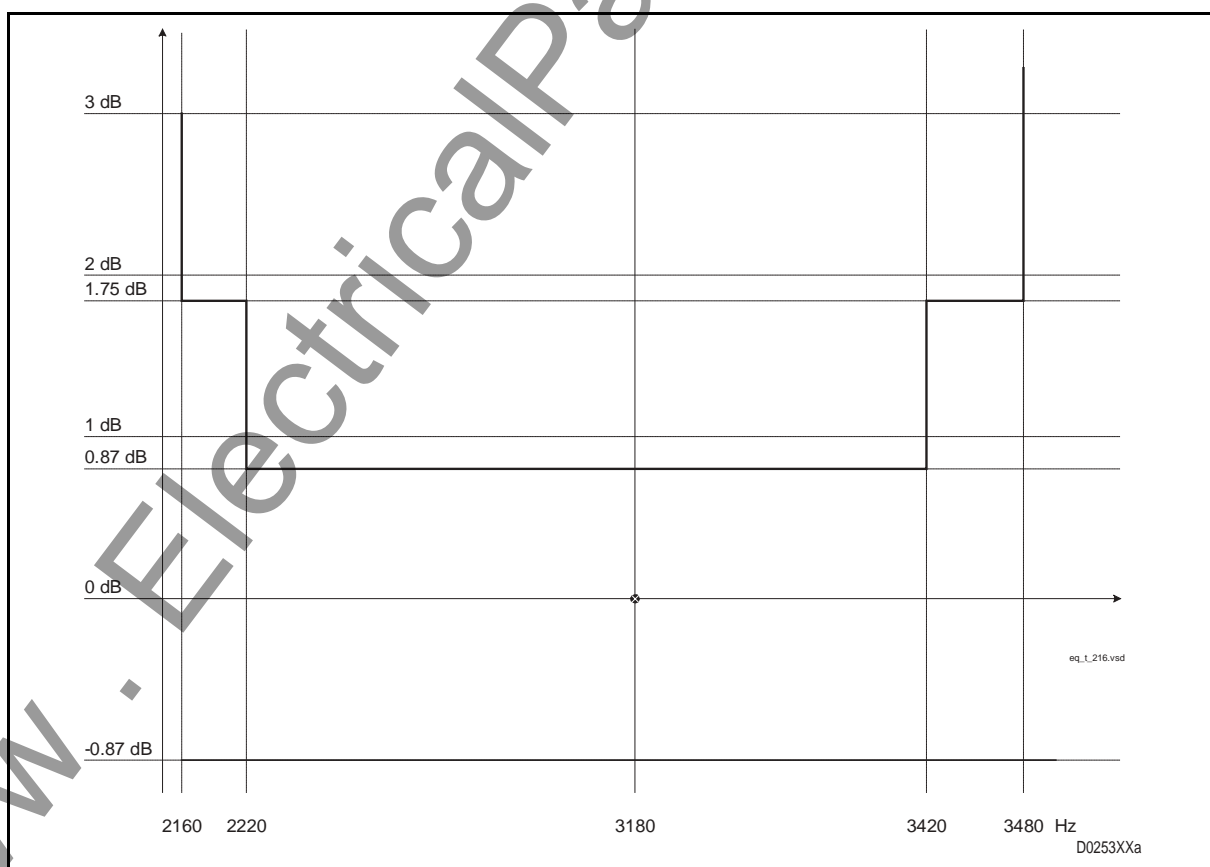

FIGURE 33 – TELEGRAPH 2160 ÷ 3480 HZ EQUIVALENT

Others LF response curves are in the ANNEX A

3.9.2 Signalling verification

Enable the switch on LFS front panel and push the remote service telephone call push button (C.TX) in order to send to the remote PLC equipment a call.

In the remote PLC terminal, check LED-6 (C.RX) in ON status and the buzzer activated during the incoming call.

Enter a ground polarity in "M" wire signalling input in Pin 9 of LFS field connector and check in the remote station in Pin 10 of LFS field connector a ground criteria.

3.9.3 2/4 wires automatic exchange criteria

In order to verify the 2/4 wires automatic exchange criteria check the 2 or 4 wires speech mode (MMI point 8.3.2) and send from the remote PLC terminal a speech frequency at relative nominal level (0 dBm 2 wires, -3,5 dBm 4 wires).

In the local PLC equipment connect a selective voltmeter, set at the same transmitted frequency and terminated on 600 ohm, to Pin 2 and 3 of LFS field connector and verify the nominal level.

Connect ground criteria on Pin 25 of LFS field connector and verify a level which change of 3,5 dB referring to the previous one.

3.9.4 Alarms and LED'S verification

Completed the previous tests, with the PLC equipment on line, proceed with the Alarms and LED's control.

Through the MMI program, enter in the "MODAF board measurement window" (MMI point 10) and check the "ON LINE MEASUREMENT" AGC level, Noise level and the 12 Alarm Flags.

The AGC on line measurement should detect an AGC gain close to 0. In order to adjust the AGC gain close to 0, the operator can modify the complementary HF line attenuator located on INRX board.

All the Alarm Flags must be shown in green colour.

The operator can monitor the Measurement and Alarm Flags and record them by fixed range period from 1" up to 120' or each time the position of AGC, the noise level or alarm status change. The parameters can be saved on disk file.

LED verification

With the PLC on line, verify the status of the LED's located on card front panels.

UNIT	COLOUR		STATUS	
LFS	Green	Green	②	②
	Green	Red	ON	OFF
	Green	Yellow	①	OFF
MODAF	5 dB	Red	OFF	
	PLC1	Red	③	
	RX	Red	OFF	
	TX	Red	OFF	
	PLC2	Red	③	
	OVF LF0	Red	OFF	
	OVF LF1	Red	OFF	
	OVF A/D RX	Red	OFF	
	RX -5 dB	Red	OFF	
	RX +5 dB	Red	OFF	
	LF SQUELCH	Red	OFF	
	DSP OK	Green	①	
	LOOP	Yellow	OFF	
	DSP KO	Red	OFF	

TABLE 33 – PLC LED'S IN IDLE CONDITION

② = According to the modem programming

① = Fast blinking

③ = According to SW programming

Alarm verification

Check the free changeover relay contacts presented in the following figure in their idle condition.

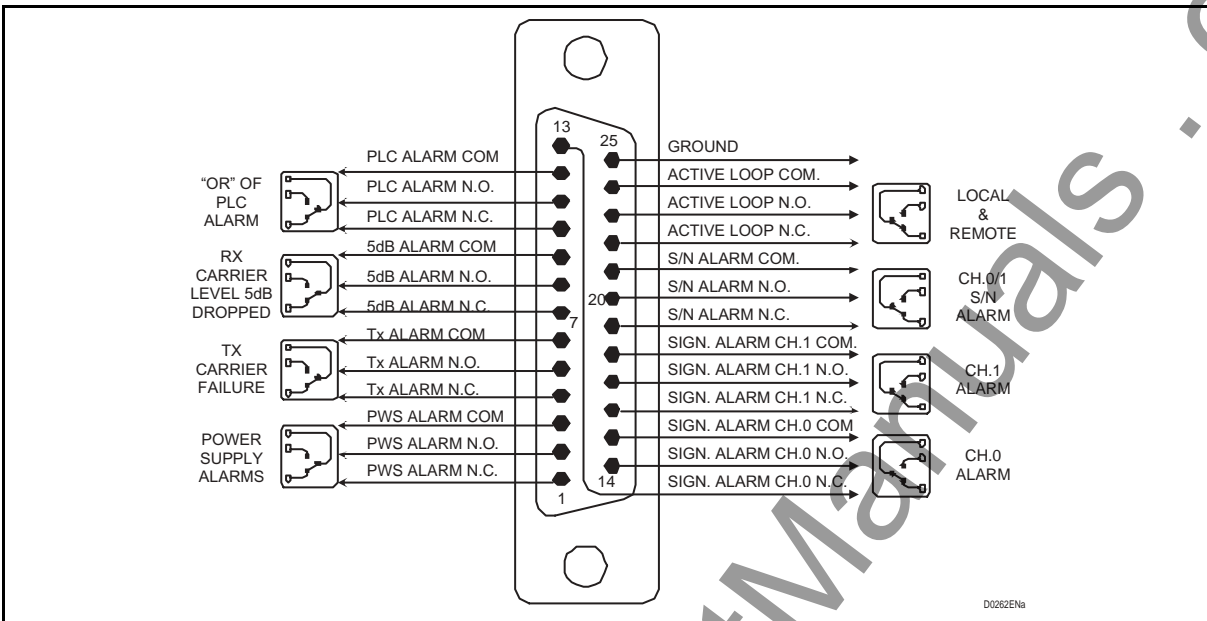

FIGURE 34 – M8 ALARM FIELD CONNECTOR

Control of LFS signalling alarm due to -5 dB level drop.

Connect to Pin 13 and 7 of LFS connector field a +24 Vdc LF RX suppression criteria and check that the free changeover relay contacts (Pin 20-21-22) of M2 field connector (LFS 0) and M3 field connector (LFS 1), if equipped, change their standpoint.

Check also the grounded contact (Pin 11) of M2 field connector (LFS 0) and M3 field connector (LFS 1) if equipped.

Disconnect the + 24 Vdc criteria and verify the relay contacts go back to idle condition

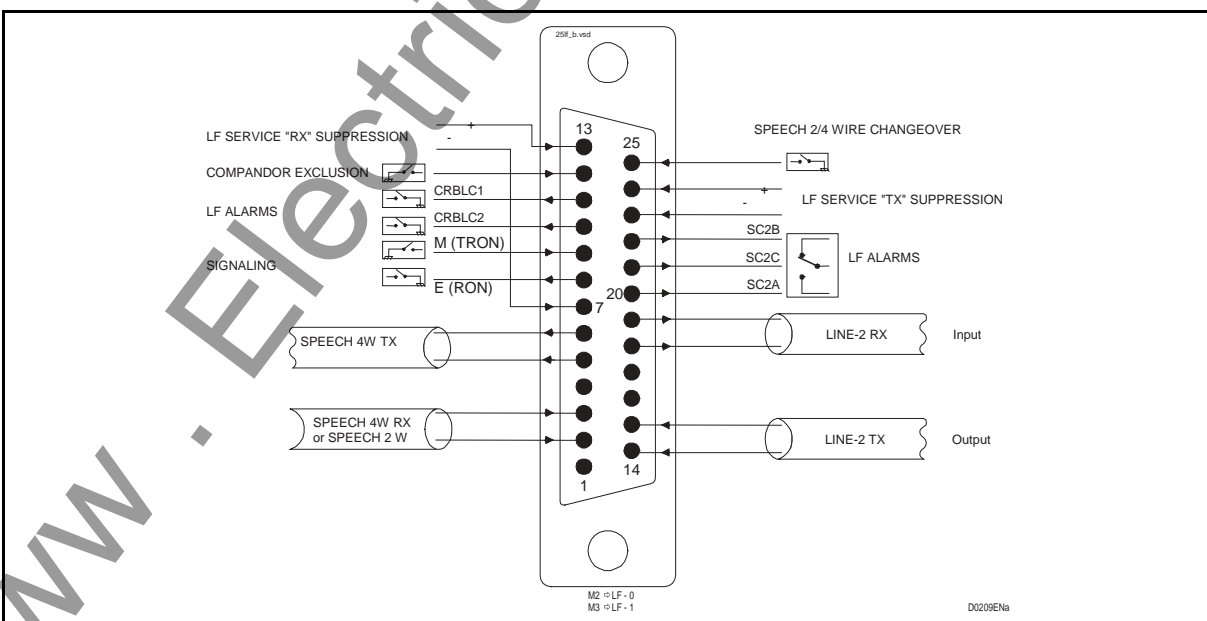

FIGURE 35 – LFS FIELD CONNECTOR M2 - LF0 OR M1 - LF1

Completed the start-up test, connect the field connectors to the customer services, fill in the commissioning report sheet and the PLC 1790 equipment is ready to get in service.

4. ANNEX

4.1 Speech channel

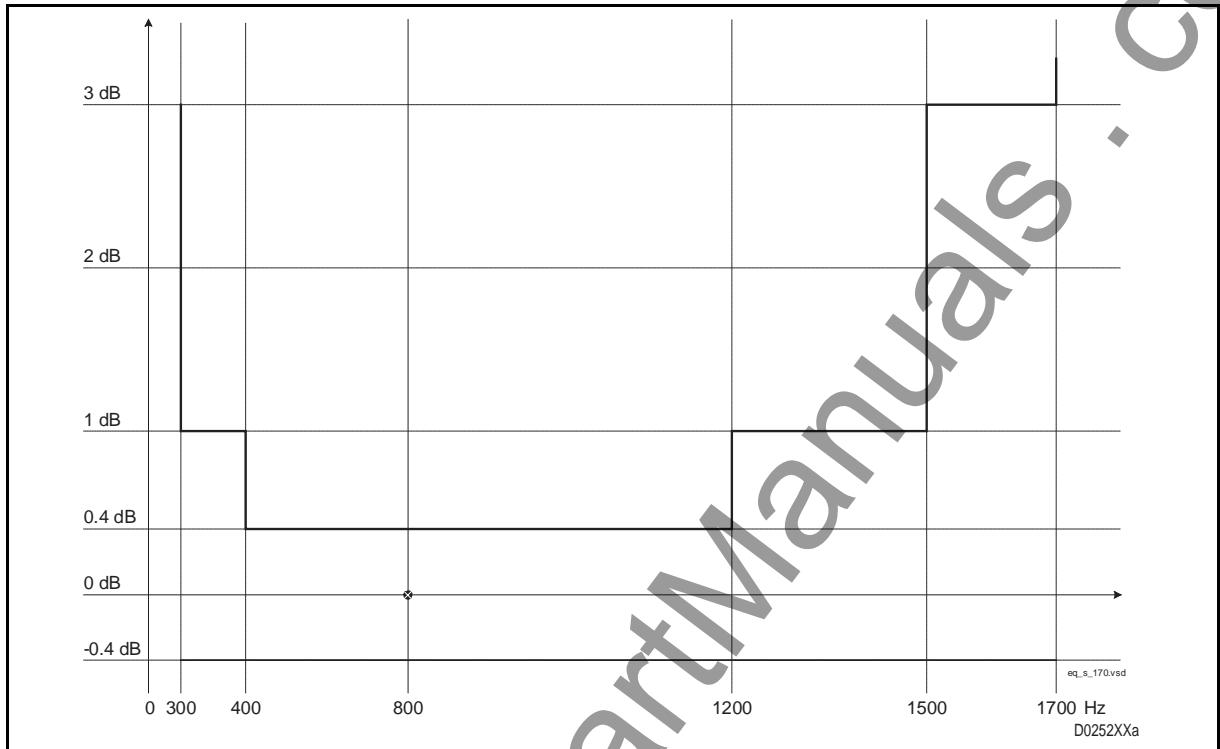

FIGURE 36 – SPEECH 300 ÷ 1700 HZ

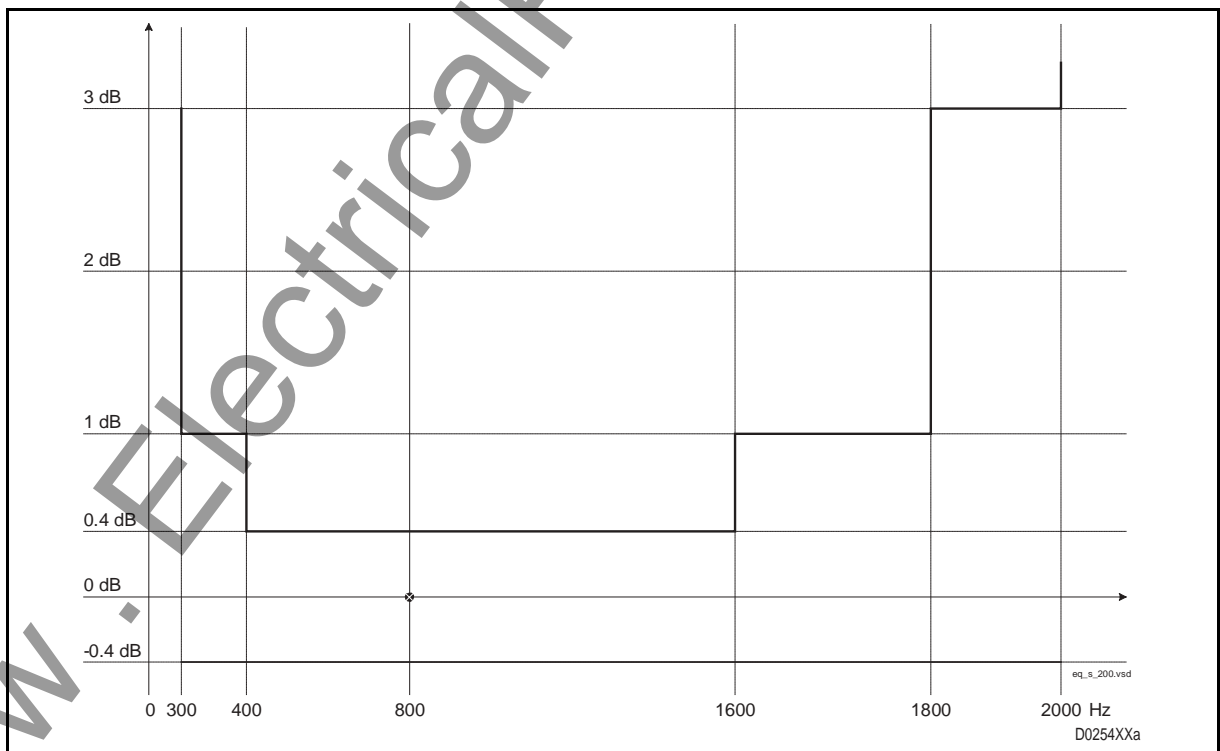

FIGURE 37 – SPEECH 300 ÷ 2000 HZ

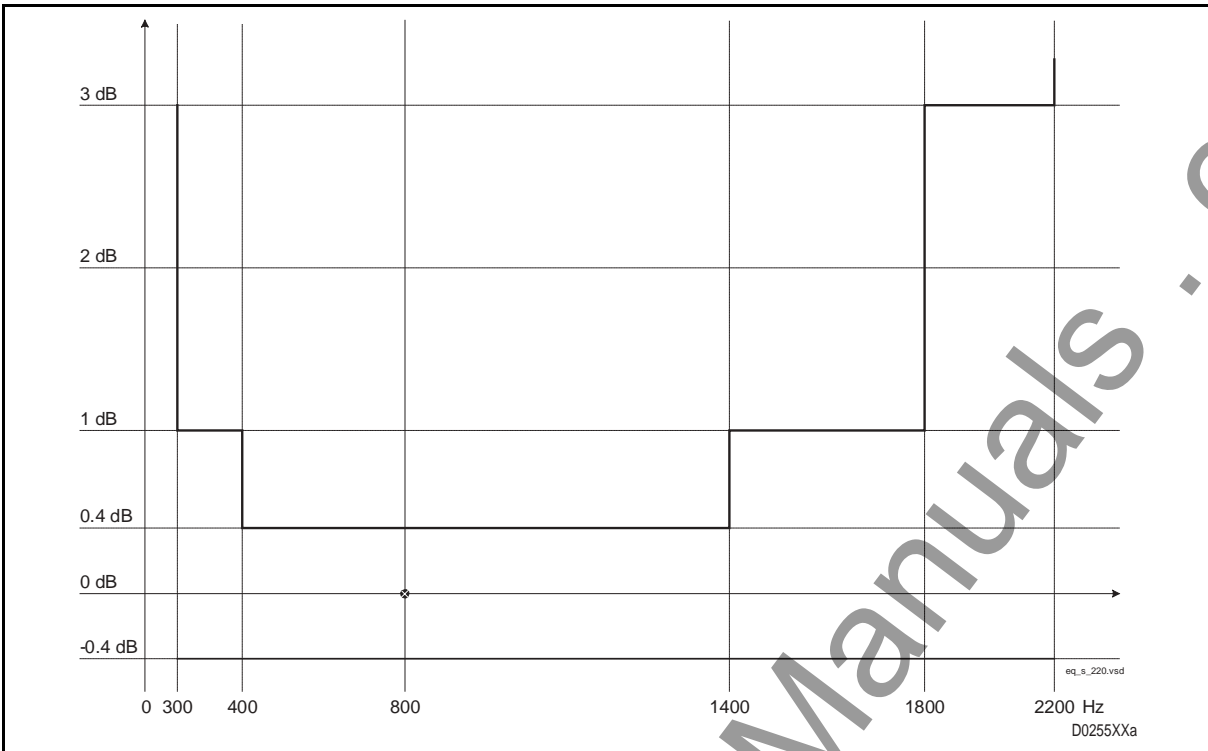

FIGURE 38 – SPEECH 300 ÷ 2200 HZ

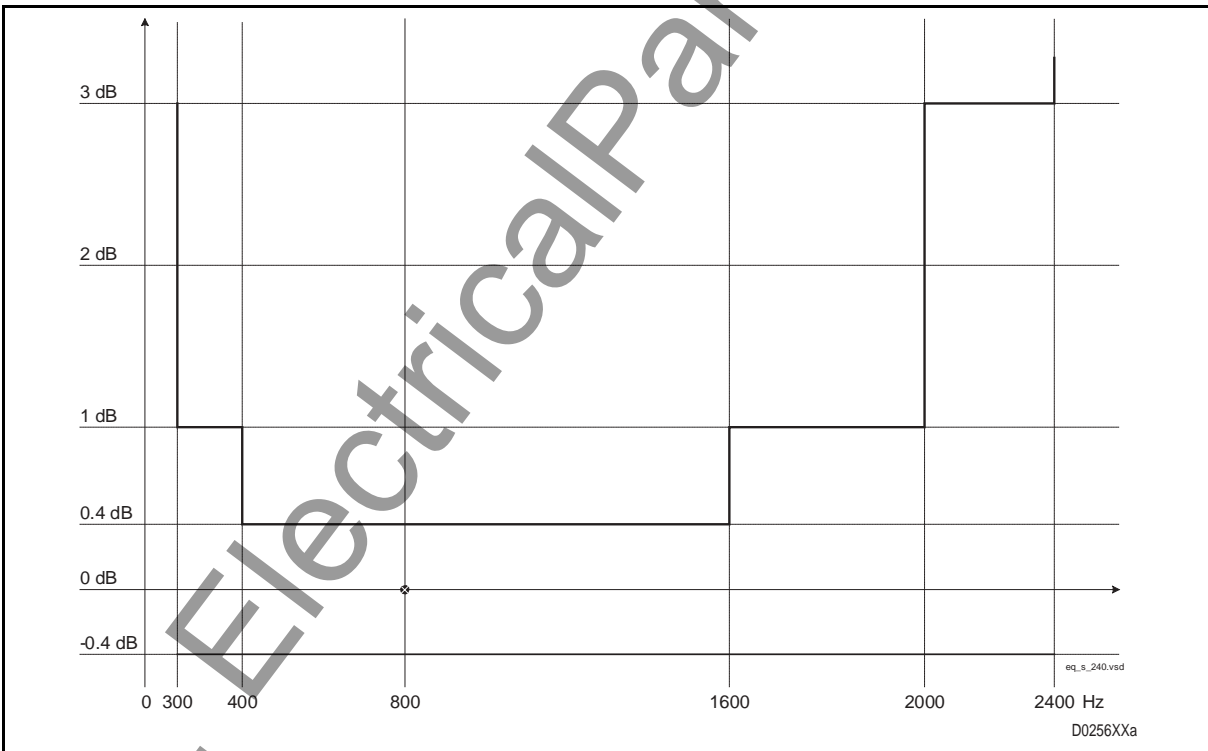

FIGURE 39 – SPEECH 300 ÷ 2400 HZ

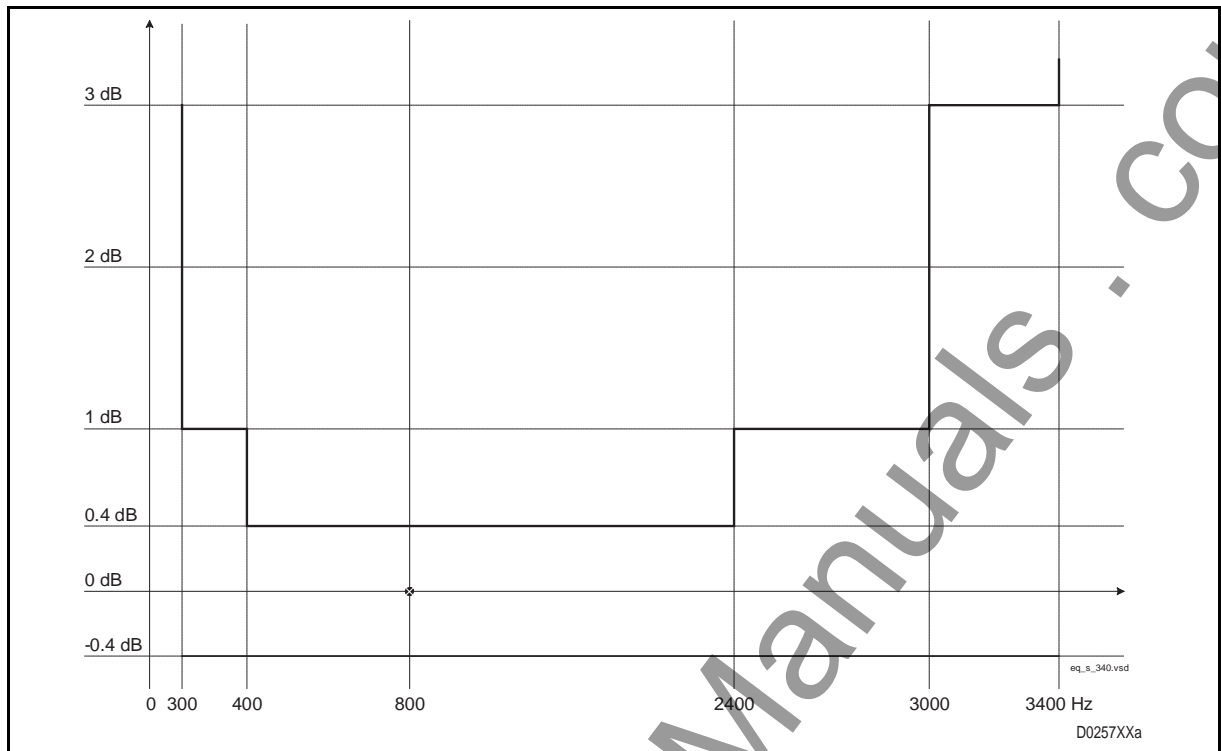

FIGURE 40 – SPEECH 300 -3400 HZ

www.ElectricalPartManuals.com

4.2 Telegraph channel

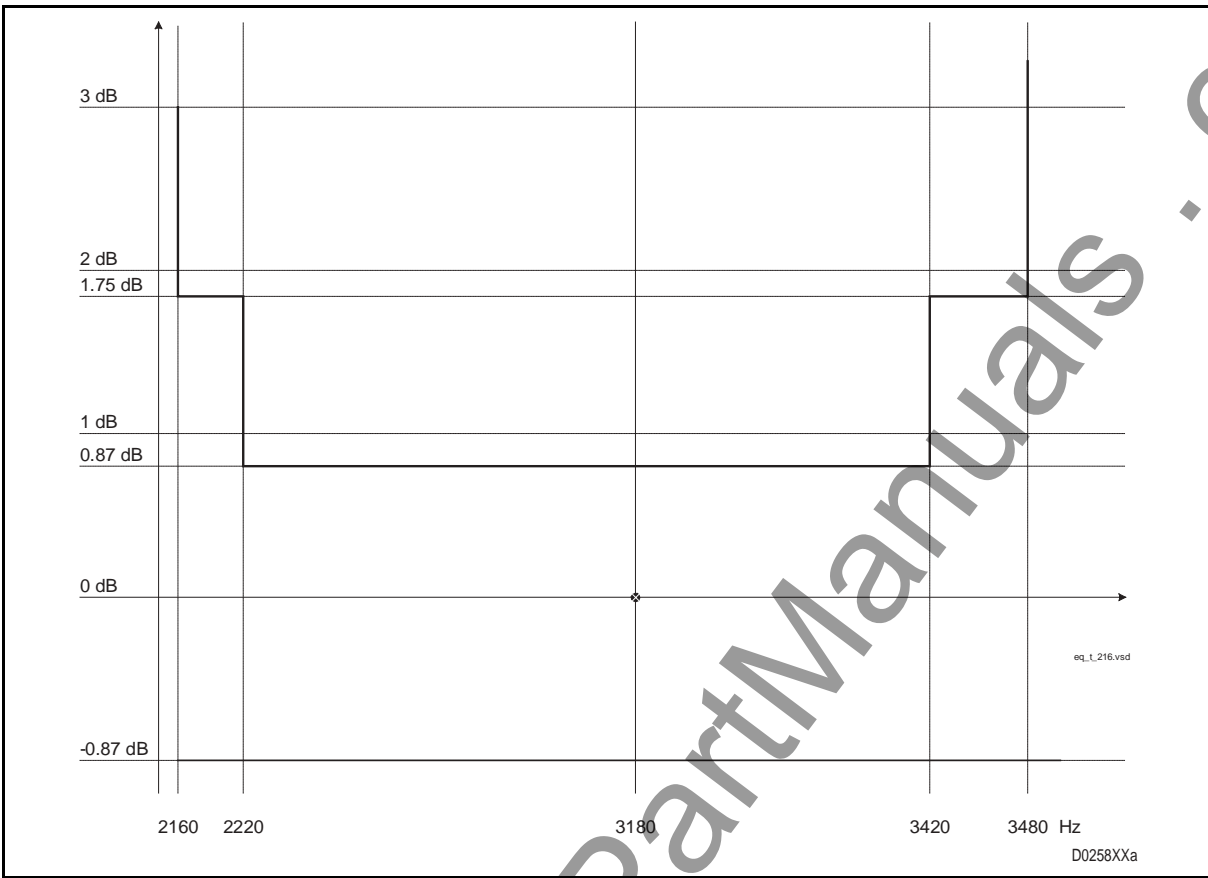

FIGURE 41 – TELEGRAPH CHANNEL 2160 ÷ 3480 HZ

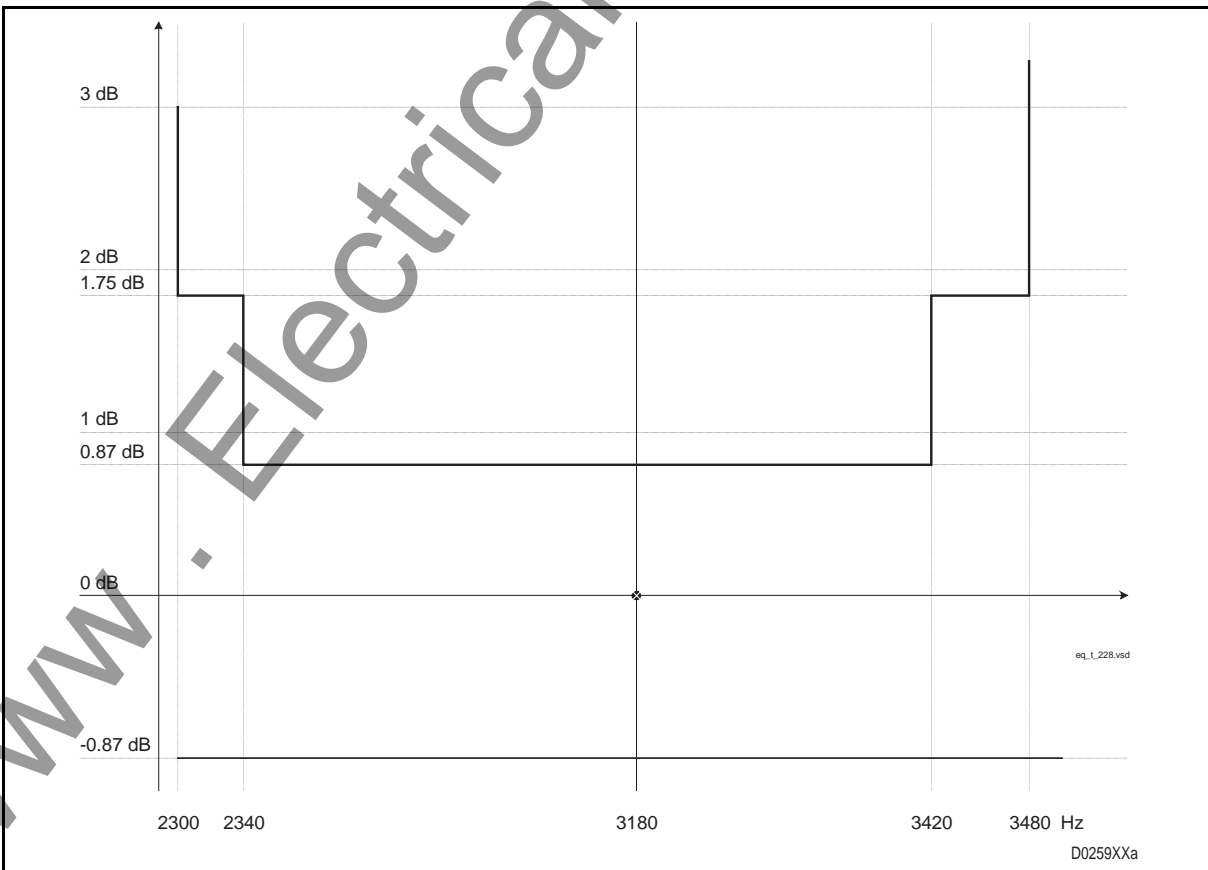

FIGURE 42 – TELEGRAPH CHANNEL 2300 ÷ 3480 HZ

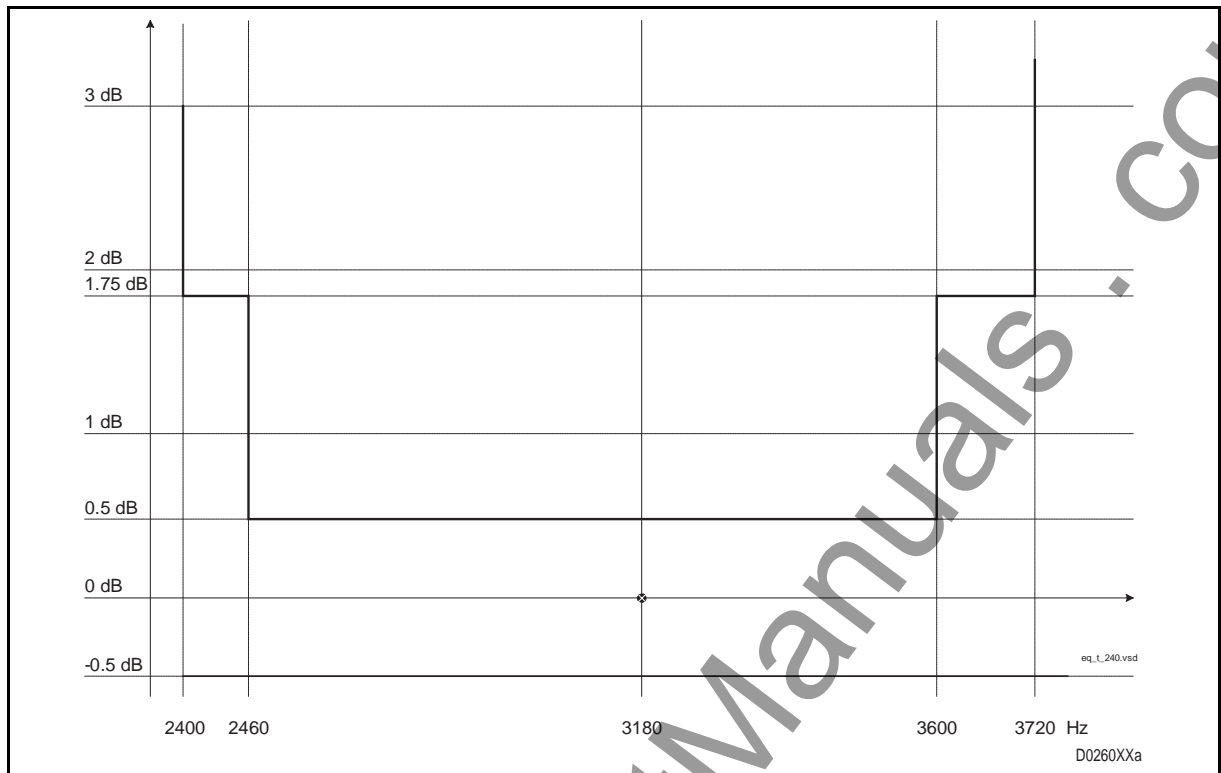

FIGURE 43 – TELEGRAPH CHANNEL 2400 ÷ 3720 HZ

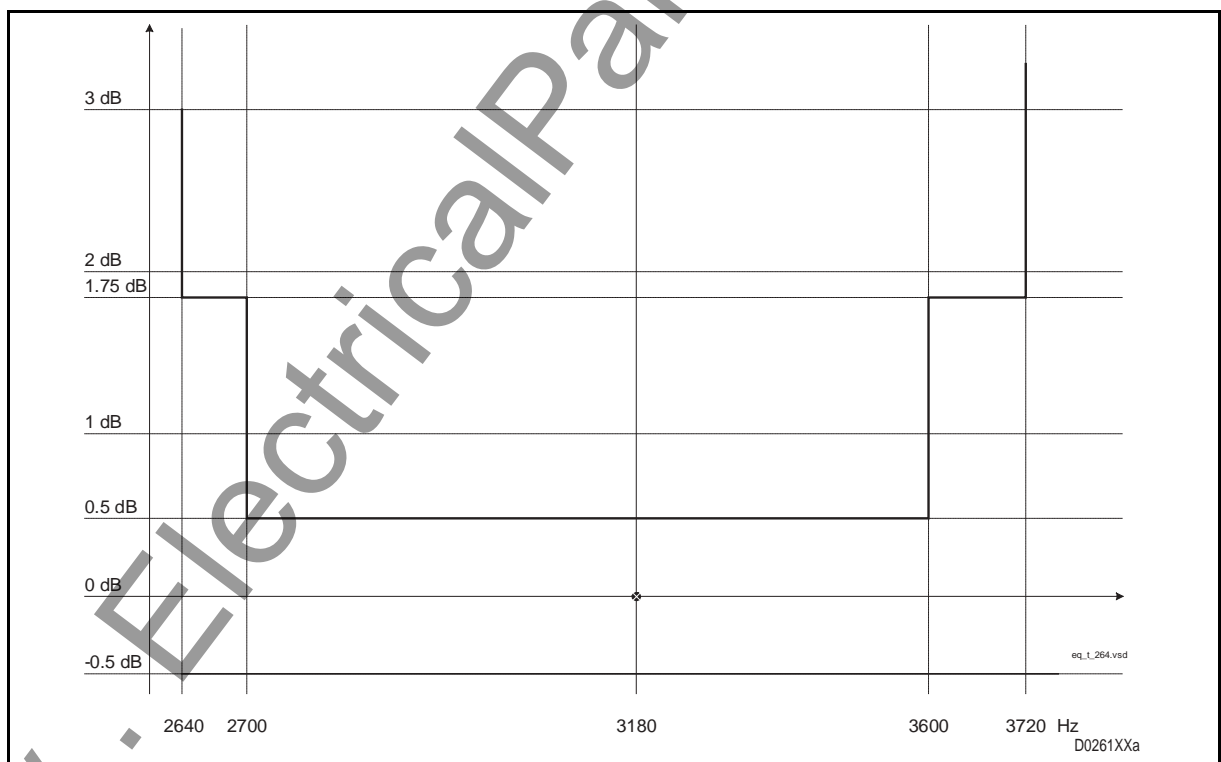

FIGURE 44 – TELEGRAPH CHANNEL 2640 ÷ 3720 HZ

BLANK PAGE

www.ElectricalPartManuals.com

HUMAN MACHINE INTERFACE

www.ElectricalArtManuals.com

www.ElectricalPartManuals.com

CONTENTS

1.	GENERAL	7
1.1	Definitions	7
1.2	Foreword	8
1.3	System requirements	8
1.4	Installation of the MMI	8
1.5	MMI Operator Mode	9
1.6	Running the MMI	9

2.	MAIN SCREEN	10
2.1	Title bar	10
2.2	Menu bar	10
2.3	State bar	10
2.4	Working and dialogue zone	10

3.	BASE WINDOW	11
3.1	Menu bar	11
3.1.1	Tools menu	11
3.1.2	Setup	13
3.1.3	Buttons on the image of the PLC 1790	14
3.1.4	Equalization	14
3.1.5	On line measurements	14
3.1.6	Tests	15
3.1.7	Loop	16
3.1.8	Supervisory	17
3.1.9	Help	17
3.2	State bar	19
3.2.1	Local Loop status	19
3.2.2	Test Mode	20
3.2.3	User Level	20

4.	MODAF BOARD SETUP	21
4.1	Start configuration	21
4.2	Menus	23
4.2.1	Tools	23
4.2.2	File	23
4.2.3	Read Setup	23
4.2.4	Write Setup	24
4.2.5	Compare data	24
4.2.6	Help	24

4.3	State bar	25
4.3.1	Source	25
4.3.2	FW field	25
<hr/>		
5.	ELNU BOARD SETUP	26
5.1	Start configuration	26
5.2	Menus	26
5.2.1	Util	26
5.2.2	File	26
5.2.3	Read Setup	27
5.2.4	Write Setup	28
5.2.5	Compare data	28
5.2.6	Help	29
5.3	State bar	29
5.3.1	Source	29
5.3.2	Fw field	29
5.4	Working window particularity	29
<hr/>		
6.	UBBP BOARDS SETUP (PLC1790)	30
6.1	Menu bar	30
6.1.1	File	30
6.1.2	Read Setup	31
6.1.3	Write Setup	31
6.1.4	Help	31
6.2	State bar	31
6.2.1	Source	31
6.2.2	Fw field	31
6.3	Working window	31
<hr/>		
7.	LFS BOARDS SETUP WINDOW	33
7.1	Menu bar	33
7.1.1	Tools	33
7.1.2	File	33
7.1.3	Read Setup	33
7.1.4	Write Setup	34
7.1.5	Help	34
7.2	State bar	34
7.2.1	Source	34
7.2.2	Fw field	34
7.3	Working window	34
7.3.1	Levels tab	34
7.3.2	Advanced Functions tab	35
7.3.3	Teleprotection TAB	38

8.	LOW FREQUENCIES EQUALIZER WINDOW	41
8.1	Menu bar	41
8.1.1	Equalizer	41
8.1.2	Measure Channel	42
8.1.3	Help	42
8.2	Working windows	42
8.2.1	Self Training Equalizer	42
8.2.2	Handmade Equalizer	46
8.2.3	Current Equalizer	49
8.2.4	Measure Channel	50

9.	MODAF/ELNU BOARD ON LINE MEASUREMENTS	53
9.1	Menu bar	53
9.1.1	Util	53
9.1.2	Measurements	53
9.1.3	Monitor	53
9.1.4	Help	54
9.2	State bar	55
9.2.1	Measurements type	55
9.2.2	Monitoring type	55
9.2.3	Records Number	55
9.3	Working windows	55
9.3.1	On-Line Measurements window	55
9.3.2	Records File windows	57

10.	AUDIO FREQUENCIES TESTS	59
10.1	Menu Bar	59
10.1.1	UTIL	59
10.1.2	Test	60
10.1.3	Help	60
10.2	State bar	60
10.2.1	Test on	60
10.2.2	Tones transmitted on HF and L2	60
10.3	Working windows	61
10.3.1	Tones Generation On HF and L2	61
10.3.2	Input Measurement	62

11.	LOOP TEST	63
11.1	Local	63
11.1.1	PLC local loop enable	63
11.1.2	Local loop disable	64
11.2	Remote loop test	64

12.	PRINT FEATURES	66
12.1	Print SUB-MENU	66
12.2	Fonts SUB-MENU	66
12.3	QUIT THE MMI	66
<hr/>		
13.	PASSWORD MANAGER	67
13.1	Password Menu	67
13.2	Create Passwords Menu	68
13.3	List Passwords Menu	68
13.4	Quitting password manager	68

MODIFICATIONS PAGE

Version	DATE	COMMENTS
A	June 1998	ORIGINAL ISSUE
B	December 1998	Updating from MMI release 1.1
C	September 1999	New presentation and updating from MMI release 2.0
D	April 2004	New AREVA presentation Updating from MMI release 3.0
E	June 2004	Adding remote facility
F	September 2004	Minor change, editing for 2 side printing

BLANK PAGE

www.ElectricalPartManuals.com

1. GENERAL

This manual will describe the Man Machine Interface used to configure/test **the PLC 1790/B Revision2**. This update was made necessary due to the obsolescence of some components present on the ELNU board. This has involved material modifications and MMI modification.

It is important to note that this evolution maintains a complete functional compatibility between the PLC1790/B and the PLC 1790/B Revision2 and brings certain improvements to the product.

A link can consist of a PLC 1790/B at one line end and a PLC 1790/B revision2 at the other line end.

Most of the procedures are common to the MS-Windows® platform.

NB : THIS MMI ENABLES TO CONFIGURE/TEST THE PLC 1790/B AND PLC1790 AS WELL : THEREFORE, RÉFÉRENCES TO ELNU AND UBBP BOARDS WHICH EQUIP THESE TYPES WILL BE FOUND IN THIS DOCUMENT.

1.1 Definitions

AF	Audio Frequency
AGC	Automatic Gain Control
INTE	Transit Interface
ITU-T	International Telecommunication Union - Telephony
CCUN	Universal Call Converter Unit (optional)
DSP	Digital Signal Processing
DTE	Data Terminal Equipment
EEPROM	Electrically Erasable Programmable Memory
SF	Sampling Frequency
FSK	Frequency Shift Keying
HF	High frequency
HV	High Voltage
INSU	Supervisory Interface
LF	Low Frequency
LFS or LFS3	Low Frequency Section and its daughter board
CM	Common Mode
DM	Differential Mode
MODAF	High Frequency Modem
NB	Nominal Band
PCB	Printed Circuit Board
PLC	Power Line Carrier
4PSK	Four Phases Shift Keying
ROM	Read Only Memory
SSB	Single Side Band
ST	Sampling Time
TPS	Selective Teleprotection

TABLE 1 – DEFINITION TABLE

1.2 Foreword

Designed to be user friendly Man Machine Interface, enables to perform on the PLC1790/B or PLC1790/B Revision2 equipment :

- configuration of the equipment
- storage of configurations (→ rationalisation of commissioning operations),
- equipment information record, with dates (→ analysis and statistics),
- interactive and user-friendly maintenance,
- printing out of equipment parameters.

The following items are introduced with the PLC1790/B Revision 2:

- Choice of the language of the MMI : english, french or italian
- Management of the MODAF card that assumes the same functions as cards ELNU and INAF
- Extension of the choice of the COM port between 1 and 4 in order to allow the use of USB port associated to COM 3 and 4 ports on PC having in the same time RS232 ports and USB ports.
- Programation of Squelch BF, it is possible to choose the services to block or to maintain during the squelch operation.
- Programation of local PLC alarms (PLC1 alarms) et remote PLC alarms (PLC2 alarms)
- Possibility to invert the transmission band to the carrier in the single channel configuration. For example, for a carrier of 100 kHz, the transmission band can be 96-100 kHz or 100-104kHz. This can facilitate the installation in parallel with equipment already installed.
- Control of the switching frequency of switch of the converter, since the ED05 revision.

1.3 System requirements

The MMI runs on 486 and better PC's, under WINDOWS 95/98, WINDOWS NT or WINDOWS 2000. It needs at least :

- 5 Mbytes available on the hard disk,
- 5 Mbytes of RAM.
- Mouse pointer
- VGA 800x600 Video Display

NOTE: The MMI use is optimal for the following screen resolutions: **1024x768** and **1280x1024**)

- 1 RS232 COM port or 1 USB port.

1.4 Installation of the MMI

- Insert the CD-ROM or the first floppy disk (from the 3) into the disk drive. For security reasons, the MMI should be installed from a back-up copy of the CD-ROM or the floppy disks supplied.
- Run **setup.exe** (for floppy disk : from <Menu><Run> in the program manager : A:setup),
- Follow on-screen instructions

1.5 **MMI Operator Mode**

The MMI is an integrated environment, using standard WINDOWS tools and procedures.

Since this document only describes operator modes specific to the MMI, an operator not familiar with WINDOWS should refer to the user manual for this environment.

1.6 **Running the MMI**

The MMI is started from the **PLC1790_ML** icon in the **PLC1790 MMI** group of program itself in the **Areva T&D** group of programs.

2. MAIN SCREEN

The main screen has 4 functional zones :

2.1 Title bar

The title bar displays the name of the MMI and its current version at the top of the screen.

2.2 Menu bar

The operator issues commands via standard WINDOWS menus, displayed according to the current user level, which is in turn determined by the password entered by the operator.

2.3 State bar

The state bar has one line showing functional information

2.4 Working and dialogue zone

Many commands are also issued in dialogue boxes using standard WINDOWS tools.

Screens display used in examples herein are subject to change without notice.

3. BASE WINDOW

3.1 Menu bar

Under the main window, the operator has the capability to open the following windows:



FIGURE 1 – MAIN WINDOW

3.1.1 Tools menu

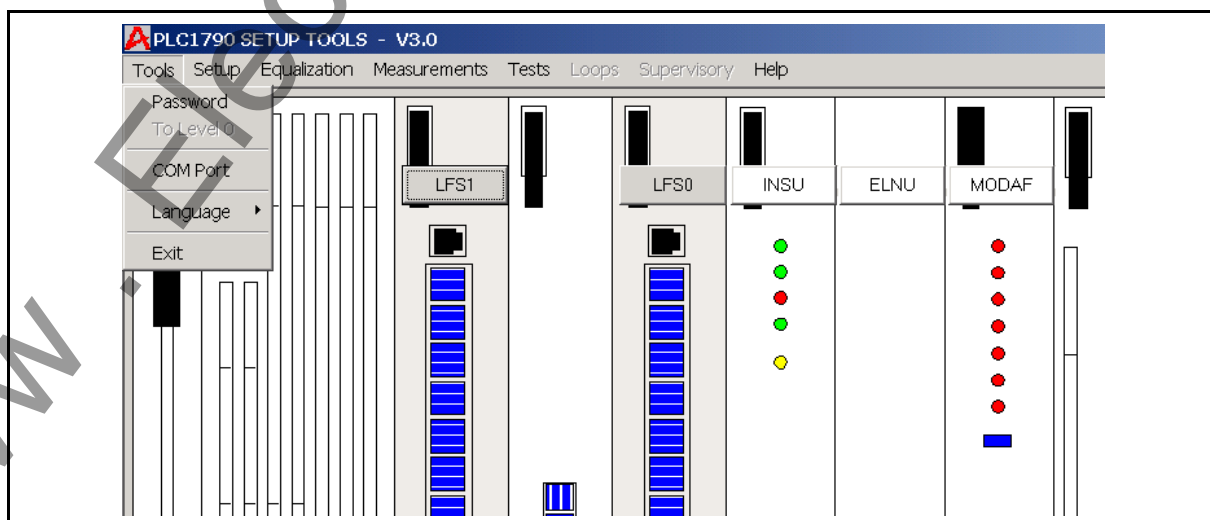

FIGURE 2 – TOOLS MENU AND SUB-MENUS

PASSWORD

- Always enabled
- Opens the window which allows to enter the access password

LEVEL

- Enabled for user level > 0
- Sets the user level to 0

COM PORT

- Always enabled
- Opens the window which allows to change the PC communication port (COM1 to COM4)

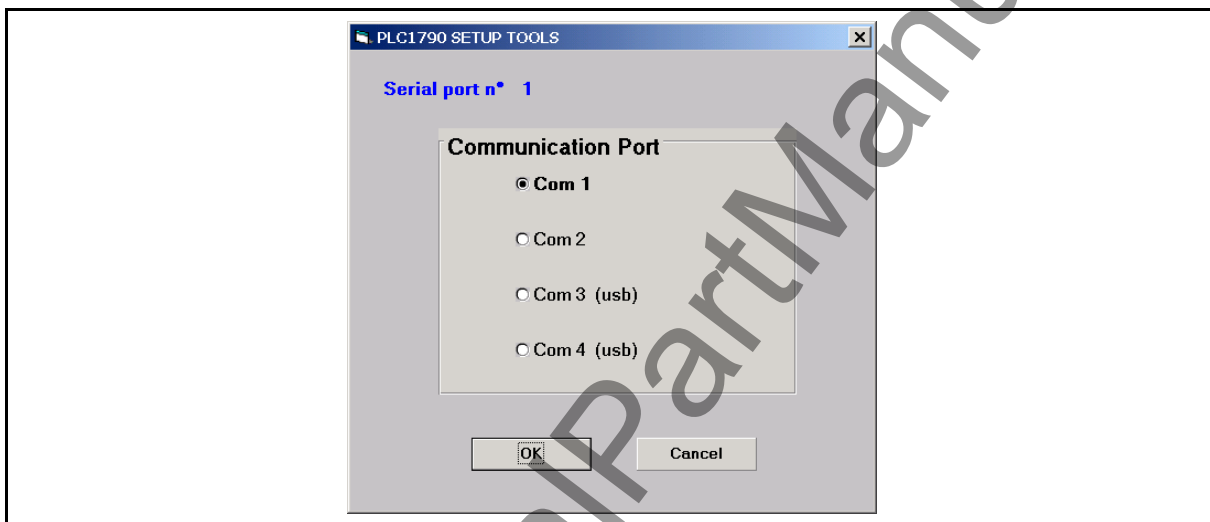

FIGURE 3 – COM PORT CHOICE WINDOW

LANGUAGE

The user can choose at any moment one the 3 following languages

- English
- French
- Italian

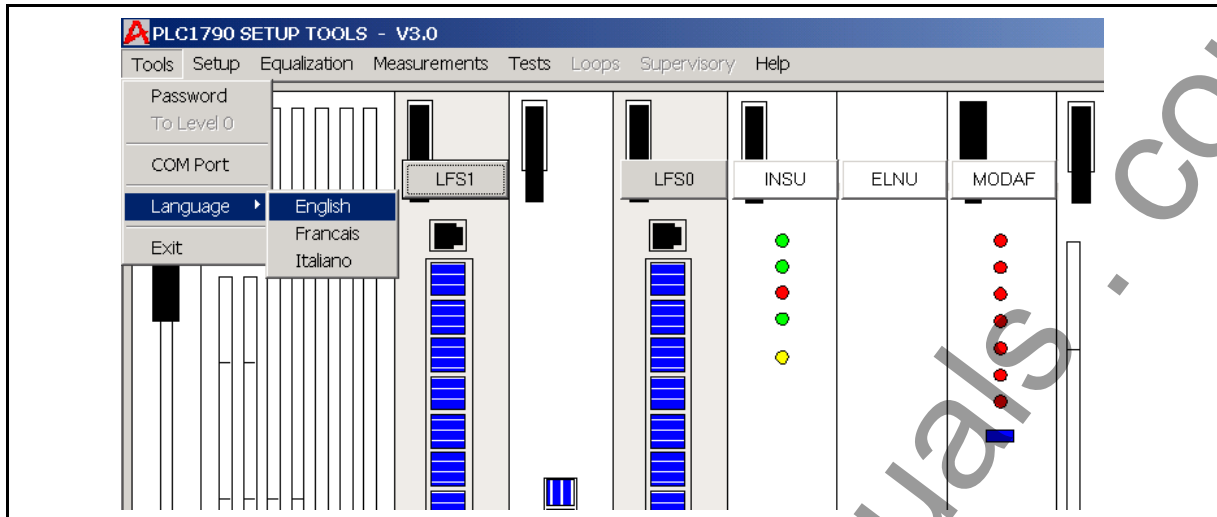

FIGURE 4 – LANGUAGE CHOICE SUB-MENU

EXIT

- Always enabled
- Allows Exiting the PLC1790/B Revision 2 Interface. This menu item and the **Close** menu item of the Base window Control-box are **the only ways to quit the application.**

3.1.2 Setup

Menu and sub-menus always enabled:

- MODAF sub-menu : opens the **MODAF Board Settings** window
- ELNU : sub-menu : opens the **ELNU Board Settings** window
- UBBP sub-menu : opens the **UBBP Boards Settings** window
- LFS sub-menu : opens the **LFS Boards Settings** window
- INSU sub-menu : opens the **INSU Boards Settings** window

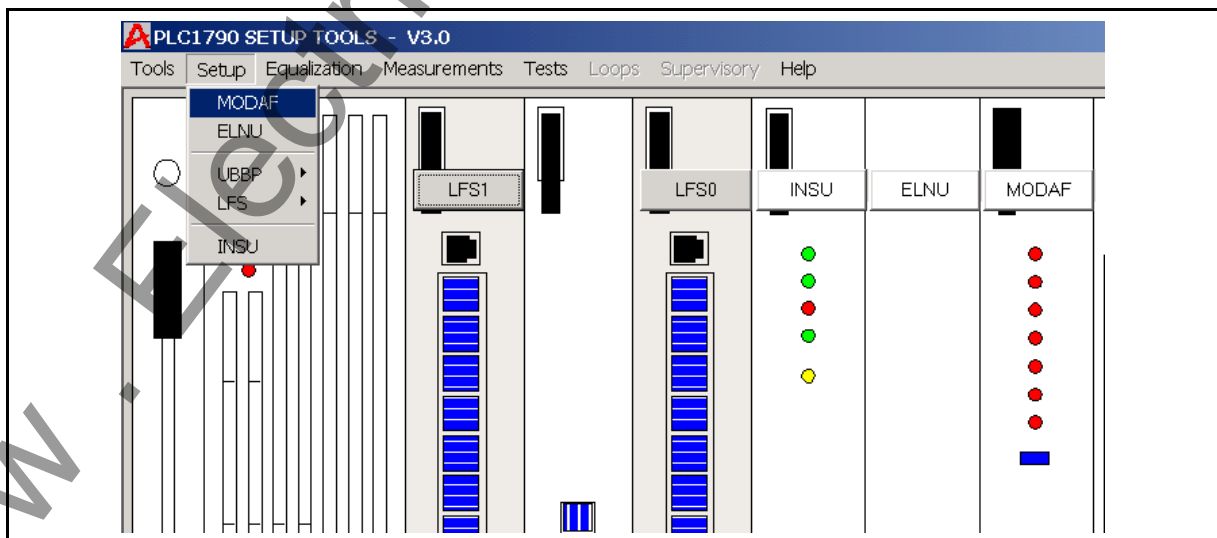

FIGURE 5 – SETUP MENU

3.1.3 Buttons on the image of the PLC 1790

The buttons on the boards has the same function as the previous menu items and are always enabled:

- MODAF button: opens the **MODAF Board Settings** window
- ELNU button: opens the **ELNU Board Settings** window
- LFS button: opens the **LFS Boards Settings** window
- INSU button: opens the **INSU Boards Settings** window

3.1.4 Equalization

Menu and sub-menus enabled for user level > 0 :

- **LOCAL OR REMOTE AF BOARD** sub-menu : opens the **Low Frequencies Equalizer** window of UBBP board (PLC 1790) or LFS board (PLC 1790/B and PLC 1790/B R2).

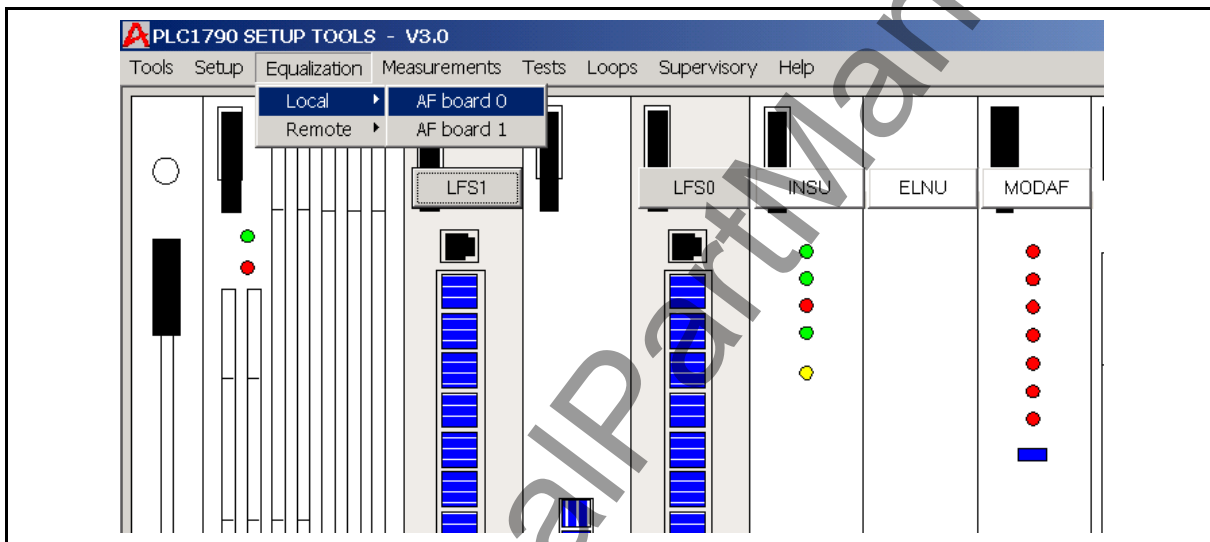

FIGURE 6 – EQUALIZATION MENU AND SUB-MENUS

3.1.5 On line measurements

No sub-menus

- Always enabled
- Opens the **MODAF/ELNU Board Measurements** window

3.1.6 Tests

Menu and sub-menus enabled for user level > 0

- **AF BOARD (0/1)** sub-menu : opens the **AUDIO FREQUENCIES TESTS** window of UBBP board (PLC 1790) or LFS board (PLC 1790/B R2). This menu is available for local or remote equipment.
- **4PSK** sub-menu : opens the **4PSK MODEM TEST** window (for the MTU 1200 Bps under LFS3 only).

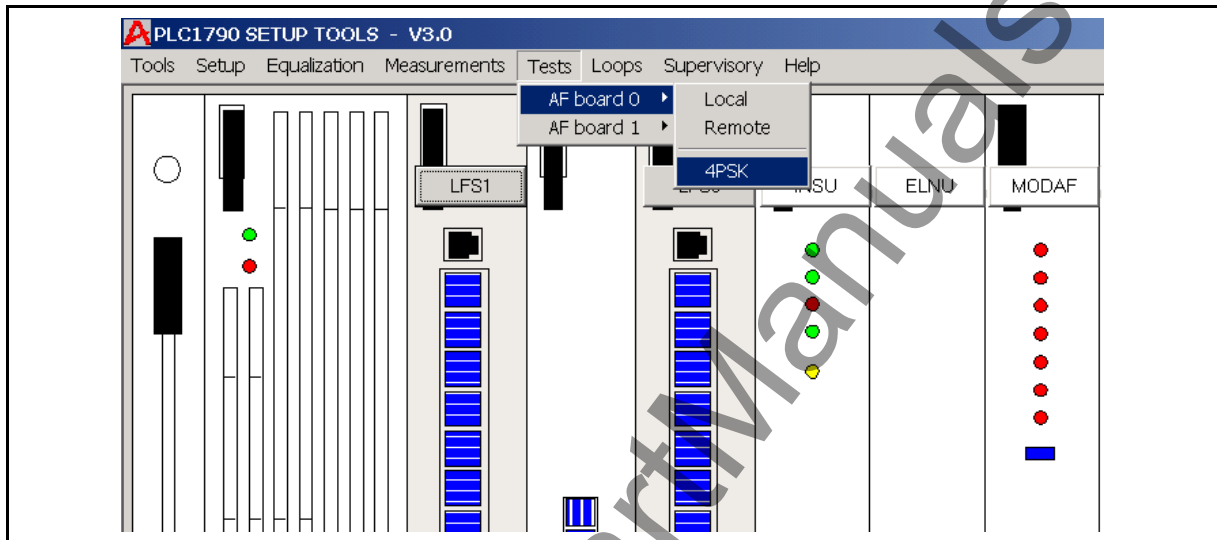

FIGURE 7 – TEST MENU AND SUB-MENUS

Each sub-menu opens a question box :

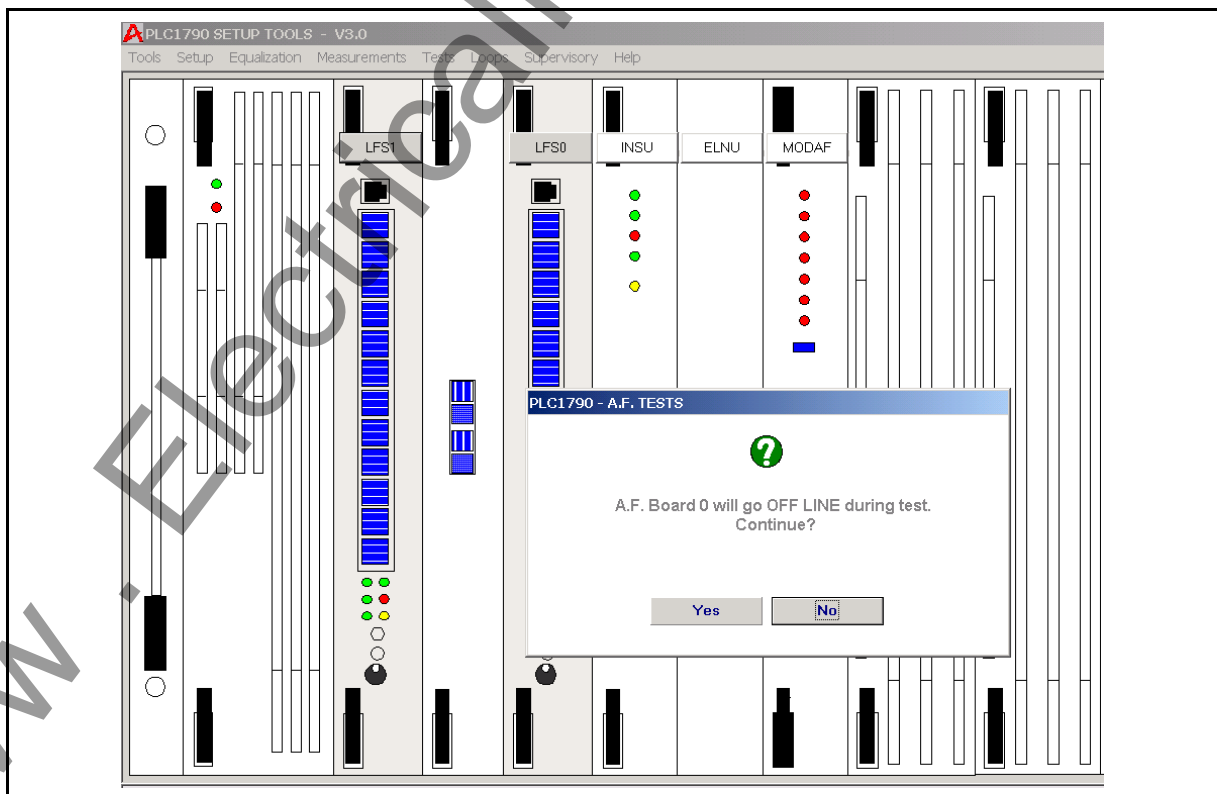

FIGURE 8 – AFTER TEST MODE REQUESTED

The answer **Yes** :

- sets the AF board on Test mode,
- opens the Audio Frequencies Tests window

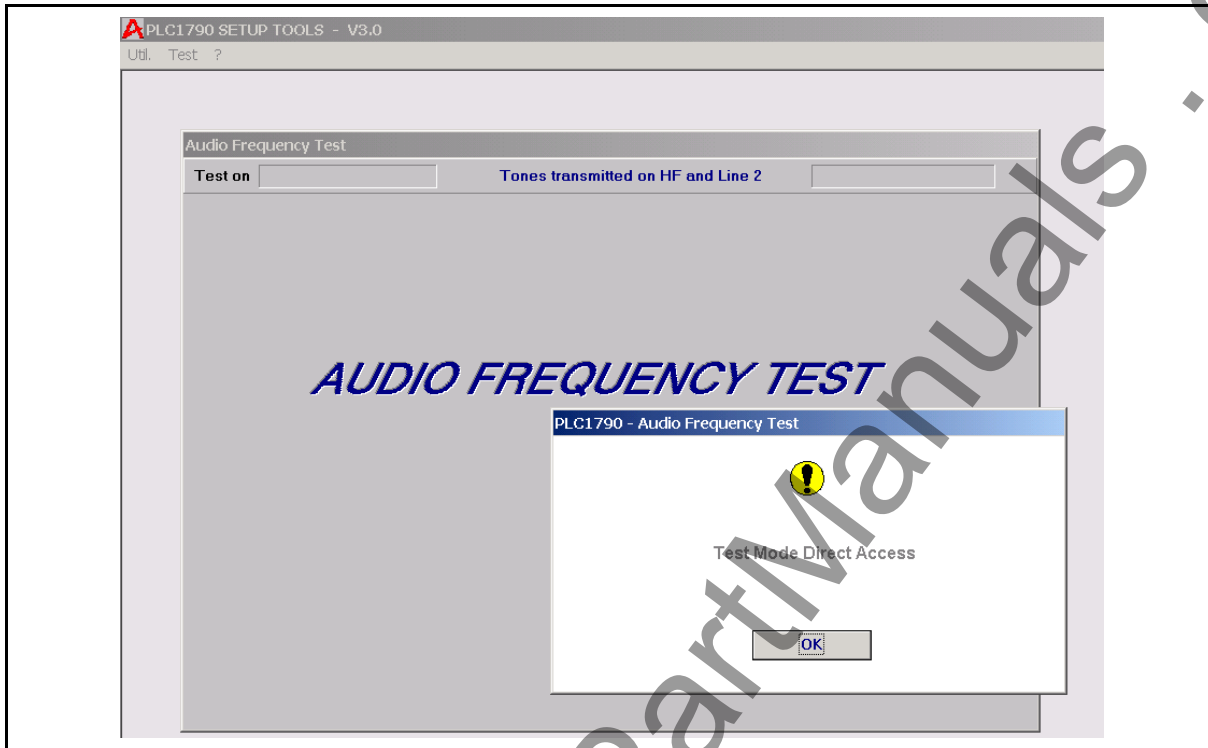

FIGURE 9 – AFTER TEST MODE REQUESTED ON PLC ALREADY ON TEST MODE

3.1.7 Loop

Menu and sub-menus enabled for user level > 0

LOCAL

- Always enabled
- Opens the **Local Loop Test** window

REMOTE

- Enabled when LOCAL sub-menu disabled
- Opens the **Remote Loop Test** window.

3.1.8 Supervisory

Menu and sub-menus enabled for user level > 0

- Opens the Inputs / Outputs Supervisory and Command window

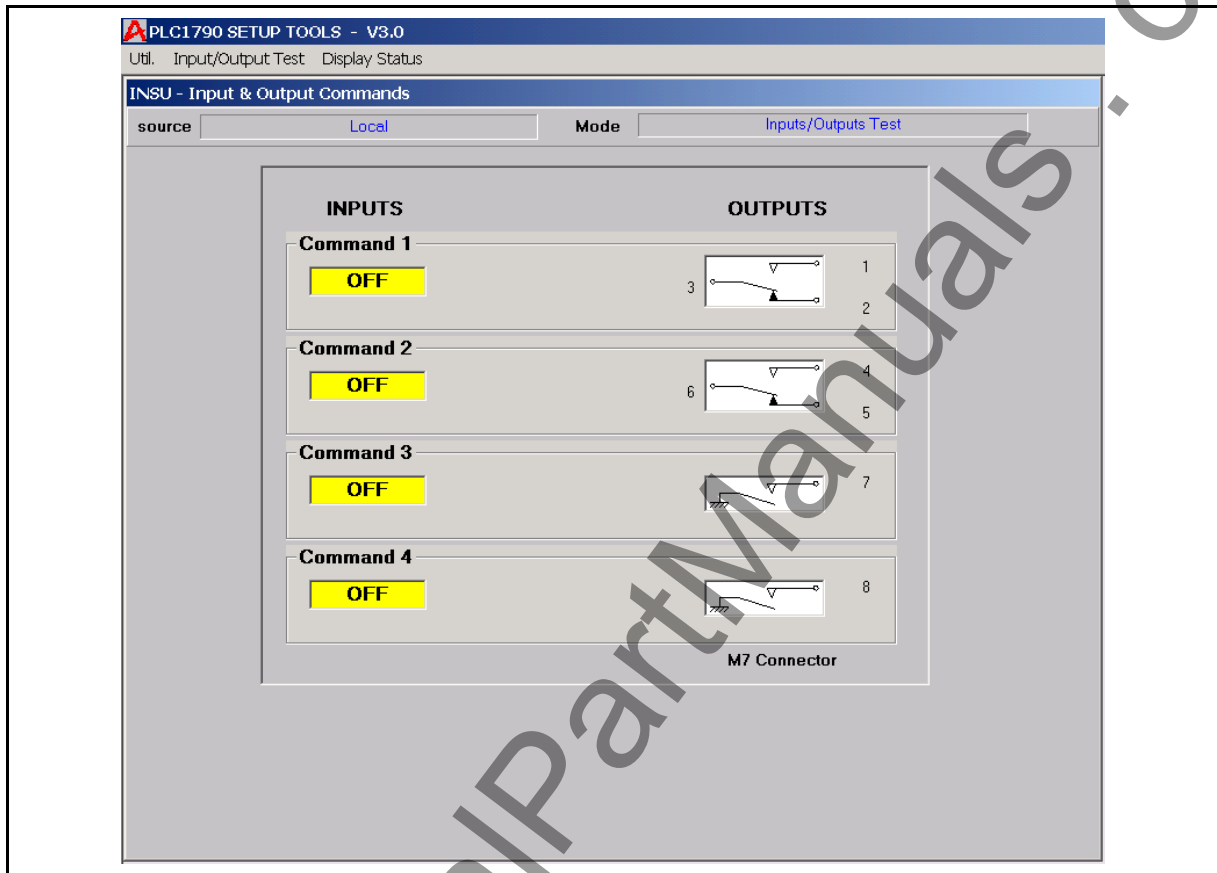

FIGURE 10 – SUPERVISORY MENU

3.1.9 Help

- Always enabled
- Includes following commands :

The LFS "Help" menu includes an additional item which is the level table (See §.6.1.6).

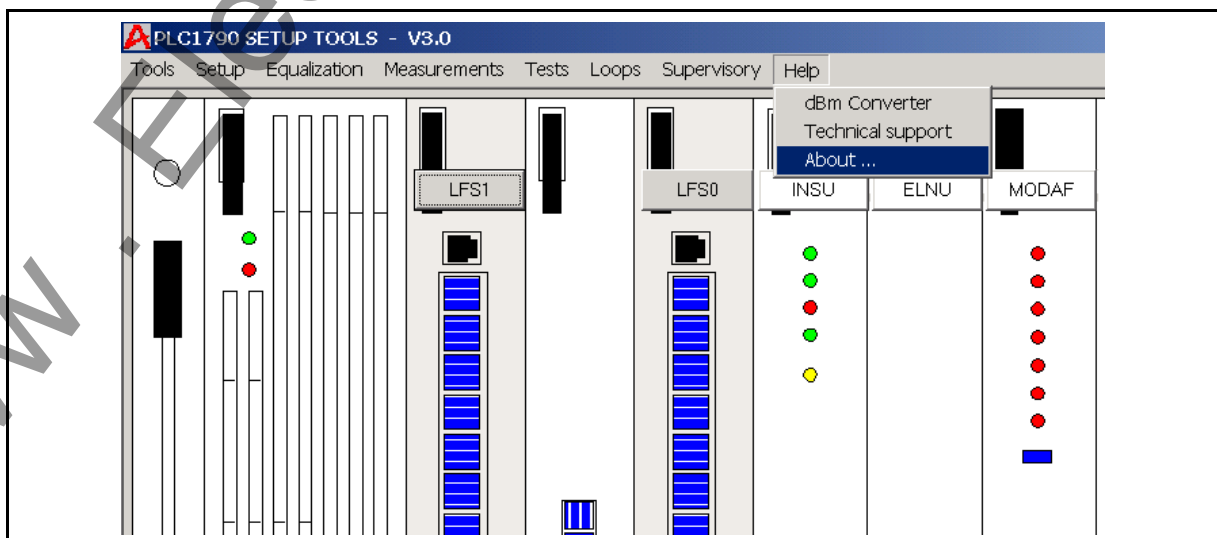

FIGURE 11 – HELP MENU AND SUB-MENUS

3.1.9.1 LEVEL TABLE

Single channel equipment

ACCESS	MODE	LF LEVEL		HF LEVEL							
		dBm Nominal		10 W		20 W		40 W		80 W	
		IN	OUT	dBm	V	dBm	V	dBm	V	dBm	V
CARRIER				22	3.45	25	4.87	28	6.88	31	9,72
SPEECH	2 Wires	0	-7	30	8.66	33	12.23	36	17.28	39	24,41
	4 Wires	-3.5	-3.5	30	8.66	33	12.23	36	17.28	39	24,41
LINE 2		-28	-28	20	2.74	23	3.87	26	5.46	29	7.72
DATA		-14	-14	20	2.74	23	3.87	26	5.46	29	7.72
MTU Internal Modem	50 Bd			20	2.74	23	3.87	26	5.46	29	7.72
	100 Bd			23	3.87	26	5.46	29	7.72	32	10.90
	200 Bd			26	5.46	29	7.72	32	10.90	35	15.40
	600 Bd			28	6.88	31	9.72	34	13.73	37	19.39
	1200 Bd			30	8.66	33	12.23	36	17.28	39	24,41
SIGNALING	FSK			20	2.74	23	3.87	26	5.46	29	7.72
	On / Off			32	10.90	35	15.40	38	21.75	41	30,73

Double channel equipment

ACCESS	MODE	LF LEVEL		HF LEVEL							
		dBm Nominal		10 W		20 W		40 W		80 W	
		IN	OUT	dBm	V	dBm	V	dBm	V	dBm	V
CARRIER				16	1.73	19	2.44	22	3.45	25	4.87
SPEECH	2 Wires	0	-7	24	4.34	27	6.13	30	8.66	33	12.23
	4 Wires	-3.5	-3.5	24	4.34	27	6.13	30	8.66	33	12.23
LINE 2		-28	-28	14	1.37	17	1.94	20	2.74	23	3.87
DATA		-14	-14	14	1.37	17	1.94	20	2.74	23	3.87
MTU Internal Modem	50 Bd			14	1.37	17	1.94	20	2.74	23	3.87
	100 Bd			17	1.94	20	2.74	23	3.87	26	5.46
	200 Bd			20	2.74	23	3.87	26	5.46	29	7.72
	600 Bd			22	3.45	25	4.87	28	6.88	31	9.72
	1200 Bd			24	4.34	27	6.13	30	8.66	33	12.23
SIGNALING	FSK			14	1.37	17	1.94	20	2.74	23	3.87
	On / Off			26	5.46	29	7.72	32	10.90	35	15.40

TABLE 2 – LEVEL TABLE FOR LFS BOARD

The above level table are given for information, including the usual setup levels. These values can be modified depending of site needs. The carrier level and signaling level depends directly on the equipment power, only a fine tune can be applied.

3.1.9.2 DBM Converter

An utility is provided with the MMI.

This utility allows to convert for a selected impedance :

- dBm Volt
- dBm Watt
- Volt Watt

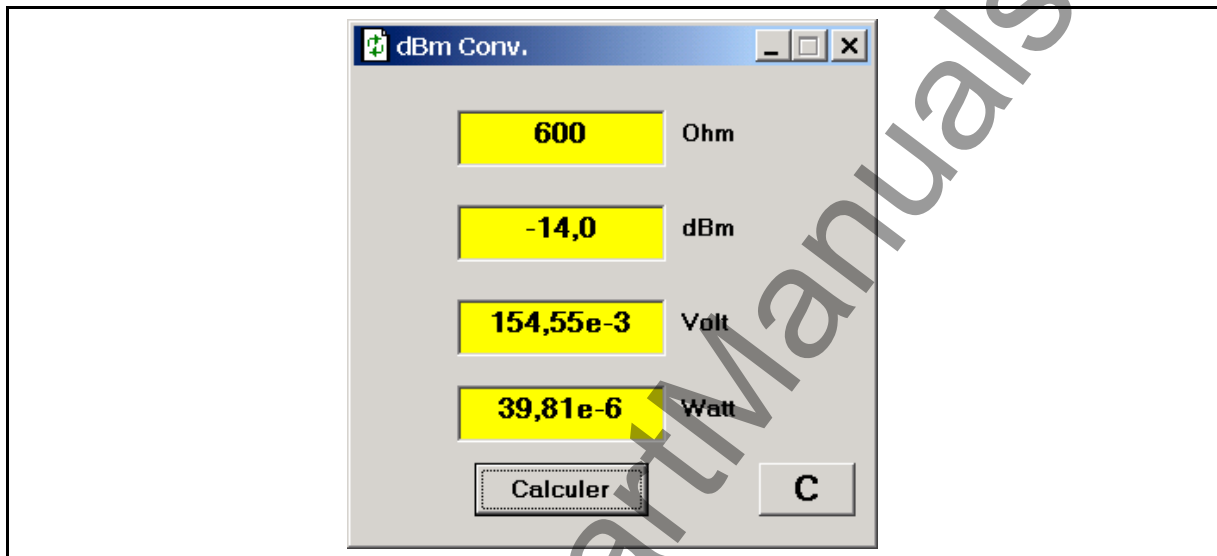

FIGURE 12 – dBm CONVERTER UTILITY

3.2 State bar

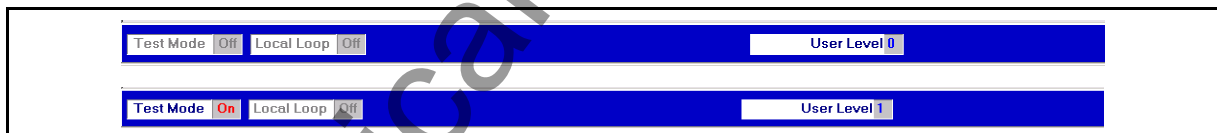

FIGURE 13 – STATE BAR (2 EXAMPLES)

3.2.1 Local Loop status

- Disabled for Local Loop Off
- Displayed in red for Local Loop On

3.2.2 Test Mode

It displays the nature of the last command given by the user, and not the actual Test Mode

- Disabled for no low frequency board in Test Mode
- Displayed in red for at least one low frequency board in Test Mode. In this case, a click on **Test Mode** (crosshair shape mouse pointer) opens a window displaying the current test mode :

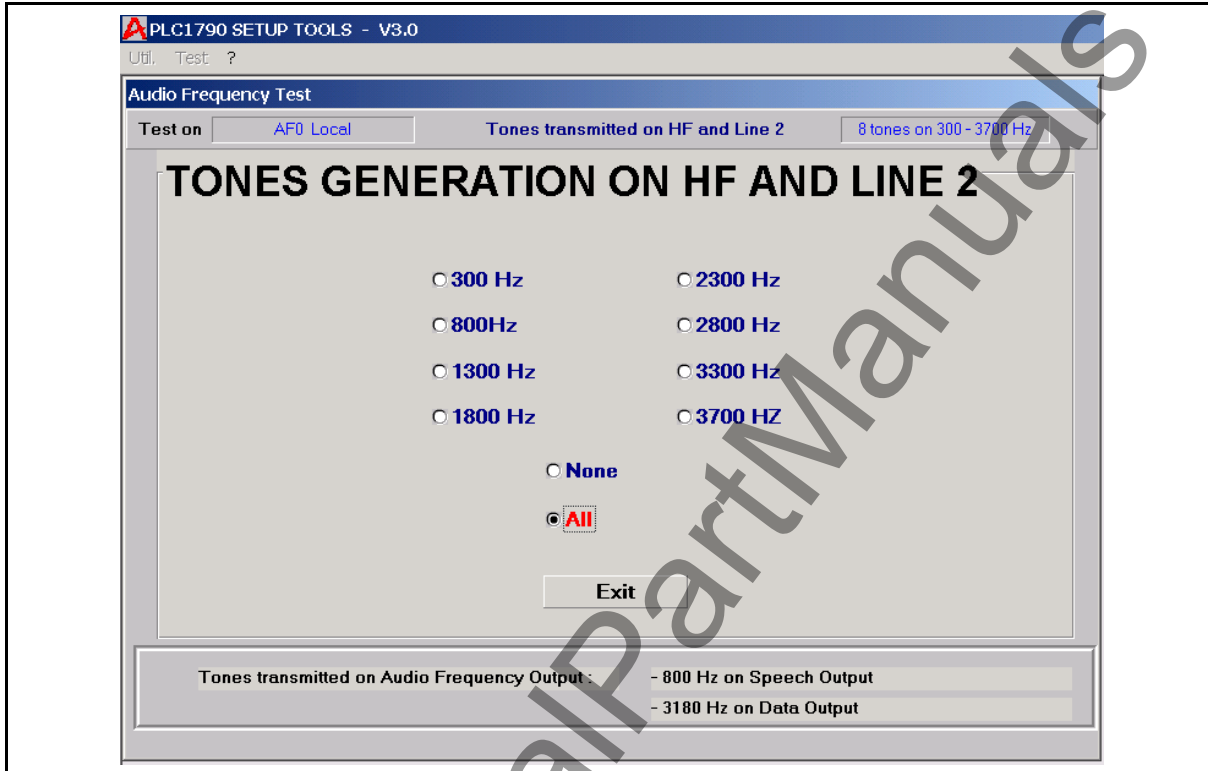

FIGURE 14 – TEST MODE

3.2.3 User Level

User level number (0 or 1)

In order to change the user level from 0 to 1 enter in UTIL/PASSWORD command, and then insert your password that you have already created with the Password Manager Program.(See § 13.2).

4. MODAF BOARD SETUP

4.1 Start configuration

Click on MODAF button or select SETUP command on standard menu bar and click MODAF field in order to display the **MODAF Board Settings** window.

Two tabs called “Carriers and Power” and “Advanced” allow to set the main parameters of the PLC 1790/B R2 equipment. Each tab displays a by-default configuration when creating a new MODAF board setting.

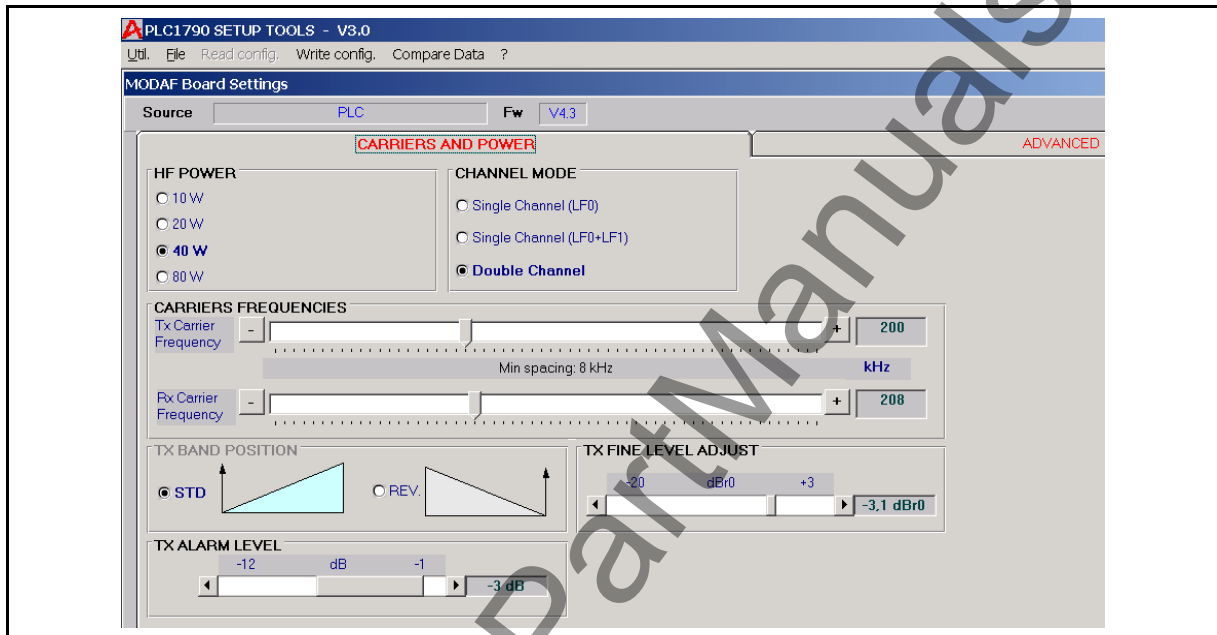

FIGURE 15 – MODAF SETUP WINDOW. CARRIERS AND POWER TAB.

The “**Carriers and Power**” tab allows to set the following parameters:

- **HF Power** : high frequency peak envelope power of the PLC equipment,
- **Channel mode**: Single (LF0), Single (LF0+LF1) or double channel configuration. The PLC 1790 equipment allows to use up two UBBP (PLC1790) or LFS boards to configure one 0 ÷ 4 KHz communication channel in order to meet specific requirements such as up to 2 RS232 data channel interfaces, up to 6 telegraph channels interfaces, transit towards more than one low frequency transmission media,...
- **Tx band position** : **Standard** or **Reversed**
- **Carriers frequencies**: Tx and Rx carrier frequencies which can be programmed from 40 up to 496 KHz at 1 KHz step,
- **Tx Fine Level Adjust** in order to have the planned HF carrier transmission levels,
- **Tx Alarm Level** which is consistent to the programmed HF power.

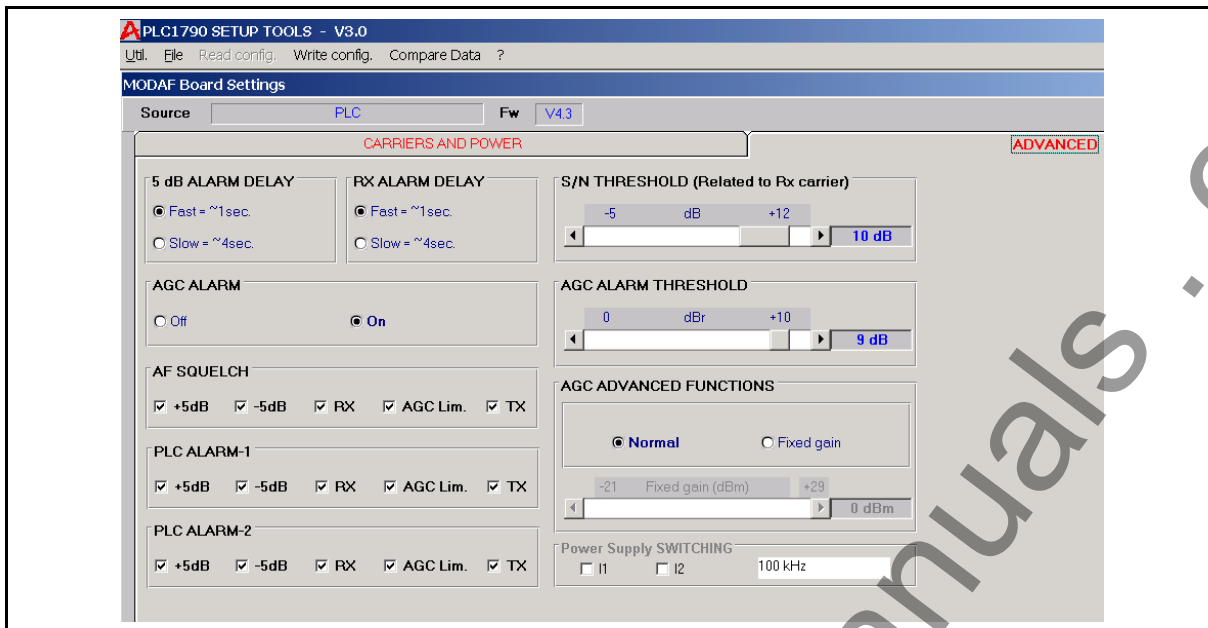

FIGURE 16 – MODAF SETUP WINDOW. ADVANCED TAB

The “Advanced” tab allows to set the following parameters:

- **5dB Alarm Delay:** Fast (about 1sec) or Slow (about 4sec)
- **Rx Alarm Delay:** Fast (about 1sec) or Slow (about 4sec)
- **S/N Threshold (Related to Rx carrier)** alarm level referring to the nominal speech level. Between -5 and +12 dB
- **AGC Alarm** and **AGC Alarm Threshold:** the Agc Alarm Threshold frame area is enabled only when the AGC Alarm “On” option has been selected.

It defines a delta in dBr, that will reduce the AGC range at each side. The range reduction is done by shifting its limits symmetrically starting from its extremities. The new upper threshold is equal to the maximum value (29 dB) minus the delta and the new low threshold is equal to the minimum value (-21 dB) plus the delta. So this determines two new thresholds for the AGC limit alarm. The default value of this delta is 0 and its maximum value is 10.

Example:

If we choose a delta of 6 dBr, the range of the MODAF will be inside the interval $-15 \leftarrow \rightarrow 23$ dB, instead of $-21 \leftarrow \rightarrow 29$ dB.

In these condition the AGC limit Alarm will be activated, if, during its evolution, the gain takes a value $\bullet -11$ or $\bullet 19$ dB.

- **AGC Advanced Functions** allows to choose the speed of AGC gain adjustment. If the “Fixed gain” option is selected (normally not used) the area allowing the choice of the gain is activated.
- **AF Squelch** : Low frequency squelch to disable the low frequency Rx services. The squelch is full-configurable for five criteria: +5dB, -5dB, Rx, AGC limit and Tx. In case of double PLC channels the squelch criteria will affect both channels. By default all the criteria are selected.
- **PLC Alarm-1** to enable the local PLC alarms : they are full-configurable for five criteria : +5db, -5db, Rx, AGC limit and Tx (as for AF squelch). In case of double PLC channels the PLC Alarm-1 criteria will affect both channels. By default all the criteria are selected.
- **PLC ALARM-2** to enable the alarms of the remote PLC : they are also configurable for the same five criteria as for PLC Alarm-1. In case of double PLC channels the PLC Alarm-1 criteria will affect both channels.

4.2 Menus

4.2.1 Tools

Similar to the Base window Tools menu except for the EXIT sub-menu which allows only to come back to the Base window and not to quit the application.

4.2.2 File

NEW

- Enabled when no configuration is displayed on screen
- Displays a by-default configuration

OPEN

- Enabled when no configuration is displayed on screen
- Allows to display an existing configuration file by opening the WINDOWS standard dialogue box

CLOSE

- Enabled when a configuration is displayed on screen
- Closes the configuration displayed on screen
- Opens a dialogue box when the configuration has been modified and not saved

SAVE

- Enabled when a configuration is displayed on screen
- Allows to save the configuration file displayed on screen by opening the WINDOWS standard dialogue box

SAVE AS

- Enabled when a configuration is displayed on screen
- Allows to save the configuration displayed on screen in a new file by opening the WINDOWS standard dialogue box

PRINT

See § 12.1

FONTS

See § 12.2

4.2.3 Read Setup

This menu item is always disabled with MODAF board because the configuration is automatically read when the board is successfully connected and is read and displayed.

4.2.4 Write Setup

No sub-menu

- Enabled for user level > 0 and when a configuration is displayed on screen
- Writes the configuration displayed on screen in the MODAF board. A confirmation message is displayed at the end of the operation :

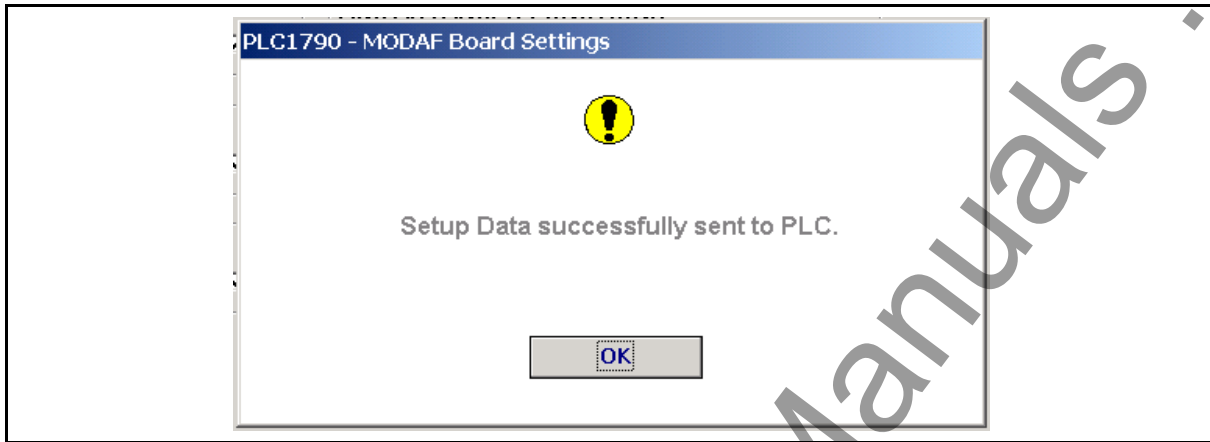

FIGURE 17 – MODAF DATA DOWNLOAD WINDOW

4.2.5 Compare data

- No sub-menus
- Enabled for user level > 0 and when a configuration is displayed on screen
- Compares the MODAF board configuration to the configuration displayed on screen. This configuration is the result of either a read setup or a file opening.
- Opens the comparison window :

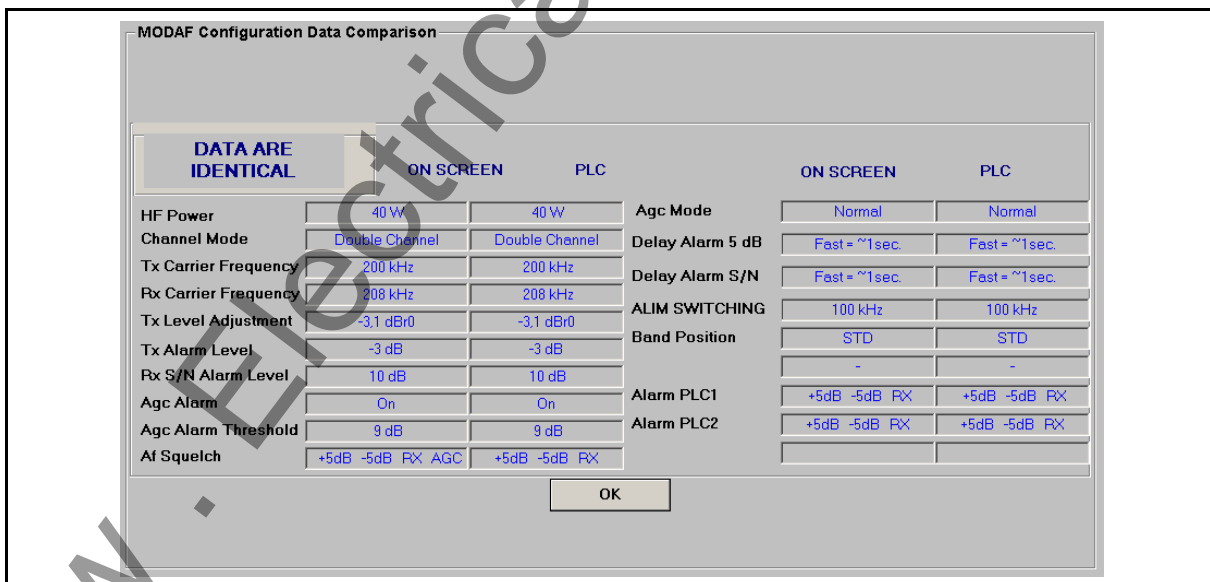

FIGURE 18 – MODAF DATA COMPARISON WINDOW

4.2.6 Help

See § 3.1.9

4.3 State bar

Located under the menu bar

4.3.1 Source

Origin of on-screen data:

- **None** for no data on screen
- **PLC** for reading the PLC
- **C:\<DIR>\<FILENAME.EXT>** for a file

4.3.2 FW field

MODAF firmware version.

5. ELNU BOARD SETUP

5.1 Start configuration

Click on ELNU button the the Base window or select SETUP command on standard menu bar and click ELNU field in order to entr **ELNU Board Settings** window.

It displays a by-default settings when creating a new ELNU configuration.

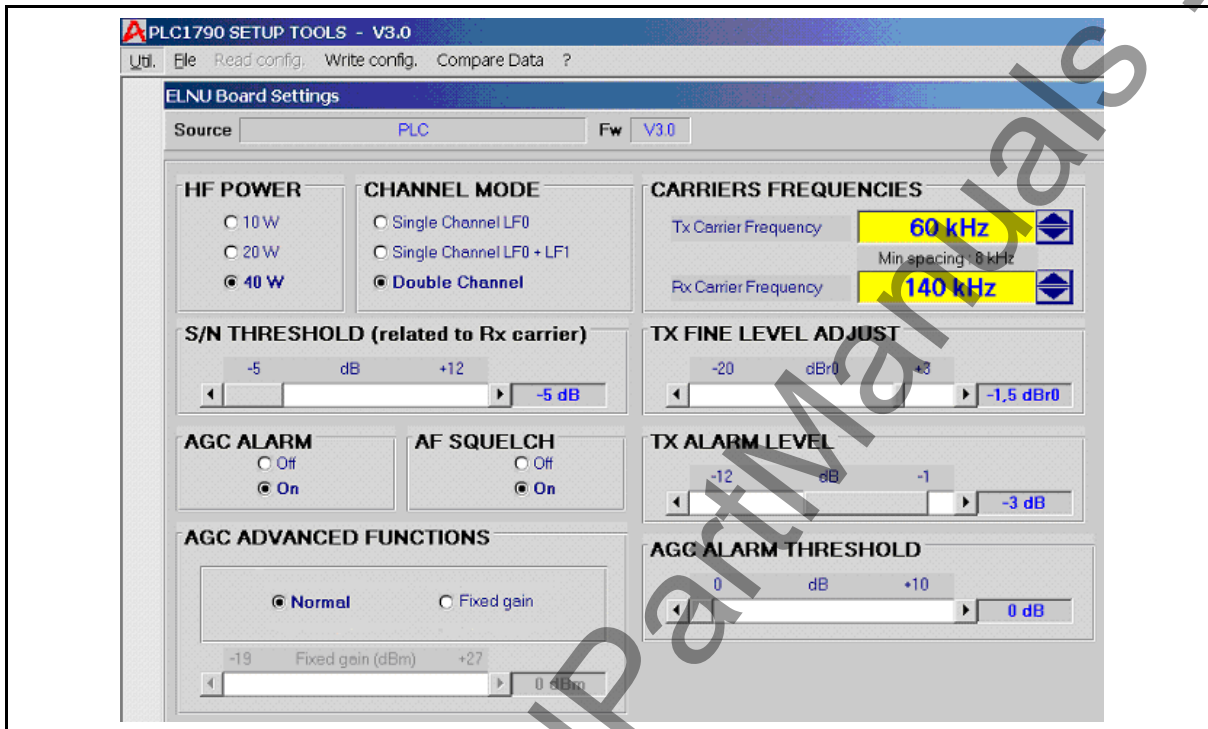

FIGURE 19 – ELNU SETUP WINDOW

5.2 Menus

5.2.1 Util

Similar to the Base window TOOLS menu (§ 3.1.1), except for the EXIT sub-menu which allows only to come back to the Base window and not to quit the application.

5.2.2 File

The following **ELNU Board Settings** window allows to set the main parameters of the PLC 1790/B R2 equipment such as :

- High frequency peak envelope power of the PLC equipment (HF Power)
- Single or double channel configuration. The PLC 1790 equipment allows to use up two UBBP (PLC1790) or LFS boards to configure one 0 ÷ 4 KHz communication channel in order to meet specific requirements such as up to 2 RS232 data channel interfaces, up to 6 telegraph channels interfaces, transit towards more than one low frequency transmission media,...
- TX and RX carrier frequencies which can be programmed from 40 up to 496 KHz at 1 KHz step
- TX fine level adjust in order to have the planned HF transmission levels
- TX alarm level which is consistent to the programmed HF power
- S/N alarm level referring to the nominal speech level

- AGC alarm and relative threshold which define the upper and lower limit referring to AGC range. The Agc Alarm Threshold frame area is enabled only when the AGC Alarm “On” option has been selected.

It defines a delta in dBr, that will reduce the AGC range at each side. The range reduction is done by shifting its limits symmetrically, starting from its extremities. The new upper threshold is equal to the maximum value (27 dB) minus the delta and the new low threshold is equal to the minimum value (-19 dB) plus the delta. So this determines two new thresholds for the AGC limit alarm. The default value of this delta is 0 and its maximum value is 10.

- Low frequency squelch to disable the low frequency services. In case of double PLC channels the squelch criteria will affect both channels.

NEW

- Enabled when no configuration is displayed on screen
- Displays a by-default configuration

OPEN

- Enabled when no configuration is displayed on screen
- Allows to display an existing configuration file by opening the WINDOWS standard dialogue box

CLOSE

- Enabled when a configuration is displayed on screen
- Closes the configuration displayed on screen
- Opens a dialogue box when the configuration has been modified and not saved

SAVE

- Enabled when a configuration is displayed on screen
- Allows to save the configuration file displayed on screen by opening the WINDOWS standard dialogue box

SAVE AS

- Enabled when a configuration is displayed on screen
- Allows to save the configuration displayed on screen in a new file by opening the WINDOWS standard dialogue box

PRINT

See § 12.1

FONTS

See § 12.2

5.2.3

Read Setup

No sub-menus

Reads and displays the ELNU board configuration

5.2.4 Write Setup

- No sub-menus
- Enabled for user level > 0 and when a configuration is displayed on screen
- Writes the configuration displayed on screen in the ELNU board. A confirmation message is displayed at the end of the operation :

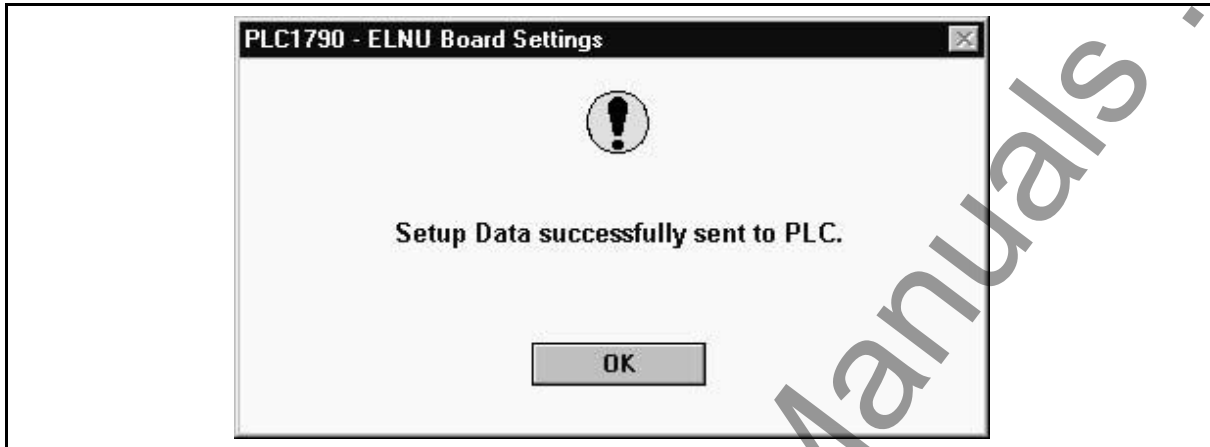

FIGURE 20 – ELNU DATA DOWNLOAD WINDOW

5.2.5 Compare data

- No sub-menus
- Enabled for user level > 0 and when a configuration is displayed on screen
- Compares the ELNU board configuration to the configuration displayed on screen. This configuration is the result of either a read setup or a file opening.
- Opens the comparison window :

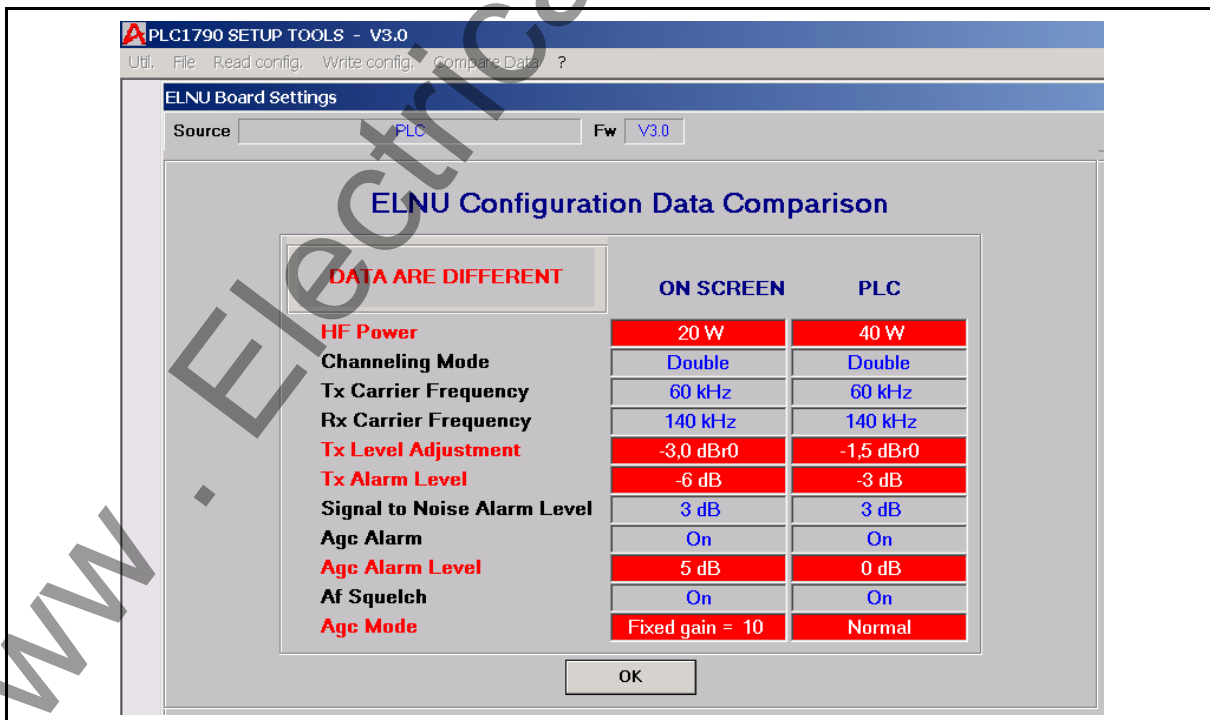

FIGURE 21 – ELNU DATA COMPARISON WINDOW

5.2.6 Help

See § 3.1.9

5.3 State bar

Located under the menu bar

5.3.1 Source

Origin of on-screen data:

- **None** for no data on screen
- **PLC** for reading the PLC
- **C:\<DIR>\<FILENAME.EXT>** for a file

5.3.2 Fw field

ELNU firmware version

5.4 Working window particularity

In the frame area called **AGC ALARM**, if the option button is :

- ON => **Agc Alarm Threshold** frame area is enabled
- OFF => **Agc Alarm Threshold** frame area is disabled

6. UBBP BOARDS SETUP (PLC1790)

The **UBBP board settings** window allows to attribute the low frequency band to each service such as speech, signalling, telegraph interface, MTU data interface.

The Party-Line function allows to define the path for each service, which can be addressed towards HF line, LINE 2 or both.

The LINE 2 can be used to interface an external Teleprotection equipment which uses the PLC as transmission media to connect the remote Teleprotection equipment.

The window shows a "Service Overlap" warning message to the operator when the Telegraph channel and MTU use the same frequency band.

A second warning message "Telegraph service filter disabled" is present on the window when the filter resource is used to define a selective transit function towards LINE 2 and not to limit the Telegraph service band.

Teleprotection window is enabled when Teleprotection function is programmed on LINE 2 in the Board sharing window. In this case, LINE 2 interface is automatically routed towards HF interface.

Teleprotection window allows to set the boost criteria at + 6 dB in order to increase the S/N ratio of the Teleprotection transmission command.

To avoid any overload, the low frequency services can be suppressed independently such as Speech, Signaling, Telegraph. An attenuator can adapt the RX levels towards the local Teleprotection equipment in a range from 0 dB up to -20 dB.

6.1 Menu bar

Select SETUP command on standard menu bar and click UBBP in order to enter **UBBP Boards Settings** procedure.

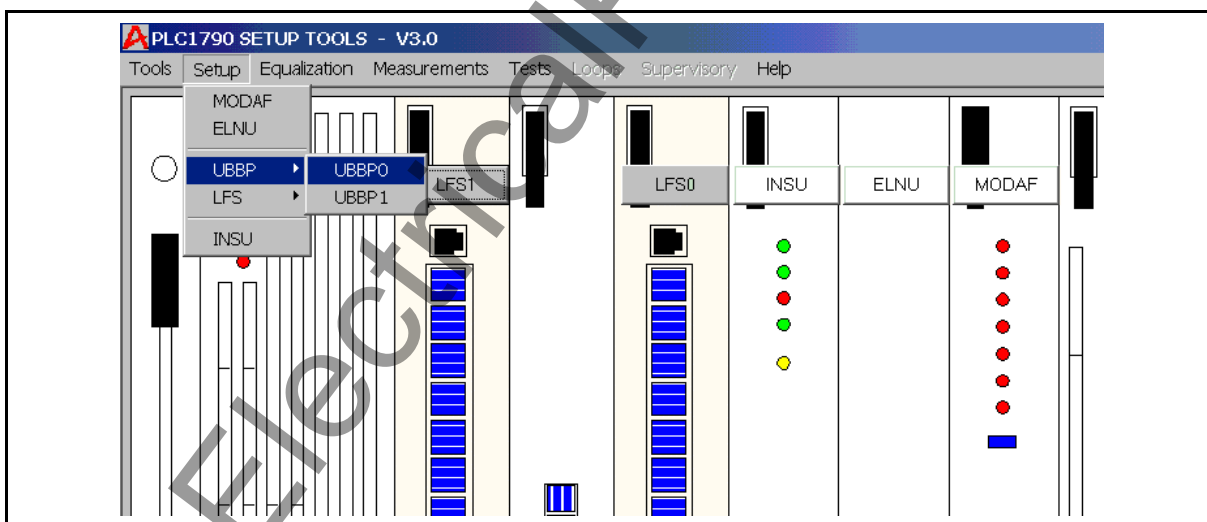

FIGURE 22 – UBBP SETUP MAIN WINDOW

6.1.1 File

Similar to FILE of *ELNU Board Settings* window (§ 5.2.2)

6.1.2 Read Setup

LOCAL SUB-MENUS :

- Enabled for user level > 0
- Reads and displays the local UBBP board configuration.

REMOTE Sub-menus :

- Enabled for user level > 0
- Reads and displays the remote UBBP board configuration.

6.1.3 Write Setup

LOCAL SUB-MENUS : LOCAL

- Enabled for user level > 0 and when a configuration is displayed on screen
- Writes the configuration displayed on screen in the UBBP board. A confirmation message is displayed at the end of the operation.

6.1.4 Help

See § 3.1.9

6.2 State bar

Located under the menu bar

6.2.1 Source

See § 5.3.1

6.2.2 Fw field

UBBP firmware version.

6.3 Working window

Two-tab folder :

- **Band Sharing** tab : always enabled

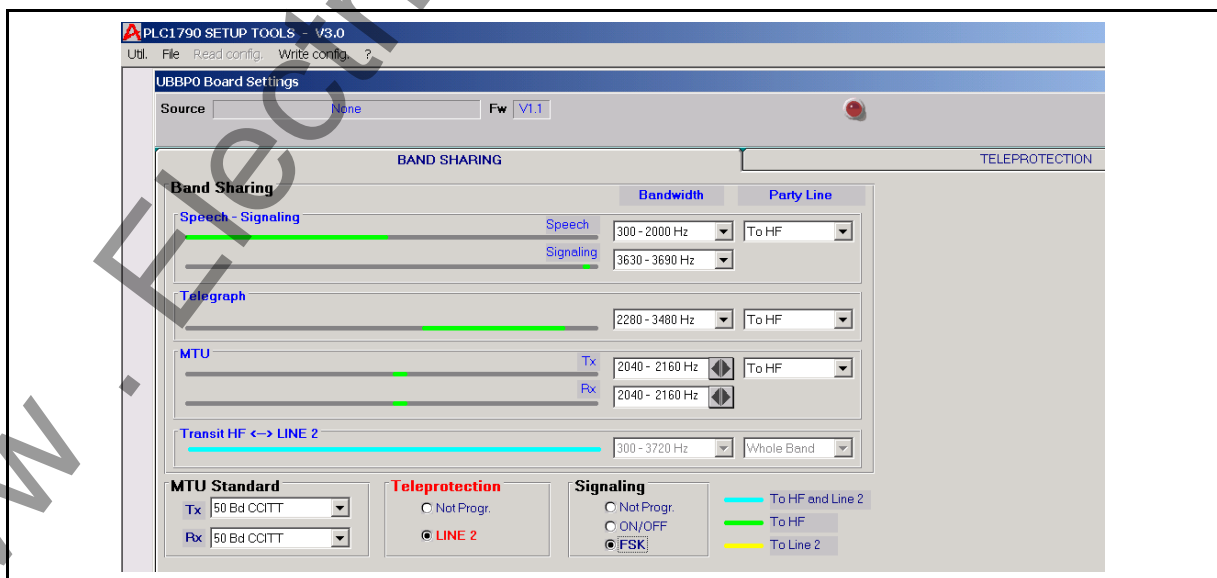

FIGURE 23 – UBBP BAND SHARING WINDOW

TELEPROTECTION TAB:

- enabled for Option Button LINE 2 in **Teleprotection** frame area of **Band Sharing** tab
- disabled for Option Button NOT PROGR in **Teleprotection** frame area of **Band Sharing** tab



FIGURE 24 – UBBP TELEPROTECTION SETUP FUNCTIONS

7. LFS BOARDS SETUP WINDOW

Select SETUP command on standard menu bar and click LFS board sub-menu in order to enter **LFS Boards Settings** procedure.

7.1 Menu bar

7.1.1 Tools

Similar to Tools of **UBBP Board Settings** window (§ 5.2.1).

7.1.2 File

Similar to FILE of **UBBP Board Settings** window (See § 5.2.2)

The LFS board setting window allows :

- to attribute the low frequency band to each service such as speech, signaling, telegraph interface, MTU data interface. (Band Sharing window strictly similar to the correspondent UBBP window : see § 6.3)
- to adjust the input output levels for speech (2 wires or wires), telegraph channel, LINE 2 interface (Levels window)
- to activate advanced functions for speech, signaling, MTU modem and LINE 2 equalizer (Advanced functions window)
- to program the interface towards an external Teleprotection equipment connected to LINE 2 (Teleprotection window is specific to the LFS board. (see § 6.3.3)

7.1.3 Read Setup

Similar to READ SETUP of **UBBP Boards Settings** window (See § 6.1.2)

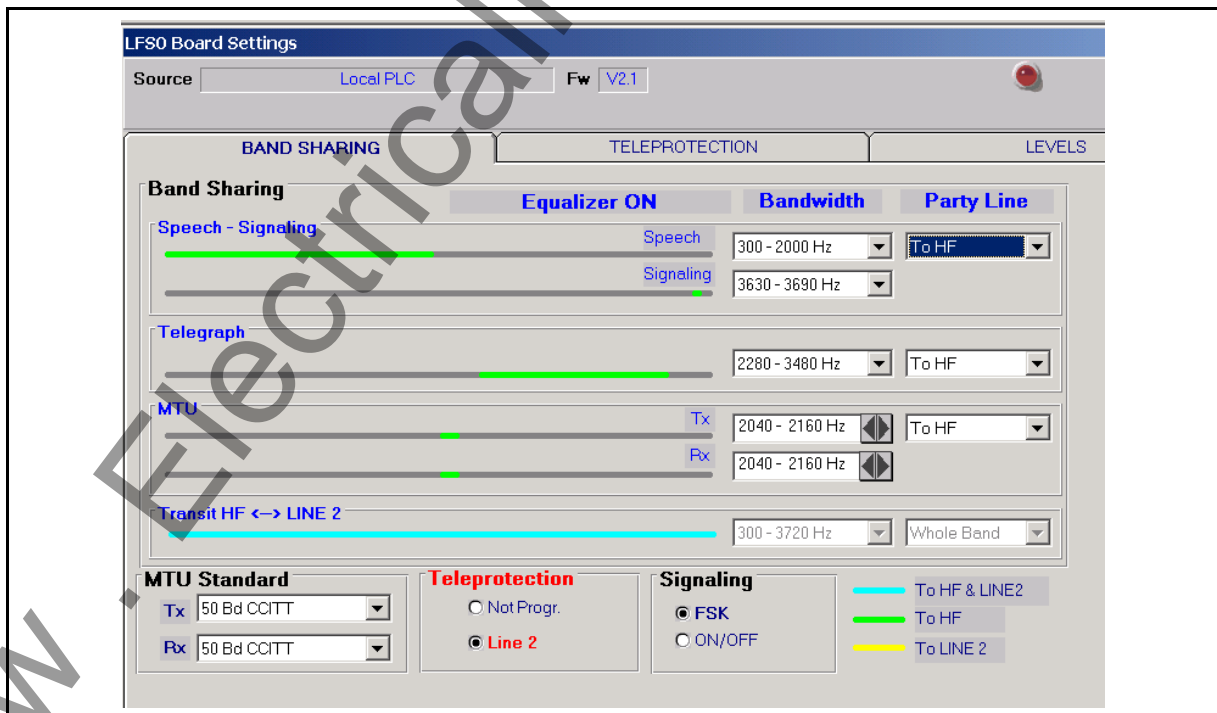

FIGURE 25 – LFS BAND SHARING WINDOW

7.1.4 Write Setup

Similar to WRITE SETUP of **UBBP Boards Settings** window (See § 6.1.3)

7.1.5 Help

The LFS "**Help**" menu includes an additional item, which is the level table.

This table makes the connection between LF level of any access and the HF level according to a 10W, 20W, 40W or 80W equipment.

For other commands See § 3.1.9

7.2 State bar

Located under the menu bar

7.2.1 Source

See § 5.3.1

7.2.2 Fw field

LFS firmware version

7.3 Working window

Four-tab folder :

- **Band Sharing** tab : always enabled - strictly similar to the correspondent tab of the UBBP window (see § 6.3)
- **Teleprotection** tab : see § 6.3.3)
- **Levels** tab : always enabled
- **Advanced functions** tab : always enabled

7.3.1 Levels tab

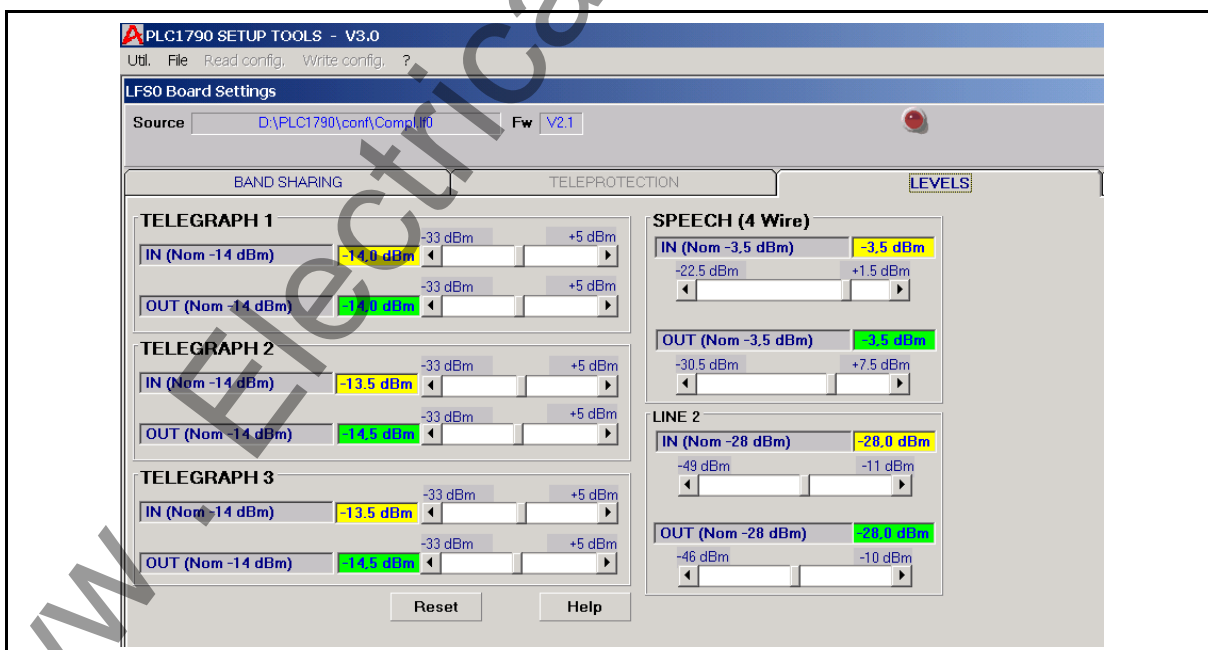

FIGURE 26 – LFS LEVELS ADJUSTMENT

The level tab allows to set the input /output Low Frequency and Line 2 levels for Speech and Telegraph services.

When the **Speech** interface is programmed AUTO, we suppose the PLC is interfaced to the local PAX in two wires and the input output levels are referred to the 2 wires interface.

MTU level is automatically adjusted according to the programmed baud rate

L2 Attenuators shows the level on the input and output accesses, for a HF level according to -14dBm on the LF data channel.

7.3.2 Advanced Functions tab

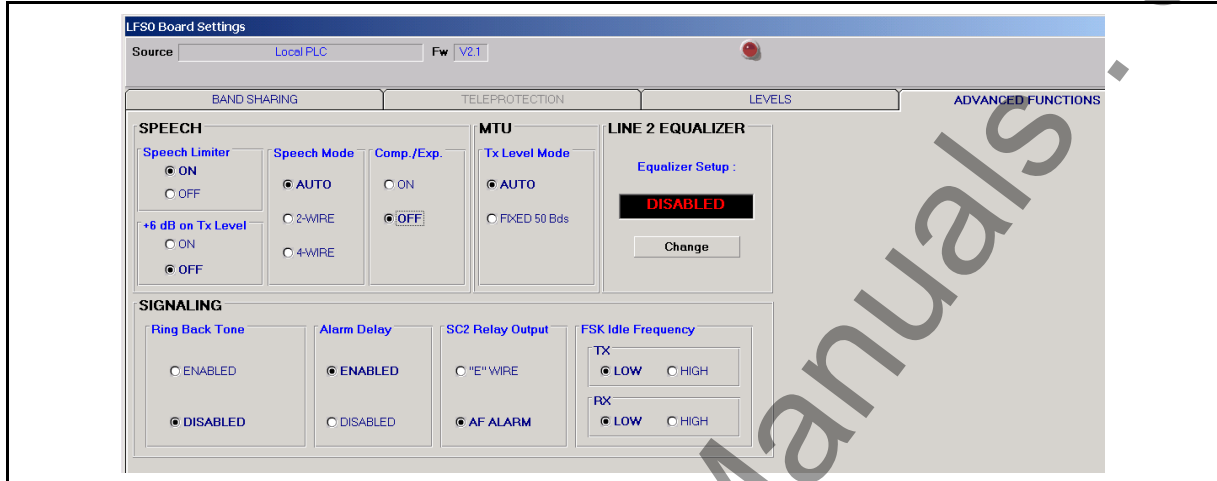

FIGURE 27 – LFS ADVANCED FUNCTIONS

Some particular facilities are accessible under the ADVANCED FUNCTIONS sub menu of LFS board setting.

SPEECH

Speech limiter

The Speech LIMITER function can be set in order to avoid an overload of HF equipment.

Select ON to use the LIMITER function on the speech transmission.

Select OFF to skip the LIMITER function

Speech mode

The Speech Termination can be setup by the configuration or an external command, for 2 WIRES or 4 WIRES interface or in AUTO mode, depending on the mode of connection to the autocommutator (the criteria status received from the local PABX).

Three different choices are available:

- | | |
|---------|--|
| AUTO | the 2 / 4 wires changeover is managed by SPEECH 2/4 WIRES CHANGEOVER CRITERIA; by default it is set up for 4 WIRES |
| 2 WIRES | Fix setting on 2 WIRES with the AF hybrid on internal load |
| 4 WIRES | Fix setting on 4 WIRES |

Comp./Exp.

The Compandor/Expandor function could be turned ON /OFF.

MMI selection available only with LFS-3 board (strap SZ20 3-4 Open), and hardware selection with LFS (strap SZ20).

MTU MODEM/TX LEVEL MODE

The internal modem MTU adjusts the transmission level according to the baud rate. Choose AUTO to keep this performance or FIXED 50 BAUD to set the output level at the 50 Baud level.

SIGNALING

Ring Back tone

This function is particularly useful when the CCUN board is equipped and programmed with BC - central battery. In this case when the LFS board receives an incoming call, it sends back to the remote LFS a 425 Hz tone during the whole duration of the call.

Alarm Delay

On FSK type signaling, whenever the received level drop of 6 dB or more the AF alarm is triggered. Choose **ENABLED** to set a delay of one second, to avoid false alarm due to a teleprotection command, or **DISABLED** to return immediately the alarm.

SC2 Relay Output

Two different signals can drive the relay SC2: choose

- AF ALARM to return a secondary AF alarm output
- "E" WIRE to return the RX signaling on free voltage contact.

FSK Idle Frequency

Set the idle frequency of the FSK type signaling. Select :

- LOW to transmit or receive the lower frequency of the signaling -
i.e. $F_c = 3660 \text{ Hz} \Rightarrow F_{IDLE} = 3630 \text{ Hz}$
- HIGH to transmit or receive the higher frequency of the signaling -
i.e. $F_c = 3660 \text{ Hz} \Rightarrow F_{IDLE} = 3690 \text{ Hz}$

LINE 2 EQUALIZER

Line 2 analogue input is provided with independent line equalizer. Select CHANGE field to enter the setup menu:

Fifteen different curves are available. Click with the mouse on the chart to toggle between the different curves. Press RETURN to accept the selection and return to the previous menu.

Whenever the TPS is programmed on LINE 2, the cable equalizer is automatically disabled.

Click on CHANGE in the **L2 Equalizer** frame to display the **L2 Equalizer Setup** window :

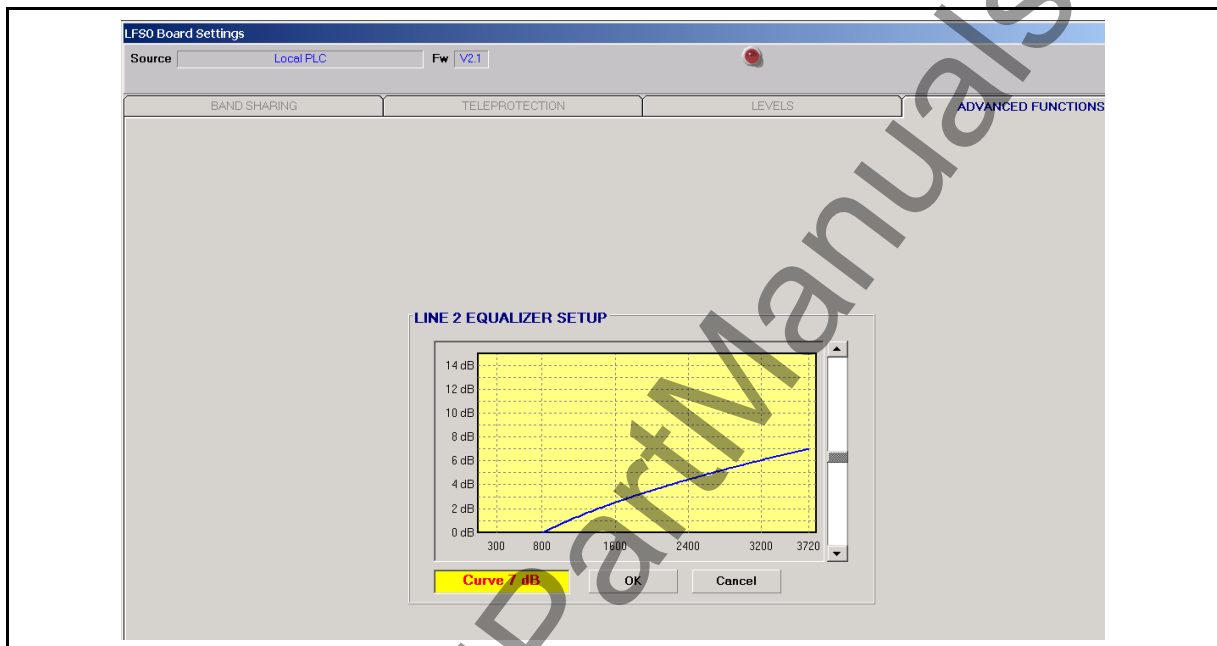

FIGURE 28 – LFS LINE-2 EQUALIZER

- OK button : come back to **Advanced functions** tab with the new curve
- Cancel button : come back to **Advanced functions** tab with no change

7.3.3 Teleprotection TAB

- enabled for Option Button LINE 2 in **Teleprotection** frame of **Band Sharing** tab
- disabled for Option Button NOT PROGR in **Teleprotection** frame of **Band Sharing** tab

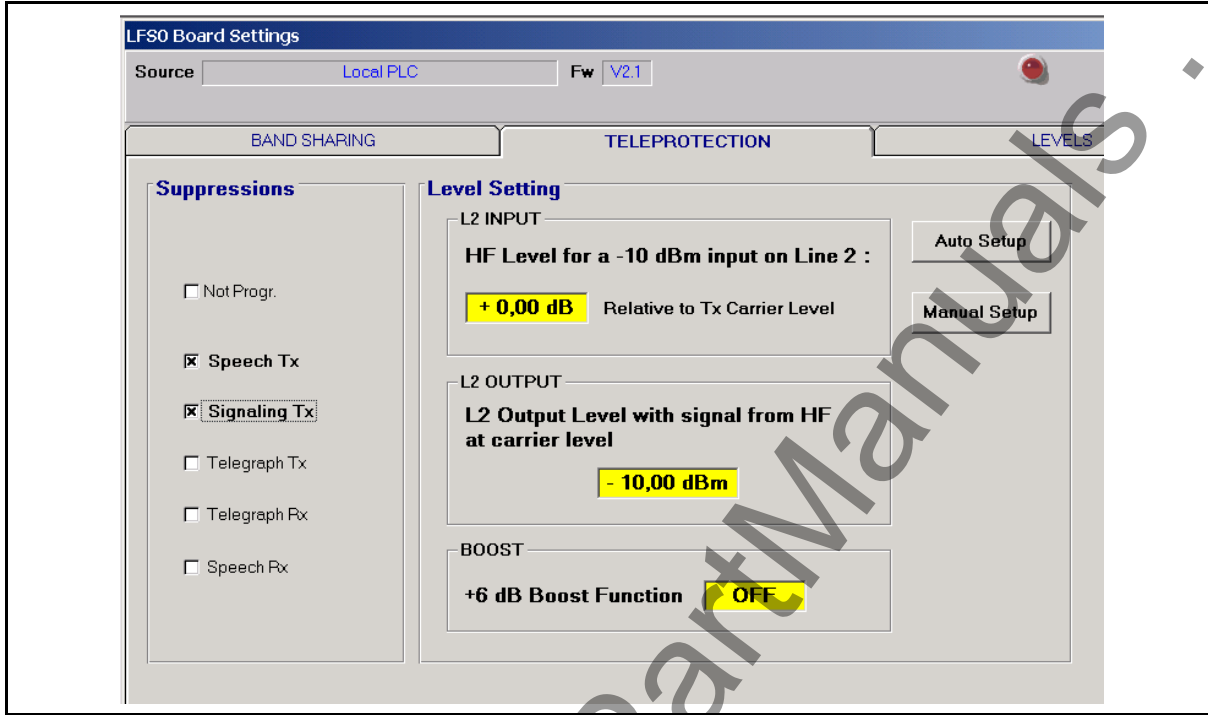

FIGURE 29 – LFS TELEPROTECTION PARAMETERS

Only suppression services can be selected on this window. Level modification can be set through "Auto Setup" or "Manual Setup" buttons.

Showned levels are in accordance with the current line 2 attenuators setting.

Auto Setup :

The Automatic set-up button, select a default configuration :

- Signaling as guard frequency
- LF input and output teleprotection level set to -12 dBm
- Boost function OFF

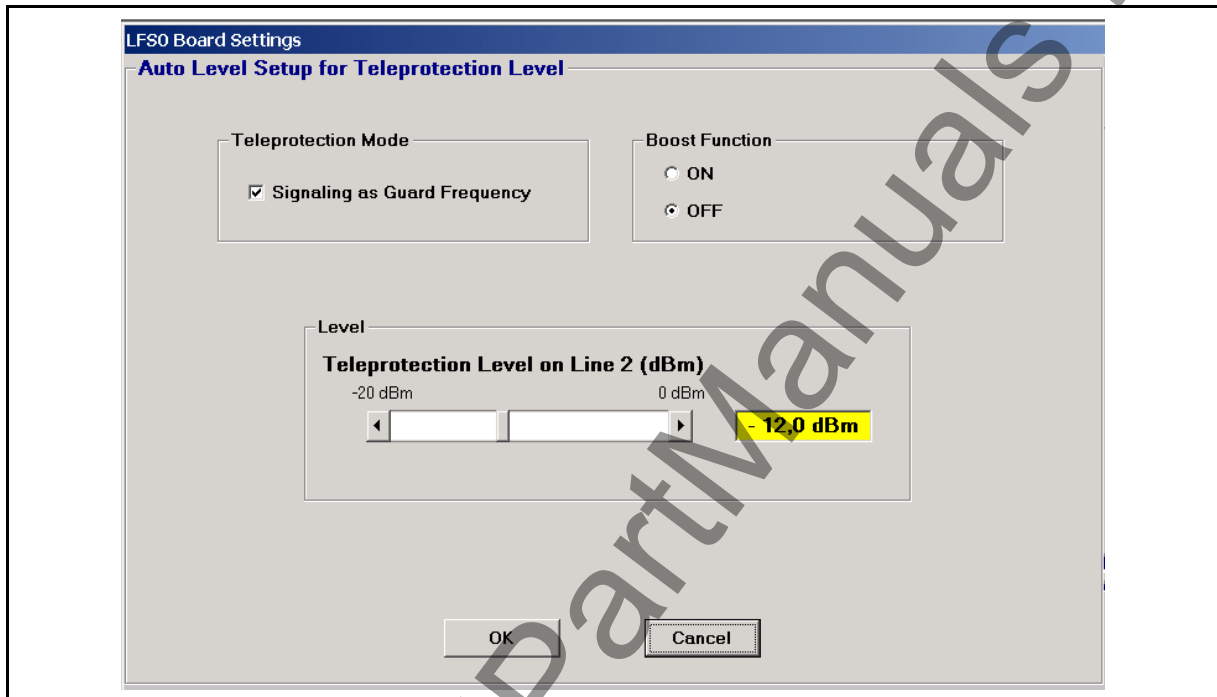

FIGURE 30 – AUTOMATIC SETUP TELEPROTECTION (LFS)

Parameters can be modified :

Guard frequency as signaling

This option allows to automatically adjust input and output line 2 attenuators, in order to get the command frequency level as guard frequency level. This in relation with the wished LF teleprotection level.

If this option is not ticked, two setup must be done. The LF teleprotection level as well as the HF level expressed in dB in relation to the carrier level.

Boost Function

When this function is ON, the HF level from line 2 is 6 dB raised-up on "Tx suppression service LF" or "Rx suppression service LF" activation.

Manual Setup :

The Manual set-up button, allows to set separate input and output teleprotection levels.

Attenuators can be adjusted independently, the HF level is showed in dB in accordance with carrier level.

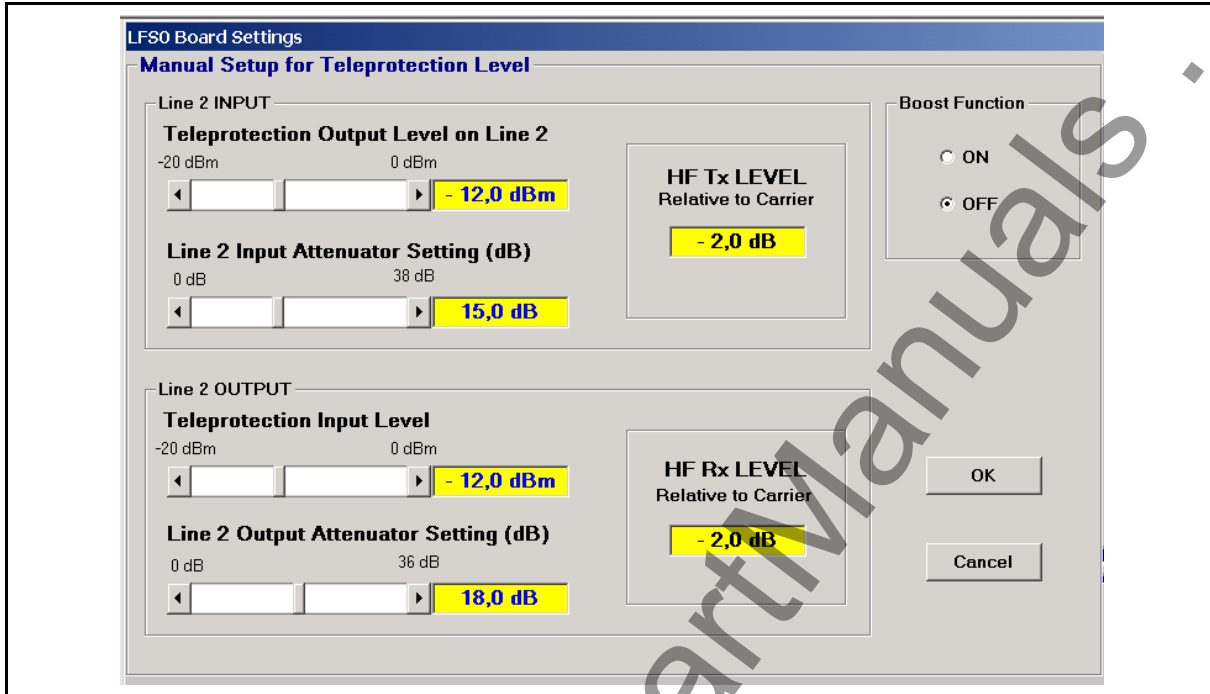

FIGURE 31 – MANUAL SETUP TELEPROTECTION (LFS)

8. LOW FREQUENCIES EQUALIZER WINDOW

PLC equipment performs the equalization of the HF received frequency band.

The equalization process is based on eight test tones to be generated at the remote PLC equipment. On the local PLC, received tones are compared and equalised.

Select EQUALIZATION command on standard menu bar and click the board field in order to enter "**Low Frequencies Equalizer**" procedure.

8.1 Menu bar

8.1.1 Equalizer

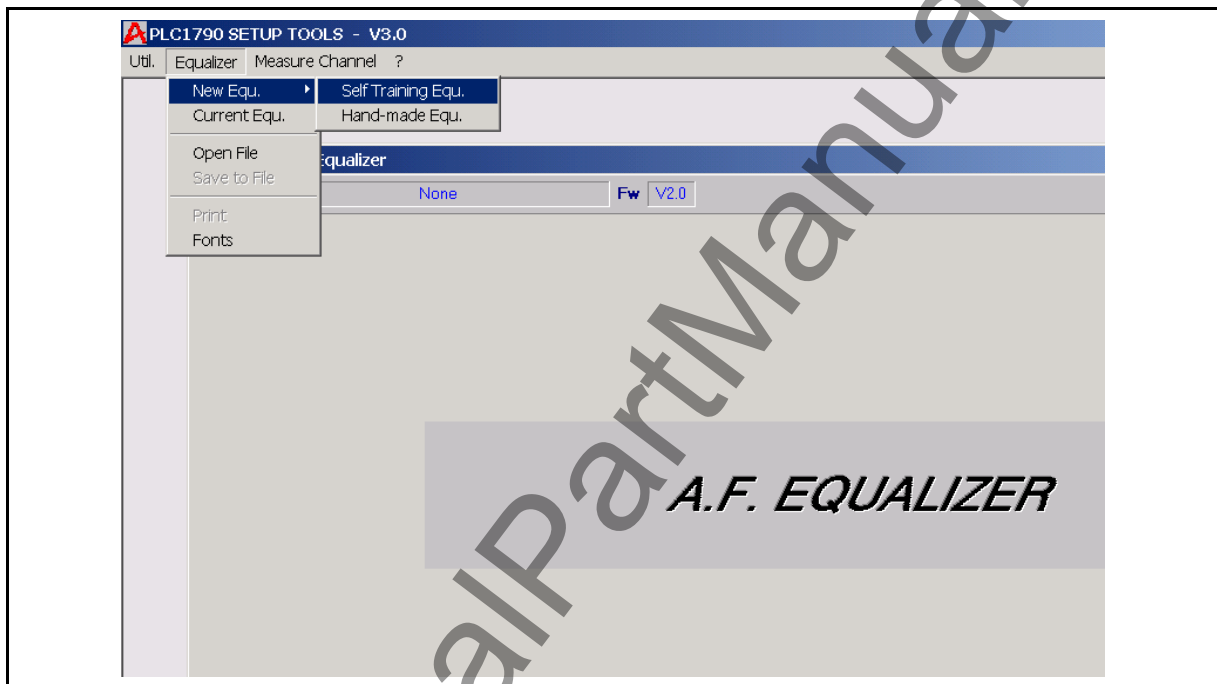

FIGURE 32 – AF EQUALIZER START WINDOW

NEW EQUALIZER

- Enabled when no on-screen equalization
- Sub-menu self training equ. (See § 8.2.1)
- Sub-menu **Hand Made Equ.** (See § 8.2.2)

CURRENT EQUALIZER

- Enabled when no on-screen equalization
- Opens the **Current Equalizer** window (See §8.2.3)

OPEN FILE

- Enabled when no on-screen equalization
- Allows to display an existing equalization file by opening the WINDOWS standard dialogue box

SAVE TO FILE

- Enabled when on-screen equalization
- Allows to save the on-screen equalization in a file by opening the WINDOWS standard dialogue box

PRINT

See § 12.1

FONTS

See § 12.2

8.1.2 Measure Channel

WITH EQUALIZER

- Always enabled
- Opens the **Measuring Channels With Equalizer** window (See § 7.2.4)

WITHOUT EQUALIZER

- Always enabled
- Opens the **Measuring Channels Without Equalizer** window (See § 7.2.4)

8.1.3 Help

See § 3.1.9

8.2 Working windows

8.2.1 Self Training Equalizer

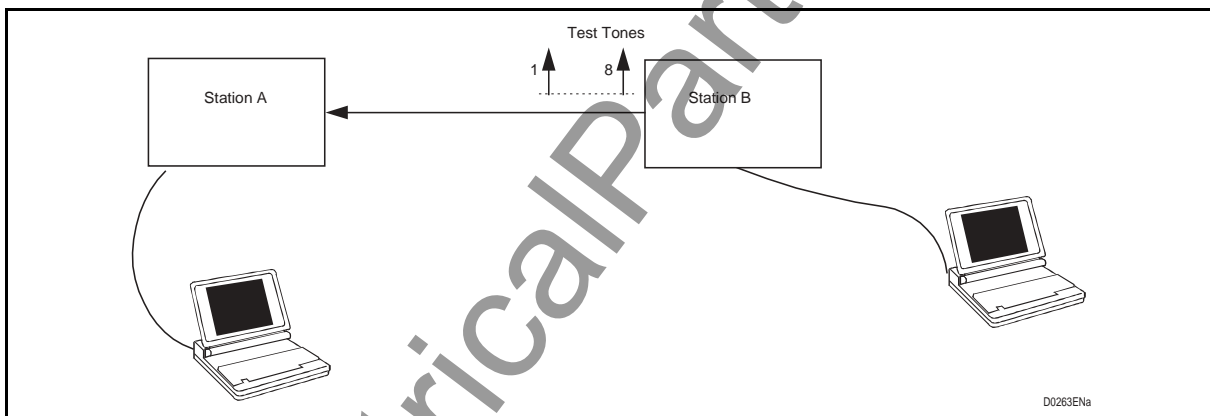

FIGURE 33 – EQUALIZATION PROCEDURE

PLC equipment can equalise the received signal using an adaptive type equalizer.

At the remote PLC, station B, after activating the current equalizer session on the UBBP (PLC 1790) or LFS board, automatically the PLC generates eight test tones to the HF interface.

On the local PLC, station A, the operator enters the equalization session and chooses **NEW EQUALIZER** and **SELF TRAINING EQUALIZATION** menu in order to equalize automatically the received frequency band transmitted by the remote station B.

This operation is achieved through the reading of 8 test tones transmitted from the remote station B

Three successive windows are displayed.

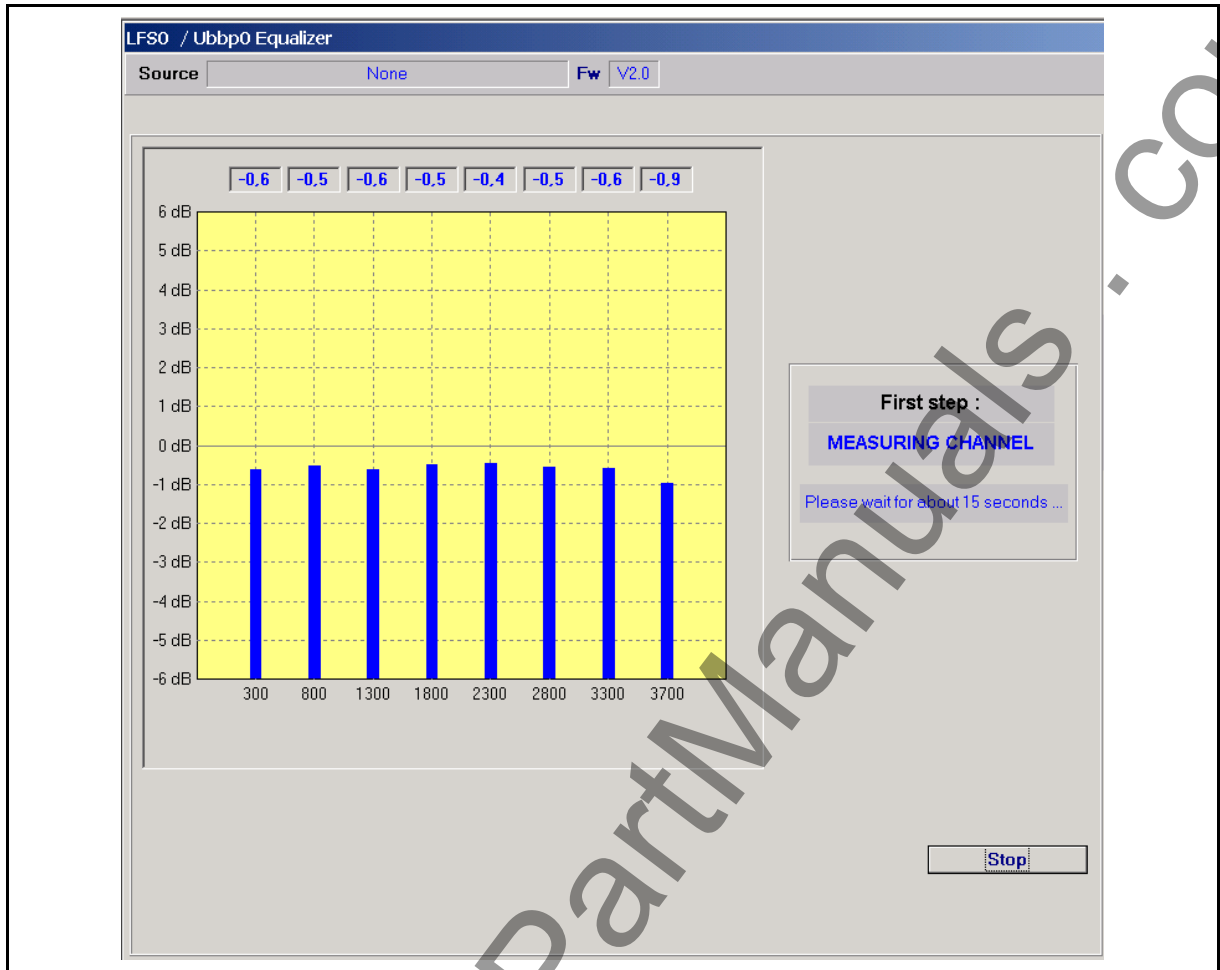

FIGURE 34 – WINDOW N°1 : MEASURING CHANNELS

The received signal are compared with the local references in order to calculate the equalization curve. The self equalization training can take few seconds as well as a few minutes. During the elaboration a graphic bar shows the equalization percentage.

NOTE: If the tone generation has not been launch on the remote PLC, there is an error message



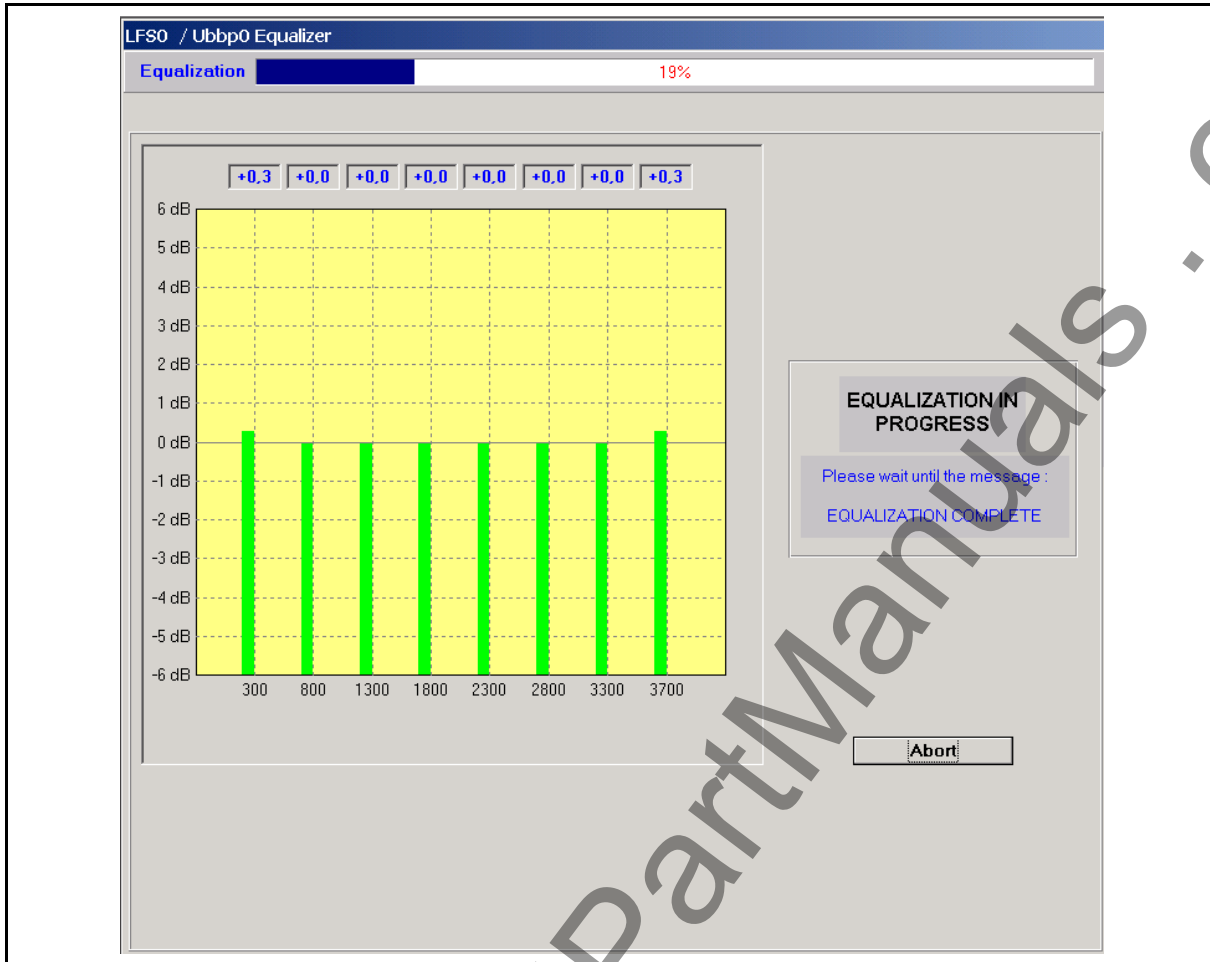

FIGURE 35 – WINDOW N°2 : ACTION IN PROGRESS

At the end of the process a message will confirm the completion of the equalization function and a window will show a bar graphic with the 8 test tones before and after the equalization function.

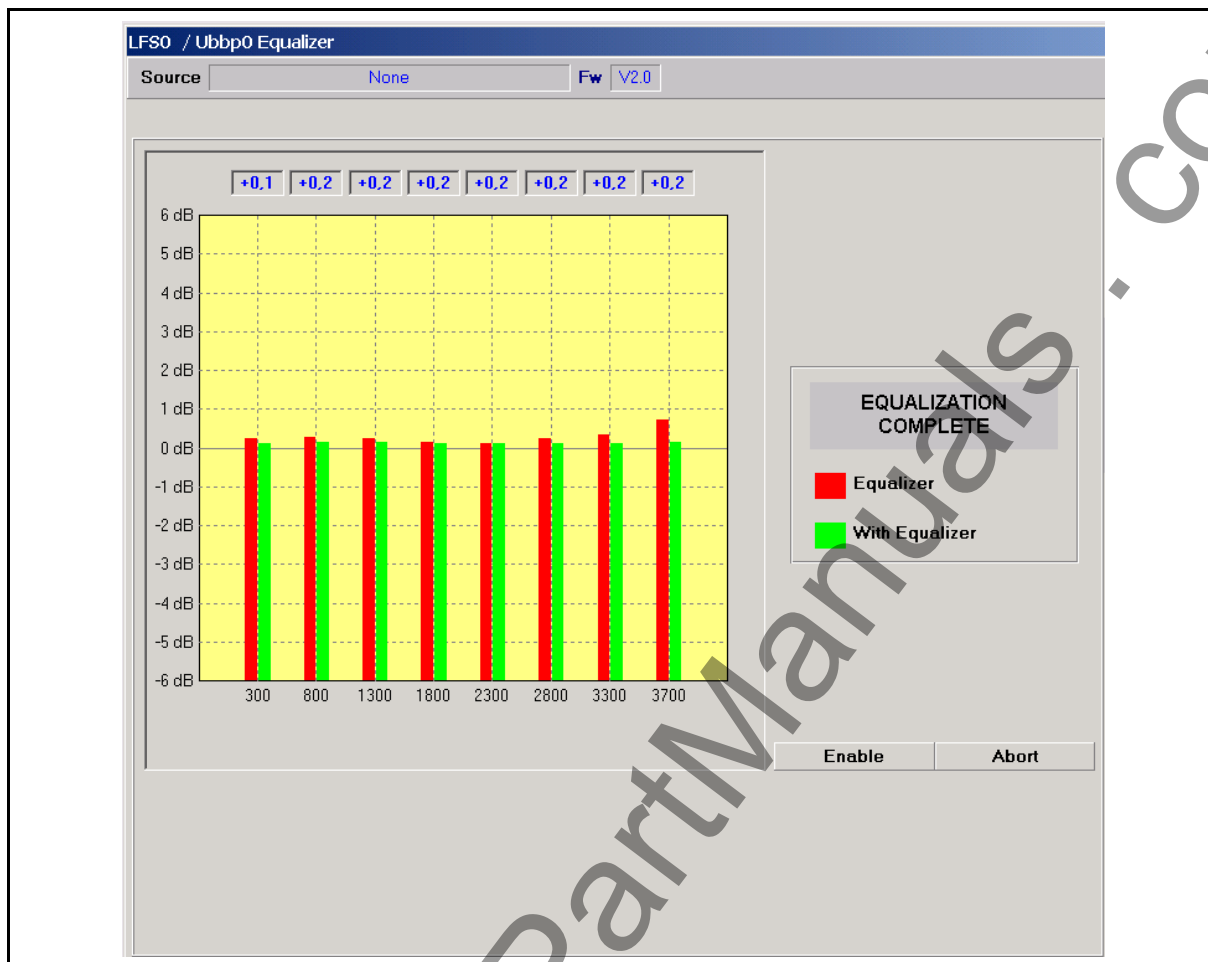

FIGURE 36 – WINDOW N°3 : ACTION COMPLETED

After this operation the equalizer curve is saved on EEPROM - LFS or UBBP card (PLC1790) - but it is not active yet.

The operator clicking on "**ENABLE**" can activate this equalization curve or clicking on "**ABORT**" can reject it.

8.2.2 Handmade Equalizer

The operator can design an "Handmade Equalization" curve choosing, for each of 8 test tones, the attenuation value in the range from -6 dB to +6 dB. This curve can be activated by clicking on "**START**" button.

The handmade equalization function lets the freedom to the operator to design any kind of equalization curve.

Three successive windows are displayed.

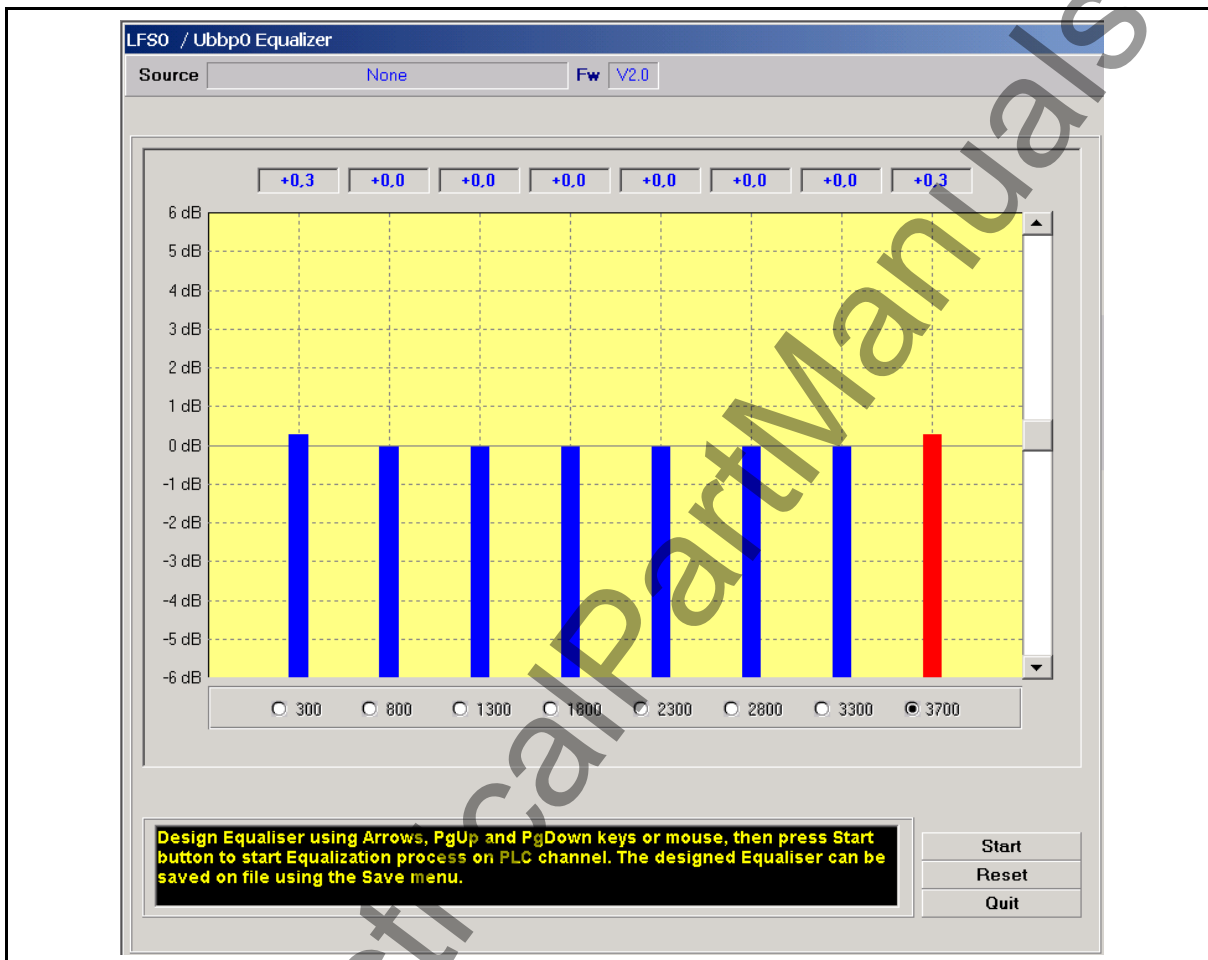

FIGURE 37 – WINDOW N°1 : EIGHT SIGNALS HAND ADJUSTMENT

completed the adjustment the sub-menus are enabled to:

- "**QUIT**" button : back to the **Low Frequencies Equalizer** window
- "**RESET**" button : resets the levels with their nominal values
- "**START**" button : runs the equalization and opens window N°2

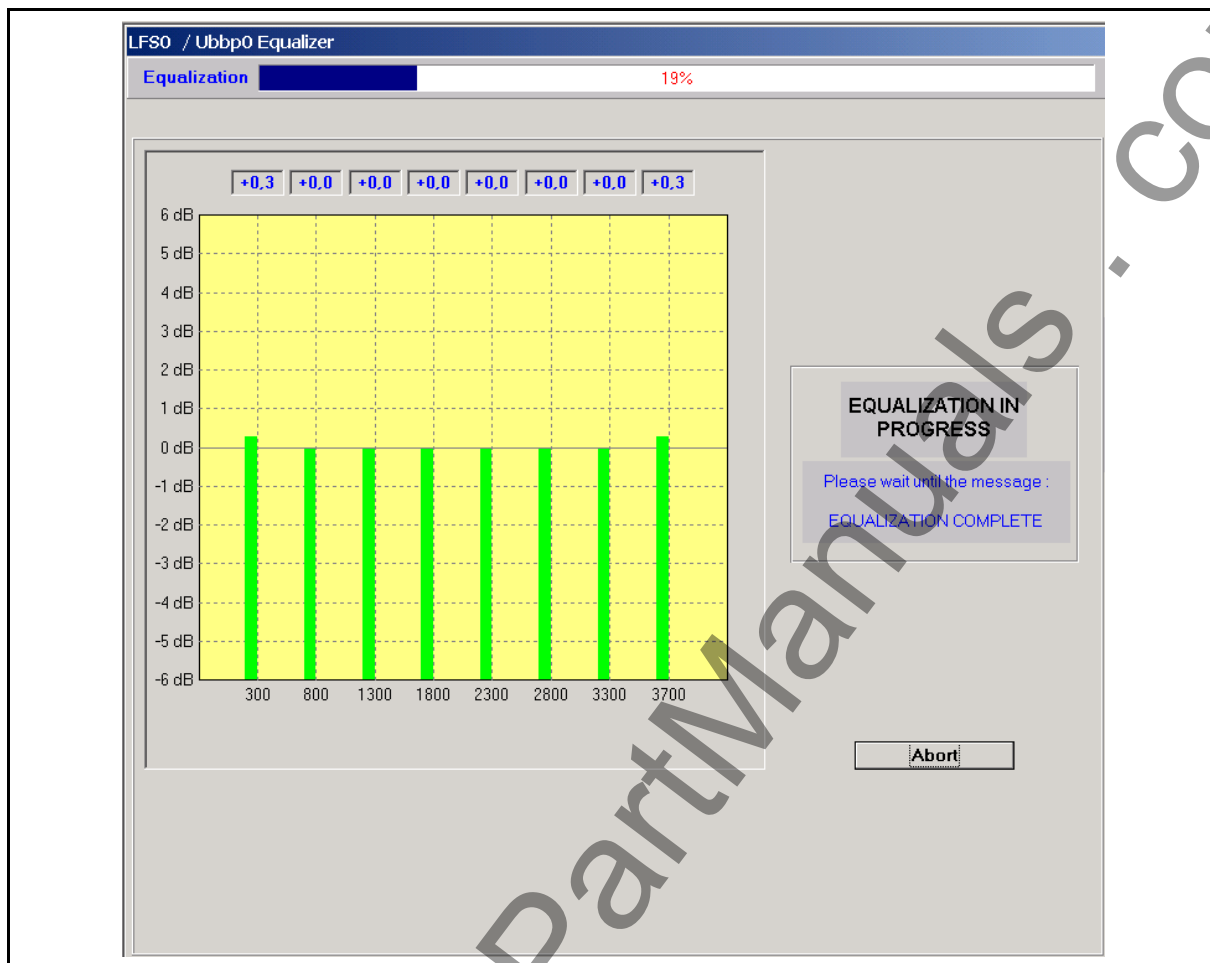

FIGURE 38 – WINDOW N°2 : HAND DESIGN EQUALIZATION IN PROGRESS

The operator can activate "ENABLE" or reject "ABORT" the equalization handmade curve.

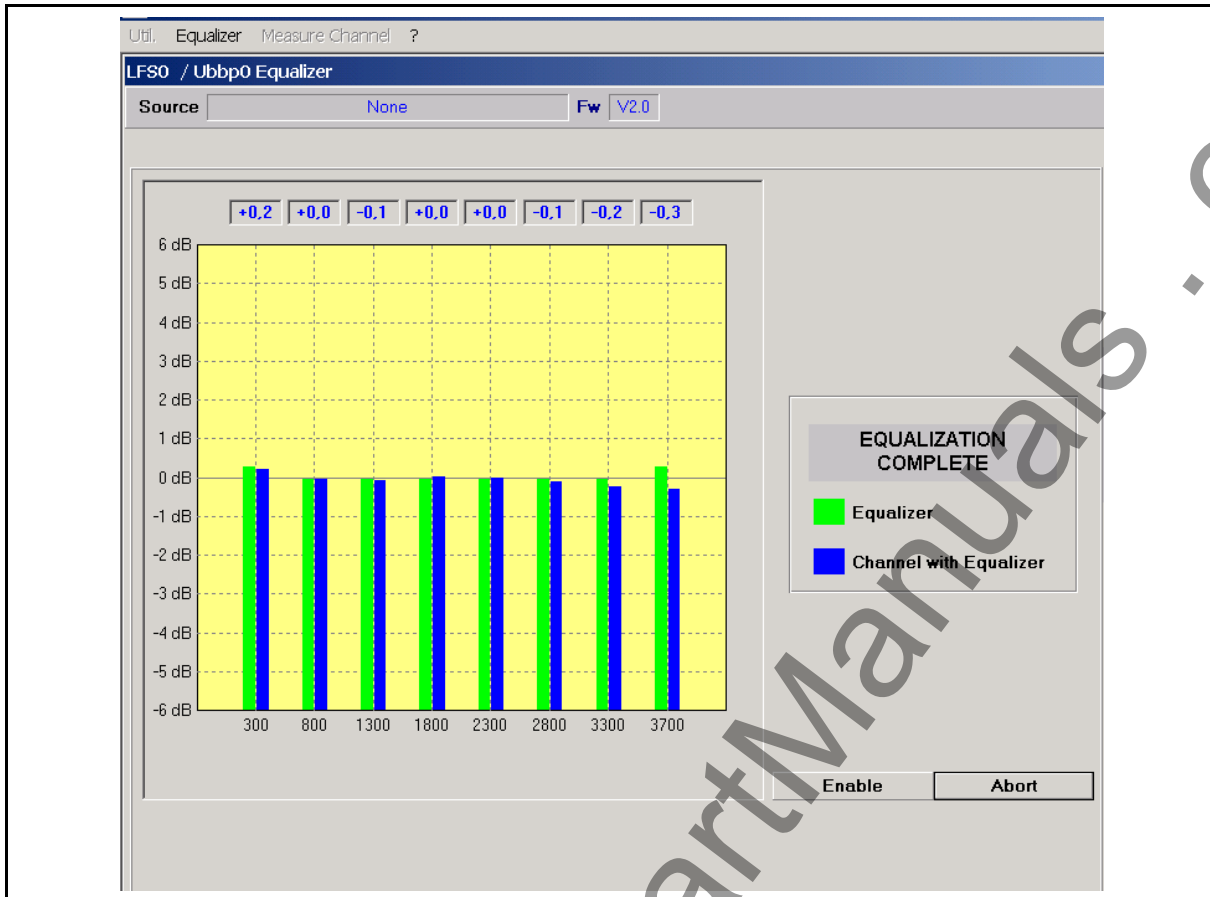

FIGURE 39 – WINDOW N°3 : HAND DESIGN EQUALIZATION ACTION COMPLETED

Completed the equalization :

- save to file
- print
- fonts

sub-menus are enabled to save and print this equalization. All the other menus and sub-menus are disabled.

8.2.3 Current Equalizer

The operator can display the current equalizer curve resident on the EEPROM selecting "**CURRENT EQU**". The equalizer can be enabled or disabled by clicking on the two available buttons. "**QUIT**" exits the menu and disable the equalizer.

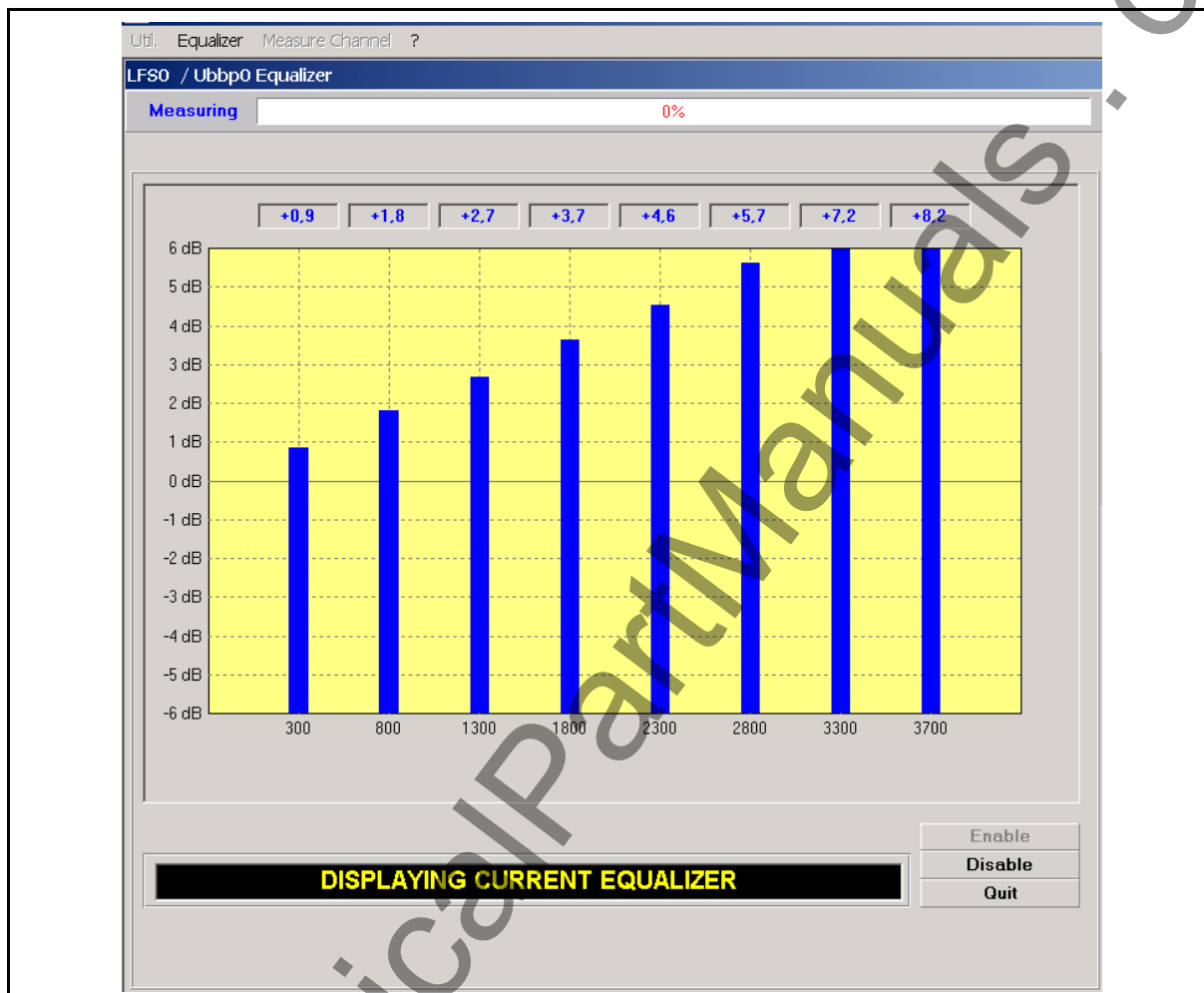

FIGURE 40 – CURRENT EQUALIZER CURVE

Following sub-menus :

- save to file
- print
- fonts

are enabled to save and print this equalization. All the other menus and sub-menus are disabled.

Buttons :

- "QUIT" : back to the Low Frequencies Equalizer window
- "DISABLE" : stops the equalization (enabled when equalization is activated)
- "ENABLE" : starts the equalization (enabled when equalization is not activated)

8.2.4 Measure Channel
WITH EQUALIZER

The operator can check the connection with the remote PLC station measuring the communication channel with or without the equalizer function in order to evaluate the quality of the transmission link from the point of view of the reception frequency band de-equalization.

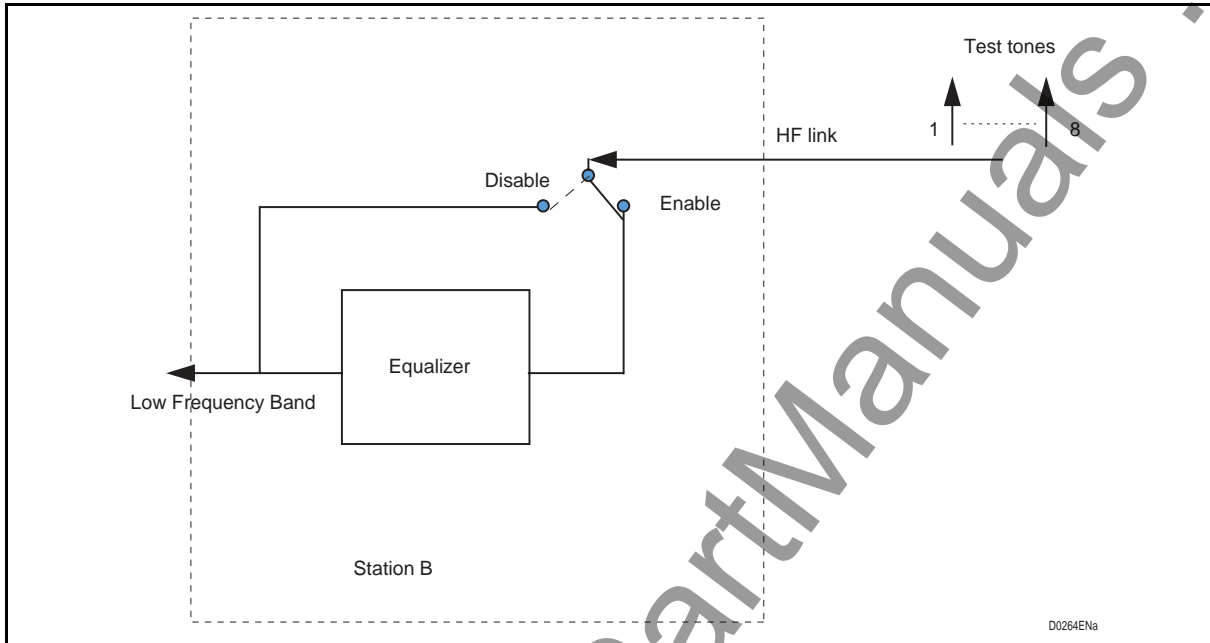

FIGURE 41 – EQUALIZER : ENABLE / DISABLE

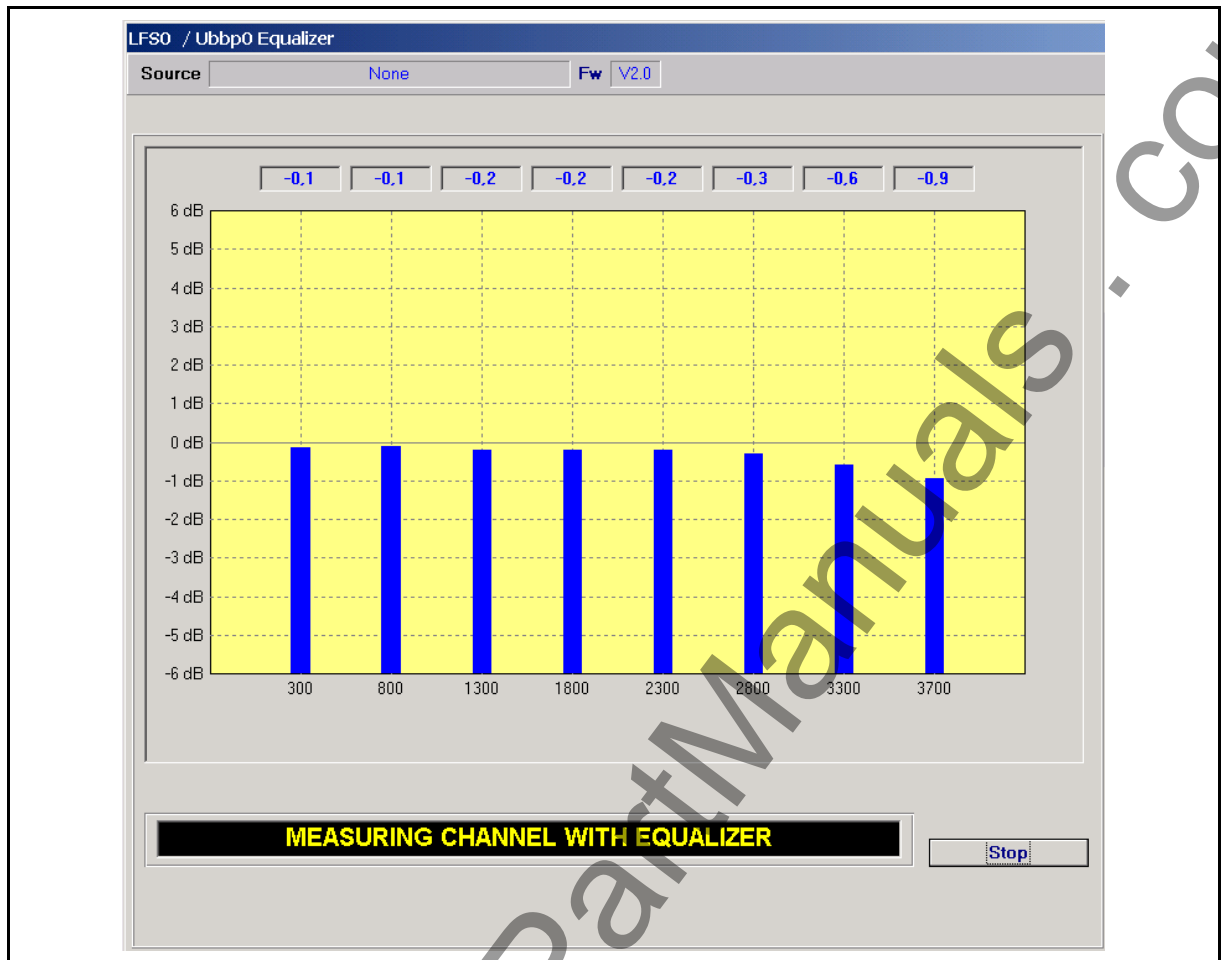

FIGURE 42 – CHANNELS MEASURE WITH EQUALIZER

WITHOUT EQUALIZER

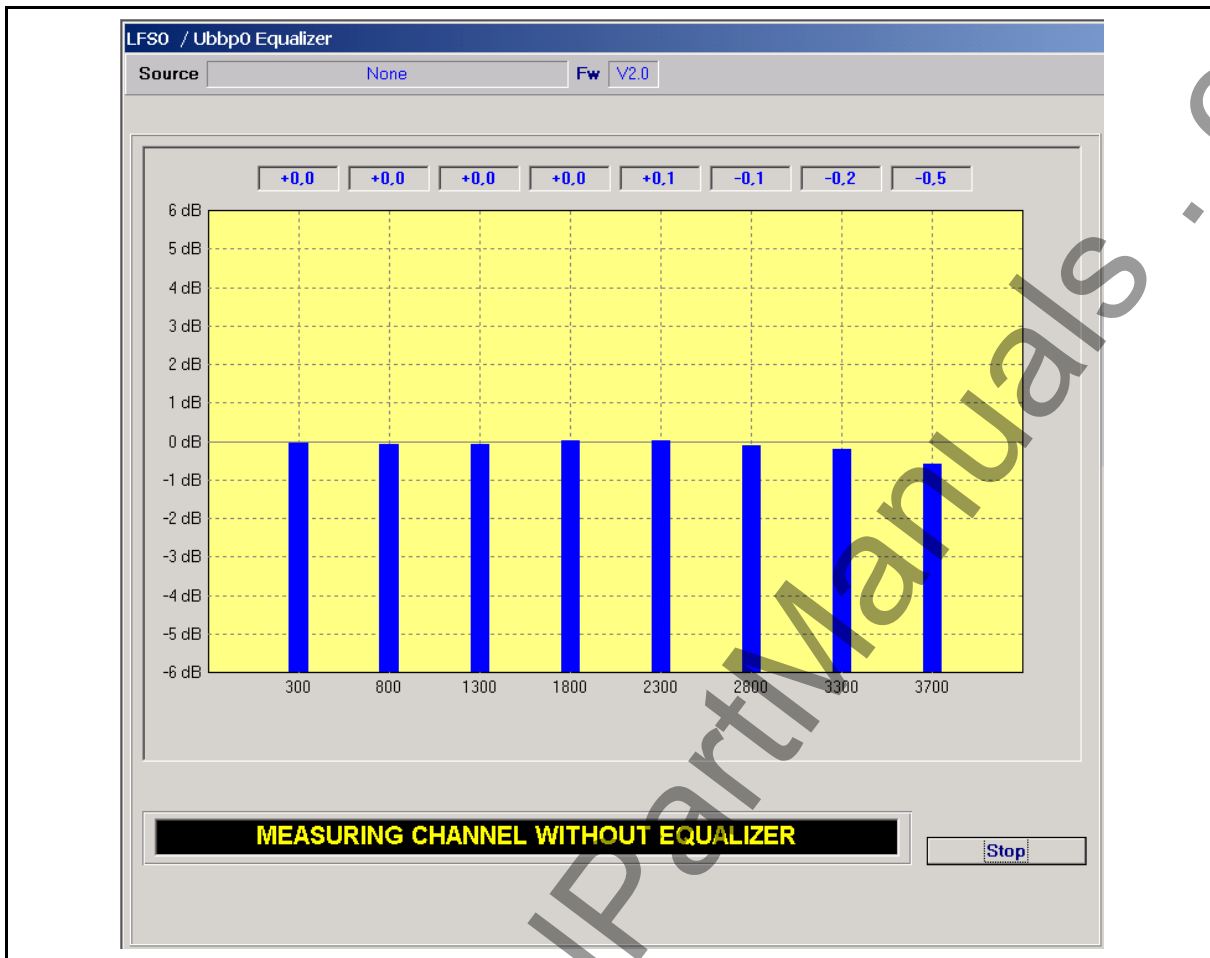

FIGURE 43 – CHANNELS MEASURE WITHOUT EQUALIZER

9. MODAF/ELNU BOARD ON LINE MEASUREMENTS

Select ELNU MEAS. ON LINE command on standard menu bar in order to enter **Elnu Board Measurements** procedure. PLC 1790/B R2 performs either on-line and off-line measurements.

The measurements are available only with the PC connected to the PLC equipment

9.1 Menu bar

9.1.1 Util

Similar to the Base window UTIL menu (§ 4.2.1), except for the EXIT sub-menu which allows only to come back to the Base window and not to quit the application.

9.1.2 Measurements

Always enabled

The operator can monitor the status of AGC operation, measure the noise level at the PLC input of the receiver path and check the alarm flags.

START

- Always enabled
- Opens the **MODAF/ELNU Board Measurements** window

STOP

- Enabled when measurements window is on screen
- Stops measurements and takes the measurements window away

9.1.3 Monitor

Always enabled :

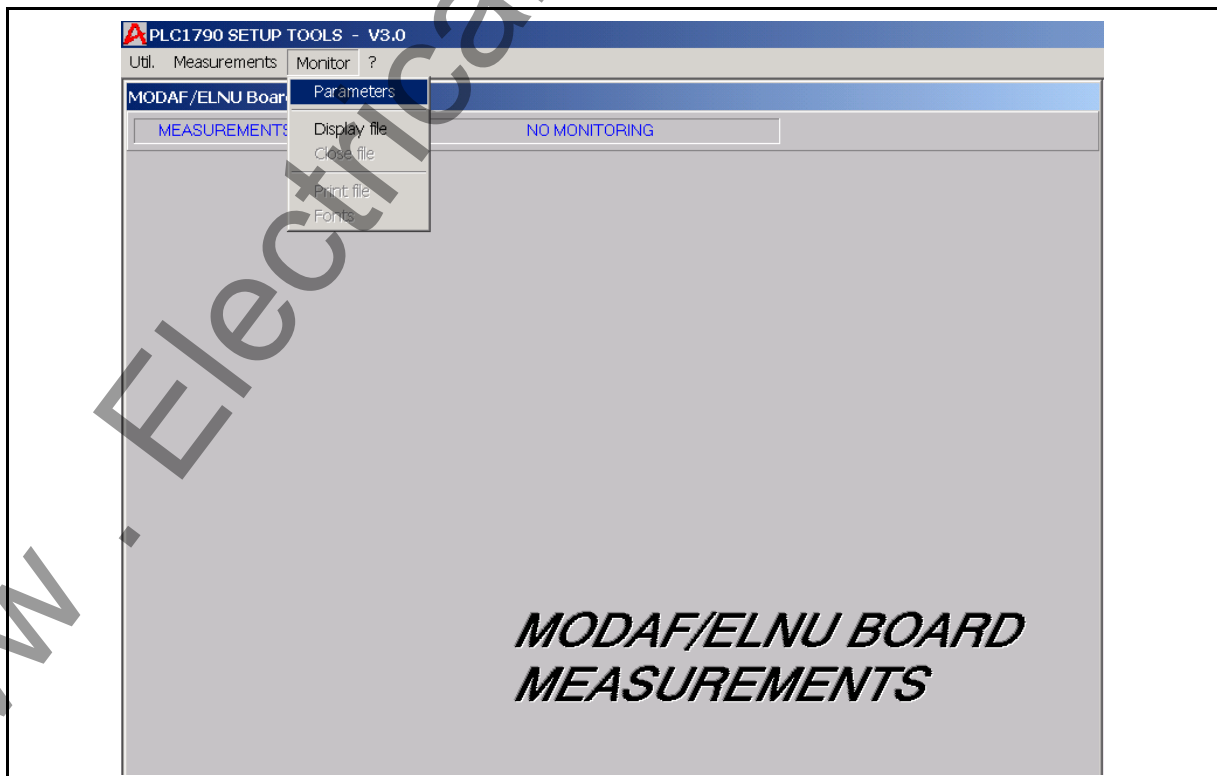

FIGURE 44 – ELNU ON LINE MEASUREMENTS WINDOW

PARAMETERS

Always enabled, displays the measurement recording criteria windows.

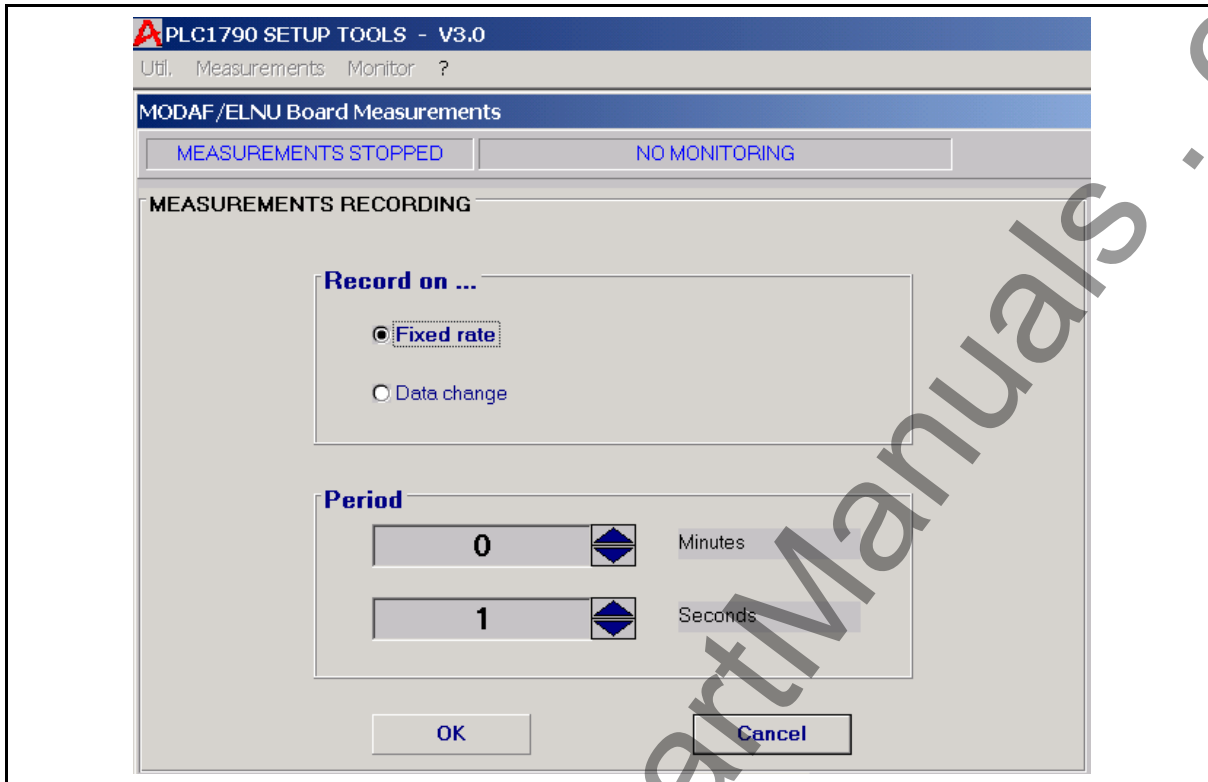

FIGURE 45 – ELNU MEASUREMENTS RECORDING

The **Period** frame is disabled for "**DATA CHANGE**" selected in "**Record on**" area.

The period can reach up to 120' and 59"

When the operator logs the data the program opens a file with extension ".Mes" with the start up parameters.

The measurement can be saved on disk file at fixed rate choosing within the allowed period or whenever the position of the AGC, noise level or alarm status change

Always enabled - Opens :

DISPLAY FILE

- Always enabled
- Opens the 'Record File [FileName]' window to choose the file where all the on line measurements will be stored

CLOSE FILE

- Enabled when no on-screen equalization
- Allows to display an existing equalization file by opening the WINDOWS standard dialogue box

PRINT FILE

- Enabled when on-screen equalization
- Prints the on-screen equalization on the system printer

9.1.4 Help

See § 3.1.9

9.2 State bar

Located under the menu bar

9.2.1 Measurements type

Always visible - Measurements states displayed :

- "Measurements in progress"
- "Measurements stopped"

9.2.2 Monitoring type

Always visible - Monitoring states displayed :

- **"Monitoring in [FileName]"** : measurements saved in [FileName]
- **"Displaying [Filename]"**
- **"No monitoring"** : measurements not saved

9.2.3 Records Number

Visible when :

- Measurements in progress (increment at each record occurrence)
- Measurements file on screen ('Records number' = number of records saved in the file)

9.3 Working windows

9.3.1 On-Line Measurements window

The PLC equipment can check several on-line measurements and alarms in order to have the equipment status overtime.

This information can be saved in a file while occurring (monitoring status).

The measurements give the status of AGC gain, Noise level and the power in the LFS board.

The alarm flags control :

- RX -5 dB The level of the receiver carrier is -5 dB or lower than the nominal level
- RX +5 dB The level of the receiver carrier is +5 dB or higher than the nominal level
- RX S/N AL. Signal to Noise ratio alarm referring to carrier level
- AGC limits AGC has reached the programmed threshold close to the AGC saturation
- PLC Limits AGC function is at saturation point
- PLL Unlocked The phase lock circuit is out of range, up to 30 Hz discrepancy
- A/D Overfl. Analogue to Digital circuit is in overflow due to the input received level
- LF Squelch Alarm which disable the received low frequency services
- Local Loop The local loop has been activated
- TX Alarm Transmission alarm has been activated
- LFS Inp. overl Overload transmission signal has been detected

Each flag is coded in a letter from A to L in order to be stored in a file.

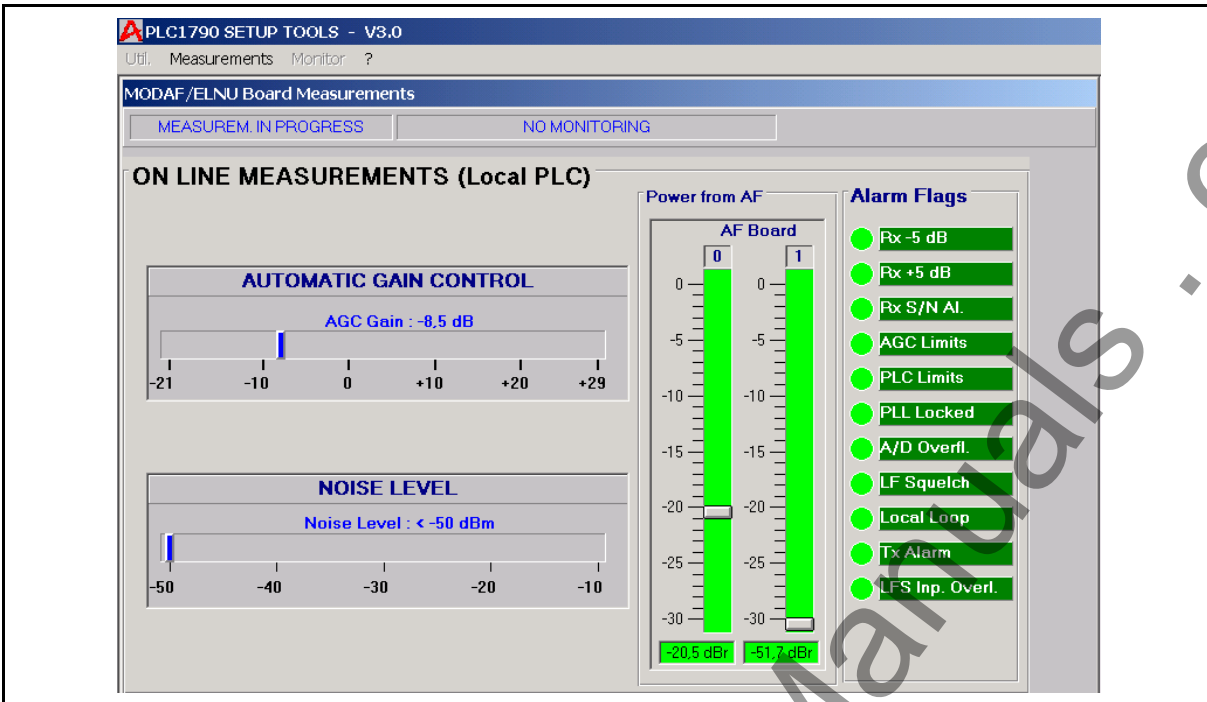

FIGURE 46 – MODAF/ELNU MEASURING ON LOCAL PLC WITHOUT RECORDING

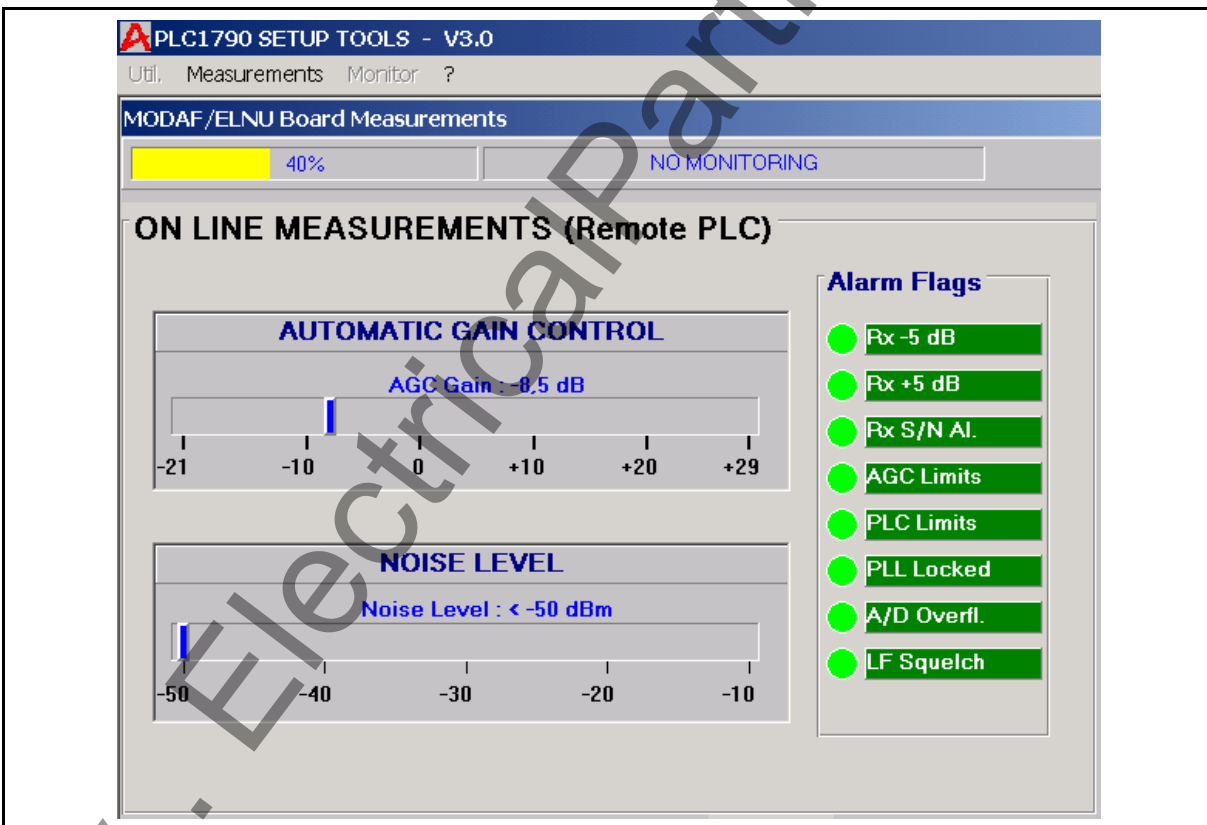

FIGURE 47 – MODAF/ELNU MEASURING ON REMOTE PLC WITHOUT RECORDING

9.3.2 Records File windows

The first window displays the state of :

- AGC level,
- Noise level,
- A - ÷ - L flags,

for each record :

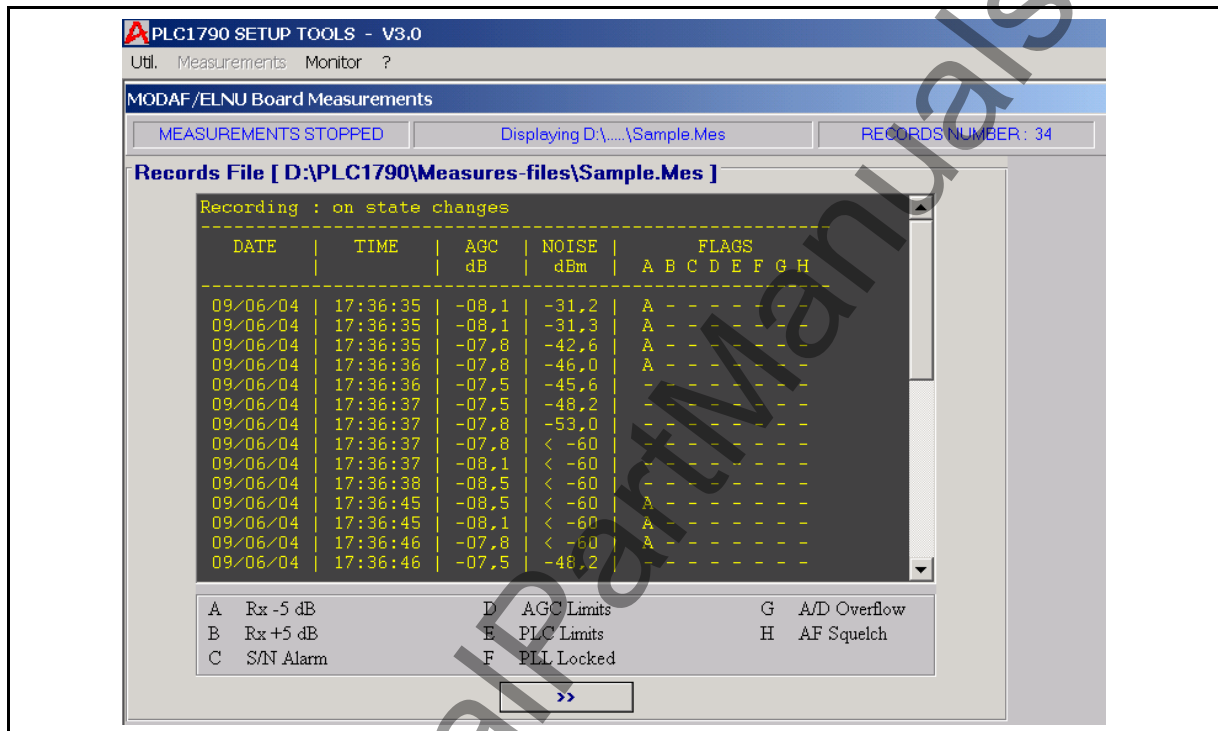

FIGURE 48 – MEASUREMENT RECORD FILE DISPLAY MAIN WINDOW

Click on ">>" to display the next window.

This window displays the state of :

- Low Frequency board 0 power level,
- Low Frequency board 1 power level,
- I - J - K flags,

for each record :

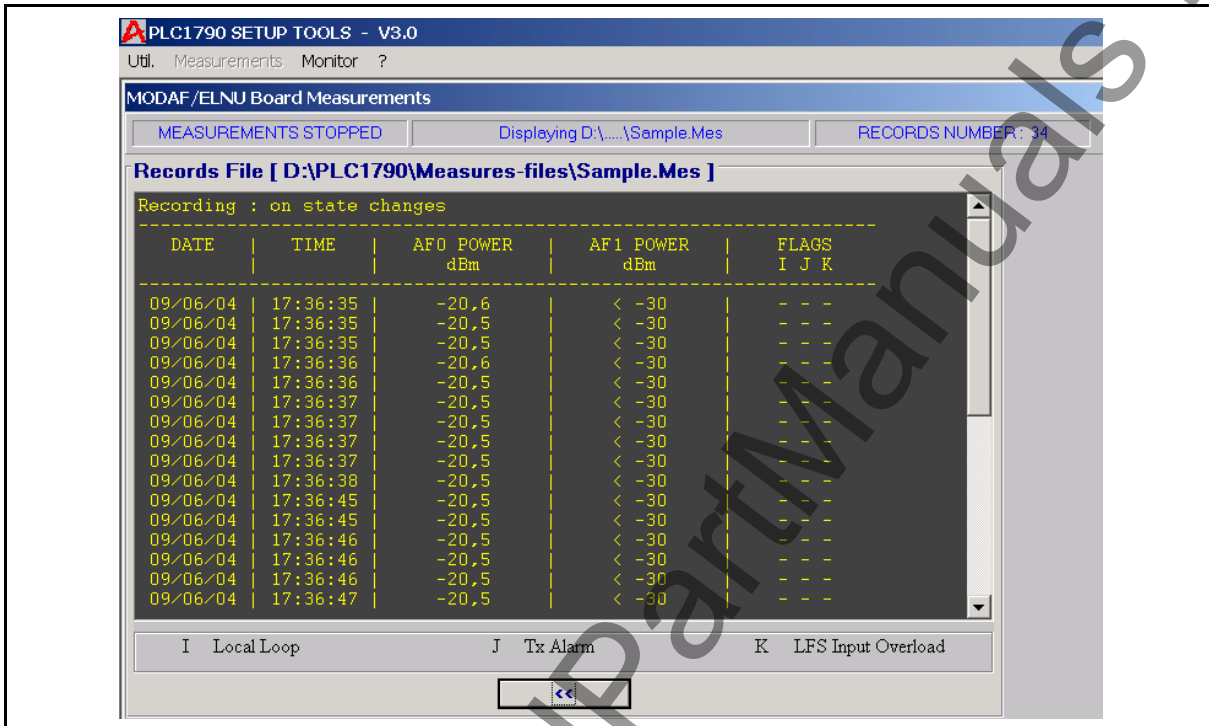

FIGURE 49 – MEASUREMENT RECORD FILE DISPLAY SECOND WINDOW

Click on "<<" to come back to the previous window.

10. AUDIO FREQUENCIES TESTS

10.1 Menu Bar

10.1.1 UTIL

Enabled for no working window opened

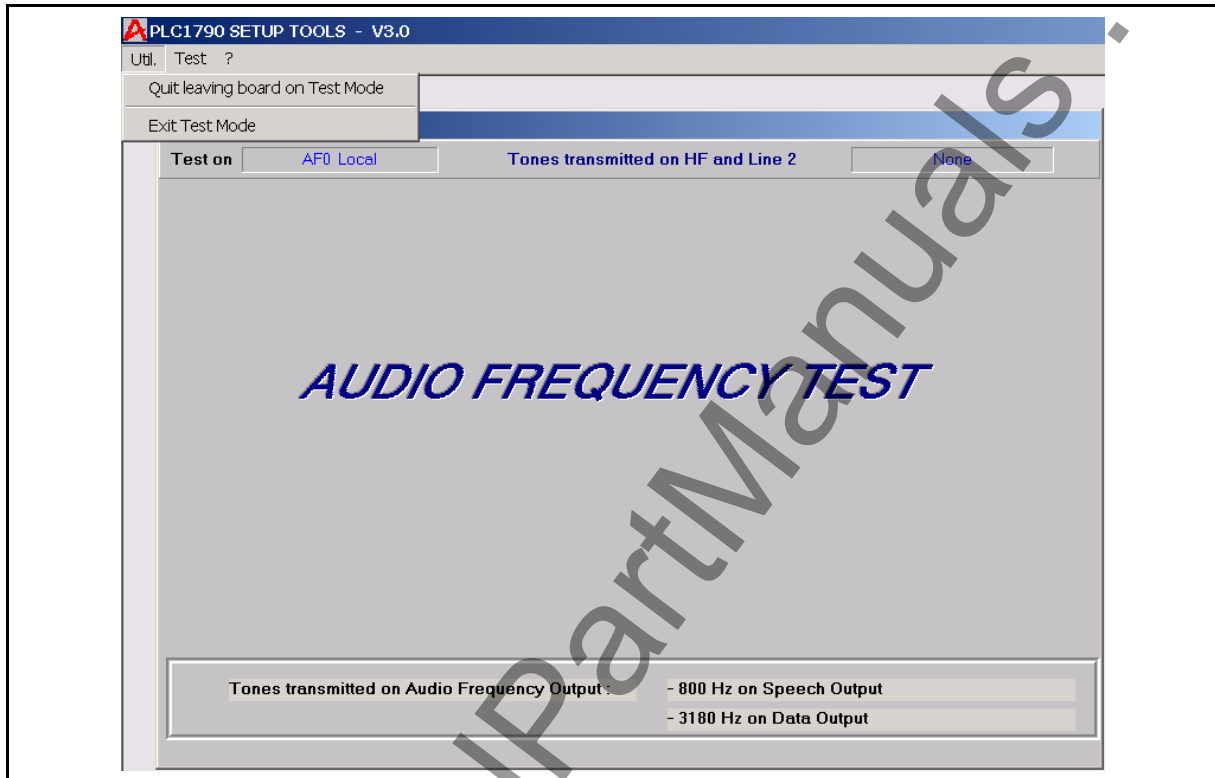

FIGURE 50 – LF TEST UTIL MENU

QUIT LEAVING AF BOARD IN TEST MODE

- Always enabled
- Keep the AF board in Test mode and off-line

EXIT TEST MODE

- Always enabled
- End the Test Mode
- Sets the AF board back on-line

10.1.2 Test

Enabled for no working window opened

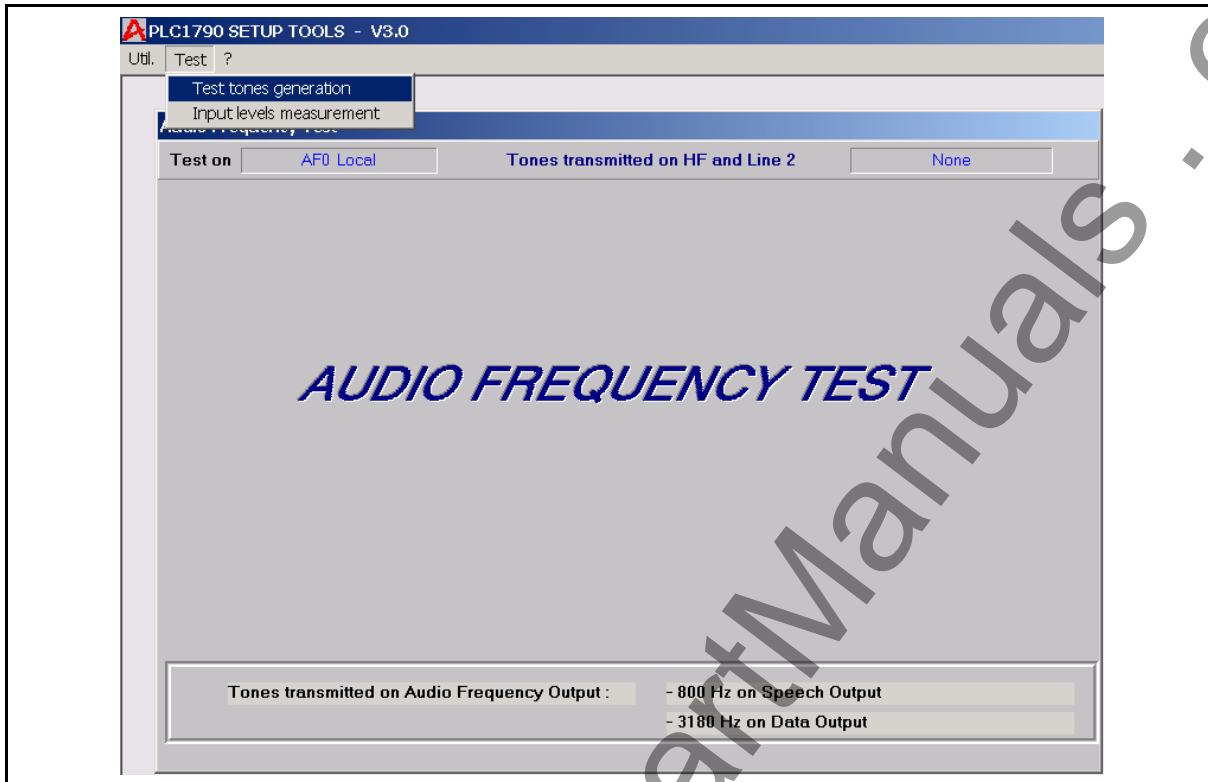

FIGURE 51 – LF TEST STARTING

TEST TONES GENERATION

- Always enabled
- Opens the **Tones Generation On HF and L2** window (See § 9.3.1)

INPUT LEVELS MEASUREMENTS

- Always enabled
- Opens the **Input Measurement** window (See § 10.3.2)

10.1.3 Help

See § 3.1.9

10.2 State bar

Located under the menu bar

10.2.1 Test on

Always visible - Identifies the LF board onto the test is running on.

10.2.2 Tones transmitted on HF and L2

Always visible - Displays the tone(s) selected by the operator in the **Tones Generation on HF and L2** window (§ 10.3.1)

10.3 Working windows

10.3.1 Tones Generation On HF and L2

The PLC equipment generate:

- a 800 Hz test tone in order to check the LFS speech receiver path
- a 3180 Hz tone in order to check the LFS telegraph receiver path
- up to 8 tones can be programmed in order to check the HF or L2 transmission paths.

Measurement must be carried out whit a selective voltmeter.

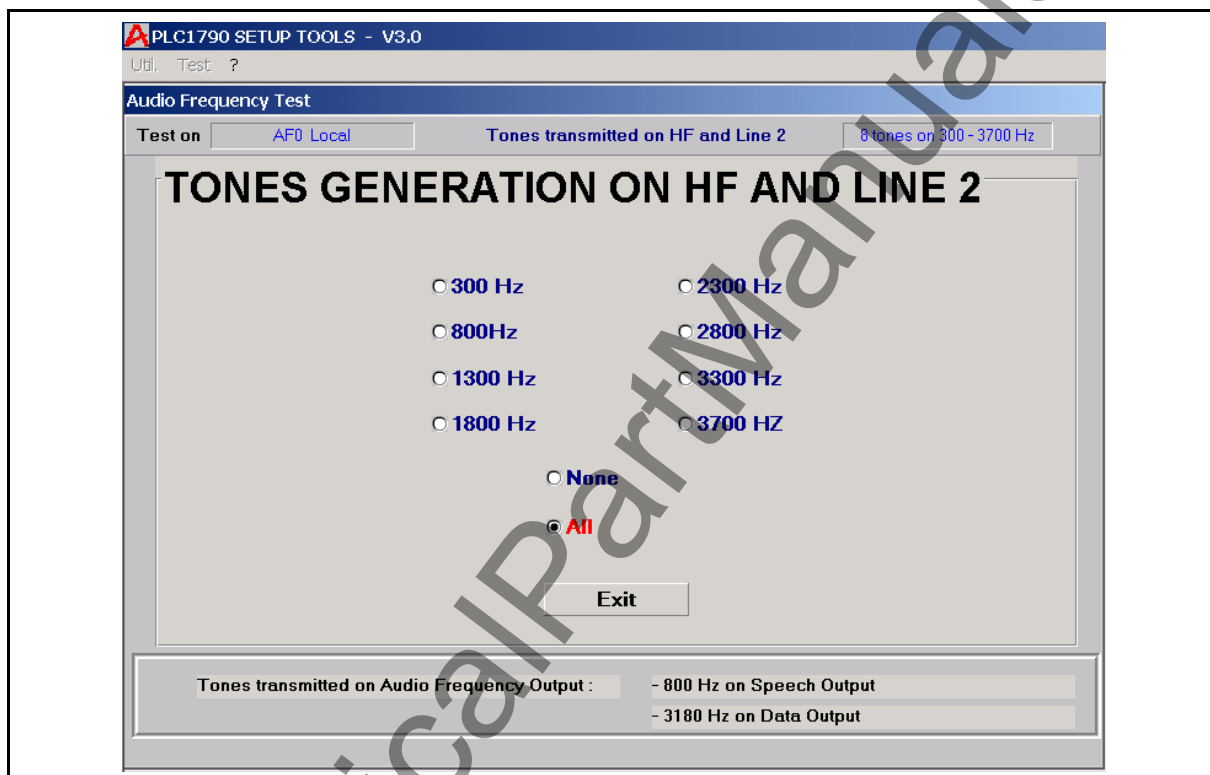

FIGURE 52 – LF TEST TONES GENERATION

10.3.2 Input Measurement

Using external generators, LFS input paths can be checked, by local programming terminal, referring to LINE 2 input, Speech input and telegraph channel input.

The transmitted level by the remote PLC terminal (nominal 4W speech level, -3,5 dBm) can be checked using the local programming terminal which detects the level in the LFS board coming from HF section.

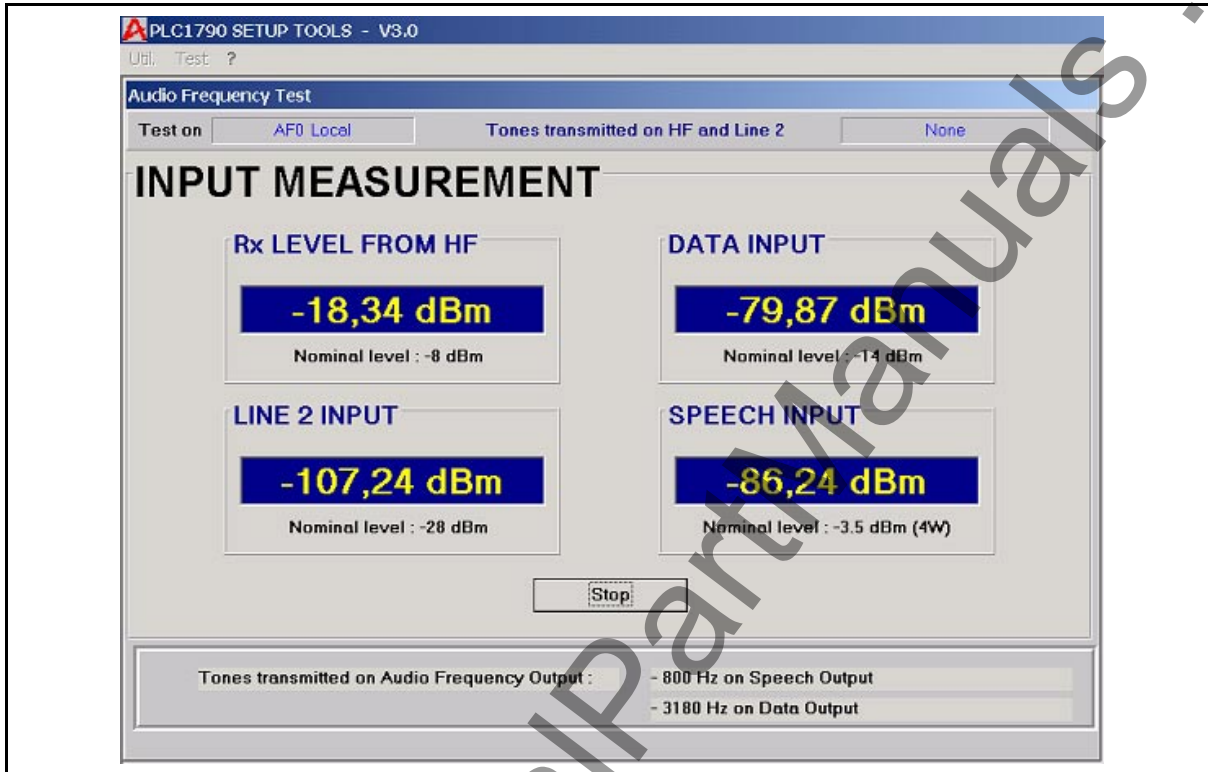

FIGURE 53 – LF INPUT SIGNAL MEASUREMENT WINDOW

11. LOOP TEST

11.1 Local

The operator can activate a local loop function to send back, via the reception path, the transmitted signal in order to verify the both transmission and reception paths.

The PLC equipment, if the speech service is programmed in 2 wires interface, must be terminated on 600 Ohm impedance in order to avoid unpredictable dangerous drawbacks.

11.1.1 PLC local loop enable

Before to enable the local loop, a warning message is displayed by the MMI.

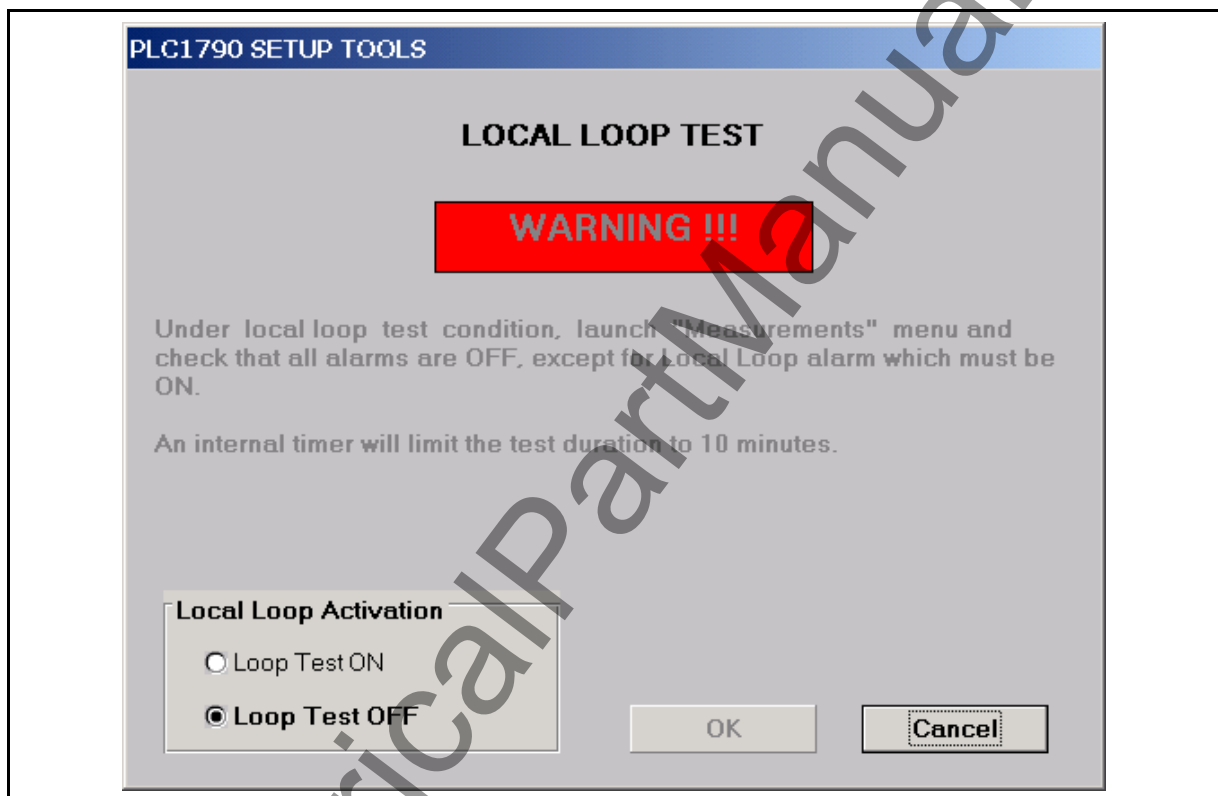

FIGURE 54 – LOCAL LOOP WARNING

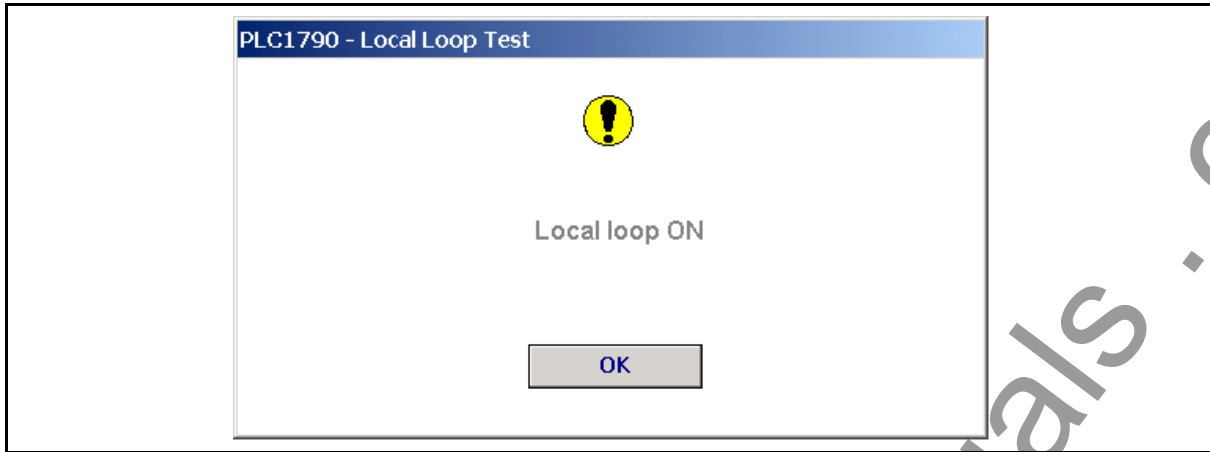

FIGURE 55 – LOCAL LOOP ENABLED

The lower state bar is updated after click on OK in the message box

The operator can verify the result of local loop function checking the alarm status using the MEASUREMENT menu.

In this case the Local Loop flag will be activated.

11.1.2 Local loop disable

The lower state bar is updated after click on OK in the message box

11.2 Remote loop test

The operator can enable the remote loop test function in order to check the connection with the remote station without any operator in the far-end PLC 1790 equipment.

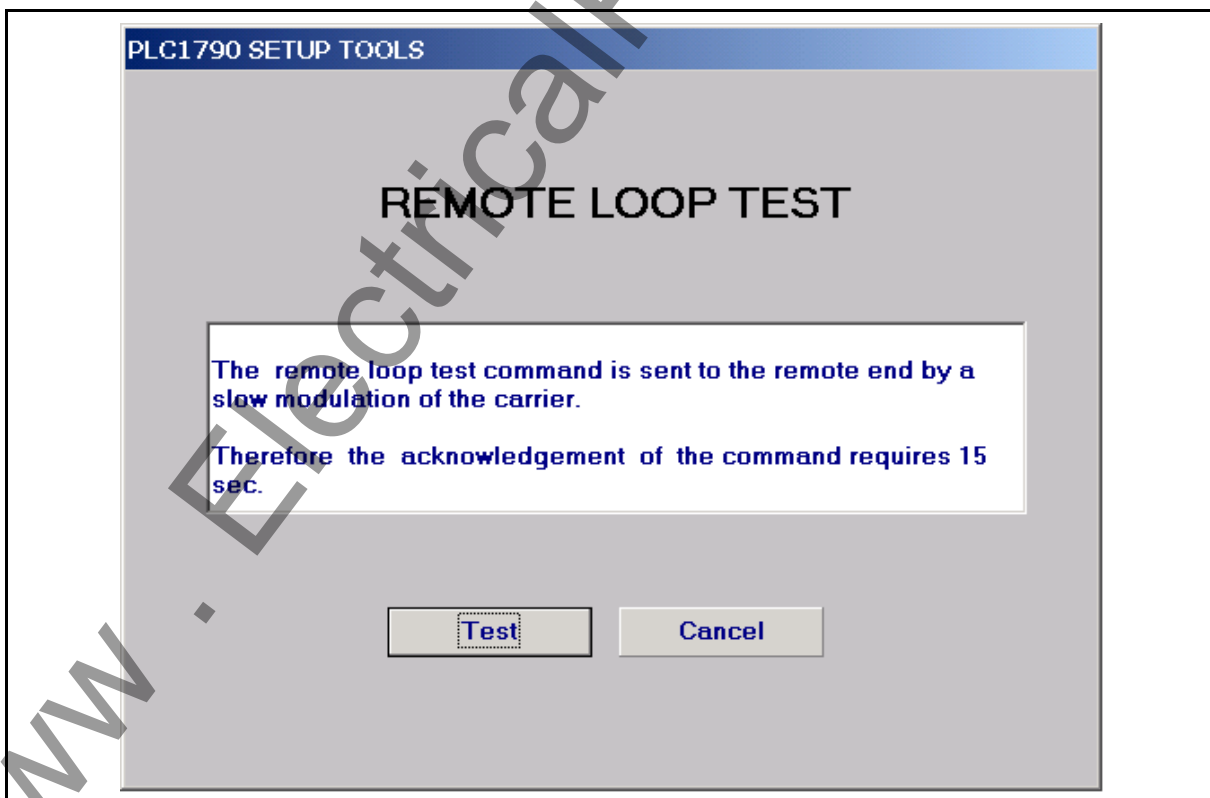

FIGURE 56 – REMOTE LOOP WARNING

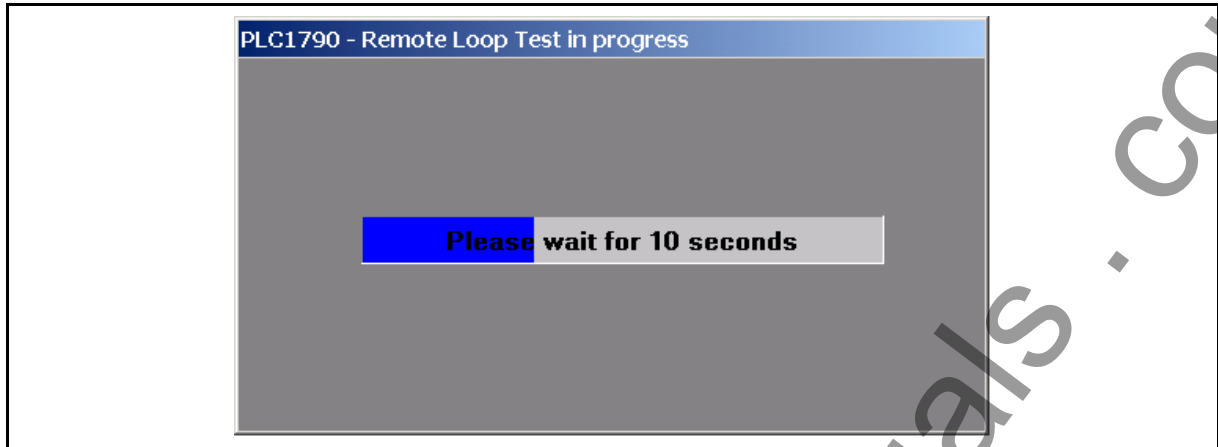

FIGURE 57 – REMOTE LOOP TEST IN PROGRESS

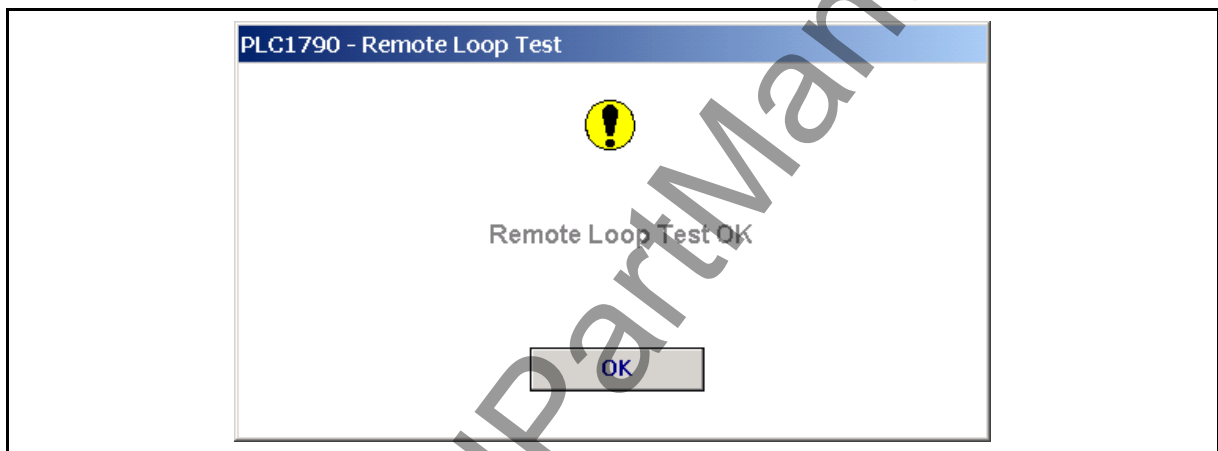

FIGURE 58 – END OF REMOTE LOOP TEST

www . ElectricalPartManuals . com

12. PRINT FEATURES

The following functions are printable :

- **Setup** : ELNU board, UBBP board (PLC1790), LFS board
- **Equalization** : UBBP board (PLC1790), LFS board
- **Measurements** : ELNU board

12.1 Print SUB-MENU

- Enabled when data are displayed on screen
- On-screen data are printed by the printer selected in the WINDOWS Control Panel

12.2 Fonts SUB-MENU

- Always enabled
- Allows to change the system printer fonts name and size. A modification in one functional window (**Setup, Equalization, Measurements**) is applied to all the windows of the MMI.

12.3 QUIT THE MMI

The only way to quit the MMI is from the Base window :

- Click on the UTIL/EXIT sub-menu or,
- Click on **Close** menu item of the Controlbox.

13. PASSWORD MANAGER

The Password Manager, supplied with MMI, allows creation, modification, read and removal of passwords. It is started with the "**Password**" icon in the **PLC1790** set of programs.

To ensure confidentiality of passwords when created, and to prevent unauthorised access, this utility is itself protected by a password.

On start-up the following menus appear on screen :

- Password
- Help

13.1 Password Menu

The PASSWORD menu allows the access password to the Password Manager to be read or modified. The factory setting for this password is **PLC1790** (uppercase); it is advisable to change it before doing anything else :

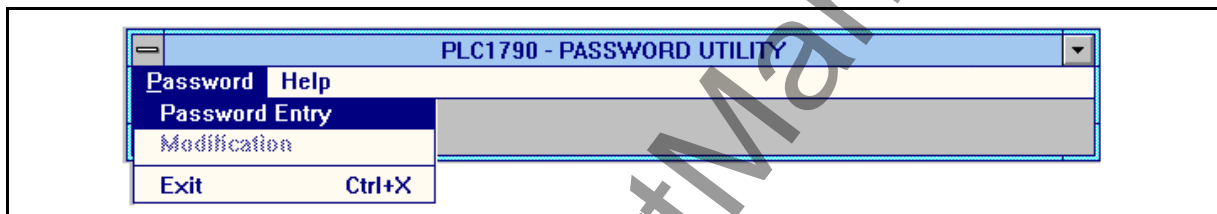

FIGURE 59 – PASSWORD MENU

Open the **Main Password Capture** window :

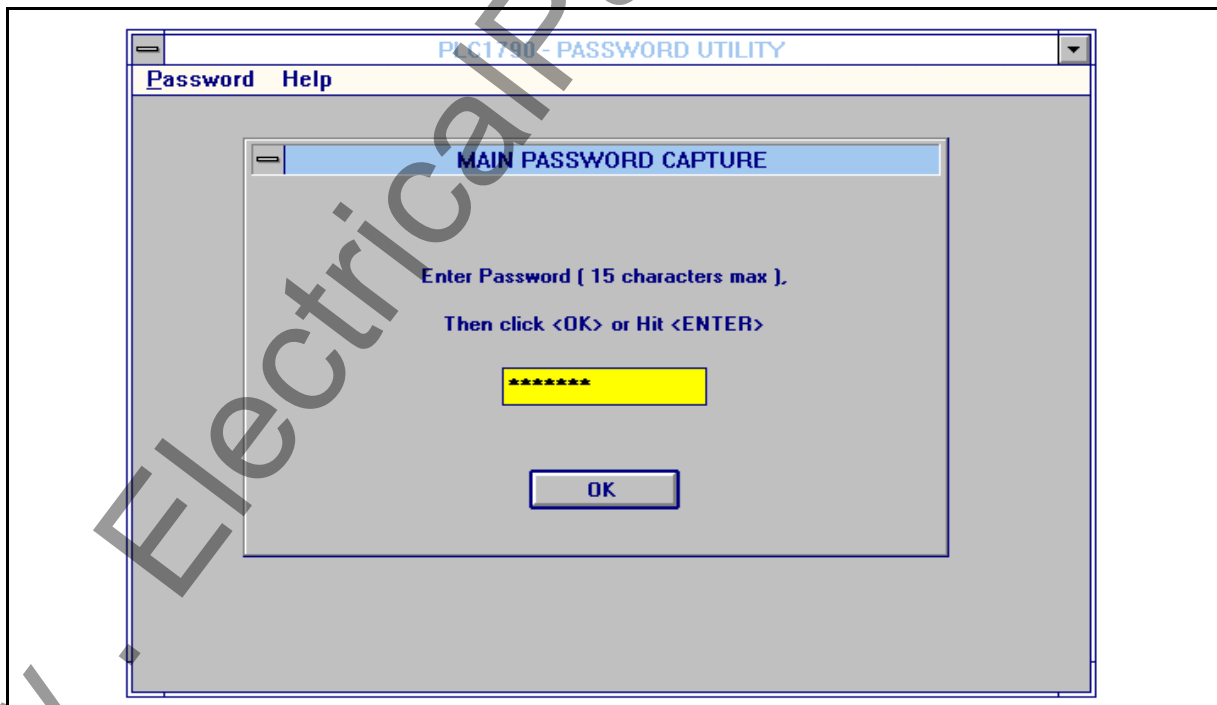

FIGURE 60 – PASSWORD SETUP

1. Enter **PLC1790** in uppercase in this window
2. Close the window with OK or <Enter> => enables MENU/MODIFICATION menu
3. Click on MENU/MODIFICATION => Opens the **Password Change** window
4. Enter new password in this window

Characteristics of access password : 1 to 15 characters selected only from the following.

- Uppercase letters (A to Z)
 - Lower case letters (a to z)
 - figures (0 to 9)
 - ! " # \$ % & ' () * + , - . / : ; < = > ? @ [\] ^ _ ` { | } ~
5. Close the modification window with OK or <Enter> => opens the confirmation window
 6. Enter the new password again as requested : password is case-sensitive (Upper or lower case).

Close the confirmation window with OK or <Enter> => displays confirmation message. CREATE PASSWORDS, LIST PASSWORDS, HELP menus, and PASSWORD/MODIFICATION sub-menu are enabled when this window is closed.

WARNING : RECORD YOUR NEW PASSWORD CAREFULLY, SINCE THE SOFTWARE WILL HAVE TO BE COMPLETELY REINSTALLED IF YOU FORGET THE PASSWORD.

13.2 Create Passwords Menu

CREATE PASSWORDS menu is displayed after the access password is recognised. It opens the **Passwords Entry** window :

The password is case-sensitive (Upper or lower case).

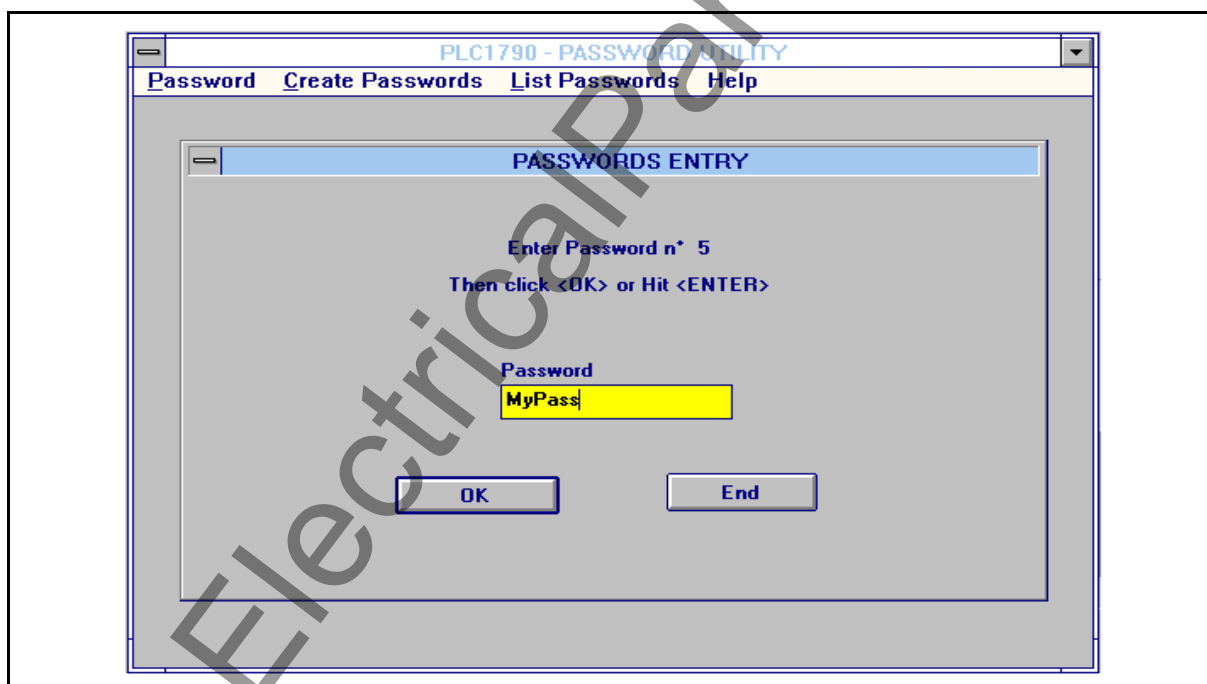

FIGURE 61 – PASSWORD DEFINITION

User passwords have the same characteristics as the access password (see § 13.1).

13.3 List Passwords Menu

This menu is displayed with the CREATE PASSWORDS menu after the access password has been recognised. It shows the list of existing passwords for consultation and/or removal.

A password may be deleted by selecting the line concerned, clicking on DELETE, and answering YES to the subsequent request to confirm the deletion.

13.4 Quitting password manager

To quit Password Manager and return to WINDOWS, click on PASSWORD/EXIT sub-menu.

www.ElectricalPartManuals.com

www.ElectricalPartManuals.com

Publication: 1790B/EN T/F11

