

## CBS 212/CBS 212A CURRENT BOOST SYSTEM

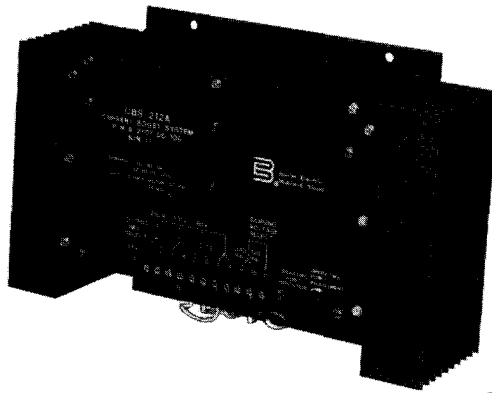
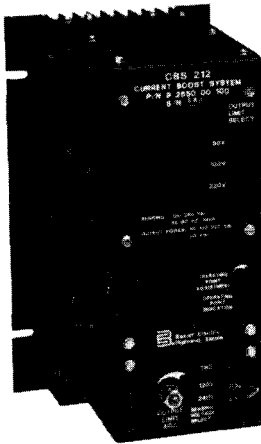

### APPLICATION:

The CBS 212 and CBS 212A Current Boost Systems are solid-state excitation support devices designed to supply 20 Amps for 10 seconds to the field. These units, combined with their respective current transformers and SSR voltage regulator, provide excitation support to the generator field during generator short circuit conditions and overloads, such as motor starting. Two styles are available; the CBS 212 features a reduced footprint and the CBS 212A has a low profile. The varying package design allows for meeting specific customer requirements.

### DEVICE FEATURES:

- Instantaneous response to short circuits.
- Up to 20 A field boost power for 10 seconds.
- Activated when generator voltage drops too low to maintain field current.
- For 50 or 60 Hertz brushless generators.
- Covers a wide range of generator applications.
- Adjustable forcing voltage limit.
- Available from stock.

### APPLICATION AND FEATURES

this page

### DESCRIPTION AND SPECIFICATIONS

page 2

### ORDERING

page 3

### EXTERNAL CONNECTIONS Terminals and Interconnections

page 4

### OUTLINE DRAWINGS Current Transformers and CBS Modules

pages 5 thru 8

### INSTRUCTION MANUAL

Reference Publication Number  
9 2650 00 990 (CBS 212)  
9 2707 00 990 (CBS 212A)

**B** Basler Electric

P.O. BOX 269 HIGHLAND, ILLINOIS 62249, U.S.A. PHONE 618-654-2341 FAX 618-654-2351

SQA-2  
11-93

## DESCRIPTION:

Each version of the Current Boost System consists of a current boost module and two separately supplied current transformers. These systems provide supplemental excitation, which allows the field to receive full forcing during generator overload and short circuit conditions.

The Current Boost Systems allow three wire and four wire generators to provide sustaining current during single phase and multiple phase line-to-line faults. The CBS also permits four wire generators to support phase A and B line-to-neutral faults. Phase C line-to-neutral faults also have fault sustaining capabilities when regulator input power is taken from the unshorted phases A and B.

The CBS 212 and CBS 212A sense generator output voltage. When the voltage drops below the operation point selected on the OPERATION POINT adjustment (due to a short circuit or motor start) the current boost module will extinguish the OPERATION POINT indicator and will remove the SCR "short" from the CT. The module then provides current boost to the generator exciter until the voltage returns to a level just above the operation point, and illuminates the OPERATION POINT indicator.

## SPECIFICATIONS:

• Limit Adjust .....	50% to 100% of selected output; (50/100/220 Vdc for CBS 212, 60/120/220 Vdc for CBS 212A)
• Operation Point Adjustment .....	70 to 131 Vac for 120 Volt nominal, 140 to 262 Vac for 240 Volt nominal
• Dropout Ratio .....	Dropout @ 5v above pickup point for 120 Volt nominal, dropout @ 10v above pickup point for 240 Volt nominal
• Power Dissipation .....	Less than 50 watts at continuous rating
• Storage Temperature Range .....	-85°F (-65°C) to +185°F (+85°C)
• Operating Temperature Range .....	-40°F (-40°C) to +140°F (+60°C)
• Shock .....	Withstand up to 15 G's in each of three mutually perpendicular planes
• Vibration .....	Withstand 5 to 26 Hz @ 1.2 G's; 27 to 52 Hz @ 0.036" double amplitude; 53 to 260 Hz @ 5.0 G's
• Weight	
Current Boost Module (CBS 212) .....	12.5 lbs. (5.68 Kg)
(CBS 212A) .....	15 lbs. (6.8 Kg)
BE 25925 001 .....	84 lbs. (38.2 Kg)
BE 25926 001 .....	78 lbs. (35.5 Kg)
BE 25927 001 .....	66 lbs. (30.0 Kg)
BE 25928 001 .....	122 lbs. (55.5 Kg)
BE 25929 001 .....	73 lbs. (33.2 Kg)
BE 25930 001 .....	50 lbs. (22.7 Kg)
• CT Secondary Turn Ratio	
BE 25925 001 .....	1:8
BE 25926 001 .....	1:17
BE 25927 001 .....	1:34
BE 25928 001 .....	1:69
BE 25929 001 .....	1:138
BE 25930 001 .....	1:277

## SAMPLE SPECIFICATION:

A current boost system shall be provided with the Basler Electric SSR model of voltage regulator. This unit shall sustain exciter field current during severe generator output overloads or short circuit. The current boost system shall sense generator line voltage and, upon a drop in voltage, become enabled.

The current boost system shall receive power by two CTs, installed in the phases of the generator output.

The current boost system shall be Basler Electric Company model CBS 212 or CBS 212A, with current transformers selected based on Basler recommendation and generator performance data.

## HOW TO ORDER:

### Current Transformer

For current transformer selection, select the current transformer from the table below that matches the amount of system 3 phase short circuit line current.

### Excitation Module

For reduced footprint requirements, order CBS 212; see Figure 2. For low profile requirements, order CBS 212A; see Figure 3. This unit gives mounting dimensions similar to the SSR voltage regulator.

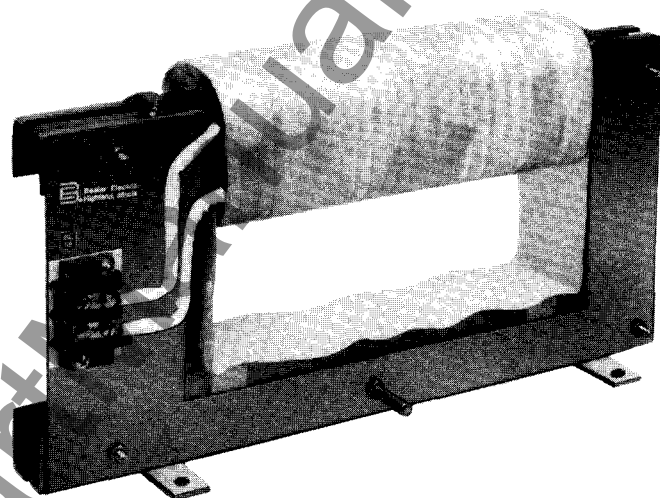

*Two current transformers are required for use with each CBS unit. Pictured above: BE 25930-001.*

There are six standard CT designs available for the current boost modules. Select the CTs from the table below.

For 3 $\phi$ Short Circuit Line Current:	Use Two (2) CTs:	Turns Ratio:
125-250 Aac	BE 25925 001	1:8
250-500 Aac	BE 25926 001	1:17
500-1000 Aac	BE 25927 001	1:34
1000-2000 Aac	BE 25928 001	1:69
2000-4000 Aac	BE 25929 001	1:138
4000-8000 Aac	BE 25930 001	1:277

**TABLE 1.**

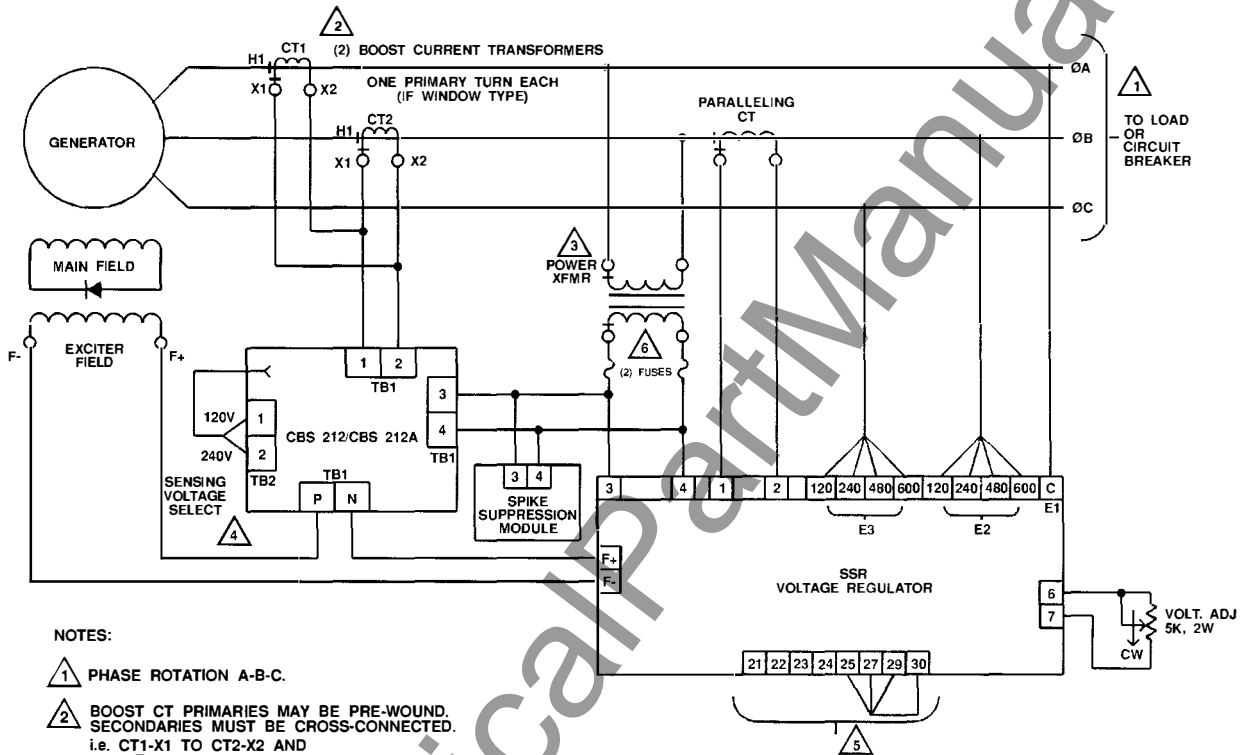

**NOTES:**

- 1 PHASE ROTATION A-B-C.
- 2 BOOST CT PRIMARIES MAY BE PRE-WOUND. SECONDARIES MUST BE CROSS-CONNECTED. i.e. CT1-X1 TO CT2-X2 AND CT1-X2 TO CT2-X1.
- 3 POWER XFMR TO BE SELECTED ACCORDING TO SSR INSTRUCTION MANUAL.
- 4 CONNECT SENSING VOLTAGE SELECT TO MATCH VOLTAGE AT CBS TERMINALS 3 AND 4.
- 5 REFER TO SSR INSTRUCTION MANUAL FOR JUMPER REQUIREMENTS.
- 6 REFER TO SSR INSTRUCTION MANUAL FOR FUSE SELECTION.

**FIGURE 1. TYPICAL INTERCONNECTION DIAGRAM.**

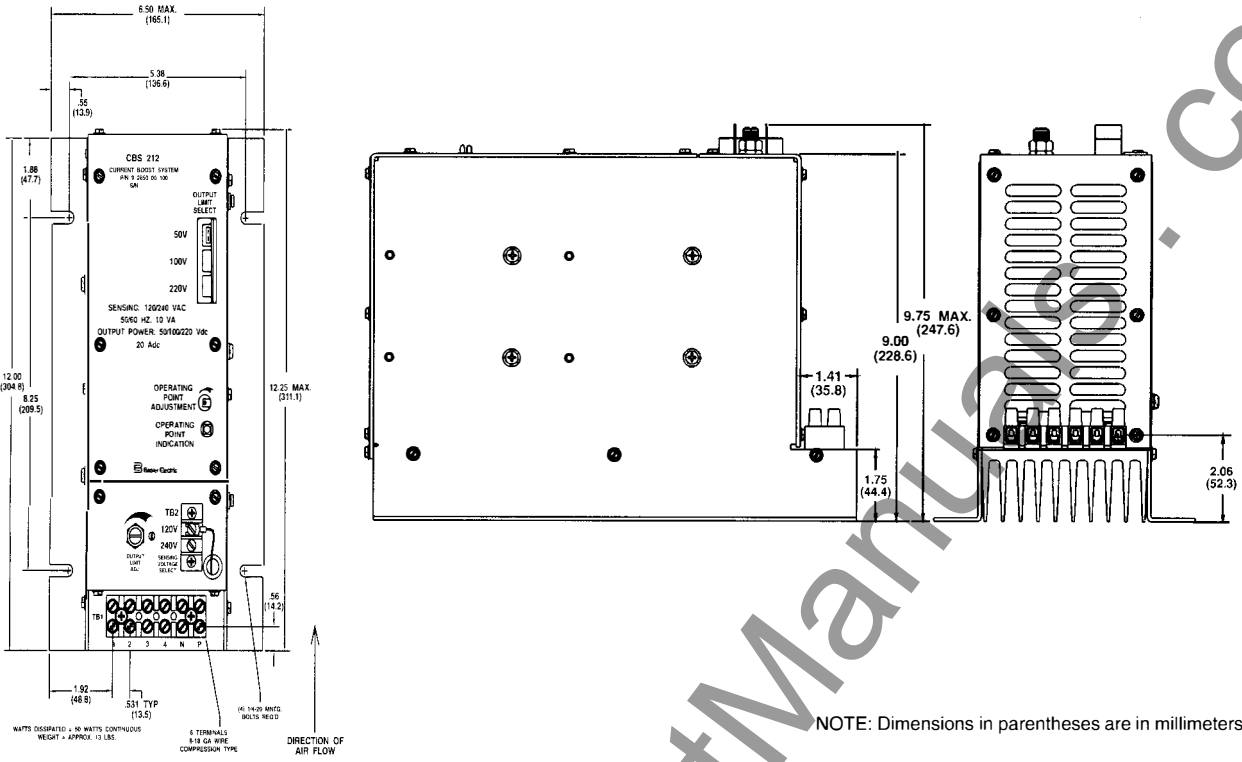
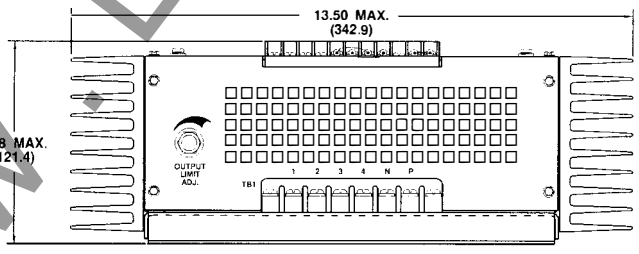
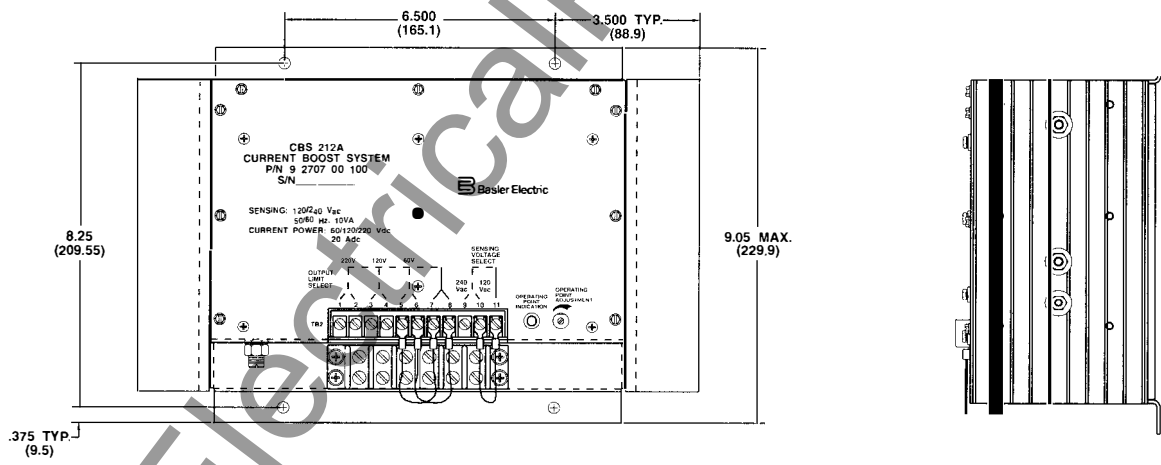

FIGURE 2. OUTLINE DRAWING.



NOTE: Dimensions in parentheses are in millimeters.

FIGURE 3. OUTLINE DRAWING.

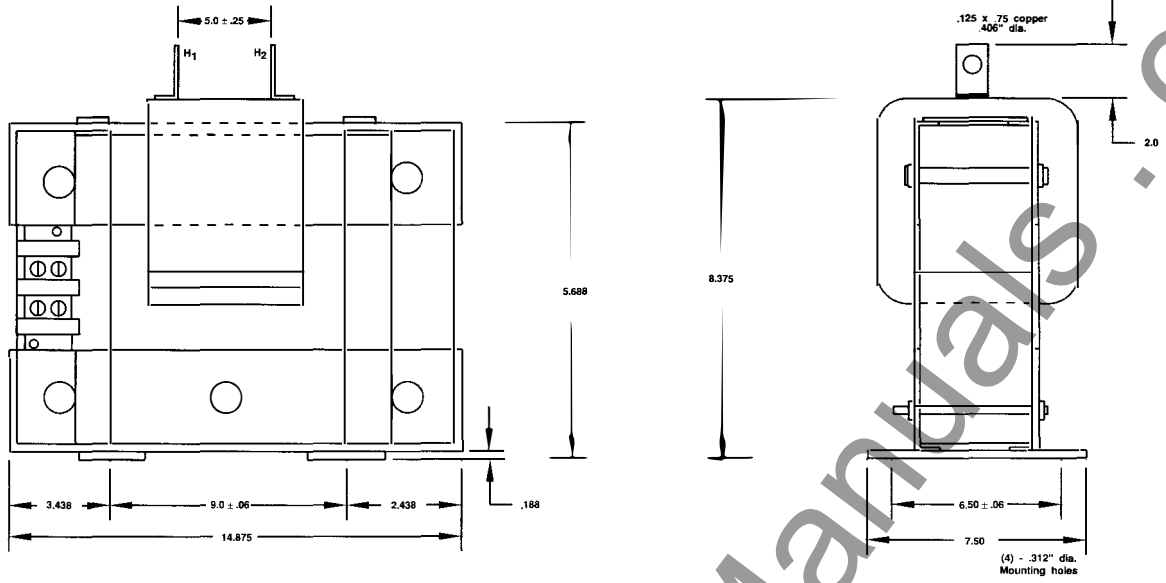

FIGURE 3. OUTLINE DRAWING BE 25925-001.

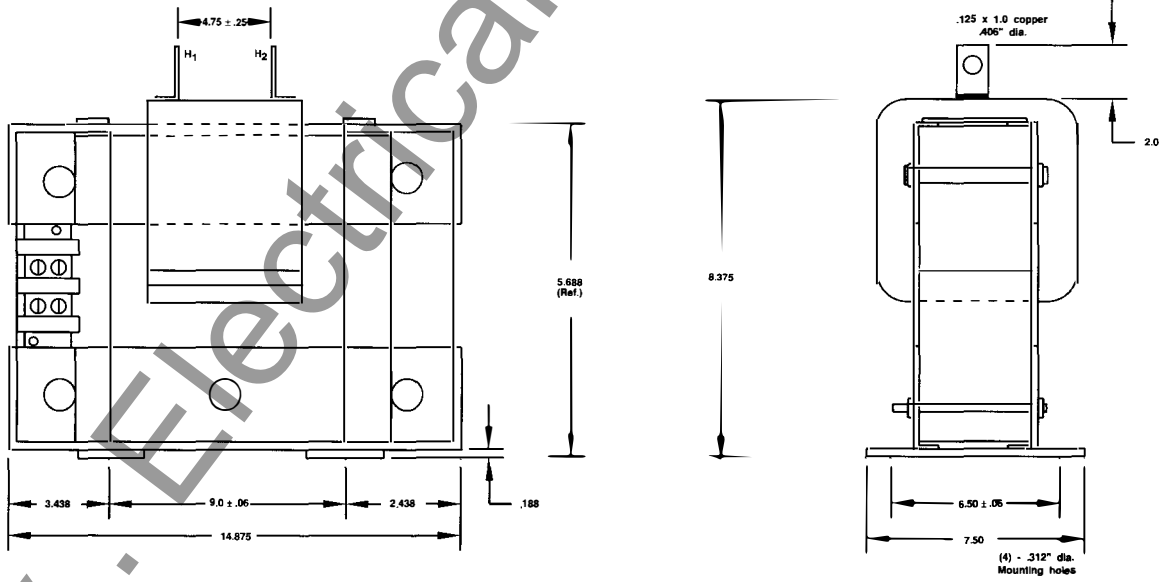

FIGURE 4. OUTLINE DRAWING BE 25926-001.

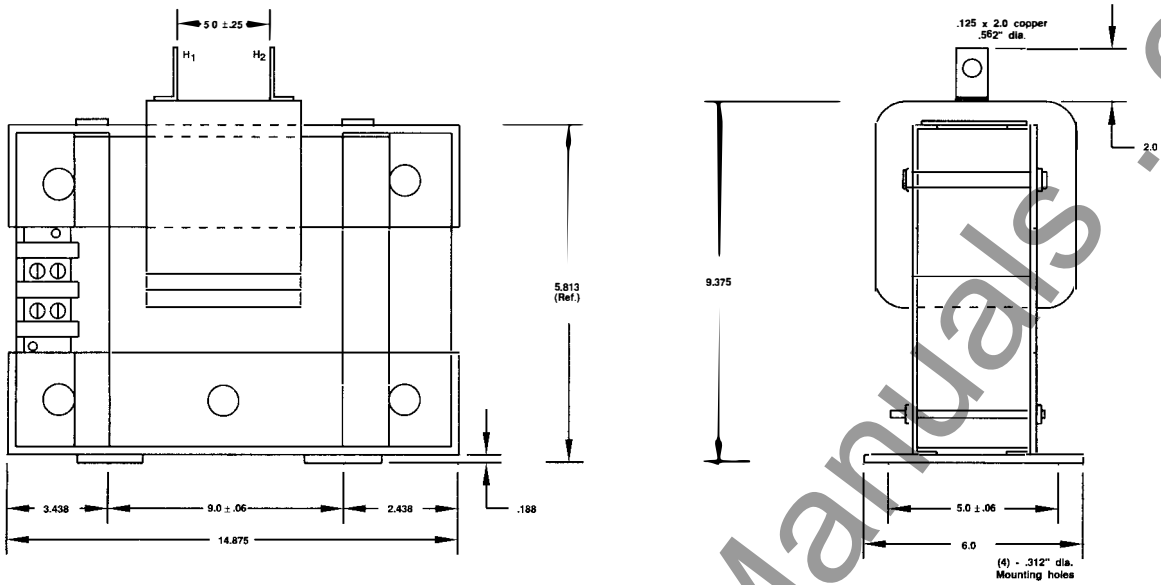

FIGURE 5. OUTLINE DRAWING BE 25927-001.

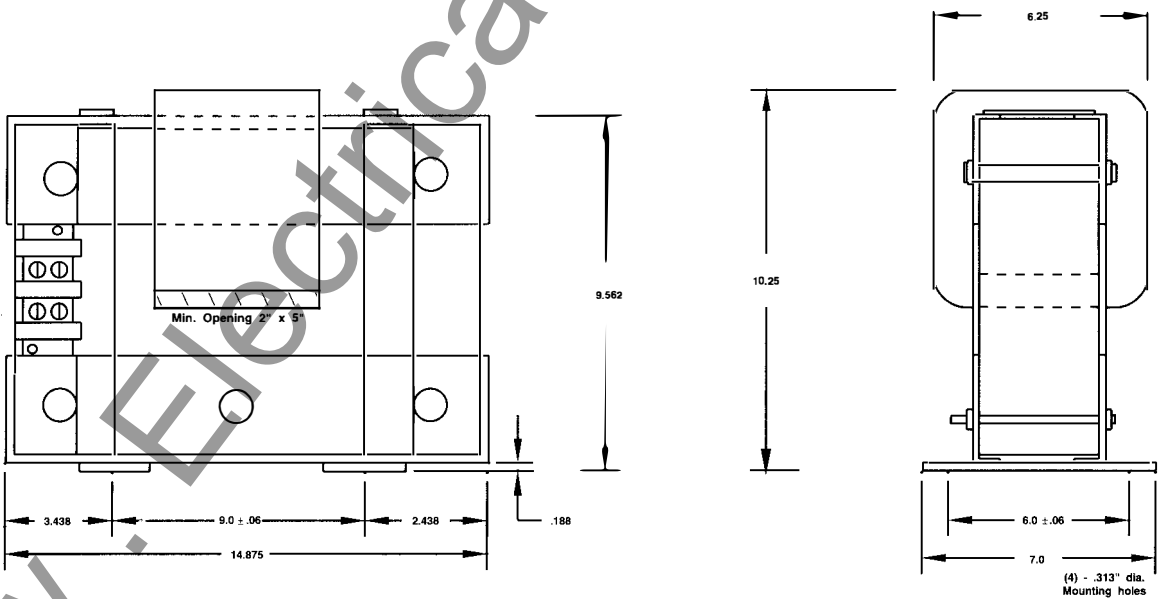

FIGURE 6. OUTLINE DRAWING BE 25928-001.

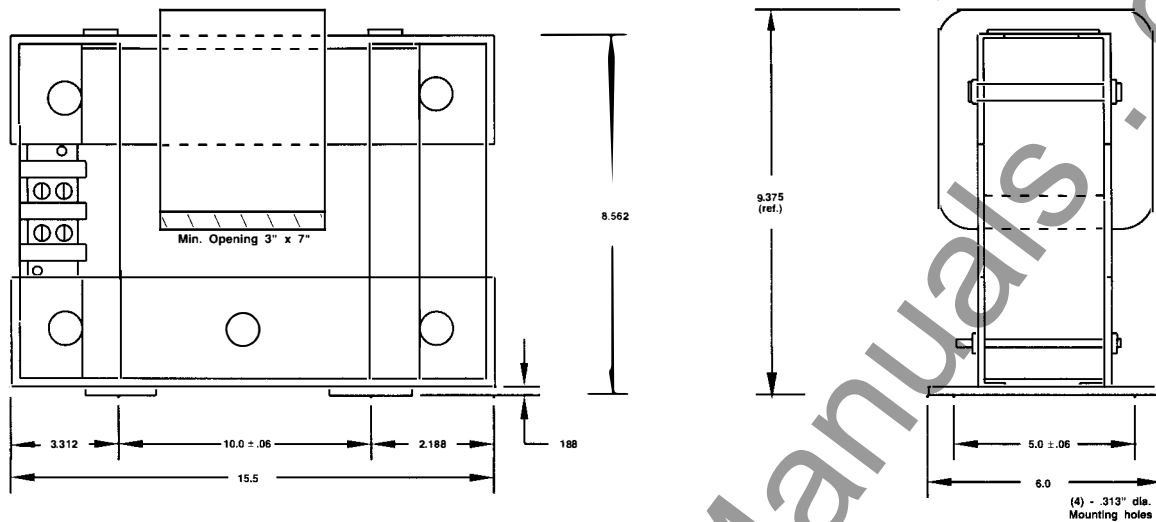

FIGURE 7. OUTLINE DRAWING BE 25929-001.

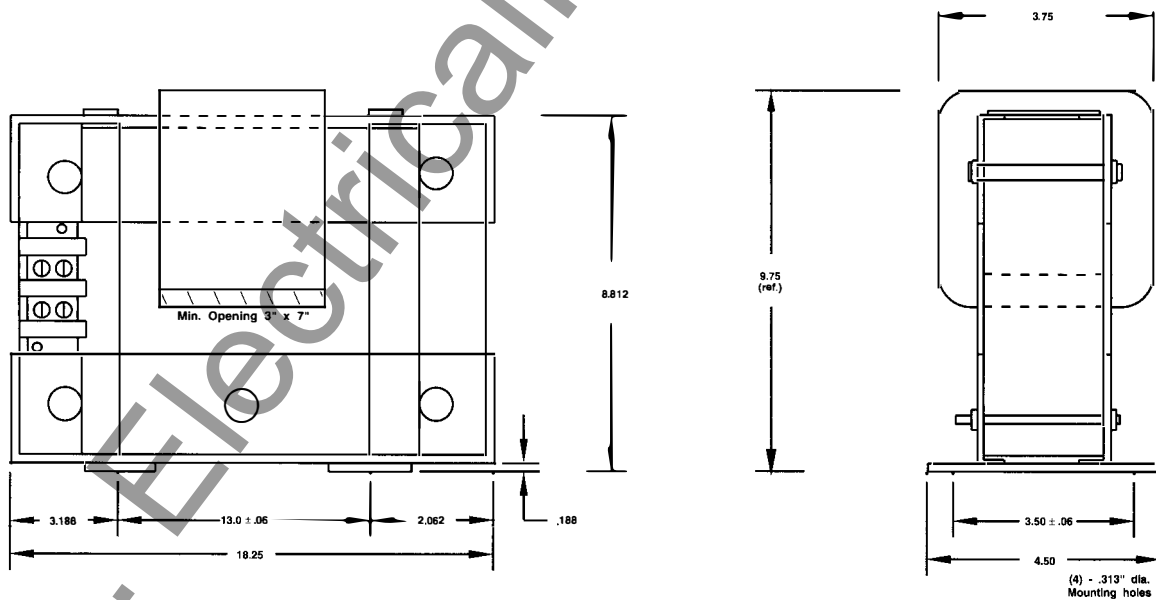

FIGURE 8. OUTLINE DRAWING BE 25930-001.

**B Basler Electric**

