

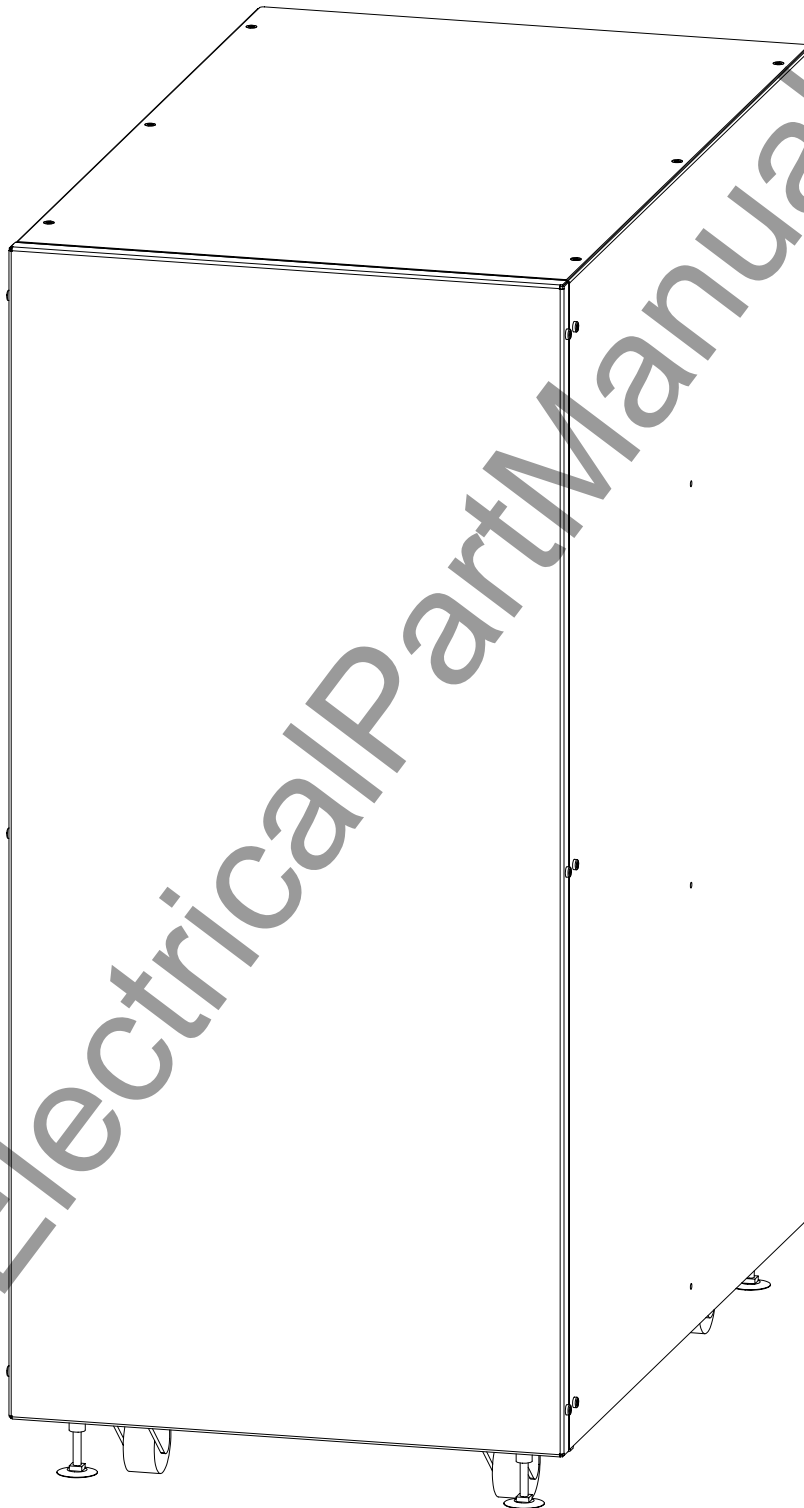

BC11 BATTERY CABINET

INSTALLATION / OPERATION / MAINTENANCE



1. INTRODUCTION	3
2. PRECAUTIONS	3
3. INSPECTION UPON RECEIPT OF GOODS	4
3.1 GENERAL	4
3.2 VISIBLE DAMAGE	4
3.3 CONCEALED DAMAGE	4
3.4 RETURN OF DAMAGED GOODS	4
4. SYSTEM OVERVIEW	5
5. GENERAL SYSTEM SPECIFICATIONS	6
5.1 DC OUTPUT CHARACTERISTICS	6
5.2 BATTERIES	6
5.3 GROUNDING	6
5.4 ENVIRONMENTAL CONDITIONS	6
6. INSTALLATION PROCEDURES	7
6.1 PREPARATION	7
6.1.1 EQUIPMENT INSPECTION	7
6.1.2 NECESSARY EQUIPMENT AND TOOLS	7
6.1.3 SAFETY PRECAUTIONS	7
7. INSTALLATION STEPS	8
7.1 CABINET LOCATION	8
7.2 CABINET MOUNTING	8
7.3 DC CONNECTIONS	8
7.4 GROUNDING	9
7.5 SYSTEM OPERATION	9
8. SYSTEM MAINTENANCE	10
8.1 REPLACING A BLOWN FUSE	10
8.2 BATTERY REPLACEMENT STEPS	10
9. SYSTEM DRAWINGS/SCHEMATICS	10
10. WARRANTY	11

1. INTRODUCTION

C&C Power, Inc.
949 N. Larch Ave.
Elmhurst, IL 60126
www.ccpower.com

C&C Power's BC11 battery cabinet systems are shipped fully assembled, internally pre-wired, and come standard with over current fuse protection. The BC11 battery cabinet is designed to accommodate various battery sizes and configurations, and comes with 2 removable battery trays accessible from the front cover for easy maintenance.

As with all of C&C Power equipment, systems are Hi-Pot tested to UL standards at our facility prior to shipment. All system settings are also adjusted at this time according to the specification sheet attached to the unit or per customer requirements.

Sales support for future equipment or upgrades is provided by our regional sales staff and qualified representatives. All technical questions and service issues should be directed to our main office by dialing the number listed below. This is a 24-hour, 7-day service number. After normal working hours, please leave a detailed message with your phone number on the voice mail system and a qualified service representative will contact you as quickly as possible.

C&C Power, Inc. 949 N. Larch Avenue, Elmhurst, Illinois
Phone: (630)-617-9022; Fax: (630)-617-9023
Emergency Service: (630)-617-9022

2. PRECAUTIONS

It is very important to read, understand and follow the instructions in this manual. Also note all SAFETY PRECAUTIONS before beginning the installation of this system.

If there are any questions, concerns or precautions that are not clearly understood or stated in this manual, contact a C&C Power representative for further clarification.

DC Power and Batteries are dangerous and have extremely high short circuit current. Severe burns or death can result from a system short. They also can leak potentially explosive gas (hydrogen). Never enclose batteries or battery cabinets in a sealed room.

It is imperative that only qualified personnel work on this system and installation, maintenance or upgrades be performed with insulated tools.

When installing this battery system, follow all applicable federal, state and local regulations and industry guidelines to insure a proper installation.

Jewelry and watches must be removed prior to installing or servicing this system.

Never leave a panel off with system unattended.

3. INSPECTION UPON RECEIPT OF GOODS

3.1 General

Special precautions and care have been taken to ensure the system arrives safe and undamaged. However, upon receipt, you should inspect the entire shipment, including the skid and any boxes for evidence of damage that may have occurred during transit.

3.2 Visible Damage

It is the responsibility of the person receiving the shipment to inventory and fully inspect all materials against the bill of lading or weigh bill IMMEDIATELY while the carrier representative is still present. Insure that all items are accounted for, including number of skids and quantity of boxes. Also note any visible external damage that may have occurred during transit. Make all applicable notations on the delivery receipt before signing and file a damage report with the carrier.

3.3 Concealed Damage

Within 3 to 30 days of receipt (depending on courier), unpack the battery system and check for any concealed damage. Check the materials received against the detailed packing list to verify the quantity and the condition as complete and satisfactory.

Note any damage to the internal packaging, then request an inspection by the carrier and file a concealed damage claim. If there is a material shortage, contact a C&C Power representative at the main office to file a claim.

**Please contact your shipping company for all shipping damage.
C&C Power is not responsible for any shipping damage.**

3.4 Return of Damaged Goods

Should equipment be damaged and require return to C&C Power for repair, a representative will provide instructions along with an RMA number to expedite the return.

An RMA number must be obtained before returning equipment to C&C Power, Inc.

4. SYSTEM OVERVIEW

Enclosed battery cabinet systems provide the necessary DC backup power required in UPS and Telecom applications. Over-current fuse protection is supplied standard on the hot side of the system. All DC connections are easily accessible and made via jumper cable with quick connects at the rear of each cabinet. Refer to the attached layout and schematic for these connections.

During normal conditions the UPS or charger supplies the load power and the necessary power required to keep the batteries at the proper float voltage.

When AC fails, the batteries discharge in order to provide the necessary backup power. It is the responsibility of the customer to make sure the batteries are not discharged below manufacturer's recommendations. Always recharge batteries as soon as possible. Batteries will be damaged if not recharged right away. See the UPS or DC system manual for more information.

5. GENERAL SYSTEM SPECIFICATIONS

5.1 DC OUTPUT CHARACTERISTICS (refer to equipment label)

- **Voltage: (Telecom Application)** 48 or 24VDC Nominal
- **Voltage: (UPS Application)** 12 to 360VDC Nominal
- **Fuse:** Supplied on hot side.
- **Wire Size and Type:** Per NEC and/or local building and electrical codes.

5.2 BATTERIES

- **Type:** Valve Regulated Lead Acid (VRLA), sealed, non-spillable
- **Voltage:** 12 Volt or 6 Volt DC Nominal.

5.3 GROUNDING

- All grounding should be derived from the main building ground source.
Note: All battery cabinets require grounding.

5.4 ENVIRONMENTAL CONDITIONS

- **Cabinet Dimensions:**
BC11: 17.9"W X 30.0"D X 40.6"H
For further dimensions, please refer to cabinet layout drawing.
- **Cabinet Weight:(Empty)**
BC11: 128 lbs.
For weight with batteries, please refer to cabinet layout drawing.
- **Temperature:** Normal operating temperatures are between 68°-77°F
Note: This is based on the charger for the batteries. Batteries typically should be at 77°F for optimum life and performance.
- **Ventilation/Cooling:** Cabinet ventilation is through louvers in the rear cover. A minimum clearance of four inches is required behind the cabinet for ventilation and cord clearances. Clearance around this cabinet should be as suggested by NEC and local codes.

**Warning! Batteries can generate potentially explosive gas (hydrogen).
Never enclose batteries or battery cabinets in a sealed, airtight room.**

6. INSTALLATION PROCEDURES

6.1 PREPARATION

6.1.1 Equipment Inspection

Remove the equipment from the packaging material and inspect for any shipping damage that may have been overlooked upon receipt of goods. Verify the system has all components and cables for installations.

6.1.2 Necessary Equipment and Tools

- Heavily insulated assortment of hand tools
- Digital Voltmeter

6.1.3 Safety Precautions

BEFORE PROCEEDING WITH INSTALLATION READ THE FOLLOWING:

DC VOLTAGE WARNING!

Hazardous DC voltages are present in the battery cabinet. This hazard will always be present, even when the battery system is off-line. Accidental short circuit of the positive and negative terminals will cause tremendous currents to flow resulting in severe burns, fire and possible death. Use extreme caution!

IMPORTANT SAFETY INSTRUCTIONS!!

- All disconnecting means should be in the open/off position before servicing.
- All installation drawings and schematics should be reviewed and clearly understood before hooking up this system.
- Only qualified DC power technicians or electricians should attempt to work on and install this equipment.
- All jewelry, rings and watches should be removed when working on this equipment.
- All tool handles and shafts must be heavily insulated with electrical tape or otherwise protected.
- Do not rest any tools or loose cables on top of batteries.
- Make sure all connections are properly torqued and secure.
- Do not smoke or present flames near or around any battery system.
- Always wear safety glasses and gloves and use insulating mats to stand on when working on this system.
- Do not allow bare skin to come into contact with battery cabinet while touching battery terminals, as this could result in an electrical shock.
- Do not install any cable terminations until it has been verified that such a termination will not create a short circuit.

SAVE THESE INSTRUCTIONS!!

7. INSTALLATION STEPS

7.1 CABINET LOCATION

- Prior to installation, verify floor loading requirements and all applicable codes pertaining to the related equipment. Environmental conditions should also be reviewed. Proper ventilating and cooling must be adequate for optimum battery life and performance. A clearance of 4" is recommended at the rear of the cabinet for proper ventilation and cord clearances. Clearance around this cabinet should be as suggested by NEC and local codes. Ambient temperature should be between 68°-77°F.

7.2 CABINET MOUNTING

1. The BC11 is equipped with four casters, two swivel type casters in the front and two rigid type casters in the rear. Roll the cabinet off of the skid with the provided ramp and move the cabinet into the desired location.
2. Lower the four leveling feet located at each corner to stabilize the cabinet and prevent it from moving. If the installation or location requires the cabinet to be bolted to the floor, use the shipping brackets provided or consult C&C Power for other mounting options. Mark the holes of the bracket on the floor. A minimum of four bolts will be required.
3. Move the cabinet out of the way and drill holes for the mounting hardware that is to be used.
4. Move the cabinet back into place, align the holes, lower the leveling feet and tighten the hardware to secure the mounting brackets.
5. Should any drilling be performed on this equipment, make sure all exposed batteries and connections are completely covered using insulated type mats.

7.3 DC CONNECTIONS

CAUTION!!

READ ALL SAFETY PRECAUTIONS BEFORE PROCEEDING

1. Remove the front cover from the cabinet and check for any noticeable problems or damage that may have occurred during shipment.
2. Verify that the fuse is removed from the fuse holder before proceeding.
3. Review the attached installation drawings and schematic prior to making any connections.
4. Check and re-torque internal battery connections, as shipping may have caused these connections to come loose. Proper torque values are noted on the included system schematic drawing and may also be on the battery case.
5. **CAUTION!** Be sure UPS or charging source is disconnected before making the following connections. Take the cord assembly supplied and connect the three loose wires with ring terminals to the UPS or charger source. The cables will be marked, "Positive", "Negative" or "Ground". **CAUTION! DO NOT** plug in the connector box end to the battery cabinet until the loose wires are terminated and secured inside the UPS or charger source. Refer to the UPS or charger manual for wiring an external battery source. Refer to the attached drawing for a single cabinet layout for further assistance.

6. Connect any additional BC11 battery cabinets in the string at this time. To do this, first remove the plates covering the connectors at the rear of each cabinet. Then, using the supplied cords with connector boxes on each end, simply plug-in and attach one end of the cable to one of the rear connectors on each of the BC11 battery cabinets. Secure the connector boxes into place using the single screw provided. Refer to the attached drawing for a multi cabinet layout for further assistance.

7.4 GROUNDING

1. The ground cable is supplied with the cord assembly as stated previously in this manual. Be sure this cable is connected to the main UPS or charger ground source. Refer to the UPS or charger manual for grounding an external battery source.

7.5 SYSTEM OPERATION

1. Refer to the UPS or charger manual for start up and system operation. *DO NOT attempt to adjust the chargers float or equalize voltage settings.
2. Be sure to install the main fuse supplied with the battery cabinet into the fuse holder and press firmly into place. Failure to do so will result in partial loss of critical backup time and reduced battery life.

8. SYSTEM MAINTENANCE

CAUTION!!

READ ALL SAFETY PRECAUTIONS BEFORE PROCEEDING

8.1 REPLACING A BLOWN FUSE

- If the internal fuse has blown, first determine the cause and make sure the problem has been resolved.
- Next, remove the front cover and open the fuse holder. Remove the blown fuse and replace with the same size and type of fuse.
- Close the fuse holder and reinstall the front cover.

Caution! Fire Hazard Warning:

Replace only with same type and rating of fuses supplied with the system.

8.2 BATTERY REPLACEMENT STEPS

1. Prepare the new battery/s for installation.
Check to make sure the battery/s are the same type and amp-hour rating.
Measure the battery voltage to make sure it is ok.
Use a brass wire brush or scotch-brite pad and polish the lead terminals.
Apply No-ox grease to the terminal to avoid corrosion.
2. Disconnect the charger or UPS only from the battery cabinet and string that is to be serviced by removing the main fuse located behind the front cover of the battery cabinet. **DO NOT** disconnect cord assemblies between the UPS and other battery cabinets, as this will result in loss of backup time supplied by other battery cabinets that are connected in parallel with the UPS.
3. Remove the center jumper on the battery string to reduce the voltage. If replacing all batteries, continue reducing the voltage in this manner.
4. Disconnect the cables from the battery/s to be replaced.
5. Remove the bad battery/s.
6. Replace with new battery/s. **Make sure the new battery/s are installed the same way regarding polarity orientation and verify with the system schematic drawing!!** This is very important, if installed improperly it will result in a short circuit and could cause serious injury or death!!
7. Reconnect cables to battery/s. Make sure connections are properly torqued.
8. Reconnect center jumper. Make sure connections are properly torqued.
9. Check voltage at the connectors located at the rear of the cabinet.
10. Reinstall the jumper cable from the UPS at the rear of the cabinet.
11. Reinstall the main fuse and replace front cover.

9. SYSTEM DRAWINGS/SCHEMATICS

See attached documents

10. WARRANTY

LIMITED WARRANTY AND EXCLUSIONS

C & C Power, Inc. strives to produce quality products at reasonable prices. If you are not satisfied with our product because of a defect, we will repair or replace the defective part or parts free of charge for a period of one year from the date of purchase. In the event you claim that the product contains a defect, simply notify C & C Power, Inc. of the defect, and we will arrange for repair or replacement. The sole and exclusive remedy against C & C Power, Inc. relating in any way to a product defect shall be the repair or replacement of defective parts as provided for under this **LIMITED WARRANTY**. No other remedy, including, but not limited to, incidental or consequential damages for lost profits, lost sales, injury to person or property, or any other incidental or consequential loss, is available. This **LIMITED WARRANTY** shall not be deemed to have failed of its essential purpose so long as C & C Power, Inc. is willing and able to repair or replace defective parts in the manner prescribed in this **LIMITED WARRANTY**.

Certain integrated products, which are not manufactured by C&C Power; will be warranted by the applicable manufacturer. These warranties shall be between the manufacturer and the user. Terms and conditions may vary. These integrated products include, but may not be limited to, the following products: Batteries, Inverters and UPS Systems.

Any action for breach relating to the sale of a C & C Power, Inc. product must be commenced within one year after the cause of action has accrued.

THIS **LIMITED WARRANTY** IS IN LIEU OF ANY OTHER WARRANTY, EXPRESS OR IMPLIED, AND ALL SUCH WARRANTIES ARE EXCLUDED, INCLUDING, BUT NOT LIMITED TO, ANY IMPLIED WARRANTY OF MERCHANTABILITY OR FITNESS FOR A PARTICULAR PURPOSE.

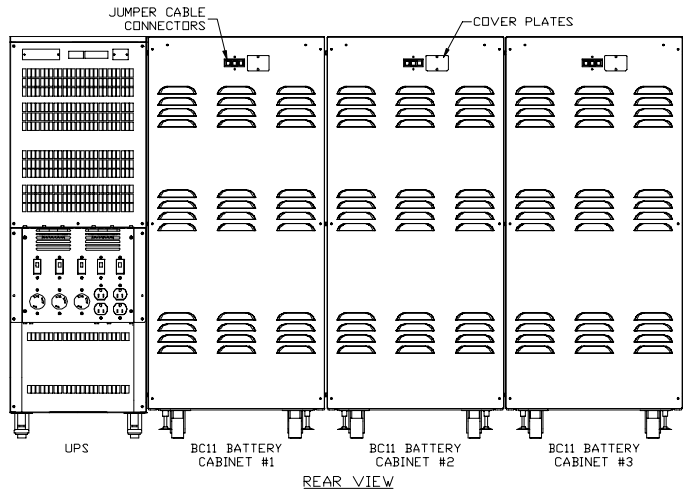

1. MOVE THE CABINET INTO PLACE.

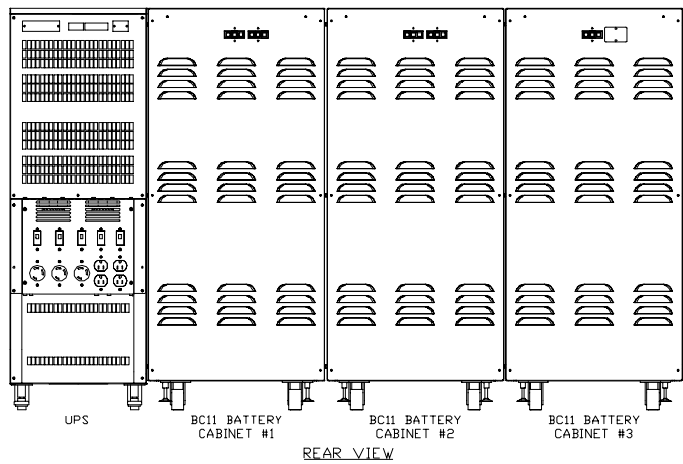

2. REMOVE THE NECESSARY COVER PLATES.

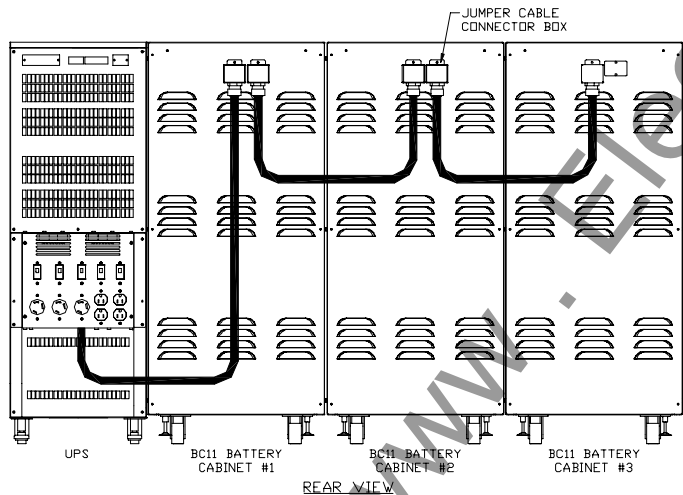
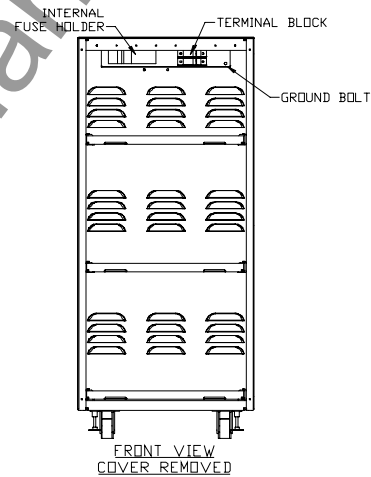

3. CONNECT THE BATTERY CABINET JUMPER CABLES TO THE CABINETS, AND SCREW THE CONNECTOR BOX INTO PLACE.
 4. INSTALL THE JUMPER FROM THE #1 CABINET TO THE UPS. SEE UPS MANUAL FOR INSTRUCTIONS ON HARD WIRING BATTERY CABINETS.

91411		BC11 MULTI CABINET INSTALLATION	
UNLESS OTHERWISE SPECIFIED DIMENSIONS ARE IN INCHES TOLERANCES ARE:		CAD GENERATED DRAWING, DO NOT MANUALLY UPDATE!	
DECIMALS: XX ± 01 .XXX ± 005	ANGLES: XXX ± 1°	APPROVALS DRAWN CH	DATE 10/16/02
MATERIAL	---	CHECKED	RESP ENG
FINISH	---	MFG ENG	
DO NOT SCALE DRAWING	QUAL ENG	SIZE DWG. NO. A	REV. A
		SCALE N.T.S. CAD FILE: ---	SHEET 1 OF 1

C&C POWER, INC.
 949 N. Larch Avenue
 Elmhurst, IL 60126

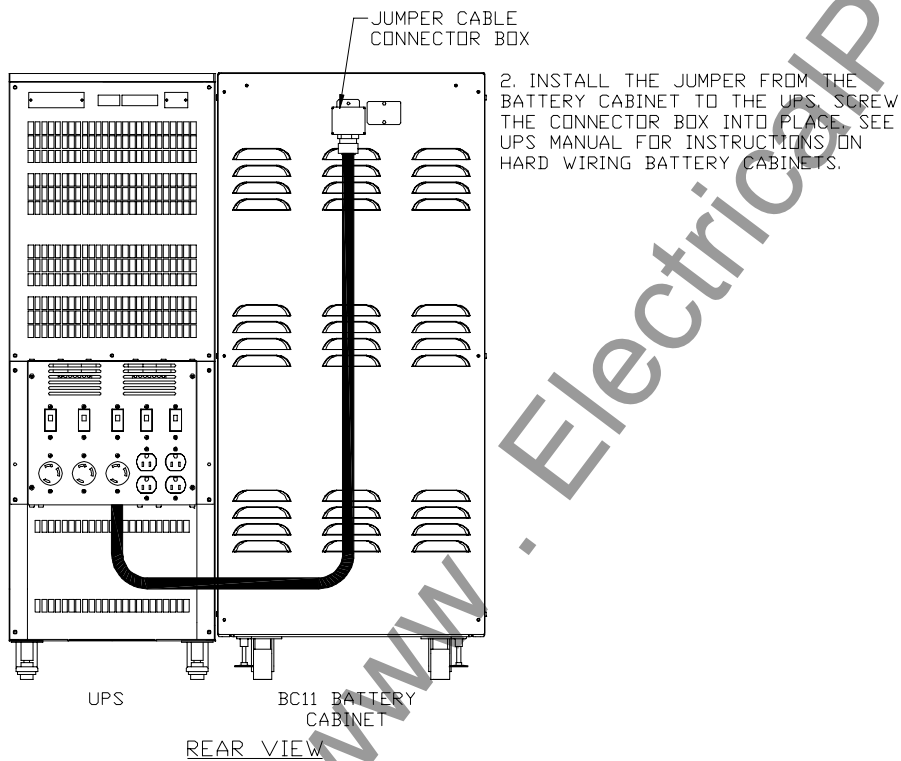
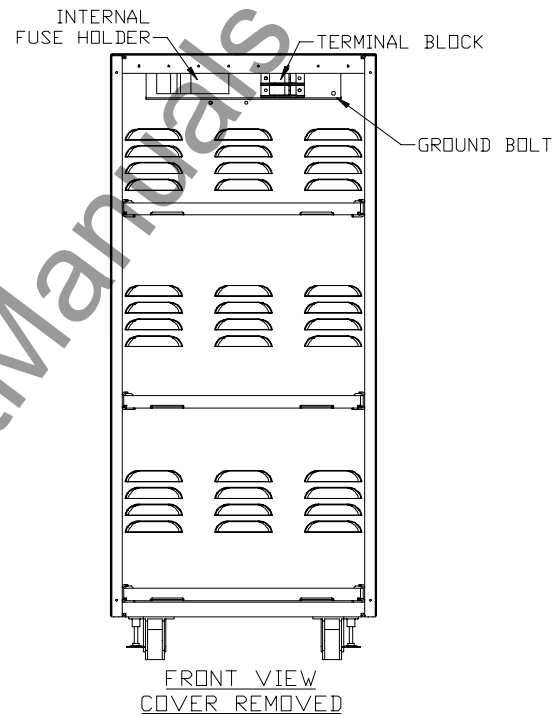
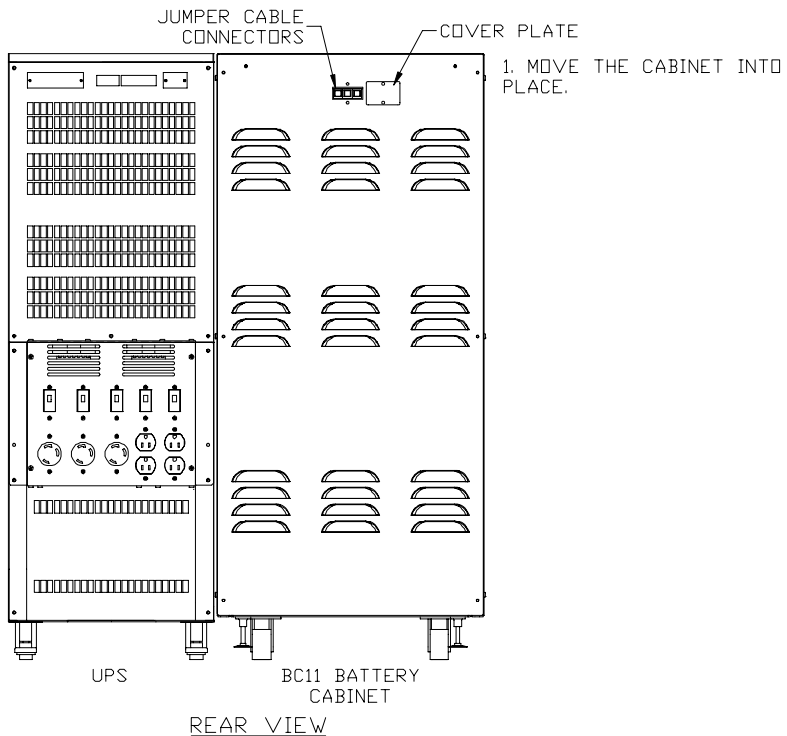

91411		BC11 SINGLE CABINET INSTALLATION	
--		--	
UNLESS OTHERWISE SPECIFIED DIMENSIONS ARE IN INCHES TOLERANCES ARE:		CAD GENERATED DRAWING. DO NOT MANUALLY UPDATE!	
DECIMALS:	ANGLES:	THE INFORMATION CONTAINED IN THIS DRAWING IS THE SOLE PROPERTY OF C&C POWER, INC. ANY REPRODUCTION WITHOUT THE WRITTEN CONSENT OF C&C POWER, INC IS PROHIBITED.	
.XX ±.01	XXX ±1°	APPROVALS	DATE
.XXX ±.005		DRAWN	CH 10/16/02
MATERIAL		CHECKED	
FINISH		RESP ENG	
DO NOT SCALE DRAWING		QUAL ENG	
		 C&C POWER, INC. 949 N. Larch Avenue Elmhurst, IL 60126	
SIZE:	DWG. NO.	SCALE:	REV.
A	--	N.T.S.	A
SHEET:		1 OF 1	

Revisions:

10/16/02 REV1

03/05/04 REV2 Removed note limiting distance to 10 Feet from the UPS

www.ElectricalPartManuals.com