

2005

CABLE TRAY MANUAL

Based on the
2005 National Electrical Code®



Table of Contents

	Page No.
Introduction	2
Why Cable Tray?	
Safety	3
Dependability	4
Space Savings	4
Cost Savings	5-8
An In-depth Look at the 2005 NEC®, Section 392	
Types of Cable Trays (NEC® 392.1 Scope).....	9-11
EMI/RFI Cable Tray	10-11
Cable Tray Materials	12
Types of Cables Allowed in Cable Tray [392.3 (A)].....	12
MI - Mineral Insulated Metal Sheathed Cable [Article 332]	12
MC - Metal Clad Cable [Article 330]	13
TC - Power and Control Tray Cable [Article 336]	13
ITC - Instrumentation Tray Cable [Article 727]	13
PLTC - Power Limited Tray Cable [Sections 725.61 (C) and 725.71 (E)]	14
Other Types - Fire Alarm [Article 760], Multipurpose and Communications Cable [Article 800]	14
Single Conductor & Type MV Cables [392.3 (B)]	14
Cable Tray Use in Hazardous Locations [392.3 (D)].....	15-17
Limitations on Cable Tray Use [392.4]	18
Cable Tray Loading [392.5 (A)].....	18-20
Fiberglass Cable Tray [392.3 (E) & 392.5 (F)]	20
Discontinuous Cable Tray and Fittings [392.6 (A)]	21-22
Covers [392.6 (D)].....	23
Barriers [392.6 (E) & (F)].....	24
Spacing of Multiple Cable Trays [392.6 (I)]	25
Supporting Conduit from Cable Tray [392.6 (J)]	25
Use of Cable Tray as an Equipment Grounding Conductor [392.7 Grounding]	26-29
Fastening Cables [392.8 (B)]	30
Cable Installation [392.8]	30-32
Sizing Cable Tray	
Multiconductor - 2000 volts or less [392.9]	32-34
Single conductor - 2000 volts or less [392.10].....	34-36
Type MC or MV - 2001 volts or greater [392.12]	37
Ampacities of Cables in Cable Tray	36-38
Cable Tray Wiring System Design and Installation Hints	38-39
Fireproofing Tray	40
Expansion and Contraction	41-42
Appendix Index & Appendix Sheets	44-55
Cable Tray Installation & Specification Checklists	54-55
Footnotes	56

INTRODUCTION

The B-Line Cable Tray Manual was produced by B-Line's technical staff. B-Line has recognized the need for a complete cable tray reference source for electrical engineers and designers. The following pages address the 2005 **National Electric Code**® requirements for cable tray systems as well as design solutions from practical experience. The information has been organized for use as a reference guide for both those unfamiliar and those experienced with cable tray.

Nearly every aspect of cable tray design and installation has been explored for the use of the reader. If a topic has not been covered sufficiently to answer a specific question or if additional information is desired, contact the engineering department at B-Line. We sincerely hope you will find the B-Line Cable Tray Manual a helpful and informative addition to your technical library.

The information contained herein has been carefully checked for accuracy and is believed to be correct and current. No warranty, either expressed or implied, is made as to either its applicability to, or its compatibility with, specific requirements, of this information, nor for damages consequent to its use. All design characteristics, specifications, tolerances and similar information are subject to change without notice.

Cooper B-Line, Inc.
509 West Monroe Street
Highland, IL 62249-0326
Tel: (618) 654-2184
Fax: (618) 654-5499

National Electrical Code® and **NEC**® are registered trademarks of the
National Fire Protection Association, Inc. Quincy, MA 02269.

WHY CABLE TRAY?

BECAUSE A CABLE TRAY WIRING SYSTEM PROVIDES SAFE AND DEPENDABLE WAYS TO SAVE NOW AND LATER

Large numbers of electrical engineers have limited detail knowledge concerning wiring systems. There is the tendency by engineers to avoid becoming involved in the details of wiring systems, leaving the wiring system selection and design to designers or contractors. Certain decisions must be made for any wiring system installation, and these decisions should be made in the design and construction activities' chain where maximum impact is achieved at the lowest possible cost. Deferring design decisions to construction can result in increased costs and wiring systems incompatible with the owner's future requirements. Early in the project's design life, the costs and features of various applicable wiring systems should be objectively evaluated in detail. Unfortunately, such evaluations are often not made because of the time and money involved. It is important to realize that these initial evaluations are important and will save time and money in the long run. The evaluation should include the safety, dependability, space and cost requirements of the project. Many industrial and commercial electrical wiring systems have excessive initial capital costs, unnecessary power outages and require excessive maintenance. Moreover, the wiring system may not have the features to easily accommodate system changes and expansions, or provide the maximum degree of safety for the personnel and the facilities.

Cable tray wiring systems are the preferred wiring system when they are evaluated against equivalent conduit wiring systems in terms of safety, dependability, space and cost. To properly evaluate a cable tray wiring system vs. a conduit wiring system, an engineer must be knowledgeable of both their installation and the system features. The advantages of cable tray installations are listed below and explained in the following paragraphs.

- Safety Features
- Dependability
- Space Savings
- Cost Savings
- Design Cost Savings
- Material Cost Savings
- Installation Cost & Time Savings
- Maintenance Savings

CABLE TRAY SAFETY FEATURES

A properly engineered and installed cable tray wiring system provides some highly desirable safety features that are not obtainable with a conduit wiring system.

- Tray cables do not provide a significant path for the transmission of corrosive, explosive, or toxic gases while conduits do. There have been explosions in industrial facilities in which the conduit systems were a link in the chain of events that set up the conditions for the explosions. These explosions would not have occurred with a cable tray wiring system since the explosive gas would not have been piped into a critical area. This can occur even though there are seals in the conduits. There does have to be some type of an equipment failure or abnormal condition for the gas to get into the conduit, however this does occur. Conduit seals prevent explosions from traveling down the conduit (pressure piling) but they do not seat tight enough to prevent moisture or gas migration until an explosion or a sudden pressure increase seats them. The October 6, 1979 Electrical Substation Explosion at the Cove Point, Maryland Columbia Liquefied Natural Gas Facility is a very good example of where explosive gas traveled through a two hundred foot long conduit with a seal in it. The substation was demolished, the foreman was killed and an operator was badly burned. This explosion wouldn't have occurred if a cable tray wiring system had been installed instead of a conduit wiring system. A New Jersey chemical plant had the instrumentation and electrical equipment in one of its control rooms destroyed in a similar type incident.

- In addition to explosive gases, corrosive gases and toxic gases from chemical plant equipment failures can travel through the conduits to equipment or control rooms where the plant personnel and the sensitive equipment will be exposed to the gases.

- In facilities where cable tray may be used as the equipment grounding conductor in accordance with **NEC**® Sections 392.3(C) & 392.7, the grounding equipment system components lend themselves to visual inspection as well as electrical continuity checks.

CABLE TRAY DEPENDABILITY

A properly designed and installed cable tray system with the appropriate cable types will provide a wiring system of outstanding dependability for the control, communication, data handling, instrumentation, and power systems. The dependability of cable tray wiring systems has been proven by a 40 year track record of excellent performance.

- Cable tray wiring systems have an outstanding record for dependable service in industry. It is the most common industrial wiring system in Europe. In continuous process systems, an electrical system failure can cost millions of dollars and present serious process safety problems for the facility, its personnel and the people in the surrounding communities. A properly designed and installed cable tray system with the appropriate cable types will provide a wiring system of outstanding dependability for process plants.

- Television broadcast origination facilities and studios make use of cable tray to support and route the large volumes of cable needed for their operations with a high degree of dependability. It would be impossible to have the wiring system flexibility they need with a conduit wiring system.

- Large retail and warehouse installations use cable tray to support their data communication cable systems. Such systems must be dependable so that there are no outages of their continuous inventory control systems.

- Cable tray wiring systems have been widely used to support cabling in both commercial and industrial computer rooms overhead and beneath the floor to provide orderly paths to house and support the cabling. These types of installations need a high degree of dependability which can be obtained using cable tray wiring systems.

CABLE TRAY SPACE SAVINGS

When compared to a conduit wiring system, an equivalent cable tray wiring system installation requires substantially less space.

Increasing the size of a structure or a support system to handle a high space volume conduit wiring system is unnecessary when this problem can be avoided by the selection of a cable tray wiring system.

- Facilities with high density wiring systems devoted to control, instrumentation, data handling and branch circuit wiring have the choice of selecting cable tray or conduit wiring systems. A conduit wiring system is often a poor choice because large conduit banks require significant space, competing with other systems and equipment. Choosing a cable tray wiring system greatly reduces this problem.

- Financial institutions with large computer installations have high density wiring systems under floors or in overhead plenum areas that are best handled by cable tray wiring systems.

- Airport facilities have extensive cable tray wiring systems to handle the ever expanding needs of the airline industry.

- Cable tray is used in many facilities because of the ever present need of routing more and more cables in less space at lower costs.

- Large health care facilities have high density wiring systems that are ideal candidates for cable tray.

CABLE TRAY WIRING SYSTEM COST SAVINGS

Usually, the initial capital cost is the major factor in selecting a project's wiring system when an evaluation is made comparing cable tray wiring systems and conduit wiring systems. Such an evaluation often covers just the conductors, material, and installation labor costs. The results of these initial cost evaluations usually show that the installed cable tray wiring system will cost 10 to 60 percent less than an equivalent conduit wiring system. The amount of cost savings depends on the complexity and size of the installation.

There are other savings in addition to the initial installation cost savings for cable tray wiring systems over conduit wiring systems. They include reduced engineering costs, reduced maintenance costs, reduced expansion costs, reduced production losses due to power outages, reduced environmental problems due to continuity of power and reduced data handling system costs due to the continuity of power. The magnitudes of many of these cost savings are difficult to determine until the condition exists which makes them real instead of potential cost savings.

DESIGN COST SAVINGS

- Most projects are roughly defined at the start of design. For projects that are not 100 percent defined before design start, the cost of and time used in coping with continuous changes during the engineering and drafting design phases will be substantially less for cable tray wiring systems than for conduit wiring systems. A small amount of engineering is required to change the width of a cable tray to gain additional wiring space capacity. Change is a complex problem when conduit banks are involved.

- The final drawings for a cable tray wiring system may be completed and sent out for bid or construction more quickly than for a conduit wiring system. Cable tray simplifies the wiring system design process and reduces the number of details.

- Cable tray wiring systems are well suited for computer aided design drawings. A spread sheet based wiring management program may be used to control the cable fills in the cable tray. While such a system may also be used for controlling conduit fill, large numbers of individual conduits must be

monitored. For an equal capacity wiring system, only a few cable tray runs would have to be monitored.

- Dedicated cable tray installation zones alert other engineering disciplines to avoid designs that will produce equipment and material installation conflicts in these areas. As more circuits are added, the cable tray installation zone will increase only a few inches; the space required for the additional conduits needed would be much greater.

- **The fact that a cable can easily enter and exit cable tray anywhere along its route**, allows for some unique opportunities that provide highly flexible designs.

- Fewer supports have to be designed and less coordination is required between the design disciplines for the cable tray supports compared to conduit supports.

MATERIAL COST SAVINGS

- Excluding conductors, the cost of the cable trays, supports, and miscellaneous materials will provide a savings of up to 80% as compared to the cost of the conduits, supports, pull boxes, and miscellaneous materials. An 18 inch wide cable tray has an allowable fill area of 21 square inches. It would take 7 - 3 inch conduits to obtain this allowable fill area (7×2.95 square inches = 20.65 square inches).

- The cost of 600 volt insulated multiconductor cables listed for use in cable tray is greater than the cost of 600 volt insulated individual conductors used in conduit. The cost differential depends on the insulation systems, jacket materials and cable construction.

- For some electrical loads, parallel conductors are installed in conduit and the conductors must be derated, requiring larger conductors to make up for the deration. If these circuits were installed in cable tray, the conductor sizes would not need to be increased since the parallel conductor derating factors do not apply to three conductor or single conductor cables in cable tray.

- Typical 300 volt insulated multiconductor instrumentation tray cables (ITC) and power limited tray cables (PLTC) cost the same for both cable tray and conduit wiring systems. This applies for instrumentation circuits, low level analog and digital

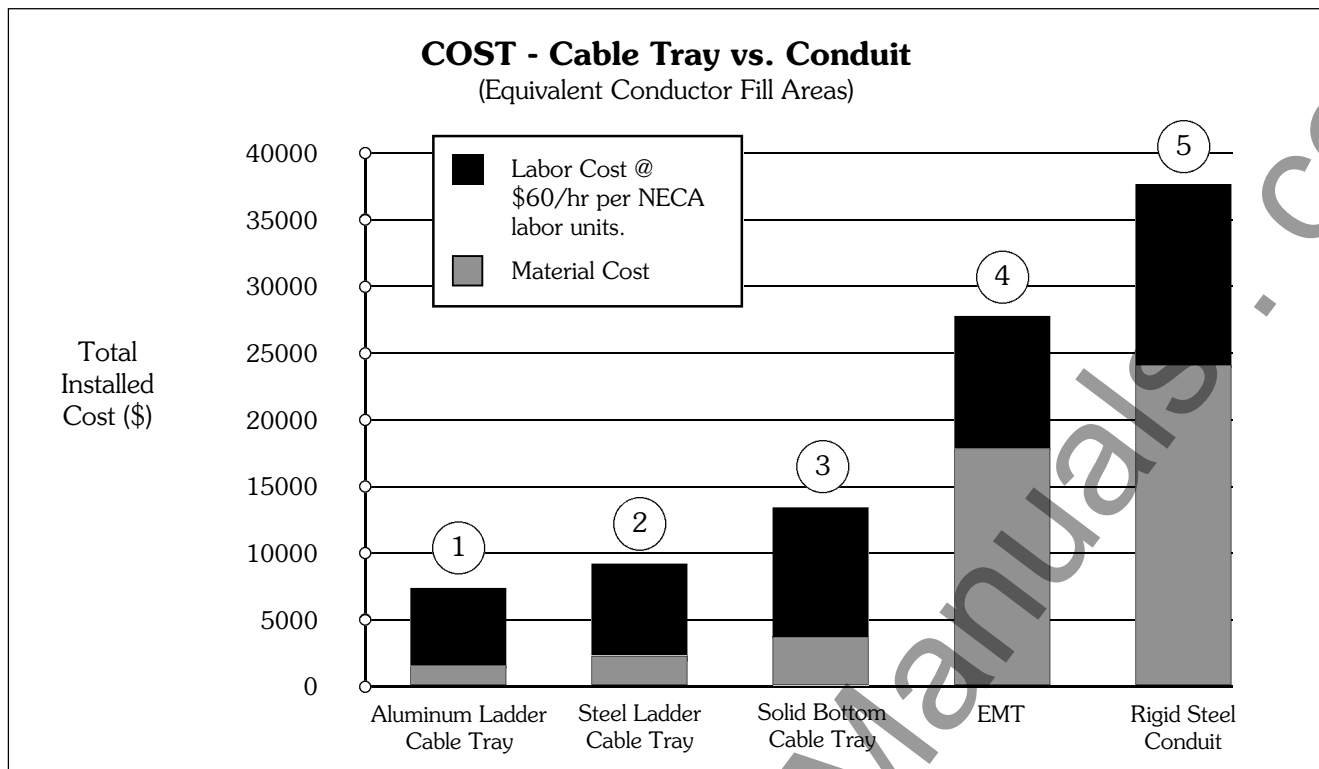

Installation: 200 linear feet of cable supported with four 90° direction changes and all trapeze supports on 8 ft. spans.

1. Aluminum, 18" wide, ladder cable tray (9" rung spacing) with all hardware.
2. Hot dip galvanized steel, 18" wide, ladder cable tray (9" rung spacing) with all hardware.
3. Hot dip galvanized steel, 18" wide, solid bottom cable tray and all hardware.
4. 7 parallel runs of 3" diameter EMT with concentric bends.
5. 7 parallel runs of 3" diameter galvanized conduit with concentric bends.

Note: Above costs do not include cable and cable pulling costs. Cable costs differ per installation and cable/conductor pulling costs have been shown to be considerably less for cable tray than for conduit.

signal circuits, logic input/output (I/O) circuits, etc. There are other cable tray installations which require a higher cost cable than the equivalent conduit installation. Such installations are limited to areas where low smoke emission and/or low flame spread ITC or PLTC cables must be used.

- Conduit banks often require more frequent and higher strength supports than cable trays. 3 inch and larger rigid metal conduits are the only sizes allowed to be supported on 20 foot spans [National Electrical Code® (NEC®) Table 344.30(B)(2)].

- When a cable tray width is increased 6 inches, the cable tray cost increase is less than 10 percent. This substantially increases the cable tray's wiring capacity for a minimal additional cost. To obtain such an increase in capacity for a conduit wiring system would be very costly.

INSTALLATION COST AND TIME SAVINGS

- Depending on the complexity and magnitude of the wiring system, the total cost savings for the initial installation (labor, equipment and material) may be up to 75 percent for a cable tray wiring system over a conduit wiring system. When there are banks of conduit to be installed that are more than 100 feet long and consist of four or more 2 inch conduits or 12 or more smaller conduits, the labor cost savings obtained using cable tray wiring systems are very significant.

- Many more individual components are involved in the installation of a conduit system and its conductors compared to the installation of a cable tray system and its cables. This results in the handling and installing of large amounts of conduit items vs. small amounts of cable tray items for the same wiring capacity.

- The higher the elevation of the wiring system, the more important the number of components required to complete the installation. Many additional man-hours will be required just moving the components needed for the conduit system up to the work location.

- Conduit wiring systems require pull boxes or splice boxes when there is the equivalent of more than 360 degrees of bends in a run. For large conductors, pull or junction boxes may be required more often to facilitate the conductor's installation. Cable tray wiring systems do not require pull boxes or splice boxes.

- Penetrating a masonry wall with cable tray requires a smaller hole and limited repair work.

- More supports are normally required for rigid steel conduit due to the requirements of **NEC**[®] Table 344.30(B)(2).

- Concentric conduit bends for direction changes in conduit banks are very labor intensive and difficult to make. However if they are not used, the installation will be unattractive. The time required to make a concentric bend is increased by a factor of 3-6 over that of a single shot bend. This time consuming practice is eliminated when cable tray wiring systems are used.

- Conductor pulling is more complicated and time consuming for conduit wiring systems than for cable tray wiring systems. Normally, single conductor wire pulls for conduit wiring systems require multiple reel setups. For conduit wiring systems, it is necessary to pull from termination equipment enclosure to termination equipment enclosure. Tray cables being installed in cable trays do not have to be pulled into the termination equipment enclosures. Tray cable may be pulled from near the first termination enclosure along the cable tray route to near the second termination enclosure. Then, the tray cable is inserted into the equipment enclosures for termination. For projects with significant numbers of large conductors terminating in switchgear, this may be a very desirable feature that can save hours of an electrician's time. Unnecessary power outages can be eliminated since tray cable pulls may be made without de-energizing the equipment. For conduit installations, the equipment will have to be de-energized for rubber safety blanketing to be installed, otherwise the conductor pulls might have

to be made on a weekend or on a holiday at premium labor costs to avoid shutting down production or data processing operations during normal working hours.

- Conductor insulation damage is common in conduits since jamming can occur when pulling the conductors. Jamming is the wedging of conductors in a conduit when three conductors lay side by side in a flat plane. This may occur when pulling around bends or when the conductors twist. Ninety-two percent of all conductor failures are the result of the conductor's insulation being damaged during the conductor's installation. Many common combinations of conductors and conduits fall into critical jam ratio values. Critical jam ratio (J.R.= Conduit ID/Conductor OD) values range from 2.8 to 3.2. The J. R. for 3 single conductor THHN/THWN insulated 350 kcmil conductors in a 2¹/₂ inch conduit would be 3.0 (2.469 inches/ 0.816 inches). If conductor insulation damage occurs, additional costs and time are required for replacing the conductors. This cannot occur in a cable tray wiring system.

- Smaller electrician crews may be used to install the equivalent wiring capacity in cable tray. This allows for manpower leveling, the peak and average crew would be almost the same number, and the electrician experience level required is lower for cable tray installations.

- Since the work is completed faster there is less work space conflict with the other construction disciplines. This is especially true if installations are elevated and if significant amounts of piping are being installed on the project.

MAINTENANCE SAVINGS

- One of the most important features of cable tray is that tray cable can easily be installed in existing trays if there is space available. Cable tray wiring systems allow wiring additions or modifications to be made quickly with minimum disruption to operations. Any conceivable change that is required in a wiring system can be done at lower cost and in less time for a cable tray wiring system than for a conduit wiring system.

- Moisture is a major cause of electrical equipment and material failures. Breathing due to temperature cycling results in the conduits accumulating relatively large amounts of moisture. The conduits then pipe this moisture into the electrical equipment enclosures which over a period of time results in the deterioration of the equipment insulation systems and their eventual failure. Also, moisture may become a factor in the corrosion failure of some of the critical electrical equipment's metallic components. Conduit seals are not effective in blocking the movement of moisture. The conduit systems may be designed to reduce the moisture problems but not to completely eliminate it. Few designers go into the design detail necessary to reduce the effects of moisture in the conduit systems. Tray cables do not provide internal moisture paths as do conduits.

- In the event of external fires in industrial installations, the damage to the tray cable and cable tray is most often limited to the area of the flame contact plus a few feet on either side of the flame contact area. For such a fire enveloping a steel conduit bank, the steel conduit is a heat sink and the conductor insulation will be damaged for a considerable distance inside the conduit. Thermoplastic insulation may be fused to the steel conduit and the conduit will need to be replaced for many feet. This occurred in an Ohio chemical plant and the rigid steel conduits had to be replaced for 90 feet. Under such conditions, the repair cost for fire damage would normally be greater for a conduit wiring system than for cable tray and tray cable. In the Ohio chemical plant fire, there were banks of conduits and runs of cable tray involved. The cable tray wiring systems were repaired in two days. The conduit wiring systems were repaired in six days and required a great deal more manpower.

- In the event of an external fire, the conduit becomes a heat sink and an oven which decreases the time required for the conductor insulation systems to fail. The heat decomposes the cable jackets and the conductor insulation material. If these materials contain PVC as do most cables, hydrogen chloride vapors will come out the ends of the conduits in the control rooms. These fumes are very corrosive to the electronic equipment. They are also hazardous to personnel. A flame impingement on a cable tray system will not result in the fumes going into the control room as there is no containment path for them. They will be dispersed into the atmosphere.

IN MOST CASES AN OBJECTIVE EVALUATION OF THE REQUIREMENTS FOR MOST HIGH DENSITY WIRING SYSTEMS WILL SHOW THAT A CABLE TRAY WIRING SYSTEM PROVIDES A WIRING SYSTEM SUPERIOR TO A CONDUIT WIRING SYSTEM.

Abandoned Cables

Easily identified, marked, or removed - all possible from an open Cable Tray System

For the 2002 *National Electrical Code*, several proposals were submitted to the NFPA to revise the 1999 **NEC**[®] for Articles 300, 640, 645, 725, 760, 770, 800, 820, and 830 to require all abandoned cables to be removed from plenum spaces.

The purpose of the proposals is to remove the cables as a source of excess combustibles from plenums and other confined spaces such as raised floors and drop ceilings. All of the Code Making Panels agreed that this should be acceptable practice except Code Making Panel 3, which oversees Article 300.

Because Article 300 is exempt from this requirement only low-voltage and communication cables are affected.

Each Article adopted a definition of abandoned cables and the rule for removal. The general consensus is that abandoned cable is cable that is not terminated at equipment or connectors and is not identified for future use with a tag. Please refer to each individual **NEC**[®] Article for specifics.

Having to tag, remove, or rearrange cables within an enclosed raceway can be a time consuming and difficult job. Without being able to clearly see the cables and follow their exact routing throughout a facility, identifying abandoned cables would be very difficult and expensive.

With the open accessibility of cable tray, these changes can be implemented with ease. Abandoned cables can be identified, marked, rearranged, or removed with little or no difficulty.

AN IN-DEPTH LOOK AT 2005 NEC®

ARTICLE 392 - CABLE TRAY

(The following code explanations are to be used with a copy of the 2005 NEC®.)

To obtain a copy of the NEC® contact:
National Fire Protection Association®
1 Batterymarch Park • P.O. Box 9101
Quincy, Massachusetts 02269-9101
1-800-344-3555

392.1. Scope.

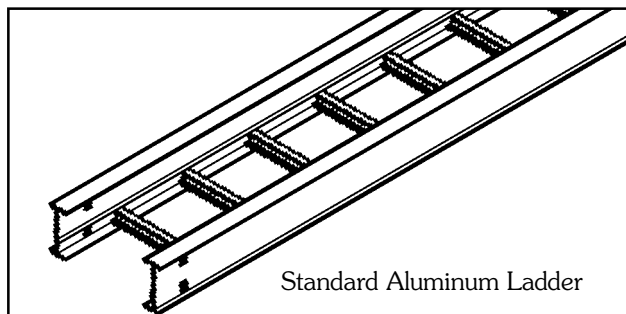

Of the types of cable trays listed in this section, ladder cable tray is the most widely used type of cable tray due to several very desirable features.

- The rungs provide a convenient anchor for tying down cables in vertical runs or where the positions of the cables must be maintained in horizontal runs.
- Cables may exit or enter through the top or the bottom of the tray.
- A ladder cable tray without covers provides for the maximum free flow of air, dissipating heat produced in current carrying conductors.
- Moisture cannot accumulate in ladder cable trays and be piped into electrical equipment as happens in conduit systems.
- Ladder cable tray cannot pipe hazardous or explosive gasses from one area to another as happens with conduit systems.
- In areas where there is the potential for dust to accumulate, ladder cable trays should be installed. The dust buildup in ladder cable trays will be less than the dust buildup in ventilated trough or solid bottom cable trays.

Ladder cable trays are available in widths of 6, 9, 12, 18, 24, 30, 36, and 42 inches with rung spacings of 6, 9, 12, or 18 inches. Wider rung spacings and wider cable tray widths decrease the

overall strength of the cable tray. Specifiers should be aware that some cable tray manufacturers do not account for this load reduction in their published cable tray load charts. B-Line uses stronger rungs in wider cable trays to safely bear the loads published.

With one exception, the specifier selects the rung spacing that he or she feels is the most desirable for the installation. The exception is that 9 inches is the maximum allowable rung spacing for a ladder cable tray supporting any 1/0 through 4/0 single conductor cables [See Section 392.3(B)(1)(a)].

Where the ladder cable tray supports small diameter multiconductor control and instrumentation cables; 6, 9, or 12 inch rung spacings should be specified. Quality Type TC, Type PLTC, or Type ITC small diameter multiconductor control and instrumentation cables will not be damaged due to the cable tray rung spacing selected, but the installation may not appear neat if there is significant drooping of the cables between the rungs.

For ladder cable trays supporting large power cables, 9 inch or wider rung spacings should be selected. For many installations, the cable trays are routed over the top of a motor control center (MCC) or switchgear enclosure. Cables exit out the bottom of the cable trays and into the top of the MCC or switchgear enclosure. For these installations, the cable manufacturer's recommended minimum bending radii for the specific cables must not be violated. If the rung spacing is too close, it may be necessary to remove some rungs in order to maintain the proper cable bending radii. This construction site modification can usually be avoided by selecting a cable tray with 12 or 18 inch rung spacing.

If you are still uncertain as to which rung spacing to specify, 9 inch rung spacing is the most common and is used on 80% of the ladder cable tray sold.

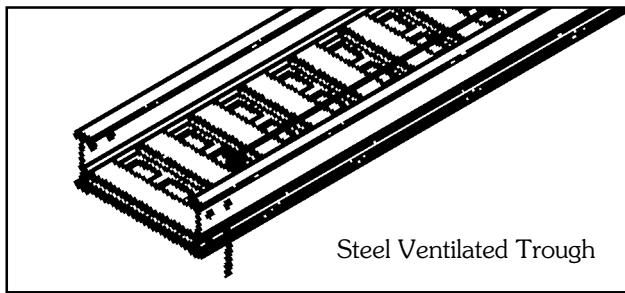

Steel Ventilated Trough

The 1999 **NEC**[®] added the word 'ventilated' in front of trough to clear up some confusion that solid trough is treated the same as ventilated trough. It is not. Solid trough is recognized as solid bottom cable tray.

Ventilated trough cable tray is often used when the specifier does not want to use ladder cable tray to support small diameter multiconductor control and instrumentation cables. As no drooping of the small diameter cables is visible, ventilated trough cable trays provide neat appearing installations. Small diameter cables may exit the ventilated trough cable tray through the bottom ventilation holes as well as out the top of the cable tray. For installations where the cables exit the bottom of the cable tray and the system is subject to some degree of vibration, it is advisable to use B-Line Trough Drop-Out Bushings (Cat. No. 99-1124). These snap-in bushings provide additional abrasion protection for the cable jackets. Just as for ladder cable tray, ventilated trough cable tray will not pipe moisture into electrical equipment.

Standard widths for ventilated trough cable tray systems are 6, 9, 12, 18, 24, 30, and 36 inches. The standard bottom configuration for ventilated trough cable tray is a corrugated bottom with 2 7/8 inch bearing surfaces - 6 inches on centers and 2 1/4 inch x 4 inch ventilation openings. Since a corrugated bottom cannot be bent horizontally, the standard bottom configuration for horizontal bend fittings consists of rungs spaced on 4 inch centers. This difference in bottom construction may be objectionable to some owners, so be sure you are aware of the owner's sensitivity to aesthetics for the cable tray installation.

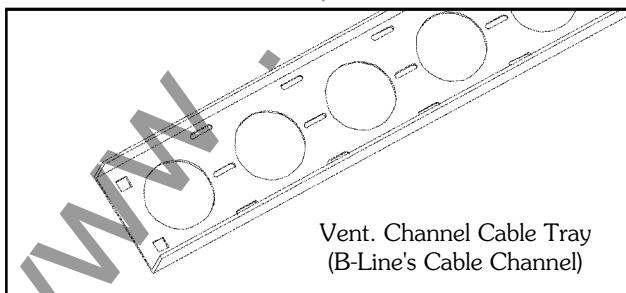

Vent. Channel Cable Tray
(B-Line's Cable Channel)

Channel cable tray systems (B-Line's cable channel) are available in 3, 4, and 6 inch widths with ventilated or solid bottoms. **The NEC[®] now recognizes solid bottom cable channel.** Prior to the 2002 Code, the **NEC[®]** did not have any specific provisions for the use of solid cable channel.

Instead of large conduits, cable channel may be used very effectively to support cable drops from the cable tray run to the equipment or device being serviced and is ideal for cable tray runs involving a small number of cables. Cable channel may also be used to support push buttons, field mounted instrumentation devices, etc. Small diameter cables may exit ventilated cable channel through the bottom ventilation holes, out the top or through the end. For installations where the cables exit through the ventilation openings and the cable channel or the cables are subject to some degree of vibration, it is advisable to use B-Line Cable Channel Bushings (Cat. No. 99-1125). These snap-in plastic bushings provide additional abrasion protection for the cable jackets.

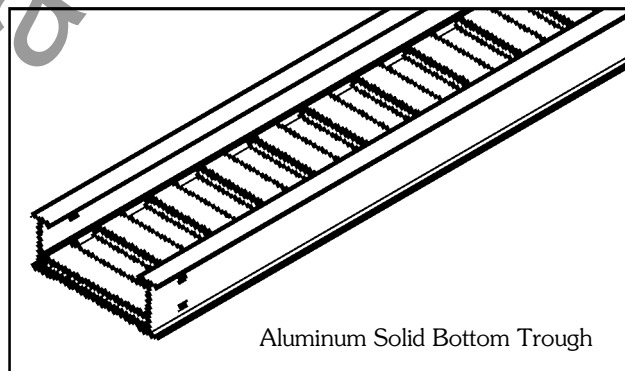

Aluminum Solid Bottom Trough

Some specifiers prefer solid bottom cable tray to support large numbers of small diameter control and multiconductor instrumentation cables. Solid bottom steel cable trays with solid covers and wrap around cover clamps can be used to provide EMI/RFI shielding protection for sensitive circuits.

Unlike ladder and ventilated trough cable trays, solid bottom cable trays can collect and retain moisture. Where they are installed outdoors or indoors in humid locations and EMI/RFI shielding protection is not required, it is recommended that 1/4 inch weep holes be drilled in their bottoms at the sides and in the middle every 3 feet to limit water accumulation.

The words "and other similar structures." were incorporated in Section 392.1 for future types of cable tray that might be developed, such as center supported type cable tray. All the technical information developed by the 1973 **NEC**[®] Technical Subcommittee on Cable Tray for Article 318 - Cable Trays was based on cable trays with side rails and this technical information is still the basis for the 2005 **NEC**[®] Article 392 - Cable Trays.

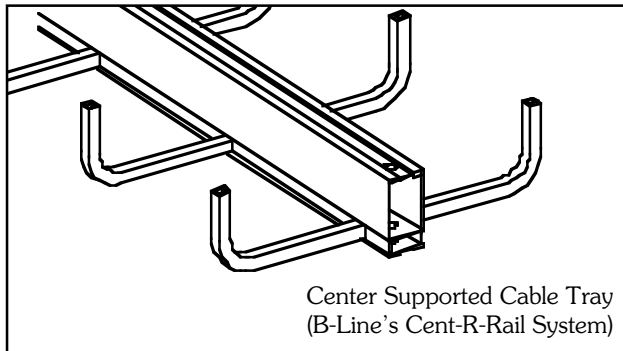

The standard lengths for cable trays are 10, 12, 20 and 24 feet (consult B-Line for the availability of nonstandard cable tray lengths). Selecting a cable tray length is based on several criteria. Some of these criteria include the required load that the cable tray must support, the distance between the cable tray supports, and ease of handling and installation. **One industry standard that is strongly recommended is that only one cable tray splice be placed between support spans** and, for long span trays, that they ideally be placed at 1/4-span. This automatically limits the length of tray you choose, as the tray must be longer than or equal to the support span you have selected. Matching the tray length to your support span can help ensure that your splice locations are controlled.

Cable trays can be organized into 4 categories: Short Span, Intermediate Span, Long Span, and Extra-Long Span.

Short Span trays, typically used for non-industrial indoor installations, are usually supported every 6 to 8 feet, while Intermediate Span trays are typically supported every 10 to 12 feet. A 10 or 12 foot cable tray is usually used for both of these types of installations. To keep from allowing two splices to occur between supports, a 12 foot tray should be used for any support span greater than 10 feet, up to 12 feet. Placing the cable tray splices at 1/4-span is not critical in a short or intermediate span application given that most trays have sufficiently strong splice plates.

In an indoor industrial installation 10 or 12 foot tray sections may be easier to handle and install as you may have piping or ducting to maneuver around. However, using 20 foot instead of 12 foot straight sections may provide labor savings during installation by reducing the number of splice joints. If this is done, the selected tray system should meet the loading requirements for the support span you are using. If you are interested in supporting 100 lbs/ft and you are buying 20 foot tray sections while supporting it every 12 feet, it isn't necessary to specify a NEMA 20C tray (100 lbs/ft on a 20 foot span). A NEMA 20A tray (50 lbs/ft on a 20 foot span) will support over 130 lbs/ft when supported on a 12 ft span with a safety factor of 1.5. Specifying a 20C tray is not an economical use of product. If you desire to use 20 foot sections of cable tray, it makes more sense to increase your support span up to 20 feet. This not only saves labor by decreasing the number of splices, but also by decreasing the number of supports that must be installed.

Long Span trays are typically supported anywhere from 14 to 20 foot intervals with 20 feet being the most popular. In long span situations, the placement of the splice locations at 1/4-span becomes much more important. Matching the tray length to your support span can help control your splice locations.

Extra-Long Span trays are supported on spans exceeding 20 feet. Some outdoor cable tray installations may have to span anywhere from 20 to 30 feet to cross roads or to reduce the number of expensive outdoor supports. The distance between supports affects the tray strength exponentially; therefore the strength of the cable tray system selected should be designed around the specific support span chosen for that run.

[See Section 392.5(A) on page 18 for additional information on cable tray strength and rigidity.]

B-Line has many cataloged fittings and accessory items for ladder, ventilated trough, ventilated channel, and solid bottom cable trays which eliminate the need for the costly field fabrication of such items. When properly selected and installed, these factory fabricated fittings and accessories improve the appearance of the cable tray system in addition to reducing labor costs.

Cable Tray Materials

Metallic cable trays are readily available in aluminum, pregalvanized steel, hot-dip galvanized after fabrication, and stainless steel. Aluminum cable tray should be used for most installations unless specific corrosion problems prohibit its use. Aluminum's light weight significantly reduces the cost of installation when compared to steel.

A fine print note is included in the 2005 **NEC**[®] that references the National Electrical Manufacturers Association (NEMA) documents for further information on cable tray. These documents: ANSI/NEMA VE-1, Metal Cable Tray Systems; NEMA VE-2, Cable Tray Installation Guidelines; and NEMA FG-1, Non Metallic Cable Tray Systems, are an excellent industry resource in the application, selection, and installation of cable trays both metallic and non metallic. Contact Cooper B-Line for more information concerning these helpful documents.

392.2. Definition. Cable Tray System.

This section states that cable tray is a rigid structural support system used to securely fasten or support cables and raceways. Cable trays are not raceways. Cable trays are mechanical supports just as strut systems are mechanical supports. **NEC**[®] Article 392 - Cable Trays is an article dedicated to a type of mechanical support. It is very important that the personnel involved with engineering and installing cable tray utilize it as a mechanical support system and not attempt to utilize it as a raceway system. There are items in the **NEC**[®] that apply to raceways and not to cable tray. There are also items in the **NEC**[®] that apply to cable tray and not to raceways. These differences will be covered at the appropriate locations in this manual.

392.3. Uses Permitted. Cable tray installations shall not be limited to industrial establishments.

The text in Section 392.3 clearly states that cable tray may be used in non-industrial establishments. The use of cable tray should be based on sound engineering and economic decisions.

For clarity, the **NEC**[®] now lists all types of circuits to explicitly permit their use in cable trays. These circuit types include: services, feeders, branch circuits, communication circuits, control circuits, and signaling circuits.

The 2002 **NEC**[®] also added a new requirement that where cables in tray are exposed to the direct rays of the sun, they shall be identified as sunlight resistant for all occupancies, not just industrial.

392.3. Uses Permitted. (A) Wiring Methods.

This section identifies the 300 & 600 volt multiconductor cables that may be supported by cable tray. The "Uses Permitted" or "Uses Not Permitted" sections in the appropriate **NEC**[®] cable articles provide the details as to where that cable type may be used. Where the cable type may be used, cable tray may be installed to support it except as per Section 392.4 which states that cable trays shall not be installed in hoistways or where subject to severe physical damage. Where not subject to severe physical damage, cable tray may be used in any hazardous (classified) area to support the appropriate cable types in accordance with the installation requirements of the various Articles that make up **NEC**[®] Chapter 5 or in any non-hazardous (unclassified) area.

It should be noted that Section 300.8 of the **NEC[®] states that cable trays containing electric conductors cannot contain any other service that is not electrical. This includes any pipe or tube containing steam, water, air, gas or drainage.**

For commercial and industrial cable tray wiring systems: Type ITC, Type MC, Type TC, and Type PLTC multiconductor cables are the most commonly used cables. Type MI and Optical-Fiber cables are special application cables that are desirable cables for use in some cable tray wiring systems. The following paragraphs provide information and comments about these cable types.

Type MI Cable: *Mineral-Insulated, Metal Sheathed Cable (Article 332).* This cable has a liquid and gas tight continuous copper sheath over its copper conductors and magnesium oxide insulation. Developed in the late 1920's by the French Navy for submarine electrical wiring systems, properly installed MI cable is the safest electrical wiring system available. In Europe, Type MI cable has had a long, successful history of being installed (with PVC jackets for corrosion protection) in cable trays as industrial wiring systems. This cable may be installed in hazardous (classified) areas or in non-hazardous (unclassified) areas. The single limitation

on the use of Type MI cable is that it may not be used where it is exposed to destructive corrosive conditions unless protected by materials suitable for the conditions. Type MI cable without overall nonmetallic coverings may be installed in ducts or plenums used for environmental air and in other space used for environmental air in accordance with Sections 300.22(B) and (C). Cable tray may be installed as a support for Type MI cable in any location except where the cable is installed in a hoistway. Section 332-30 states that MI cable shall be securely supported at intervals not exceeding 6 feet (1.83 m). Type MI cable has a UL two hour fire resistive rating when properly installed. An installation requirement for this rating is that the cable be securely supported every 3 feet. Steel or stainless steel cable trays should be used to support Type MI cable being used for critical circuit service. During severe fire conditions, steel or stainless steel cable tray will remain intact and provide support longer than aluminum or fiberglass reinforced plastic cable trays.

Type MC Cable: Metal-clad cable (Article 330). There are large amounts of Type MC cable installed in industrial plant cable tray systems. This cable is often used for feeder and branch circuit service and provides excellent service when it is properly installed. The metallic sheath may be interlocking metal tape or it may be a smooth or corrugated metal tube. A nonmetallic jacket is often extruded over the aluminum or steel sheath as a corrosion protection measure. Regular MC cable, without nonmetallic sheath, may be supported by cable tray in any hazardous (classified) area except Class I and Class II, Division 1 areas. For Type MC cables to qualify for installation in Class I and Class II Division I areas (Section 501-4(A) (1) (c&d)), they must have a gas/vapor tight continuous corrugated aluminum sheath with a suitable plastic jacket over the sheath. They must also contain equipment grounding conductors and listed termination fittings must be used where the cables enter equipment. Type MC Cable employing an impervious metal sheath without overall nonmetallic coverings may be installed in ducts or plenums used for environmental air in accordance with Section 300.22(B) and may be installed in other space used for environmental air in accordance with Section 300.22(C). The maximum support spacing is 6 feet (1.83 m).

Type TC Cable: Power and control tray cable (Article 336). This cable type was added to the

1975 **NEC**[®] (as an item associated with the revision of Article 318-Cable Trays). Type TC cable is a multiconductor cable with a flame retardant nonmetallic sheath that is used for power, lighting, control, and signal circuits. It is the most common cable type installed in cable tray for 480 volt feeders, 480 volt branch circuits, and control circuits. Where Type TC cables comply with the crush and impact requirements of Type MC cable and is identified for such use, they are permitted as open wiring between a cable tray and the utilization equipment or device. In these instances where the cable exits the tray, the cable must be supported and secured at intervals not exceeding 6 feet (See Section 336.10(6)). The service record of UL listed Type TC cable where properly applied and installed has been excellent.

For those installations where the **NEC**[®] allows its use, a cost savings is realized by using Type TC cables instead of Type MC cables. Type TC cable may be installed in cable tray in hazardous (classified) industrial plant areas as permitted in Articles 392, 501, 502, 504 and 505 provided the conditions of maintenance and supervision assure that only qualified persons will service the installation [See Section 336.10(3)].

Where a cable tray wiring system containing Type TC cables will be exposed to any significant amount of hot metal splatter from welding or the torch cutting of metal during construction or maintenance activities, temporary metal or plywood covers should be installed on the cable tray in the exposure areas to prevent cable jacket and conductor insulation damage. It is desirable to use only quality Type TC cables that will pass the IEEE 383 and UL Vertical Flame Tests (70,000 BTU/hr). Type TC cable assemblies may contain optical fiber members as per the UL 1277 standard.

Type ITC Cable: Instrumentation Tray Cable (Article 727). Although this was a new cable article in the 1996 **NEC**[®], it is not a new type of cable. Thousands of miles of ITC cable have been installed in industrial situations since the early 1960's. This is a multiconductor cable that most often has a nonmetallic jacket. The No. 22 through No. 12 insulated conductors in the cables are 300 volt rated. A metallic shield or a metallized foil shield with a drain wire usually encloses the cable's conductors. These cables are used to transmit the low energy level signals associated with the industrial

instrumentation and data handling systems. These are very critical circuits that impact on facility safety and on product quality. Type ITC cable must be supported and secured at intervals not exceeding 6 feet [See Section 727.4].

Type ITC Cable may be installed in cable trays in hazardous (classified) areas as permitted in Articles 392, 501, 502, 504 and 505. It states in Article 727 that Type ITC cables that comply with the crush and impact requirements of Type MC cable and are identified for such use, are permitted as open wiring in lengths not to exceed 50 ft. between a cable tray and the utilization equipment or device. Where a cable tray wiring system containing Type ITC cables will be exposed to any significant amount of hot metal splatter from welding or the torch cutting of metal during construction or maintenance activities, temporary metal or plywood covers should be installed on the cable tray to prevent cable jacket or conductor insulation damage. It is desirable to use only quality Type ITC cables that will pass the IEEE 383 and UL Vertical Flame Tests (70,000BTU/hr).

Type PLTC Cable: *Power-Limited Tray Cable (Sections 725-61(C), and 725-71(E))*. This is a multiconductor cable with a flame retardant nonmetallic sheath. The No. 22 through No. 12 insulated conductors in the cables are 300 volt rated. A metallic shield or a metallized foil shield with drain wire usually encloses the cable's conductors. This cable type has high usage in communication, data processing, fire protection, signaling, and industrial instrumentation wiring systems.

There are versions of this cable with insulation and jacket systems made of materials with low smoke emission and low flame spread properties which make them desirable for use in plenums. In Industrial Establishments where the conditions of maintenance and supervision ensure that only qualified persons service the installation and where the cable is not subject to physical damage Type PLTC cable may be installed in cable trays hazardous (classified) areas as permitted in Section 501.4(B), 502.4(B) and 504.20. Type PLTC cables that comply with the crush and impact requirements of Type MC cable and are identified for such use, are permitted as open wiring in lengths not to exceed a total of 50 ft. between a cable tray and the utilization equipment or device. In this situation, the cable needs to be supported and secured at intervals not exceeding 6 ft. Where a cable tray wiring system

containing Type PLTC cables will be exposed to any significant amount of hot metal splatter from welding or the torch cutting of metal during construction or maintenance activities, temporary metal or plywood covers should be installed on the cable tray to prevent cable jacket and conductor insulation damage. It is desirable to use only quality Type PLTC cables that will pass the IEEE 383 and UL Vertical Flame Tests (70,000 BTU/hr). Type PLTC cable assemblies may contain optical fiber members as per the UL 1277 standard.

Optical Fiber Cables (Article 770). The addition of optical fiber cables in the Section 392.3(A) cable list for the 1996 NEC was not a technical change. Optical fiber cables have been allowed to be supported in cable trays as per Section 770.6. Optical fibers may also be present in Type TC cables as per UL Standard 1277.

For the 1999 **NEC**[®] code, Article 760 - Fire Alarm Cables and Articles 800 - Multipurpose and Communications Cables were added to the list of cables permitted to be installed in cable tray systems.

For the 1993 **NEC**[®], the general statement in the 1990 **NEC**[®] which allowed all types of raceways to be supported by cable trays was replaced by individual statements for each of the ten specific raceway types that may now be supported by cable tray. The chances of any such installations being made are very low, since strut is a more convenient and economic choice than cable tray to support raceway systems.

392.3. Uses Permitted. (B) In Industrial Establishments.

This section limits the installation of single conductor cables and Type MV multiconductor cables in cable trays to qualifying industrial establishments as defined in this section.

Per the 2002 **NEC**[®] solid bottom cable trays are now permitted to support single conductor cables only in industrial establishments where conditions of maintenance and supervision ensure that only qualified persons will service the installed cable tray system. However, at this time, no fill rules for single conductor cables in solid bottom cable tray have been established. [see Section 392.3(B)]

392.3. Uses Permitted. (B) In Industrial Establishments. (1) Single Conductor.

Section 392.3(B)(1) covers 600 volt and Type MV single conductor cables.

There are several sections which cover the requirements for the use of single conductor cables in cable tray even though they only comprise a small percentage of cable tray wiring systems. Such installations are limited to qualifying industrial facilities [See Section 392.3(B)]. Many of the facility engineers prefer to use three conductor power cables. Normally, three conductor power cables provide more desirable electrical wiring systems than single conductor power cables in cable tray (See Section 392.8. Cable installation - three conductor vs. single conductor cables).

392.3(B)(1)(a)

Single conductor cable shall be No. 1/0 or larger and shall be of a type listed and marked on the surface for use in cable trays. Where Nos. 1/0 through 4/0 single conductor cables are used, the maximum allowable rung spacing for ladder cable tray is 9 inches.

392.3(B)(1)(b)

Welding cables shall comply with Article 630, Part IV which states that the cable tray must provide support at intervals not to exceed 6 inches. A permanent sign must be attached to the cable tray at intervals not to exceed 20 feet. The sign must read "CABLE TRAY FOR WELDING CABLES ONLY".

392.3(B)(1)(c)

This section states that single conductors used as equipment grounding conductors (EGCs) in cable trays shall be No. 4 or larger insulated, covered or bare.

The use of a single conductor in a cable tray as the EGC is an engineering design option. Section 300.3(B) states that all conductors of the same circuit and the EGC, if used, must be contained within the same cable tray.

The other options are to use multiconductor cables that each contain their own EGC or to use the cable tray itself as the EGC in qualifying installations [see Section 392.3(C)]

If an aluminum cable tray is installed in a moist environment where the moisture may contain materials that can serve as an electrolyte, a bare

copper EGC should not be used. Under such conditions, electrolytic corrosion of the aluminum may occur. For such installations, it is desirable to use a low cost 600 volt insulated conductor and remove the insulation where connections to equipment or to equipment grounding conductors are made. (See Section 392.7. Grounding, for additional information on single conductors used as the EGC for cable tray systems).

392.3. Uses Permitted. (B) In Industrial Establishment (2) Medium Voltage.

Single and multiconductor type MV cables must be sunlight resistant if exposed to direct sunlight. Single conductors shall be installed in accordance with 392.3(B)(1)

392.3. Uses Permitted. (C) Equipment Grounding Conductors.

Cable tray may be used as the EGC in any installation where qualified persons will service the installed cable tray system. There is no restriction as to where the cable tray system is installed. The metal in cable trays may be used as the EGC as per the limitations of table 392.7(B)(2). See Section 392.7. *Grounding* in this manual for additional information on the use of cable trays as the EGC.

392.3. Uses Permitted. (D) Hazardous (Classified) Locations.

This section states that if cable tray wiring systems are installed in hazardous (classified) areas, the cables that they support must be suitable for installation in those hazardous (classified) areas. The cable carries the installation restriction. The installation restriction is not on the cable tray except that the cable tray installations must comply with Section 392.4. The following is an explanation of the parts of the code which affect the use of cable tray in hazardous locations.

501.10. Wiring Methods - Listed Termination Fittings. (A) Class I, Division 1 (Gases or Vapors). 501.10(A)(1)(b) Type MI cable may be installed in cable tray in this type of hazardous (classified) area.

501.10(A)(1)(c) allows Type MC-HL cables to be installed in Class I, Division I areas if they have a gas/vapor tight continuous corrugated aluminum sheath with a suitable plastic jacket over the sheath. They must also contain equipment grounding conductors sized as per Section 250.122 and listed termination fittings must be used where the cables enter equipment.

501.10(A)(1)(d) allows Type ITC-HL cable to be installed in Class I, Division I areas if they have a gas/vapor tight continuous corrugated aluminum sheath with a suitable plastic jacket over the sheath and provided with termination fittings listed for the application.

501.10. Wiring Methods. (B) Class I, Division 2 (Gases or Vapors). Types ITC, PLTC, MI, MC, MV, or TC cables may be installed in cable tray in this type of hazardous (classified) area. Under the conditions specified in Section 501.15(E), Cable seals are required in Class 1, Division 2 areas. Cable seals should be used only when absolutely necessary.

501.15. Sealing and Drainage. (E) Cable Seals, Class 1, Division 2. (1) Cables will be required to be sealed only where they enter certain types of enclosures used in Class 1, Division 2 areas. Factory sealed push buttons are an example of enclosures that do not require a cable seal at the entrance of the cable into the enclosure.

501.15. Sealing and Drainage. (E) Cable Seals, Class 1, Division 2. (2) Gas blocked cables are available from some cable manufacturers but they have not been widely used. For gas to pass through the jacketed multiconductor cable's core, a pressure differential must be maintained from one end of the cable to the other end or to the point where there is a break in the cable's jacket. The existence of such a condition is extremely rare and would require that one end of the cable be in a pressure vessel or a pressurized enclosure and the other end be exposed to the atmosphere. The migration of any significant volume of gas or vapor through the core of a multiconductor cable is very remote. This is one of the safety advantages that cable tray wiring systems have over conduit wiring systems. There are documented cases of industrial explosions caused by the migration of gases and vapors through conduits when they came in contact with an ignition source. There are no known cases of cables in cable tray wiring systems providing a path for gases or vapors to an ignition source which produced an industrial explosion.

501.15. Sealing and Drainage. (E) Cable Seals, Class 1, Division 2. (3)

Exception: Cables with an unbroken gas/vapor-tight continuous sheath shall be permitted to pass through a Class 1, Division 2 location without seals.

This is an extremely important exception stating that cable seals are not required when a cable goes from an unclassified area through a classified area then back to an unclassified area.

501.15. Sealing and Drainage. (E) Cable Seals, Class 1, Division 2. (4)

If you do not have a gas/vapor-tight continuous sheath, cable seals are required at the boundary of the Division 2 and unclassified location.

The sheaths mentioned above may be fabricated of metal or a nonmetallic material.

502.10. Wiring Methods. (A) Class II, Division 1 (Combustible Dusts). Type MI cable may be installed in cable tray in this type of hazardous (classified) area.

The Exception allows Type MC cables to be installed in Class II, Division 1 areas if they have a gas/vapor tight continuous corrugated aluminum sheath with a suitable plastic jacket over the sheath. They must also contain equipment grounding conductors sized as per Section 250.122 and listed termination fittings must be used where the cables enter equipment.

502.10. Wiring Methods. (B) Class II, Division 2 (Combustible Dusts).

This section states:

Type ITC and PLTC cables may be installed in ladder or ventilated cable trays following the same practices as used in non-hazardous (unclassified) areas. No spacing is required between the ITC or PLTC cables. This is logical as the ITC and PLTC cable circuits are all low energy circuits which do not produce any significant heat or heat dissipation problems.

Type MC, MI and TC [See Section 336.4(3)] cables may be installed in ladder, ventilated trough, or ventilated cable channel, but they are not allowed to

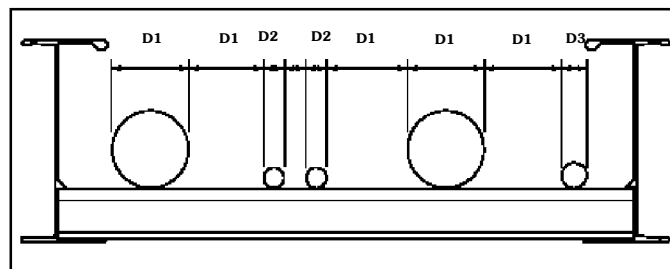

be installed in solid bottom cable trays.

Required Spacing in Cable Trays for Type MC, MI & TC Cables in Class II, Division 2 Hazardous (Classified) Areas

Note 1. The cables are limited to a single layer with spacing between cables equal to the diameter of the largest adjacent cable. This means that the cables must be tied down at frequent intervals in horizontal as well as vertical cable trays to maintain the cable spacing. A reasonable distance between ties in the horizontal cable tray would be approximately 6 feet (See Section 392.8 Cable Installation - Tying cables to cable trays).

Note 2. Spacing the cables a minimum of 1 inch from the side rails to prevent dust buildup is recommended. This is not an NEC requirement but a recommended practice.

Where cable tray wiring systems with current carrying conductors are installed in a dust environment, ladder type cable trays should be used since there is less surface area for dust buildup than in ventilated trough cable trays. The spacing of the cables in dust areas will prevent the cables from being totally covered with a solid dust layer. In dusty areas, the top surfaces of all equipment, raceways, supports, or cable jacket surfaces where dust layers can accumulate will require cleanup housekeeping at certain time intervals. Good housekeeping is required for personnel health, personnel safety and facility safety. Excessive amounts of dust on raceways or cables will act as a thermal barrier which may not allow the power and lighting insulated conductors in a raceway or cable to safely dissipate internal heat. This condition may result in the accelerated aging of the conductor insulation. A cable tray system that is properly installed and maintained will provide a safe dependable wiring system in dust environments.

Exception: Type MC cable listed for use in Class II, Division I locations shall be permitted to be installed without the above spacing limitations. This was a new exception for the 1999 NEC® code.

For this type of wiring there is no danger of the cables being overheated when covered with dust. The current flow in these circuits is so low that the internally generated heat is insufficient to heat the cables and cable spacing is not a necessity. Even under such conditions, layers of dust should not be allowed to accumulate to critical depths as they may be ignited or explode as the result of problems caused by other than the electrical system.

502.10(B)(3). Nonincendive Field Wiring

Wiring in nonincendive circuits shall be permitted using any of the wiring methods suitable for wiring

in ordinary locations.

503.10. Wiring Methods. (A) Class III, Division 1 and (B) Class III, Division 2 (Ignitable Fibers or Flyings). Type MI or MC cables may be installed in cable tray in these types of hazardous (classified) areas. The installations should be made using practices that minimize the build-up of materials in the trays. This can be done by using ladder cable tray with a minimum spacing between the cables equal to the diameter of the largest adjacent cable. In some cases, a greater spacing between cables than that based on the cable diameters might be desirable depending on the characteristics of the material that requires the area to be classified. Here again, it must be emphasized that good housekeeping practices are required for all types of wiring systems to insure the safety of the personnel and the facility.

504.20. Wiring Methods. This section allows intrinsically safe wiring systems to be installed in cable trays in hazardous (classified) areas. Section 504.30 specifies the installation requirements for intrinsically safe wiring systems that are installed in cable trays. Section 504.70 specifies the sealing requirements for cables that may be part of a cable tray wiring system. Section 504.80(B) states that cable trays containing intrinsically safe wiring must be identified with permanently affixed labels.

Cable trays are ideal for supporting both intrinsically safe and nonintrinsically safe cable systems as the cables may be easily spaced and tied in position or a standard metallic barrier strip may be installed between the intrinsically and nonintrinsically safe circuits.

505.15. Wiring Methods. This section was added to the 2002 NEC® to explicitly permit cable trays in hazardous areas classified by the international zone system, if the cables comply with the cable requirements for zone locations.

392.3. Uses Permitted. (E) Nonmetallic Cable Tray.

There are limited numbers of applications where nonmetallic cable trays might be preferred over metallic cable trays for electrical safety reasons and/or for some corrosive conditions. An example of an electrical safety application would be in an electrolytic cell room. Here, the amperages are very high and significant stray current paths are present. Under such conditions, there is the possibility for a

high amperage short circuit if a low resistance metallic path (metallic cable tray or metallic raceway) is present [See information under Section 392.5(F) Nonmetallic Cable Trays].

392.4. Uses Not Permitted.

This is the only place in the NEC® where all the various types of cable tray have limitations on their place of use. No cable trays can be used in hoistways or where subject to severe physical damage. The designer must identify the zones of installation where a cable tray might be subjected to severe physical damage. Usually such areas are limited and provisions can be made to protect the cable tray by relocating it to a more desirable location or as a last resort to provide protection using the appropriate structural members.

The second sentence of Section 392.4 states that cable tray shall not be used in ducts, plenums, and other air-handling spaces except to support the wiring methods recognized for use in such spaces. This is not a restriction on cable tray as long as it is used as a support for the appropriate cable types.

Metallic cable trays may support cable types approved for installation in ducts, plenums, and other air-handling spaces as per Section 300.22(B) and the cable types approved for installation in Other Space Used for Environmental Air as per Section 300.22(C).

The second sentence of Section 300.22(C)(1) is as follows:

Other types of cables and conductors shall be installed in electrical metallic tubing, flexible metallic tubing, intermediate metal conduit, rigid metal conduit without an overall nonmetallic covering, flexible metal conduit, or, where accessible, surface metal raceway or metal wireway with metal covers or solid bottom metal cable tray with solid metal covers.

Reprinted with permission from NFPA 70-1999, the National Electrical Code®, Copyright© 1998, National Fire Protection Association, Quincy, MA 02269. This reprinted material is not the complete and official position of the National Fire Protection Association, on the referenced subject which is represented only by the standard in its entirety.

This part of Section 300.22(C) is confusing. The statement as underlined in the above paragraph leads some to assume, for installations in Other Spaces Used for Environmental Air, that the types of insulated single conductors which are installed in raceway installations may also be installed in solid bottom metal cable trays with metal covers. This is

not so. Only the appropriate multiconductor cable types as per Section 392.3(A) may be installed in solid bottom cable trays.

Cable tray may be used to support data process wiring systems in air handling areas below raised floors as per Sections 300.22(D) and 800.52(D).

392.5. Construction Specifications. (A) Strength and Rigidity.

The designer must properly select a structurally satisfactory cable tray for their installation. This selection is based on the cable tray's strength, the cable tray loading and the spacing of the supports. The ANSI/NEMA Metallic Cable Tray Systems Standard Publication VE-1 contains the cable tray selection information and it is duplicated in B-Line's Cable Tray Systems Catalog.

The NEMA Standard provides for a static load safety factor of 1.5. A number (Span in Feet - the distance between supports) and letter (Load in lbs/ft) designation is used to properly identify the cable tray class on drawings, in specifications, in quotation requisitions, and in purchase requisitions to guarantee that the cable tray with the proper characteristics will be received and installed. The designer must specify the cable tray type, the material of construction, section lengths, minimum bend radius, width, rung spacing (for a ladder type cable tray), and the total loading per foot for the cables on a maximum support spacing (See page 52 for cable tray specifications checklist). For many installations, the cable trays must be selected so that they are capable of supporting specific concentrated loads, the weight of any equipment or materials attached to the cable tray, ice and snow loading,



and for some installations the impact of wind loading and/or earthquakes must be considered.

Most cable trays are utilized as continuous beams with distributed and concentrated loads. Cable trays can be subjected to static loads like cable loads and dynamic loads such as wind, snow, ice, and even earthquakes. The total normal and abnormal loading

for the cable tray is determined by adding all the applicable component loads. The cable load + the concentrated static loads + ice load (if applicable) + snow load (if applicable) + wind load (if applicable) + any other logical special condition loads that might exist. This total load is used in the selection of the cable tray.

The following is an explanation of the 'historical' NEMA cable tray load classifications found in ANSI/NEMA VE-1.

There used to be four cable tray support span categories, 8, 12, 16, and 20 feet, which are coupled with one of three load designations, "A" for 50 lbs/ft, "B" for 75 lbs/ft, and "C" for 100 lbs/ft. For example, a NEMA class designation of 20B identifies a cable tray that is to be supported at a maximum of every 20 feet and can support a static load of up to 75 lbs/linear foot.

The cable load per foot is easy to calculate using the cable manufacturer's literature. If the cable tray has space available for future cable additions, a cable tray has to be specified that is capable of supporting the final future load. Although these historical load designations are still useful in narrowing down the choices of cable trays, NEMA has recently changed the VE-1 document. ANSI/NEMA VE-1 now requires the marking on the cable trays to indicate the exact rated load on a particular span. Trays are no longer limited to the four spans and three loads listed above. Now, for example, a tray may be rated for 150 lbs/ft on a 30 ft. span. It is recommended when specifying cable tray, to specify the required load, support span and straight section length to best match the installation.

Example of Cable Loading per foot:

- 10 - 3/C No. 4/0 (2.62 lbs/ft)
Total = 26.20 lbs/ft
- 3 - 3/C No. 250 kcmil (3.18 lbs/ft)
Total = 9.54 lbs/ft
- 4 - 3/C No. 500 kcmil (5.87 lbs/ft)
Total = 23.48 lbs/ft

Total Weight of the Cables = **59.22 lbs/ft**

These cables would fill a 30 inch wide cable tray and if a 36 inch wide cable tray were used there would be space available for future cables (See pages 47 thru 53 for information on calculating tray width.). To calculate the proper cable tray design load for the 36" wide cable tray multiply 59.22 lbs/ft x 36 inches/30 inches = 71.06 lbs/ft. If this cable tray is

installed indoors, a load symbol "B" cable tray would be adequate. If there were additional loads on the cable tray or the cable tray were installed outdoors, it would be necessary to calculate all the additional potential loads. The potential load most often ignored is installation loads. The stresses of pulling large cables through cable trays can produce 3 times the stress of the cables' static load. If the installation load is not evaluated the cable tray may be damaged during installation. A 16C or 20C NEMA Class should be specified if large cables are to be pulled.

Even though walking on cable tray is not recommended by cable tray manufacturers and OSHA regulations, many designers will want to specify a cable tray which can support a 200 lb. concentrated load "just in case". A concentrated static load applied at the midspan of a cable tray is one of the most stressful conditions a cable tray will experience. To convert a static concentrated load at midspan to an equivalent distributed load take twice the concentrated load and divide it by the support span [(2 x 200 lbs.)/Span]. The strength of the rung is also a very important consideration when specifying a concentrated load. The rung must be able to withstand the load for any tray width, as well as additional stresses from cable installation. Excessive rung deflection can weaken the entire cable tray system. B-Line uses heavier rungs on their wider industrial trays as a standard. Most cable tray manufacturer's rungs are not heavy enough to withstand concentrated loads at 36" tray widths.

For outdoor installations a cable tray might be subject to ice, snow, and wind loading. Section 25 of the National Electrical Safety Code (published by the Institute of Electrical and Electronic Engineers) contains a weather loading map of the United States to determine whether the installation is in a light, medium, or heavy weather load district. NESC Table 250-1 indicates potential ice thicknesses in each loading district as follows: 0.50 inches for a heavy loading district, 0.25 inches for a medium loading district, and no ice for a light loading district. To calculate the ice load use 57 pounds per cubic foot for the density of glaze ice. Since tray cables are circular and the cable tray has an irregular surface the resulting ice load on a cable tray can be 1.5 to 2.0 times greater than the glaze ice load on a flat surface.

Snow load is significant for a cable tray that is completely full of cables or a cable tray that has covers. The density of snow varies greatly due to its

moisture content, however the minimum density that should be used for snow is 5 pounds per cubic foot. The engineer will have to contact the weather service to determine the potential snow falls for the installation area or consult the local building code for a recommended design load.

Usually cable trays are installed within structures such that the structure and equipment shelter the cable trays from the direct impact of high winds. If wind loading is a potential problem, a structural engineer and/or the potential cable tray manufacturer should review the installation for adequacy. To determine the wind speed for proper design consult the Basic Wind Speed Map of the United States in the NESC (Figure 250-2).

For those installations located in earthquake areas, design engineers can obtain behavioral data for B-Line cable trays under horizontal, vertical and longitudinal loading conditions. Testing done for nuclear power plants in the 1970's indicates that cable trays act like large trusses when loaded laterally and are actually stronger than when loaded vertically. Cable tray supports may still need to be seismically braced and designers should consult the B-Line Seismic Restraints Catalog for detailed design information.

The midspan deflection multipliers for all B-Line cable trays are listed in the Cable Tray Systems catalog. Simply pick your support span and multiply your actual load by the deflection multiplier shown for that span. The calculated deflections are for simple beam installations at your specified load capacity. If a deflection requirement will be specified, extra care needs to be taken to ensure that it does not conflict with the load requirement and provides the aesthetics necessary. Keep in mind that continuous beam applications are more common and will decrease the deflection values shown by up to 50%. Also, aluminum cable trays will deflect 3 times more than steel cable trays of the same NEMA class.

To complete the design, the standard straight section length and minimum bend radius must be chosen. When selecting the recommended length of straight sections, be sure that the standard length is greater than or equal to the maximum support span. Choose a fitting radius which will not only meet or exceed the minimum bend radius of the cables but will facilitate cable installation.

[See page 11 for more information on selecting the appropriate cable tray length]

392.5. Construction Specifications. (B) Smooth Edges.

This is a quality statement for cable tray systems and their construction. B-Line cable tray is designed and manufactured to the highest standards to provide easy, safe installation of both the cable tray and cables.

392.5. Construction Specifications. (C) Corrosion Protection.

Cable tray shall be protected from corrosion per Section 300.6, which lists some minimum criteria for different corrosive environments. The B-Line Cable Tray Catalog contains a corrosion chart for cable tray materials. Cable trays may be obtained in a wide range of materials including aluminum, pregalvanized steel, hot dipped galvanized steel (after fabrication), Type 304 or 316 stainless steel, polyvinyl chloride (PVC) or epoxy coated aluminum or steel and also nonmetallic (fiber reinforced plastic). Check with a metallurgist to determine which metals and coatings are compatible with a particular corrosive environment. B-Line has corrosion information available and may be able to recommend a suitable material. Remember that no material is totally impervious to corrosion. Stainless steel can deteriorate when attacked by certain chemicals and nonmetallic cable trays can deteriorate when attacked by certain solvents.

392.5. Construction Specifications. (D) Side Rails.

The technical information in Article 392 was originally developed for cable trays with rigid side rails by the 1973 **NEC**[®] Technical Subcommittee on Cable Tray. "Equivalent Structural Members" was added later to incorporate new styles of cable tray such as center rail type tray and 'mesh' or wire basket tray.

392.5. Construction Specifications. (E) Fittings.

This section has been misinterpreted to mean that cable tray fittings must be used for all changes in direction and elevation [See Section 392.6(A) Complete system for further explanation). When two cable tray runs cross at different elevations, lacing a cable between the rungs of one tray and dropping into the other is a common practice which changes the direction of the cable while providing adequate cable

support. Although the use of cable tray fittings is not mandatory, it is often desirable to use them when possible to improve the appearance of the installation.

392.5. Construction Specifications. (F) Nonmetallic Cable Tray.

This type of cable tray is usually made of Fiberglass Reinforced Plastic (FRP). Applications for FRP cable tray systems include some corrosive atmospheres and where non-conductive material is required. B-Line fiberglass cable tray systems are manufactured from glass fiber reinforced plastic shapes that meet ASTM flammability and self-extinguishing requirements. A surface veil is applied during pultrusion to ensure a resin rich surface and increase ultraviolet resistance, however, for extended exposure to direct sunlight, additional measures, such as painting the tray, are sometimes employed

to insure the longevity of the product. Ambient temperature is also a design consideration when FRP cable tray is used. An ambient temperature of 100°F will decrease the loading capacity of polyester resin fiberglass cable tray by 10%.

392.6. Installation. (A) Complete System.

This section states that cable tray systems can have mechanically discontinuous segments, and that the mechanically discontinuous segment cannot be greater than 6 feet. A bonding jumper sized per Section 250.102 is necessary to connect across any discontinuous segment. The bonding of the system should be in compliance with Section 250.96.

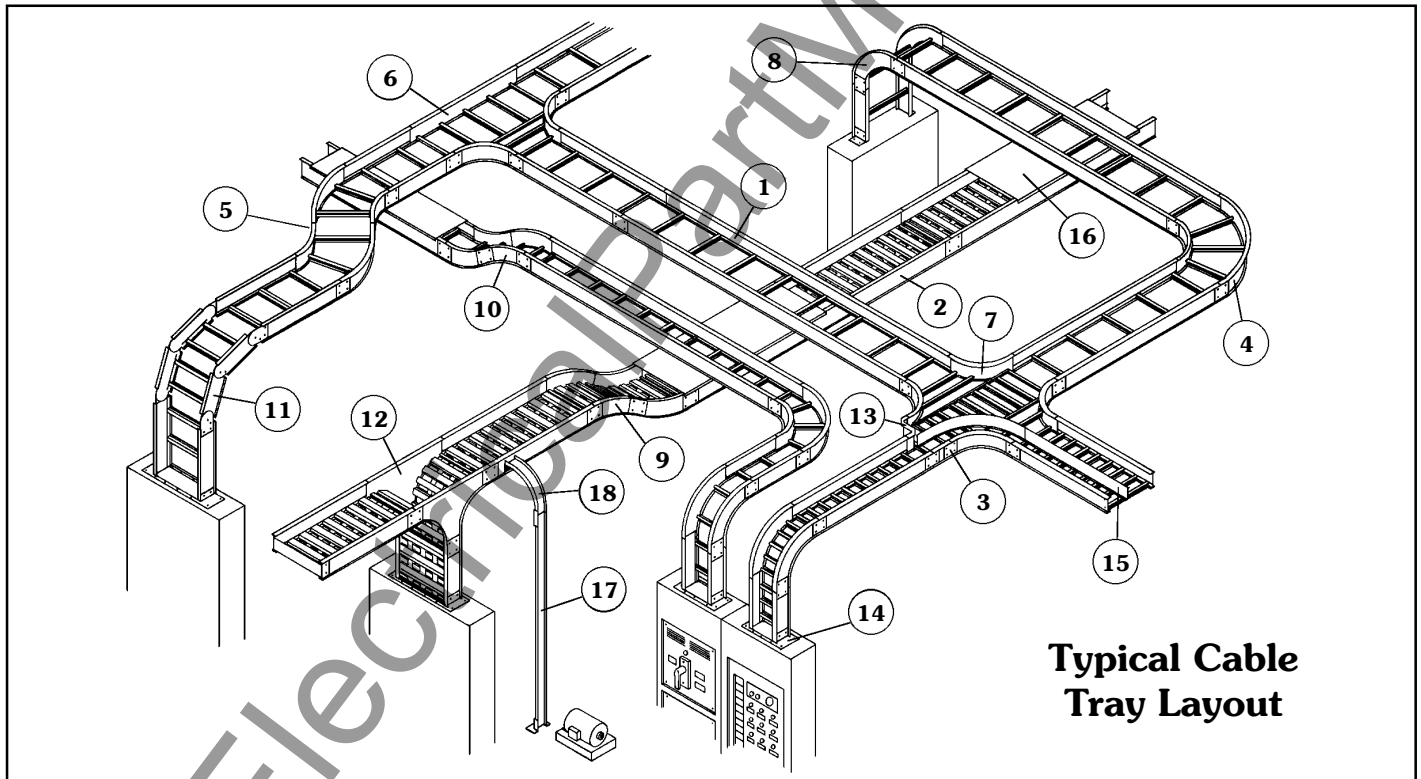
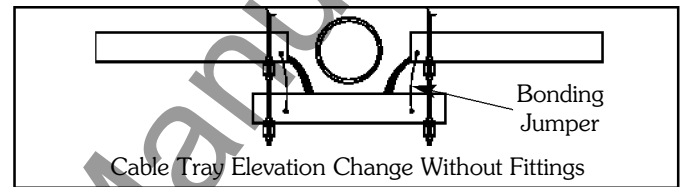

Nomenclature

- | | |
|--|--|
| 1. Ladder Type Cable Tray | 10. 30° Vertical Inside Bend, Ladder Type Tray |
| 2. Ventilated Trough Type Cable Tray | 11. Vertical Bend Segment (VBS) |
| 3. Splice Plate | 12. Vertical Tee Down, Ventilated Trough Type Tray |
| 4. 90° Horizontal Bend, Ladder Type Tray | 13. Left Hand Reducer, Ladder Type Tray |
| 5. 45° Horizontal Bend, Ladder Type Tray | 14. Frame Type Box Connector |
| 6. Horizontal Tee, Ladder Type Tray | 15. Barrier Strip Straight Section |
| 7. Horizontal Cross, Ladder Type Tray | 16. Solid Flanged Tray Cover |
| 8. 90° Vertical Outside Bend, Ladder Type Tray | 17. Cable Channel Straight Section, Ventilated |
| 9. 45° Vertical Outside Bend, Ventilated Type Tray | 18. Cable Channel, 90° Vertical Outside Bend |

There are some designers, engineers, and inspectors that do not think that cable tray is a mechanical support system just as strut is a mechanical support system. Cable tray is not a raceway in the **NEC**[®] but some designers, engineers, and inspectors attempt to apply the requirements for raceway wiring systems to cable tray wiring systems even when they are not applicable. Cable tray wiring systems have been used by American industry for over 35 years with outstanding safety and continuity of service records. The safety service record of cable tray wiring systems in industrial facilities has been significantly better than those of conduit wiring systems. There have been industrial fires and explosions that have occurred as a direct result of the wiring system being a conduit wiring system. In these cases, cable tray wiring systems would not have provided the fires and explosions that the conduit systems did by providing an explosion gas flow path to the ignition source even though the conduit systems contained seals.

The most significant part of this section is that the metallic cable tray system must have electrical continuity over its entire length and that the support for the cables must be maintained. These requirements can be adequately met even though there will be installation conditions where the cable tray is mechanically discontinuous, such as at a fire wall penetration, at an expansion gap in a long straight cable tray run, where there is a change in elevation of a few feet between two horizontal cable tray sections of the same run, or where the cables drop from an overhead cable tray to enter equipment. In all these cases, adequate bonding jumpers must be used to bridge the mechanical discontinuity.

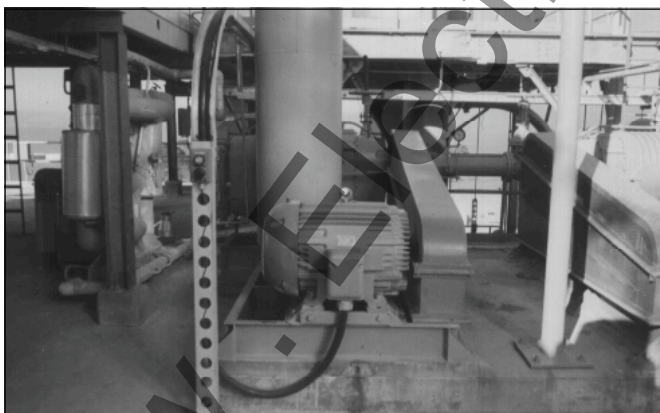

Control Cable Entering Pushbutton and Power Cable Entering Motor Terminal Box from 6 Inch Channel Cable Tray System
(Bottom entries provide drip loops to prevent moisture flow into enclosures.)

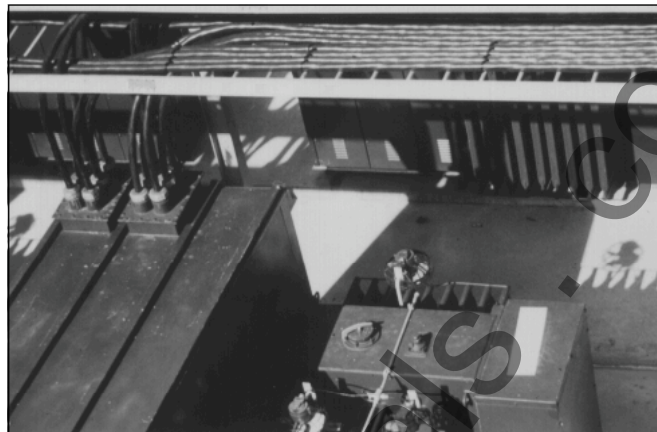

Cables Exiting 480 Volt Outdoor Switchgear and Entering Cable Tray System
(Cable fittings with clamping glands are required to prevent moisture flow into equipment due to the cable's overhead entry into the switchgear enclosure).



Cables Entering and Exiting Motor Control Centers from Cable Tray Systems.

392.6. Installation. (B) Completed Before Installation.

This means that the final cable tray system must be in place before the cables are installed. It does not mean that the cable tray must be 100% mechanically continuous. The electrical bonding of the metallic cable tray system must be complete before any of the circuits in the cable tray system are energized whether the cable tray system is being utilized as the equipment grounding conductor in qualifying installations or if the bonding is being done to satisfy the requirements of Section 250.96.

392.6. Installation. (C) Supports.

The intent of this section is to ensure that the conductor insulation and cable jackets will not be damaged due to stress caused by improper support. Multiconductor 600 volt Type TC cables and 300 volt Type PLTC cables exhibit a high degree of damage resistance when exposed to mechanical abuse at normal temperatures.

During an inspection of industrial installations by the 1973 **NEC**[®] Technical Subcommittee on Cable Tray, a test setup was constructed of an 18 inch wide Class 20C aluminum cable tray supported three feet above ground level containing several sizes of multiconductor cables. This installation was continuously struck in the same area with eight pound sledge hammers until the cable tray was severely distorted, the cables however, exhibited only cosmetic damage. When these cables were tested electrically, they checked out as new tray cable. Since that time, significant improvements have been made in cable jacket and conductor insulation materials so that the cables available today are of better quality than the 1973 test cables. Although tray cables are capable of taking a great deal of abuse without any problems, cable tray installations must be designed by taking appropriate measures to ensure that the tray cables will not be subjected to mechanical damage.

392.6. Installation. (D) Covers.

Cable tray covers provide protection for cables where cable trays are subject to mechanical damage. The most serious hazard to cable in cable trays is when the cables are exposed to significant amounts of hot metal spatter during construction or maintenance from torch cutting of metal and welding activities. For these exposure areas, the cable tray should be temporarily covered with plywood sheets. If such exposure is to be a frequent occurrence, cable tray covers should be installed in the potential exposure areas. Where cable trays contain power and lighting conductors, raised or ventilated covers are preferable to solid covers since the raised or ventilated covers allow the cable heat to be vented from the cable tray.

When covers are installed outdoors, they should be attached to the cable trays with heavy duty wrap around clamps instead of standard duty clips. During

high winds, the light duty clips are not capable of restraining the covers. Outdoor cover installations should be overlapped at expansion joint locations to eliminate cover buckling. Covers which fly off the cable tray create a serious hazard to personnel, as was the case at a Texas gulf coast chemical plant where operators would not leave their control room because hurricane force winds had stripped many light gauge stainless steel covers off a large cable tray system. These sharp edged metal covers were flying through the air all during the high wind period, posing a serious threat to the worker's safety.

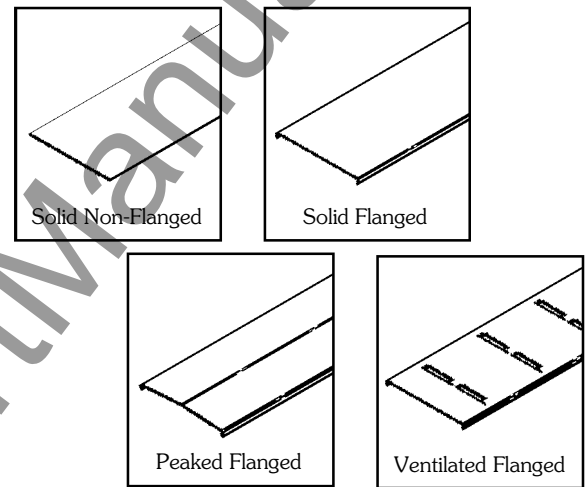

Types of Cable Tray Covers.

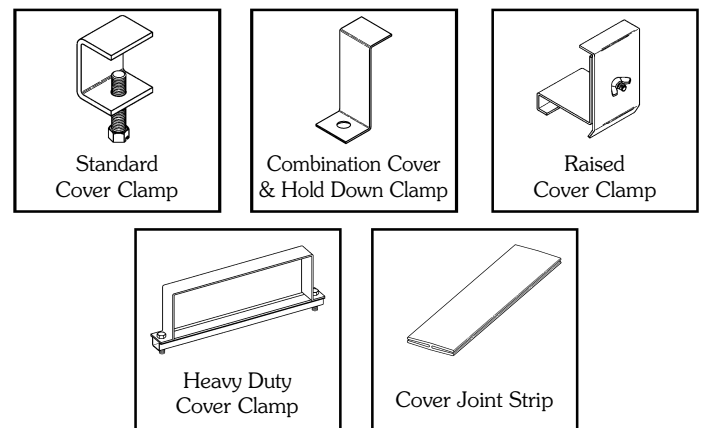

Aluminum Cable Tray Cover Accessories -
Equivalent Items are available for Steel Cable Trays.

392.6. Installation. (E) Multiconductor Cables Rated 600 Volts or Less.

Cables containing 300 or 600 volt insulated conductors may be installed intermingled in the same cable tray which is different from the requirements for raceways. This is a reasonable arrangement because a person may safely touch a 300 or 600 volt cable which is in good condition, so having the cables come into contact with each other is not a problem either. Many cable tray users separate the instrumentation cables from the power and control cables by installing them in separate cable trays or by installing barriers in the cable trays. Often, because of the volume of the instrumentation cable, using separate cable trays is the most desirable installation practice.

Numerous cable tray systems have been installed where the instrumentation cables and branch circuit cables are installed in the same cable trays with and without barriers with excellent performance and reliability. Most problems that occur involving instrumentation circuits are due to improper grounding practices. For analog and digital instrumentation circuits, good quality twisted pair Type ITC and Type PLTC cables with a cable shield and a shield drain wire should be used. Do not purchase this type of cable on price alone, it should be purchased because of its high quality. Engineers specifying cables should be knowledgeable of the cable's technical details in order to design systems which will provide trouble free operation.

392.6. Installation. (F) Cables Over 600 Volts.

Cables with insulation rated 600 volts or less may be installed with cables rated over 600 volts if either of the following provisions are met.

No. 1: Where the cables over 600 volts are Type MC.

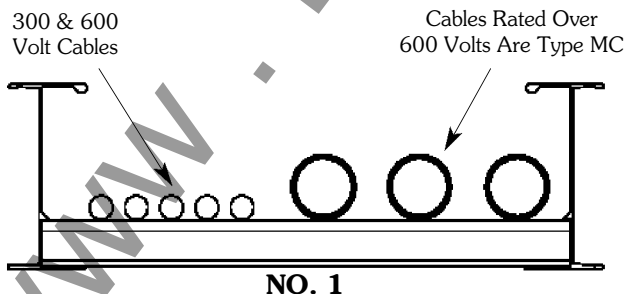

No. 2: Where separated with a fixed solid barrier of a material compatible with the cable tray.

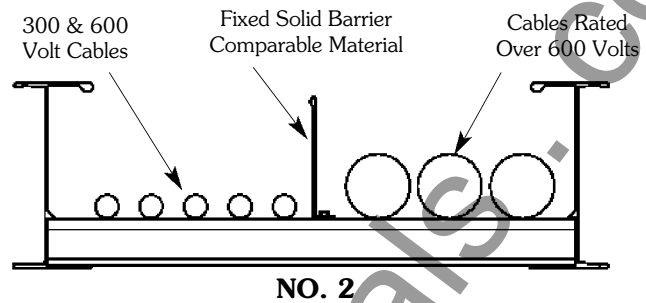

392.6. Installation. (G) Through Partitions and Walls.

Whether penetrating fire rated walls with tray cable only or cable tray and tray cable, the designer should review with the local building inspector the method he proposes to use to maintain the fire rating integrity of the wall at the penetration. Many methods for sealing fire wall penetrations are available, including bag or pillow, caulk, cementitious, foam, putty and mechanical barrier systems.

Many designers prefer to run only the tray cable through fire rated walls. Sealing around the cables is easier than sealing around the cables and the cable tray. Also, should the cable tray or its supports become damaged, the tray will not exert forces which could damage the wall or the penetration.

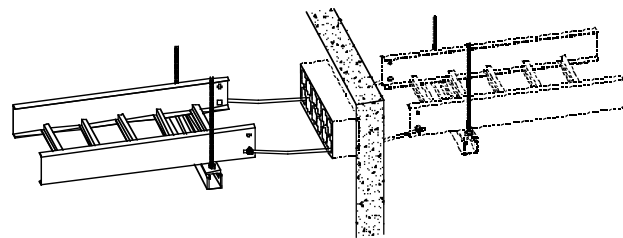

392.6. Installation. (H) Exposed and Accessible.

Article 100 - Definitions.

Exposed: (as applied to wiring methods) on or attached to the surface or behind panels designed to allow access.

Accessible: (As applied to wiring methods) Capable of being removed or exposed without damaging the building structure or finish, or not permanently closed in by the structure or finish of the building.

Reprinted with permission from NFPA 70-1999, the National Electrical Code®, Copyright© 1998, National Fire Protection Association, Quincy, MA 02269. This reprinted material is not the complete and official position of the National Fire Protection Association, on the referenced subject which is represented only by the standard in its entirety.

392.6. Installation. (I) Adequate Access.

Cable tray wiring systems should be designed and installed with adequate room around the cable tray to allow for the set up of cable pulling equipment. Also, space around the cable tray provides easy access for installation of additional cables or the removal of surplus cables. Where cable trays are mounted one above the other, a good rule to follow is to allow 12 to 18 inches between the underside and the top of adjacent cable trays or between the structure's ceiling and the top of the cable tray.

392.6. Installation. (J) Conduits and Cables Supported from Cable Tray.

For the 1996 **NEC**®, a significant change was made in this section. The installations covered in this section may now only be made in qualifying industrial facilities.

In Section 392.6(J) of the 1993 **NEC**®, cable tray installations that supplied support for conduits were not restricted to qualifying industrial facilities. The 1996 **NEC**®, Section 392.6(J) text restricts the use of such installations even though there is no documented history of problems in non-industrial installations.

As a result of the change in this section, identical functional installations in non-qualifying installations (commercial and industrial) and qualifying industrial installations have different physical requirements. In a qualifying industrial installation, a conduit terminated on a cable tray may be supported from the cable tray. In a commercial or non-qualifying industrial installation, the conduit that is terminated on the cable tray must be securely fastened to a support that is within 3 feet of the cable tray or securely fastened to a support that is within 5 feet of the cable tray where structural members don't readily permit a secure fastening within 3 feet. The

conduit of the non-qualifying installation still needs to be bonded to the cable tray. A fitting may be used for this bonding even though it will not count as a mechanical support.

Over 99 percent of the conduits supported on cable trays are the result of conduits being terminated on the cable tray side rails [See Section 392.8(C)]. For over 40 years, it has been common practice to house the cables exiting the cable tray in conduits or cable channel where the distance from the cable tray system to the cable terminations requires the cable be supported. Several manufacturers supply UL approved cable tray to conduit clamps such as the B-Line 9ZN-1158.

In addition to conduit and cables being supported from cable tray; industrial companies have been mounting instrumentation devices, push buttons, etc. on cable tray and cable channel for over 40 years. This section once lead some to believe that only conduit or cables may be supported from cable trays which is not correct as cable tray is a mechanical support just as strut is a mechanical support. Because of this, the wording in Section 392.6(J) of the 2002 **NEC**® was changed. Instead of allowing only cable and conduit to be supported from cable tray, the code now states that **raceways, cables, boxes and conduit bodies** are now permitted to be supported from the cable tray. Where boxes or conduit bodies are attached to the bottom or side of the cable tray, they must be fastened and supported in accordance with Section 314.23.

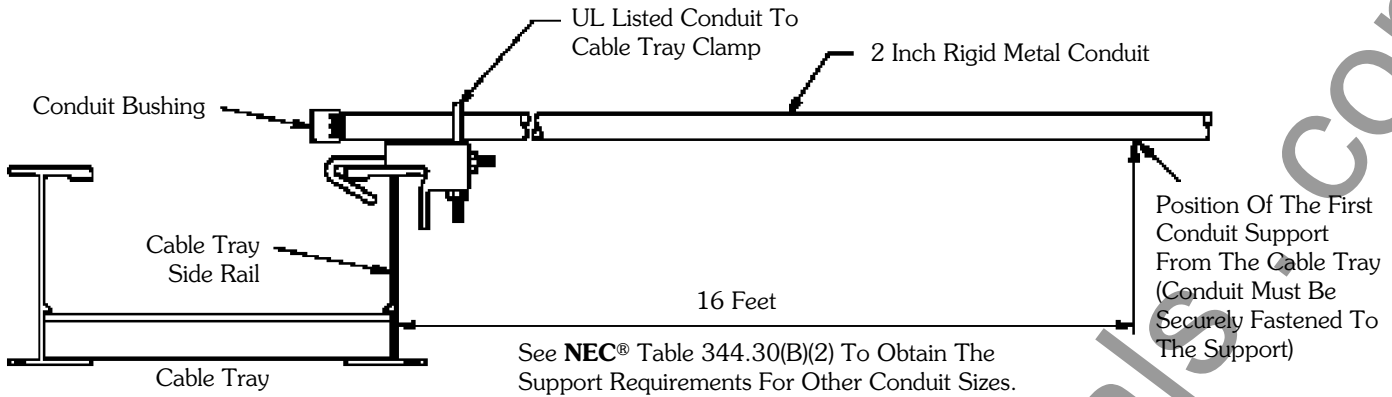

**Conduit Terminated On And Supported By The Cable Tray Side Rail.
Installation For Qualifying Industrial Facilities As Per 392.6(J).**

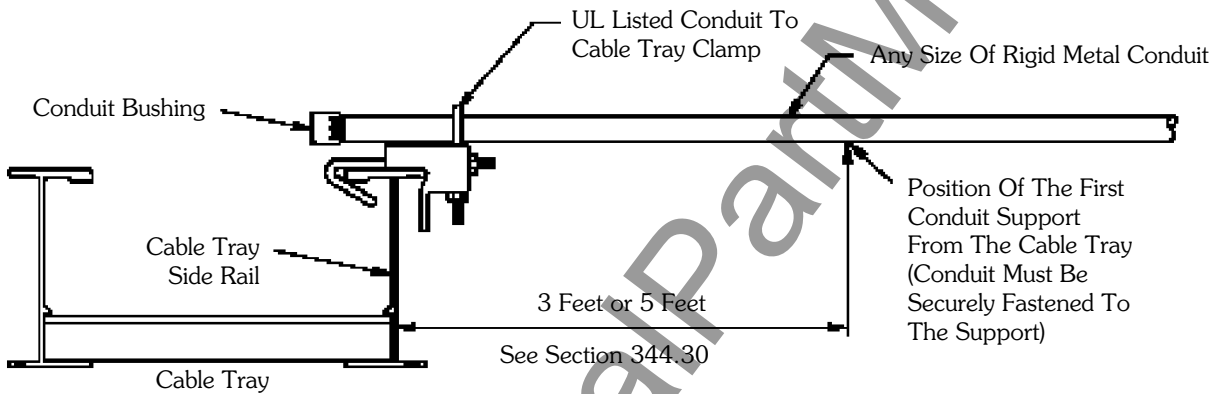

**Conduit Terminated On The Cable Tray Side Rail.
Installation For Commercial And Non-Qualifying Industrial Facilities As Per 392.6(J).**

392.7. Grounding. (A) Metallic Cable Trays.

All metallic cable trays shall be grounded as required in Article 250.96 regardless of whether or not the cable tray is being used as an equipment grounding conductor (EGC).

The EGC is the most important conductor in an electrical system as its function is electrical safety.

There are three wiring options for providing an EGC in a cable tray wiring system: (1) An EGC conductor in or on the cable tray. (2) Each multiconductor cable with its individual EGC conductor. (3) The cable tray itself is used as the EGC in qualifying facilities.

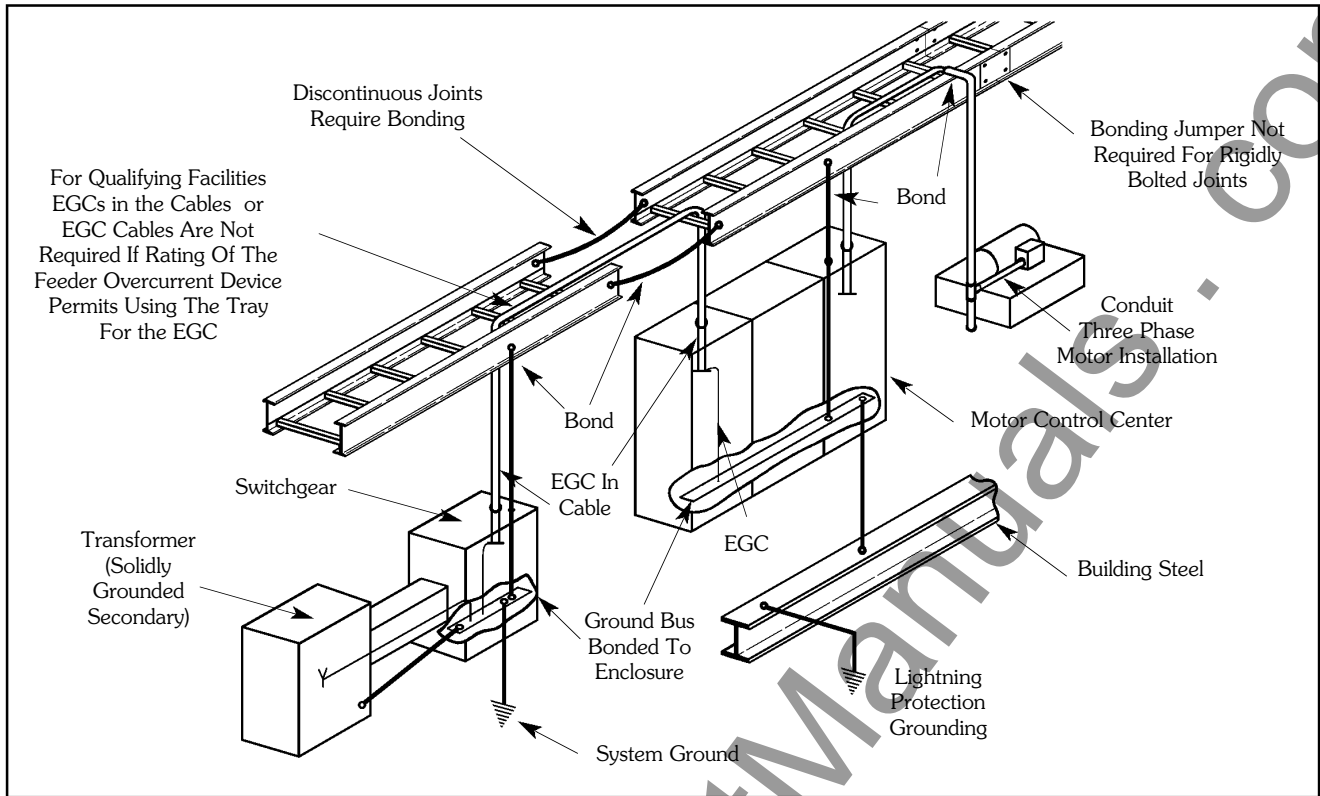

Correct Bonding Practices To Assure That The Cable Tray System Is Properly Grounded

If an EGC cable is installed in or on a cable tray, it should be bonded to each or alternate cable tray sections via grounding clamps (this is not required by the **NEC**[®] but it is a desirable practice). In addition to providing an electrical connection between the cable tray sections and the EGC, the grounding clamp mechanically anchors the EGC to the cable tray so that under fault current conditions the magnetic forces do not throw the EGC out of the cable tray.

A bare copper equipment grounding conductor should not be placed in an aluminum cable tray due to the potential for electrolytic corrosion of the aluminum cable tray in a moist environment. For such installations, it is best to use an insulated conductor and to remove the insulation where bonding connections are made to the cable tray, raceways, equipment enclosures, etc. with tin or zinc plated connectors.

See Table 250.122 on page 51 for the minimum size EGC for grounding raceway and equipment.

392.7. Grounding. (B) Steel or Aluminum Cable Tray Systems. (1) & (2)

**Table 392.7(B).
Metal Area Requirements for Cable Trays
Used as Equipment Grounding Conductors**

Maximum Fuse Ampere Rating, Circuit Breaker Ampere Trip Setting, or Circuit Breaker Protective Relay Ampere Trip Setting for Ground-Fault Protection of Any Cable Circuit In the Cable Tray System	Minimum Cross-Sectional Area of Metal* In Square Inches	
	Steel Cable Trays	Aluminum Cable Trays
60	0.20	0.20
100	0.40	0.20
200	0.70	0.20
400	1.00	0.40
600	1.50**	0.40
1000	---	0.60
1200	---	1.00
1600	---	1.50
2000	---	2.00**

For SI units: one square inch = 645 square millimeters.

*Total cross-sectional area of both side rails for ladder or trough cable trays; or the minimum cross-sectional area of metal in channel cable trays or cable trays of one-piece construction.

**Steel cable trays shall not be used as equipment grounding conductors for circuits with ground-fault protection above 600 amperes. Aluminum cable trays shall not be used as equipment grounding conductors for circuits with ground-fault protection above 2000 amperes.

Reprinted with permission from NFPA 70-1999, the National Electrical Code®, Copyright© 1998, National Fire Protection Association, Quincy, MA 02269. This reprinted material is not the complete and official position of the National Fire Protection Association, on the referenced subject which is represented only by the standard in its entirety.

Table 392.7(B) "Metal Area Requirements for Cable Trays used as Equipment Grounding Conductors" shows the minimum cross-sectional area of cable tray side rails (total of both side rails) required for the cable tray to be used as the Equipment Grounding Conductor (EGC) for a specific Fuse Rating, Circuit Breaker Ampere Trip Rating or Circuit Breaker Ground Fault Protective Relay Trip Setting. These are the actual trip settings for the circuit breakers and not the maximum permissible trip settings which in many cases are the same as the circuit breaker frame size. If the maximum ampere rating of the cable tray is not sufficient for the protective device to be used, the cable tray cannot be used as the EGC and a separate EGC must be included within each cable assembly or a separate EGC has to be installed in or attached to the cable tray. [See also Section 250-120 for additional information]

The subject of using cable tray for equipment grounding conductors was thoroughly investigated by the 1973 **NEC**® Technical Subcommittee on Cable Tray. Many calculations were made and a number of tests were performed by Monsanto Company Engineers at the Bussman High Current Laboratory. The test setup to verify the capability of cable tray to be used as the EGC is shown in Figure 1 on page 29. The test amperes available were forced through one cable tray side rail which had three splice connections in series. No conductive joint compound was used at the connections and the bolts were wrench tight. Copper jumper cables were used from the current source to the cable tray. The cable tray was NEMA Class 12B. The test results are shown on Page 45 (Appendix Sheet 1), Table I for aluminum and Table II for steel cable tray.

One of the most interesting results of the tests was for an aluminum cable tray with a corroded joint and only two nylon bolts. 34,600 amperes for 14 cycles produced only a 34° C temperature rise at the splice plate area. If the protective devices work properly, the temperature rises recorded at the cable tray splices during these tests would not be sufficient to damage the cables in the cable tray. Also note that in these tests only one side rail was used, but in a regular installation, both side rails would conduct fault current and the temperature rise at the splice plate areas would be even lower.

When the cable tray is used as the EGC, consideration has to be given to the conduit or ventilated channel cable tray connections to the cable tray so that the electrical grounding continuity is maintained from the cable tray to the equipment utilizing the electricity. Conduit connections to the cable tray were also tested. At that time, no commercial fittings for connecting conduit to cable tray were available, so right angle beam clamps were used with very good results. There are now UL Listed fittings for connecting and bonding conduit to cable tray. This test setup and results are shown on page 46 (Appendix Sheet 2).

Temperature Rise Test

Material Thickness: 0.125" Aluminum or 14 Gauge Steel

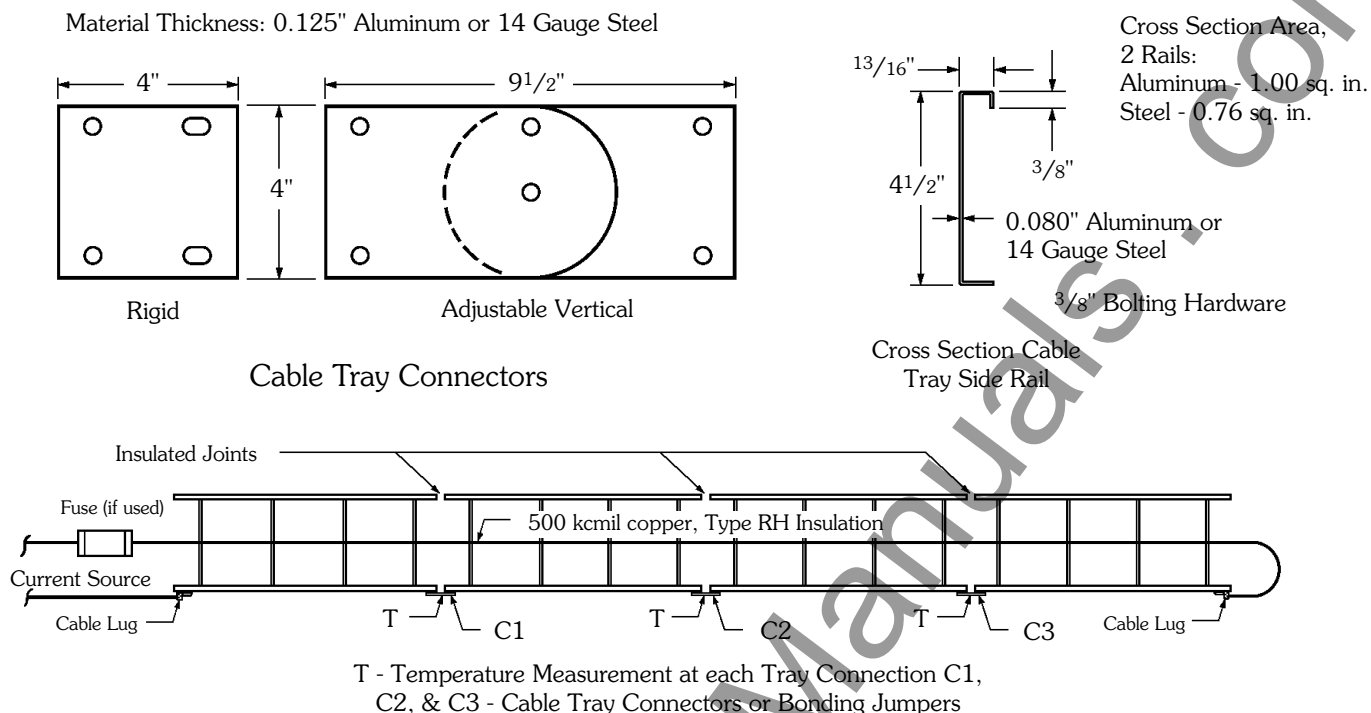

Figure 1
(See Page 45 Appendix Sheet 1)

392.7. Grounding. (B) Steel or Aluminum Cable Tray Systems. (3) & (4)

For a cable tray to be used as an EGC the manufacturer must provide a label showing the cross-sectional area available. This also holds true for some mechanically constructed cable tray systems such as Redi-Rail®. Redi-Rail has been tested and UL Classified as an EGC. B-Line's label is shown at the top of page 30.

The cable tray system must be electrically continuous whether or not it is going to serve as the EGC. At certain locations (expansion joints, discontinuities, most horizontal adjustable splice plates, etc.), bonding jumpers will be required. Section 250.96. Bonding Other Enclosures states that cable tray shall be effectively bonded where necessary to assure electrical continuity and to provide the capacity to conduct safely any fault current likely to be imposed on them (also see Sections 250.92(A)(1) & 250.118(12)).

It is not necessary to install bonding jumpers at standard splice plate connections. The splice connection is UL classified as an EGC component of the cable tray system.

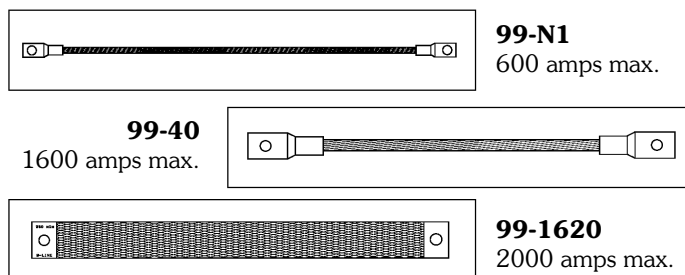
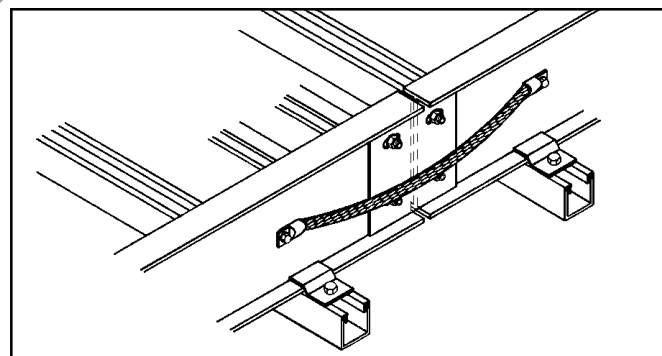

NOTE: The **NEC**® only recognizes aluminum and steel cable trays as EGC's. As with all metallic cable trays, stainless steel cable trays must be bonded according to **NEC**® guidelines. Fiberglass cable trays do not require bonding jumpers since fiberglass is non-conductive.

Cable Tray Label

<h1 style="margin: 0;">WARNING!</h1> <p style="margin: 0;">Do Not Use As A Walkway, Ladder, Or Support For Personnel.</p> <p style="margin: 0;">Use Only As A Mechanical Support For Cables, Tubing and Raceways.</p>		<div style="display: flex; justify-content: space-between;"> Catalog Number: 24A09-12-144 STR SECTION <small>(and description)</small> 1 of 1 VENTILATED 09/05/2002 </div> <div style="display: flex; justify-content: space-between;"> Shipping Ticket: 260203 00 001 B-Line </div> <div style="display: flex; justify-content: space-between;"> Mark Number: 78101115400 816 LIONS DRIVE </div> <div style="display: flex; justify-content: space-between;"> Purchase Order: D798981 TROY, IL 62294 </div> <div style="display: flex; justify-content: space-between;"> Minimum Area: 1.000 SQ. IN. (618) 667-6779 </div> <div style="display: flex; justify-content: space-between;"> Load Class: D1 179 KG/M 3 METER SPAN </div> <div style="text-align: center; font-size: 0.8em;"> REFERENCE FILE # LR360266 </div> <div style="font-size: 0.8em;"> This product is classified by Underwriters Laboratories, Inc. as to its suitability as an equipment grounding conductor only. 556E </div>
		<p style="font-size: 0.8em; margin-top: 5px;">30781011154005</p>

392.8. Cable Installation. (A) Cable Splices.

There is no safety problem due to cable splices being made in cable trays if quality splicing kits are used, provided that the splice kits do not project above the siderails and that they are accessible. A box or fitting is not required for a cable splice in a cable tray.

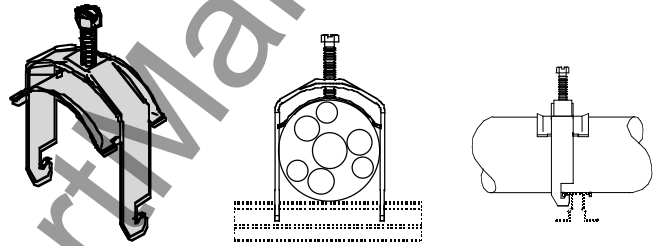

(P-Clamp shown installed on industrial aluminum rung)

392.8. Cable Installation. (B) Fastened Securely.

In seismic, high-shock and vibration prone areas, cables (especially unarmored cables) should be secured to the cable tray at 1 to 2 foot intervals to prevent the occurrence of sheath chafing. Otherwise, there is no safety or technical reason to tie down multiconductor cables in horizontal cable tray runs unless the cable spacing needs to be maintained or the cables need to be confined to a specific location in the cable tray. In non-horizontal cable tray runs, small multiconductor cables should be tied down at 3 or 4 foot intervals and larger (1 inch diameter and above) Type MC and Type TC multiconductor cable should be tied down at 6 foot intervals. If used outdoors, plastic ties should be sunlight, ultraviolet (UV), resistant and be made of a material that is compatible with the industrial environment. Installed outdoors, white nylon plastic ties without a UV resistant additive will last 8 to 14 months before breaking. Also available for these applications are cable cleats, stainless steel ties and P-clamps.

392.8. Cable installation. (C) Bushed Conduit and Tubing.

For most installations, using a conduit to cable tray clamp for terminating conduit on cable tray is the best method. Where a cable enters a conduit from the cable tray, the conduit must have a bushing to protect the cable jacket from mechanical damage; a box is not required [See Section 300.15(C). Boxes, Conduit Bodies, or Fittings - Where Required. Where cables enter or exit from conduit or tubing that is used to provide cable support or protection against physical damage. A fitting shall be provided on the end(s) of the conduit or tubing to protect the wires or cables from abrasion.]. There are some special installations where the use of conduit knockouts in the cable tray side rail for terminating conduit is appropriate. This would not be a good standard practice because it is costly and labor intensive, and if randomly used may result in damaging and lowering the strength of the cable tray.

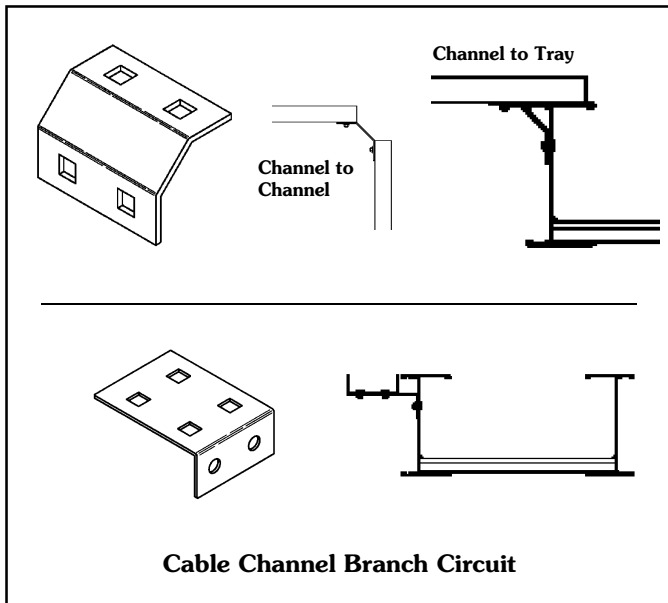

392.8. Cable Installation. (D) Connected in Parallel.

Section 310.4. Conductors in Parallel. States the following:

The paralleled conductors in each phase, neutral or grounded conductor shall:

- (1) Be the same length.
- (2) Have the same conductor material.
- (3) Be the same size in circular mil area.
- (4) Have the same insulation type.
- (5) Be terminated in the same manner.

Where run in separate raceways or cables, the raceways or cables shall have the same physical characteristics. Conductors of one phase, neutral, or grounded circuit shall not be required to have the same physical characteristics as those of another phase, neutral, or grounded circuit conductor to achieve balance.

A difference between parallel conductors in raceways and those in cable trays is that the conductors in the cable tray are not derated unless there are more than three current carrying conductors in a cable assembly [as per Exception No.2 of Section 310.15(B)(2)(a) and Section 392.11(A)(1)]. Where the single conductor cables are bundled together as per Section 392.8(D) and if there are neutrals that are carrying currents due to the type of load involved (harmonic currents) it may be prudent to derate the bundled single conductor cables.

The high amperages flowing under fault conditions in 1/0 and larger cables produce strong magnetic fields which result in the conductors repelling each

other until the circuit protective device either de-energizes the circuit or the circuit explodes. Under such fault conditions, the cables thrash violently and might even be forced out of the cable tray. This happened at a northern Florida textile plant where several hundred feet of Type MV single conductor cable was forced out of a cable tray run by an electrical fault because the cables were not restrained properly. This potential safety threat is precisely why Article 392.8 (D) requires single conductor cables be securely bound in circuit groups to prevent excessive movement due to fault-current magnetic forces. For a three-phase triplex or trefoil arrangement (the most common single conductor application), these forces can be calculated according to the formula:

$$F_t = (0.17 \times i_p^2) / S.$$

F_t = Maximum Force on Conductor (Newtons/meter)

i_p = Peak Short Circuit Current (kilo-Amperes)

S = Spacing between Conductors (meters) = Cable Outside Diameter for Triplex (trefoil) Installations.

One technique to prevent excessive movement of cables is to employ fault-rated cable cleats.

To maintain the minimum distance between conductors, the single conductor cables should be securely bound in circuit groups using fault rated cable cleats. If the cleat spacing is properly chosen according to the available fault-current, the resulting cable grouping will inherently maintain a minimum distance between conductors. These circuit groups provide the lowest possible circuit reactance which is a factor in determining the current balance among various circuit groups.

For installations that involve phase conductors of three conductor or single conductor cables installed in parallel, cable tray installations have conductor cost savings advantages over conduit wiring systems. This is because the conductors required for a cable tray wiring system are often a smaller size than those required for a conduit wiring system for the same circuit. No paralleled conductor ampacity adjustment is required for single conductor or three conductor cables in cable trays [See NEC® Section 392.11(A)].

There were changes in the 1993 NEC® and 1996 NEC® for installations where an equipment grounding conductor is included in a multiconductor cable: the equipment grounding conductor must be fully rated per Section 250.122. If multiconductor cables with internal equipment grounding conductors are paralleled, each multiconductor cable must have a fully rated equipment grounding conductor.

Reprinted with permission from NFPA 70-1999, the National Electrical Code®, Copyright© 1998, National Fire Protection Association, Quincy, MA 02269. This reprinted material is not the complete and official position of the National Fire Protection Association, on the referenced subject which is represented only by the standard in its entirety.

Section 250.122 now prohibits the use of standard three conductor cables with standard size EGCs when they are installed in parallel and the EGCs are paralleled. There have been no safety or technical problems due to operating standard three conductor cables with standard sized EGCs in parallel. This has been a standard industrial practice for over 40 years with large numbers of such installations in service. This change was made without any safety or technical facts to justify this change.

To comply with Section 250.122, Three options are available: 1. Order special cables with increased sized EGCs which increases the cost and the delivery time. 2. Use three conductor cables without EGCs and install a single conductor EGC in the cable tray or use the cable tray as the EGC in qualifying installations. 3. Use standard cables but don't utilize their EGCs, use a single conductor EGC or the cable tray as the EGC in qualifying installations.

Should industry be required to have special cables fabricated for such installations when there have been absolutely no safety problems for over 40 years? Each designer and engineer must make his own decision on this subject. If the installations are properly designed, quality materials are used, and quality workmanship is obtained, there is no safety reason for not following the past proven practice of paralleling the EGCs of standard three conductor cable.

392.8. Cable Installation. (E) Single Conductors.

This section states that single conductors in ladder or ventilated trough cable tray that are Nos. 1/0 through 4/0, must be installed in a single layer.

In addition to the fill information that is in Section 392.10(A)(4), an exception was added which allows the cables in a circuit group to be bound together rather than have the cables installed in a flat layer. The installation practice in the exception is desirable to help balance the reactance's in the circuit group. This reduces the magnitudes of voltage unbalance in three phase circuits.

Where ladder or ventilated trough cable trays contain multiconductor power or lighting cables, or any mixture of multiconductor power, lighting, control, or signal cables, the maximum number of cables that can be installed in a cable tray are limited to the Table 392.9 allowable fill areas. The cable tray fill areas are related to the cable ampacities. Overfill

Compatibility Of Cable Tray Types And Cable Trays Based On The NEC®

	3", 4", & 6" Wide Solid or Ventiladed Channel Cable Tray	Solid Bottom Cable Tray	Ventilated Trough Cable Tray	Ladder Cable Tray
Multiconductor Cables 300 & 600 Volt *	X	X	X	X
Single Conductor Cables - 600 Volt *	***	X		X
Type MV Multiconductor Cables **	X	X		X
Type MV Single Conductor Cables **	X	X		X

X - Indicates the Installations Allowed by Article 392

* - For cables rated up to 2000 volts.

** - For cables rated above 2000 volts.

*** - For 1/0 - 4/0 AWG single conductor cables installed in ladder cable tray, maximum rung spacing is 9 inches.

of the cable tray with the conductors operating at their maximum ampacities will result in cable heat dissipation problems with the possibility of conductor insulation and jacket damage.

392.9. Number of Multiconductor Cables. Rated 2000 Volts or less, in Cable Trays. (A) Any Mixture of Cables. (1) 4/0 or Larger Cables

The ladder or ventilated trough cable tray must have an inside usable width equal to or greater than the sum of the diameters (Sd) of the cables to be installed in it. For an example of the procedure to use in selecting a cable tray width for the type of cable covered in this section see page 47 (Appendix Sheet 3), [Example 392.9(A)(1)].

Increasing the cable tray side rail depth increases the strength of the cable tray but the greater side rail depth does not permit an increase in cable fill area for power or lighting cables or combinations of power, lighting, control and signal cables. The maximum allowable fill area for all cable tray with a 3 inch or greater loading depth side rail is limited to the 38.9 percent fill area for a 3 inch loading depth

side rail (Example: 3 inches x 6 inches inside cable tray width x 0.389 = 7.0 square inch fill area. This is the first value in Column 1 of Table 392.9. All succeeding values for larger cable tray widths are identically calculated).

392.9. Number of Multiconductor Cables. Rated 2000 Volts or less, in Cable Trays. (A) Any Mixture of Cable. (2) Cables Smaller Than 4/0

The allowable fill areas for the different ladder or ventilated trough cable tray widths are indicated in square inches in Column 1 of Table 392.9. The total sum of the cross-sectional areas of all the cables to be installed in the cable tray must be equal to or less than the cable tray allowable fill area. For an example of the procedure to use in selecting a cable tray width for the type of cable covered in this section see page 48 (Appendix Sheet 4), [Example 392.9(A)(2)].

392.9. Number of Multiconductor Cables. Rated 2000 Volts or less, in Cable Trays. (A) Any Mixture of Cables. (3) 4/0 or Larger Cables Installed With Cables Smaller Than 4/0

The ladder or ventilated trough cable tray needs to be divided into two zones (a barrier or divider is not required but one can be used if desired) so that the No. 4/0 and larger cables have a dedicated zone as they are to be placed in a single layer.

The formula for this type of installation is shown in Column 2 of Table 392.9. This formula is a trial and error method of selecting a cable tray of the proper width. A direct method for determining the cable tray width is available by figuring the cable tray widths that are required for each of the cable combinations and then adding these widths together to select the proper cable tray width. [Sd (sum of the diameters of the No. 4/0 and larger cables)] + [Sum of Total Cross Sectional Area of all Cables No. 3/0 and Smaller) x (6 inches/7 square inches)] = The Minimum Width of Cable Tray Required. For an example of the procedure to use in selecting a cable tray width for the type of cable covered in this section, see page 49, (Appendix Sheet 5), [EXAMPLE 392.9(A)(3)].

392.9. Number of Multiconductor Cables. Rated 2000 Volts or less, in Cable Trays. (B) Multiconductor Control and/or Signal Cables Only.

A ladder or ventilated trough cable tray, having a loading depth of 6 inches or less containing only control and/or signal cables, may have 50 percent of its cross-sectional area filled with cable. If the cable tray has a loading depth in excess of 6 inches, that figure cannot be used in calculating the allowable fill area as a 6 inch depth is the maximum value that can be used for the cross-sectional area calculation. For an example of the procedure to use in selecting a cable tray width for the type of cable covered in this section, see page 50 (Appendix Sheet 6), [Example 392.9 (B)].

392.9. Number of Multiconductor Cables, Rated 2000 Volts, Nominal, or Less, in Cable Trays. (C) Solid Bottom Cable Trays Containing Any Mixture.

For solid bottom cable tray, the allowable cable fill area is reduced to approximately 30 percent as indicated by the values in Columns 3 and 4 of Table 392.9. The first value in Column 3 was obtained as follows: 3 in. loading depth x 6 in. inside width x 0.305 = 5.5 square inches. The other values in Column 3 were obtained in a like manner. The Sd term in Column 4 has a multiplier of 1 vs. the multiplier of 1.2 for Column 2.

392.9. Number of Multiconductor Cables, Rated 2000 Volts, Nominal, or Less, in Cable Trays. (C) Solid Bottom Cable Trays Containing any Mixture. (1) 4/0 or Larger Cables

The procedure used in selecting a cable tray width for the type of cable covered in this section is similar to that shown on Appendix Sheet 3 page 47, but only 90 percent of the cable tray width can be used.

392.9. Number of Multiconductor Cables, Rated 2000 Volts, Nominal, or Less, in Cable Trays. (C) Solid Bottom Cable Trays Containing Any Mixture. (2) Cables Smaller Than 4/0

The procedure used in selecting a cable tray width for the type of cable covered in this section is similar to that shown on Appendix Sheet 4 page 48. The maximum allowable cable fill area is in Column 3 of Table 392.9.

392.9. Number of Multiconductor Cables, Rated 2000 Volts, Nominal, or Less, in Cable Trays. (C) Solid Bottom Cable Trays Containing any Mixture. (3) 4/0 or Larger Cables Installed With Cables Smaller Than 4/0

No. 4/0 and larger cables must have a dedicated zone in the tray in order to be installed in one layer. Therefore the cable tray needs to be divided into two zones (a barrier or divider is not required but one can be used if desired).

The formula for this type of installation is shown in Column 4 of Table 392.9. This formula is a trial and error method of selecting a cable tray of the proper width. A direct method for determining the cable tray width is available by figuring the cable tray widths that are required for each of the cable combinations and then adding these widths together to select the proper cable tray width. $[Sd \text{ (sum of the diameters of the No. 4/0 and larger cables)} \times (1.11)] + [(Sum \text{ of Total Cross-Sectional Area of all Cables No. 3/0 and Smaller)} \times (6 \text{ inches}/5.5 \text{ square inches}) = \text{The Minimum Width of Cable Tray Required.}$ The procedure used in selecting a cable tray width for the type of cables covered in this section is similar to that shown on Appendix Sheet 5 page 49.

392.9. Number of Multiconductor Cables, Rated 2000 Volts, Nominal, or Less, in Cable Trays. (D) Solid Bottom Cable Tray Multiconductor Control and/or Signal Cables Only.

This is the same procedure as for ladder and ventilated trough cable trays except that the allowable fill has been reduced from 50 percent to 40 percent. The procedure used in selecting a cable

tray width for the type of cable covered in this section is similar to that shown on Appendix Sheet 6 page 50. [Example 392.9(B)]

392.9. Number of Multiconductor Cables, Rated 2000 Volts, Nominal, or Less in Cable Trays. (E) Ventiladed Channel Cable Trays.

392.9(E)(1)

Where only one multiconductor cable is installed in a ventilated channel cable tray.

Ventilated Channel Cable Tray Size	Maximum Cross-Sectional Area of the Cable
3 Inch Wide	2.3 Square Inches
4 Inch Wide	4.5 Square Inches
6 Inch Wide	7.0 Square Inches

392.9(E)(2)

The fill areas for combinations of multiconductor cables of any type installed in ventilated channel cable tray.

Ventilated Channel Cable Tray Size	Maximum Allowable Fill Area
3 Inch Wide	1.3 Square Inches
4 Inch Wide	2.5 Square Inches
6 Inch Wide	3.8 Square Inches

392.9. Number of Multiconductor Cables, Rated 2000 Volts, Nominal, or Less in Cable Trays. (F) Solid Channel Cable Trays.

392.9(F)(1)

Where only one multiconductor cable is installed in a solid channel cable tray.

Solid Channel Cable Tray Size	Maximum Cross-Sectional Area of the Cable
2 Inch Wide	1.3 Square Inches
3 Inch Wide	2.0 Square Inches
4 Inch Wide	3.7 Square Inches
6 Inch Wide	5.5 Square Inches

392.9(F)(2)

The fill areas for combinations of multiconductor cables of any type installed in solid channel cable tray.

Solid Channel Cable Tray Size	Maximum Allowable Fill Area
2 Inch Wide	0.8 Square Inches
3 Inch Wide	1.1 Square Inches
4 Inch Wide	2.1 Square Inches
6 Inch Wide	3.2 Square Inches

392.10. Number of Single Conductor Cables, Rated 2000 Volts or Less in Cable Trays.

Installation of single conductors in cable tray is restricted to industrial establishments where conditions of maintenance and supervision assure that only qualified persons will service the installed cable tray systems. Single conductor cables for these installations must be 1/0 or larger, and they may not be installed in solid bottom cable trays.

392.10. Number of Single Conductor Cables, Rated 2000 Volts or Less in Cable Trays. (A) Ladder or Ventilated Trough Cable Trays. (1) 1000 KCMIL or Larger Cables

The sum of the diameters (Sd) of all single conductor cables shall not exceed the cable tray width, and the cables shall be installed in a single layer.

392.10. Number of Single Conductor Cables, Rated 2000 Volts or Less, in Cable Trays. (A) Ladder or Ventilated Trough Cable Trays. (2) 250 KCMIL to 1000 KCMIL Cables

Number Of 600 Volt Single Conductor Cables That May Be Installed In Ladder Or Ventilated Trough Cable Tray - Section 392.10(A) (2)

Single Conductor Size	Dia. In. (Note #1)	Area Sq. In.	Cable Tray Width								(Note #2) 42 In.
			6 In.	9 In.	12 In.	18 In.	24 In.	30 In.	36 In.		
1/0	0.58	--	10	15	20	31	41	51	62	72	
2/0	0.62	--	9	14	19	29	38	48	58	67	
3/0	0.68	--	8	13	17	26	35	44	52	61	
4/0	0.73	--	8	12	16	24	32	41	49	57	
250 Kcmil	0.84	0.55	11	18	24	35	47	59	71	82	
350 Kcmil	0.94	0.69	9	14	19	28	38	47	57	65	
500 Kcmil	1.07	0.90	7	11	14	22	29	36	43	50	
750 Kcmil	1.28	1.29	5	8	10	15	20	25	30	35	
1000 Kcmil	1.45	--	4	6	8	12	16	20	24	28	

Notes:

- #1. Cable diameter's used are those for Okonite-Okolon 600 volt single conductor power cables.
- #2. 42 inch wide is ladder cable tray only.
- #3. Such installations are to be made only in qualifying industrial facilities as per Sections 392.3(B) & (B)(1).
- #4. To avoid problems with unbalanced voltages, the cables should be bundled with ties every three feet or four feet. The bundle must contain the circuit's three phase conductors plus the neutral if one is used.
- #5. The single conductor cables should be firmly tied to the cable trays at six foot or less intervals.

392.10. Number of Single Conductor Cables, Rated 2000 Volts or Less in Cable Trays. (A) Ladder or Ventilated Trough Cable Trays. (3) 1000 KCMIL or Larger Cables Installed With Cables Smaller Than 1000 KCMIL.

Such installations are very rare.

392.10. Number of Single Conductor Cables, Rated 2000 Volts or Less in Cable Trays. (A) Ladder or Ventilated Trough Cable Trays. (4) Cables 1/0 Through 4/0

The sum of the diameters (Sd) of all 1/0 through 4/0 cables shall not exceed the inside width of the cable tray.

392.10. Number of Single Conductor Cables, Rated 2000 Volts or Less in Cable Trays. (B) Ventilated Channel Cable Trays.

The sum of the diameters (Sd) of all single conductors shall not exceed the inside width of the ventilated cable channel.

Number Of 600 Volt Single Conductor Cables That May Be Installed In A Ventilated Channel Cable Tray - Section 392.10(B)

Single Conductor Size	Diameter Inches (Note #1)	3 Inch V. Channel C.T.	4 Inch V. Channel C.T.	6 Inch V. Channel C.T.
1/0 AWG	0.58	5	6	10
2/0 AWG	0.62	4	6	9
3/0 AWG	0.68	4	5	8
4/0 AWG	0.73	4	5	8
250 Kcmil	0.84	3	4	7
350 Kcmil	0.94	3	4	6
500 Kcmil	1.07	2	3	5
750 Kcmil	1.28	2	3	4
1000 Kcmil	1.45	2	2	4

Notes:

- #1. Cable diameter's used are those for Okonite-Okolon 600 volt single conductor power cables.
- #2. Such installations are to be made only in qualifying industrial facilities as per Sections 392.3(B) & (B)(1).
- #3. The phase, neutral, and EGCs cables are all counted in the allowable cable fill for the ventilated channel cable tray.
- #4. To avoid problems with unbalanced voltages, the cables should be bundled with ties every three feet or four feet. The bundle must contain the circuit's three phase conductors plus the neutral if one is used. If a cable is used as the EGC, it should also be in the cable bundle. If the designer desires, the ventilated channel cable tray may be used as the EGC as per Table 392.7(B)(2).
- #5. The single conductor cables should be firmly tied to the ventilated channel cable tray at six foot or less intervals.

392.11. Ampacity of Cables Rated 2000 Volts or Less in Cable Trays. (A) Multiconductor Cables.

Ampacity Tables 310.16 and 310.18 are to be used for multiconductor cables which are installed in cable tray using the allowable fill areas as per Section

392.9. The ampacities in Table 310.16 are based on an ambient temperature of 30° Celsius. Conduit and cable tray wiring systems are often installed in areas where they will be exposed to high ambient temperatures. For such installations, some designers and engineers neglect using the Ampacity Correction Factors listed below the Wire Ampacity Tables which results in the conductor insulation being operated in excess of its maximum safe temperature. These correction factors must be used to derate a cable for the maximum temperature it will be subjected to anywhere along its length.

392.11(A)(1)

Section 310.15(B)(2)(a) refers to Section 392.11 which states that the derating information of Table 310.15(B)(2)(a) applies to multiconductor cables with more than three current carrying conductors but not to the number of conductors in the cable tray.

392.11(A)(2)

Where cable trays are continuously covered for more than 6 feet (1.83m) with solid unventilated covers, not over 95 percent of the allowable ampacities of Tables 310.16 and 310.18 shall be permitted for multiconductor cables.

This is for multiconductor cables installed using Table 392.16 or 392.18. If these cables are installed in cable trays with solid unventilated covers for more than 6 feet the cables must be derated. Where cable tray covers are to be used, it is best to use raised or ventilated covers so that the cables can operate in a lower ambient temperature.

392.11(A)(3)

Where multiconductor cables are installed in a single layer in uncovered trays, with a maintained spacing of not less than one cable diameter between cables, the ampacity shall not exceed the allowable ambient temperature corrected ampacities of multiconductor cables, with not more than three insulated conductors rated 0-2000 volts in free air, in accordance with Section 310.15(C).

By spacing the cables one diameter apart, the engineer may increase the allowable ampacities of the cables to the free air rating as per Section 310.15(C) and Table B-310.3 in Appendix B. Notice that the allowable fill of the cable tray has been decreased in this design due to the cable spacing.

392.11. Ampacity of Cables Rated 2000 Volts or Less in Cable Trays. (B) Single Conductor Cables.

Single conductor cables can be installed in a cable tray cabled together (triplexed, quadruplexed, etc.) if desired. Where the cables are installed according to the requirements of Section 392.10, the ampacity requirements are shown in the following chart as per Section 392.11(B)(1), (2), (3), & (4):

The 2005 **NEC**[®] has added a new exception to 392.11(B)(3). Stating that the capacity for single conductor cables be placed in solid bottom shall be determined by 310.15(C).

Sec. No.	Cable Sizes	Solid Unventilated Cable Tray Cover	Applicable Ampacity Tables (*)	Mult. Amp. Table Values By	Special Conditions
(1)	600 kcmil and Larger	No Cover Allowed (**)	310.17 and 310.19	0.75	
(1)	600 kcmil and Larger	Yes	310.17 and 310.19	0.70	
(2)	1/0 AWG through 500 kcmil	No Cover Allowed (**)	310.17 and 310.19	0.65	
(2)	1/0 AWG through 500 kcmil	Yes	310.17 and 310.19	0.60	
(3)	1/0 AWG & Larger In Single Layer	No Cover Allowed (**)	310.17 and 310.19	1.00	Maintained Spacing Of One Cable Diameter
(4)	Single Conductors In Triangle Config. 1/0 AWG and Larger	No Cover Allowed (**)	310.20 [See NEC Section 310.15(B)]	1.00	Spacing Of 2.15 x One Conductor O.D. Between Cables(***)

(*) The ambient ampacity correction factors must be used.

(**) At a specific position, where it is determined that the tray cables require mechanical protection, a single cable tray cover of six feet or less in length can be installed.

The wording of Section 392.11(B)(4) states that a spacing of 2.15 times one conductor diameter is to be maintained between circuits. Two interpretations of this statement are possible. Interpretation #1. - The 2.15 times one conductor diameter is the distance between the centerlines of the circuits (the center lines of the conductor bundles). Interpretation #2. - The 2.15 times one conductor diameter is the free air distance between the adjacent cable bundles. The use of the word "circuit" is unfortunate as its presence promotes Interpretation #1. An installation based on Interpretation #1 is not desirable as a free air space equal to 2.15 times one conductor diameter between the cable bundles should be maintained to promote cable heat dissipation.

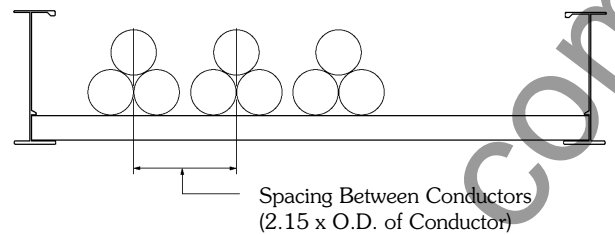

Technically Undesirable Installation

Interpretation #1

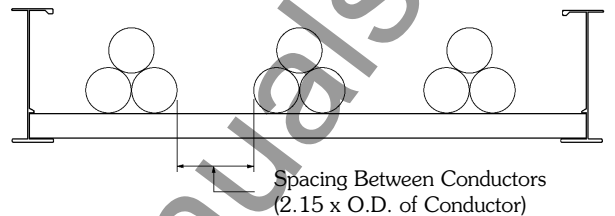

Technically Desirable Installation

Interpretation #2

392.12. Number of Type MV and Type MC Cables (2001 Volts or Over) in Cable Trays.

Sum the diameters of all the cables (Sd) to determine the minimum required cable tray width. Triplexing or quadruplexing the cables does not change the required cable tray width. Whether the cables are grouped or ungrouped, all installations must be in a single layer.

392.13. Ampacity of Type MV and Type MC Cables (2001 Volts or Over) in Cable Trays. (A) Multiconductor Cables (2001 Volts or Over).

Provision No. 1: Where cable trays are continuously covered for more than six feet (1.83 m) with solid unventilated covers, not more than 95% of the allowable ampacities of Tables 310.75 and 310.76 shall be permitted for multiconductor cables.

Cables installed in cable trays with solid unventilated covers must be derated. Where cable tray covers are to be used, it is best to use raised or ventilated covers so that the cables can operate in a lower ambient temperature.

Provision No. 2: Where multiconductor cables are installed in a single layer in uncovered cable trays with a maintained spacing of not less than one cable diameter between cables, the ampacity shall not exceed the allowable ampacities of Table 310.71 and 310.72.

If the cable tray does not have covers and the conductors are installed in a single layer spaced not less than one cable diameter apart, the cable conductor ampacities can be 100 percent of the ambient temperature corrected capacities in Tables 310.71 or 310.72.

392.13. Ampacity of Type MV and Type MC Cables (2001 Volts or Over) in Cable Trays. (B) Single Conductor Cables (2001 Volts or Over).

Sec. No.	Cable Sizes	Solid Unventilated Cable Tray Cover	Applicable Ampacity Tables (*)	Mult. Amp. Table Values By	Special Conditions
(1)	1/0 AWG and Larger	No Cover Allowed (**)	310.69 and 310.70	0.75	
(1)	1/0 AWG and Larger	Yes	310.69 and 310.70	0.70	
(2)	1/0 AWG & Larger In Single Layer	No Cover Allowed (**)	310.69 and 310.70	1.00	Maintained Spacing Of One Cable Diameter
(3)	Single Conductors In Triangle Config. 1/0 AWG and Larger	No Cover Allowed (**)	310.67 and 310.68	1.00	Spacing Of 2.15 x One Conductor O.D. Between Cables(***)

(*) The ambient ampacity correction factors must be used.

(**) At a specific position, where it is determined that the tray cables require mechanical protection, a single cable tray cover of six feet or less in length can be installed.

The wording of Section 392.13(B)(3) states that a spacing of 2.15 times one conductor diameter is to be maintained between circuits. Two interpretations of this statement are possible. Interpretation #1. - The 2.15 times one conductor diameter is the distance between the centerlines of the circuits (the center lines of the conductor bundles). Interpretation #2. - The 2.15 times one conductor diameter is the free air distance between the adjacent cable bundles. The use of the word "circuit" is unfortunate as its presence promotes Interpretation #1. An installation based on Interpretation #1 is not desirable as a free air space equal to 2.15 times one conductor diameter between the cable bundles should be maintained to promote cable heat dissipation.

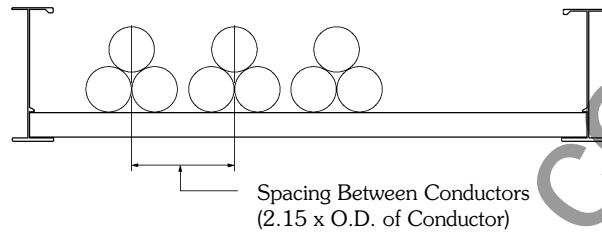

Technically Undesirable Installation

Interpretation #1

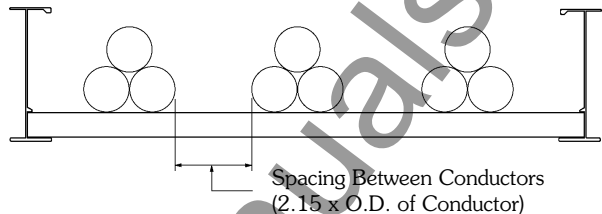

Technically Desirable Installation

Interpretation #2

CABLE TRAY WIRING SYSTEM DESIGN AND INSTALLATION HINTS.

Cable tray wiring systems should have a standardized cabling strategy. Standard cable types should be used for each circuit type. Most of the following circuits should be included; feeder circuits, branch circuits, control circuits, instrumentation circuits, programmable logic controller input and output (I/O) circuits, low level analog or digital signals, communication circuits and alarm circuits. Some cables may satisfy the requirements for several circuit types. Minimizing the number of different cables used on a project reduces installed costs. Some companies have cable standards based on volume usage to minimize the numbers of different cables used on a project. For example: if a 6 conductor No. 14 control cable is needed but 7 conductor No. 14 control cable is stocked, a 7 conductor control cable would be specified and the extra conductor would not be used. Following such a practice can reduce the number of different cables handled on a large project without increasing the cost since high volume cable purchases result in cost savings. Orderly record keeping also helps provide quality systems with lower installation costs. The following items should be included in the project's cable records:

- Cable Tray Tag Numbers - The tagging system should be developed by the design personnel with identification numbers assigned to cable tray runs on the layout drawings. Cable tray tag numbers are used for controlling the installation of the proper cable tray in the correct location, routing cables through the tray system and controlling the cable fill area requirements.

- Cable Schedules - A wire management system is required for any size project. Cable schedules must be developed to keep track of the cables. This is especially true for projects involving more than just a few feeder cables. A typical cable schedule would contain most or all of the following:

- The Cable Number, the Cable Manufacturer & Catalog Number, Number of conductors, the conductor sizes, and the approximate cable length.

- Cable Origin Location - The origin equipment ID with the compartment or circuit number and terminals on which the cable conductors are to be terminated. It should also include the origin equipment layout drawing number, and the origin equipment connection diagram number.

- Cable Routing - Identifies the cable tray sections or runs that a cable will occupy. Cable tray ID tag numbers are used to track the routing.

- Cable Termination Location - The device or terminal equipment on which the cable conductors are to be terminated. It should also include the termination equipment layout drawing number, and the termination equipment connection diagram number.

Some design consultants and corporate engineering departments use spread sheets to monitor the cable tray runs for cable fill. With such a program, the cable tray fill area values for each cable tray run or section can be continuously upgraded. If a specified cable tray run or section becomes overfilled, it will be flagged for corrective action by the designer.

- Cable Installation Provisions - The cable tray system must be designed and installed, to allow access for cable installation. For many installations, the cables may be hand laid into the cable trays and

no cable pulling equipment is required. There are other installations where sufficient room must be allotted for all the cable pulling activities and equipment.

The cable manufacturers will provide installation information for their cables such as maximum pulling tension, allowable sidewall pressures, minimum bending radii, maximum permissible pulling length etc.. Lubricants are not normally used on cables being installed in cable trays.

The engineer and designers should discuss in detail the installation of the cables with the appropriate construction personnel. This will help to avoid installation problems and additional installation costs. It is important that the cable pull is in the direction that will result in the lowest tension on the cables. Keep in mind there also needs to be room at the ends of the pulls for the reel setups and for the power pulling equipment. Cable pulleys should be installed at each direction change. Triple pulleys should be used for 90 degree horizontal bends and all vertical bends. Single pulleys are adequate for horizontal bends less than 90 degrees. Use rollers in-between pulleys and every 10 to 20 feet depending on the cable weight. Plastic jacketed cables are easier to pull than are the metallic jacketed cables and there is less chance of cable damage. The pulling eye should always be attached to the conductor material to avoid tensioning the insulation. For interlocked armor cables, the conductors and the armor both have to be attached to the pulling eye.

Normally, the cables installed in cable trays are not subjected to the damage suffered by insulated conductors pulled into conduit. Depending on the size of the insulated conductors and the conduit, jamming can take place which places destructive stresses on the cable insulation. In the October, 1991 issue of ECJ&M magazine, the article on cable pulling stated that 92 percent of the insulated conductors that fail do so because they were damaged in installation.

CABLE TRAY ACCESSORIES.

B-Line manufactures a full line of prefabricated accessories for all types of B-Line cable trays. The use of the appropriate accessories will provide installation cost and time savings. In addition to providing desirable electrical and mechanical features for the cable tray system, the use of the appropriate accessories improves the physical appearance of the cable tray system. Some of the most common accessories are shown below.

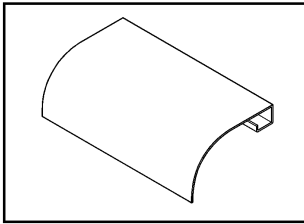

Ladder Dropout

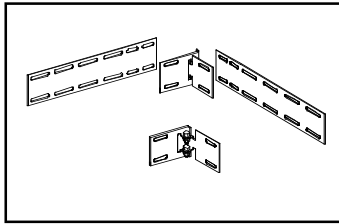

Horizontal Adjustable Splice

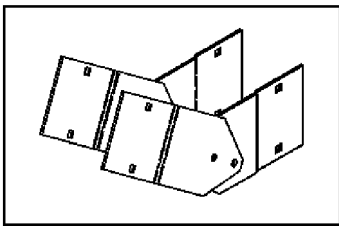

Vertical Adjustable Splice

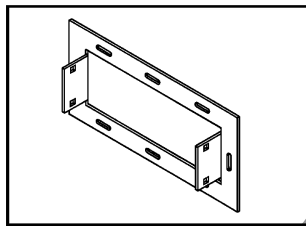

Frame Box Connector

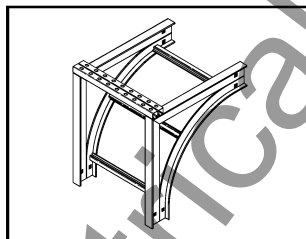

Cable Support Fitting

FIREPROOFING CABLE TRAY

Cable trays should not be encapsulated for fire protection purposes other than for the short lengths at fire rated walls unless the cables are adequately derated. Encapsulation to keep fire heat out will also keep conductor heat in. If conductors cannot dissipate their heat, their insulation systems will deteriorate. If the cable tray will be encapsulated, the cable manufacturer should be consulted for derating information.

CABLE TRAY MAINTENANCE AND REPAIR

If the cable tray finish and load capacity is properly specified and the tray is properly installed, virtually no maintenance is required.

Pre-Galvanized - This finish is for dry indoor locations. No maintenance is required.

Hot Dip Galvanized - This finish is maintenance free for many years in all but the most severe environments. If components have been cut or drilled in the field, the exposed steel area should be repaired with a cold galvanizing compound. B-Line has a spray on zinc coating available which meets the requirements of ASTM A780, *Repair of Hot Dip Finishes*.

Aluminum - Our cable tray products are manufactured from type 6063-T6 aluminum alloy with a natural finish. The natural oxide finish is self healing and requires no repair if it is field modified.

Non-metallic - Fabrication with fiberglass is relatively easy and comparable to working with wood. Any surface that has been drilled, cut, sanded, or otherwise broken, **must be sealed** with a comparable resin. Polyester or vinyl ester sealing kits are available.

Cable tray should be visually inspected each year for structural damage i.e., broken welds, bent rungs or severely deformed side rails. If damage is evident, from abuse or installation, it is recommended that the damaged section of cable tray be replaced rather than repaired. It is much easier to drop a damaged section of tray out from under the cables than it is to shield the cables from weld spatter.

CABLE TRAY. THERMAL CONTRACTION AND EXPANSION

All materials expand and contract due to temperature changes. Cable tray installations should incorporate features which provide adequate compensation for thermal contraction and expansion. Installing expansion joints in the cable tray runs only at the structure expansion joints does not normally compensate adequately for the cable tray's thermal contraction and expansion. The supporting structure material and the cable tray material will have different thermal expansion values. They each require unique solutions to control thermal expansion.

NEC® Section 300.7(B) states that '**Raceways shall be provided with expansion joints where necessary to compensate for thermal expansion or contraction.**' NEC® Section 392 does not address thermal contraction and expansion of cable tray. One document which addresses expansion is the NEMA Standards Publication No. VE 2, Section 4.3.2. NEMA VE-2 Table 4-2 shows the allowable lengths of steel and aluminum cable tray between expansion joints for the temperature differential values.

Reprinted with permission from NFPA 70-1999, the National Electrical Code®, Copyright© 1998, National Fire Protection Association, Quincy, MA 02269. This reprinted material is not the complete and official position of the National Fire Protection Association, on the referenced subject which is represented only by the standard in its entirety.

**Table 4-2
Maximum Spacing Between Expansion Joints
That Provide For One Inch (25.4 mm) Movement**

Temp. Differential		Steel		Aluminum		Stainless Steel				FRP	
°F	(°C)	Feet	(m)	Feet	(m)	304		316		Feet	(m)
25	(-4)	512	(156.0)	260	(79.2)	347	(105.7)	379	(115.5)	667	(203.3)
50	(10)	256	(78.0)	130	(39.6)	174	(53.0)	189	(57.6)	333	(101.5)
75	(24)	171	(52.1)	87	(26.5)	116	(35.4)	126	(38.4)	222	(67.6)
100	(38)	128	(39.0)	65	(19.8)	87	(26.5)	95	(29.0)	167	(50.9)
125	(51)	102	(31.1)	52	(15.8)	69	(21.0)	76	(23.2)	133	(40.5)
150	(65)	85	(25.9)	43	(13.1)	58	(17.7)	63	(19.2)	111	(33.8)
175	(79)	73	(22.2)	37	(11.3)	50	(15.2)	54	(16.4)	95	(28.9)

For a 100°F differential (winter to summer), a steel cable tray will require an expansion joint every 128 feet and an aluminum cable tray every 65 feet. The temperature at the time of installation will dictate the gap setting.

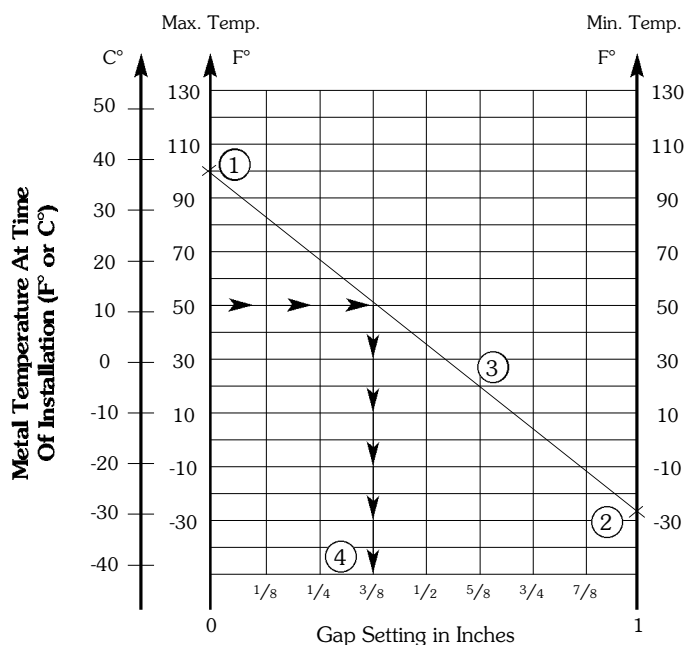

Figure 4.13B
Gap Setting Of Expansion Splice Plate
1" (25.4 mm) Gap Maximum

The Gap Setting of the Expansion Joint Splice Plate is used as follows per the example indicated in VE-2 Figure 4.13B.

Step 1. Plot the highest expected cable tray metal temperature during the year on the maximum temperature vertical axis. Example's Value: 100 Degrees F.

Step 2. Plot the lowest expected cable tray metal temperature during the year on the minimum temperature vertical axes. Example's Value: - 28 Degrees F.

Step 3. Draw a line between these maximum and minimum temperature points on the two vertical axis.

Step 4. To determine the required expansion joint gap setting at the time of the cable tray's installation: Plot the cable tray metal temperature at the time of the cable tray installation on the maximum temperature vertical axis (Example's Value: 50

Degrees F). Project over from the 50 Degrees F point on the maximum temperature vertical axis to an intersection with the line between the maximum and minimum cable tray metal temperatures. From this intersection point, project down to the gap setting horizontal axis to find the correct gap setting value (Example's Value: $\frac{3}{8}$ inch gap setting). This is the length of the gap to be set between the cable tray sections at the expansion joint.

The plotted High - Low Temperature Range in Figure 4-13B is 128° F. The 125° F line in Table 4-1 shows that installations in these temperature ranges would require $\frac{3}{8}$ " expansion joints approximately every 102 feet for Steel and every 52 feet for Aluminum cable tray.

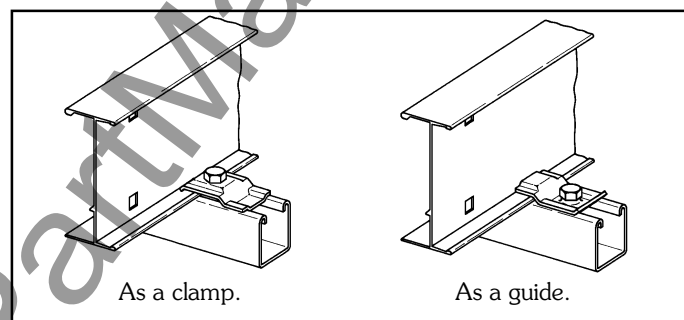

Another item essential to the operation of the cable tray expansion splices is the type of hold down clamps used. The cable tray must not be clamped to each support so firmly that the cable tray cannot contract and expand without distortion. The cable tray needs to be anchored at the support closest to the midpoint between the expansion joints with **hold down clamps** and secured by **expansion guides** at all other support locations. The expansion guides allow the cable tray to slide back and forth as it contracts and expands. Supports must also be located on both sides of an expansion splice. The supports should be located within two feet of the expansion splice to ensure that the splice will operate properly. If these guidelines for cable tray thermal contraction and expansion are not followed, there is the potential for the cable trays to tear loose from their supports, and for the cable trays to bend and collapse.

www.ElectricalPartManuals.com

Appendix Pages

Appendix Sheet 1	45
Temperature Rise Tests, Cable Tray Connectors, Class II Aluminum & Steel Ladder Tray	
Appendix Sheet 2	46
Temperature Rise Tests, Conduit Clamps For Bonding Rigid Conduit To Cable Tray	
Appendix Sheet 3	47
Example - NEC [®] Section 392.9(A)(1)	
Appendix Sheet 4	48
Example - NEC [®] Section 392.9(A)(2)	
Appendix Sheet 5	49
Example - NEC [®] Section 392.9(A)(3)	
Appendix Sheet 6	50
Example - NEC [®] Section 392.9(B)	
Appendix Sheet 7	51
Table 250.122 Minimum Size EGC for Raceway and Equipment	
Appendix Sheet 8	52 - 53
Cable Tray Sizing Flowchart	
Appendix Sheet 9	54 - 55
Cable Tray Installation & Specification Checklist	
Appendix Sheet 10	56
Additional Cable Tray Resources and Engineering Software	
Appendix Sheet 11	57
B-Line Wire Management Resources	

**TABLE I
TEMPERATURE RISE TESTS, CABLE TRAY CONNECTORS,
CLASS II ALUMINUM LADDER CABLE TRAY**

Test Current Amps And Fuse Size*	Test Time Cycles	I ² T mult. by 10 ⁶	Connector Data								
			C1			C2			C3		
			Type Of Connector	No. & Type Bolts	Temp. Rise °C	Type Of Connector	No. & Type Bolts	Temp. Rise °C	Type Of Connector	No. & Type Bolts	Temp. Rise °C
7,900 1,200A Fuse	66	69	Adj. Vert. 1 Bolt**	4 Steel	6	3/0 CU Bond	AL-CU Lugs	18	Rigid Clean	2 Steel	8
7,900 1,200A Fuse	82	85	Rigid Corroded	4 Steel	10	3/0 CU Bond	AL-CU Lugs	22	Rigid Clean	2 Steel	9
12,000	120	288	Rigid Corroded	2 Nylon	50	3/0 CU Bond	AL-CU Lugs	104	Rigid Clean	2 Steel	32
12,000	124	297	Rigid Corroded	4 Steel	40	Rigid Corroded	4 Lugs	46	Rigid Clean	4 Steel	21
34,600	14	280	Rigid Corroded	2 Nylon	34	3/0 CU Bond	AL-CU Lugs	75	Rigid Clean	2 Steel	29
34,400	14	276	Rigid Corroded	4 Nylon	28	Rigid Corroded	4 Steel	35	Rigid Clean	4 Steel	20

**TABLE II
TEMPERATURE RISE TESTS, CABLE TRAY CONNECTORS,
CLASS II STEEL LADDER CABLE TRAY**

Test Current Amps And Fuse Size*	Test Time Cycles	I ² T mult. by 10 ⁶	Connector Data								
			C1			C2			C3		
			Type Of Connector	No. & Type Bolts	Temp. Rise °C	Type Of Connector	No. & Type Bolts	Temp. Rise °C	Type Of Connector	No. & Type Bolts	Temp. Rise °C
1,980 200A, FU	52	3.4	Adj. Vert. 1 Bolt**	4	2	No. 6 CU Bond	AL-CU Lugs	10	Rigid	2	3
1,970 400A, FU	394	25.5	Adj. Vert. 1 Bolt**	4	9	No. 6 CU Bond	AL-CU Lugs	***	Rigid	2	15
1,960 400A, FU	8100	51.8	Adj. Vert. 1 Bolt**	4	18	Rigid	4	23	Rigid	2	32
12,000	120	288	Adj. Vert. 2 Bolts**	4	94	Adj. Vert. 2 Bolts**	4	89	Rigid	4	81
12,000	123	295	Rigid	4	70	Rigid	4	87	Rigid	4	85
34,000	13	250	Rigid	4	71	Rigid	4	57	Rigid	4	69

* Test current was interrupted in a predetermined time when a fuse was not used.

** 1 or 2 Bolts - Number of bolts installed on the adjustable vertical connector hinge.

*** The No. 6 bonding jumper melted and opened the circuit when protected by 400A fuse.

(See Page 29 - Figure 1 for Temperature Rise Test illustration)

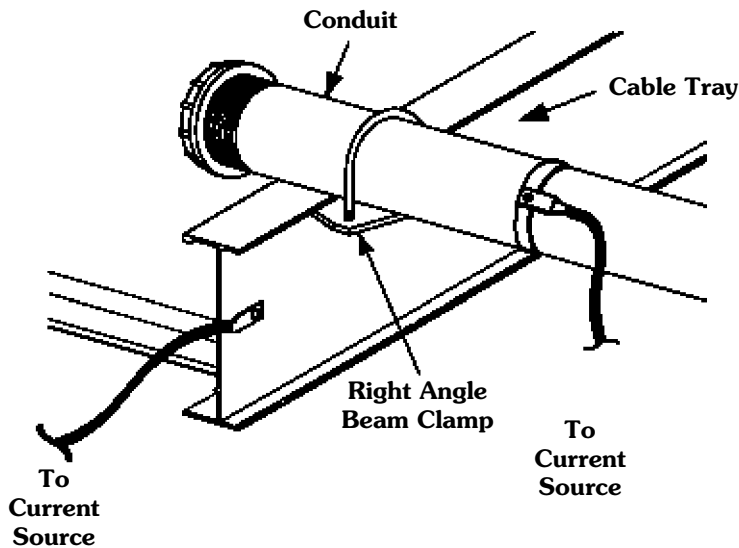

Test Set-Up

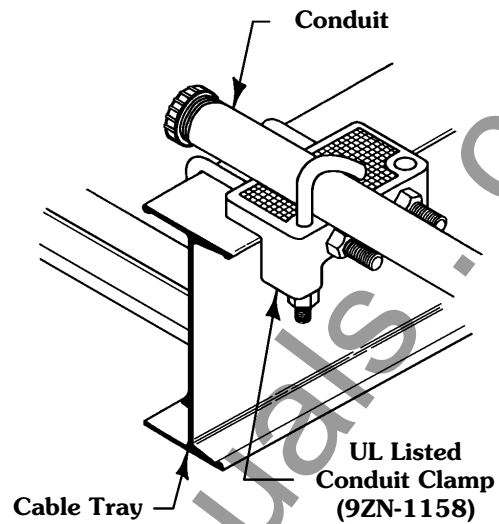

Conduit Clamp Detail

CIRCUIT ARRANGEMENT FOR RIGID CONDUIT TEMPERATURE RISE TESTS

**TABLE III
TEMPERATURE RISE TESTS, CONDUIT CLAMPS
FOR BONDING RIGID CONDUIT TO CABLE TRAY**

Test Current Amperes	Test Time Cycles	I ² T mult. 10 ⁶	Rigid Conduit		Cable Tray		Temp. Rise °C	Condition After Test
			Size	Material	Class	Material		
36,000	16	344.7	4"	Aluminum	II	Aluminum	19	No arcing or damage
20,900	60.5	441.2	4"	Aluminum	II	Aluminum	70	No arcing or damage
12,100	178	433.3	4"	Aluminum	II	Aluminum	74	No arcing or damage
21,000	20	146.8	4"	Steel	II	Steel	(?)	Zinc melted at point where conduit contacted with tray
3,260	900	159.5	4"	Steel	II	Steel	63	No arcing or damage
21,000	30	220	2"	Aluminum	II	Aluminum	21	No arcing or damage
12,100	120.5	294.2	2"	Aluminum	II	Aluminum	59	No arcing or damage
8,000	245	261.1	2"	Aluminum	II	Aluminum	44	No arcing or damage
21,000	14	103.8	2"	Steel	II	Steel	62	Zinc melted at point where conduit contacted with tray
12,000	60.5	145.4	2"	Steel	II	Steel	22	Slight arc between clamp and tray
3,240	600	104.9	2"	Steel	II	Steel	49	No arcing or damage
21,000	20	146.8	1"	Aluminum	II	Aluminum	20	No arcing or damage
12,200	60.5	150.3	1"	Aluminum	II	Aluminum	24	No arcing or damage
12,100	14.5	35.3	1"	Steel	II	Steel	6	No arcing or damage
8,000	63.5	67.84	1"	Steel	II	Steel	59	No arcing or damage
1,980 200A FU	44.5	2.9	1"	Steel	II	Steel	1	No arcing or damage

Example - NEC® Section 392.9(A)(1)

Width selection for cable tray containing 600 volt multiconductor cables, sizes #4/0 AWG and larger only. Cable installation is limited to a single layer. The sum of the cable diameters (Sd) must be equal to or less than the usable cable tray width.

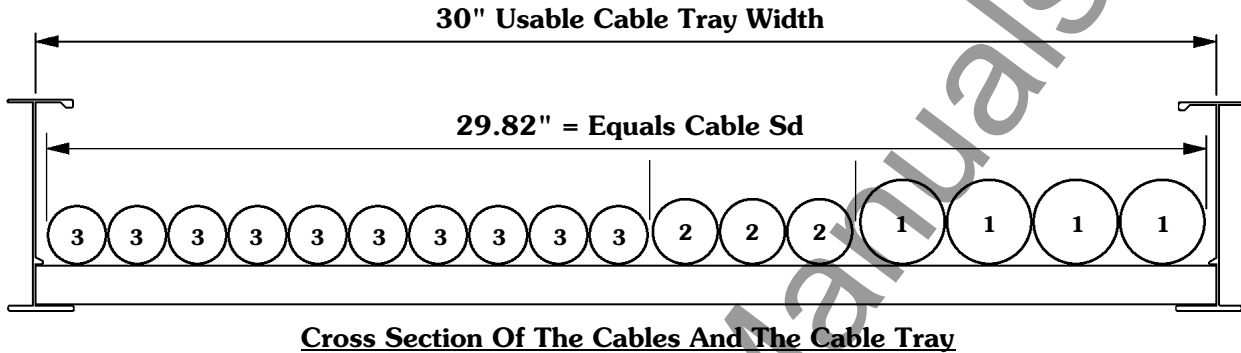

Cable tray width is obtained as follows:

Item Number	List Cable Sizes	(D) List Cable Outside Diameter	(N) List Number of Cables	Multiply (D) x (N) Subtotal of the Sum of the Cables Diameters (Sd)
1.	3/C - #500 kcmil	2.26 inches	4	9.04 inches
2.	3/C - #250 kcmil	1.76 inches	3	5.28 inches
3.	3/C - #4/0 AWG	1.55 inches	10	15.50 inches

The sum of the diameters (Sd) of all cables (Add Sds for items 1, 2, & 3.)

$$9.04 \text{ inches} + 5.28 \text{ inches} + 15.50 \text{ inches} = 29.82 \text{ inches (Sd)}$$

A cable tray with a usable width of 30 inches is required. For a 10% increase in cost a 36 inch wide cable tray could be purchased which would provide for some future cable additions.

Notes:

- The cable sizes used in this example are a random selection.
- Cables - copper conductors with cross linked polyethylene insulation and a PVC jacket. (These cables could be ordered with or without an equipment grounding conductor.)
- Total cable weight per foot for this installation.
61.4 lbs./ft. (without equipment grounding conductors)
69.9 lbs./ft. (with equipment grounding conductors)
This load can be supported by a load symbol "B" cable tray - 75 lbs./ft.

Example - NEC® Section 392.9(A)(2)

Width selection for cable tray containing 600 volt multiconductor cables, sizes #3/0 AWG and smaller. Cable tray allowable fill areas are listed in Column 1 of Table 392.9.

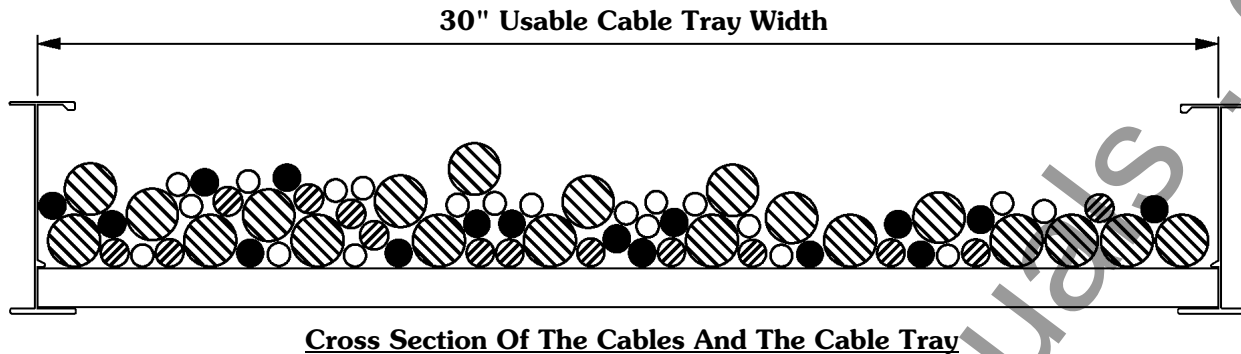

Cable tray width is obtained as follows:

Item Number	List Cable Sizes	(A) List Cable Cross Sectional Areas	(N) List Number of Cables	Multiply (A) x (N) Total of the Cross Sectional Area for Each Item
1.	3/C #12 AWG	0.17 sq. in.	20	3.40 sq. in.
2.	4/C #12 AWG	0.19 sq. in.	16	3.04 sq. in.
3.	3/C #6 AWG	0.43 sq. in.	14	6.02 sq. in.
4.	3/C #2 AWG	0.80 sq. in.	20	16.00 sq. in.

Method 1.

The sum of the total areas for items 1, 2, 3, & 4:

$$3.40 \text{ sq. in.} + 3.04 \text{ sq. in.} + 6.02 \text{ sq. in.} + 16.00 \text{ sq. in.} = 28.46 \text{ sq. inches}$$

From Table 392.9 Column 1 a 30 inch wide tray with an allowable fill area of 35 sq. in. must be used. The 30 inch cable tray has the capacity for additional future cables (6.54 sq. in. additional allowable fill area can be used.)

Method 2.

The sum of the total areas for items 1, 2, 3, & 4 multiplied by

$$\left(\frac{6 \text{ in.}}{7 \text{ sq. in.}} \right) = \text{cable tray width required}$$

$$3.40 \text{ sq. in.} + 3.04 \text{ sq. in.} + 6.02 \text{ sq. in.} + 16.00 \text{ sq. in.} = 28.46 \text{ sq. in.}$$

$$\left(\frac{28.46 \text{ sq. in.} \times 6 \text{ in.}}{7 \text{ sq. in.}} \right) = 24.39 \text{ inch cable tray width required}$$

Use a 30 inch wide cable tray.

Notes:

- The cable sizes used in this example are a random selection.
- Cables - copper conductors with cross linked polyethylene insulation and a PVC jacket. (These cables could be ordered with or without an equipment grounding conductor.)
- Total cable weight per foot for this installation.
31.9 lbs./ft. (Cables in this example do not contain equipment grounding conductors.)
This load can be supported by a load symbol "A" cable tray - 50 lbs./ft.

Example - NEC® Section 392.9(A)(3)

Width selection for cable tray containing 600 volt multiconductor cables, sizes #4/0 AWG and larger (single layer required) and #3/0 AWG and smaller. These two groups of cables must have dedicated areas in the cable tray.

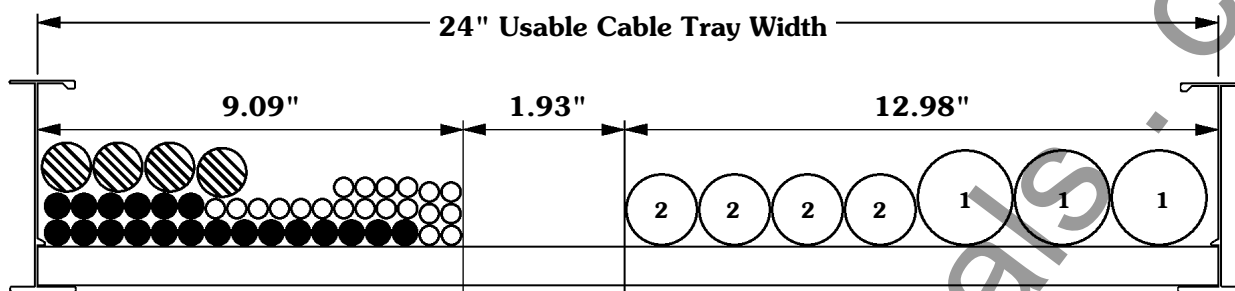

Cross Section Of The Cables And The Cable Tray

Cable tray width is obtained as follows:

A - Width required for #4/0 AWG and larger multiconductor cables -

Item Number	List Cable Sizes	(D) List Cable Outside Diameter	(N) List Number of Cables	Multiply (D) x (N) Subtotal of the Sum of the Cables Diameters (Sd)
1.	3/C - #500 kcmil	2.26 inches	3	6.78 inches
2.	3/C - #4/0 AWG	1.55 inches	4	6.20 inches

Total cable tray width required for items 1 & 2 = 6.78 inches + 6.20 inches = 12.98 inches

B - Width required for #3/0 AWG and smaller multiconductor cables -

Item Number	List Cable Sizes	(A) List Cable Cross Sectional Area	(N) List Number of Cables	Multiply (A) x (N) Total of the Cross Sectional Area For Each Item
3.	3/C #12 AWG	0.17 sq. in.	20	3.40 sq. in.
4.	3/C #10 AWG	0.20 sq. in.	20	4.00 sq. in.
5.	3/C #2 AWG	0.80 sq. in.	4	3.20 sq. in.

Total cable tray width required for items 3, 4, & 5

$$(3.40 \text{ sq. in.} + 4.00 \text{ sq. in.} + 3.20 \text{ sq. in.}) \left(\frac{6 \text{ in.}}{7 \text{ sq. in.}} \right)^1 = (10.6 \text{ sq. in.}) \left(\frac{6 \text{ in.}}{7 \text{ sq. in.}} \right)^1 = 9.09 \text{ inches}$$

Actual cable tray width is A - Width (12.98 in.) + B - Width (9.09 in.) = 22.07 inches

A 24 inch wide cable tray is required. The 24 inch cable tray has the capacity for additional future cables (1.93 inches or 2.25 sq. inches allowable fill can be used).

Notes:

1. This ratio is the inside width of the cable tray in inches divided by its maximum fill area in sq. inches from Column 1 Table 392.9.
2. The cable sizes used in this example are a random selection.
3. Cables - copper conductors with cross linked polyethylene insulation and a PVC jacket.
4. Total cable weight per foot for this installation.
40.2 lbs./ft. (Cables in this example do not contain equipment grounding conductors.)

Example - NEC® Section 392.9(B)

Cable Tray containing Type ITC or Type PLTC Cables

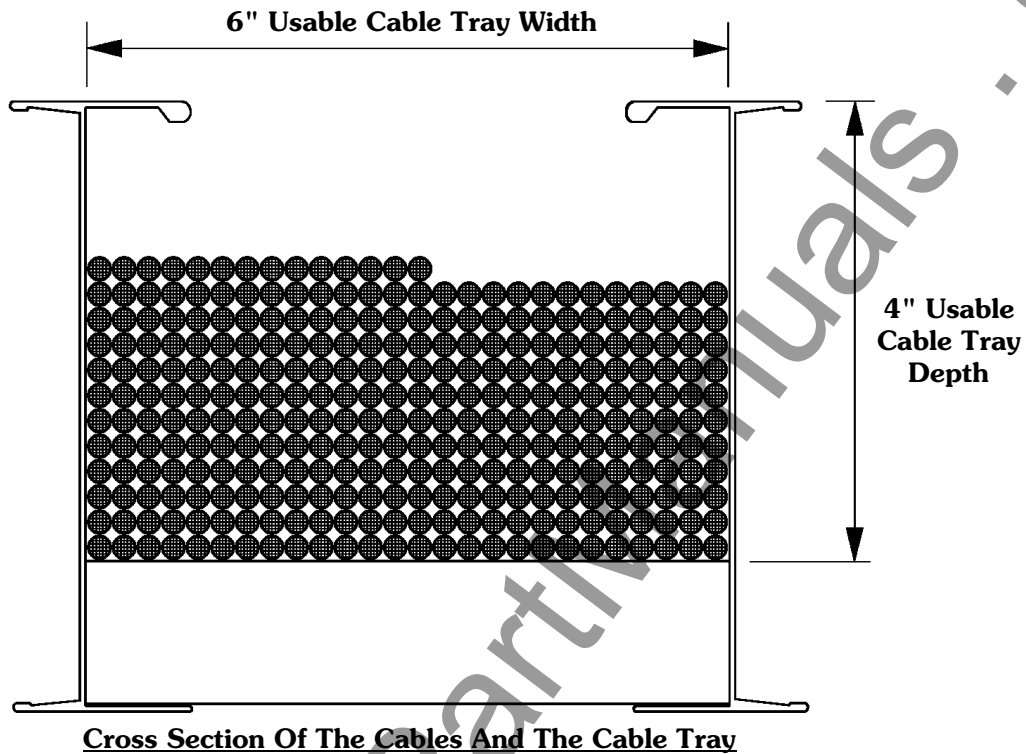

50% of the cable tray useable cross sectional area can contain type PLTC cables

4 inches x 6 inches x .050 = 12 square inches allowable fill area.

2/C - #16 AWG 300 volt shielded instrumentation cable O.D. = 0.224 inches.

Cross Sectional Area = 0.04 square inches.

$$\frac{12 \text{ sq. in.}}{0.04 \text{ sq. in./cable}} = 300 \text{ cables can be installed in this cable tray.}$$

$$\frac{300 \text{ cables}}{26 \text{ cables/rows}} = 11.54 \text{ rows can be installed in this cable tray.}$$

Notes:

1. The cable sizes used in this example are a random selection.
2. Cables - copper conductors with PVC insulation, aluminum/mylar shielding, and PVC jacket.

Table 250.122. Minimum Size Equipment Grounding Conductors for Grounding Raceways and Equipment

Rating or Setting of Automatic Overcurrent Device in Circuit Ahead of Equipment, Conduit, etc., Not Exceeding (Amperes)	Size (AWG or kcmil)	
	Copper	Aluminum or Copper-Clad Aluminum*
15	14	12
20	12	10
30	10	8
40	10	8
60	10	8
100	8	6
200	6	4
300	4	2
400	3	1
500	2	1/0
600	1	2/0
800	1/0	3/0
1000	2/0	4/0
1200	3/0	250
1600	4/0	350
2000	250	400
2500	350	600
3000	400	600
4000	500	800
5000	700	1200
6000	800	1200

Reprinted with permission from NFPA 70-1999, the National Electrical Code®, Copyright© 1998, National Fire Protection Association, Quincy, MA 02269. This reprinted material is not the complete and official position of the National Fire Protection Association, on the referenced subject which is represented only by the standard in its entirety.

CABLE TRAY SIZING FLOWCHART

Sizing Cable Tray Per NEC 392

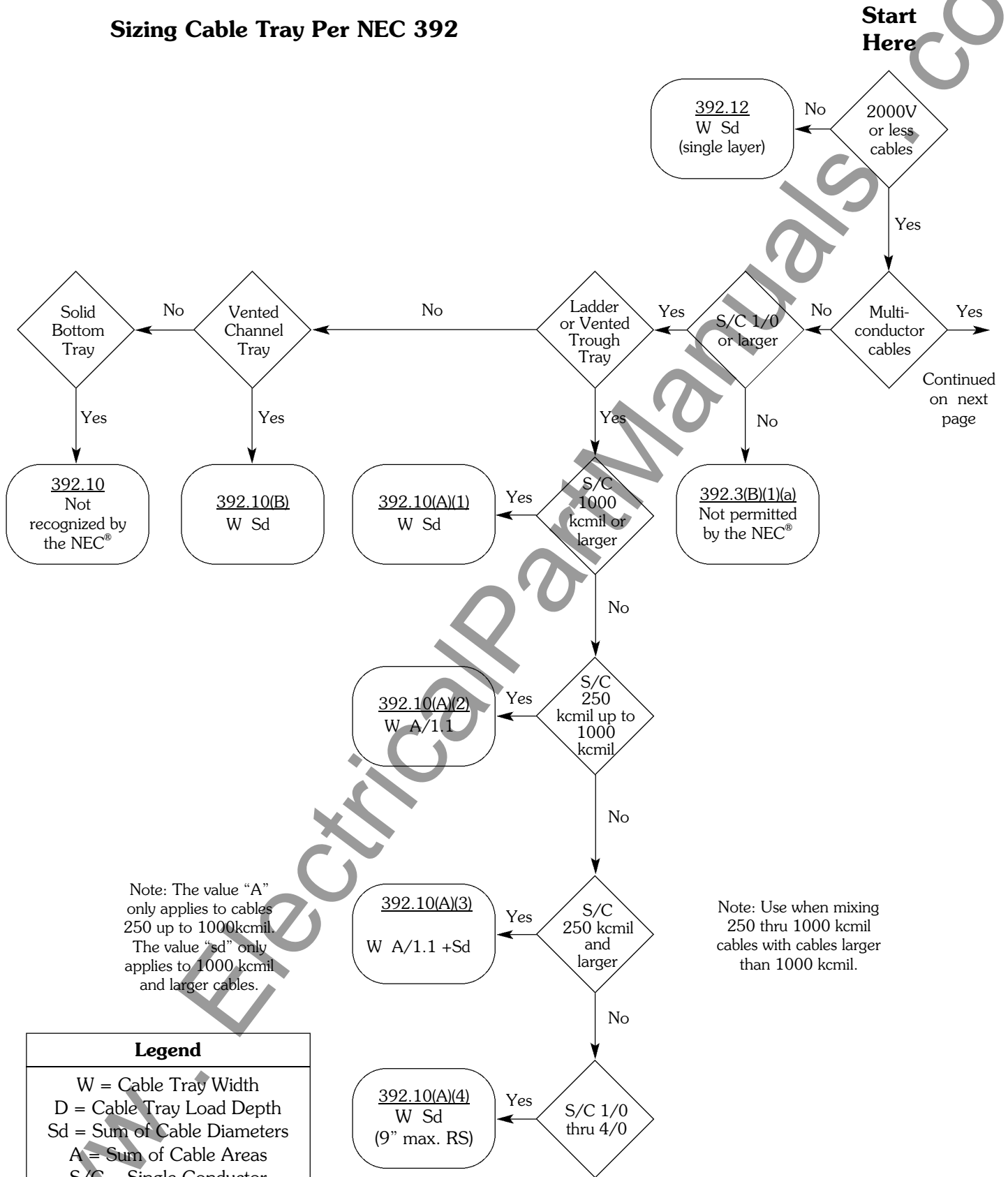

Note: The value "A" only applies to cables 250 up to 1000kcmil. The value "sd" only applies to 1000 kcmil and larger cables.

Note: Use when mixing 250 thru 1000 kcmil cables with cables larger than 1000 kcmil.

Legend
W = Cable Tray Width
D = Cable Tray Load Depth
Sd = Sum of Cable Diameters
A = Sum of Cable Areas
S/C = Single Conductor
M/C = Multiconductor Cables
RS = Ladder Rung Spacing

CABLE TRAY SIZING FLOWCHART

Ampacity: See pages 36 - 38 for information on cable ampacity that might affect the cable tray sizing flowchart.

See pages 15 - 17 for information on hazardous (classified) areas that might affect the cable tray sizing flowchart.

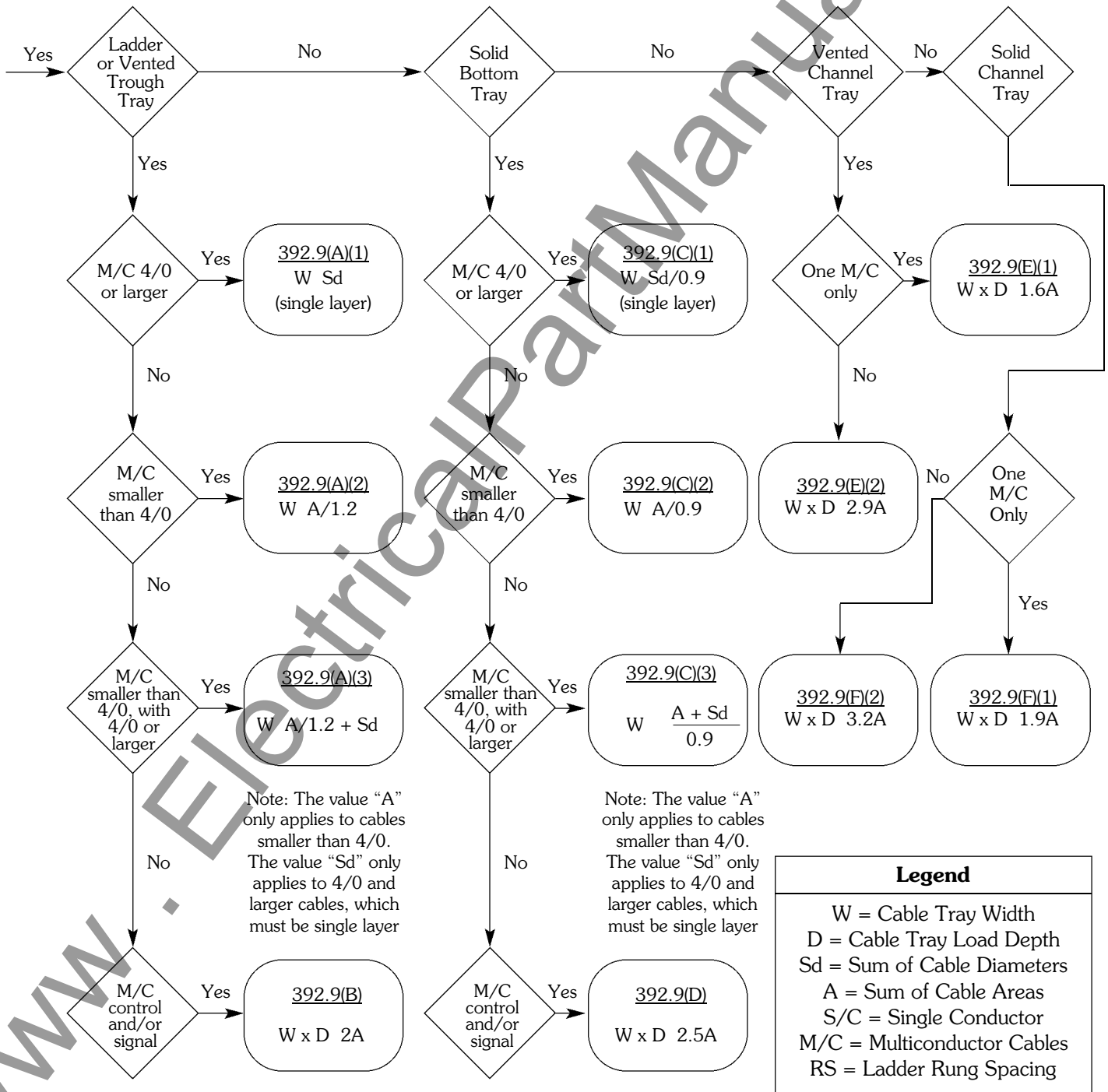

CABLE TRAY INSTALLATION & SPECIFICATION CHECKLIST

Project Information

Project Name: _____ # _____
 Location: _____
 Contractor/Engineer: _____
 Phone: _____

Project Information

Distributor Name: _____
 Location: _____
 Contact: _____
 Phone: _____ Fax: _____

Cable Tray

<u>Material</u>		<u>NEMA Load Depth*</u>	
Aluminum	<input type="checkbox"/>	2" **	<input type="checkbox"/>
Pre-Galvanized Steel	<input type="checkbox"/>	3"	<input type="checkbox"/>
Hot-Dip Galvanized Steel	<input type="checkbox"/>	4"	<input type="checkbox"/>
304 Stainless Steel	<input type="checkbox"/>	5"	<input type="checkbox"/>
316 Stainless Steel	<input type="checkbox"/>	6"	<input type="checkbox"/>
Fiberglass-Polyester Resin	<input type="checkbox"/>		
Fiberglass-Vinyl Ester Resin	<input type="checkbox"/>		

* Load depth is 1" less than siderail height.
 ** Fiberglass and wire mesh.

<u>Width</u>		<u>Bottom Styles</u>		<u>Length</u>		<u>Fitting Radius</u>
6" <input type="checkbox"/>		6" <input type="checkbox"/>		<u>Metallic</u>		12" <input type="checkbox"/>
9" <input type="checkbox"/>		9" <input type="checkbox"/>		120" <input type="checkbox"/>		24" <input type="checkbox"/>
12" <input type="checkbox"/>		12" <input type="checkbox"/>		144" <input type="checkbox"/>		36" <input type="checkbox"/>
18" <input type="checkbox"/>		18" <input type="checkbox"/>		240" <input type="checkbox"/>		48" <input type="checkbox"/>
24" <input type="checkbox"/>		Ventilated Trough <input type="checkbox"/>		288" <input type="checkbox"/>		
30" <input type="checkbox"/>		Solid Trough <input type="checkbox"/>		<u>Non-Metallic</u>		
36" <input type="checkbox"/>		Solid Bottom <input type="checkbox"/>		120" <input type="checkbox"/>		
42" <input type="checkbox"/>				240" <input type="checkbox"/>		

Tray Series

B-Line Series _____

OR

NEMA Class

A (50 lbs./ft.)

B (75 lbs./ft.)

C (100 lbs./ft.)

Support Span _____ ft.

Load Rating _____ lbs./ft.

Safety Factor _____

CABLE TRAY INSTALLATION & SPECIFICATION CHECKLIST

Cable Channel

<u>Material</u>		<u>Width</u>	
Aluminum	<input type="checkbox"/>	3"	<input type="checkbox"/>
Pre-Galvanized Steel	<input type="checkbox"/>	4"	<input type="checkbox"/>
Hot-Dip Galvanized Steel	<input type="checkbox"/>	6"	<input type="checkbox"/>
304 Stainless Steel	<input type="checkbox"/>	8" *	<input type="checkbox"/>
316 Stainless Steel	<input type="checkbox"/>		
Fiberglass-Polyester Resin	<input type="checkbox"/>		* Fiberglass only.
Fiberglass-Vinyl Ester Resin	<input type="checkbox"/>		
<u>Type</u>		<u>Fitting Radius</u>	
Ventilated	<input type="checkbox"/>	0"	<input type="checkbox"/>
Non-Ventilated	<input type="checkbox"/>	6"	<input type="checkbox"/>
		12"	<input type="checkbox"/>
		24"	<input type="checkbox"/>
		36"	<input type="checkbox"/>

Cent-R-Rail

<u>System</u>		<u>Depth*</u>	
Data-Track	<input type="checkbox"/>	Straight Rung	<input type="checkbox"/>
Verti-Rack	<input type="checkbox"/>	2"	<input type="checkbox"/>
Half-Rack	<input type="checkbox"/>	3"	<input type="checkbox"/>
Multi-Tier Half Rack	<input type="checkbox"/>	4"	<input type="checkbox"/>
		6"	<input type="checkbox"/>
<u>Width*</u>	<u>Rung Spacing*</u>	<u>Tiers*</u>	<u>Length</u>
3" <input type="checkbox"/>	6" <input type="checkbox"/>	2 <input type="checkbox"/>	120" <input type="checkbox"/>
6" <input type="checkbox"/>	9" <input type="checkbox"/>	3 <input type="checkbox"/>	144" <input type="checkbox"/>
9" <input type="checkbox"/>	12" <input type="checkbox"/>	4 <input type="checkbox"/>	
12" <input type="checkbox"/>	18" <input type="checkbox"/>	5 <input type="checkbox"/>	
18" <input type="checkbox"/>	24" <input type="checkbox"/>	6 <input type="checkbox"/>	
24" <input type="checkbox"/>			

* Options shown are not available for all systems. Please check B-Line Cent-R-Rail Catalog for availability.

Wire Basket Tray

<u>Width*</u>	<u>Depth*</u>	<u>Wire Mesh Size</u>	<u>Length</u>
2" <input type="checkbox"/>	1" <input type="checkbox"/>	2 x 4	118" (3 meters)
4" <input type="checkbox"/>	2" <input type="checkbox"/>		
6" <input type="checkbox"/>	4" <input type="checkbox"/>		
8" <input type="checkbox"/>			
12" <input type="checkbox"/>			
18" <input type="checkbox"/>			
24" <input type="checkbox"/>			

* Widths shown are not available for all depths.
Please check B-Line Wire Basket Catalog for availability.

Footnotes:

¹ NEMA Standard VE-2, Section 4, Installation 4.3 Straight Section Installation - 4.3.1. Horizontal Cable Tray Straight Sections states that straight section lengths should be equal to or greater than the span length to ensure not more than one splice between supports.

Additional Cable Tray Resources

Cable Tray Institute
1300 N. 17th Street
Rosslyn, VA 22209
www.cabletrays.com

National Electrical Manufacturers Association
1300 N. 17th Street
Rosslyn, VA 22209
www.nema.org

B-Line Engineering Software

TrayCAD®

TrayCAD® is a Cable Tray layout design program that works within the AutoCAD® environment. TrayCAD® is a windows based program and installs as an add-on to your AutoCAD® system. Use the TrayCAD® toolbar to add cable tray to your existing plans by drawing a single centerline representation of the tray run. Then, with the click of a button, the program will build a full-scale 3-D wire-frame model of the cable tray and all the appropriate fittings. The program also automatically creates a Bill of Material and contains a library of modifiable details.

Runway Router®

Runway Router® is a cable ladder runway (ladder rack) layout design program that works within your AutoCAD® environment. Use the commands from the Runway Router® toolbar to layout runway, relay racks and electronic cabinets. Add cable tray or Cent-R-Rail® to your existing plans by drawing a single centerline representation of the cable run. Then, with the click of a button, the program will build a full-scale 3-D wire-frame model of the cable runway and all the appropriate connectors and fittings. The program also automatically creates a Bill of Material and contains a library of modifiable details.

B-Line Wire Management Resources

B-Line Product Catalogs

- Cable Tray Systems (CT-02)
Metallic, Two Siderail System
Commercial and Industrial Applications
- Fiberglass Cable Tray (CT03FRP)
Non-Metallic, Two Siderail Trays
Non-Metallic Strut Systems
- Cent-R-Rail® (CR-03)
Center Supported Cable Tray
“Lay-In” Cable Design for Easy Installation
of Low Voltage Cables
- Redi-Rail® (RR-03)
Pre-Punched Aluminum Side Rail Design
Unmatched Job Site Adaptability for a Two
Side Rail System - Load Depths 2” to 6”
- Wire Basket Runway (WB-05)
Unmatched Adaptability to Site Conditions
Pre-Packaged Installation Kits and Accessories
Fast - Adaptable - Economical

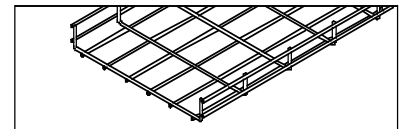
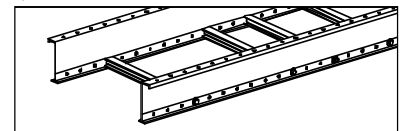
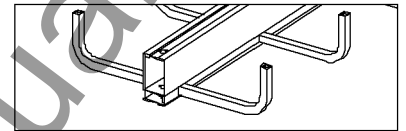
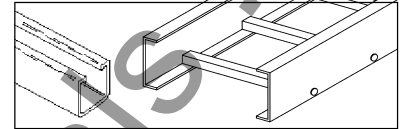
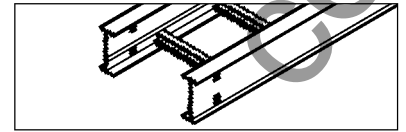

Other B-Line Wire Management Systems

- Telecom (BLCOMD-03)
Saunders' Cable Runway and Relay Racks
Unequal Flange Racks
- Cable Hooks (BLF-03)
Supports all Cat 5, Fiber Optic, Innerduct
and Low Voltage Cabling Requirements
- Wireway (ENC-02R)
Houses Runs of Control and Power Cable
Available in NEMA 12, Type 1 & Type 3R

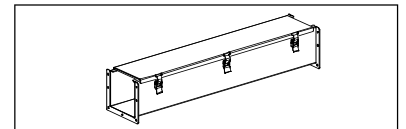
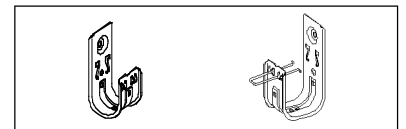
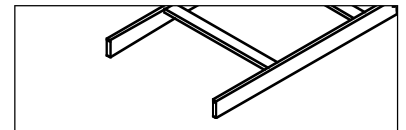

B-Line Mechanical Support Systems

- Strut Systems (SS-00R2)
Metal Framing Support System. Fully Adjustable
and Reusable, with a Complete Line of Channel,
Fittings and Accessories for Multi-Purpose Applications
- Seismic Restraints (SRS-02)
Multi-Directional Bracing for Electrical Conduit,
Cable Tray and Mechanical Piping Systems.
OSHDP Pre-Approved Details

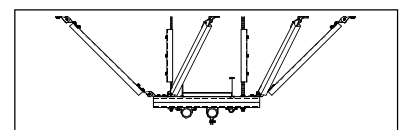
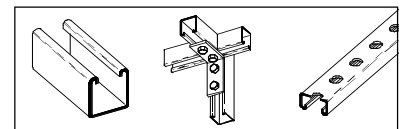

Ask the Experts



Cent-R-Rail



Redi-Rail



Wire Basket



Metalic
Cable Tray



Non-Metalic
Cable Tray



Cooper B-Line, Inc
509 W. Monroe Street
Highland, IL 62249
Phone: 800-851-7415
Fax: 618-654-1917

www.cooperbline.com

COOPER B-Line