

Engineering Dependable Protection

Engineering Dependable Protection - Part I "A Simple Approach to Short-Circuit Calculations"

Table of Contents	Page
Basic Considerations of Short-Circuit Calculations	3
- Why Short-Circuit Calculations	3
- General Comments on Short-Circuit Calculations	3
- Asymmetrical Components	3
- Interrupting Rating, Interrupting Capacity, Short-Circuit Currents	4
3 \emptyset Short-Circuit Current Calculations, Procedures and Methods	5
- Ohmic Method	6
- Per-Unit Method	11
- TRON [®] Computer Software Procedure	16
- Point-to-Point Method	17
- Comparison of Results	19
1 \emptyset Short-Circuit Calculation on 1 \emptyset Transformer System, Procedures and Methods	20
- Per-Unit Method - Line-to-Line Faults	21
- Per-Unit Method - Line-to-Neutral Faults	22
- Point-to-Point Method - Line-to-Line Faults	23
- Point-to-Point Method - Line-to-Neutral Faults	24
- Comparison of Results	24
Data Section	25
- Table 1 - Transformer Impedance Data	25
- Table 2 - Current Transformer Reactance Data	25
- Table 3 - Disconnecting Switch Reactance Data	25
- Table 4 - Circuit Breaker Reactance Data	26
- Table 5 - Insulated Conductors Impedance Data	26
- Table 6 - "C" Values for PTP Method Data	27
- Table 7 - Busway Impedance Data	28
- Table 8 - Asymmetrical Factors	29
Selective Coordination - EDP II	29
Selective Protection - EDP III	29

**Part 1
A Simple Approach
To
Short Circuit
Calculations**

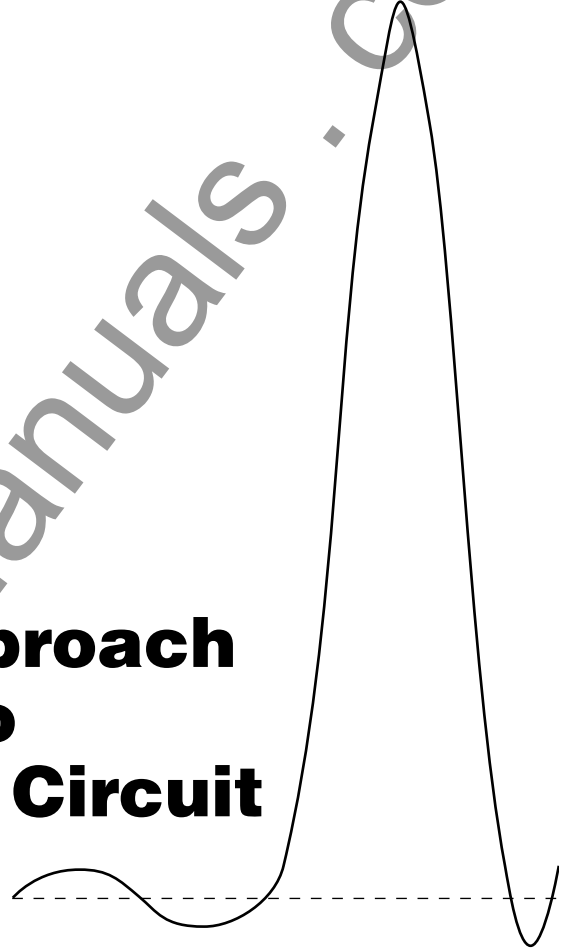

COOPER

Bussmann

Basic Considerations of Short-Circuit Calculations

Why Short-Circuit Calculations

Several sections of the National Electrical Code relate to proper overcurrent protection. Safe and reliable application of overcurrent protective devices based on these sections mandate that a short circuit study and a selective coordination study be conducted.

These sections include, among others:

- 110-9 Interrupting Rating
- 110-10 Component Protection
- 230-65 Service Entrance Equipment
- 240-1 Conductor Protection
- 250-95 Equipment Grounding Conductor Protection
- 517-17 Health Care Facilities - Selective Coordination

Compliance with these code sections can best be accomplished by conducting a short circuit study and a selective coordination study.

The protection for an electrical system should not only be safe under all service conditions but, to insure continuity of service, it should be selectively coordinated as well. A coordinated system is one where only the faulted circuit is isolated without disturbing any other part of the system. Overcurrent protection devices should also provide short-circuit as well as overload protection for system components, such as bus, wire, motor controllers, etc.

To obtain reliable, coordinated operation and assure that system components are protected from damage, it is necessary to first calculate the available fault current at various critical points in the electrical system.

Once the short-circuit levels are determined, the engineer can specify proper interrupting rating requirements, selectively coordinate the system and provide component protection.

General Comments on Short-Circuit Calculations

Short Circuit Calculations should be done at all critical points in the system.

These would include:

- Service Entrance
- Panel Boards
- Motor Control Centers
- Motor Starters
- Transfer Switches
- Load Centers

Normally, short circuit studies involve calculating a bolted 3-phase fault condition. This can be characterized as all three phases "bolted" together to create a zero impedance connection. This establishes a "worst case" condition, that results in maximum thermal and mechanical stress in the system. From this calculation, other types of fault conditions can be obtained.

Sources of short circuit current that are normally taken under consideration include:

- Utility Generation
- Local Generation
- Synchronous Motors and
- Induction Motors

Capacitor discharge currents can normally be neglected due to their short time duration. Certain IEEE (Institute of Electrical and Electronic Engineers) publications detail how to calculate these currents if they are substantial.

Asymmetrical Components

Short circuit current normally takes on an asymmetrical characteristic during the first few cycles of duration. That is, it is offset about the zero axis, as indicated in Figure 1.

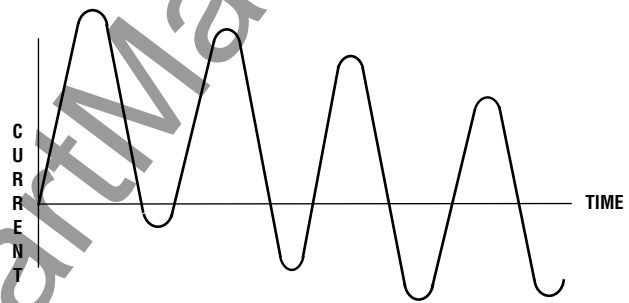

Figure 1

In Figure 2, note that the total short circuit current I_a is the summation of two components - the symmetrical RMS current I_s , and the DC component, I_{DC} . The DC component is a function of the stored energy within the system at the initiation of the short circuit. It decays to zero after a few cycles due to I^2R losses in the system, at which point the short circuit current is symmetrical about the zero axis. The RMS value of the symmetrical component may be determined using Ohm's Law. To determine the asymmetrical component, it is necessary to know the X/R ratio of the system. To obtain the X/R ratio, the total resistance and total reactance of the circuit to the point of fault must be determined. Maximum thermal and mechanical stress on the equipment occurs during these first few cycles. It is important to concentrate on what happens during the first half cycle after the initiation of the fault.

Basic Considerations of Short-Circuit Calculations

To accomplish this, study Figure 2, and refer to Table 8.

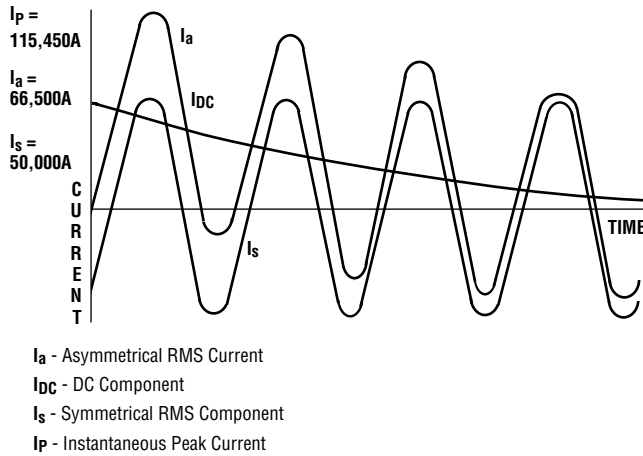

Figure 2

Figure 2 illustrates a worst case waveform that 1 phase of the 3 phase system will assume during the first few cycles after the fault initiation.

For this example, assume an RMS symmetrical short circuit value of 50,000 amperes, at a 15% short circuit power factor. Locate the 15% P.F. in Table 8. Said another way, the X/R short circuit ratio of this circuit is 6.5912.

The key portions are:

- Symmetrical RMS Short Circuit Current = I_s
- Instantaneous Peak Current = I_p
- Asymmetrical RMS Short Circuit Current (worst case single phase) = I_a

From Table 8, note the following relationships.

$$I_s = \text{Symmetrical RMS Current}$$

$$I_p = I_s \times M_p \text{ (Column 3)}$$

$$I_a = I_s \times M_m \text{ (Column 4)}$$

For this example, Figure 2,

$$I_s = 50,000 \text{ Amperes RMS Symmetrical}$$

$$I_p = 50,000 \times 2.309 \text{ (Column 3)}$$

$$= 115,450 \text{ Amperes}$$

$$I_a = 50,000 \times 1.330 \text{ (Column 4)}$$

$$= 66,500 \text{ Amperes RMS Asymmetrical}$$

With this basic understanding, proceed in the systems analysis.

Interrupting Rating, Interrupting Capacity and Short-Circuit Currents

Interrupting Rating can be defined as “the maximum short-circuit current that a protective device can safely clear, under specified test conditions.”

Interrupting Capacity can be defined as “the actual short circuit current that a protective device has been tested to interrupt.”

The National Electrical Code requires adequate interrupting ratings in Sections 110-9 and 230-65.

Section 110-9 Interrupting Rating. Equipment intended to break current at fault levels shall have an interrupting rating sufficient for the system voltage and the current which is available at the line terminals of the equipment.

Section 230-65. Available Short-Circuit Current. Service Equipment shall be suitable for the short circuit current available at its supply terminals.

Low voltage fuses have their interrupting rating expressed in terms of the symmetrical component of short-circuit current, I_s . They are given an RMS symmetrical interrupting rating at a specific power factor. This means that the fuse can interrupt any asymmetrical current associated with this rating. Thus only the symmetrical component of short-circuit current need be considered to determine the necessary interrupting rating of a low voltage fuse. For U.L. listed low voltage fuses, interrupting rating equals its interrupting capacity.

Low voltage molded case circuit breakers also have their interrupting rating expressed in terms of RMS symmetrical amperes at a specific power factor. However, it is necessary to determine a molded case circuit breaker's interrupting capacity in order to safely apply it. The reader is directed to Buss bulletin PMCB II for an understanding of this concept.

Procedures and Methods

3Ø Short-Circuit Current Calculations, Procedures and Methods

To determine the fault current at any point in the system, first draw a one-line diagram showing all of the sources of short-circuit current feeding into the fault, as well as the impedances of the circuit components.

To begin the study, the system components, including those of the utility system, are represented as impedances in the diagram.

The impedance tables given in the Data Section include three phase and single phase transformers, current transformers, safety switches, circuit breakers, cable, and busway. These tables can be used if information from the manufacturers is not readily available.

It must be understood that short circuit calculations are performed without current limiting devices in the system. Calculations are done as though these devices are replaced with copper bars, to determine the maximum “available” short circuit current. This is necessary to project how the system and the current limiting devices will perform.

Also, current limiting devices do not operate in series to produce a “compounding” current limiting effect. The downstream, or load side, fuse will operate alone under a short circuit condition if properly coordinated.

To begin the analysis, consider the following system, supplied by a 1500 KVA, three phase transformer having a full load current of 1804 amperes at 480 volts. (See System A, below) Also, System B, for a double transformation, will be studied.

To start, obtain the available short-circuit KVA, MVA, or SCA from the local utility company.

The utility estimates that System A can deliver a short-circuit of 100,000 MVA at the primary of the transformer. System B can deliver a short-circuit of 500,000 KVA at the primary of the first transformer. Since the X/R ratio of the utility system is usually quite high, only the reactance need be considered.

With this available short-circuit information, begin to make the necessary calculations to determine the fault current at any point in the electrical system.

Four basic methods will be presented in this text to instruct the reader on short circuit calculations.

These include :

- the ohmic method
- the per unit method
- the TRON® Computer Software method
- the point to point method

System A 3Ø Single Transformer System

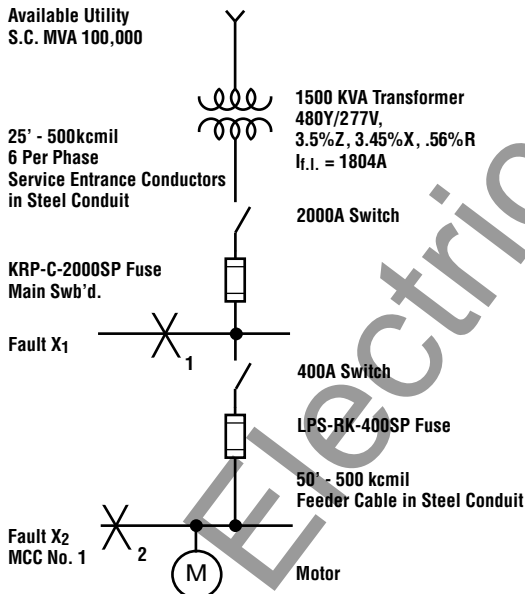

Note: The above 1500KVA transformer serves 100% motor load.

System B 3Ø Double Transformer System

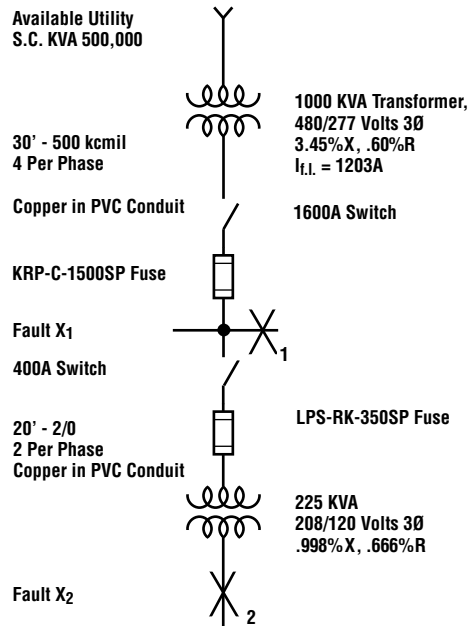

In this example, assume 0% motor load.

Ohmic Method

3Ø Short Circuit Calculations, Ohmic Method

Most circuit component impedances are given in ohms except utility and transformer impedances which are found by the following formulae* (Note that the transformer and utility ohms are referred to the secondary KV by squaring the secondary voltage.)

Step 1.
$${}^{\dagger}X_{\text{utility } \Omega} = \frac{1000 (KV_{\text{secondary}})^2}{\text{S.C. KVA}_{\text{utility}}}$$

Step 2.
$$X_{\text{trans } \Omega} = \frac{(10)(\%X^{**})(KV_{\text{secondary}})^2}{\text{KVA}_{\text{trans}}}$$

$$R_{\text{trans } \Omega} = \frac{(10)(\%R^{**})(KV_{\text{secondary}})^2}{\text{KVA}_{\text{trans}}}$$

Step 3. The impedance (in ohms) given for current transformers, large switches and large circuit breakers is essentially all X.

Step 4.
$$X_{\text{cable and bus } \Omega}$$

$$R_{\text{cable and bus } \Omega}$$

Step 5. Total all **X** and all **R** in system to point of fault.

Step 6. Determine impedance (in ohms) of the system by:

$$Z_T = \sqrt{(R_T)^2 + (X_T)^2}$$

Step 7. Calculate short-circuit symmetrical RMS amperes at the point of fault.

$$I_{\text{s.c. sym RMS}} = \frac{E_{\text{secondary line-line}}}{\sqrt{3} (Z_T)}$$

Step 8. Determine the motor load. Add up the full load motor currents. The full load motor current in the system is generally a percentage of the transformer full load current, depending upon the types of loads. The generally accepted procedure assumes 50% motor load when both motor and lighting loads are considered, such as supplied by 4 wire, 208Y/120V and 480Y/277V volt 3-phase systems.)

Step 9. The symmetrical motor contribution can be approximated by using an average multiplying factor associated with the motors in the system. This factor varies according to motor design and in this text may be chosen as 4 times motor full load current for approximate calculation purposes. To solve for the symmetrical motor contribution:

$${}^*I_{\text{sym motor contrib}} = (4) \times (I_{\text{full load motor}})$$

Step 10. The total symmetrical short-circuit RMS current is calculated as:

$${}^{\dagger\dagger}I_{\text{total S.C. sym RMS}} = (I_{\text{s.c. sym RMS}}) + (I_{\text{sym motor contrib}})$$

Step 11. Determine X/R ratio of the system to the point of fault.

$$X/R_{\text{ratio}} = \frac{X_{\text{total } \Omega}}{R_{\text{total } \Omega}}$$

Step 12. The asymmetrical factor corresponding to the X/R ratio in Step 11 is found in Table 8, Column **M_m**. This multiplier will provide the worst case asymmetry occurring in the first 1/2 cycle. When the average 3-phase multiplier is desired use column **M_a**.

Step 13. Calculate the asymmetrical RMS short-circuit current.

$$I_{\text{s.c. asym RMS}} = (I_{\text{s.c. sym RMS}}) \times (\text{Asym Factor})$$

Step 14. The short-circuit current that the motor load can contribute is an asymmetrical current usually approximated as being equal to the locked rotor current of the motor.

•As a close approximation with a margin of safety use:

$${}^*I_{\text{asym motor contrib}} = (5) \times (I_{\text{full load motor}})$$

Step 15. The total asymmetrical short-circuit RMS current is calculated as:

$$I_{\text{total S.C. asym RMS}} = (I_{\text{s.c. asym RMS}}) + (I_{\text{asym motor contrib}})$$

*For simplicity of calculations all ohmic values are single phase distance one way, later compensated for in the three phase short-circuit formula by the factor, $\sqrt{3}$. (See Step 7.)

**UL Listed transformers 25 KVA and larger have a $\pm 10\%$ impedance tolerance. Short circuit amperes can be affected by this tolerance.

†Only X is considered in this procedure since utility X/R ratios are usually quite high. For more finite details obtain R of utility source.

•A more exact determination depends upon the sub-transient reactance of the motors in question and associated circuit impedances. A less conservative method would involve the total motor circuit impedance to a common bus (sometimes referred to as a "zero reactance bus").

††Arithmetical addition results in conservative values of fault current. More finite values involve vectorial addition of the currents.

Note: The ohms of the circuit components must be referred to the same voltage. If there is more than one voltage transformation in the system, the ohmic method becomes more complicated. It is recommended that the per-unit method be used for ease in calculation when more than one voltage transformation exists in the system.

Ohmic Method – To Fault X₁ – System A

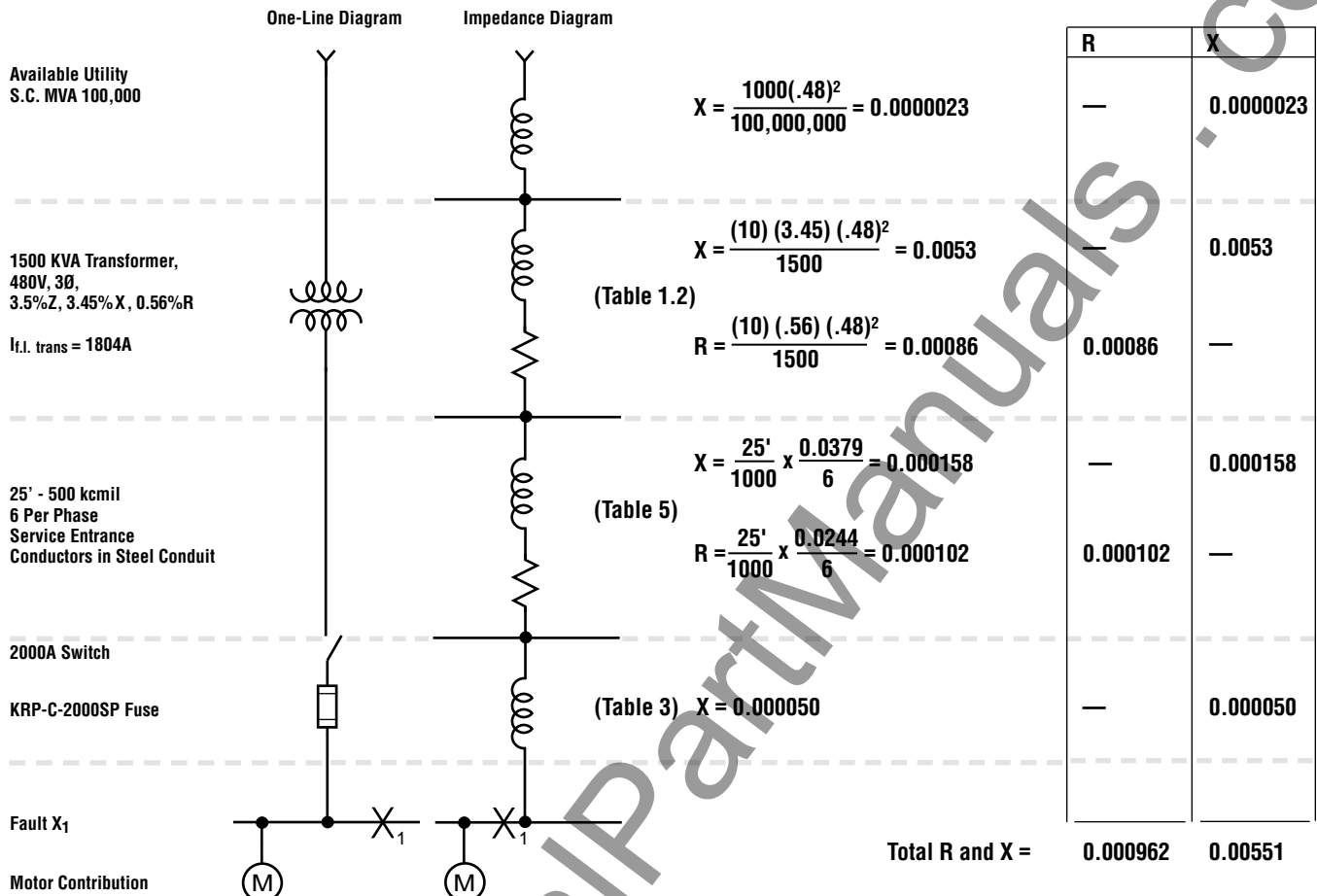

$$Z_{\text{total per phase}} = \sqrt{(0.000962)^2 + (0.00551)^2} = 0.0056\Omega$$

$$I_{\text{S.C. sym RMS}} = \frac{480}{\sqrt{3} (0.0056)} = 49,489\text{A}$$

$$I_{\text{sym motor contrib}} = 4 \times 1804 = 7216\text{A}$$

(100% motor load)

$$I_{\text{total S.C. sym RMS}} = 49,489 + 7216 = \underline{56,705\text{A}}$$

(fault X₁)

$$X/R_{\text{ratio}} = \frac{0.00551}{0.000962} = 5.73$$

Asym Factor = 1.294 (Table 8)

$$I_{\text{S.C. asym RMS}} = 1.294 \times 49,489 = 64,039\text{A}$$

$$I_{\text{asym motor contrib}} = 5 \times 1804 = 9,020\text{A}$$

(100% motor load)

$$I_{\text{total S.C. asym RMS}} = 64,039 + 9,020 = \underline{73,059\text{A}}$$

(fault X₁)

Note: See Ohmic Method Procedure for Formulas.

Ohmic Method – To Fault X₂ – System A

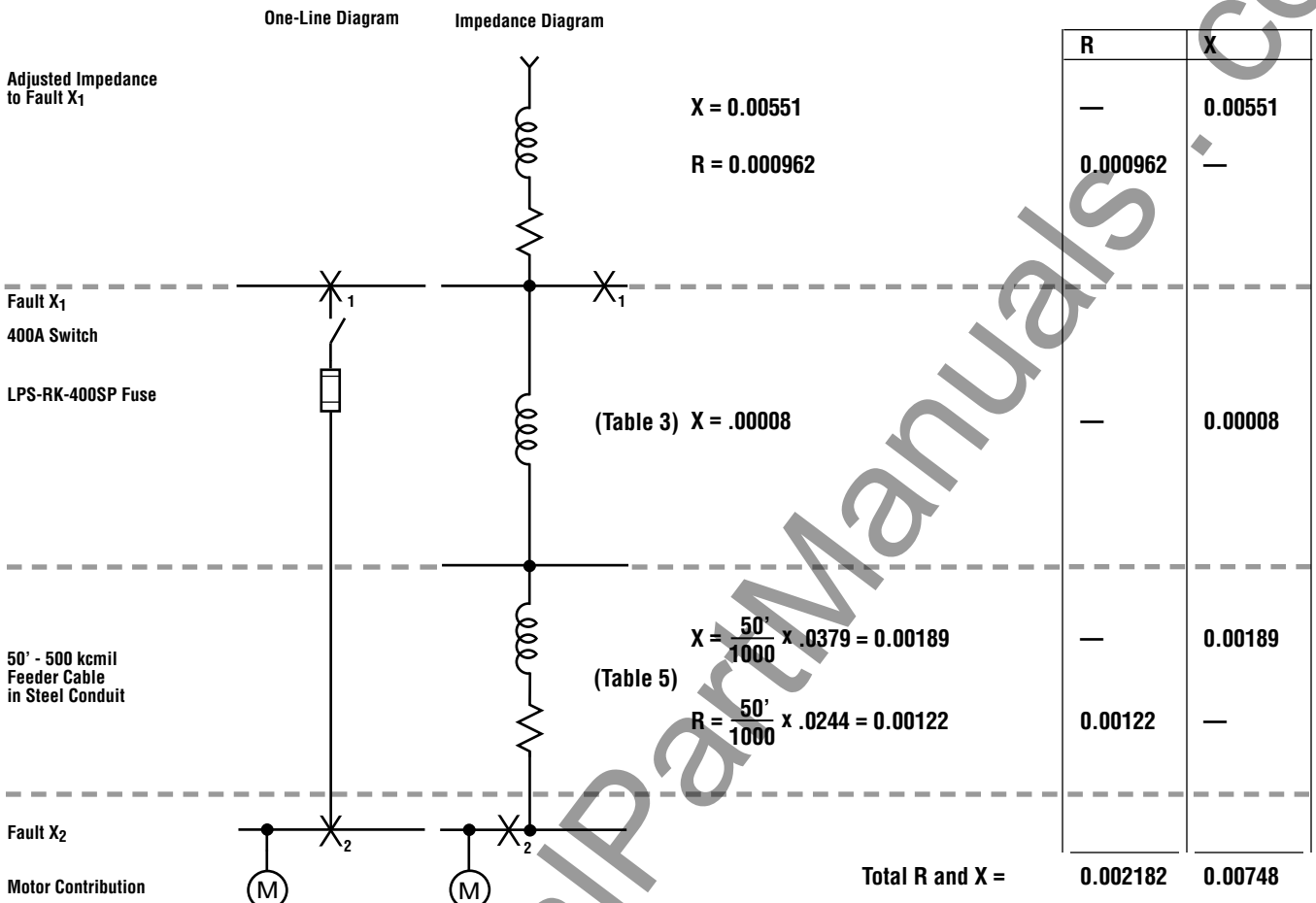

$$Z_{\text{total per phase}} = \sqrt{(0.002182)^2 + (0.00748)^2} = 0.00778\Omega$$

$$I_{\text{s.c. sym RMS}} = \frac{480}{\sqrt{3} (.00778)} = 35,621\text{A}$$

$$I_{\text{sym motor contrib}} = 4 \times 1804 = 7216\text{A}$$

(100% motor load)

$$I_{\text{total S.C. sym RMS}} = 35,621 + 7,216 = \underline{42,837\text{A}}$$

(fault X₂)

$$X/R_{\text{ratio}} = \frac{.00748}{.002182} = 3.43$$

Asym Factor = 1.149 (Table 8)

$$I_{\text{s.c. asym RMS}} = 1.149 \times 35,621 = 40,929\text{A}$$

$$I_{\text{asym motor contrib}} = 5 \times 1804 = 9,020\text{A}$$

(100% motor load)

$$I_{\text{total S.C. asym RMS}} = 40,929 + 9,020 = \underline{49,949\text{A}}$$

(fault X₂)

Note: See Ohmic Method Procedure for Formulas. Actual motor contribution will be somewhat smaller than calculated due to the impedance of the feeder cable.

Ohmic Method – To Fault X₁ – System B

To use the OHMIC Method through a second transformer, the following steps apply:

Step 1a. Summarize X and R values of all components on primary side of transformer.

Step 1b. Reflect X and R values of all components to secondary side of transformer

$$X_s = \frac{V_s^2}{V_p^2}(X_p) \quad R_s = \frac{V_s^2}{V_p^2}(R_p)$$

and proceed with steps 2 thru 15 from page 6.

	One-Line Diagram	Impedance Diagram		R	X
Available Utility 500,000 S.C. KVA			$X = \frac{1000 (.48)^2}{500,000} = .000461$	—	.000461
1000KVA Transformer, 480V, 3Ø, 3.45% X, .60% R			$X = \frac{(10)(3.45)(.48)^2}{1000} = .00795$ $R = \frac{(10)(.60)(.48)^2}{1000} = .00138$	—	.00795
30' - 500 kcmil 4 Per Phase Copper in PVC Conduit			$X = \frac{30^4}{1000} \times \frac{.0303}{4} = .000227$ $R = \frac{30^4}{1000} \times \frac{.0220}{4} = .000165$.00138	—
1600A Switch KRP-C-1500SP Fuse			$X = .000050$	—	.00005
			Total R and X =	.001545	.008688

$$Z_{total \text{ per phase}} = \sqrt{(.001545)^2 + (.008688)^2} = .008824\Omega$$

$$I_{s.c. \text{ sym RMS}} = \frac{480}{\sqrt{3} (.008824)} = 31,405A$$

$$X/R_{ratio} = \frac{.008688}{.001545} = 5.62$$

Asym Factor = 1.285 (Table 8)

$$I_{s.c. \text{ asym RMS}} = 31,405 \times 1.285 = 40,355A$$

Ohmic Method – To Fault X₂ – System B

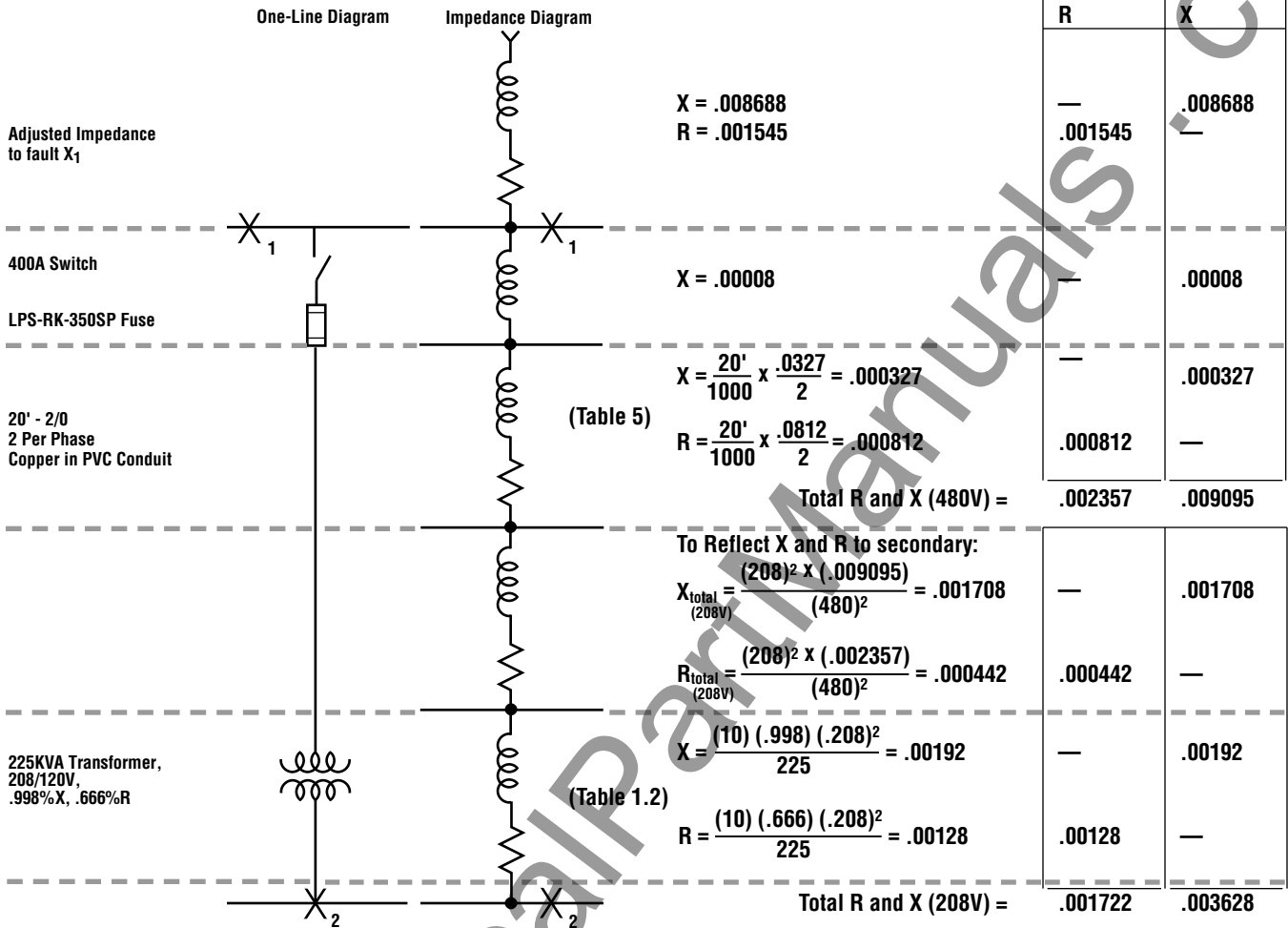

$$Z_{total\ per\ phase} = \sqrt{(.001722)^2 + (.003628)^2} = .004015\Omega$$

$$I_{s.c.\ sym\ RMS} = \frac{208}{\sqrt{3} (.004015)} = 29,911A$$

$$X/R_{ratio} = \frac{.003628}{.001722} = 2.10$$

Asym Factor = 1.0491 (Table 8)

$$I_{s.c.\ asym\ RMS} = 29,911 \times 1.0491 = 31,380A$$

Per-Unit Method

3Ø Short Circuit Calculation Per-Unit Method*

The per-unit method is generally used for calculating short-circuit currents when the electrical system is more complex.

After establishing a one-line diagram of the system, proceed to the following calculations: **

$$\text{Step 1. } \dagger \text{PUX}_{\text{utility}} = \frac{\text{KVA}_{\text{base}}}{\text{S.C. KVA}_{\text{utility}}}$$

$$\text{Step 2. } \text{PUX}_{\text{trans}} = \frac{(\%X)(\text{KVA}_{\text{base}})}{(100)(\text{KVA}_{\text{trans}})}$$

$$\text{PUR}_{\text{trans}} = \frac{(\%R)(\text{KVA}_{\text{base}})}{(100)(\text{KVA}_{\text{trans}})}$$

$$\text{Step 3. } \text{PUX}_{\text{component (cable, switches, CT, bus)}} = \frac{(X_{\Omega})(\text{KVA}_{\text{base}})}{(1000)(\text{KV})^2}$$

$$\text{Step 4. } \text{PUR}_{\text{component (cable, switches, CT, bus)}} = \frac{(R_{\Omega})(\text{KVA}_{\text{base}})}{(1000)(\text{KV})^2}$$

Step 5. Next, total all per-unit **X** and all per-unit **R** in system to point of fault.

Step 6. Determine the per-unit impedance of the system by:

$$\text{PUZ}_{\text{total}} = \sqrt{(\text{PUR}_{\text{total}})^2 + (\text{PUX}_{\text{total}})^2}$$

Step 7. Calculate the symmetrical RMS short-circuit current at the point of fault.

$$\text{I}_{\text{S.C. sym RMS}} = \frac{\text{KVA}_{\text{base}}}{\sqrt{3} (\text{KV})(\text{PUZ}_{\text{total}})}$$

Step 8. Determine the motor load. Add up the full load motor currents. (Whenever motor and lighting loads are considered, such as supplied by 4 wire, 208Y/120 and 480Y/277 volt 3 phase systems, the generally accepted procedure is to assume 50% motor load based on the full load current rating of the transformer.)

Step 9. The symmetrical motor contribution can be approximated by using an average multiplying factor associated with the motors in the system. This factor varies according to motor design and in this text may be chosen as 4 times motor full load current for approximate calculation purposes. To solve for the symmetrical motor contribution:

$$***\text{I}_{\text{sym motor contrib}} = (4) \times (\text{I}_{\text{full load motor}})$$

Step 10. The total symmetrical short-circuit rms current is calculated as:

$$**\text{I}_{\text{total S.C. sym RMS}} = (\text{I}_{\text{S.C. sym RMS}}) + (\text{I}_{\text{sym motor contrib}})$$

Step 11. Determine X/R ratio of the system to the point of fault.

$$\text{X/R}_{\text{ratio}} = \frac{\text{PUX}_{\text{total}}}{\text{PUR}_{\text{total}}}$$

Step 12. From Table 8, Column **M_m**, obtain the asymmetrical factor corresponding to the X/R ratio determined in Step 11. This multiplier will provide the worst case asymmetry occurring in the first 1/2 cycle. When the average 3-phase multiplier is desired use column **M_a**.

Step 13. The asymmetrical RMS short-circuit current can be calculated as:

$$\text{I}_{\text{S.C. asym RMS}} = (\text{I}_{\text{S.C. sym RMS}}) \times (\text{Asym Factor})$$

Step 14. The short-circuit current that the motor load can contribute is an asymmetrical current usually approximated as being equal to the locked rotor current of the motor.*** As a close approximation with a margin of safety use:

$$***\text{I}_{\text{asym motor contrib}} = (5) \times (\text{I}_{\text{full load motor}})$$

Step 15. The total asymmetrical short-circuit RMS current is calculated as:

$$**\text{I}_{\text{total S.C. asym RMS}} = (\text{I}_{\text{S.C. asym RMS}}) + (\text{I}_{\text{asym motor contrib}})$$

* The base KVA used throughout this text will be 10,000 KVA.

** As in the ohmic method procedure, all ohmic values are single-phase distance one way, later compensated for in the three phase short-circuit formula by the factor, $\sqrt{3}$. (See Step 7.)

• UL Listed transformers 25KVA and larger have a $\pm 10\%$ impedance tolerance. Short circuit amperes can be affected by this tolerance.

† Only per-unit X is considered in this procedure since utility X/R ratio is usually quite high. For more finite details obtain per-unit R of utility source.

*** A more exact determination depends upon the sub-transient reactance of the motors in question and associated circuit impedances. A less conservative method would involve the total motor circuit impedance to a common bus (sometimes referred to as a "zero reactance bus").

• Arithmetic addition results in conservative values of fault current. More finite values involve vectorial addition of the currents.

Per-Unit Method – To Fault X₁ – System A

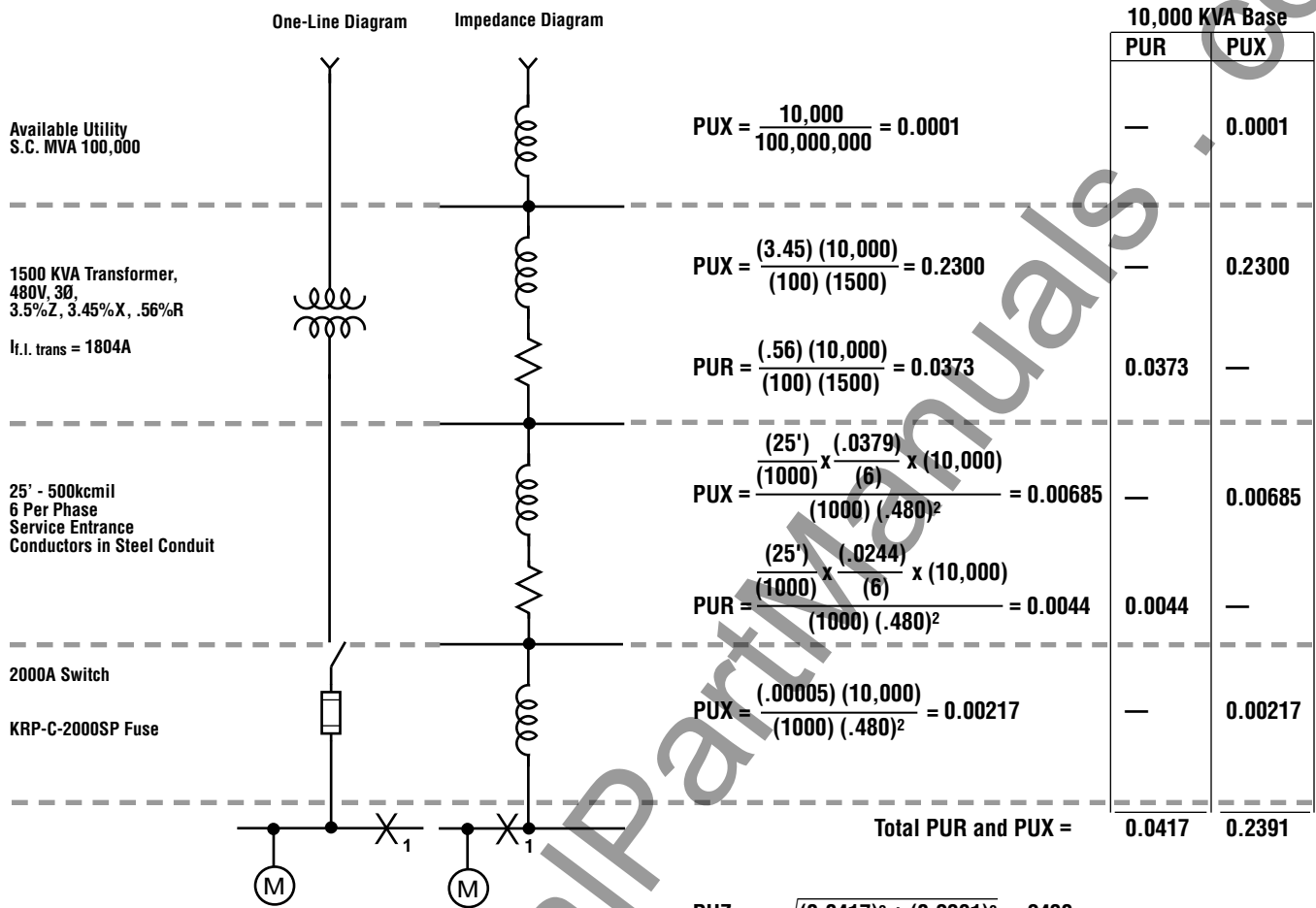

$$PUZ_{total} = \sqrt{(0.0417)^2 + (0.2391)^2} = .2430$$

$$I_{s.c. \text{ sym RMS}} = \frac{10,000}{\sqrt{3} (.480)(.2430)} = 49,489A$$

$$I_{\text{sym motor contrib}} = 4 \times 1804 = 7,216A$$

$$I_{\text{total S.C. sym RMS}} = 49,489 + 7,216 = \underline{56,705A} \text{ (fault X}_1\text{)}$$

$$X/R_{\text{ratio}} = \frac{.2391}{.0417} = 5.73$$

* Asym Factor = 1.294 (Table 8)

$$I_{s.c. \text{ asym RMS}} = 49,489 \times 1.294 = 64,039A$$

$$I_{\text{asym motor contrib}} = 5 \times 1804 = 9,020A \text{ (100\% motor load)}$$

$$I_{\text{total S.C. asym RMS}} = 64,039 + 9,020 = \underline{73,059A} \text{ (fault X}_1\text{)}$$

Note: See Per Unit Method Procedure for Formulas.
Actual motor contribution will be somewhat smaller than calculated due to impedance of the feeder cable.

Per-Unit Method – To Fault X₂ – System A

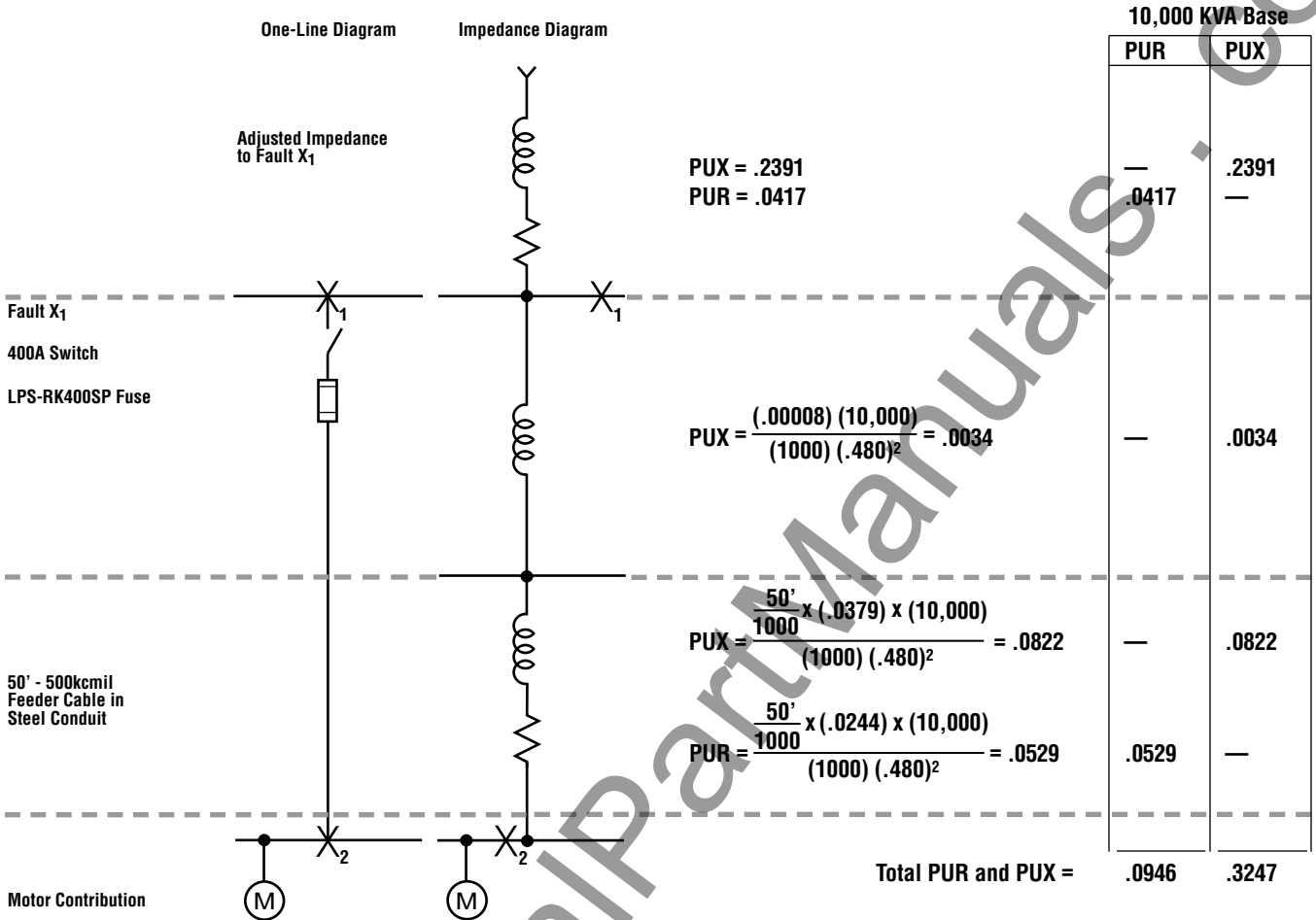

$$\begin{aligned} \text{PUX} &= .2391 \\ \text{PUR} &= .0417 \end{aligned}$$

$$\text{PUX} = \frac{(.00008)(10,000)}{(1000)(.480)^2} = .0034$$

$$\text{PUX} = \frac{\frac{50'}{1000} \times (.0379) \times (10,000)}{(1000)(.480)^2} = .0822$$

$$\text{PUR} = \frac{\frac{50'}{1000} \times (.0244) \times (10,000)}{(1000)(.480)^2} = .0529$$

Total PUR and PUX =

$$\text{PUZ}_{\text{total}} = \sqrt{(.0946)^2 + (.3247)^2} = 0.3380$$

$$I_{\text{S.C. sym RMS}} = \frac{10,000}{\sqrt{3}(.480)(.3380)} = 35,621\text{A}$$

$$I_{\text{sym motor contrib}} = 4 \times 1804 = 7,216\text{A}$$

$$I_{\text{total S.C. sym RMS (fault X}_2)} = 35,621 + 7,216 = \underline{42,837\text{A}}$$

$$\text{X/R}_{\text{ratio}} = \frac{.32477}{.09465} = 3.43$$

Asym Factor = 1.149 (Table 8)

$$I_{\text{S.C. asym RMS}} = 1.149 \times 35,621 = 40,929\text{A}$$

$$I_{\text{asym motor contrib (100\% motor load)}} = 5 \times 1804 = 9,020\text{A}$$

$$I_{\text{total S.C. asym RMS (fault X}_2)} = 40,929 + 9,020 = \underline{49,949\text{A}}$$

Per-Unit Method – To Fault X₁ – System B

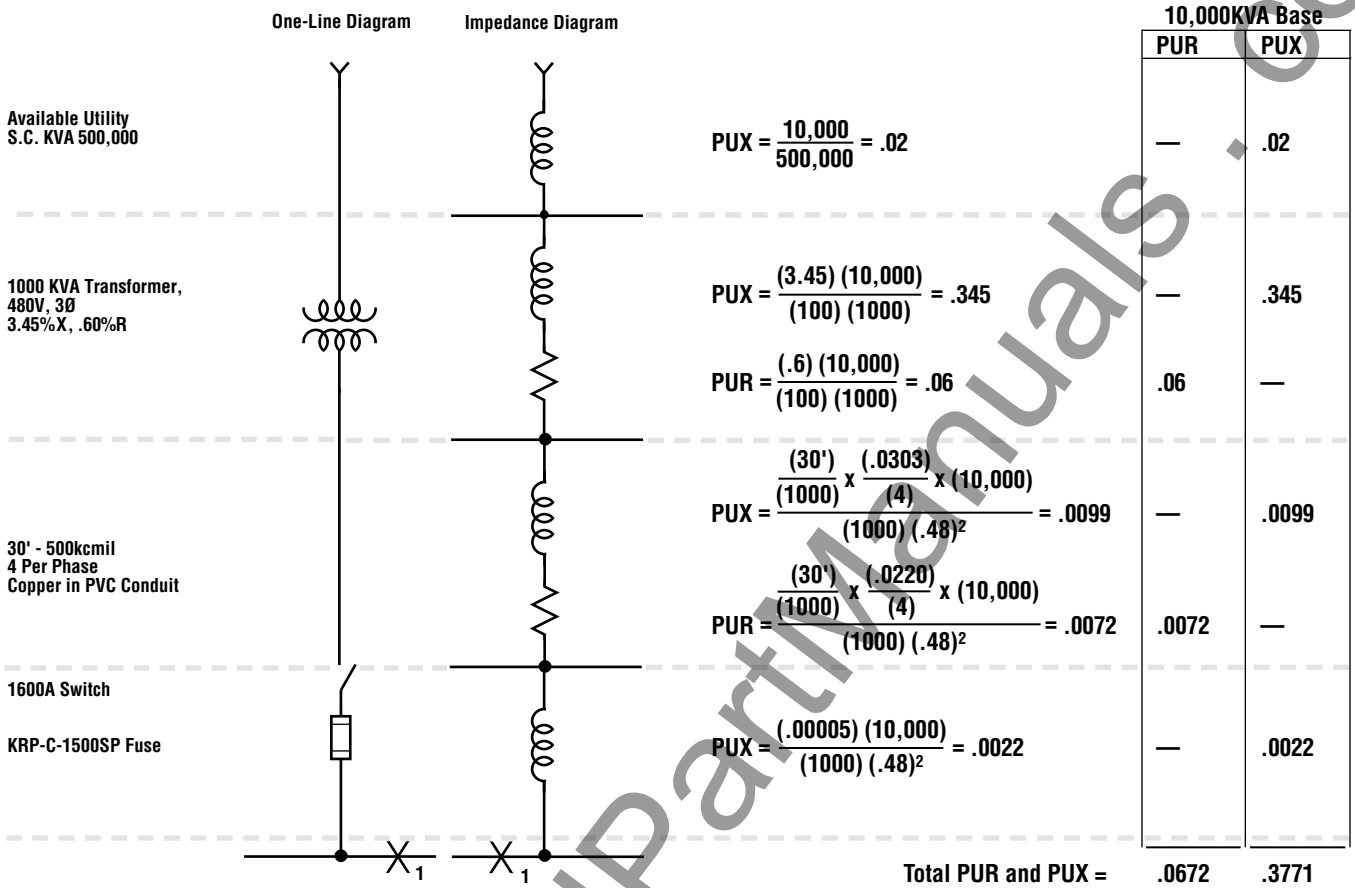

$$PUZ_{total} = \sqrt{(.0672)^2 + (.3771)^2} = .383$$

$$I_{s.c. \text{ sym RMS}} = \frac{10,000}{\sqrt{3} (.48)(.383)} = 31,405A$$

$$X/R_{ratio} = \frac{.3771}{.0672} = 5.62$$

Asym Factor = 1.285 (Table 8)

$$I_{s.c. \text{ asym RMS}} = 31,405 \times 1.285 = 40,355A$$

Per-Unit Method – To Fault X₂– System B

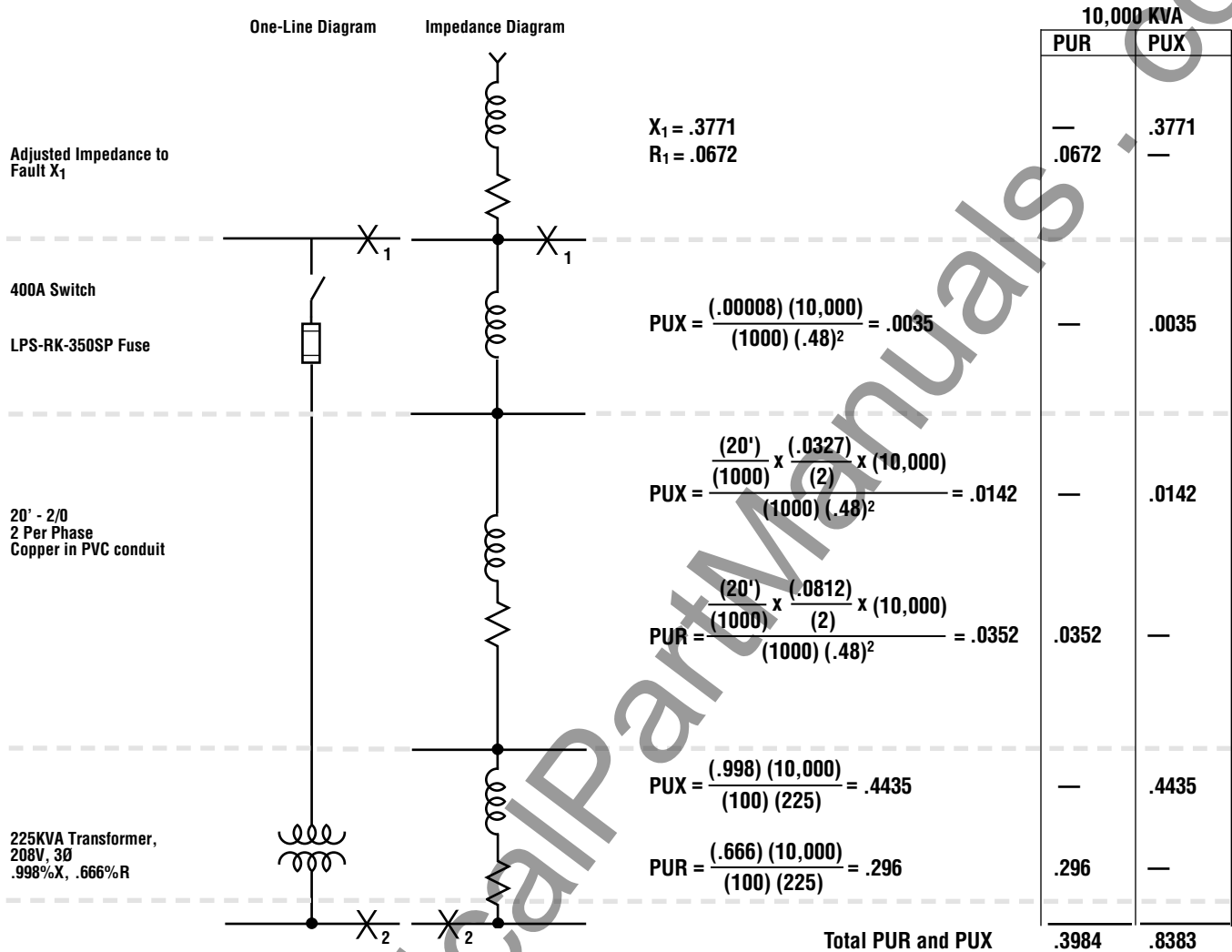

$$PUZ_{total} = \sqrt{(.3984)^2 + (.8383)^2} = .928$$

$$I_{s.c. sym RMS} = \frac{10,000}{\sqrt{(3)(.208)(.928)}} = 29,911A$$

$$X/R_{ratio} = \frac{.8383}{.3984} = 2.10$$

Asym Factor = 1.0491 (Table 8)

$$I_{s.c. asym RMS} = 29,911 \times 1.0491 = 31,380A$$

TRON[®] Computer Software Method

BUSSPOWER[®] is a Computer Software Program which calculates three phase fault currents. It is a part of the TRON[®] Software Package for Power Systems Analysis. The user inputs data which includes:

- Cable and Busway Lengths and Types
- Transformer Rating and Impedance
- Fault sources such as Utility Available and Motor Contribution.

Following the data input phase, the program is executed and an output report reviewed.

The following is a partial output report of System A being studied.

TRON[®] Software Fault Calculation Program – Three Phase Fault Report

SYSTEM A			
Bus Record Name	Fault Study Summary		
	Voltage L-L	Available RMS Duties	
		3 Phase (Sym)	Momentary (Asym)
X1	480	58414	77308
X2	480	44847	53111

The following is a partial output report of the distribution System B.

SYSTEM B			
Bus Record Name	Fault Study Summary		
	Voltage L-L	Available RMS Duties	
		3 Phase (Sym)	Momentary (Asym)
X1	480	31,363	40,141
X2	208	29,980	31,425

A further description of this program and its capabilities is on the back cover of this bulletin.

Point-to-Point Method

The application of the point-to-point method permits the determination of available short-circuit currents with a reasonable degree of accuracy at various points for either 3Ø or 1Ø electrical distribution systems. This method can assume unlimited primary short-circuit current (infinite bus).

Basic Point-to-Point Calculation Procedure

Step 1. Determine the transformer full load amperes from either the nameplate or the following formulas:

$$3\text{Ø Transformer } I_{f.l.} = \frac{\text{KVA} \times 1000}{E_{L-L} \times 1.732}$$

$$1\text{Ø Transformer } I_{f.l.} = \frac{\text{KVA} \times 1000}{E_{L-L}}$$

Step 2. Find the transformer multiplier.

$$\text{Multiplier} = \frac{100}{\%Z_{\text{trans}}}$$

* **Note.** Transformer impedance (Z) helps to determine what the short circuit current will be at the transformer secondary. Transformer impedance is determined as follows: The transformer secondary is short circuited. Voltage is applied to the primary which causes full load current to flow in the secondary. This applied voltage divided by the rated primary voltage is the impedance of the transformer.

Example: For a 480 volt rated primary, if 9.6 volts causes secondary full load current to flow through the shorted secondary, the transformer impedance is $9.6/480 = .02 = 2\%Z$.

In addition, UL listed transformer 25KVA and larger have a $\pm 10\%$ impedance tolerance. Short circuit amperes can be affected by this tolerance.

Step 3. Determine the transformer let-thru short-circuit current**.

$$I_{s.c.} = I_{f.l.} \times \text{Multiplier}$$

** **Note.** Motor short-circuit contribution, if significant, may be added to the transformer secondary short-circuit current value as determined in Step 3. Proceed with this adjusted figure through Steps 4, 5 and 6. A practical estimate of motor short-circuit contribution is to multiply the total motor current in amperes by 4.

Step 4. Calculate the "f" factor.

3Ø Faults

$$f = \frac{1.732 \times L \times I}{C \times E_{L-L}}$$

1Ø Line-to-Line (L-L)

Faults on 1Ø Center Tapped Transformer

$$f = \frac{2 \times L \times I}{C \times E_{L-L}}$$

1Ø Line-to-Neutral (L-N) Faults on 1Ø

Center Tapped Transformer

$$f = \frac{2 \times L \times I^\dagger}{C \times E_{L-N}}$$

Where:

L = length (feet) of circuit to the fault.

C = constant from Table 6, page 27. For parallel runs, multiply C values by the number of conductors per phase.

I = available short-circuit current in amperes at beginning of circuit.

† **Note.** The L-N fault current is higher than the L-L fault current at the secondary terminals of a single-phase center-tapped transformer. The short-circuit current available (I) for this case in Step 4 should be adjusted at the transformer terminals as follows:

At L-N center tapped transformer terminals,

$$I = 1.5 \times \text{L-L Short-Circuit Amperes at Transformer Terminals}$$

At some distance from the terminals, depending upon wire size, the L-N fault current is lower than the L-L fault current. The 1.5 multiplier is an approximation and will theoretically vary from 1.33 to 1.67. These figures are based on change in turns ratio between primary and secondary, infinite source available, zero feet from terminals of transformer, and $1.2 \times \%X$ and $1.5 \times \%R$ for L-N vs. L-L resistance and reactance values. Begin L-N calculations at transformer secondary terminals, then proceed point-to-point.

Step 5. Calculate "M" (multiplier).

$$M = \frac{1}{1 + f}$$

Step 6. Calculate the available short-circuit symmetrical RMS current at the point of fault.

$$I_{s.c. \text{ sym RMS}} = I_{s.c.} \times M$$

Calculation of Short-Circuit Currents at Second Transformer in System

Use the following procedure to calculate the level of fault current at the secondary of a second, downstream transformer in a system when the level of fault current at the transformer primary is known.

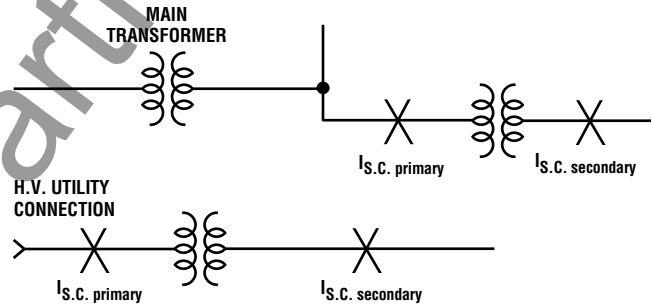

Procedure for Second Transformer in System

Step 1. Calculate the "f" factor ($I_{s.c. \text{ primary}}$ known)

3Ø Transformer

($I_{s.c. \text{ primary}}$ and $I_{s.c. \text{ secondary}}$ are 3Ø fault values)

$$f = \frac{I_{s.c. \text{ primary}} \times V_{\text{primary}} \times 1.73 (\%Z)}{100,000 \times \text{KVA}_{\text{trans}}}$$

1Ø Transformer

($I_{s.c. \text{ primary}}$ and $I_{s.c. \text{ secondary}}$ are 1Ø fault values: $I_{s.c. \text{ secondary}}$ is L-L)

$$f = \frac{I_{s.c. \text{ primary}} \times V_{\text{primary}} \times (\%Z)}{100,000 \times \text{KVA}_{\text{trans}}}$$

Step 2. Calculate "M" (multiplier).

$$M = \frac{1}{1 + f}$$

Step 3. Calculate the short-circuit current at the secondary of the transformer. (See Note under Step 3 of "Basic Point-to-Point Calculation Procedure".)

$$I_{s.c. \text{ secondary}} = \frac{V_{\text{primary}}}{V_{\text{secondary}}} \times M \times I_{s.c. \text{ primary}}$$

Point-to-Point Method – To Faults X₁ & X₂ – System A

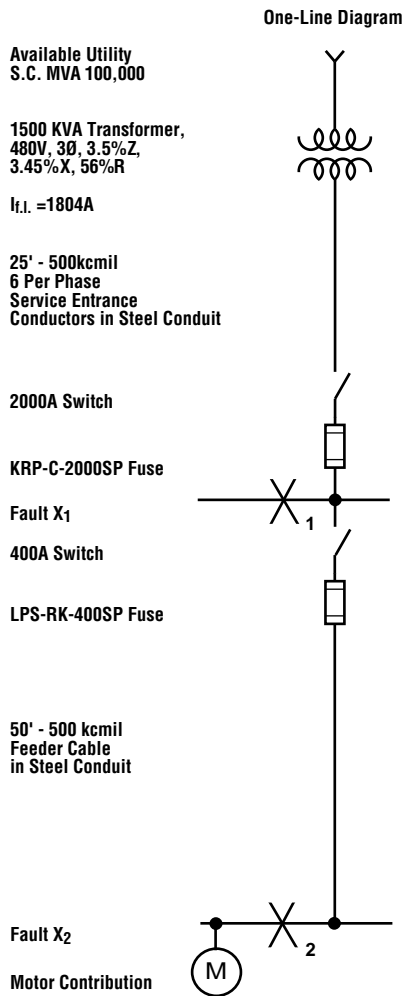

Fault X₁

Step 1. $I_{f.l.} = \frac{1500 \times 1000}{480 \times 1.732} = 1804A$

Step 2. $\text{Multiplier} = \frac{100}{3.5} = 28.57$

Step 3. $I_{s.c.} = 1804 \times 28.57 = 51,540A$

Step 4. $f = \frac{1.732 \times 25 \times 51,540}{6 \times 22,185 \times 480} = 0.0349$

Step 5. $M = \frac{1}{1 + .0349} = .9663$

Step 6. $I_{s.c.\text{sym RMS}} = 51,540 \times .9663 = 49,803A$

$I_{s.c.\text{motor contrib}} = 4 \times 1,804 = 7,216A$

$I_{\text{total S.C. sym RMS}} = 49,803 + 7,216 = 57,019A$
(fault X₁)

Fault X₂

Step 4. Use $I_{s.c.\text{sym RMS}}$ @ Fault X₁ to calculate "f"

$f = \frac{1.732 \times 50 \times 49,803}{22,185 \times 480} = .4050$

Step 5. $M = \frac{1}{1 + .4050} = .7117$

Step 6. $I_{s.c.\text{sym RMS}} = 49,803 \times .7117 = 35,445A$

$I_{\text{sym motor contrib}} = 4 \times 1,804 = 7,216A$

$I_{\text{total S.C. sym RMS}} = 35,445 + 7,216 = 42,661A$
(fault X₂)

Point-to-Point Method – To Faults X₁ & X₂ - System B

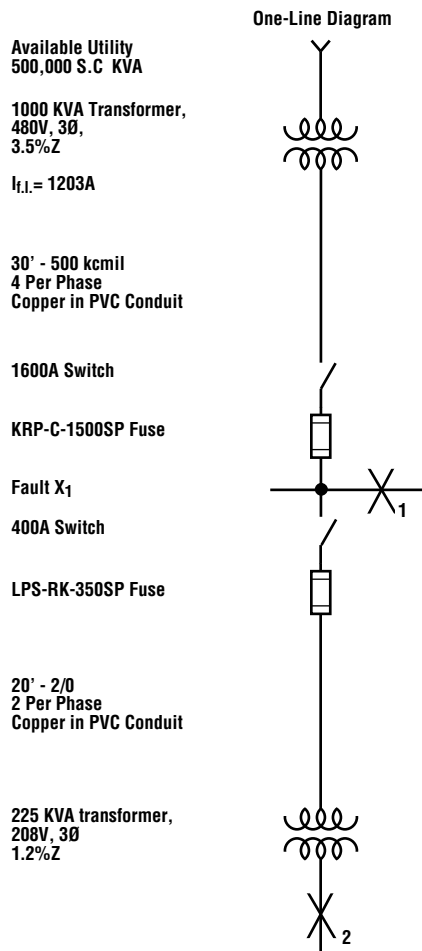

Fault X₁

Step 1. $I_{r.l.} = \frac{1000 \times 1000}{480 \times 1.732} = 1203A$

Step 2. Multiplier = $\frac{100}{3.5} = 28.57$

Step 3. $I_{s.c.} = 1203 \times 28.57 = 34,370A$

Step 4. $f = \frac{1.732 \times 30 \times 34,370}{4 \times 26,706 \times 480} = .0348$

Step 5. $M = \frac{1}{1 + .0348} = .9664$

Step 6. $I_{s.c.sym RMS} = 34,370 \times .9664 = 33,215A$

Fault X₂

Step 4. $f = \frac{1.732 \times 20 \times 33,215}{2 \times 11,423 \times 480} = .1049$

Step 5. $M = \frac{1}{1 + .1049} = .905$

Step 6. $I_{s.c.sym RMS} = 33,215 \times .905 = 30,059A$

Fault X₂

$$f = \frac{30,059 \times 480 \times 1.732 \times 1.2}{100,000 \times 225} = 1.333$$

$$M = \frac{1}{1 + 1.333} = .4286$$

$$I_{s.c. sym RMS} = \frac{480 \times .4286 \times 30,059}{208} = 29,731A$$

3Ø Short-Circuit Current Calculations – RMS Amperes

Comparison of Results

System A

	Ohmic		Per-Unit		TRON®		PTP
	Sym.	Asym.	Sym.	Asym.	Sym.	Asym.	Sym.
X₁							
W/O Motor	49,489	64,039	49,489	64,039	49,992	64,430	49,803
W/Motor	56,705	73,059	56,705	73,059	58,414	77,308	57,019
X₂							
W/O Motor	35,621	40,929	35,621	40,929	36,126	41,349	35,445
W/Motor	42,837	49,949	42,837	49,949	44,847	53,111	42,661

Notes:

1. OHMIC and PER UNIT methods assume 100% motor contribution at X₁, then at X₂.
2. TRON modeled 100% motor contribution by assuming 1500 HP load, located at Point X₂.
3. PTP method added symmetrical motor contribution at X₁, then at X₂.

System B

	Ohmic		Per-Unit		TRON®		PTP
	Sym.	Asym.	Sym.	Asym.	Sym.	Asym.	Sym.
X₁	31,405	40,355	31,405	40,355	31,363	40,145	33,215
X₂	29,911	31,380	29,911	31,380	29,980	31,425	29,731

Procedures and Methods

Short-circuit calculations on a single-phase center tapped transformer system require a slightly different procedure than 3Ø faults on 3Ø systems.

1. It is necessary that the proper impedance be used to represent the primary system. For 3Ø fault calculations, a single primary conductor impedance is only considered from the source to the transformer connection. This is compensated for in the 3Ø short-circuit formula by multiplying the single conductor or single-phase impedance by 1.73.

However, for single-phase faults, a primary conductor impedance is considered from the source to the transformer and back to the source. This is compensated in the calculations by multiplying the 3Ø primary source impedance by two.

2. The impedance of the center-tapped transformer must be adjusted for the half-winding (generally line-to-neutral) fault condition.

The diagram at the right illustrates that during line-to-neutral faults, the full primary winding is involved but, only the half-winding on the secondary is involved. Therefore, the actual transformer reactance and resistance of the half-winding condition is different than the actual transformer reactance and resistance of the full winding condition. Thus, adjustment to the %X and %R must be made when considering line-to-neutral faults. The adjustment multipliers generally used for this condition are as follows:

- 1.5 times full winding %R on full winding basis.
- 1.2 times full winding %X on full winding basis.

Note: %R and %X multipliers given in Table 1.3 may be used, however, calculations must be adjusted to indicate transformer KVA/2.

3. The impedance of the cable and two-pole switches on the system must be considered "both-ways" since the current flows to the fault and then returns to the source. For instance, if a line-to-line fault occurs 50 feet from a transformer, then 100 feet of cable impedance must be included in the calculation.

The calculations on the following pages illustrate 1Ø fault calculations on a single-phase transformer system. Both line-to-line and line-to-neutral faults are considered.

Note in these examples:

- a. The multiplier of 2 for some electrical components to account for the single-phase fault current flow,
- b. The half-winding transformer %X and %R multipliers for the line-to-neutral fault situation, and
- c. The KVA and voltage bases used in the per-unit calculations

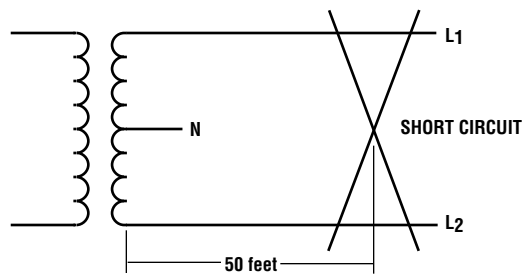
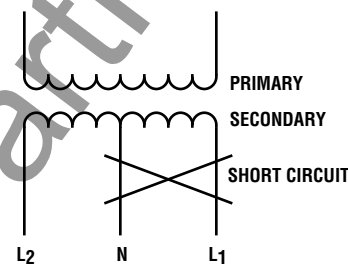
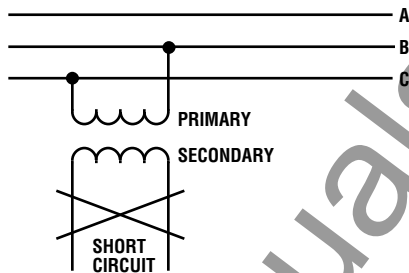

Per-Unit Method – Line-to-Line Fault @ 240V – Fault X₁

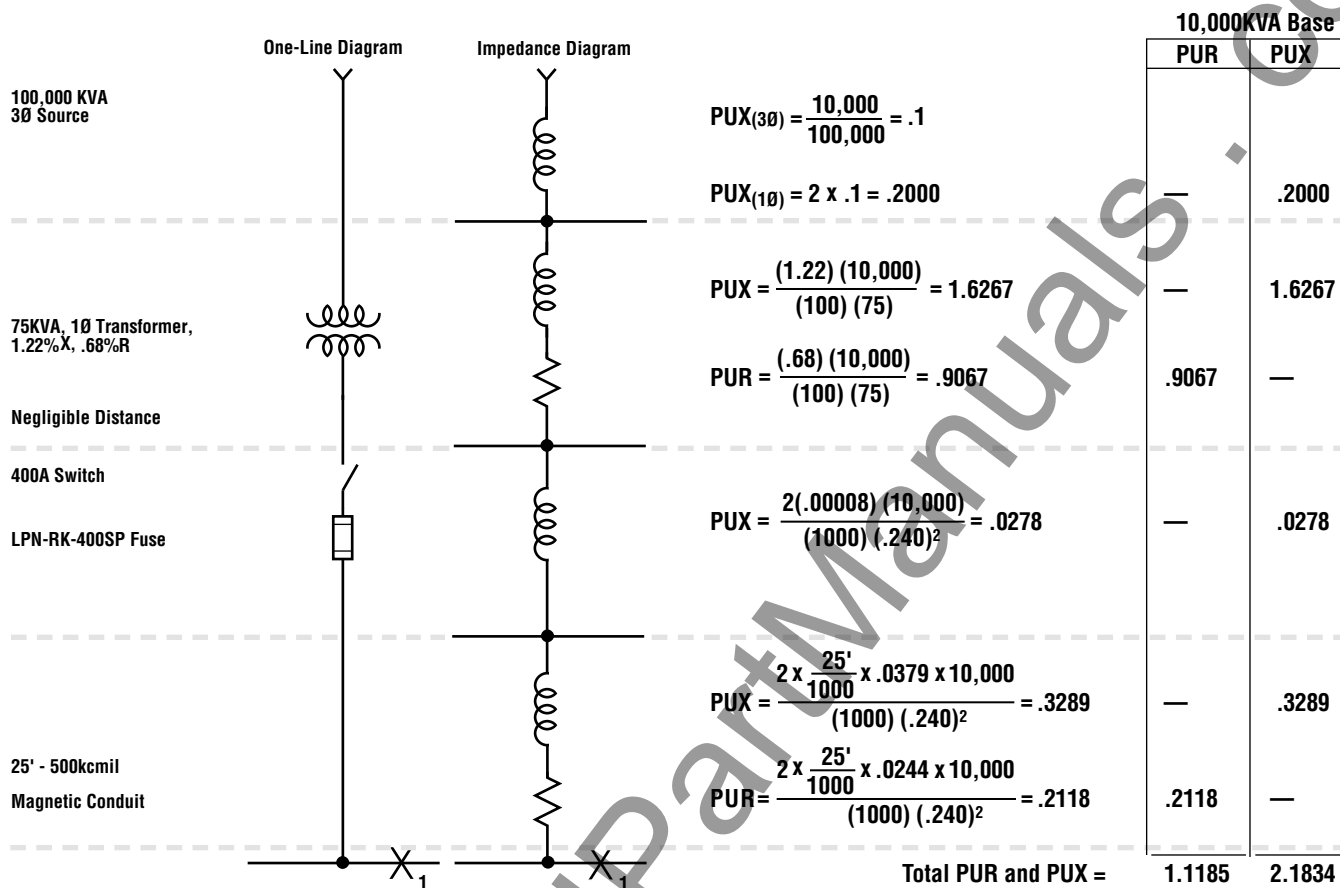

$$PUZ_{total} = \sqrt{(1.1185)^2 + (2.1834)^2} = 2.4532$$

$$I_{s.c. \text{ sym RMS}} = \frac{10,000}{(.240)(2.4532)} = 16,984A$$

L-L @ 240V

Note: See "Data Section" for impedance data for the electrical components.

Per-Unit Method – Line-to-Neutral Fault @ 120V – Fault X₁

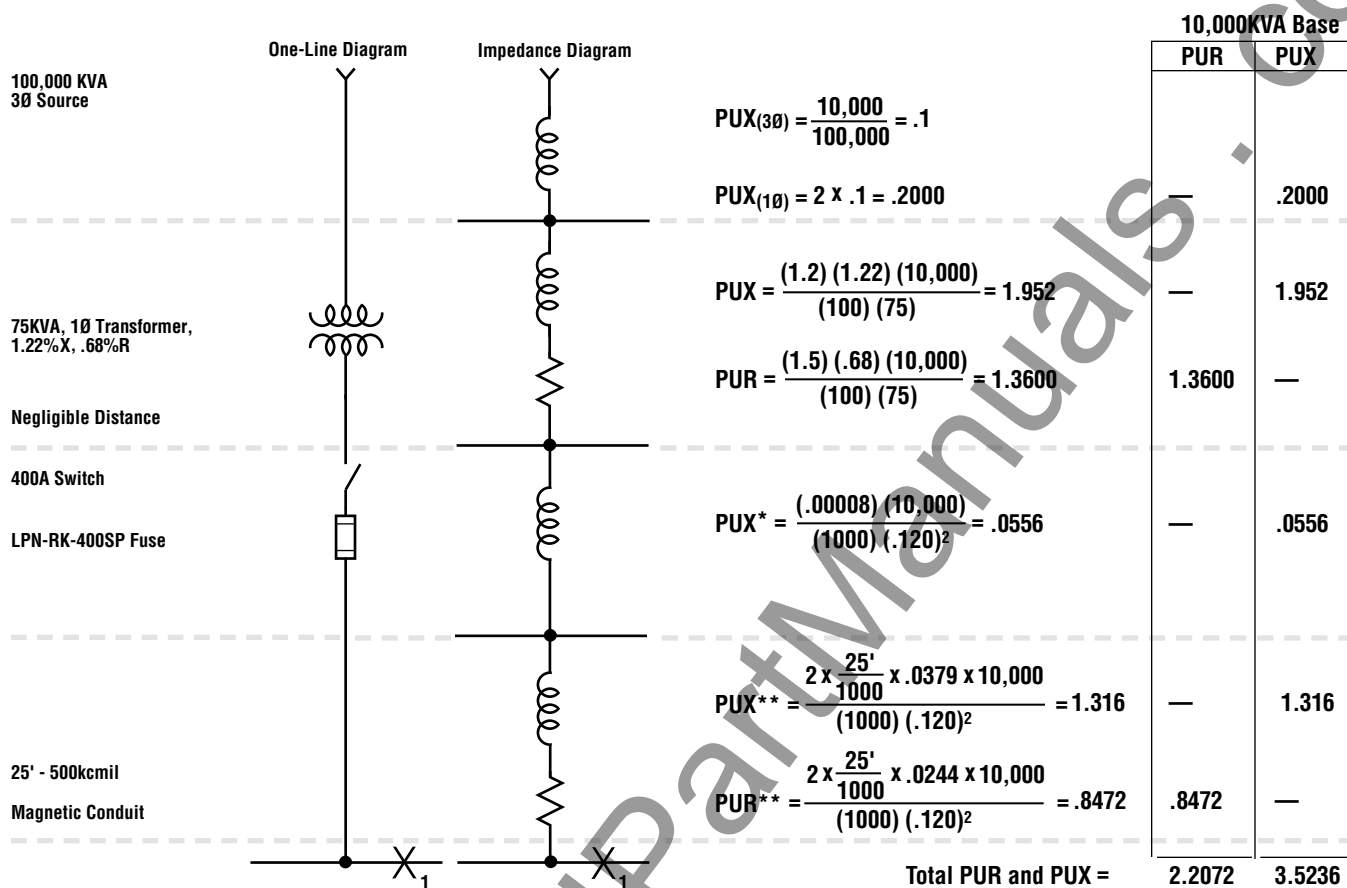

$$PUZ_{total} = \sqrt{(2.2072)^2 + (3.5236)^2} = 4.158$$

$$I_{s.c. \text{ sym RMS}} = \frac{10,000}{(.120)(4.158)} = 20,041A$$

Note: See "Data Section" for impedance data for the electrical components.

*The multiplier of two (2) is not applicable since on a line to neutral fault, only one switch pole is involved.

** Assumes the neutral conductor and the line conductor are the same size.

www.ElectricalPD.com

Point-to-Point Method – Line-to-Line Fault @ 240V – Fault X₁

Available Utility
S.C. KVA 100,000
3Ø Source

75KVA, 1Ø Transformer,
1.22%X, .68%R
1.40%Z
120/240V

Negligible Distance

400A Switch

LPN-RK-400SP Fuse

25' - 500kcmil

Magnetic Conduit

One-Line Diagram



Fault X₁

Step 1. $I_{f.l.} = \frac{75 \times 1000}{240} = 312.5A$

Step 2. Multiplier = $\frac{100}{1.40} = 71.43$

Step 3. $I_{s.c.} = 312.5 \times 71.43 = 22,322A$

Step 4. $f = \frac{2 \times 25 \times 22,322}{22,185 \times 240} = .2096$

Step 5. $M = \frac{1}{1 + .2096} = .8267$

Step 6. $I_{s.c. L-L (X_1)} = 22,322 \times .8267 = 18,453A$

www.ElectricalPartManuals.com

Point-to-Point Method – Line-to-Neutral Fault @ 120V – Fault X₁

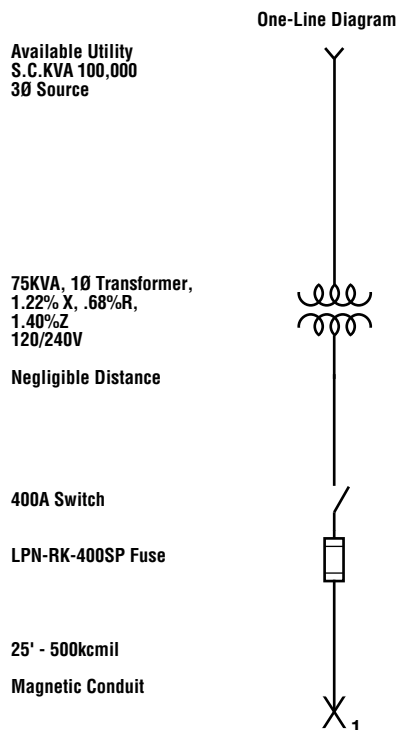

Fault X₁

Step 1. $I_{f.l.} = \frac{75 \times 1000}{240} = 312.5A$

Step 2. **Multiplier** = $\frac{100}{1.40} = 71.43$

Step 3. $I_{s.c. (L-L)} = 312.5 \times 71.43 = 22,322A$

$I_{s.c. (L-N)} = 22,322 \times 1.5 = 33,483A$

Step 4. $f = \frac{2' \times 25 \times 22,322 \times 1.5}{22,185 \times 120} = .6288$

Step 5. $M = \frac{1}{1 + .6288} = .6139$

Step 6. $I_{s.c. L-N (X_1)} = 33,483 \times .6139 = 20,555A$

* Assumes the Neutral conductor and the line conductor are the same size.

Comparison of Results

Per-Unit Method vs. Point-to-Point Method

	Per-Unit Method	PTP Method
X₁		
Line-Line	16,984A	18,453A
Line-Neutral	20,041A	20,555A

Impedance and Reactance Data—Transformers and Switches

Table 1.1. Transformer Impedance Data (X/R Ratio of Transformers – Based on ANSI/IEEE C37.010-1979)



This table has been reprinted from IEEE Std 141-1986, IEEE Recommended Practice for Electric Power Distribution for Industrial Plants, Copyright© 1986 by the Institute of Electrical and Electronics Engineers, Inc with the permission of the IEEE Standards Department.

Table 1.2. Impedance Data for Three Phase Transformers

KVA	%R	%X	%Z	X/R
3.0	3.7600	1.0000	3.8907	0.265
6.0	2.7200	1.7200	3.2182	0.632
9.0	2.3100	1.1600	2.5849	0.502
15.0	2.1000	1.8200	2.7789	0.867
30.0	0.8876	1.3312	1.6000	1.5
45.0	0.9429	1.4145	1.7000	1.5
75.0	0.8876	1.3312	1.6000	1.5
112.5	0.5547	0.8321	1.0000	1.5
150.0	0.6657	0.9985	1.2000	1.5
225.0	0.6657	0.9985	1.2000	1.5
300.0	0.6657	0.9985	1.2000	1.5
500.0	0.7211	1.0816	1.3000	1.5
750.0	0.6317	3.4425	3.5000	5.45
1000.0	0.6048	3.4474	3.5000	5.70
1500.0	0.5617	3.4546	3.5000	6.15
2000.0	0.7457	4.9441	5.0000	6.63
2500.0	0.7457	4.9441	5.0000	6.63

Note: UL Listed transformers 25KVA and greater have a ±10% tolerance on their nameplate impedance.

Table 1.3. Impedance Data for Single Phase Transformers

kVA	Suggested X/R Ratio for Calculation	Normal Range of Percent Impedance (%Z)*	Impedance Multipliers** For Line-to-Neutral Faults	
			for %X	for %R
25.0	1.1	1.2-6.0	0.6	0.75
37.5	1.4	1.2-6.5	0.6	0.75
50.0	1.6	1.2-6.4	0.6	0.75
75.0	1.8	1.2-6.6	0.6	0.75
100.0	2.0	1.3-5.7	0.6	0.75
167.0	2.5	1.4-6.1	1.0	0.75
250.0	3.6	1.9-6.8	1.0	0.75
333.0	4.7	2.4-6.0	1.0	0.75
500.0	5.5	2.2-5.4	1.0	0.75

* National standards do not specify %Z for single-phase transformers. Consult manufacturer for values to use in calculation.

** Based on rated current of the winding (one-half nameplate kVA divided by secondary line-to-neutral voltage).

Note: UL Listed transformers 25 KVA and greater have a ± 10% tolerance on their impedance nameplate.

This table has been reprinted from IEEE Std 242-1986 (R1991), IEEE Recommended Practice for Protection and Coordination of Industrial and Commercial Power Systems, Copyright© 1986 by the Institute of Electrical and Electronics Engineers, Inc. with the permission of the IEEE Standards Department.

Table 1.4. Impedance Data for Single Phase and Three Phase Transformers-Supplement†

KVA	%Z	Suggested X/R Ratio for Calculation
10	1.2	1.1
15	1.3	1.1
75	1.11	1.5
150	1.07	1.5
225	1.12	1.5
300	1.11	1.5
333	1.9	4.7
500	2.1	5.5

† These represent actual transformer nameplate ratings taken from field installations.

Note: UL Listed transformers 25KVA and greater have a ±10% tolerance on their impedance nameplate.

Table 2. Current Transformer Reactance Data Approximate Reactance of Current Transformers*

Primary Current Ratings - Amperes	Reactance in Ohms for Various Voltage Ratings		
	600-5000V	7500V	15,000V
100 - 200	0.0022	0.0040	—
250 - 400	0.0005	0.0008	0.0002
500 - 800	0.00019	0.00031	0.00007
1000 - 4000	0.00007	0.00007	0.00007

Note: Values given are in ohms per phase. For actual values, refer to manufacturers' data.

This table has been reprinted from IEEE Std 241-1990, IEEE Recommended Practice for Commercial Building Power Systems, Copyright© 1990 by the Institute of Electrical and Electronics Engineers, Inc. with the permission of the IEEE Standards Department.

Table 3. Disconnecting Switch Reactance Data (Disconnecting-Switch Approximate Reactance Data, in Ohms*)

Switch Size (Amperes)	Reactance (Ohms)
200	0.0001
400	0.00008
600	0.00008
800	0.00007
1200	0.00007
1600	0.00005
2000	0.00005
3000	0.00004
4000	0.00004

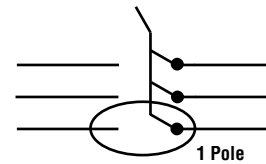

Note: The reactance of disconnecting switches for low-voltage circuits (600V and below) is in the order of magnitude of 0.00008 - 0.00005 ohm/pole at 60 Hz for switches rated 400 - 4000 A, respectively.

*For actual values, refer to manufacturers' data.

This table has been reprinted from IEEE Std 241-1990, IEEE Recommended Practice for Commercial Building Power Systems, Copyright© 1990 by the Institute of Electrical and Electronics Engineers, Inc. with the permission of the IEEE Standards Department.

Impedance & Reactance Data - Circuit Breakers and Conductors

Table 4. Circuit Breaker Reactance Data

(a) Reactance of Low-Voltage Power Circuit Breakers

Circuit-Breaker		
Interrupting Rating (amperes)	Circuit-Breaker Rating (amperes)	Reactance (ohms)
15,000	15 - 35	0.04
and	50 - 100	0.004
25,000	125 - 225	0.001
	250 - 600	0.0002
50,000	200 - 800	0.0002
	1000 - 1600	0.00007
75,000	2000 - 3000	0.00008
100,000	4000	0.00008

(b) Typical Molded Case Circuit Breaker Impedances

Molded-Case Circuit-Breaker		
Rating (amperes)	Resistance (ohms)	Reactance (ohms)
20	0.00700	Negligible
40	0.00240	Negligible
100	0.00200	0.00070
225	0.00035	0.00020
400	0.00031	0.00039
600	0.00007	0.00017

Notes:

(1) Due to the method of rating low-voltage power circuit breakers, the reactance of the circuit breaker which is to interrupt the fault is not included in calculating fault current.

(2) Above 600 amperes the reactance of molded case circuit breakers are similar to those given in (a)

*For actual values, refer to manufacturers' data.

This table has been reprinted from IEEE Std 241-1990, IEEE Recommended Practice for Commercial Building Power Systems, copyright © 1990 by the Institute of Electrical and Electronics Engineers, Inc. with the permission of the IEEE Standards Department.

Table 5. Impedance Data - Insulated Conductors (Ohms/1000 ft. each conductor - 60Hz)

Size AWG or kcm	Resistance (25C)				Reactance - 600V - THHN			
	Copper		Aluminum		Single Conductors		1 Multiconductor	
	Metal	NonMet	Metal	Nonmet	Mag.	Nonmag.	Mag.	Nonmag.
14	2.5700	2.5700	4.2200	4.2200	.0493	.0394	.0351	.0305
12	1.6200	1.6200	2.6600	2.6600	.0468	.0374	.0333	.0290
10	1.0180	1.0180	1.6700	1.6700	.0463	.0371	.0337	.0293
8	.6404	.6404	1.0500	1.0500	.0475	.0380	.0351	.0305
6	.4100	.4100	.6740	.6740	.0437	.0349	.0324	.0282
4	.2590	.2590	.4240	.4240	.0441	.0353	.0328	.0235
2	.1640	.1620	.2660	.2660	.0420	.0336	.0313	.0273
1	.1303	.1290	.2110	.2110	.0427	.0342	.0319	.0277
1/0	.1040	.1020	.1680	.1680	.0417	.0334	.0312	.0272
2/0	.0835	.0812	.1330	.1330	.0409	.0327	.0306	.0266
3/0	.0668	.0643	.1060	.1050	.0400	.0320	.0300	.0261
4/0	.0534	.0511	.0844	.0838	.0393	.0314	.0295	.0257
250	.0457	.0433	.0722	.0709	.0399	.0319	.0299	.0261
300	.0385	.0362	.0602	.0592	.0393	.0314	.0295	.0257
350	.0333	.0311	.0520	.0507	.0383	.0311	.0290	.0254
400	.0297	.0273	.0460	.0444	.0385	.0308	.0286	.0252
500	.0244	.0220	.0375	.0356	.0379	.0303	.0279	.0249
600	.0209	.0185	.0319	.0298	.0382	.0305	.0278	.0250
750	.0174	.0185	.0264	.0240	.0376	.0301	.0271	.0247
1000	.0140	.0115	.0211	.0182	.0370	.0296	.0260	.0243

Note: Increased resistance of conductors in magnetic raceway is due to the effect of hysteresis losses. The increased resistance of conductors in metal non-magnetic raceway is due to the effect of eddy current losses. The effect is essentially equal for steel and aluminum raceway. Resistance values are acceptable for 600 volt, 5KV and 15 KV insulated Conductors.

Size AWG or kcm	Reactance - 5KV				Reactance - 15KV			
	Single Conductors		1 Multiconductor		Single Conductors		1 Multiconductor	
	Mag.	Nonmag.	Mag.	Nonmag.	Mag.	Nonmag.	Mag.	Nonmag.
8	.0733	.0586	.0479	.0417	-	-	-	-
6	.0681	.0545	.0447	.0389	.0842	.0674	.0584	.0508
4	.0633	.0507	.0418	.0364	.0783	.0626	.0543	.0472
2	.0591	.0472	.0393	.0364	.0727	.0582	.0505	.0439
1	.0571	.0457	.0382	.0332	.0701	.0561	.0487	.0424
1/0	.0537	.0430	.0360	.0313	.0701	.0561	.0487	.0424
2/0	.0539	.0431	.0350	.0305	.0661	.0561	.0458	.0399
3/0	.0521	.0417	.0341	.0297	.0614	.0529	.0427	.0372
4/0	.0505	.0404	.0333	.0290	.0592	.0491	.0413	.0359
250	.0490	.0392	.0323	.0282	.0573	.0474	.0400	.0348
300	.0478	.0383	.0317	.0277	.0557	.0458	.0387	.0339
350	.0469	.0375	.0312	.0274	.0544	.0446	.0379	.0332
400	.0461	.0369	.0308	.0270	.0534	.0436	.0371	.0326
500	.0461	.0369	.0308	.0270	.0517	.0414	.0357	.0317
600	.0439	.0351	.0296	.0261	.0516	.0414	.0343	.0309
750	.0434	.0347	.0284	.0260	.0500	.0413	.0328	.0301
1000	.0421	.0337	.0272	.0255	.0487	.0385	.0311	.0291

These are only representative figures. Reactance is affected by cable insulation type, shielding, conductor outside diameter, conductor spacing in 3 conductor cable, etc. In commercial buildings medium voltage impedances normally do not affect the short circuit calculations significantly.

This table has been reprinted from IEEE Std 241-1990, IEEE Recommended Practice for Commercial Building Power Systems, copyright © 1990 by the Institute of Electrical and Electronics Engineers, Inc. with the permission of the IEEE Standards Department.

"C" Values for Conductors and Busway

Table 6. "C" Values for Conductors and Busway

Copper												
AWG or kcmil	Three Single Conductors Conduit						Three-Conductor Cable Conduit					
	Steel			Nonmagnetic			Steel			Nonmagnetic		
	600V	5KV	15KV	600V	5KV	15KV	600V	5KV	15KV	600V	5KV	15KV
14	389	389	389	389	389	389	389	389	389	389	389	389
12	617	617	617	617	617	617	617	617	617	617	617	617
10	981	981	981	981	981	981	981	981	981	981	981	981
8	1557	1551	1557	1558	1555	1558	1559	1557	1559	1559	1558	1559
6	2425	2406	2389	2430	2417	2406	2431	2424	2414	2438	2428	2420
4	3806	3750	3695	3825	3789	3752	3830	3811	3778	3837	3823	3798
3	4760	4760	4760	4802	4802	4802	4760	4790	4760	4802	4802	4802
2	5906	5736	5574	6044	5926	5809	5989	5929	5827	6087	6022	5957
1	7292	7029	6758	7493	7306	7108	7454	7364	7188	7579	7507	7364
1/0	8924	8543	7973	9317	9033	8590	9209	9086	8707	9472	9372	9052
2/0	10755	10061	9389	11423	10877	10318	11244	11045	10500	11703	11528	11052
3/0	12843	11804	11021	13923	13048	12360	13656	13333	12613	14410	14118	13461
4/0	15082	13605	12542	16673	15351	14347	16391	15890	14813	17482	17019	16012
250	16483	14924	13643	18593	17120	15865	18310	17850	16465	19779	19352	18001
300	18176	16292	14768	20867	18975	17408	20617	20051	18318	22524	21938	20163
350	19703	17385	15678	22736	20526	18672	19557	21914	19821	22736	24126	21982
400	20565	18235	16365	24296	21786	19731	24253	23371	21042	26915	26044	23517
500	22185	19172	17492	26706	23277	21329	26980	25449	23125	30028	28712	25916
600	22965	20567	17962	28033	25203	22097	28752	27974	24896	32236	31258	27766
750	24136	21386	18888	28303	25430	22690	31050	30024	26932	32404	31338	28303
1000	25278	22539	19923	31490	28083	24887	33864	32688	29320	37197	35748	31959
Aluminum												
14	236	236	236	236	236	236	236	236	236	236	236	236
12	375	375	375	375	375	375	375	375	375	375	375	375
10	598	598	598	598	598	598	598	598	598	598	598	598
8	951	950	951	951	950	951	951	951	951	951	951	951
6	1480	1476	1472	1481	1478	1476	1481	1480	1478	1482	1481	1479
4	2345	2332	2319	2350	2341	2333	2351	2347	2339	2353	2349	2344
3	2948	2948	2948	2958	2958	2958	2948	2956	2948	2958	2958	2958
2	3713	3669	3626	3729	3701	3672	3733	3719	3693	3739	3724	3709
1	4645	4574	4497	4678	4631	4580	4686	4663	4617	4699	4681	4646
1/0	5777	5669	5493	5838	5766	5645	5852	5820	5717	5875	5851	5771
2/0	7186	6968	6733	7301	7152	6986	7327	7271	7109	7372	7328	7201
3/0	8826	8466	8163	9110	8851	8627	9077	8980	8750	9242	9164	8977
4/0	10740	10167	9700	11174	10749	10386	11184	11021	10642	11408	11277	10968
250	12122	11460	10848	12862	12343	11847	12796	12636	12115	13236	13105	12661
300	13909	13009	12192	14922	14182	13491	14916	14698	13973	15494	15299	14658
350	15484	14280	13288	16812	15857	14954	15413	16490	15540	16812	17351	16500
400	16670	15355	14188	18505	17321	16233	18461	18063	16921	19587	19243	18154
500	18755	16827	15657	21390	19503	18314	21394	20606	19314	22987	22381	20978
600	20093	18427	16484	23451	21718	19635	23633	23195	21348	25750	25243	23294
750	21766	19685	17686	23491	21769	19976	26431	25789	23750	25682	25141	23491
1000	23477	21235	19005	28778	26109	23482	29864	29049	26608	32938	31919	29135

Note: These values are equal to one over the impedance per foot for impedances found in Table 5, Page 26.

Ampacity	Busway				
	Plug-In Copper	Feeder		High Impedance	
		Aluminum	Copper	Aluminum	Copper
225	28700	23000	18700	12000	—
400	38900	34700	23900	21300	—
600	41000	38300	36500	31300	—
800	46100	57500	49300	44100	—
1000	69400	89300	62900	56200	15600
1200	94300	97100	76900	69900	16100
1350	119000	104200	90100	84000	17500
1600	129900	120500	101000	90900	19200
2000	142900	135100	134200	125000	20400
2500	143800	156300	180500	166700	21700
3000	144900	175400	204100	188700	23800
4000	—	—	277800	256400	—

Note: These values are equal to one over the impedance per foot for impedances in Table 7, Page 28.

Busway Impedance Data

Table 7. Busway Impedance Data (Ohms per 1000 Feet – Line-to-Neutral, 60 Cycles)

Plug-In Busway						
Ampere Rating	Copper Bus Bars			Aluminum Bus Bars		
	Resistance	Reactance	Impedance	Resistance	Reactance	Impedance
225	0.0262	0.0229	0.0348	0.0398	0.0173	0.0434
400	0.0136	0.0218	0.0257	0.0189	0.0216	0.0288
600	0.0113	0.0216	0.0244	0.0179	0.0190	0.0261
800	0.0105	0.0190	0.0217	0.0120	0.0126	0.0174
1000	0.0071	0.0126	0.0144	0.0080	0.0080	0.0112
1200	0.0055	0.0091	0.0106	0.0072	0.0074	0.0103
1350	0.0040	0.0072	0.0084	0.0065	0.0070	0.0096
1600	0.0036	0.0068	0.0077	0.0055	0.0062	0.0083
2000	0.0033	0.0062	0.0070	0.0054	0.0049	0.0074
2500	0.0032	0.0062	0.0070	0.0054	0.0034	0.0064
3000	0.0031	0.0062	0.0069	0.0054	0.0018	0.0057
4000	0.0030	0.0062	0.0069	—	—	—
5000	0.0020	0.0039	0.0044	—	—	—
Low-Impedance Feeder Busway						
225	0.0425	0.0323	0.0534	0.0767	0.0323	0.0832
400	0.0291	0.0301	0.0419	0.0378	0.0280	0.0470
600	0.0215	0.0170	0.0274	0.0305	0.0099	0.0320
800	0.0178	0.0099	0.0203	0.0212	0.0081	0.0227
1000	0.0136	0.0082	0.0159	0.0166	0.0065	0.0178
1200	0.0110	0.0070	0.0130	0.0133	0.0053	0.0143
1350	0.0090	0.0065	0.0111	0.0110	0.0045	0.0119
1600	0.0083	0.0053	0.0099	0.0105	0.0034	0.0110
2000	0.0067	0.0032	0.0074	0.0075	0.0031	0.0080
2500	0.0045	0.0032	0.0055	0.0055	0.0023	0.0060
3000	0.0041	0.0027	0.0049	0.0049	0.0020	0.0053
4000	0.0030	0.0020	0.0036	0.0036	0.0015	0.0039
5000	0.0023	0.0015	0.0027	—	—	—

The above data represents values which are a composite of those obtained by a survey of industry; values tend to be on the low side.

Asymmetrical Factors

Table 8. Asymmetrical Factors

Short Circuit Power Factor, Percent*	Short Circuit X/R Ratio	Ratio to Symmetrical RMS Amperes		
		Maximum 1 phase Instantaneous Peak Amperes Mp	Maximum 1 phase RMS Amperes at 1/2 Cycle M _m (Asym.Factor)*	Average 3 phase RMS Amperes at 1/2 Cycle M _a *
0	∞	2.828	1.732	1.394
1	100.00	2.785	1.697	1.374
2	49.993	2.743	1.662	1.354
3	33.322	2.702	1.630	1.336
4	24.979	2.663	1.599	1.318
5	19.974	2.625	1.569	1.302
6	16.623	2.589	1.540	1.286
7	14.251	2.554	1.512	1.271
8	13.460	2.520	1.486	1.256
9	11.066	2.487	1.461	1.242
10	9.9301	2.455	1.437	1.229
11	9.0354	2.424	1.413	1.216
12	8.2733	2.394	1.391	1.204
13	7.6271	2.364	1.370	1.193
14	7.0721	2.336	1.350	1.182
15	6.5912	2.309	1.331	1.172
16	6.1695	2.282	1.312	1.162
17	5.7947	2.256	1.295	1.152
18	5.4649	2.231	1.278	1.144
19	5.16672	2.207	1.278	1.135
20	4.8990	2.183	1.247	1.127
21	4.6557	2.160	1.232	1.119
22	4.4341	2.138	1.219	1.112
23	4.2313	2.110	1.205	1.105
24	4.0450	2.095	1.193	1.099
25	3.8730	2.074	1.181	1.092
26	3.7138	2.054	1.170	1.087
27	3.5661	2.034	1.159	1.081
28	3.4286	2.015	1.149	1.076
29	3.3001	1.996	1.139	1.071
30	3.1798	1.978	1.130	1.064
31	3.0669	1.960	1.122	1.062
32	2.9608	1.943	1.113	1.057
33	2.8606	1.926	1.106	1.057
34	2.7660	1.910	1.098	1.050
35	2.6764	1.894	1.091	1.046
36	2.5916	1.878	1.085	1.043
37	2.5109	1.863	1.079	1.040
38	2.4341	1.848	1.073	1.037
39	2.3611	1.833	1.068	1.034
40	2.2913	1.819	1.062	1.031
41	2.2246	1.805	1.058	1.029
42	2.1608	1.791	1.053	1.027
43	2.0996	1.778	1.049	1.024
44	2.0409	1.765	1.045	1.023
45	1.9845	1.753	1.041	1.021
46	1.9303	1.740	1.038	1.019
47	1.8780	1.728	1.035	1.017
48	1.8277	1.716	1.032	1.016
49	1.7791	1.705	1.029	1.014
50	1.7321	1.694	1.026	1.013
55	1.5185	1.641	1.016	1.008
60	1.3333	1.594	1.009	1.004
65	1.1691	1.517	1.005	1.001
70	1.0202	1.517	1.002	1.001
75	0.8819	1.486	1.0008	1.0004
80	0.7500	1.460	1.0002	1.0001
85	0.6198	1.439	1.00004	1.00002
100	0.0000	1.414	1.00000	1.00000

*Reprinted by permission of National Electrical Manufacturer's Association from NEMA Publication AB-1, 1986, copyright 1986 by NEMA.

Selective Coordination (Blackout Prevention)

Having determined the faults that must be interrupted, the next step is to specify Protective Devices that will provide a Selectively Coordinated System with proper Interrupting Ratings.

Such a system assures safety and reliability under all service conditions and prevents needless interruption of service on circuits other than the one on which a fault occurs.

The topic of Selectivity will be Discussed in the next Handbook, EDP II.

Component Protection (Equipment Damage Prevention)

Proper protection of electrical equipment requires that fault current levels be known. The characteristics and let-through values of the overcurrent device must be known, and compared to the equipment withstand ratings. This topic of Component Protection is discussed in the third Handbook, EDP III.