

# SIEMENS

## MICROMASTER 440

0.12 kW - 250 kW

Operating Instructions

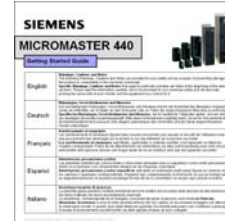
Issue 10/06



# MICROMASTER 440 Documentation

## Getting Started Guide

Is for quick commissioning with SDP and BOP.



## Operating Instructions

Gives information about features of the MICROMASTER 440, Installation, Commissioning, Control modes, System Parameter structure, Troubleshooting, Specifications and available options of the MICROMASTER 440.



## Parameter List

The Parameter List contains the description of all Parameters structured in functional order and a detailed description. The Parameter list also includes a series of function plans.



## Catalogues

In the catalogue you will find all the necessary information to select an appropriate inverter, as well as filters, chokes, operator panels and communication options.



# SIEMENS

## MICROMASTER 440

0.12 kW - 250 kW

**Operating Instructions**  
User Documentation

**Valid for**

Issue 10/06

*Inverter Type*  
MICROMASTER 440  
0.12 kW - 250 kW

*Software Version*  
2.1

**Issue 10/06**

<b>Overview</b>	<b>1</b>
<b>Installation</b>	<b>2</b>
<b>Functions</b>	<b>3</b>
<b>Troubleshooting</b>	<b>4</b>
<b>Specifications</b>	<b>5</b>
<b>Options</b>	<b>6</b>
<b>Electro-Magnetic Compatibility</b>	<b>7</b>
<b>Appendices</b>	<b>A B C D E F G</b>
<b>Index</b>	

Further information can be obtained from Internet website:

<http://www.siemens.de/micromaster>

Approved Siemens Quality for Software and Training is to DIN ISO 9001, Reg. No. 2160-01

The reproduction, transmission or use of this document, or its contents is not permitted unless authorized in writing. Offenders will be liable for damages. All rights including rights created by patent grant or registration of a utility model or design are reserved.

© Siemens AG 2001 – 2005, 2006. All Rights Reserved.

MICROMASTER® is a registered trademark of Siemens

Other functions not described in this document may be available. However, this fact shall not constitute an obligation to supply such functions with a new control, or when servicing.

We have checked that the contents of this document correspond to the hardware and software described. There may be discrepancies nevertheless, and no guarantee can be given that they are completely identical. The information contained in this document is reviewed regularly and any necessary changes will be included in the next edition. We welcome suggestions for improvement.

Siemens handbooks are printed on chlorine-free paper that has been produced from managed sustainable forests. No solvents have been used in the printing or binding process.

Document subject to change without prior notice.

---

Order number: 6SE6400-5AW00-0BP0

Siemens-Aktiengesellschaft

## Foreword

### User Documentation

---

**WARNING**

Before installing and commissioning the inverter, you must read all safety instructions and warnings carefully including all the warning labels attached to the equipment. Make sure that the warning labels are kept in a legible condition and replace missing or damaged labels.

---

### Information is also available from:

#### Regional Contacts

Please get in touch with your contact for Technical Support in your Region for questions about services, prices and conditions of Technical Support.

#### Central Technical Support

The competent consulting service for technical issues with a broad range of requirements-based services around our products and systems.

**Europe / Africa**

Tel: +49 (0) 180 5050 222

Fax: +49 (0) 180 5050 223

Email: [adsupport@siemens.com](mailto:adsupport@siemens.com)

**America**

Tel: +1 423 262 2522

Fax: +1 423 262 2589

Email: [simatic.hotline@sea.siemens.com](mailto:simatic.hotline@sea.siemens.com)

**Asia / Pazific**

Tel: +86 1064 757 575

Fax: +86 1064 747 474

Email: [adsupport.asia@siemens.com](mailto:adsupport.asia@siemens.com)

#### Online Service & Support

The comprehensive, generally available information system over the Internet, from product support to service & support to the support tools in the shop.

<http://www.siemens.com/automation/service&support>

#### Contact address

Should any questions or problems arise while reading this manual, please contact the Siemens office concerned using the form provided at the back this manual.

## Definitions and Warnings



### **DANGER**

indicates an imminently hazardous situation which, if not avoided, will result in death or serious injury.



### **WARNING**

indicates a potentially hazardous situation which, if not avoided, could result in death or serious injury.



### **CAUTION**

used with the safety alert symbol indicates a potentially hazardous situation which, if not avoided, may result in minor or moderate injury.

### **CAUTION**

used without safety alert symbol indicates a potentially hazardous situation which, if not avoided, may result in a property damage.

### **NOTICE**

indicates a potential situation which, if not avoided, may result in an undesirable result or state.

### **NOTE**

For the purpose of this documentation, "Note" indicates important information relating to the product or highlights part of the documentation for special attention.

### **Qualified personnel**

For the purpose of this Instruction Manual and product labels, a "Qualified person" is someone who is familiar with the installation, mounting, start-up and operation of the equipment and the hazards involved.

He or she must have the following qualifications:


1. Trained and authorized to energize, de-energize, clear, ground and tag circuits and equipment in accordance with established safety procedures.
2. Trained in the proper care and use of protective equipment in accordance with established safety procedures.
3. Trained in rendering first aid.

PE



= Ground

- ◆ PE – Protective Earth uses circuit protective conductors sized for short circuits where the voltage will not rise in excess of 50 Volts. This connection is normally used to ground the inverter.

- ◆  - Is the ground connection where the reference voltage can be the same as the Earth voltage. This connection is normally used to ground the motor.

### **Use for intended purpose only**

The equipment may be used only for the application stated in the manual and only in conjunction with devices and components recommended and authorized by Siemens.

## Safety Instructions

The following Warnings, Cautions and Notes are provided for your safety and as a means of preventing damage to the product or components in the machines connected. This section lists Warnings, Cautions and Notes, which apply generally when handling MICROMASTER 440 Inverters, classified as **General, Transport & Storage, Commissioning, Operation, Repair and Dismantling & Disposal**.

**Specific Warnings, Cautions and Notes** that apply to particular activities are listed at the beginning of the relevant chapters and are repeated or supplemented at critical points throughout these sections.

**Please read the information carefully, since it is provided for your personal safety and will also help prolong the service life of your MICROMASTER 440 Inverter and the equipment you connect to it.**

### General



#### WARNING

- This equipment contains dangerous voltages and controls potentially dangerous rotating mechanical parts. Non-compliance with **Warnings** or failure to follow the instructions contained in this manual can result in loss of life, severe personal injury or serious damage to property.
- Only suitable qualified personnel should work on this equipment, and only after becoming familiar with all safety notices, installation, operation and maintenance procedures contained in this manual. The successful and safe operation of this equipment is dependent upon its proper handling, installation, operation and maintenance.
- Risk of electric shock. The DC link capacitors remain charged for five minutes after power has been removed. **It is not permissible to open the equipment until 5 minutes after the power has been removed.**  
The following terminals can carry dangerous voltages even if the inverter is inoperative:
  - ◆ the power supply L/L1, N/L2, L3 resp. U1/L1, V1/L2, W1/L3
  - ◆ the motor terminals U, V, W resp. U2, V2, W2
  - ◆ and depending on the frame size the terminals DC+/B+, DC-, B-, DC/R+ resp. DCPS, DCNS, DCPA, DCNA
- **HP ratings are based on the Siemens 1LA motors and are given for guidance only; they do not necessarily comply with UL or NEMA HP ratings.**



#### CAUTION

- Children and the general public must be prevented from accessing or approaching the equipment!
- This equipment may only be used for the purpose specified by the manufacturer. Unauthorized modifications and the use of spare parts and accessories that are not sold or recommended by the manufacturer of the equipment can cause fires, electric shocks and injuries.

**NOTICE**

- Keep these operating instructions within easy reach of the equipment and make them available to all users
- Whenever measuring or testing has to be performed on live equipment, the regulations of Safety Code BGV A2 must be observed, in particular §8 "Permissible Deviations when Working on Live Parts". Suitable electronic tools should be used.
- Before installing and commissioning, please read these safety instructions and warnings carefully and all the warning labels attached to the equipment. Make sure that the warning labels are kept in a legible condition and replace missing or damaged labels.

**Transport & Storage****WARNING**

Correct transport, storage, erection and mounting, as well as careful operation and maintenance are essential for proper and safe operation of the equipment.

**CAUTION**

Protect the inverter against physical shocks and vibration during transport and storage. Also be sure to protect it against water (rainfall) and excessive temperatures (see Table 4-1).

**Commissioning****WARNING**

- Work on the device/system by **unqualified** personnel or failure to comply with warnings can result in severe personal injury or serious damage to material. Only suitably qualified personnel trained in the setup, installation, commissioning and operation of the product should carry out work on the device/system.
- Only permanently-wired input power connections are allowed. This equipment must be grounded (IEC 536 Class 1, NEC and other applicable standards).
- Only type B ELCBs should be used with FSA to FSF. Machines with a three-phase power supply, fitted with EMC filters, must not be connected to a supply via an ELCB (Earth Leakage Circuit-Breaker - see *DIN VDE 0160, section 5.5.2 and EN50178 section 5.2.11.1*).
- The following terminals can carry dangerous voltages even if the inverter is inoperative:
  - ◆ the power supply L/L1, N/L2, L3 resp. U1/L1, V1/L2, W1/L3
  - ◆ the motor terminals U, V, W resp. U2, V2, W2
  - ◆ and depending on the frame size the terminals DC+/B+, DC-, B-, DC/R+ resp. DCPS, DCNS, DCPA, DCNA
- This equipment must not be used as an 'emergency stop mechanism' (see *EN 60204, 9.2.5.4*)

**CAUTION**

The connection of power, motor and control cables to the inverter must be carried out as shown in Fig. 2-11 on page 44, to prevent inductive and capacitive interference from affecting the correct functioning of the inverter.

## Operation



### WARNING

- MICROMASTERS operate at high voltages.
- When operating electrical devices, it is impossible to avoid applying hazardous voltages to certain parts of the equipment.
- Emergency Stop facilities according to EN 60204 IEC 204 (VDE 0113) must remain operative in all operating modes of the control equipment. Any disengagement of the Emergency Stop facility must not lead to uncontrolled or undefined restart.  
Certain parameter settings may cause the inverter to restart automatically after an input power failure (e.g. automatic restart).
- Wherever faults occurring in the control equipment can lead to substantial material damage or even grievous bodily injury (i.e. potentially dangerous faults), additional external precautions must be taken or facilities provided to ensure or enforce safe operation, even when a fault occurs (e.g. independent limit switches, mechanical interlocks, etc.).
- Motor parameters must be accurately configured for motor overload protection to operate correctly.
- This equipment is capable of providing internal motor overload protection in accordance with UL508C section 42. Refer to P0610 and P0335, it is ON by default. Motor overload protection can also be provided using an external PTC or KTY84.
- This equipment is suitable for use in a circuit capable of delivering not more than 10,000 (Frame Sizes A to C) or 42,000 (Frame Sizes D to GX) symmetrical amperes (rms), for a maximum voltage of 230 V / 460 V / 575 V when protected by an H, J or K type fuse, a circuit breaker or self-protected combination motor controller (for more details see Appendix F).
- This equipment must not be used as an 'emergency stop mechanism' (see EN 60204, 9.2.5.4)

## Repair



### WARNING

- Repairs on equipment may only be carried out by **Siemens Service**, by repair centers **authorized by Siemens** or by authorized personnel who are thoroughly acquainted with all the warnings and operating procedures contained in this manual.
- Any defective parts or components must be replaced using parts contained in the relevant spare parts list.
- Disconnect the power supply before opening the equipment for access.

## Dismantling & Disposal

### CAUTION

- The inverter's packaging is re-usable. Retain the packaging for future use.
- Easy-to-release screw and snap connectors allow you to break the unit down into its component parts. You can then re-cycle these component parts, dispose of them in **accordance with local requirements or return them to the manufacturer.**



## Electrostatic Sensitive Devices (ESD)

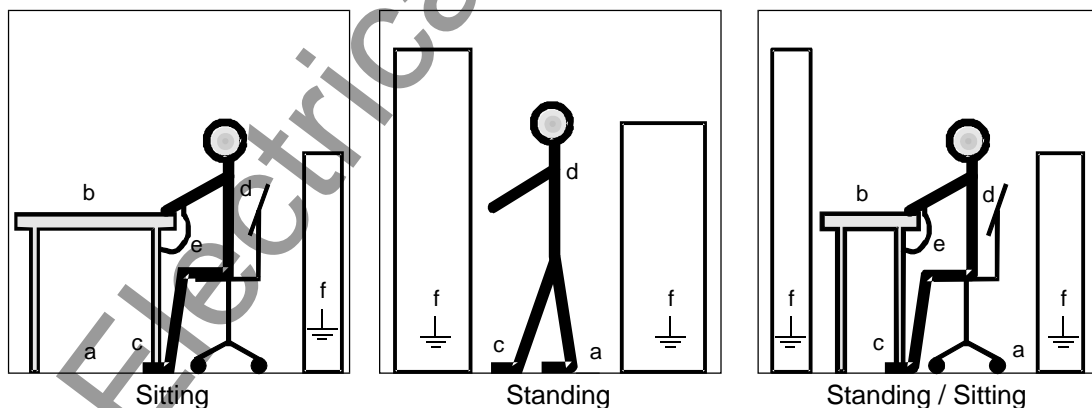
The device contains components which can be destroyed by electrostatic discharge. These components can be easily destroyed if not carefully handled. Before opening the cabinet/enclosure in which the device is located, you must electrically discharge your body and apply the appropriate ESDS protective measures. The cabinet/enclosure should be appropriately labeled.

If you have to handle electronic boards, please observe the following:

- Electronic boards should only be touched when absolutely necessary.
- The human body must be electrically discharged before touching an electronic board.
- Boards must not come into contact with highly insulating materials - e.g. plastic parts, insulated desktops, articles of clothing manufactured from man-made fibers.
- Boards must only be placed on conductive surfaces.
- Boards and components should only be stored and transported in conductive packaging (e.g. metalized plastic boxes or metal containers).
- If the packing material is not conductive, the boards must be wrapped with a conductive packaging material, e.g. conductive foam rubber or household aluminium foil.

The necessary ESD protective measures are clearly shown again in the following diagram:

- a = Conductive floor surface
- b = ESD table
- c = ESD shoes
- d = ESD overall
- e = ESD chain
- f = Cubicle ground connection



## Table of Contents

<b>1</b>	<b>Overview .....</b>	<b>17</b>
1.1	The MICROMASTER 440.....	18
1.2	Features.....	19
<b>2</b>	<b>Installation .....</b>	<b>21</b>
2.1	Installation after a Period of Storage .....	23
2.2	Ambient operating conditions .....	24
2.3	Mechanical installation.....	26
2.4	Electrical installation .....	33
<b>3</b>	<b>Functions.....</b>	<b>47</b>
3.1	Parameters .....	51
3.2	Operator panels for MICROMASTER.....	70
3.3	Block diagram .....	74
3.4	Factory setting .....	75
3.5	Commissioning .....	77
3.6	Inputs / outputs .....	135
3.7	Communications .....	144
3.8	Fixed frequencies (FF).....	167
3.9	Motorized potentiometer (MOP) .....	170
3.10	JOG.....	172
3.11	PID controller (technological controller).....	173
3.12	Setpoint channel .....	181
3.13	Free function blocks (FFB) .....	191
3.14	Motor holding brake (MHB).....	196
3.15	Electronic brakes .....	202
3.16	Automatic restart.....	211
3.17	Flying restart .....	213
3.18	Closed-loop Vdc control.....	215
3.19	Positioning down ramp .....	219
3.20	Monitoring functions / messages .....	221
3.21	Thermal motor protection and overload responses .....	227
3.22	Power module protection .....	232
3.23	Open-loop/closed-loop control technique .....	235
<b>4</b>	<b>Troubleshooting.....</b>	<b>257</b>
4.1	Troubleshooting with the SDP .....	258
4.2	Troubleshooting with the BOP .....	259

4.3	Fault messages.....	260
4.4	Alarm Messages .....	260
<b>5</b>	<b>MICROMASTER 440 specifications.....</b>	<b>261</b>
<b>6</b>	<b>Options .....</b>	<b>273</b>
6.1	Inverter-independent options .....	273
6.2	Inverter-dependent options.....	274
<b>7</b>	<b>Electro-magnetic compatibility (EMC).....</b>	<b>275</b>
7.1	Electro-magnetic compatibility .....	276
<b>Appendices .....</b>		<b>281</b>
<b>A</b>	<b>Changing the Operator Panel .....</b>	<b>281</b>
<b>B</b>	<b>Removing Front Covers .....</b>	<b>282</b>
B.1	Removing Front Covers. Frame Sizes A .....	282
B.2	Removing Front Covers. Frame Sizes B and C .....	283
B.3	Removing Front Covers. Frame Sizes D and E .....	284
B.4	Removing Front Covers. Frame Size F .....	285
B.5	Removing Front Covers. Frame Sizes FX and GX.....	286
<b>C</b>	<b>Removing the I/O Board.....</b>	<b>287</b>
<b>D</b>	<b>Removing 'Y' Cap .....</b>	<b>288</b>
D.1	Removing 'Y' Cap. Frame Size A .....	288
D.2	Removing 'Y' Cap. Frame Sizes B and C.....	289
D.3	Removing 'Y' Cap. Frame Sizes D and E.....	290
D.4	Removing 'Y' Cap. Frame Size F .....	291
D.5	Removing 'Y' Cap. Frame Size FX.....	292
D.6	Removing 'Y' Cap. Frame Size GX .....	293
<b>E</b>	<b>Removing fan.....</b>	<b>294</b>
E.1	Removing fan. Frame Size A.....	294
E.2	Removing fan. Frame Sizes B and C .....	295
E.3	Removing fan. Frame Size D and E .....	296
E.4	Removing fan. Frame Size F .....	297
E.5	Removing fan. Frame Size F with filter.....	298
E.6	Removing fan. Frame Sizes FX and GX .....	299
<b>F</b>	<b>Short circuit current rating (SCCR).....</b>	<b>300</b>
<b>G</b>	<b>Standards .....</b>	<b>301</b>
<b>H</b>	<b>List of Abbreviations .....</b>	<b>302</b>
<b>Index</b>	<b>.....</b>	<b>305</b>

## List of Illustrations

Fig. 2-1	Forming .....	23
Fig. 2-2	Ambient operating temperature .....	24
Fig. 2-3	Installation altitude.....	24
Fig. 2-4	Drill pattern for MICROMASTER 440 .....	27
Fig. 2-5	Installation dimensions for MICROMASTER 440 Frame size FX .....	28
Fig. 2-6	Installation dimensions for MICROMASTER 440 Frame size GX .....	29
Fig. 2-7	Options for the electronic box.....	32
Fig. 2-8	MICROMASTER 440 Connection Terminals.....	37
Fig. 2-9	MICROMASTER 440 connection drawing – frame size FX.....	38
Fig. 2-10	MICROMASTER 440 connection drawing - frame size GX.....	39
Fig. 2-11	Motor and Power Connections .....	40
Fig. 2-12	Adaptation of fan voltage.....	41
Fig. 2-13	Control terminals of MICROMASTER 440.....	42
Fig. 2-14	Wiring Guidelines to Minimize the Effects of EMI .....	44
Fig. 3-1	Parameter types .....	51
Fig. 3-2	Header line for parameter P0305 .....	55
Fig. 3-3	Parameter grouping / access.....	56
Fig. 3-4	Binectors .....	60
Fig. 3-5	Connectors .....	61
Fig. 3-6	BICO connections (examples).....	62
Fig. 3-7	Example: Changeover from motor 1 to motor 2.....	63
Fig. 3-8	Example: Changing-over between the control and setpoint (frequency) source.....	63
Fig. 3-9	Copying from CDS .....	65
Fig. 3-10	Changing-over CDS .....	65
Fig. 3-11	Copying from DDS .....	66
Fig. 3-12	Changing-over DDS .....	67
Fig. 3-13	Normalization / de-normalization .....	69
Fig. 3-14	Operator panels.....	70
Fig. 3-15	Operator panel keys .....	72
Fig. 3-16	Changing parameters using the BOP .....	73
Fig. 3-17	MICROMASTER 440 – block diagram .....	74
Fig. 3-18	Status Display Panel (SDP).....	75
Fig. 3-19	Recommended wiring for the factory setting .....	76
Fig. 3-20	Procedure when commissioning.....	77
Fig. 3-21	DIP switch to change-over between 50/60 Hz.....	79
Fig. 3-22	Mode of operation of the DIP50/60 switch in conjunction with P0100 .....	79
Fig. 3-23	Motor terminal box.....	80
Fig. 3-24	Star / delta circuit configurations .....	81
Fig. 3-25	V/f characteristic.....	82
Fig. 3-26	Equivalent circuit diagram (ECD) .....	91
Fig. 3-27	Magnetizing characteristic.....	92
Fig. 3-28	Upgrade / download using AOP and PC Tools.....	132
Fig. 3-29	Digital inputs.....	135
Fig. 3-30	Digital outputs.....	138
Fig. 3-31	DIP switch and P0756 for ADC current / voltage input .....	140

Fig. 3-32	Connection example for ADC voltage / current input.....	141
Fig. 3-33	ADC channel .....	141
Fig. 3-34	Signal output through the D/A converter channel .....	142
Fig. 3-35	D/A converter channel.....	142
Fig. 3-36	Serial communication interfaces - BOP link and COM link .....	144
Fig. 3-37	Cycle times.....	147
Fig. 3-38	Serial linking of MICROMASTER (slaves) with a higher-level computer (master) .....	148
Fig. 3-39	Telegram structure .....	149
Fig. 3-40	Assignment of the address byte (ADR) .....	150
Fig. 3-41	Circulating list (Example of configuration) .....	151
Fig. 3-42	Cycle time.....	151
Fig. 3-43	Transmit sequence .....	152
Fig. 3-44	USS bus topology.....	153
Fig. 3-45	Telegram structure .....	155
Fig. 3-46	Structure of the PKW and PZD areas.....	155
Fig. 3-47	Connecting the USS bus cable.....	164
Fig. 3-48	Connecting the RS485 terminator .....	165
Fig. 3-49	Example for directly selecting FF1 via DIN1 and FF2 via DIN2.....	168
Fig. 3-50	Example for selecting FF1 via DIN1 and FF2 via DIN2 using the binary-coded method ....	169
Fig. 3-51	Motorized potentiometer.....	170
Fig. 3-52	JOG counter-clockwise and JOG clockwise .....	172
Fig. 3-53	Structure of the technology controller.....	174
Fig. 3-54	Structure of the technological controller (PID controller) .....	175
Fig. 3-55	PID controller.....	176
Fig. 3-56	Example to directly select the PID fixed frequency of fixed frequency 1 via DIN1.....	178
Fig. 3-57	PID dancer roll control.....	179
Fig. 3-58	Structure of the closed-loop PID-dancer roll control .....	180
Fig. 3-59	Setpoint channel.....	181
Fig. 3-60	Summation .....	182
Fig. 3-61	Modifying the frequency setpoint.....	182
Fig. 3-62	Ramp-function generator.....	183
Fig. 3-63	Rounding off after an OFF1 command .....	184
Fig. 3-64	OFF1 .....	186
Fig. 3-65	OFF2 .....	187
Fig. 3-66	OFF3 .....	188
Fig. 3-67	Changing-over using the BICO parameters P0810 and P0811 .....	189
Fig. 3-68	Motor holding brake after ON / OFF1 .....	196
Fig. 3-69	Motor holding brake after OFF2 .....	197
Fig. 3-70	Direct motor holding brake connection .....	200
Fig. 3-71	Indirect motor holding brake connection.....	201
Fig. 3-72	Inter-dependency of the electronic brakes.....	202
Fig. 3-73	DC braking after OFF1 / OFF3.....	203
Fig. 3-74	DC braking after external selection .....	204
Fig. 3-75	Compound braking .....	205
Fig. 3-76	Connecting the chopper (braking) resistor.....	207
Fig. 3-77	Mode of operation of the dynamic braking.....	207

Fig. 3-78	Load duty cycle – chopper resistors (MICROMASTER Catalog DA51.2).....	208
Fig. 3-79	Increasing the level of braking energy which can be absorbed .....	209
Fig. 3-80	Chopper load duty cycle .....	209
Fig. 3-81	Automatic restarts .....	211
Fig. 3-82	Flying restart.....	214
Fig. 3-83	Vdc_max controller.....	216
Fig. 3-84	Kinetic buffering (Vdc_min controller).....	218
Fig. 3-85	Positioning down ramp .....	219
Fig. 3-86	Rotary or linear axis.....	220
Fig. 3-87	Shaft drive with flat belts.....	223
Fig. 3-88	Load torque monitoring (P2181 = 1).....	223
Fig. 3-89	Frequency/torque tolerance bandwidth .....	224
Fig. 3-90	Load torque characteristic with minimum permissible load.....	225
Fig. 3-91	Load torque characteristic with maximum permissible load.....	225
Fig. 3-92	Load torque characteristic with minimum and maximum permissible load .....	226
Fig. 3-93	Thermal motor protection .....	228
Fig. 3-94	Connecting a temperature sensor to MICROMASTER.....	230
Fig. 3-95	PTC characteristic for 1LG / 1LA motors .....	231
Fig. 3-96	KTY84 characteristic for 1LG / 1LA motors .....	231
Fig. 3-97	Operating ranges and characteristics of an induction motor when fed from a drive inverter.....	236
Fig. 3-98	Slip compensation .....	239
Fig. 3-99	Effect of V/f resonance damping .....	240
Fig. 3-100	I <sub>max</sub> controller.....	242
Fig. 3-101	Current Vector diagram in a steady-state condition.....	243
Fig. 3-102	Changeover condition for SLVC.....	245
Fig. 3-103	Starting and passing-through 0 Hz in closed-loop controlled operation.....	246
Fig. 3-104	P0400 and DIP switch on the pulse encoder module .....	247
Fig. 3-105	Speed controller .....	248
Fig. 3-106	Speed controller with pre-control.....	250
Fig. 3-107	Speed controller with droop.....	252
Fig. 3-108	Closed-loop speed/torque control.....	253
Fig. 3-109	Torque limits.....	255

### List of Tables

Table 2-1	Dimensions and Torques of MICROMASTER 440.....	30
Table 3-1	Parameter attributes.....	52
Table 3-2	Parameter P0700 .....	57
Table 3-3	Parameter P1000 .....	58
Table 3-4	Parameter P0719 .....	59
Table 3-5	Normalized interfaces.....	68
Table 3-6	Normalization functions .....	68
Table 3-7	Pre-assignment of the digital inputs .....	75
Table 3-8	Example 1LA7060-4AB10 .....	82
Table 3-9	Possible settings for parameter P0340.....	88
Table 3-10	Calculated parameters .....	89
Table 3-11	Parameters P0701 – P0706 .....	136

Table 3-12	Parameters P0731 – P0733 (frequently used functions / states).....	138
Table 3-13	BOP link .....	145
Table 3-14	COM link.....	145
Table 3-15	Minimum start intervals for various baud rates .....	152
Table 3-16	Structural data .....	153
Table 3-17	Thermal and electrical characteristics .....	154
Table 3-18	Max. number of nodes (devices) depending on the max. data transfer rate.....	154
Table 3-19	Task IDs (master -> drive converter) .....	158
Table 3-20	Response ID (converter -> master) .....	159
Table 3-21	Fault numbers for the response ID "Request cannot be executed" .....	160
Table 3-22	Example for direct coding via digital inputs.....	167
Table 3-23	Example for binary coding via digital inputs.....	168
Table 3-24	Mode of operation of the MOP .....	171
Table 3-25	Selecting the motorized potentiometer .....	171
Table 3-26	Correspondence between the parameters .....	177
Table 3-27	Important parameters for the PID dancer roll control.....	180
Table 3-28	BICO parameters for ramp-function generator .....	185
Table 3-29	Examples for settings of parameter P0810.....	190
Table 3-30	Possible settings for parameters P0700 and P1000.....	190
Table 3-31	Free function blocks .....	191
Table 3-32	FFB priority table .....	194
Table 3-33	Settings for parameter P1200.....	213
Table 3-34	DC link undervoltage – shutdown threshold .....	219
Table 3-35	Partial excerpt of monitoring functions / messages .....	222
Table 3-36	Thermal classes .....	228
Table 3-37	General protection of the power components.....	232
Table 3-38	V/f characteristic (parameter P1300) .....	236
Table 3-39	Voltage boost .....	238
Table 3-40	Vector control versions .....	244
Table 4-1	Inverter conditions indicated by the LEDs on the SDP .....	258
Table 5-1	MICROMASTER 440 Performance Ratings .....	262
Table 5-2	Dimensions, required cooling air flow and tightening torques for power terminals .....	264
Table 5-3	Current reduction depending on pulse frequency .....	265
Table 5-4	Data for braking resistors .....	266
Table 5-5	MICROMASTER 440 Specifications .....	266
Table 7-1	Permissible harmonic current emissions .....	277
Table 7-2	General industrial application .....	278
Table 7-3	With filter, for industrial applications .....	278
Table 7-4	With filter, for residential, commercial and trade applications.....	279
Table 7-5	Compliance Table .....	280

# 1 Overview

**This Chapter contains:**

A summary of the major features of the MICROMASTER 440 range.

1.1	The MICROMASTER 440.....	18
1.2	Features.....	19

www.ElectricalPartManuals.com

## 1.1 The MICROMASTER 440

The MICROMASTER 440 are frequency inverters for speed and torque control of three-phase motors. The various models available cover the performance range from 120 W to 200 kW (for constant torque (CT), alternatively up to 250kW (for variable torque (VT)).

The inverters are microprocessor-controlled and use state-of-the-art Insulated Gate Bipolar Transistor (IGBT) technology. This makes them reliable and versatile. A special pulse-width modulation method with selectable Pulse frequency permits quiet motor operation. Comprehensive protective functions provide excellent inverter and motor protection.

With the factory default settings, the MICROMASTER 440 is suitable for many variable speed applications. Using the functionally grouped parameters, the MICROMASTER 440 can be adapted to more demanding applications.

The MICROMASTER 440 can be used in both 'stand-alone' applications as well as being integrated into 'Automation Systems'.

## 1.2 Features

### Main Characteristics

- Easy installation
- Easy commissioning
- Rugged EMC design
- Can be operated on IT line supplies
- Fast repeatable response time to control signals
- Comprehensive range of parameters enabling configuration for a wide range of applications
- Simple cable connection
- Output relays
- Analog outputs (0 – 20 mA)
- 6 Isolated and switchable NPN/PNP digital inputs
- 2 Analog inputs:
  - ◆ ADC1: 0 – 10 V, 0 – 20 mA and -10 to +10 V
  - ◆ ADC2: 0 – 10 V, 0 – 20 mA
- The 2 analog inputs can be used as the 7<sup>th</sup> and 8<sup>th</sup> digital inputs
- BICO technology
- Modular design for extremely flexible configuration
- High switching frequencies (drive inverter specific up to 16 kHz) for low-noise motor operation
- Internal RS485 interface (port)
- Detailed status information and integrated message functions

### Performance Characteristics

- Vector Control
  - ◆ Sensorless Vector Control (SLVC)
  - ◆ Vector Control with encoder (VC)
- V/f Control
  - ◆ Flux Current Control (FCC) for improved dynamic response and motor control
  - ◆ Multi-point V/f characteristic
- Automatic restart
- Flying restart
- Slip compensation
- Fast Current Limitation (FCL) for trip-free operation
- Motor holding brake
- Built-in DC injection brake
- Compound braking to improve braking performance
- Built-in braking chopper (Frame Sizes A to F) for resistor braking (dynamic braking)
- Setpoint input via:
  - ◆ Analog inputs
  - ◆ Communication interface
  - ◆ JOG function
  - ◆ Motorized potentiometer
  - ◆ Fixed frequencies
- Ramp function generator
  - ◆ With smoothing
  - ◆ Without smoothing
- Technology controller (PID)
- Parameter set switch-over
  - ◆ Motor data sets (DDS)
  - ◆ Command data sets and setpoint sources (CDS)
- Free Function Blocks
- DC link voltage controller
- Kinetic Buffering
- Positioning Ramp down

### Protection characteristics

- Overvoltage/undervoltage protection
- Overtemperature protection for the inverter
- Ground fault protection
- Short-circuit protection
- $i^2t$  thermal motor protection
- PTC/KTY84 for motor protection

### Options

- Refer to Chapter 5

## 2 Installation

**This Chapter contains:**

- General data relating to installation
- Dimensions of Inverter
- Wiring guidelines to minimize the effects of EMI
- Details concerning electrical installation

2.1	Installation after a Period of Storage .....	23
2.2	Ambient operating conditions .....	24
2.3	Mechanical installation.....	26
2.4	Electrical installation .....	33

www.ElectricalPartManuals.com



---

**WARNING**

- Work on the device/system by **unqualified** personnel or failure to comply with warnings can result in severe personal injury or serious damage to material. Only suitably qualified personnel trained in the setup, installation, commissioning and operation of the product should carry out work on the device/system.
  - Only permanently-wired input power connections are allowed. This equipment must be grounded (IEC 536 Class 1, NEC and other applicable standards).
  - Only type B ELCBs should be used with FSA to FSF. Machines with a three-phase power supply, fitted with EMC filters, must not be connected to a supply via an ELCB (Earth Leakage Circuit-Breaker - see *DIN VDE 0160, section 5.5.2 and EN50178 section 5.2.11.1*).
  - The following terminals can carry dangerous voltages even if the inverter is inoperative:
    - ◆ the power supply L/L1, N/L2, L3 resp. U1/L1, V1/L2, W1/L3
    - ◆ the motor terminals U, V, W resp. U2, V2, W2
    - ◆ and depending on the frame size the terminals DC+/B+, DC-, B-, DC/R+ resp. DCPS, DCNS, DCPA, DCNA
  - Always wait **5 minutes** to allow the unit to discharge after switching off before carrying out any installation work.
  - This equipment must not be used as an 'emergency stop mechanism' (see *EN 60204, 9.2.5.4*)
  - The minimum size of the earth-bonding conductor must be equal to or greater than the cross-section of the power supply cables.
  - If the front cover (Frame Sizes FX and GX) has been removed, the fan impeller is exposed. There is danger of injury when the fan is running.
- 

**CAUTION**

The connection of power, motor and control cables to the inverter must be carried out as shown in Fig. 2-11 on page 44, to prevent inductive and capacitive interference from affecting the correct functioning of the inverter.

---

## 2.1 Installation after a Period of Storage

Following a prolonged period of storage, you must reform the capacitors in the inverter.

### Frame Sizes A to F

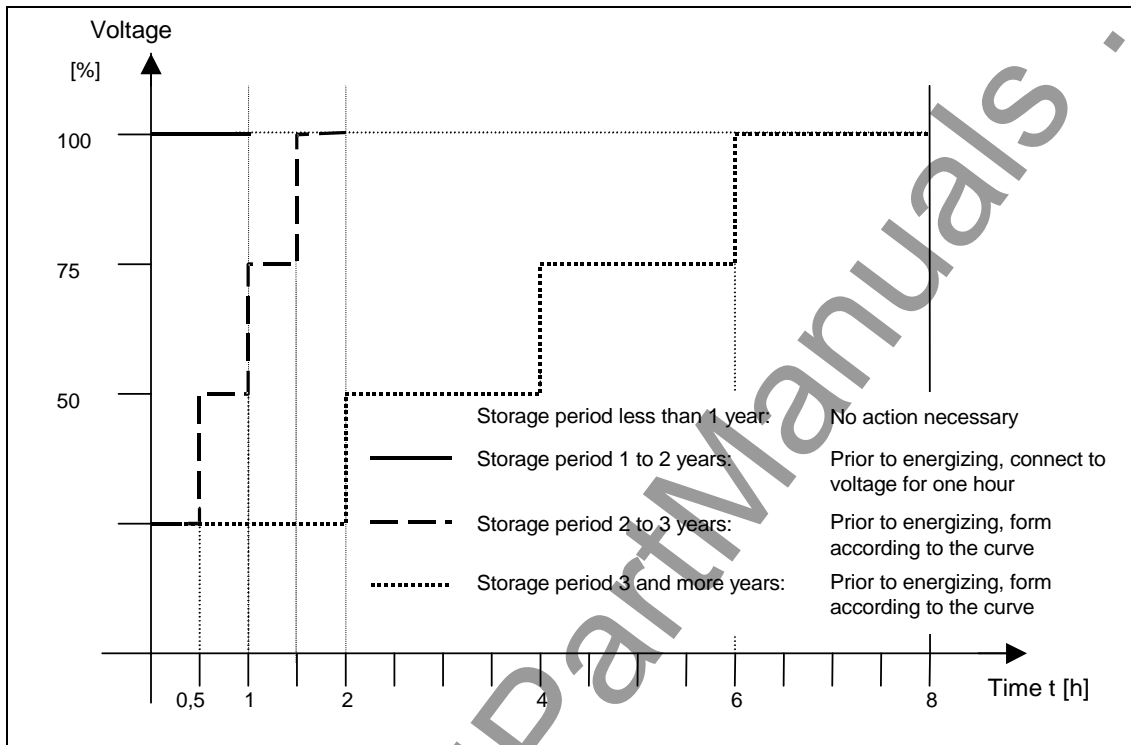


Fig. 2-1 Forming

### Frame Sizes FX and GX

Reforming the capacitors can be accomplished by applying 85% of the rated input voltage for at least 30 minutes without load.

## 2.2 Ambient operating conditions

### Temperature

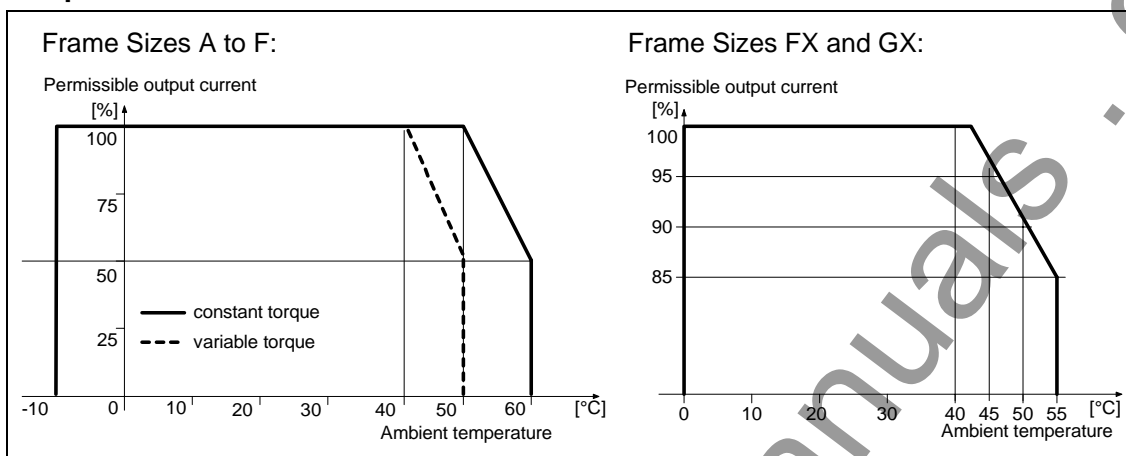


Fig. 2-2 Ambient operating temperature

### Humidity Range

Relative air humidity ≤ 95 % Non-condensing

### Altitude

If the inverter is to be installed at an altitude > 1000 m or > 2000 m above sea level, derating will be required:

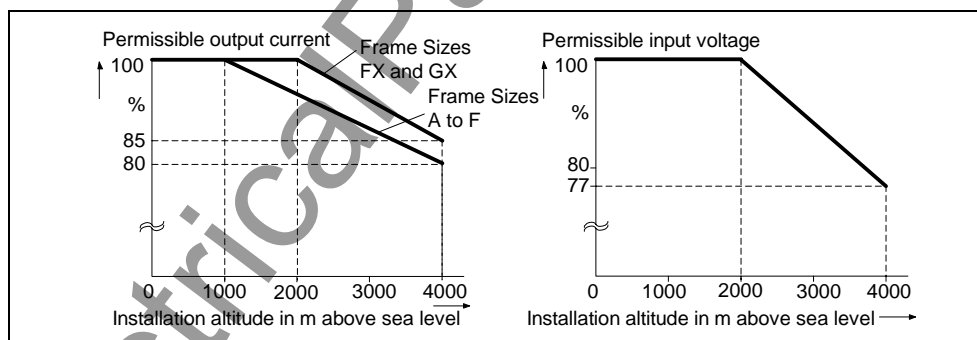


Fig. 2-3 Installation altitude

### Shock and Vibration

Do not drop the inverter or expose to sudden shock. Do not install the inverter in an area where it is likely to be exposed to constant vibration.

Mechanical strength to EN 60721-33

- Deflection: 0.075 mm (10 ... 58 Hz)
- Acceleration: 9.8 m/s<sup>2</sup> (> 58 ... 200 Hz)

### Electromagnetic Radiation

Do not install the inverter near sources of electromagnetic radiation.

### Atmospheric Pollution

Do not install the inverter in an environment, which contains atmospheric pollutants such as dust, corrosive gases, etc.

### Water

Take care to site the inverter away from potential water hazards, e.g. do not install the inverter beneath pipes that are subject to condensation. Avoid installing the inverter where excessive humidity and condensation may occur.

### Installation and cooling

---

#### CAUTION

The inverters **MUST NOT** be mounted horizontally.

---

The inverters can be mounted without any clearance at either side. When mounting inverters one above the other, the specified environmental conditions must not be exceeded.

Independent of this, these minimum distances must be observed.

- Frame Size A, B, C above and below 100 mm
- Frame Size D, E above and below 300 mm
- Frame Size F above and below 350 mm
- Frame Size FX, GX above 250 mm  
below 150 mm  
in front 40 mm (FX), 50 mm (GX)

No equipment that could have a negative effect on the flow of cooling air should be installed in this area. Make sure that the cooling vents in the inverter are positioned correctly to allow free movement of air.

## 2.3 Mechanical installation



### WARNING

- To ensure the safe operation of the equipment, it must be installed and commissioned by qualified personnel in full compliance with the warnings laid down in these operating instructions.
- Take particular note of the general and regional installation and safety regulations regarding work on dangerous voltage installations (e.g. EN 50178), as well as the relevant regulations regarding the correct use of tools and personal protective equipment (PPE).
- The mains input, DC and motor terminals, can carry dangerous voltages even if the inverter is inoperative; wait **5 minutes** to allow the unit to discharge after switching off before carrying out any installation work.
- The inverters can be mounted without any clearance at either side. When mounting inverters one above the other, the specified environmental conditions must not be exceeded. Independent of this, these minimum distances must be observed.
  - Frame Size A, B, C above and below 100 mm
  - Frame Size D, E above and below 300 mm
  - Frame Size F above and below 350 mm
  - Frame Size FX, GX above 250 mm  
below 150 mm  
in front 40 mm (FX), 50 mm (GX)
- If the front cover (Frame Sizes FX and GX) has been removed, the fan impeller is exposed. There is danger of injury when the fan is running.
- IP20 protection is only against direct contact, always use these products within a protective cabinet.

### Removing from transport pallet (only for frame sizes FX and GX)

During transport, the inverter is fastened on the transport pallet with the aid of two iron brackets.



### WARNING

Note that the center of gravity of the inverter is not in the middle of the unit. When lifting the pallet, the unit can therefore suddenly change position and swing to the side.

1. Fasten the hoisting crane cable to the hoisting eyes on the inverter (2 eyes, see Fig. 2-9 and Fig. 2-10).
2. Remove the two retaining bolts at the top of the front cover.
3. Unscrew the bolts in the iron brackets on the transport pallet and lift the inverter off the pallet.
4. Once installation has been completed and the inverter connected, fasten the two retaining bolts for the front cover at the bottom side of the door.

Frame Sizes A to F

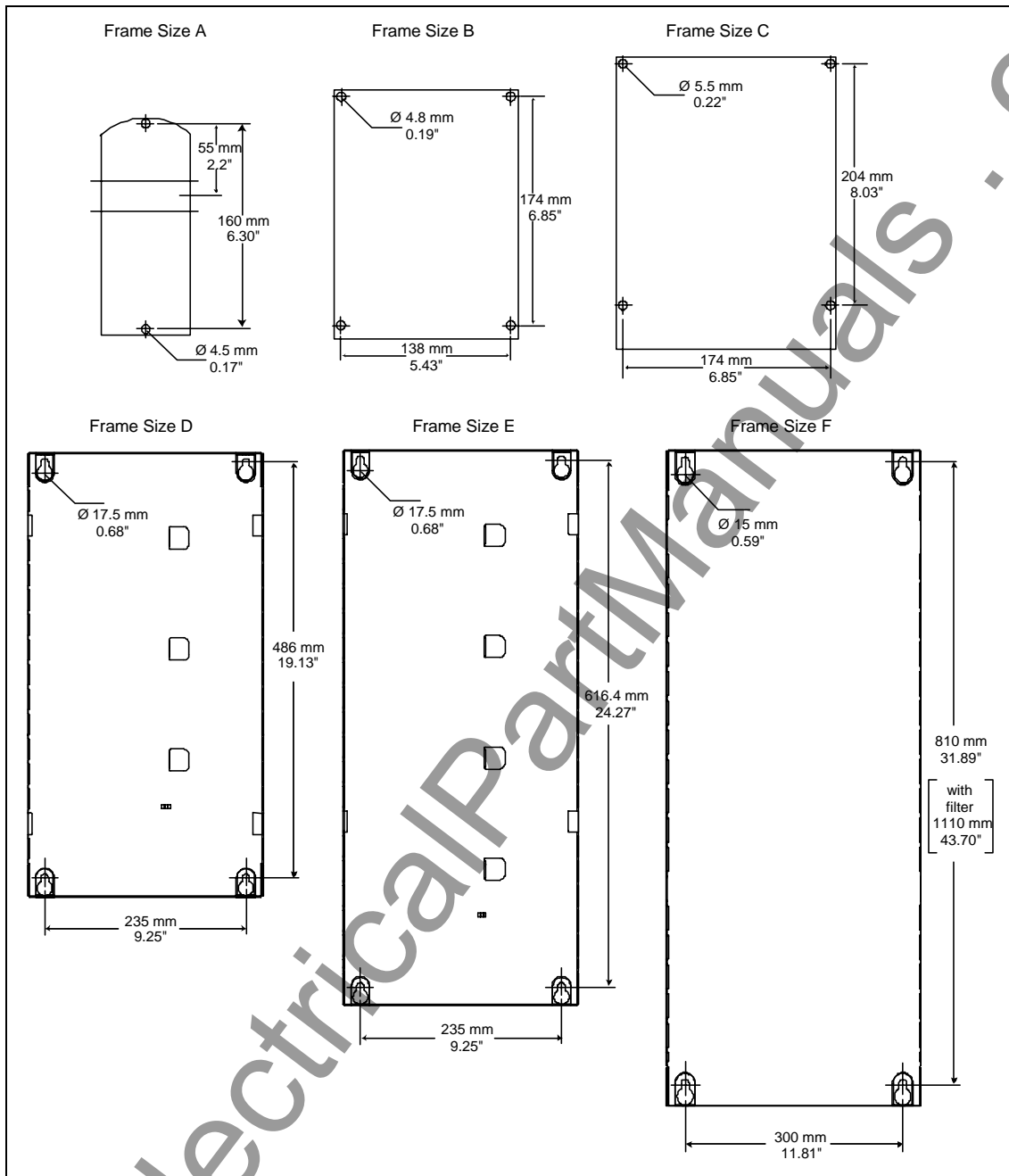


Fig. 2-4 Drill pattern for MICROMASTER 440

Frame Size FX

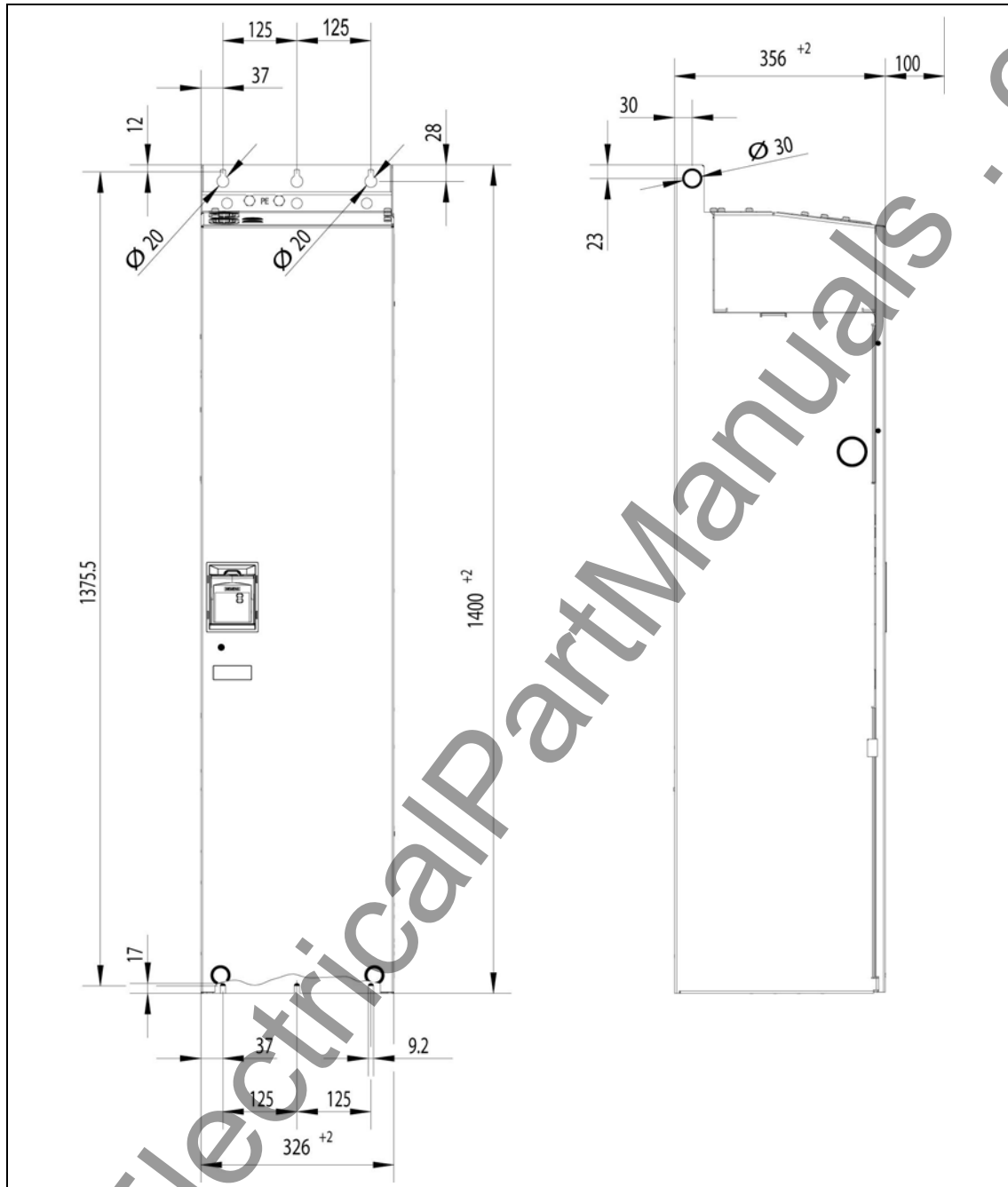


Fig. 2-5 Installation dimensions for MICROMASTER 440 Frame size FX

Frame Size GX

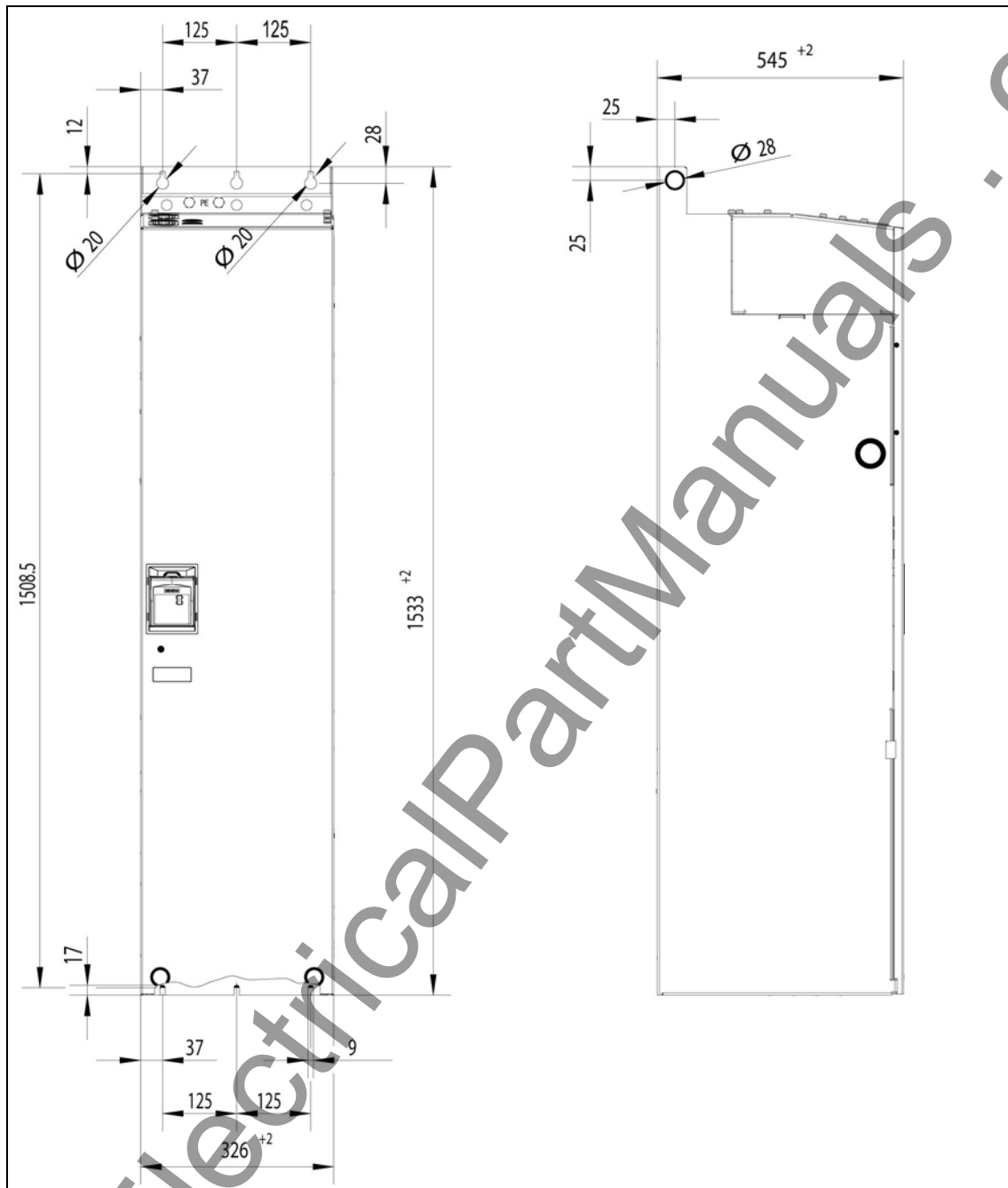


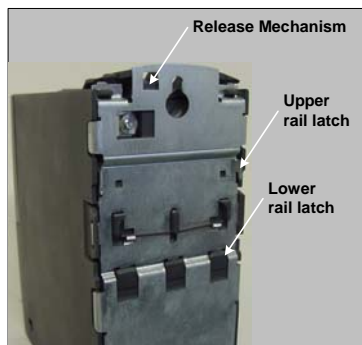
Fig. 2-6 Installation dimensions for MICROMASTER 440 Frame size GX

Table 2-1 Dimensions and Torques of MICROMASTER 440

Frame-Size		Overall Dimensions		Fixing Method	Tightening Torque
A	Width x Height x Depth	mm	73 x 173 x 149	2 M4 Bolts 4 M4 Nuts 4 M4 Washers or fitting on a standard rail	2,5 Nm with washers fitted
		inch	2,87 x 6,81 x 5,87		
B	Width x Height x Depth	mm	149 x 202 x 172	4 M4 Bolts 4 M4 Nuts 4 M4 Washers	2,5 Nm with washers fitted
		inch	5,87 x 7,95 x 6,77		
C	Width x Height x Depth	mm	185 x 245 x 195	4 M5 Bolts 4 M5 Nuts 4 M5 Washers	2,5 Nm with washers fitted
		inch	7,28 x 9,65 x 7,68		
D	Width x Height x Depth	mm	275 x 520 x 245	4 M8 Bolts 4 M8 Nuts 4 M8 Washers	3,0 Nm with washers fitted
		inch	10,82 x 20,47 x 9,65		
E	Width x Height x Depth	mm	275 x 650 x 245	4 M8 Bolts 4 M8 Nuts 4 M8 Washers	3,0 Nm with washers fitted
		inch	10,82 x 25,59 x 9,65		
F	Width x Height x Depth	mm	350 x 850 mm x 320 height with filter 1150	4 M8 Bolts 4 M8 Nuts 4 M8 Washers	3,0 Nm with washers fitted
		inch	13,78 x 33,46 x 12,60 height with filter 45,28		
FX	Width x Height x Depth	mm	326 x 1400 x 356	6 M8 Bolts 6 M8 Nuts 6 M8 Washers	13 Nm +30 % with washers fitted
		inch	12,80 x 55,12 x 12,83		
GX	Width x Height x Depth	mm	326 x 1533 x 545	6 M8 Bolts 6 M8 Nuts 6 M8 Washers	13 Nm +30 % with washers fitted
		inch	12,80 x 60,35 x 21,46		

### 2.3.1 Mounting onto standard rail, Frame Size A

#### Mounting the inverter onto a 35 mm standard rail (EN 50022)



1. Locate the inverter on the mounting rail using the upper rail latch
2. Using a flat blade screwdriver, press the release mechanism downwards and engage the inverter into the lower rail latch.



#### Removing the Inverter from the rail

1. To disengage the release mechanism of the inverter, insert a screwdriver into the release mechanism.
2. Apply a downward pressure and the lower rail latch will disengage.
3. Pull the inverter from the rail.

### 2.3.2 Installing communication options and/or pulse encoder evaluation module

#### Sizes A to F

##### NOTE

When installing the following options – PROFIBUS module, DeviceNet module, CANOpen option module and/or pulses encoder evaluation module, the mounting depth of the drive inverter is increased!

Please refer to the relevant Operating Instructions for the actual procedure.

#### Sizes FX and GX

The front cover of the MICROMASTER 440 is designed so that the control module (normally the SDP) is almost flush with the opening in the front cover. If more than one option is to be installed in the electronic box, it is necessary to position the entire electronic box further to the rear

##### Installing the options

- Remove the front cover:
  - Unscrew two screws at the bottom side of the front cover.
  - Lift front cover up and out.
- Remove retaining screws on the electronic box.
- Screw on electronic box in correct installation position as shown in Fig. 2-7
- Install additional options.
- Reinstall front cover.

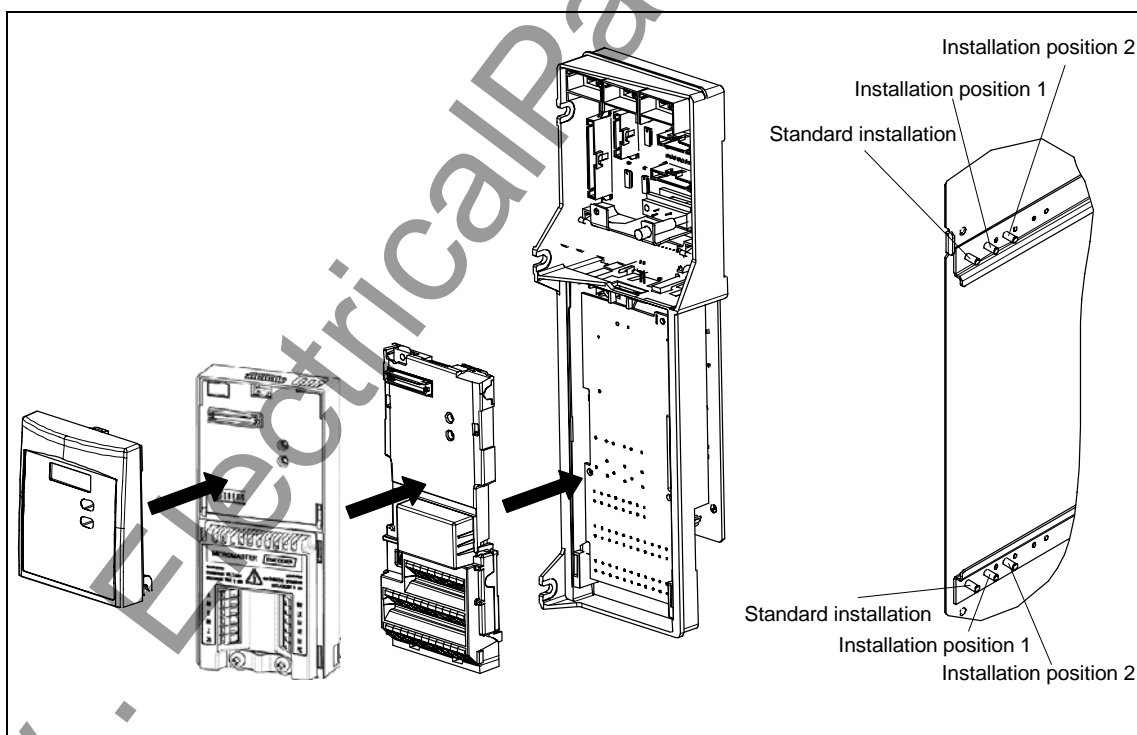


Fig. 2-7 Options for the electronic box

## 2.4 Electrical installation

---



### WARNING

**The inverter must always be grounded.**

- To ensure the safe operation of the equipment, it must be installed and commissioned by qualified personnel in full compliance with the warnings laid down in these operating instructions.
  - Take particular note of the general and regional installation and safety regulations regarding work on dangerous voltage installations (e.g. EN 50178), as well as the relevant regulations regarding the correct use of tools and personal protective gear.
  - Never use high voltage insulation test equipment on cables connected to the inverter.
  - The mains input, DC and motor terminals, can carry dangerous voltages even if the inverter is inoperative; wait **5 minutes** to allow the unit to discharge after switching off before carrying out any installation work.
  - If the front cover (Frame Sizes FX and GX) has been removed, the fan impeller is exposed. There is danger of injury when the fan is running.
- 
- 

### CAUTION

The control, power supply and motor leads **must** be laid separately. Do not feed them through the same cable conduit/trunking.

---

### 2.4.1 General



#### WARNING

**The inverter must always be grounded.** If the inverter is not grounded correctly, extremely dangerous conditions may arise within the inverter which could prove potentially fatal.

#### Operation with ungrounded (IT) supplies

##### Filtered

The use of filtered MICROMASTER 4 drives on unearthed mains supplies is not permitted.

##### Unfiltered

In the case of non-grounded networks, the 'Y' capacitor of the device must be made ineffective. The procedure is described in Appendix D.

If the MICROMASTER is to remain in operation in non-grounded networks when a ground fault occurs during the input or output phase, an output reactor must be installed.

#### Operation with Residual Current Device (Frame Sizes A to F)

If an RCD (also referred to as ELCB or RCCB) is fitted, the MICROMASTER inverters will operate without nuisance tripping, provided that:

- A type B RCD is used.
- The trip limit of the RCD is 300 mA.
- The neutral of the supply is grounded.
- Only one inverter is supplied from each RCD.
- The output cables are less than 50 m (screened) or 100 m (unscreened).

#### NOTE

The residual current operated circuit-breakers used must provide protection against direct-current components in the fault current and must be suitable for briefly suppressing power pulse current peaks. It is recommended to protect the frequency inverter by fuse separately.

**The regulations of the individual country (e.g. VDE regulations in Germany) and the regional power suppliers must be observed!**

## 2.4.2 Power and motor connections



### WARNING

**The inverter must always be grounded.**

- ◆ Isolate the mains electrical supply before making or changing connections to the unit.
- ◆ Ensure that the inverter is configured for the correct supply voltage: MICROMASTERS must not be connected to a higher voltage supply.
- ◆ When synchronous motors are connected or when coupling several motors in parallel, the inverter must be operated with V/f control characteristic (P1300 = 0, 2 or 3).



### CAUTION

After connecting the power and motor cables to the proper terminals, make sure that the front covers have been replaced properly before supplying power to the unit!

### NOTICE

- ◆ Ensure that the appropriate circuit-breakers/fuses with the specified current rating are connected between the power supply and inverter (see chapter 5, Tables 5-5).
- ◆ Use Class 1 60/75 °C copper wire only (for UL compliance). For tightening torque see Table 5-2.

## Operation with long cables

All inverters will operate at full specification with cable lengths as follows:

Frame Sizes	A to F	FX and GX
screened	50 m	100 m
unscreened	100 m	150 m

Using the output chokes specified in catalogue DA 51.2, the following cable lengths are possible for the appropriate frame sizes:

Supply Voltage	200 V ... 240 V ± 10%		380 V ... 400 V ± 10 %			401 V ... 480 V ± 10 %			500 V ... 600 V ± 10%	
	A ... F	A ... B	C	D ... F	FX, GX	A ... C	D ... F	FX, GX	C	D ... F
screened	200 m	150 m	200 m	200 m	300 m	100 m	200 m	300 m	100 m	200 m
unscreened	300 m	225 m	300 m	300 m	450 m	150 m	300 m	450 m	150 m	300 m

### CAUTION

If using output chokes operation is only permissible with a pulse frequency of **4 kHz**. Make shure that the automatic pulse frequency reductions are disabled.  
**Coercing required parameter adjusting: P1800 = 4 kHz , P0290 = 0 or 1.**

**Access to the power and motor terminals**

Access to the power supply and motor terminals is possible by removing the front covers (See Fig. 2-8 to Fig. 2-10). See also Appendix B.

After removing the front covers and exposing the terminals, complete power and motor connections as shown in Fig. 2-11.

**Connection of braking unit (only for framesize FX and GX)**

A passage opening for access to the intermediate circuit connections has been provided on the top side of the inverter. It is possible to connect an external braking unit (refer to Catalog DA65.11 or DA65.10) to these terminals. The position is shown in Fig. 2-9 and Fig. 2-10.

The maximum cross section of connections is 50 mm<sup>2</sup>, but only provided the crimped area of cable shoes on the equipment side is provided with a heat-shrinkable sleeve. This measure is important to ensure that air gaps and creep distances are observed.

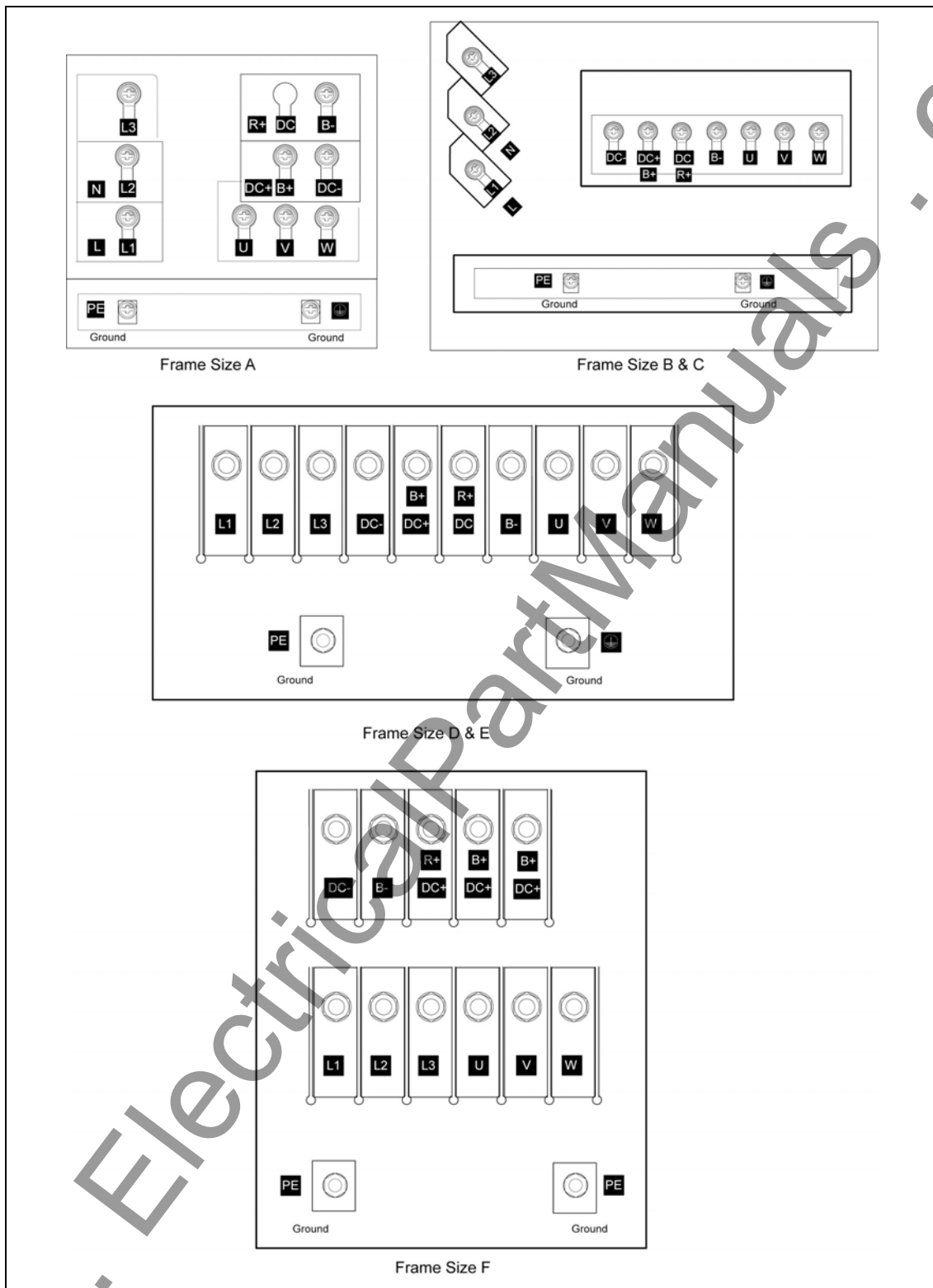


Fig. 2-8 MICROMASTER 440 Connection Terminals

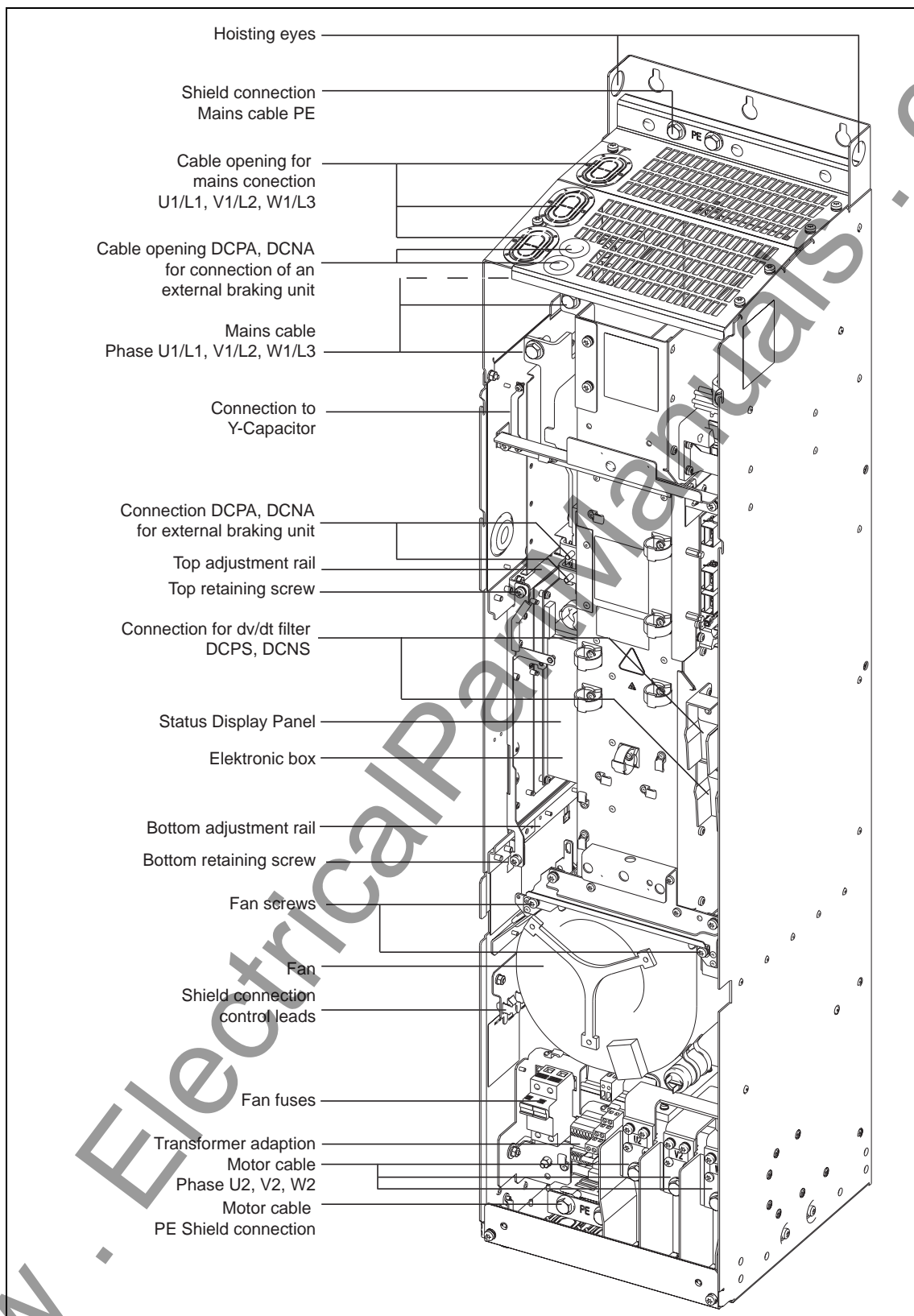


Fig. 2-9 MICROMASTER 440 connection drawing – frame size FX

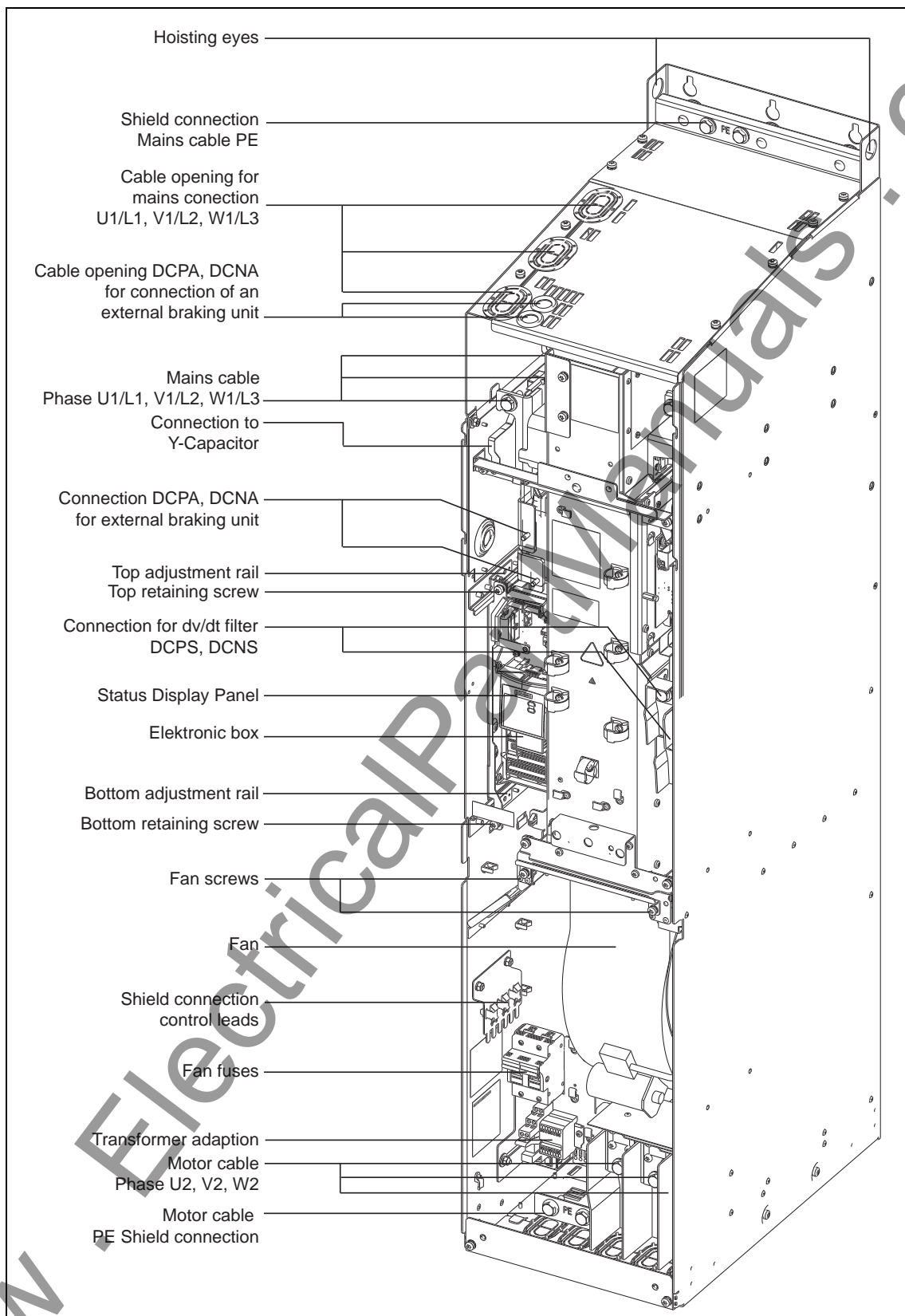
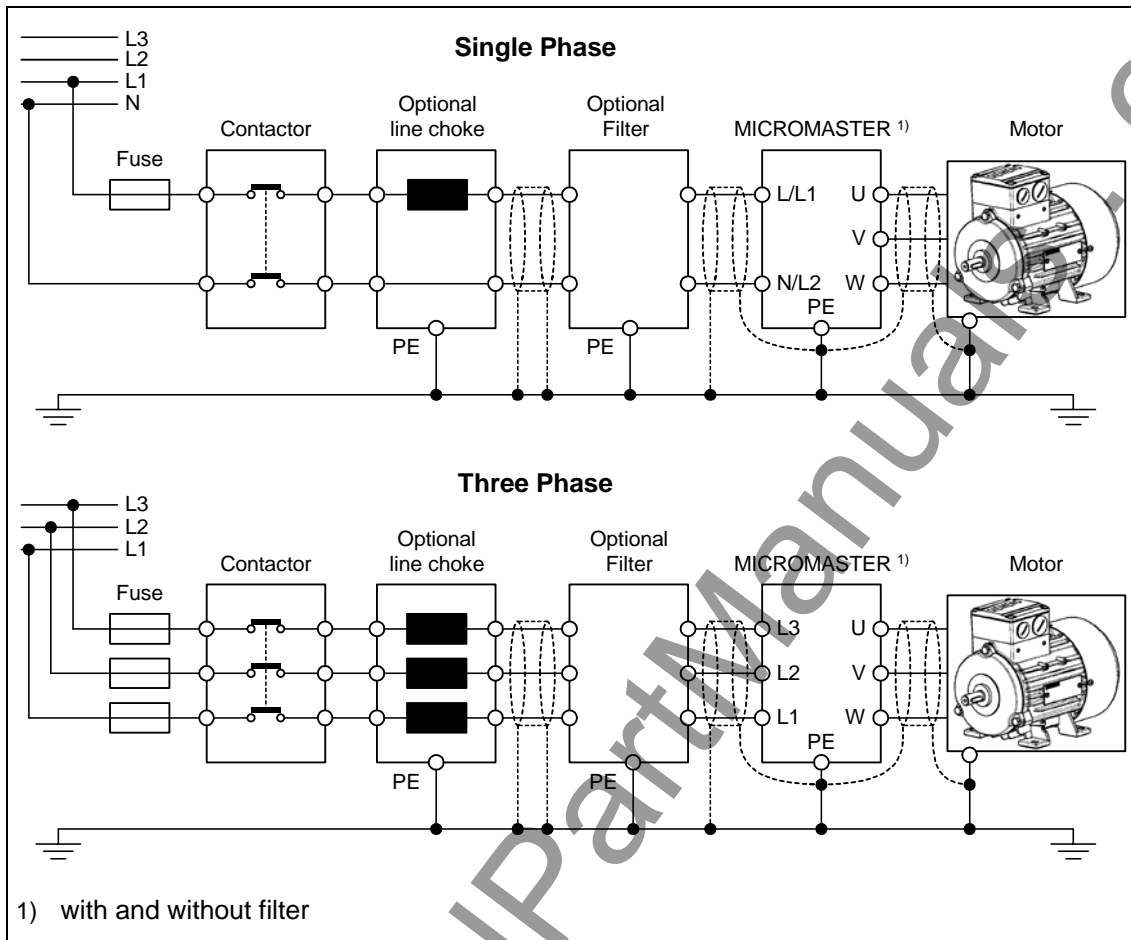


Fig. 2-10 MICROMASTER 440 connection drawing - frame size GX

Frame Sizes A to F



Frame Sizes FX and GX

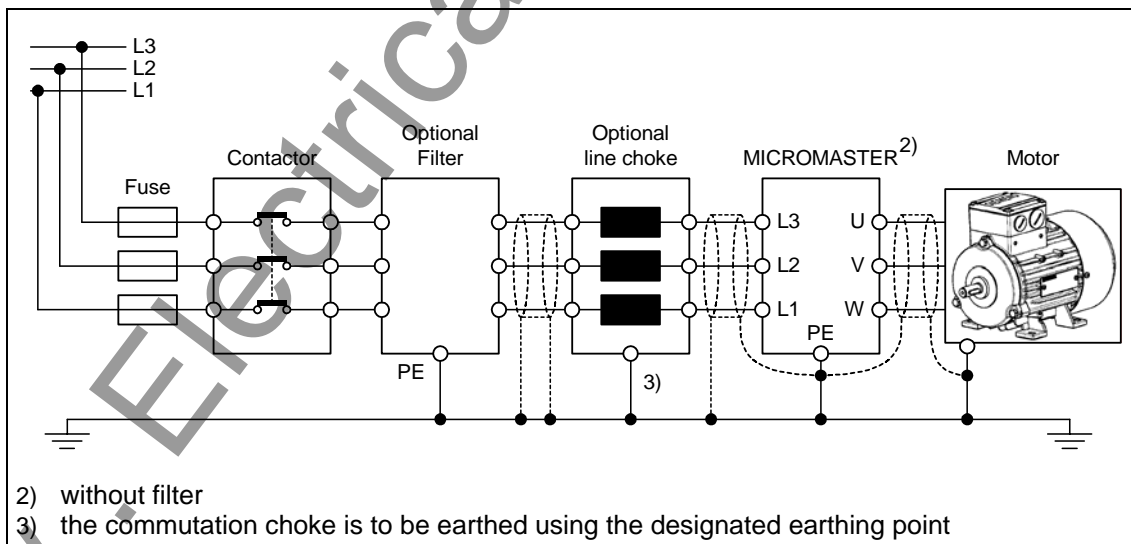


Fig. 2-11 Motor and Power Connections

**Adaptation of fan voltage (only for frame size FX and GX)**

A transformer is installed to adapt the existing line voltage to the fan voltage.

It may be necessary to reconnect the transformer terminals on the primary side to coincide with the existing line power.

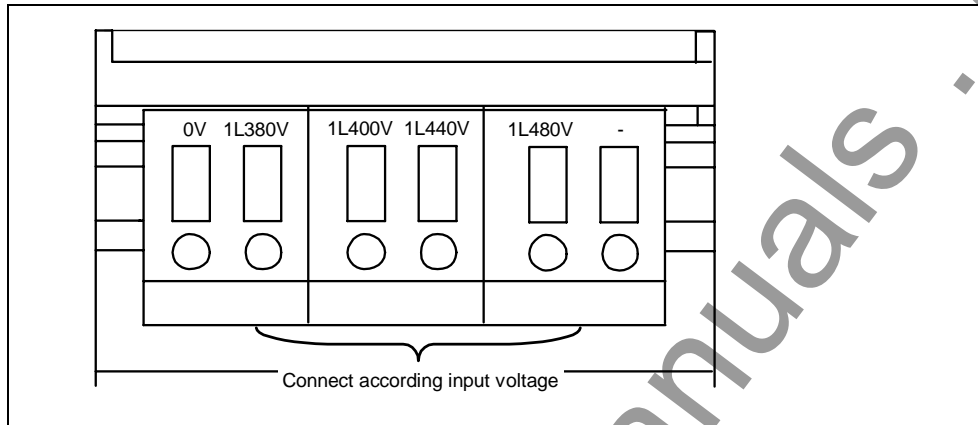


Fig. 2-12 Adaptation of fan voltage

**CAUTION**

If the terminals are not reconnected to the actually present line voltage, the fan fuses can blow.

**Replacement for fan fuses**

Frame size	Fuses (2 each)	Recommended fuses
FX (90 kW CT)	1 A / 600 V / slow-acting	Cooper-Bussmann FNQ-R-1, 600 V or comparable fuse
FX (110 kW CT)	2,5 A / 600 V / slow-acting	Ferraz Gould Shawmut ATDR2-1/2, 600 V or comparable fuse
GX (132-200 kW CT)	4 A / 600 V / slow-acting	Ferraz Gould Shawmut ATDR4, 600 V or comparable fuse

### 2.4.3 Control terminals

Permitted cable diameters: 0.08 ... 2.5 mm<sup>2</sup> (AWG: 28 ... 12)

Terminal	Designation	Function
1	–	Output +10 V
2	–	Output 0 V
3	ADC1+	Analog input 1 (+)
4	ADC1-	Analog input 1 (-)
5	DIN1	Digital input 1
6	DIN2	Digital input 2
7	DIN3	Digital input 3
8	DIN4	Digital input 4
9	–	Isolated output +24 V / max. 100 mA
10	ADC2+	Analog input 2 (+)
11	ADC2-	Analog input 2 (-)
12	DAC1+	Analog output 1 (+)
13	DAC1-	Analog output 1 (-)
14	PTCA	Connection for PTC / KTY84
15	PTCB	Connection for PTC / KTY84
16	DIN5	Digital input 5
17	DIN6	Digital input 6
18	DOUT1/NC	Digital output 1 / NC contact
19	DOUT1/NO	Digital output 1 / NO contact
20	DOUT1/COM	Digital output 1 / Changeover contact
21	DOUT2/NO	Digital output 2 / NO contact
22	DOUT2/COM	Digital output 2 / Changeover contact
23	DOUT3/NC	Digital output 3 / NC contact
24	DOUT3/NO	Digital output 3 / NO contact
25	DOUT3/COM	Digital output 3 / Changeover contact
26	DAC2+	Analog output 2 (+)
27	DAC2-	Analog output 2 (-)
28	–	Isolated output 0 V / max. 100 mA
29	P+	RS485 port
30	N-	RS485 port

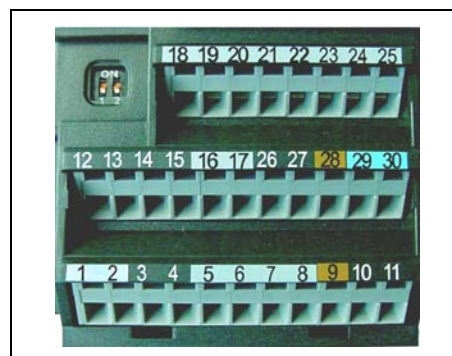


Fig. 2-13 Control terminals of MICROMASTER 440

A detailed description of the inputs and outputs is provided in Section 3.6.

#### 2.4.4 Avoiding Electro-Magnetic Interference (EMI)

The inverters are designed to operate in an industrial environment where a high level of EMI can be expected. Usually, good installation practices will ensure safe and trouble-free operation. If you encounter problems, follow the guidelines stated below.

##### Action to Take

- Ensure that all equipment in the cubicle is well grounded using short, thick grounding cable connected to a common star point or busbar
- Make sure that any control equipment (such as a PLC) connected to the inverter is connected to the same ground or star point as the inverter via a short thick link.
- Connect the return ground from the motors controlled by the inverters directly to the ground connection (PE) on the associated inverter
- Flat conductors are preferred as they have lower impedance at higher frequencies
- Terminate the ends of the cable neatly, ensuring that unscreened wires are as short as possible
- Separate the control cables from the power cables as much as possible, using separate trunking, if necessary at 90° to each other.
- Whenever possible, use screened leads for the connections to the control circuitry
- Ensure that the contactors in the cubicle are suppressed, either with R-C suppressors for AC contactors or 'flywheel' diodes for DC contactors fitted to the coils. Varistor suppressors are also effective. This is important when the contactors are controlled from the inverter relay
- Use screened or armored cables for the motor connections and ground the screen at both ends using the cable clamps



---

##### WARNING

Safety regulations **must not** be compromised when installing inverters!

---

## 2.4.5 Screening Methods

### Frame Sizes A, B and C

For frame sizes A, B and C the Gland Plate Kit is supplied as an option. It allows easy and efficient connection of the necessary screening. See the Gland Plate Installation Instructions contained on the Document CD-ROM, supplied with the MICROMASTER 440.

### Screening without a Gland Plate

Should a Gland Plate not be available, then the inverter can be screened using the methodology shown in Fig. 2-14.

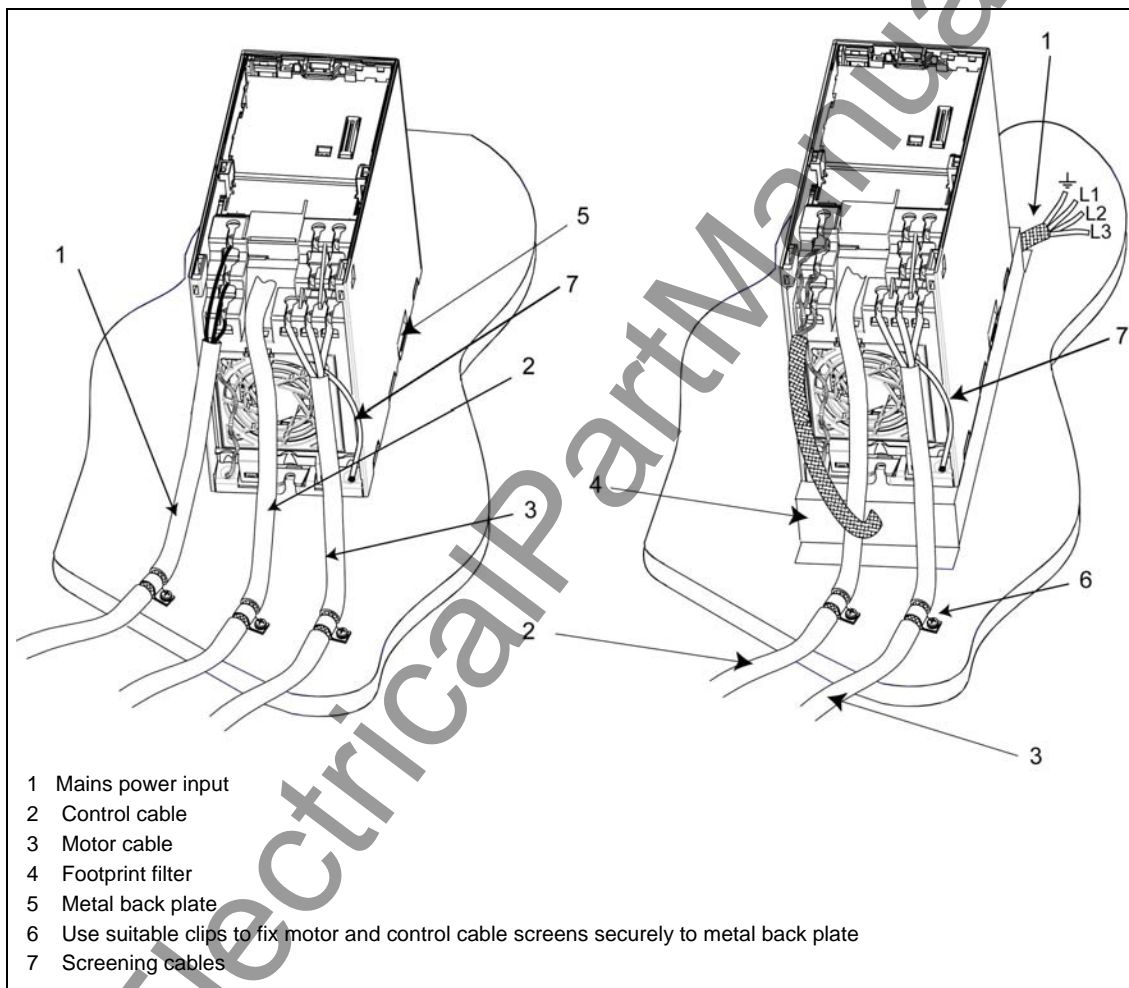


Fig. 2-14 Wiring Guidelines to Minimize the Effects of EMI

**Frame Sizes D and E**

The Gland Plate is factory fitted. If the installation conditions are restricted, the shield of the motor cable can also be attached outside the cabinet, as shown in Fig. 2-14, for example.

**Frame size F**

The gland plate for the control cables is factory-fitted.

Devices without filter: The shield of the motor cable must be attached outside the cabinet, as shown in Fig. 2-14, for example.

Devices with filter: The gland plate for the motor cable is factory-fitted.

**Frame Sizes FX and GX**

Connect the wire shields to the shield connection points shown in the connection drawing (see Fig. 2-9 and Fig. 2-10) .

Twist the shields of the motor cables and screw them to the PE connection for the motor cable.

When using an EMI filter, a power commutating choke is required. The wire shields should be fastened to the metallic mounting surface as close as possible to the components.

[www.ElectricalPartManuals.com](http://www.ElectricalPartManuals.com)

## 3 Functions

### This Section includes the following:

- Explanation of the MICROMASTER 440 parameters
- An overview of the parameter structure of MICROMASTER 440
- A description of the display and operator control elements and communications
- A block diagram of MICROMASTER 440
- An overview of the various ways of commissioning the MICROMASTER 440
- A description of the inputs and outputs
- Possibilities of controlling (open-loop and closed-loop) the MICROMASTER 440
- A description of the various functions of the MICROMASTER 440 and their implementation
- Explanation and information on the protective functions

3.1	Parameters .....	51
3.1.1	Setting / monitoring parameters and parameter attributes .....	51
3.1.2	Interconnecting signals (BICO technology) .....	57
3.1.2.1	Selecting the command source P0700 / selecting the setpoint source P1000.....	57
3.1.2.2	Selection of command/frequency setpoint P0719 .....	59
3.1.2.3	BICO technology.....	60
3.1.3	Data sets .....	63
3.1.4	Reference quantities .....	68
3.2	Operator panels for MICROMASTER.....	70
3.2.1	Description of the BOP (Basic Operator Panel) .....	70
3.2.2	Description of the AOP (Advanced Operator Panel) .....	71
3.2.3	Keys and their functions on the operator panel (BOP / AOP) .....	72
3.2.4	Changing parameters using the operator panel .....	73
3.3	Block diagram .....	74
3.4	Factory setting .....	75
3.5	Commissioning .....	77
3.5.1	50/60 Hz setting .....	79
3.5.2	Motor circuit .....	80
3.5.3	Quick commissioning .....	83
3.5.4	Calculating the motor / control data .....	88
3.5.5	Motor data identification.....	91
3.5.6	Magnetizing current .....	95
3.5.7	Commissioning the application .....	97
3.5.7.1	Serial Interface (USS).....	97
3.5.7.2	Selection of command source .....	98
3.5.7.3	Digital input (DIN).....	98
3.5.7.4	Digital output (DOUT) .....	99
3.5.7.5	Selection of frequency setpoint.....	100
3.5.7.6	Analog input (ADC).....	101

3.5.7.7	Analog output (DAC).....	102
3.5.7.8	Motor potentiometer (MOP).....	103
3.5.7.9	Fixed frequency (FF).....	104
3.5.7.10	JOG.....	105
3.5.7.11	Ramp function generator (RFG).....	106
3.5.7.12	Reference/limit frequencies.....	107
3.5.7.13	Inverter protection.....	108
3.5.7.14	Motor protection.....	108
3.5.7.15	Encoder.....	110
3.5.7.16	V/f control.....	111
3.5.7.17	Field-orientated control.....	113
3.5.7.18	Converter-specific Functions.....	118
3.5.7.19	Command and drive data set.....	127
3.5.7.20	Diagnostic parameters.....	130
3.5.7.21	End of commissioning.....	131
3.5.8	Series commissioning.....	132
3.5.9	Parameter reset to the factory setting.....	133
3.6	Inputs / outputs.....	135
3.6.1	Digital inputs (DIN).....	135
3.6.2	Digital outputs (DOUT).....	138
3.6.3	Analog inputs (ADC).....	140
3.6.4	Analog outputs (D/A converter).....	142
3.7	Communications.....	144
3.7.1	Universal serial interface (USS).....	146
3.7.1.1	Protocol specification and bus structure.....	148
3.7.1.2	The structure of net data.....	155
3.7.1.3	USS bus configuration via COM link (RS485).....	164
3.8	Fixed frequencies (FF).....	167
3.9	Motorized potentiometer (MOP).....	170
3.10	JOG.....	172
3.11	PID controller (technological controller).....	173
3.11.1	Closed-loop PID control.....	175
3.11.1.1	PID motorized potentiometer (PID-MOP).....	177
3.11.1.2	PID fixed setpoint (PID-FF).....	178
3.11.1.3	PID dancer roll control.....	179
3.12	Setpoint channel.....	181
3.12.1	Summation and modification of the frequency setpoint (AFM).....	181
3.12.2	Ramp-function generator (RFG).....	183
3.12.3	OFF/braking functions.....	186
3.12.4	Manual / automatic operation.....	189
3.13	Free function blocks (FFB).....	191
3.14	Motor holding brake (MHB).....	196
3.15	Electronic brakes.....	202
3.15.1	DC braking.....	202
3.15.2	Compound braking.....	205
3.15.3	Dynamic braking.....	206
3.16	Automatic restart.....	211
3.17	Flying restart.....	213

3.18	Closed-loop Vdc control.....	215
3.18.1	Vdc_max controller .....	215
3.18.2	Kinetic buffering (Vdc_min controller).....	218
3.19	Positioning down ramp .....	219
3.20	Monitoring functions / messages .....	221
3.20.1	General monitoring functions / messages .....	221
3.20.2	Load torque monitoring .....	223
3.21	Thermal motor protection and overload responses .....	227
3.21.1	Thermal motor model.....	229
3.21.2	Temperature sensor.....	230
3.22	Power module protection .....	232
3.22.1	General overload monitoring .....	232
3.22.2	Thermal monitoring functions and overload responses.....	233
3.23	Open-loop/closed-loop control technique .....	235
3.23.1	V/f control.....	235
3.23.1.1	Voltage boost.....	237
3.23.1.2	Slip compensation.....	239
3.23.1.3	V/f resonance damping .....	240
3.23.1.4	V/f open-loop control with flux current control (FCC).....	241
3.23.1.5	Current limiting (Imax controller).....	242
3.23.2	Vector control.....	243
3.23.2.1	Vector control without speed encoder (SLVC) .....	245
3.23.2.2	Vector control with speed encoder (VC).....	247
3.23.2.3	Speed controller.....	248
3.23.2.4	Closed-loop torque control.....	253
3.23.2.5	Limiting the torque setpoint.....	254

**WARNING**

- MICROMASTER drive inverters operate with high voltages.
- When electrical equipment is operated, then specific parts of this equipment are at hazardous voltage levels.
- The following terminals can carry dangerous voltages even if the inverter is inoperative:
  - ◆ the power supply L/L1, N/L2, L3 resp. U1/L1, V1/L2, W1/L3
  - ◆ the motor terminals U, V, W resp. U2, V2, W2
  - ◆ and depending on the frame size the terminals DC+/B+, DC-, B-, DC/R+ resp. DCPS, DCNS, DCPA, DCNA
- Emergency switching-off devices in compliance with EN 60204 IEC 204 (VDE 0113) must remain functional in all operating modes of the control device. When the Emergency switching-off device is reset, then it is not permissible that the equipment runs-up again in an uncontrolled or undefined way.
- In cases and situations where short-circuits in the control device can result in significant material damage or even severe bodily injury (i.e. potentially hazardous short-circuits), then additional external measures or devices/equipment must be provided in order to ensure or force operation without any potential hazards, even if a short-circuit occurs (e.g. independent limit switches, mechanical interlocks etc.).
- Certain parameter settings can mean that the drive inverter automatically restarts after the power supply voltage fails and then returns.
- The motor parameters must be precisely configured in order to ensure perfect motor overload protection.
- The drive inverter provides internal motor overload protection according to UL508C, Section 42. I<sup>2</sup>t monitoring is enabled in the default setting (refer to P0610 and P0335). The motor overload protection can also be guaranteed using an external PTC or KTY84.
- This equipment is suitable for use in a circuit capable of delivering not more than 10,000 (Frame Sizes A to C) or 42,000 (Frame Sizes D to GX) symmetrical amperes (rms), for a maximum voltage of 230 V / 460 V / 575 V when protected by an H, J or K type fuse, a circuit breaker or self-protected combination motor controller (for more details see Appendix F).
- The drive unit may not be used as 'Emergency switching-off device' (refer to EN 60204, 9.2.5.4).

**CAUTION**

Only qualified personnel may commission (start-up) the equipment. Safety measures and warnings must be always extremely carefully observed and fulfilled.

## 3.1 Parameters

### 3.1.1 Setting / monitoring parameters and parameter attributes

The drive inverter is adapted to the particular application using the appropriate parameters. This means that each parameter is identified by a parameter number, parameter text and specific attributes (e.g. readable, can be written into, BICO attribute, group attribute etc.). Within any one particular drive system, the parameter number is unique. On the other hand, an attribute can be assigned a multiple number of times so that several parameters can have the same attribute.

For MICROMASTER, parameters can be accessed using the following operator units:

- BOP (option)
- AOP (option)
- PC-based commissioning (start-up) tool "Drive Monitor" or "STARTER". These PC-based tools are supplied on the CD-ROM.

The parameter types are the main differentiating feature of the parameters.

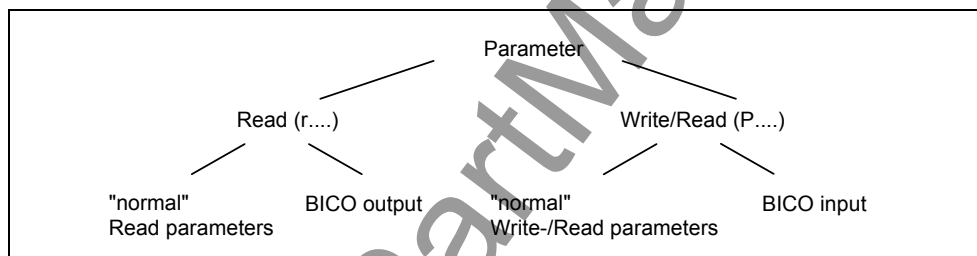


Fig. 3-1 Parameter types

### Setting parameters

Parameters which can be written into and read – "P" parameters

These are activated/de-activated in the individual functions or parameters directly influence the behavior of a function. The value of this parameter is saved in a non-volatile memory (EEPROM) as long as the appropriate option was selected (non-volatile data save). Otherwise, these values are saved in the non-volatile memory (RAM) of the processor, which are lost after power failure or power-off/power-on operations.

#### Notation:

- P0927 setting parameter 927
  - P0748.1 setting parameter 748, bit 01
  - P0719[1] setting parameter 719 index 1
  - P0013[0...19] setting parameter 13 with 20 indices (indices 0 to 19)
- Abbreviated notation
- P0013[20] setting parameter 13 with 20 indices (indices 0 to 19)

## Monitoring parameters

These can only be read – "r" parameters

These parameters are used to display internal quantities, for example states and actual values. These parameters are absolutely necessary, especially for diagnostics.

### Notation:

r0002	monitoring parameter 2
r0052.3	monitoring parameter 52, bit 03
r0947[2]	monitoring parameter 947 index 2
r0964[0...4]	monitoring parameter 964 with 5 indices (indices 0 to 4)
Abbreviated notation	
r0964[5]	monitoring parameter 964 with 5 indices (indices 0 to 4)

### NOTE

- A parameter (e.g. P0013[20]) with x consecutive elements (in this case: 20) is defined using an index. x is defined by the numerical index value. When transferred to a parameter this means that an indexed parameter can assume several values. The values are addressed via the parameter number including the index value (e.g. P0013[0], P0013[1], P0013[2], P0013[3], P0013[4], ...). Index parameters, for example, are used for:

- Drive data sets
- Command data sets
- Sub-functions





P0013[0]	
P0013[1]	
P0013[2]	
⋮	
P0013[18]	
P0013[19]	

In addition to the parameter number and parameter text, every setting and monitoring parameter has different attributes which are used to individually define the properties/characteristics of the parameter. The attributes are listed in the following Table which are used for MICROMASTER.

Table 3-1 Parameter attributes

Attribute group	Attribute	Description
Data types		The data type of a parameter defines the maximum possible value range. 3 data types are used for MICROMASTER. They either represent an unsigned integer value (U16, U32) or a floating-point value (float). The value range is frequently restricted by a minimum, maximum value (min, max) or using drive inverter/motor quantities.
	U16	Unsigned, integer value with a size of 16 bits, max. value range: 0 .... 65535
	U32	Unsigned, integer value with a size of 32 bits max. value range: 0 .... 4294967295
	Float	A simple precise floating point value according to the IEEE standard format max. value range: $-3.39e^{+38}$ – $+3.39e^{+38}$

Attribute group	Attribute	Description
Value range		The value range, which is specified as a result of the data type, is restricted/limited by the minimum, maximum value (min, max) and using drive inverter/motor quantities. Straightforward commissioning (start-up) is guaranteed in so much that the parameters have a default value. These values (min, def, max) are permanently saved in the drive inverter and cannot be changed by the user.
	-	No value entered (e.g.: "r parameter")
	Min	Minimum value
	Def	Default value
	Max	Maximum value
Unit		For MICROMASTER, the units of a particular parameter involve the physical quantity (e.g. m, s, A). Quantities are measurable properties/characteristics of physical objects, operations, states and are represented using characters of a formula (e.g. V = 9 V).
	-	No dimension
	%	Percentage
	A	Ampere
	V	Volt
	Ohm	Ohm
	us	Microseconds
	ms	Milliseconds
	s	Seconds
	Hz	Hertz
	kHz	Kilohertz
	1/min	Revolutions per minute [RPM]
	m/s	Meters per second
	Nm	Newton meter
	W	Watt
	kW	Kilowatt
	Hp	Horse power
	kWh	Kilowatt hours
	°C	Degrees Celsius
	m	Meter
kg	Kilograms	
°	Degrees (angular degrees)	
Access level		The access level is controlled using parameter P0003. In this case, only those parameters are visible at the BOP or AOP, where the access level is less than or equal to the value assigned in parameter P0003. On the other hand, for DriveMonitor and STARTER, only access levels 0 and 4 are relevant. For example, parameters with access level 4 cannot be changed if the appropriate access level has not been set. The following access levels are implemented in the family of MICROMASTER drive units:
	0	User-defined parameter list (refer to P0013)
	1	Standard access to the most frequently used parameters
	2	Extended access, e.g. to drive inverter I/O functions
	3	Expert access only for experienced users
	4	Service access only for authorized service/maintenance personnel – with password protection.
		As far as the ability to visualize the parameters is concerned, the group assignment of the individual parameters must be taken into account. Parameter P0004 is used for the control (refer to the Grouping).

Attribute group	Attribute	Description
Grouping		The parameters are sub-divided into groups according to their functionality. This increases the transparency and allows a parameter to be quickly searched for. Furthermore, parameter P0004 can be used to control the ability to be visualized for the BOP / AOP. Main parameter area:
	ALWAYS	0 all parameters
	INVERTER	2 drive inverter parameters 0200 .... 0299
	MOTOR	3 motor parameters 0300 .... 0399 and 0600 .... 0699
	ENCODER	4 speed encoder 0400 .... 0499
	TECH_APL	5 technical applications / units 0500 .... 0599
	COMMANDS	7 control commands, digital I/O 0700 .... 0749 and 0800 .... 0899
	TERMINAL	8 Analog inputs/outputs 0750 .... 0799
	SETPOINT	10 Setpoint channel and ramp-function gen. 1000 .... 1199
	FUNC	12 Drive inverter functions 1200 .... 1299
	CONTROL	13 Motor open-loop/closed-loop control 1300 .... 1799
	COMM	20 Communications 2000 .... 2099
	ALARMS	21 Faults, warnings, monitoring functions" 2100 .... 2199
	TECH	22 Technological controller (PID controller) 2200 .... 2399
BICO		Description for Binector Input (BI), Binector Output (BO), Connector Input (CI), Connector Output (CO) and Connector Output / Binector Output (CO/BO), refer to Section 3.1.2.3
	BI	Binector Input
	BO	Binector Output
	CI	Connector Input
	CO	Connector Output
	CO/BO	Connector Output / Binector Output
Data sets		Description for the command data set (CDS) and drive data set (DDS) refer to Section 3.1.3
	CDS	Command data set
	DDS	Drive data set
Change state		"P" parameters can only be changed depending on the drive state. The parameter value is not accepted if the instantaneous state is not listed in the parameter attribute "Change state". For instance, the commissioning (start-up) parameter P0010 with the attribute "CT" can only be changed in quick start-up "C" or ready "T" but not in run "U".
	C	Quick commissioning (start-up)
	U	Operation (run)
	T	Ready
QC.		This parameter attribute identifies as to whether the parameter is included in the quick commissioning (start-up) (P0010 = 1).
	No	The parameter is not included in the quick commissioning (start-up)
	Yes	The parameter is included in the quick commissioning (start-up)
Active		This attribute is only of importance in conjunction with a BOP. The "Immediate" attribute indicates that this value is already accepted when scrolling (when changing the value with  or  ). Especially parameters which are used for optimization functions have this property (e.g. constant voltage boost P1310 or filter time constants). On the other hand, for parameters with the attribute "After actuation", the value is only accepted after first actuating the key  . These include, for example, parameters where the parameter value can have different settings/meanings (e.g. selecting the frequency setpoint source P1000).
	Immediately	The value becomes valid by either scrolling with  or 
	After actuation	The value is only accepted by pressing 

The attributes and groups are shown, in the parameter list, in the header line of the parameter. This is shown as an example in Fig. 3-2 using parameter P0305.

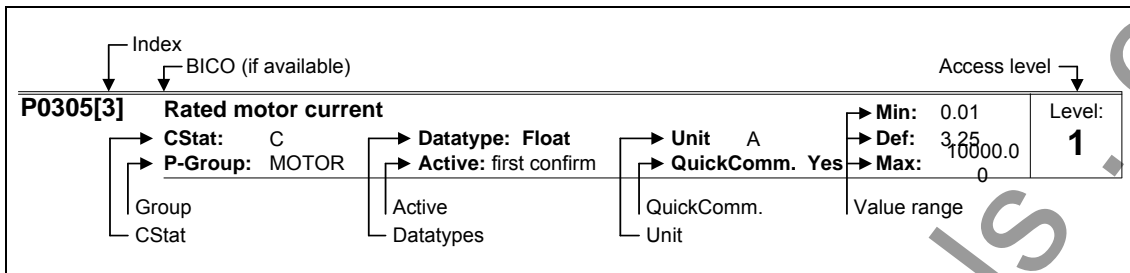


Fig. 3-2 Header line for parameter P0305

The interrelationship between access level P0003 and the grouping P0004 is schematically shown in Fig. 3-3.

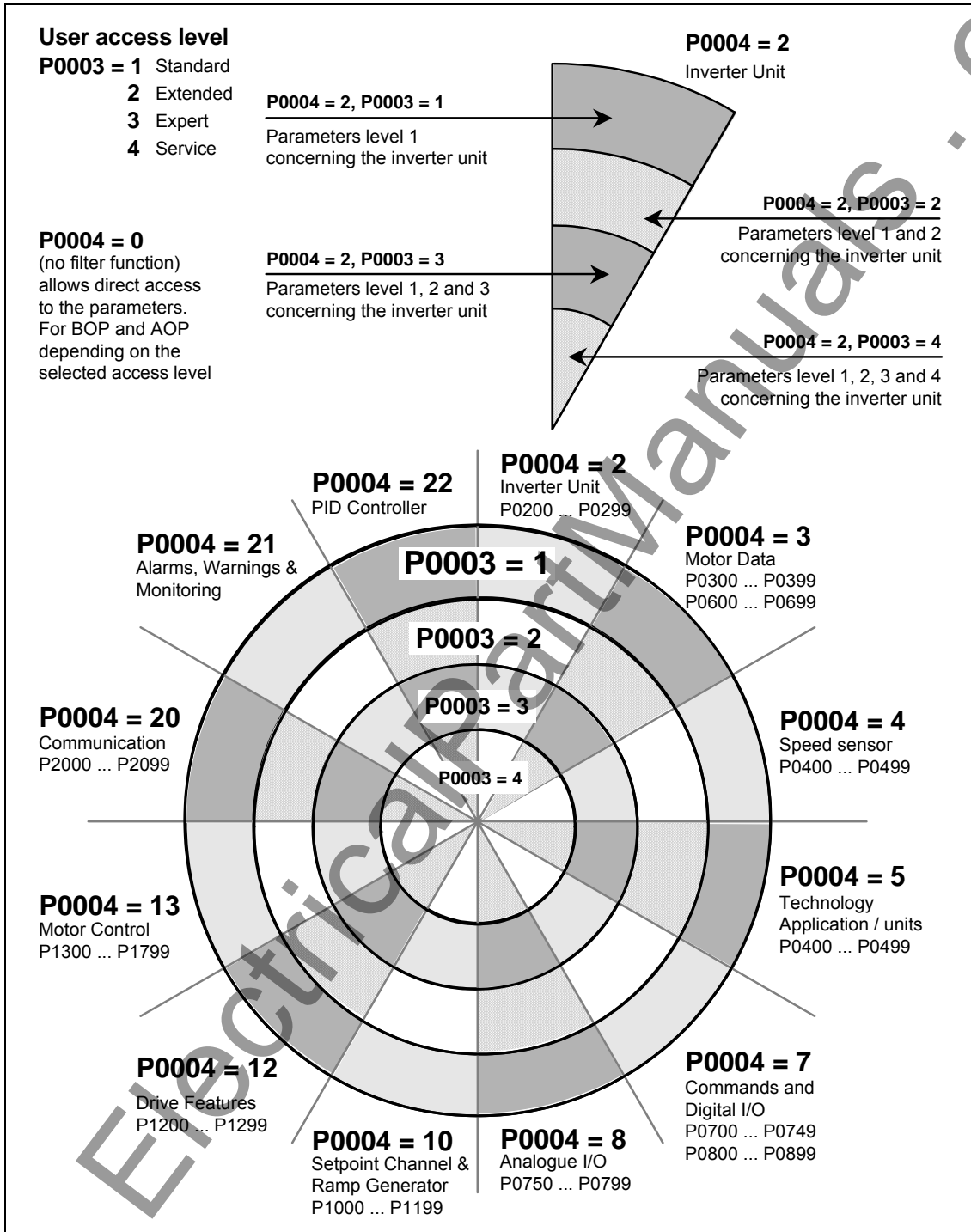


Fig. 3-3 ◆ Parameter grouping / access

### 3.1.2 Interconnecting signals (BICO technology)

A state-of-the-art drive unit must be able to interconnect internal and external signals (setpoint / actual values and control / status signal). This interconnection functionality must have a high degree of flexibility in order to be able to adapt the drive to new applications. Further, a high degree of usability is required, which also fulfills standard applications. This is the reason that within the MICROMASTER series of drive units, BICO technology (→ flexibility) and fast parameterization using parameters P0700 / P1000 (→ usability) or P0719 (→ combination P0700/P1000) have been introduced to be able to fulfill both of these requirements.

#### 3.1.2.1 Selecting the command source P0700 / selecting the setpoint source P1000

The following parameters can be used to quickly interconnect setpoints and control signals:

- P0700 "Selection of command source"
- P1000 "Selection of setpoint source"

These parameters are used to define via which interface the drive inverter receives the setpoint or the power-on/power-off command. The interfaces, listed in Table 3-2 can be selected for the command source P0700.

Table 3-2 Parameter P0700

Parameter values	Significance / command source
0	Factory default
1	BOP (operator panel, refer to Section 3.2.1)
2	Terminal strip
4	USS on BOP link
5	USS on COM link
6	CB on COM link

The following internal or external sources / interfaces can be selected for the frequency setpoint source P1000. In addition to the main setpoint (1<sup>st</sup> position), a supplementary setpoint (2<sup>nd</sup> position) can be selected (refer to Table 3-3).

Table 3-3 Parameter P1000

Parameter values	Significance	
	Main setpoint source	Supplementary setpoint source
0	No main setpoint	-
1	MOP setpoint (motorized potentiometer)	-
2	Analog setpoint	-
3	Fixed frequency	-
4	USS on BOP link	-
5	USS on COM link	-
6	CB on COM link	-
7	Analog setpoint 2	-
10	No main setpoint	MOP setpoint
11	MOP setpoint	MOP setpoint
12	Analog setpoint	MOP setpoint
..	..	..
..	..	..
..	..	..
77	Analog setpoint 2	Analog setpoint 2

**NOTE**

- Communications between the AOP and MICROMASTER are established using the USS protocol. The AOP can be connected to both the BOP link (RS 232) as well as at the COM link interface (RS 485) of the drive inverter. If the AOP is to be used as command source or setpoint source then for parameter P0700 or P1000, either "USS on BOP link" or "USS on COM link" should be selected.
- The complete list of all of the setting possibilities can be taken from the parameter list (refer to parameter list P1000).
- Parameters P0700 and P1000 have the following default settings:
  - a) P0700 = 2 (terminal strip)
  - b) P1000 = 2 (analog setpoint)

In this case, the selection of the command source is made independently of the selection of the frequency setpoint source. This means that the source to enter the setpoint does not have to match the source to enter the power-on/power-off command (command source). This means, for example, that the setpoint (P1000 = 4) can be connected via an external device which is connected to the BOP link interface via USS and the control (ON/OFF command, etc.) is entered via digital inputs (terminals, P0700 = 2).

**CAUTION**

- When P0700 or P1000 are modified, then the frequency inverter also changes the subordinate BICO parameters (refer to the parameter list for P0700 or P1000 in the appropriate tables)
- There is no prioritization (priority assignment) between direct BICO parameterization and P0700/P1000. The last modification is valid.

### 3.1.2.2 Selection of command/frequency setpoint P0719

Parameter P0719 represents a combination of the functionalities of the two parameters P0700 and P1000. Here, it is possible to changeover the command source as well as also the frequency setpoint source via a parameter change. Contrary to P0700 and P1000, for parameter P0719, the subordinate (lower-level) BICO parameters are not changed. This characteristic/feature is especially used by PC tools in order to briefly retrieve the control authority for the drive without having to change the existing BICO parameterization. Parameter P0719 "Selection of command/frequency setpoint" comprises the command source (Cmd) and the frequency setpoint (setpoint).

Table 3-4 Parameter P0719

Parameter values	Significance	
	Command source	Setpoint source (frequency source)
0	Cmd=BICO parameter	Setpoint = BICO parameter
1	Cmd=BICO parameter	Setpoint = MOP setpoint
2	Cmd=BICO parameter	Setpoint = Analog
3	Cmd=BICO parameter	Setpoint = Fixed frequency
4	Cmd=BICO parameter	Setpoint = USS BOP link
5	Cmd=BICO parameter	Setpoint = USS COM link
6	Cmd=BICO parameter	Setpoint = CB COM link
10	Cmd=BOP	Setpoint = BICO Param
11	Cmd=BOP	Setpoint = MOP setpoint
12	Cmd=BOP	Setpoint = Analog
..	..	..
..	..	..
64	Cmd=CB COM link	Setpoint = USS BOP link
66	Cmd=CB COM link	Setpoint = USS COM link

#### NOTE

- The complete list of all of the possible settings can be taken from the parameter list (refer to the parameter list, P0719).
- Contrary to parameter P0700 and P1000, subordinate BICO parameters are not changed for parameter P0719. This characteristic/feature can be used during service if the control authority must be briefly and quickly re-assigned (e.g. selecting and executing the motor data identification routine using a PC-based tool).

### 3.1.2.3 BICO technology

Using BICO technology (English: Binector Connector Technology), process data can be freely interconnected using the "standard" drive parameterization. In this case, all values which can be freely interconnected (e.g. frequency setpoint, frequency actual value, current actual value, etc.) can be defined as "Connectors" and all digital signals which can be freely interconnected (e.g. status of a digital input, ON/OFF, message function when a limit is violated etc.) can be defined as "Binectors".

There are many input and output quantities as well as quantities within the closed-loop control which can be interconnected in a drive unit. It is possible to adapt the drive to the various requirements using BICO technology.

A binector is a digital (binary) signal without any units and which can either have the value 0 or 1. Binectors always refer to functions whereby they are sub-divided into binector inputs and binector outputs (refer to Fig. 3-4). In this case, the binector input is always designated using a "P" parameter with attribute "BI" (e.g.: P0731 BI: Function, digital output 1), while the binector output is always represented using an "r" parameter with attribute "BO" (e.g.: r0751 BO: ADC status word).

As can be seen from the examples above, the binector parameters have the following abbreviations in front of the parameter names:

➤ **BI Binector Input, signal receiver ("P" parameters)**

→ The BI parameter can be interconnected with a binector output as source, by entering the parameter number of the binector output (BO parameter) as value in the BI parameter (e.g.: Interconnecting the "BO" parameter r0751 with "BI" parameter P0731 → P0731 = 751).

➤ **BO Binector Output, signal source ("r" parameters)**

→ The BO parameter can be used as source for BI parameters. For the particular interconnection the BO parameter number must be entered into the BI parameter (e.g.: Interconnecting the "BO" parameter r0751 with "BI" parameter P0731 → P0731 = 751).


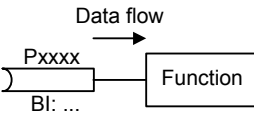

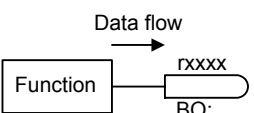
Abbreviation and symbol	Name	Function
BI 	Binector input (signal receiver)	
BO 	Binector output (signal source)	

Fig. 3-4 Binectors

A connector is a value (16 or 32 bit), which can include a normalized quantity (without dimension) as well as also a quantity with associated units. Connectors always refer to functions whereby they are sub-divided into connector inputs and connector outputs (refer to Fig. 3-5). Essentially the same as the binectors, the connector inputs are characterized by a "P" parameter with attribute "CI" (e.g.: P0771 CI: D/A converter); while the connector outputs are always represented using an "r" parameter with attribute "CO" (e.g.: r0021 CO: Smoothed output frequency).

As can be seen from the examples above, connector parameters have the following abbreviations in front of the parameter names:

➤ **CI Connector Input, signal sink ("P" parameters)**

→ The CI parameter can be interconnected with a connector output as source, by entering the parameter number of the connector output (CO parameter) as value in the CI parameter (e.g.: P0771 = 21).

➤ **CO Connector Output, signal source ("r" parameters)**

→ The CO parameter can be used as source for CI parameters. For the particular interconnection, the CO parameter number must be entered in the CI parameter (e.g.: P0771 = 21).

Further, MICROMASTER has "r" parameters where several binector outputs are combined in a word (e.g.: r0052 CO/BO: Status word 1). This feature reduces, on one hand, the number of parameters and simplifies parameterization via the serial interface (data transfer). This parameter is further characterized by the fact that it does not have any units and each bit represents a digital (binary) signal.

As can be seen from the examples of parameters, these combined parameters have the following abbreviation in front of the parameter names:

➤ **CO/BO Connector Output / Binector Output, signal source ("r" parameters)**

→ CO/BO parameters can be used as source for CI parameters and BI parameters:

- In order to interconnect all of the CO/BO parameters, the parameter number must be entered into the appropriate CI parameter (e.g.: P2016[0] = 52).
- When interconnecting a single digital signal, in addition to the CO/BO parameter number, the bit number must also be entered into the BI parameter (e.g.: P0731 = 52.3)


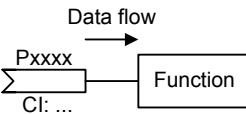

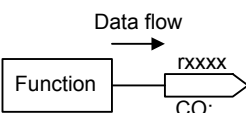

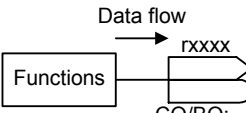
Abbreviation and symbol	Name	Function
CI 	Connector input (signal receiver)	
CO 	Connector output (signal source)	
CO BO 	Binector/connector output (signal source)	

Fig. 3-5 Connectors

In order to interconnect two signals, a BICO setting parameter (signal receiver) must be assigned the required BICO monitoring parameter (signal source). A typical BICO interconnection is shown using the following examples (refer to Fig. 3-6).

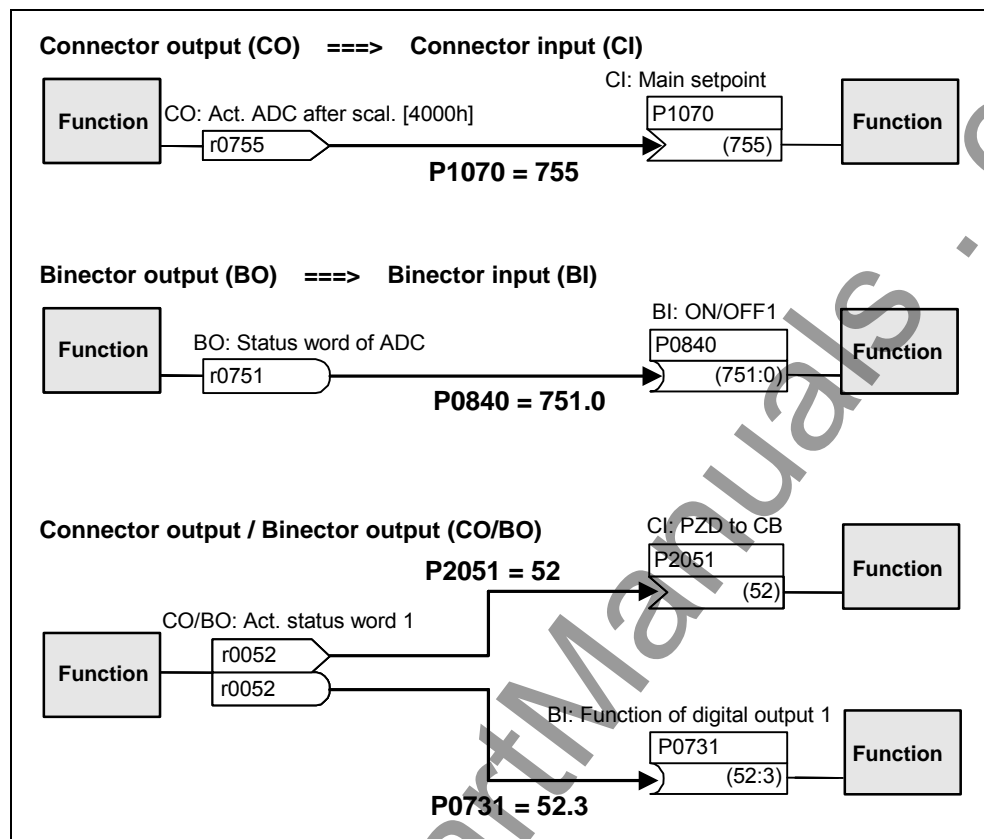


Fig. 3-6 BICO connections (examples)

**NOTE**

BICO parameters with the CO, BO or CO/BO attributes can be used a multiple number of times.

### 3.1.3 Data sets

For many applications it is advantageous if several parameters can be simultaneously changed, during operation or in the ready state, using an external signal.

#### Examples:

- The drive inverter should be switched-over from motor 1 to motor 2.

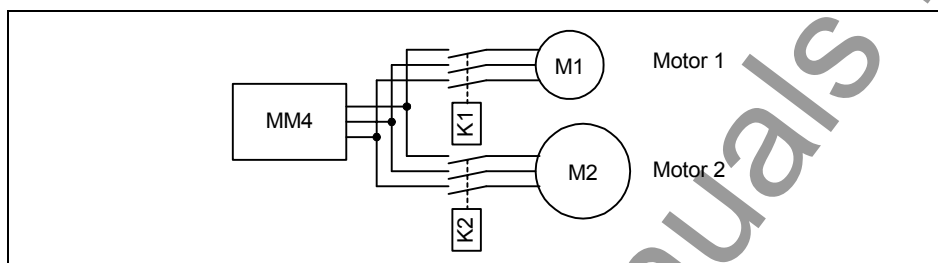


Fig. 3-7 Example: Changeover from motor 1 to motor 2

- The control source (e.g. terminal → BOP) or setpoint (frequency) source (e.g. ADC → MOP) should be changed-over using a terminal signal (e.g. DIN4) as function of an external event (e.g. the higher-level control unit fails). A typical example in this case is a mixer, which may not come to an uncontrolled stop when the control fails.

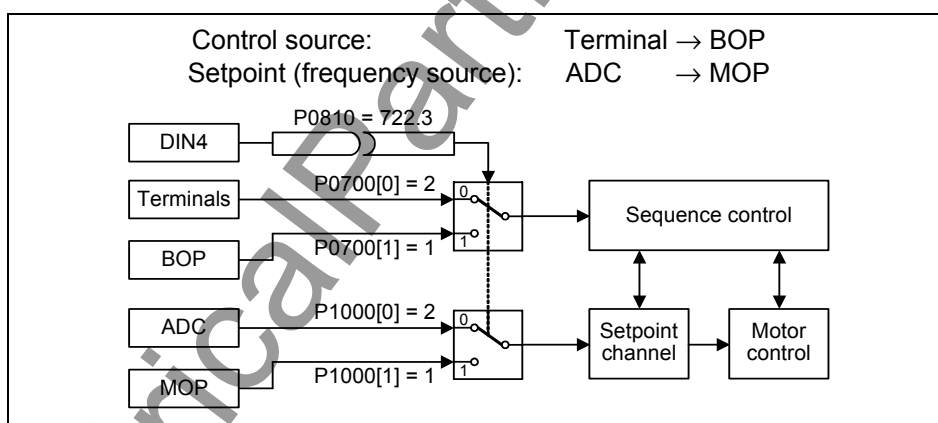


Fig. 3-8 Example: Changing-over between the control and setpoint (frequency) source

This functionality can be elegantly implemented using indexed parameters (refer to Section 3.1.1). In this case, as far as the functionality is concerned, the parameters are combined to form groups / data sets and are indexed. By using indexing, several different settings can be saved for each parameter which can be activated by changing-over the data set (i.e. toggling between data sets).

The following data sets apply:

- CDS Command Data Set
- DDS Drive Data Set

3 independent settings are possible for each data set. These settings can be made using the index of the particular parameter:

CDS1 ... CDS3

DDS1 ... DDS3

Those parameters (connector and binector inputs) which are used to control the drive and enter a setpoint, are assigned to the command data set (CDS). The signal sources for the control commands and setpoints are interconnected using BICO technology (refer to Section 3.1.2.3). In this case, the connector and binector inputs are assigned as signal sources corresponding to the connector and binector outputs. A command data set includes:

➤ **Command sources and binector inputs for control commands (digital signals) e.g.:**

- ◆ Selects the command source P0700
- ◆ ON/OFF1 P0840
- ◆ OFF2 P0844
- ◆ Enable JOG right P1055
- ◆ Enable JOG left P1056

➤ **Setpoint sources and connector inputs for setpoints (analog signals) e.g.:**

- ◆ Selection of frequency setpoint P1000
- ◆ Selection of main setpoint P1070
- ◆ Selection of additional setpoint P1075

The parameters, combined in a command data set, are designated with [x] in the parameter list in the index field.

Index:

Pxxxx[0] : 1<sup>st</sup> command data set (CDS)

Pxxxx[1] : 2<sup>nd</sup> command data set (CDS)

Pxxxx[2] : 3<sup>rd</sup> command data set (CDS)

---

**NOTE**

A complete list of all of the CDS parameters can be taken from the parameter list.

---

It is possible to parameterize up to three command data sets. This makes it easier to toggle between various pre-configured signal sources by selecting the appropriate command data set. A frequent application involves, for example, the ability to toggle between automatic and manual operation.

MICROMASTER has an integrated copy function which is used to transfer command data sets. This can be used to copy CDS parameters corresponding to the particular application. The copy operation is controlled with P0809 as follows (refer to Fig. 3-9):

1. P0809[0] = Number of the command data set which is to be copied (source)
2. P0809[1] = Number of the command data set into which data is to be copied (target)
3. P0809[2] = 1 → Copying is started  
Copying has been completed, if P0809[2] = 0.

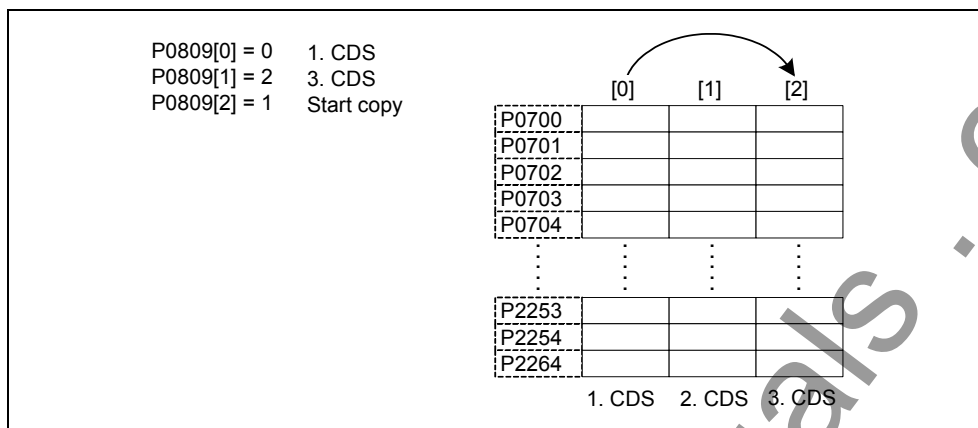


Fig. 3-9 Copying from CDS

The command data sets are changed-over using the BICO parameter P0810 and P0811, whereby the active command data set is displayed in parameter r0050 (refer to Fig. 3-10). Changeover is possible both in the "Read" as well as in the "Run" states.

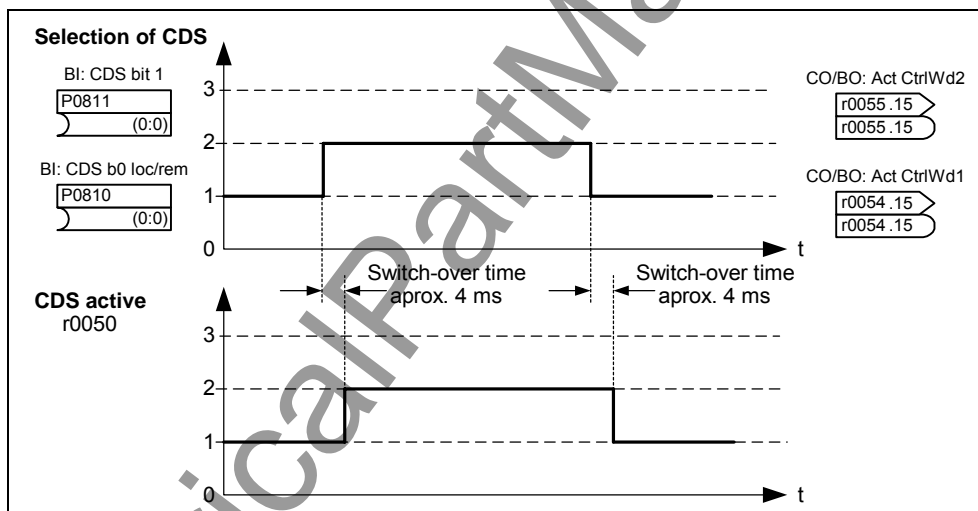


Fig. 3-10 Changing-over CDS

The drive data set (DDS) contains various setting parameters which are of significance for the open-loop and closed-loop control of a drive:

- **Motor and encoder data, e.g.:**
  - ◆ Select motor type P0300
  - ◆ Rated motor voltage P0304
  - ◆ Main inductance P0360
  - ◆ Select encoder type P0400
- **Various closed-loop control parameters, e.g.:**
  - ◆ Fixed frequency 1 P1001
  - ◆ Min. frequency P1080
  - ◆ Ramp-up time P1120
  - ◆ Control mode P1300

The parameters, combined in a drive data set, are designated with an [x] in the parameter list in the index field:

- Pxxxx[0] : 1<sup>st</sup> drive data set (DDS)
- Pxxxx[1] : 2<sup>nd</sup> drive data set (DDS)
- Pxxxx[2] : 3<sup>rd</sup> drive data set (DDS)

**NOTE**

A complete list of all of the DDS parameters can be taken from the parameter list.

It is possible to parameterize several drive data sets. This makes it easier to toggle between various drive configurations (control mode, control data, motors) by selecting the appropriate drive data set.

Just like the command data sets, it is possible to copy drive data sets within the MICROMASTER. P0819 is used to control the copy operation as follows:

1. P0819[0] = Number of the drive data set which is to be copied (source)
2. P0819[1] = Number of the drive data set into which data is to be copied (target)
3. P0819[2] = 1 → Copying is started  
Copying has been completed, if P0819[2] = 0.

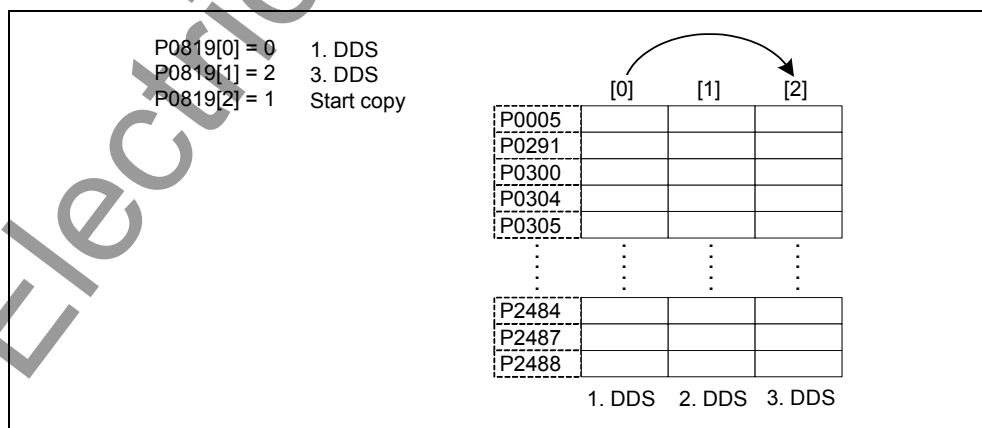


Fig. 3-11 Copying from DDS

Drive data sets are changed-over using the BICO parameter P0820 and P0821 whereby the active drive data set is displayed in parameter r0051 (refer to Fig.

3-12). Drive data sets can only be changed-over in the "Ready" state and this takes approx. 50 ms.

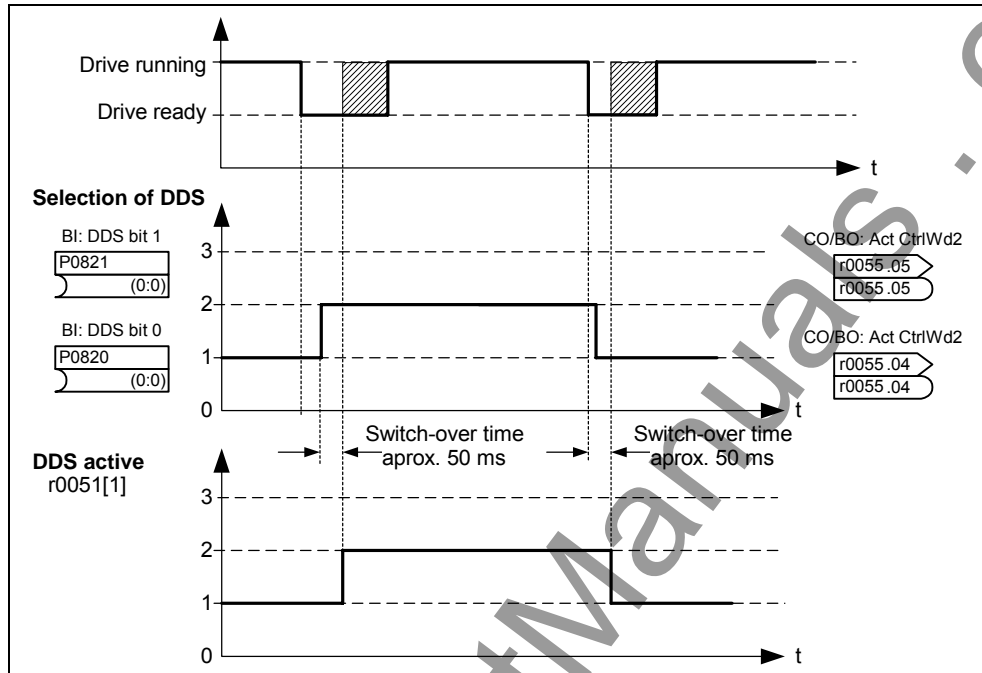


Fig. 3-12 Changing-over DDS

### 3.1.4 Reference quantities

Parameter range: P2000 – r2004

Physical quantities are normalized or de-normalized by the frequency inverter when data is output or is being entered. This conversion is undertaken by the particular interface using the reference quantities. The normalization / de-normalization is carried-out for the following interfaces:

Table 3-5 Normalized interfaces

Interface	100 %
Analog input	
Current input	20 mA
Voltage input	10 V
Analog output	
Current output	20 mA
Voltage output	10 V
USS	4000 h
CB	4000 h

Further, for a BICO connection, a normalization is carried-out if the connector output (CO) represents a physical quantity and the connector input (CI) a normalized (percentage) quantity (e.g. PID controller). De-normalization is carried-out if the inverse situation exists. This normalization / de-normalization should be carefully taken into consideration, especially for the free function blocks (FFBs).

Reference quantities (normalization quantities) are intended to allow setpoint and actual value signals to be represented in a standard fashion (normalization / de-normalization of physical quantities such as setpoint and actual frequency). This also applies for permanently set parameters that are entered as a "percentage". A value of 100 % corresponds to a process data value PZD of 4000 h (USS or CB) – or a current / voltage value of 20 mA / 10 V (analog input / output). The following reference parameters and permanently saved reference values are available:

Table 3-6 Normalization functions

Parameter	Designation	Value (100 % / 4000 h)	Units
P2000	Reference frequency	P2000	Hz
P2001	Reference voltage	P2001	V
P2002	Reference current	P2002	A
P2003	Reference torque	P2003	Nm
r2004	Reference power	$\pi * P2000 * P2003$	kW
-	Reference speed	$P2000 * 60 / r0313$	RPM
-	Reference temperature	100 °C	°C
-	Reference energy	100 kWh	kWh

### Example

Using the reference frequency P2000 as example, normalization / de-normalization is demonstrated via the serial interface "USS at BOP link".

If the connection between two BICO parameters is closed (directly using the BICO parameters or indirectly using P0719 or P1000), that have different representation types (normalized representation (hex) or physical representation (Hz)), then in the frequency inverter, the following normalization is made to the target value:

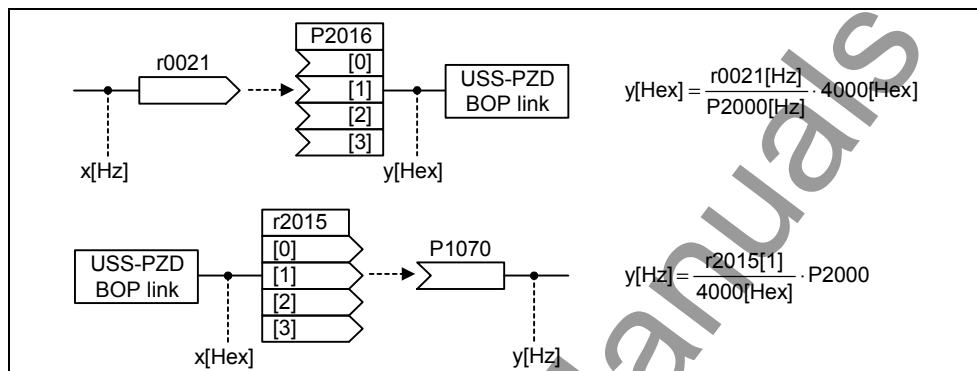


Fig. 3-13 Normalization / de-normalization

### Note

- Analog values are limited to 10 V or 20 mA. A maximum of 100 % referred to the corresponding reference values can be output / entered as long as no DAC/ADC scaling is made (factory setting).
- Setpoints and actual value signals via serial interface:
  - ◆ When transferring using the PZD part, they are limited to the value 7FFF h. This is the reason that the maximum value is 200 % referred to the reference value.
  - ◆ When transferring data using the PKW part, they are transferred dependant on the data type and the units.
- Parameter P1082 (max. frequency) limits the frequency in the frequency inverter independent of the reference frequency. When changing P1082 (factory setting: 50 Hz), this is the reason that P2000 should always be adapted (factory setting: 50 Hz). If, e.g. for a NEMA motor, the parameter is set to 60 Hz, and no changes are made regarding P2000, then the analog setpoint / actual value is limited to 100 % or a setpoint / actual value signal at 4000 h is limited to 50 Hz!

## 3.2 Operator panels for MICROMASTER

MICROMASTER drive units can be optionally equipped with a BOP (Basic Operator Panel) or AOP (Advanced Operator Panel). The AOP distinguishes itself as a result of a plain text display which simplifies operator control, diagnostics as well as also commissioning (start-up).

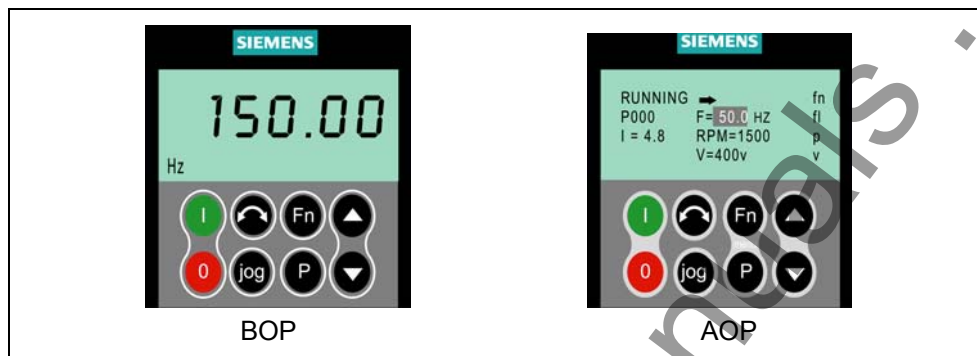


Fig. 3-14 Operator panels

### 3.2.1 Description of the BOP (Basic Operator Panel)

The BOP, available as option, allows drive inverter parameters to be accessed. In this case, the Status Display Panel (SDP) must be removed and the BOP either inserted or connected in the door of a cabinet using a special mounting kit (Operator panel door mounting set) (refer to the Attachment A).

Parameter values can be changed using the BOP. This allows the MICROMASTER drive unit to be set-up for a particular application. In addition to the keys (refer to Section 3.2.3), it includes a 5-digit LCD display on which the parameter numbers rxxxx and Pxxxx, parameter values, parameter units (e.g. [A], [V], [Hz], [s]), alarm Axxxx or fault messages Fxxxx as well as setpoints and actual values.

#### NOTE

- Contrary to the AOP, for the BOP, parameters do not have to be set or taken into consideration when establishing the communications between the BOP and drive inverter.
- A BOP does not have a local memory. This means that it is not possible to save a parameter set on the BOP.

### 3.2.2 Description of the AOP (Advanced Operator Panel)

An AOP (this is available as option) has the following additional functions with respect to a BOP:

- Multi-language and multi-line plain text display
- Units are additionally displayed, such as [Nm], [°C], etc.
- Active parameters, fault messages, etc. are explained
- Diagnostics menu to support troubleshooting
- The main menu is directly called by simultaneously pressing keys Fn and P
- Timer with 3 switching operations per entry
- Up to 10 parameter sets can be downloaded / saved
- Communications between an AOP and MICROMASTER are realized using the USS protocol. An AOP can be connected to the BOP link (RS 232) as well as to the COM link interface (RS 485) of the drive inverter.
- Multi-point capable coupling to control (open-loop) and visualize up to 31 MICROMASTER drive inverters. The USS bus must, in this case, be configured and parameterized via the drive inverter terminals of the COM link interface.

Please refer to Sections 3.2.3, 3.2.4 and the AOP Manual for additional details.

---

#### NOTE

- Contrary to the BOP, for the AOP, the communications parameters of the particular interface must be taken into account.
  - When inserting / connecting to the drive inverter, the AOP automatically changes the parameter P2012 (USS-PZD length) to 4 corresponding to the interface.
 

COM link:	P2012[0]
BOP link:	P2012[1]
  - For DriveMonitor, the default value for the USS-PZD length is set to 2. This results in a conflict if the AOP and the DriveMonitor are operated, alternating, at the same interface.  
Remedy: Increase the USS-PZD length to 4.
-

### 3.2.3 Keys and their functions on the operator panel (BOP / AOP)












Operator panel/key	Function	Effects
	Status display	The LCD indicates the settings which the drive inverter is presently using.
	Start motor	The drive inverter is started by pressing the key. This key is de-activated in the default setting. Parameter P0700 or P0719 should be changed as follows to activate the key: BOP: P0700 = 1 or P0719 = 10 ... 16 AOP: P0700 = 4 or P0719 = 40 ... 46 on the BOP link P0700 = 5 or P0719 = 50 ... 56 on the COM link
	Stop motor	OFF1 When this key is pressed, the motor comes to a standstill within the selected ramp-down time. It is de-activated in the default setting; to activate → refer to the "Start motor" key. OFF2 The motor coasts down to a standstill by pressing the key twice (or pressing once for a longer period of time). This function is always activated.
	Direction reversal	To reverse the direction of rotation of the motor, press this key. The opposing direction is displayed using the minus character (-) or by the flashing decimal point. In the default setting this function is de-activated; to activate it → refer to the "Start motor" key.
	Jog motor	In the "Ready to power-on" state, when this key is pressed, the motor starts and rotates with the pre-set jog frequency. The motor stops when the key is released. When the motor is rotating, this key has no effect.
	Functions	This key can be used to display additional information. If you press the key during operation, independent of the particular parameter, for two seconds, then the following data is displayed: 1. Voltage of the DC current link (designated by d – units V). 2. Output current (A) 3. Output frequency (Hz) 4. Output voltage (designated by o – units V). 5. The value, selected in P0005 (if P0005 is configured so that one of the above pieces of data is displayed (1 to 4), then the associated value is not re-displayed). The displays mentioned above are run-through one after the other by pressing again. <b>Step function</b> Starting from any parameter (rXXXX or PXXXX), if the key Fn is briefly pressed, then a jump is immediately made to r0000. You can then, when required, change an additional parameter. After returning to r0000, when key Fn is pressed, then the system returns to the starting point. <b>Acknowledgement</b> If alarm and fault messages are present, then these can be acknowledged by pressing key Fn.
	Parameter access	Parameters can be accessed by pressing this key.
	Increase value	When this key is pressed, the displayed value is increased.
	Reduce value	When this key is pressed, the displayed value is decreased.
	AOP menu	Calls the AOP menu prompting (this is only available for AOP).

Fig. 3-15 Operator panel keys

### 3.2.4 Changing parameters using the operator panel

The way that parameter P0719 can be changed will now be described; please use this description as a basis when setting all of the other parameters using the BOP.

#### Changing P0004 – parameter filter function

Step	Result on the display
1 Press  in order to access the parameter	
2 Press  until P0004 is displayed	
3 Press  in order to reach the parameter value level	
4 Press  or  in order to obtain the required value	
5 Press  to acknowledge the value and to save the value	
6 The user can only see the command parameters.	

#### Changing an indexed parameter P0719 – selecting the command/frequency setpoint













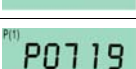



Step	Result on the display
1 Press  in order to access the parameter	
2 Press  until P0719 is displayed	
3 Press  in order to reach the parameter value	
4 Press  in order to display the currently set value	
5 Press  or  in order to obtain the required value	
6 Press  to acknowledge the value and to save the value	
7 Press  until r0000 is displayed	
8 Press  in order to return to the operating display (the display which the customer has defined)	

Fig. 3-16 Changing parameters using the BOP

#### NOTE

The BOP sometimes display **buSY** when changing parameter values. This means that the drive inverter is presently handling another higher-priority task.

### 3.3 Block diagram

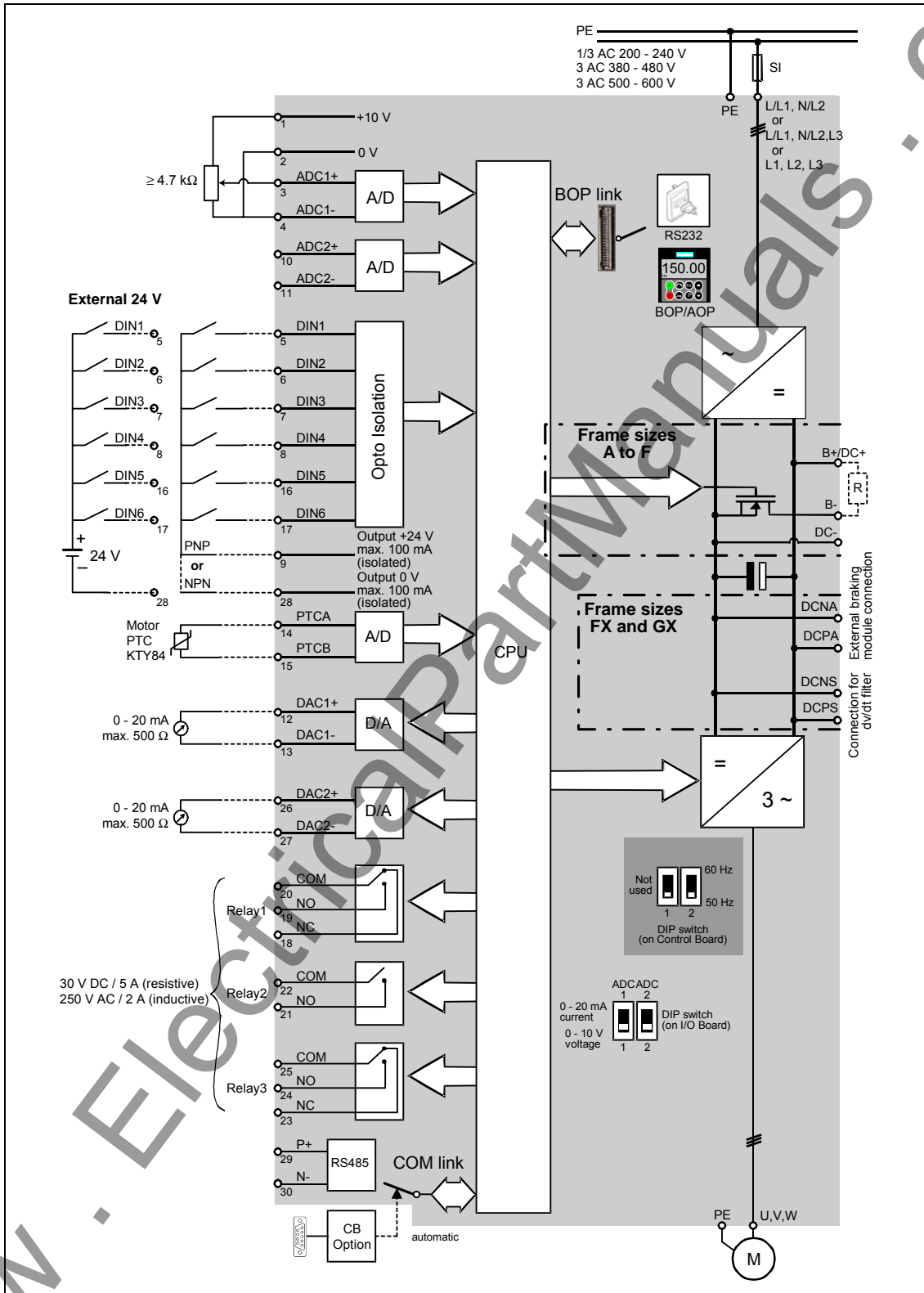


Fig. 3-17 MICROMASTER 440 – block diagram

### 3.4 Factory setting

The MICROMASTER drive unit is shipped from the plant with a Status Display Panel (SDP, refer to Fig. 3-18). The SDP has two LEDs on the front panel which display the operating state of the drive inverter (refer to Section 4.1).

When MICROMASTER is shipped from the plant with the SDP functioning, it can be operated without any additional parameterization. In this case, the drive inverter default settings (which depend on the drive inverter type / size) match the following data of a 4-pole motor:

- Rated motor power P0307
- Rated motor voltage P0304
- Rated motor current P0305
- Rated motor frequency P0310

(We recommend a Siemens standard motor.)

Further, the following conditions must be fulfilled:

- Control (ON/OFF command) via digital inputs (refer to Table 3-7)
- Setpoint input via analog input 1 P1000 = 2
- Induction motor P0300 = 1
- Self-cooled motor P0335 = 0
- Motor overload factor P0640 = 150 %
- Min. frequency P1080 = 0 Hz
- Max. frequency P1082 = 50 Hz
- Ramp-up time P1120 = 10 s
- Ramp-down time P1121 = 10 s
- Linear V/f characteristic P1300 = 0

Table 3-7 Pre-assignment of the digital inputs

Digital inputs	Terminals	Parameter	Function	Active
Command source	-	P0700 = 2	Terminal strip	Yes
Digital input 1	5	P0701 = 1	ON / OFF1	Yes
Digital input 2	6	P0702 = 12	Reversing	Yes
Digital input 3	7	P0703 = 9	Fault acknowledge	Yes
Digital input 4	8	P0704 = 15	Fixed setpoint (direct)	No
Digital input 5	16	P0705 = 15	Fixed setpoint (direct)	No
Digital input 6	17	P0706 = 15	Fixed setpoint (direct)	No
Digital input 7	Via ADC1	P0707 = 0	Digital input disabled	No
Digital input 8	Via ADC2	P0708 = 0	Digital input disabled	No



Fig. 3-18 Status Display Panel (SDP)

If the various prerequisites are fulfilled and the appropriate conditions present, then after the motor has been connected and the power connected, then the following is possible with the factory setting:

- The motor can be started and stopped (via DIN1 with external switch)
- The direction of rotation can be reversed (via DIN2 with external switch)
- Faults reset (via DIN3 with external switch)
- A frequency setpoint can be entered (via ADC1 with external potentiometer  
default setting of the ADC.  
Voltage input)
- The frequency actual value can be output (via D/A converter, D/A converter  
output: current output)

The potentiometer and the external switches can be connected through the drive inverter internal power supply, as shown in Fig. 3-19.

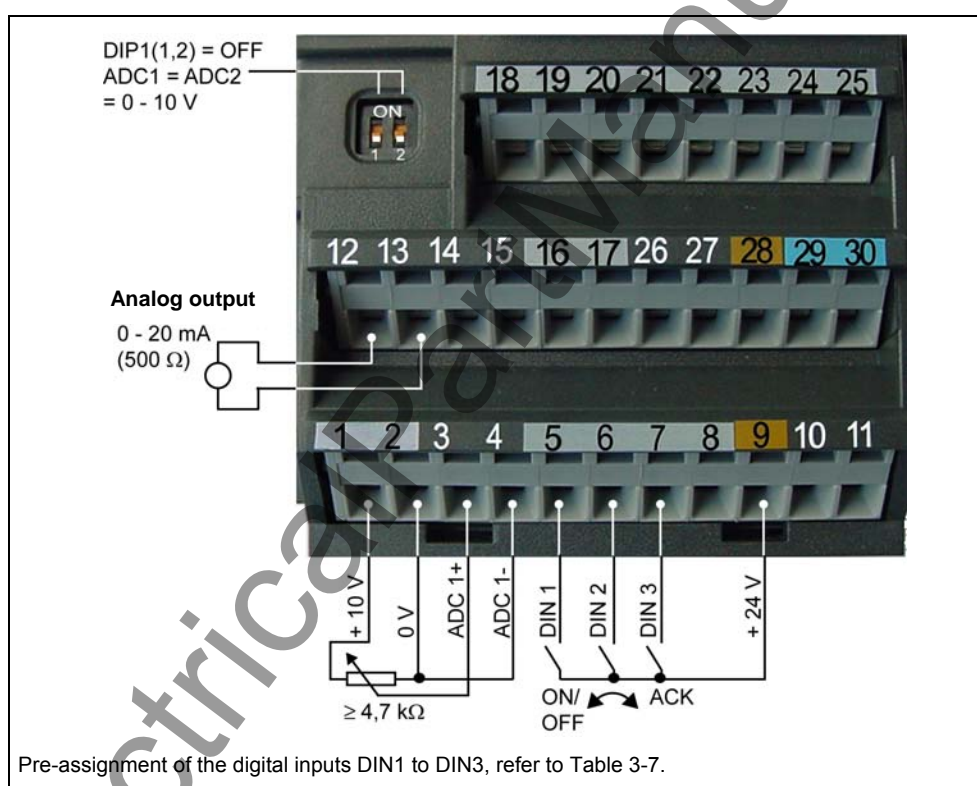


Fig. 3-19 Recommended wiring for the factory setting

If settings have to be made which go beyond the factory setting, then depending on the complexity of the application, when commissioning the drive system, the particular function description as well as the parameter list including function charts must be carefully taken into consideration.

### 3.5 Commissioning

A differentiation is made between the following scenarios when commissioning MICROMASTER:

- 50/60 Hz changeover
- Motor data identification
- Series commissioning
- Quick commissioning
- Calculating the motor / control data
- Commissioning the application

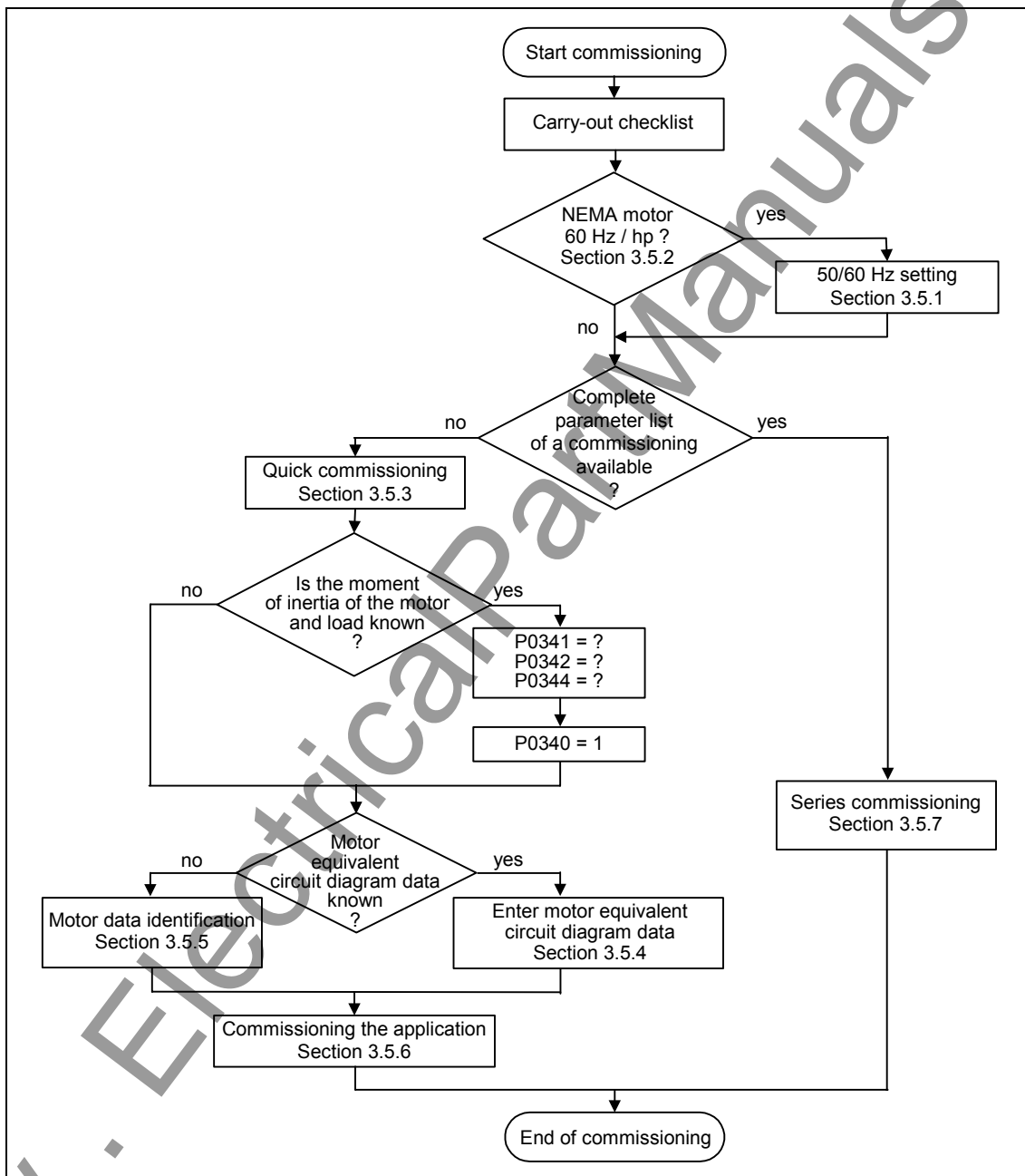


Fig. 3-20 Procedure when commissioning

When commissioning, initially, a quick or series commissioning should be carried-out. The actual application should only be commissioned if the drive inverter – motor combination provides a satisfactory result.

If the drive is to be commissioned from a defined state, then the drive inverter can be reset to the initial state when it left the plant. This is done as follows:

- Reset parameters to the factory setting

### Check list

The following check list should help you to commission MICROMASTER without any problems and to guarantee a high degree of availability:

- When handling the drive unit, carefully observe all of the ESD measures.
- All of the screws must have been tightened up to their specified torque.
- All connectors / option modules must have been correctly inserted and locked / screwed into place.
- The DC link pre-charging has been completed.
- All of the components are grounded/earthed at the points provided and all of the shields have been connected.
- MICROMASTER drive units have been designed for defined mechanical, climatic and electrical ambient conditions. It is not permissible that the specified limit values are exceeded in operation and when the drive units are being transported. The following must be especially carefully observed:
  - ◆ Line supply conditions
  - ◆ Pollutant stressing
  - ◆ Gases which can have a negative impact on the function
  - ◆ Ambient climatic conditions
  - ◆ Storage / transport
  - ◆ Shock stressing
  - ◆ Vibration stressing
  - ◆ Ambient temperature
  - ◆ Installation altitude

In addition to carrying-out all of the installation work, an important prerequisite for successful commissioning is that the drive inverter is not disconnected from the line supply while being parameterized. If a line supply failure interrupts commissioning, then inconsistencies can occur regarding the parameterization. In this case, it is important that the commissioning is re-started (possibly reset and establish the original factory settings (refer to Section 3.5.9)).

---

#### NOTE

When using output reactors, the pulse frequency may not be set higher than 4 kHz.

The following parameter setting is mandatory when using an output reactor:

P1800 = 4 kHz , P0290 = 0 or 1

---

### 3.5.1 50/60 Hz setting

The frequency setting made in the factory can be adapted to the North American market, without requiring any parameterization using an operator panel or PC tool using the DIP50/60 switch (refer to Fig. 3-21) under the I/O board (refer to the Appendix C when removing the I/O board).

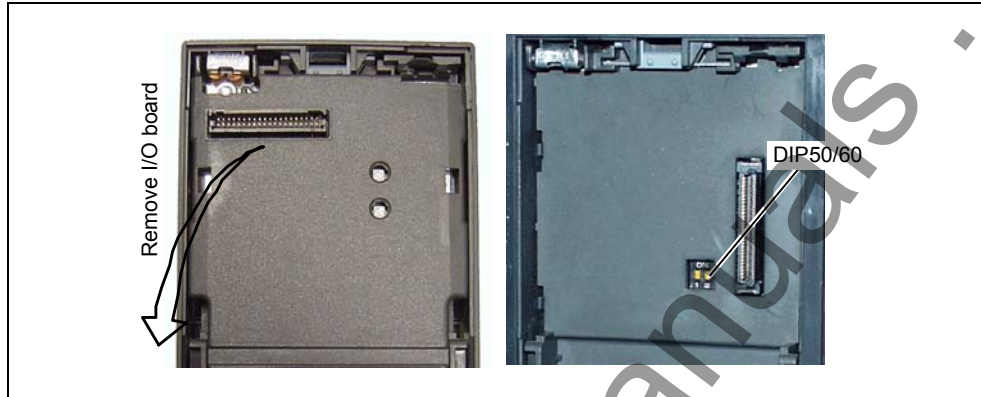


Fig. 3-21 DIP switch to change-over between 50/60 Hz

The switch determines the value of parameter P0100 corresponding to the following diagram (refer to Fig. 3-22). Besides P0100 = 2, after the power supply voltage has been switched-in, the DIP50/60 switch determines the 50/60 Hz setting (value of parameter P0100).

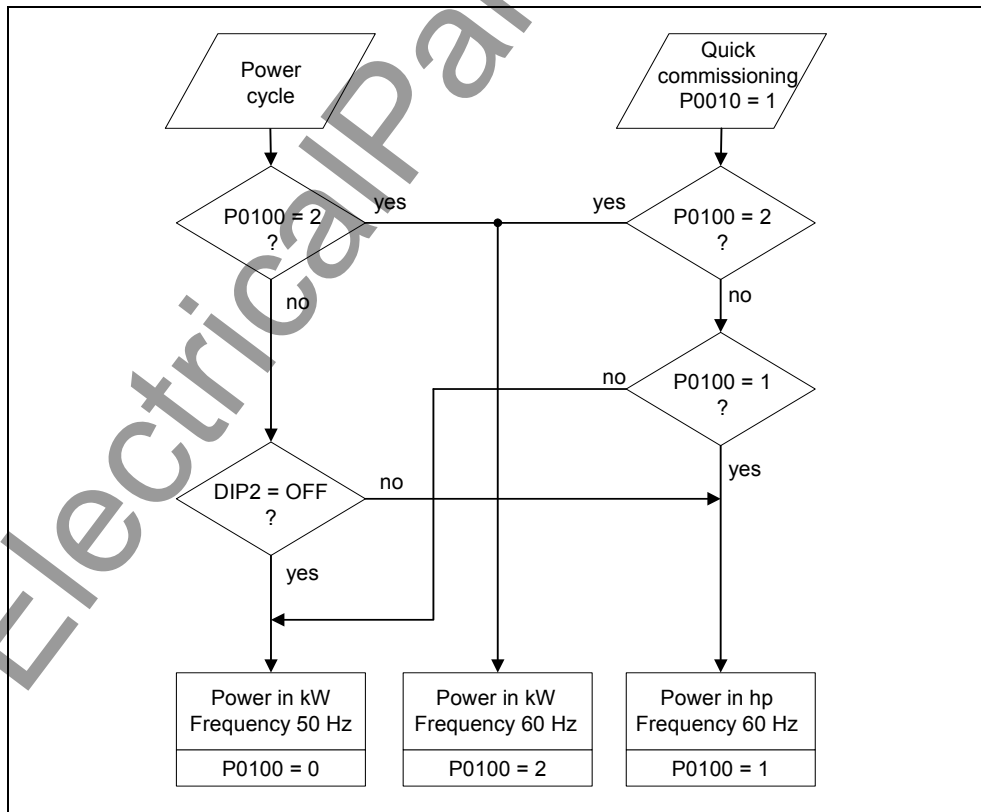


Fig. 3-22 Mode of operation of the DIP50/60 switch in conjunction with P0100

By changing the setting of DIP50/60 switch, after the drive inverter has been powered-down/power-up, the parameters for the rated motor frequency P0310, max. frequency P1082 and reference frequency P2000 are automatically pre-set. In addition, the rated motor parameters as well as all of the other parameters which depend on the rated motor parameters, are reset. The units of the power parameters are, depending on P0100, are either interpreted as kW value or hp value.

**NOTE**

Switch DIP2(1) (refer to Fig. 3-21) under the I/O board has no function.

**3.5.2 Motor circuit**

In order to ensure a straightforward, successful commissioning, it is important that the circuit connection in the motor terminal box (refer to Fig. 3-23) matches the rated motor voltage entered in P0304 or the rated motor current P0305.

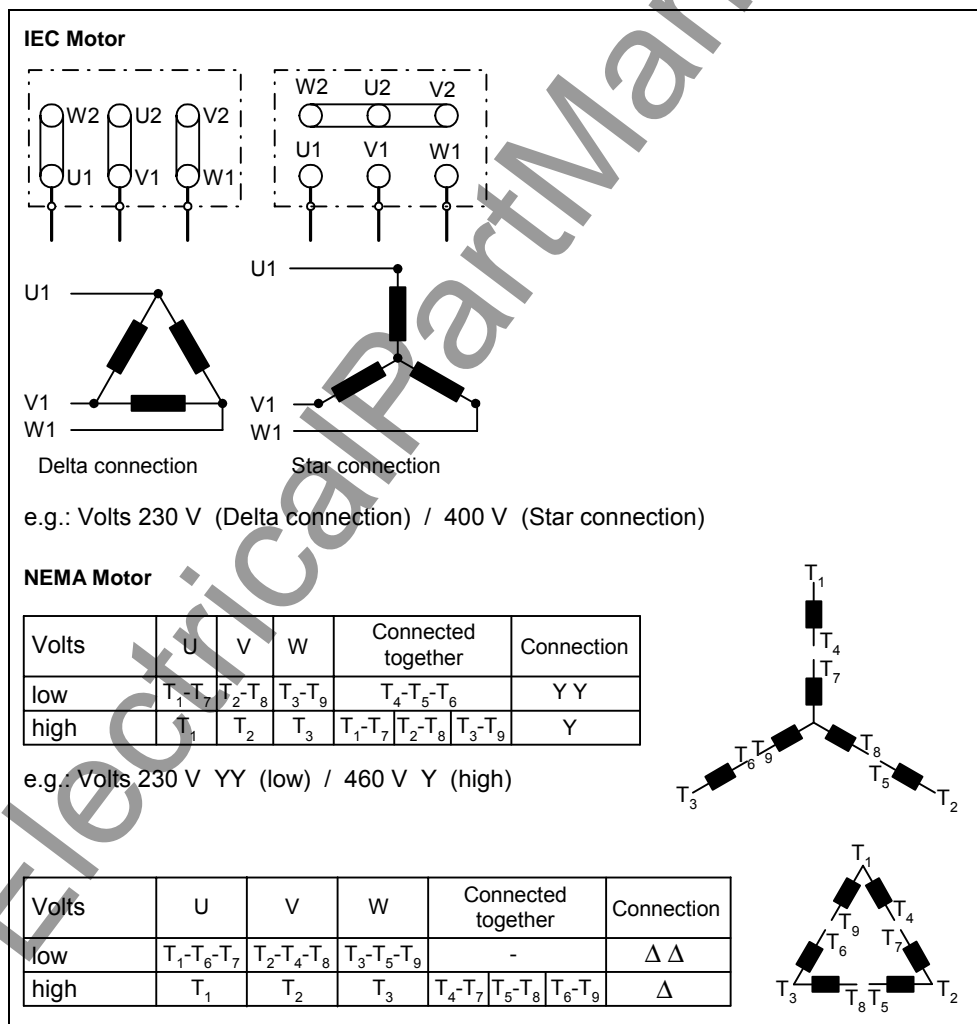


Fig. 3-23 Motor terminal box

The following must be noted when entering the rating plate data or the ESB data:

- The outer conductor voltage/phase-to-phase voltage (voltage  $U_{12}$  between outer conductors L1, L2) and the outer conductor current (phase current)  $I_1$  are always specified on the rating plate.
- The rated motor voltage P0304 and the rated motor current P0305 must always be entered according to the motor circuit configuration (either delta/star circuit configuration).
- If rated motor data that are available (P0304, P0305) are not consistent with the motor circuit configuration, then an appropriate conversion should be made which is then entered.
- If equivalent circuit diagram data (P0350, P0354, P0356, P0358, P0360) is available, then these should be entered according to the motor circuit configuration. If there is no consistency between the motor circuit configuration and equivalent circuit diagram data, then the equivalent circuit diagram data should be converted and entered corresponding to the data on the rating plate (P0304, P0305).

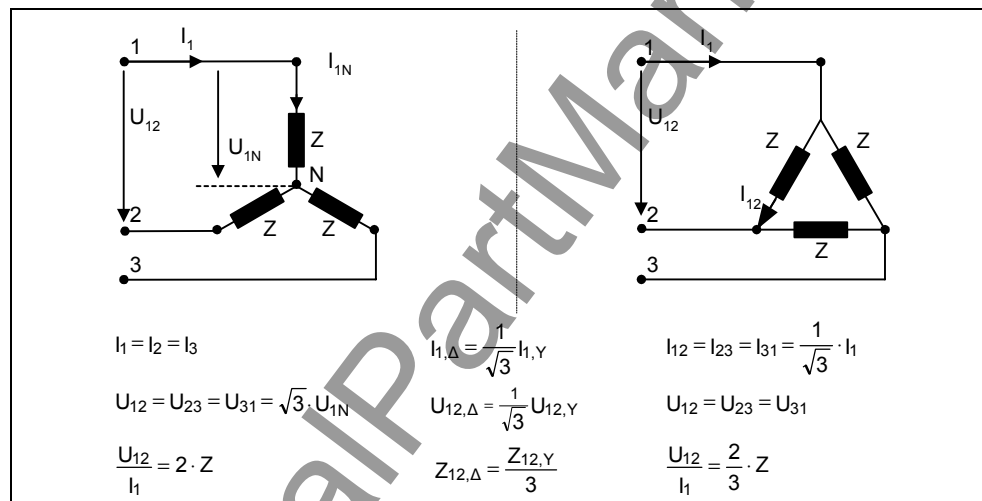


Fig. 3-24 Star / delta circuit configurations

#### NOTE

The precise equivalent circuit diagram data are of extreme important regarding the stability of the closed-loop vector control and for the voltage boost applied to the V/f characteristic. Equivalent circuit diagram data can only be estimated from the rating plate data; this is the reason that equivalent circuit diagram data is either determined

- using the motor data identification (refer to Chapter 0), or
- is entered from a motor data sheet that may be available (refer to Chapter 0).

#### NOTE

The MICROMASTER series of drive units is not available for 3-ph. 690 V AC.

### 87 Hz characteristic

When a motor with a delta circuit configuration (e. g.  $V_{N\Delta, motor} = 230 \text{ V}$ ) is fed from a frequency inverter, where the rated voltage corresponds to the star circuit configuration (e.g. 400 V frequency inverter), then it is important to proceed as follows and observe the following:

- The motor must have the appropriate voltage strength.
- Above the rated motor frequency, the iron losses in the motor increase over-proportionally. This is the reason that above this frequency, the thermal motor torque should be reduced.
- For the quick commissioning, the rating plate data for the delta circuit configuration should be entered or the rating plate must be appropriately converted.
- The drive inverter must be designed for the higher current (delta circuit configuration).
- The 87 Hz characteristic is independent of the control type and can therefore be used both for V/f control as well as for closed-loop vector control.
- When using the 87 Hz characteristic, the mechanical motor limits must be taken into account (refer to Catalog M11).

For the 87 Hz characteristic, the ratio between the voltage and frequency (V/f characteristic) remain constant. This is the reason that the following relationships apply:

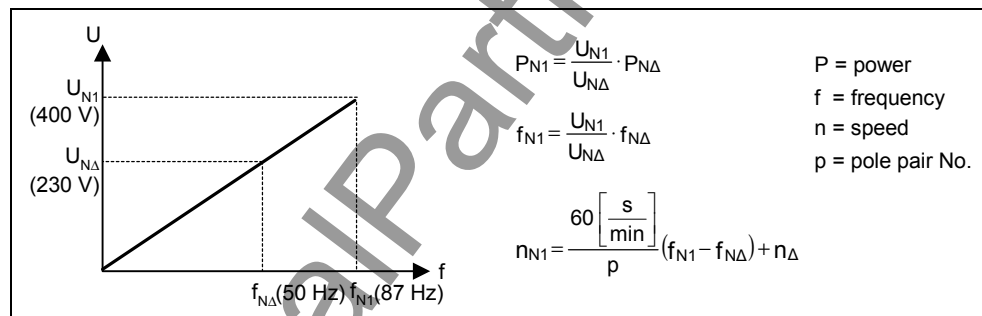


Fig. 3-25 V/f characteristic

Table 3-8 Example 1LA7060-4AB10

		Delta circuit configuration	87 Hz characteristic	Star circuit configuration
P0304	Rated motor voltage	230 V	400 V	400 V
P0305	Rated motor current	0.73 A	0.73 A	0.42 A
P0307	Rated motor power	120 W	207 W	120 W
P0308	Cos $\varphi$	0.75	0.75	0.75
P0310	Rated motor frequency	50 Hz	87 Hz	50 Hz
P0311	Rated motor speed	1350 RPM	2460 RPM	1350 RPM
P0314	Motor pole pairs	2	2	2

Contrary to the BOP, AOP operator panels or the commissioning program Drive-Monitor, the STARTER commissioning (start-up) program offers a mask-orientated quick commissioning, which is especially advantageous for users who are using MICROMASTER for the first time. On the other hand, BOP, AOP and DriveMonitor offer, in conjunction with the drive inverter, parameter-orientated quick commissioning where the user is navigated through the menu tree mentioned.

### 3.5.3 Quick commissioning

If there is still no appropriate parameter set for the drive, then a quick commissioning must be carried-out for the closed-loop Vector control and for the V/f control including a motor data identification routine. The following operator units can be used to carry-out quick commissioning:

- BOP (option)
- AOP (option)
- PC Tools (with commissioning program STARTER, DriveMonitor)

When the quick commissioning is carried-out, the motor – drive inverter is basically commissioned; the following data must be obtained before quick commissioning is started:

- Line supply frequency
- Motor rating plate data
- Command / setpoint sources
- Min. / max. frequency or ramp-up / ramp-down time
- Closed-loop control mode
- Motor data identification

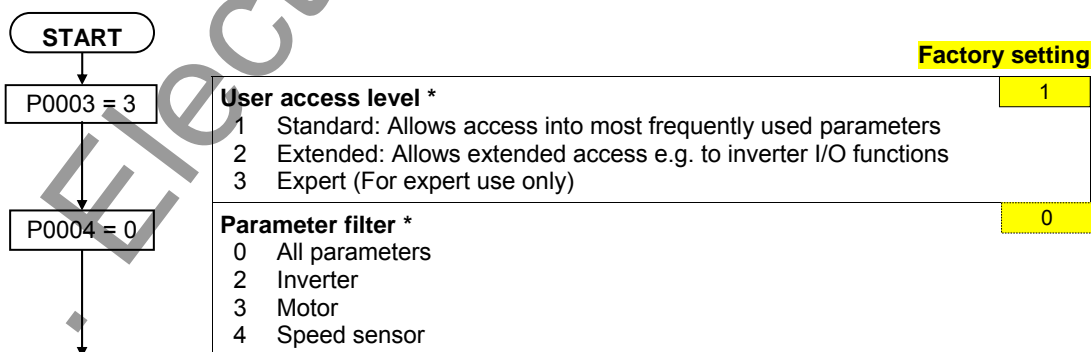
#### Parameterizing the drive with BOP or AOP

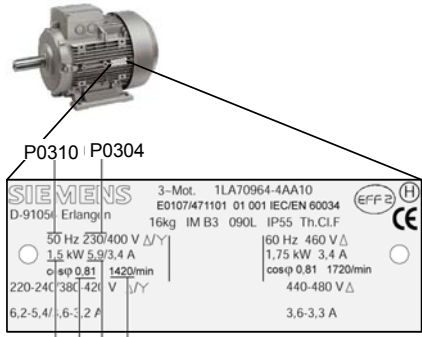
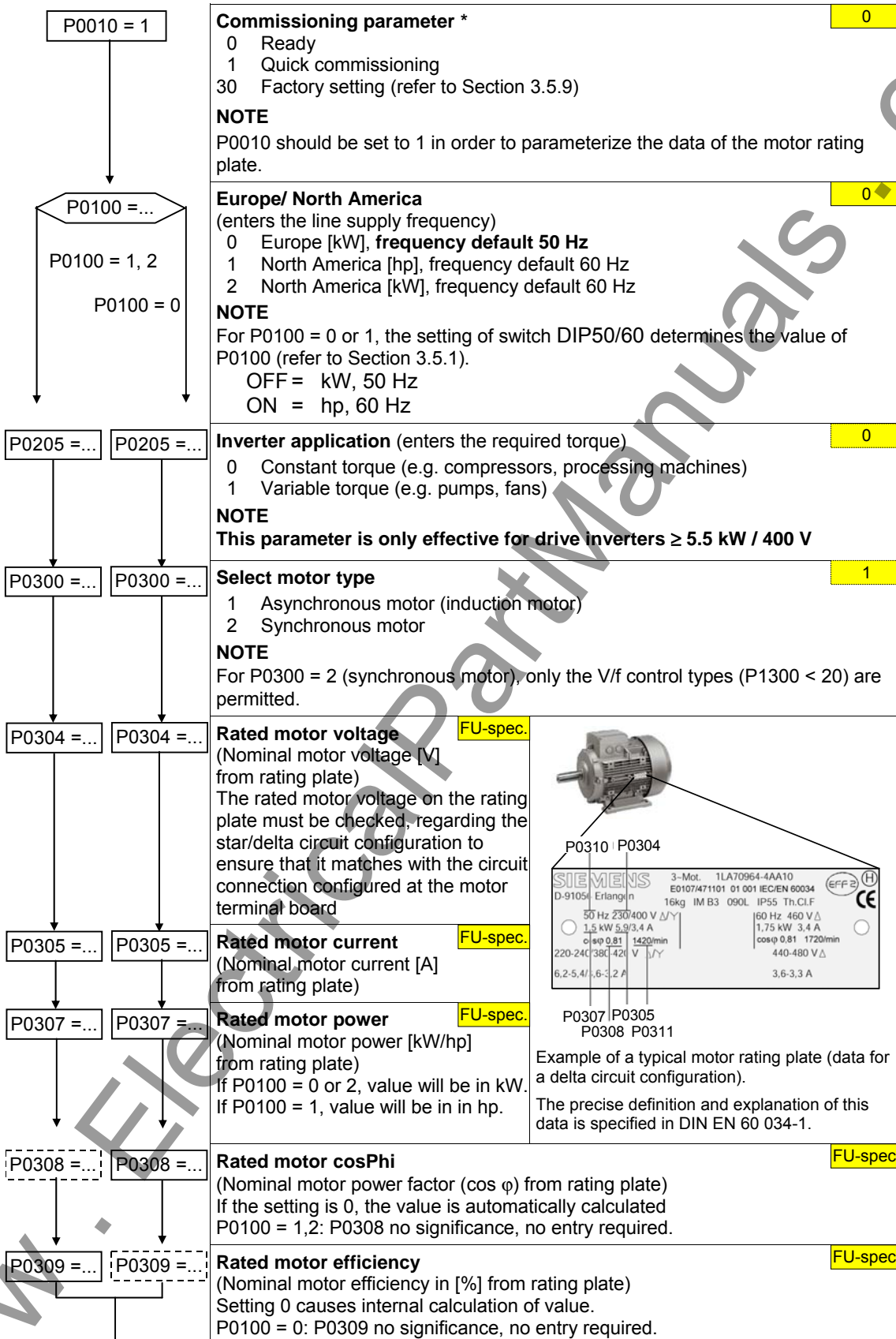
The frequency inverter is adapted to the motor using the quick commissioning function and important technological parameters are set. The quick commissioning shouldn't be carried-out if the rated motor data saved in the frequency inverter (4-pole 1LA Siemens motor, star circuit configuration  $\cong$  frequency inverter (FU)-specific) match the rating plate data.

Parameters, designated with a \* offer more setting possibilities than are actually listed here. Refer to the parameter list for additional setting possibilities.

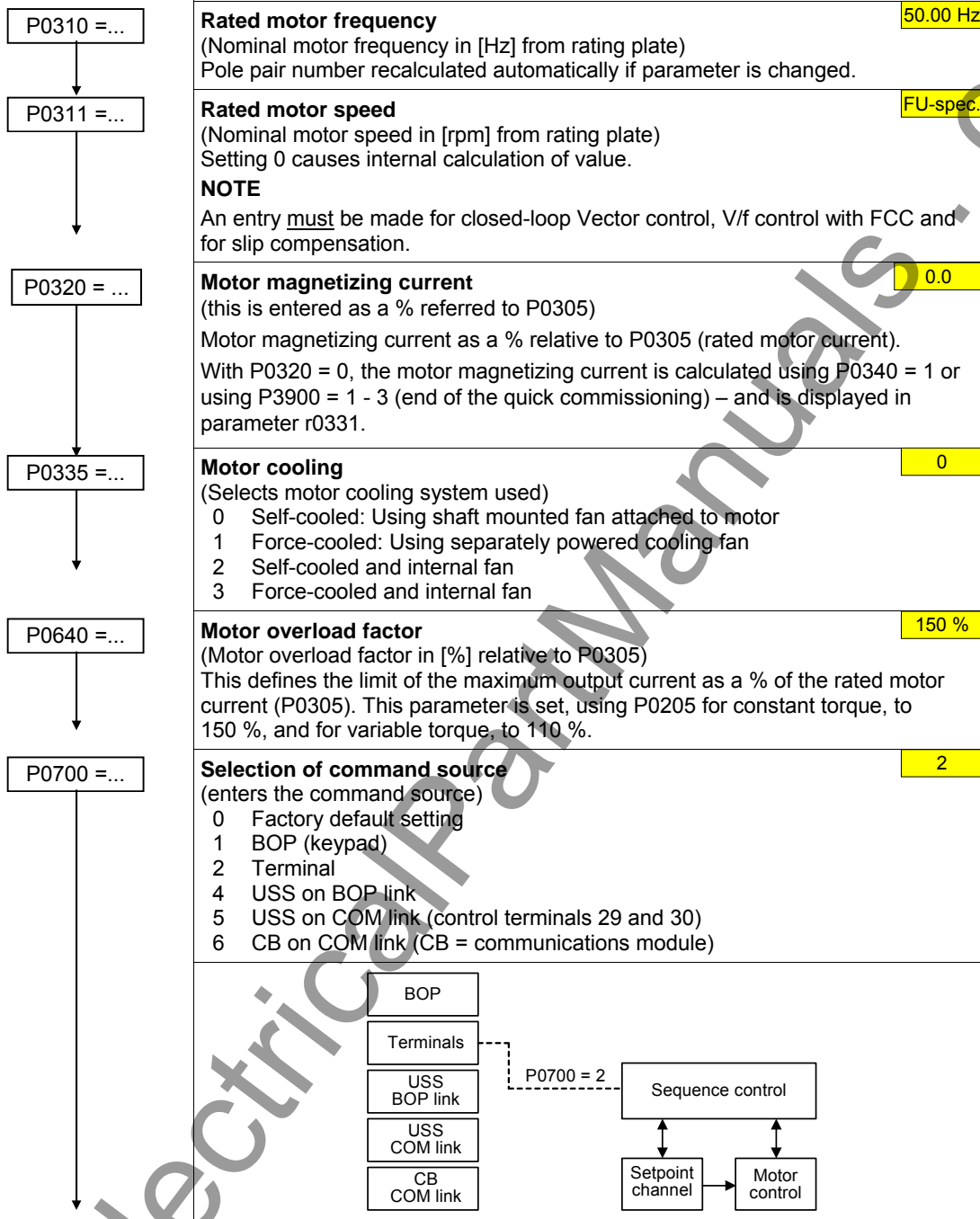
#### NOTE

- Parameter P0308 or P0309 can only be viewed on the BOP or AOP if P0003  $\geq$  2. Depending on the setting of parameter P0100, either P0308 or P0309 is displayed.
- The value entered into P0307 and all of the other power data – depending on P0100 – are either interpreted as kW or hp value.





Example of a typical motor rating plate (data for a delta circuit configuration).  
The precise definition and explanation of this data is specified in DIN EN 60 034-1.



P1000 =...

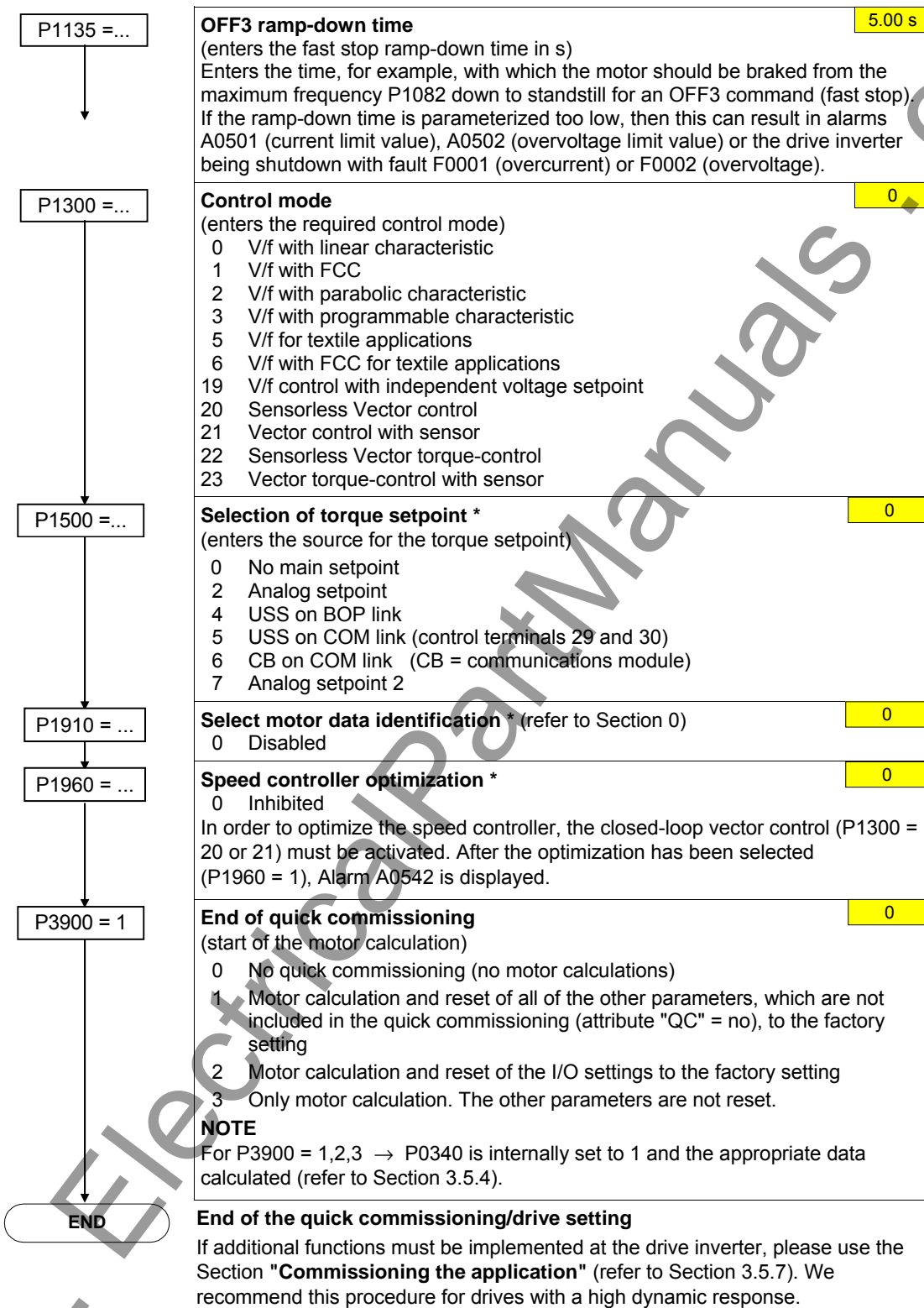
P1080 =...

P1082 =...

P1120 =...

P1121 =...

<p><b>Selection of frequency setpoint *</b> (enters the frequency setpoint source)</p> <ul style="list-style-type: none"> <li>1 MOP setpoint</li> <li>2 Analog setpoint</li> <li>3 Fixed frequency</li> <li>4 USS on BOP link</li> <li>5 USS on COM link (control terminals 29 and 30)</li> <li>6 CB on COM link (CB = communications module)</li> <li>10 No main setpoint + MOP setpoint</li> <li>11 MOP setpoint + MOP setpoint</li> <li>12 Analog setpoint + MOP setpoint</li> <li>...</li> <li>76 CB on COM link + Analog setpoint 2</li> <li>77 Analog setpoint 2 + Analog setpoint 2</li> </ul>	2
<p><b>Min. frequency</b> (enters the minimum motor frequency in Hz)</p> <p>Sets minimum motor frequency at which motor will run irrespective of frequency setpoint. The value set here is valid for both clockwise and anticlockwise rotation.</p>	0.00 Hz
<p><b>Max. frequency</b> (enters the maximum motor frequency in Hz)</p> <p>Sets maximum motor frequency at which motor will run irrespective of the frequency setpoint. The value set here is valid for both clockwise and anticlockwise rotation.</p>	50.00 Hz
<p><b>Ramp-up time</b> (enters the ramp-up time in s)</p> <p>Time taken for motor to accelerate from standstill up to maximum motor frequency (P1082) when no rounding is used. If a ramp-up time is parameterized which is too low, then this can result in alarm A0501 (current limit value) or the drive inverter being shutdown with fault F0001 (overcurrent).</p>	10.00 s
<p><b>Ramp-down time</b> (enters the deceleration time in s)</p> <p>Time taken for motor to decelerate from maximum motor frequency (P1082) down to standstill when no rounding is used. If the ramp-down time is parameterized too low, then this can result in alarms A0501 (current limit value), A0502 (overvoltage limit value) or the drive inverter being powered-down with fault F0001 (overcurrent) or F0002 (overvoltage).</p>	10.00 s



**WARNING**

The motor data identification routine (refer to Section 0) may not be used for loads which are potentially hazardous (e.g. suspended loads for crane applications). Before the motor data identification run is started, the potentially hazardous load must be carefully secured (e.g. by lowering the load to the floor or by clamping the load using the motor holding brake).

### 3.5.4 Calculating the motor / control data

The calculation of the internal motor / control data is initiated using parameter P0340 or indirectly using parameter P3900 (refer to Section 3.5.3) or P1910 (refer to Section 0). The functionality of parameter P0340 can, for example, be used if the equivalent circuit diagram data (refer to Fig. 3-26) or the moment of inertia is known. Possible settings for parameter P0340 are described in Table 3-9. Table 3-10 lists which parameters are calculated for the different settings.

Table 3-9 Possible settings for parameter P0340

Parameter	Description
P0340 = 0	No calculation is made
P0340 = 1	Starting from the rating plate parameters (P0300 - P0335) the motor equivalent circuit diagram parameters (P0350 - P0369) and the motor weight / moment of inertia (P0344, P0341) are determined. The V/f- / vector control parameters and reference quantities are then pre-assigned (this includes all calculations from P0340 = 2,3,4).
P0340 = 2	Starting from the rating plate parameters, the motor equivalent circuit diagram parameters (P0350 - P0369) are calculated (without any additional pre-assignments being made).
P0340 = 3	Starting from the motor equivalent circuit diagram parameters (P0350 - P0369) and motor weight / moment of inertia, moment of inertia ratio (P0344, P0341, P0342), the V/f- / vector control parameters are determined (contains all of the calculations from P0340 = 4).
P0340 = 4	Starting from the motor equivalent circuit diagram parameters (P0350 - P0369) and motor weight / moment of inertia, moment of inertia ratio (P0344, P0341, P0342), the vector control parameters are pre-assigned.

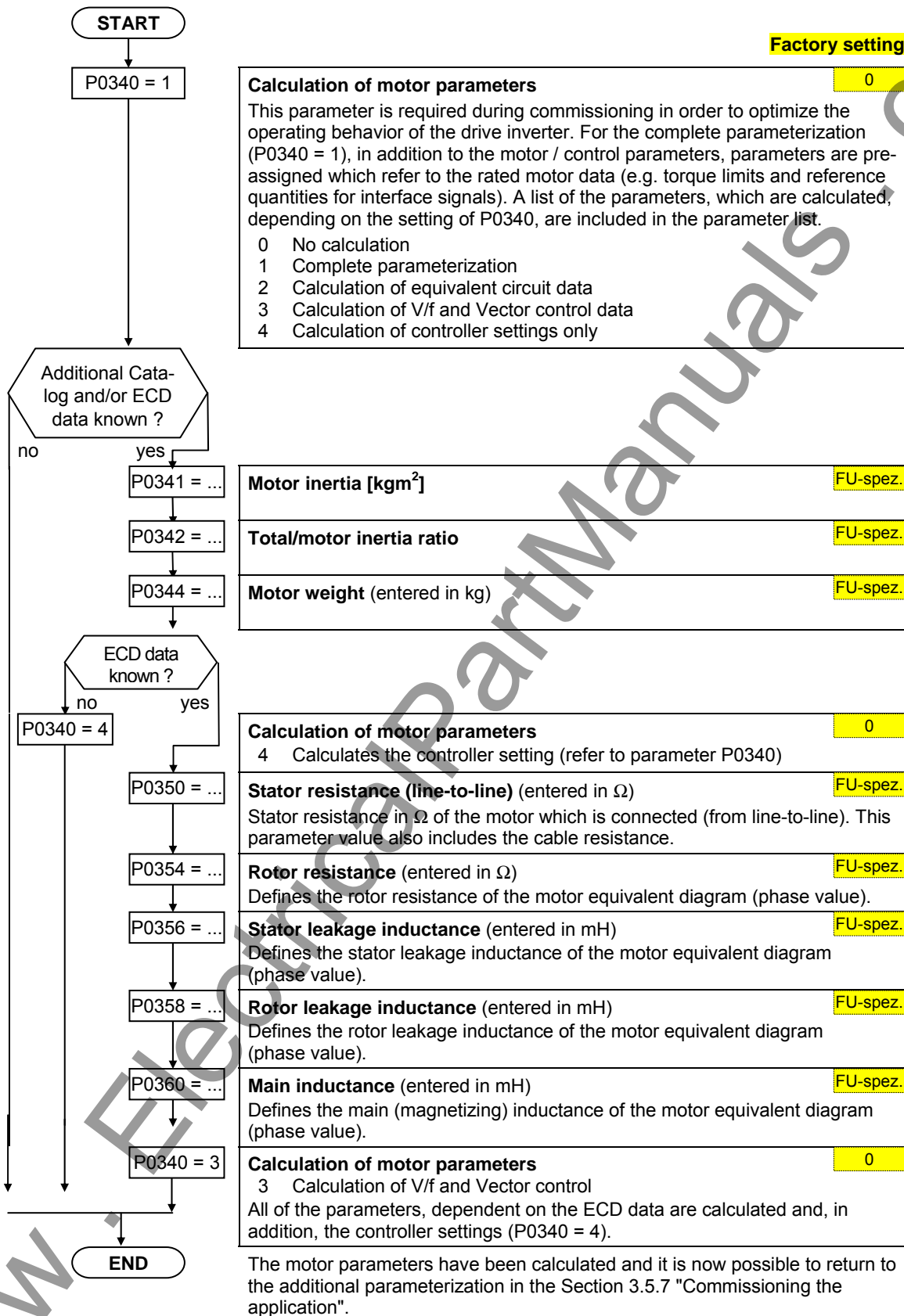
**NOTE**

- When exiting the quick commissioning with P3900 > 0 (refer to Section 3.5.3), internally P0340 is set to 1 (complete parameterization).
- For the motor data identification (refer to Section 0), after the measurement has been completed, internally P0340 is set to 3.
- Equivalent circuit diagram data always refer to the star circuit configuration equivalent circuit diagram. If data for the delta equivalent circuit diagram are available, then this should first be converted into the star equivalent circuit diagram data before being entered.
- If equivalent circuit diagram data (P0350, . . . , P0360) is available, then this must be entered according to the motor circuit configuration being used (a star circuit configuration requires star-type equivalent circuit diagram data). If there is no consistency between the motor circuit configuration and the equivalent circuit diagram data, then the equivalent circuit diagram data should be converted according to the motor circuit configuration actually being used (P0350<sub>Δ</sub> = P0350<sub>Y</sub>, etc.).

Table 3-10 Calculated parameters

	P0340 = 1	P0340 = 2	P0340 = 3	P0340 = 4
P0341[3] Motor inertia [kg*m <sup>2</sup> ]	x			
P0342[3] Total/motor inertia ratio	x			
P0344[3] Motor weight	x			
P0346[3] Magnetization time	x		x	
P0347[3] Demagnetization time	x		x	
P0350[3] Stator resistance (line-to-line)	x	x		
P0352[3] Cable resistance	x	x		
P0354[3] Rotor resistance	x	x		
P0356[3] Stator leakage inductance	x	x		
P0358[3] Rotor leakage inductance	x	x		
P0360[3] Main inductance	x	x		
P0362[3] Magnetizing curve flux 1	x	x		
P0363[3] Magnetizing curve flux 2	x	x		
P0364[3] Magnetizing curve flux 3	x	x		
P0365[3] Magnetizing curve flux 4	x	x		
P0366[3] Magnetizing curve imag 1	x	x		
P0367[3] Magnetizing curve imag 2	x	x		
P0368[3] Magnetizing curve imag 3	x	x		
P0369[3] Magnetizing curve imag 4	x	x		
P0625[3] Ambient motor temperature	x	x		
P1253[3] Vdc-controller output limitation	x		x	
P1316[3] Boost end frequency	x		x	
P1460[3] Gain speed controller	x		x	x
P1462[3] Integral time speed controller	x		x	x
P1470[3] Gain speed controller (SLVC)	x		x	x
P1472[3] Integral time n-ctrl. (SLVC)	x		x	x
P1520[3] CO: Upper torque limit	x			
P1521[3] CO: Lower torque limit	x			
P1530[3] Motoring power limitation	x			
P1531[3] Regenerative power limitation	x			
P1715[3] Gain current controller	x		x	x
P1717[3] Integral time current controller	x		x	x
P1764[3] Kp of n-adaption (SLVC)	x		x	x
P1767[3] Tn of n-adaption (SLVC)	x		x	x
P2000[3] Reference frequency	x			
P2002[3] Reference current	x			
P2003[3] Reference torque	x			
P2174[3] Torque threshold M_thresh	x			
P2185[3] Upper torque threshold 1	x			
P2186[3] Lower torque threshold 1	x			
P2187[3] Upper torque threshold 2	x			
P2188[3] Lower torque threshold 2	x			
P2189[3] Upper torque threshold 3	x			
P2190[3] Lower torque threshold 3	x			

When calculating the motor / control data using P0340, there are different scenarios (refer to the following flowchart), which can be called-up as a function of the known data.



**Factory setting**

**Calculation of motor parameters** 0

This parameter is required during commissioning in order to optimize the operating behavior of the drive inverter. For the complete parameterization (P0340 = 1), in addition to the motor / control parameters, parameters are pre-assigned which refer to the rated motor data (e.g. torque limits and reference quantities for interface signals). A list of the parameters, which are calculated, depending on the setting of P0340, are included in the parameter list.

- 0 No calculation
- 1 Complete parameterization
- 2 Calculation of equivalent circuit data
- 3 Calculation of V/f and Vector control data
- 4 Calculation of controller settings only

<b>P0341 = ...</b>	<b>Motor inertia [kgm<sup>2</sup>]</b>	<b>FU-spez.</b>
<b>P0342 = ...</b>	<b>Total/motor inertia ratio</b>	<b>FU-spez.</b>
<b>P0344 = ...</b>	<b>Motor weight (entered in kg)</b>	<b>FU-spez.</b>

<b>Calculation of motor parameters</b>	<b>0</b>
4 Calculates the controller setting (refer to parameter P0340)	
<b>P0350 = ...</b>	<b>Stator resistance (line-to-line) (entered in Ω)</b> <b>FU-spez.</b>
Stator resistance in Ω of the motor which is connected (from line-to-line). This parameter value also includes the cable resistance.	
<b>P0354 = ...</b>	<b>Rotor resistance (entered in Ω)</b> <b>FU-spez.</b>
Defines the rotor resistance of the motor equivalent diagram (phase value).	
<b>P0356 = ...</b>	<b>Stator leakage inductance (entered in mH)</b> <b>FU-spez.</b>
Defines the stator leakage inductance of the motor equivalent diagram (phase value).	
<b>P0358 = ...</b>	<b>Rotor leakage inductance (entered in mH)</b> <b>FU-spez.</b>
Defines the rotor leakage inductance of the motor equivalent diagram (phase value).	
<b>P0360 = ...</b>	<b>Main inductance (entered in mH)</b> <b>FU-spez.</b>
Defines the main (magnetizing) inductance of the motor equivalent diagram (phase value).	

**Calculation of motor parameters** 0

3 Calculation of V/f and Vector control

All of the parameters, dependent on the ECD data are calculated and, in addition, the controller settings (P0340 = 4).

The motor parameters have been calculated and it is now possible to return to the additional parameterization in the Section 3.5.7 "Commissioning the application".

### 3.5.5 Motor data identification

MICROMASTER has a measuring technique which is used to determine the motor parameters:

- Equivalent circuit data (ECD, refer to Fig. 3-26) → P1910 = 1
- Magnetizing characteristic (refer to Fig. 3-27) → P1910 = 3

For control-related reasons, we absolutely recommend that the motor data identification is carried-out as, starting from the rating plate data, it is only possible to estimate the equivalent circuit data, the motor cable resistance, the IGBT let-through voltage and the compensation of IGBT interlocking times. For example, the stator resistance is extremely important for the stability of the closed-loop Vector control and for the voltage boost for the V/f characteristic. The motor data identification routine should be executed, especially if long feeder cables or if third-party motors are being used.

If the motor data identification routine is being started for the first time, then the following data (refer to Fig. 3-26) is determined, starting from the rating plate data (rated [nominal] data) with P1910 = 1:

- Equivalent circuit data
- Motor cable resistance
- IGBT on-state voltage and compensation of IGBT gating dead times

The rating plate data represent the initialization values for the identification. This is the reason that it is necessary to have correct and consistent input of the rating plate data when determining the data specified above (refer to Section 3.5.8).

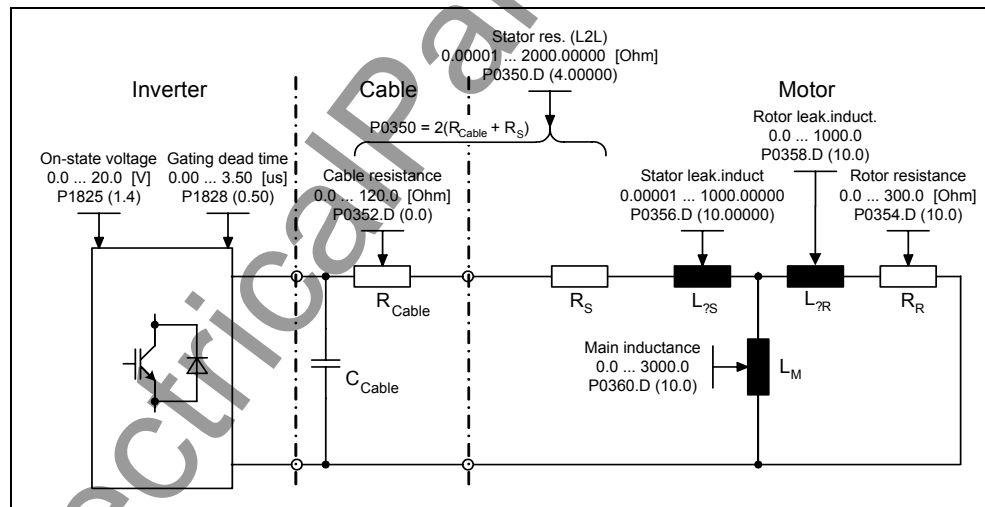


Fig. 3-26 Equivalent circuit diagram (ECD)

In addition to the equivalent circuit data, the motor magnetizing characteristic (refer to Fig. 3-26) can be determined using the motor data identification (P1910 = 3). If the motor-drive inverter combination is operated in the field-weakening range, then this characteristic should be determined, especially when Vector control is being used. As a result of this magnetizing characteristic, MICROMASTER can, in the field-weakening range, more precisely calculate the current which is generating the field and in turn achieve a higher torque accuracy.

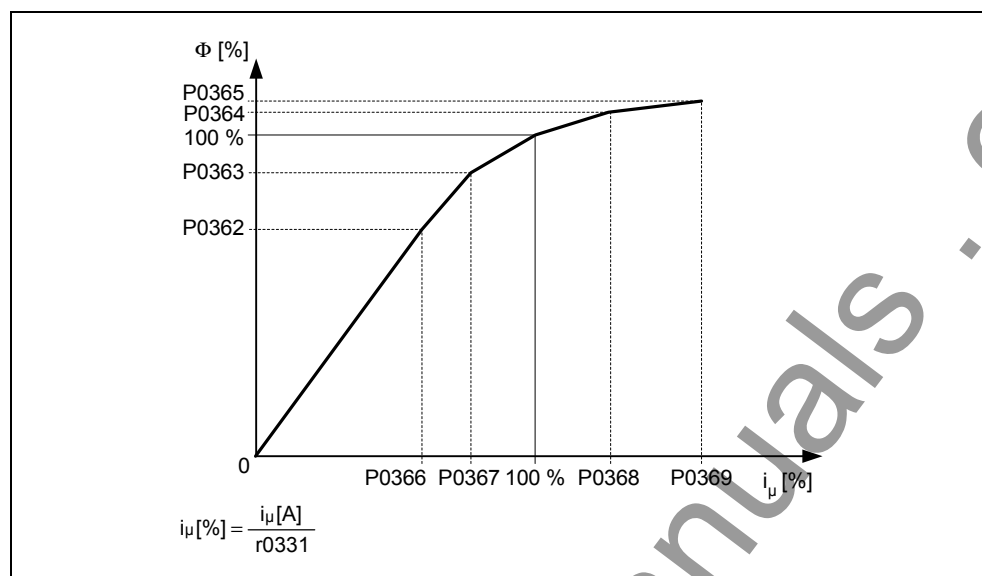


Fig. 3-27 Magnetizing characteristic

After selecting the motor data identification using parameter P1910, alarm A0541 is immediately generated. The motor identification routine is started by the ON command and different excitation signals are impressed in the motor (DC and AC voltages). This measurement is carried-out with the motor at a standstill and it takes, including the data calculation per selection (P1910 = 1.3) between 20 s ... 4 min. The identification time depends on the motor and increases with its size (this takes approx. 4 min for a 200 kW motor).

The motor data identification routine must be carried-out with the motor in the cold condition so that the motor resistance values saved can be assigned to the parameter of the ambient temperature P0625. Only then is correct temperature adaptation of the resistances possible during operation.

The motor data identification routine operates with the results of the "Complete parameterization" P0340 = 1 or the motor equivalent diagram data which was last saved. The results become increasingly better the more times that the identification routine is executed (up to 3 times).



#### WARNING

- It is not permissible to carry-out the motor identification routine for loads which are potentially hazardous (e.g. suspended loads for crane applications). Before starting the motor data identification routine, the potentially hazardous load must be secured (e.g. by lowering the load to the floor or clamping the load using the motor holding brake).
- When starting the motor data identification routine, the rotor can move into a preferred position. This is more significant for larger motors.

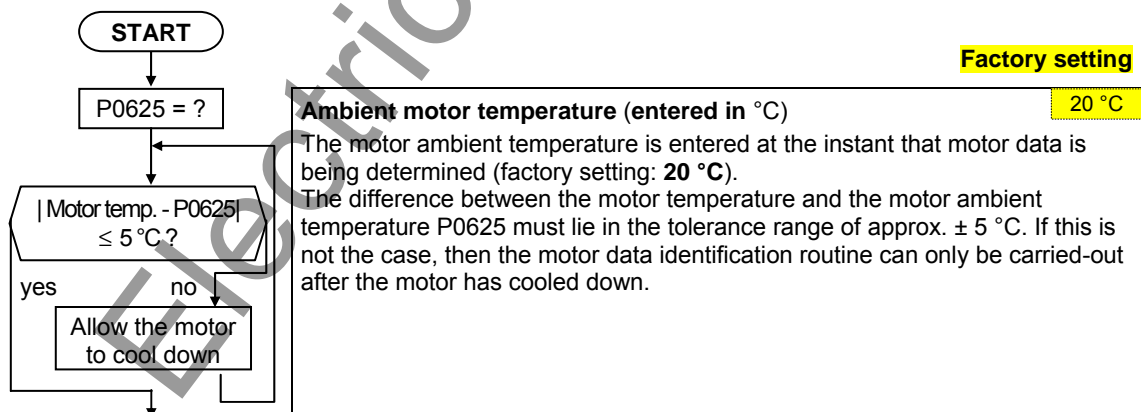
**NOTE**

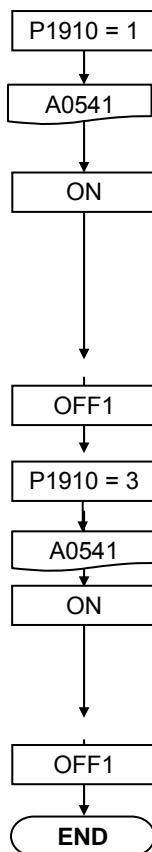
- The equivalent circuit data (P0350, P0354, P0356, P0358, P0360), with the exception of parameter P0350, should be entered as phase values. In this case, parameter P0350 (line-to-line value) corresponds to twice the phase value.
- Equivalent circuit diagram data always refer to the star circuit configuration equivalent circuit diagram data. If data for the delta equivalent circuit diagram is available, then this data must be converted into the star equivalent circuit diagram data before being entered (refer to Section 0).
- The motor cable resistance P0352 is defined as phase value
- During the motor identification routine, the stator resistance and the motor cable resistance are determined and entered into parameter P0350. If a correction is made in parameter P0352, then MICROMASTER defines the motor cable resistance using the following relationship:  $P0352 = 0.2 * P0350$ .
- If the motor cable resistance is known, then the value can be entered into parameter P0352 after the motor data identification. The stator resistance is appropriately reduced as a result of this entry and is therefore more precisely adapted to the actual application.
- It is not necessary to lock the motor rotor for the motor data identification routine. However, if it is possible to lock the motor rotor during the identification routine (e.g. by closing the motor holding brake), then this should be used to determine the equivalent circuit diagram data.
- The following formula can be applied to check the correctness of the motor rating plate data:

$$P_N = \sqrt{3} * V_{NY} * I_{NY} * \cos\phi * \eta \approx \sqrt{3} * V_{N\Delta} * I_{N\Delta} * \cos\phi * \eta$$

with	$P_N$	rated motor power
	$V_{NY}, V_{N\Delta}$	rated motor voltage (star / delta)
	$I_{NY}, I_{N\Delta}$	rated motor current (star / delta)
	$\cos\phi$	power factor
	$\eta$	efficiency

**Motor data identification routine**





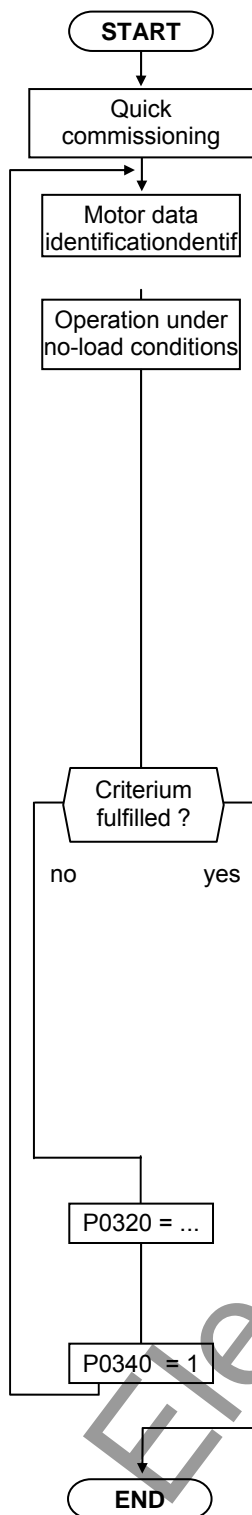
0	<p><b>Select motor data identification with P1910 = 1</b></p> <p>p1910 = 1: Identifies the motor parameter with parameter change. These are accepted and applied to the controller.</p> <p>When p1910 = 1 is selected, Alarm A0541 (motor data identification active) is output, and internally p0340 is set to 3.</p>
	<p><b>Starts the motor data identification run with p1910 = 1</b></p> <p>The measuring operation is initiated with the continuous (steady-state) ON command. The motor aligns itself and current flows through it. Diagnostics is possible using r0069 (CO: Phase current).</p> <p>After the motor data identification routine has been completed, p1910 is reset (p1910 = 0, motor data identification routine inhibited) and Alarm A0541 is cleared (deleted).</p>
	<p>In order to set the frequency converter into a defined state, an OFF1 command must be issued before the next step.</p>
0	<p><b>Select motor data identification with P1910 = 3</b></p> <p>p1910 = 3: Identifies the saturation characteristic with parameter change. When p1910 = 3 is selected, Alarm A0541 (motor data identification active) is output and internally, p0340 is set to 2.</p>
	<p><b>Starts the motor data identification run with P1910 = 3</b></p> <p>The measuring operation must be started with a continuous ON command. After the motor identification routine has been completed, p1910 is reset (p1910 = 0, motor data identification routine inhibited) and Alarm A0541 is cleared (deleted).</p>
	<p>In order to set the frequency converter into a defined state, an OFF1 command must be issued before the next step.</p>

If problems occur during the identification run, e.g. the current controller oscillates, then the rating plate data should be re-checked and an approximately correct magnetizing current P0320 entered. The motor data identification routine should then be re-started by calling P0340 = 1 (refer to Section 3.5.4).

### 3.5.6 Magnetizing current

- The value of the magnetizing current **r0331/P0320** has a significant influence on the closed-loop control. This cannot be measured at standstill. This means that the value is estimated for standard **4-pole 1LA7 SIEMENS standard** using the automatic parameterization P0340=1 (P0320=0; result in r0331).
- If the deviation of the magnetizing current is too high, then the values for the magnetizing reactance and those of the rotor resistance will not be able to be accurately determined.
- Especially for **third-party motors** it is important that the magnetizing current that is determined, is carefully checked and if required, appropriately corrected.

The procedure to manually determine the magnetizing current and to re-calculate the equivalent circuit diagram data when the drive is operated with closed-loop vector control (P1300 = 20/21) is shown in the following.



**Quick commissioning routine**

Using the quick commissioning routine the frequency inverter is adapted to the motor and important technology parameters are set.

**Motor data identification routine**

Using the motor data identification routine motor equivalent circuit diagram data is determined using a measuring technique.

**Determining the magnetizing current**

In order to determine the magnetizing current (P0320/r0331), the motor should be accelerated **up to approximately 80%** of its rated speed **under no-load operating conditions**.

In so doing, the following conditions must be carefully maintained:

- the vector control must be activated, P1300 = 20.21
- no field weakening (r0056.8 = 0)
- flux setpoint, r1598 = 100 %
- no efficiency optimization, P1580 = 0 %

**No-load operation means that the motor is operated without a load (i.e. no coupled driven machine).**

Under steady-state conditions, a current r0027 is obtained that approximately corresponds to the rated magnetizing current r0331. (the current is always less than the no-load current for a pure V/f control).

Measuring and entering the magnetizing current and therefore the associated new calculation of the equivalent circuit diagram data of the motor is an iterative procedure. It must be repeated at least 2-3 times until the following **criteria** are fulfilled:

- The more accurate the value of the magnetizing current that was entered, the better the **flux setpoint (r1598=100%)** matches the **flux actual value (r0084=96..104%)** of the observer model.
- The **output Xm adaptation (r1787)** of the observer model should be as low as possible. Good values lie between **1-5%**. The less that the Xh adaptation of the observer must operate, the sensitivity of the motor parameters after power failures are that much less sensitive.

**NOTE**

In order to display r0084 at the BOP/AOP, the LEVEL 4 parameters must be enabled using service parameter P3950=46.

**Calculating P0320**

0

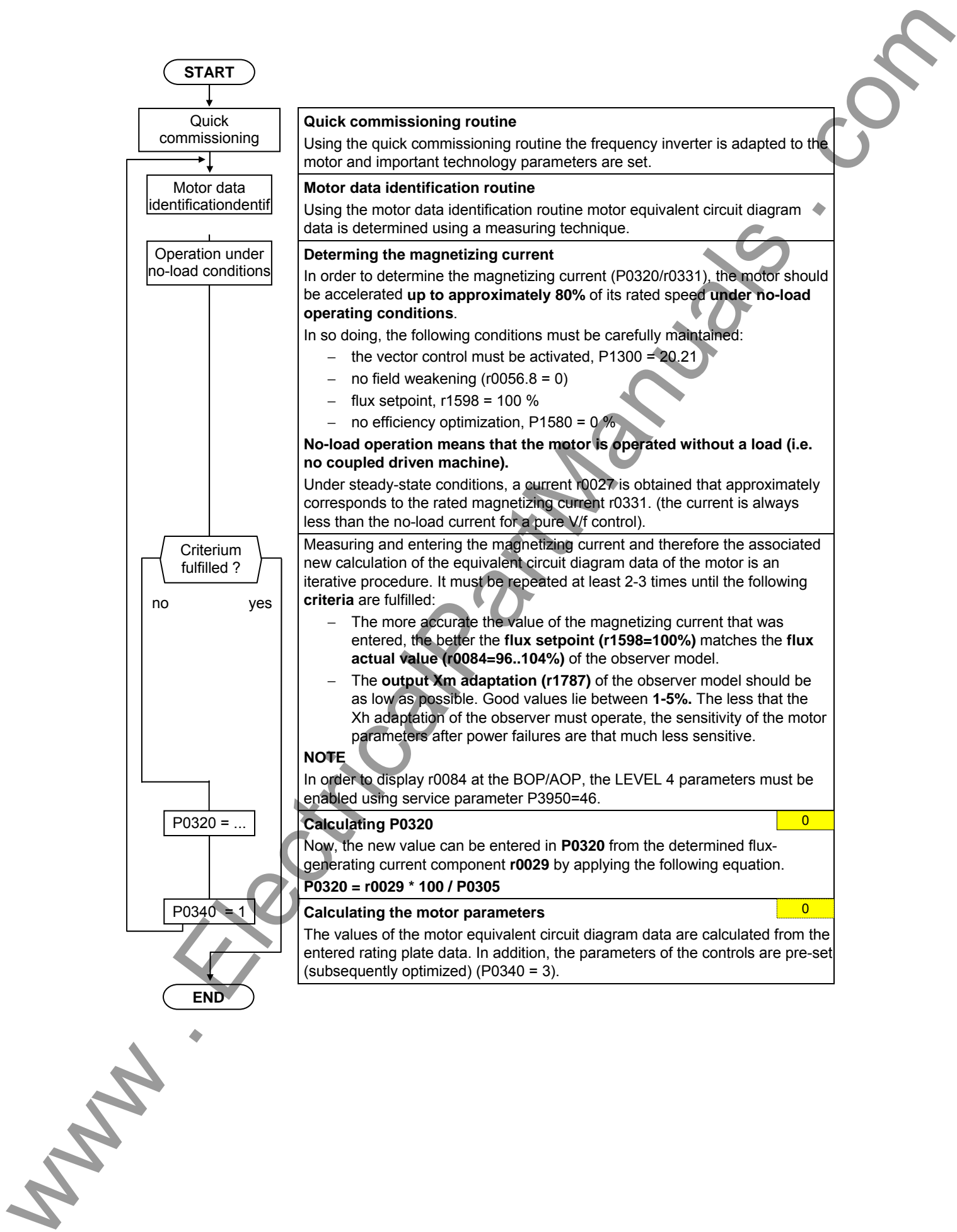
Now, the new value can be entered in **P0320** from the determined flux-generating current component **r0029** by applying the following equation.

$$P0320 = r0029 * 100 / P0305$$

**Calculating the motor parameters**

0

The values of the motor equivalent circuit diagram data are calculated from the entered rating plate data. In addition, the parameters of the controls are pre-set (subsequently optimized) (P0340 = 3).



### 3.5.7 Commissioning the application

After the motor – drive inverter combination was commissioned using the quick or series commissioning, in the following step parameters should be adapted and set according to the technological requirements. As an example, the following points should be considered:

- Functional requirements of the drive inverter (e.g. closed-loop process control with PID controller)
- Limit values
- Dynamic requirements
- Starting torques
- Load surge requirement
- Overload
- Diagnostics

If the application includes a function, which is not covered by the quick or series commissioning, then the following sections of the function description or the parameter list should be considered.

#### Adapting the drive inverter to the application

The parameters designated with \* offer more setting possibilities than are listed here. Refer to the parameter list for additional setting possibilities.

START	<b>Factory setting</b>								
↓									
P0003 = 3	<table border="1"> <tr> <td><b>User access level *</b></td> <td style="text-align: center;">1</td> </tr> <tr> <td>1 Standard: Allows access into most frequently used parameters</td> <td></td> </tr> <tr> <td>2 Extended: Allows extended access e.g. to inverter I/O functions</td> <td></td> </tr> <tr> <td>3 Expert (For expert use only)</td> <td></td> </tr> </table>	<b>User access level *</b>	1	1 Standard: Allows access into most frequently used parameters		2 Extended: Allows extended access e.g. to inverter I/O functions		3 Expert (For expert use only)	
<b>User access level *</b>	1								
1 Standard: Allows access into most frequently used parameters									
2 Extended: Allows extended access e.g. to inverter I/O functions									
3 Expert (For expert use only)									

#### 3.5.7.1 Serial Interface (USS)

P2010 =...	<table border="1"> <tr> <td><b>USS baud rate</b></td> <td style="text-align: center;">6</td> <td rowspan="4"><b>Possible Settings:</b></td> </tr> <tr> <td>Sets baud rate for USS communication.</td> <td></td> </tr> <tr> <td><b>USS address</b></td> <td style="text-align: center;">0</td> </tr> <tr> <td>Sets unique address for inverter.</td> <td></td> </tr> <tr> <td style="text-align: center;">↓</td> <td></td> <td></td> </tr> <tr> <td style="text-align: center;">P2011 =...</td> <td></td> <td></td> </tr> <tr> <td style="text-align: center;">↓</td> <td></td> <td></td> </tr> <tr> <td style="text-align: center;">P2012 =...</td> <td> <table border="1"> <tr> <td><b>USS PZD length</b></td> <td style="text-align: center;">2</td> <td></td> </tr> <tr> <td>Defines the number of 16-bit words in PZD part of USS telegram.</td> <td></td> <td></td> </tr> <tr> <td style="text-align: center;">↓</td> <td></td> <td></td> </tr> <tr> <td style="text-align: center;">P2013 =...</td> <td> <table border="1"> <tr> <td><b>USS PKW length</b></td> <td style="text-align: center;">127</td> <td></td> </tr> <tr> <td>Defines the number of 16-bit words in PKW part of USS telegram.</td> <td></td> <td></td> </tr> </table> </td> </tr> </table> </td> <td></td> </tr> </table>	<b>USS baud rate</b>	6	<b>Possible Settings:</b>	Sets baud rate for USS communication.		<b>USS address</b>	0	Sets unique address for inverter.		↓			P2011 =...			↓			P2012 =...	<table border="1"> <tr> <td><b>USS PZD length</b></td> <td style="text-align: center;">2</td> <td></td> </tr> <tr> <td>Defines the number of 16-bit words in PZD part of USS telegram.</td> <td></td> <td></td> </tr> <tr> <td style="text-align: center;">↓</td> <td></td> <td></td> </tr> <tr> <td style="text-align: center;">P2013 =...</td> <td> <table border="1"> <tr> <td><b>USS PKW length</b></td> <td style="text-align: center;">127</td> <td></td> </tr> <tr> <td>Defines the number of 16-bit words in PKW part of USS telegram.</td> <td></td> <td></td> </tr> </table> </td> </tr> </table>	<b>USS PZD length</b>	2		Defines the number of 16-bit words in PZD part of USS telegram.			↓			P2013 =...	<table border="1"> <tr> <td><b>USS PKW length</b></td> <td style="text-align: center;">127</td> <td></td> </tr> <tr> <td>Defines the number of 16-bit words in PKW part of USS telegram.</td> <td></td> <td></td> </tr> </table>	<b>USS PKW length</b>	127		Defines the number of 16-bit words in PKW part of USS telegram.			
<b>USS baud rate</b>	6	<b>Possible Settings:</b>																																					
Sets baud rate for USS communication.																																							
<b>USS address</b>	0																																						
Sets unique address for inverter.																																							
↓																																							
P2011 =...																																							
↓																																							
P2012 =...	<table border="1"> <tr> <td><b>USS PZD length</b></td> <td style="text-align: center;">2</td> <td></td> </tr> <tr> <td>Defines the number of 16-bit words in PZD part of USS telegram.</td> <td></td> <td></td> </tr> <tr> <td style="text-align: center;">↓</td> <td></td> <td></td> </tr> <tr> <td style="text-align: center;">P2013 =...</td> <td> <table border="1"> <tr> <td><b>USS PKW length</b></td> <td style="text-align: center;">127</td> <td></td> </tr> <tr> <td>Defines the number of 16-bit words in PKW part of USS telegram.</td> <td></td> <td></td> </tr> </table> </td> </tr> </table>	<b>USS PZD length</b>	2		Defines the number of 16-bit words in PZD part of USS telegram.			↓			P2013 =...	<table border="1"> <tr> <td><b>USS PKW length</b></td> <td style="text-align: center;">127</td> <td></td> </tr> <tr> <td>Defines the number of 16-bit words in PKW part of USS telegram.</td> <td></td> <td></td> </tr> </table>	<b>USS PKW length</b>	127		Defines the number of 16-bit words in PKW part of USS telegram.																							
<b>USS PZD length</b>	2																																						
Defines the number of 16-bit words in PZD part of USS telegram.																																							
↓																																							
P2013 =...	<table border="1"> <tr> <td><b>USS PKW length</b></td> <td style="text-align: center;">127</td> <td></td> </tr> <tr> <td>Defines the number of 16-bit words in PKW part of USS telegram.</td> <td></td> <td></td> </tr> </table>	<b>USS PKW length</b>	127		Defines the number of 16-bit words in PKW part of USS telegram.																																		
<b>USS PKW length</b>	127																																						
Defines the number of 16-bit words in PKW part of USS telegram.																																							

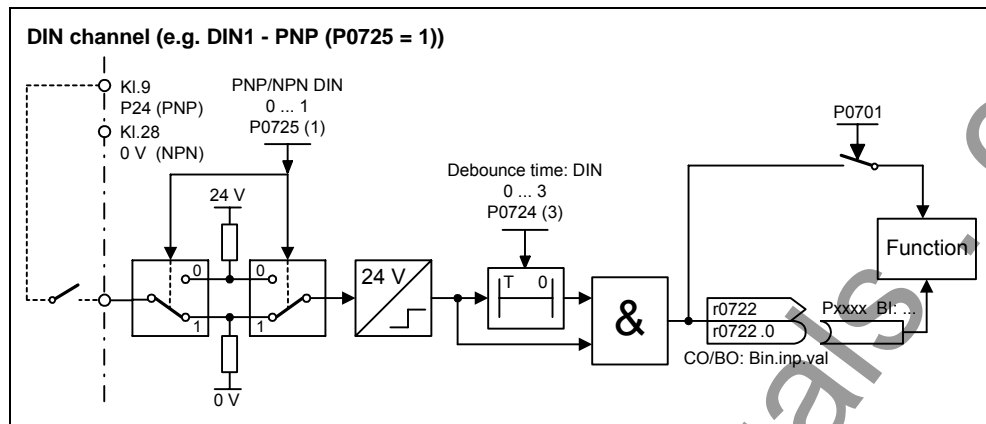
### 3.5.7.2 Selection of command source

<p>P0700 = ...</p>	<p><b>Selection of command source</b> <span style="float: right;">2</span></p> <p>Selects digital command source.</p> <ul style="list-style-type: none"> <li>0 Factory fault setting</li> <li>1 BOP (keypad)</li> <li>2 Terminal</li> <li>4 USS on BOP link</li> <li>5 USS on COM link</li> <li>6 CB on COM link</li> </ul>	<div style="display: flex; flex-direction: column; align-items: center;"> <div style="display: flex; gap: 5px;"> <div style="border: 1px solid black; padding: 2px;">BOP</div> <div style="border: 1px solid black; padding: 2px;">Terminals</div> </div> <div style="margin: 5px 0;">---</div> <div style="display: flex; gap: 5px;"> <div style="border: 1px solid black; padding: 2px;">USS BOP link</div> <div style="border: 1px solid black; padding: 2px;">USS COM link</div> <div style="border: 1px solid black; padding: 2px;">CB COM link</div> </div> </div> <div style="margin-top: 10px;"> <p>P0700 = 2</p> </div>
--------------------	---	--

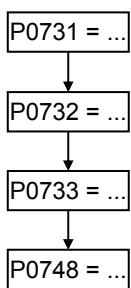
### 3.5.7.3 Digital input (DIN)

<p>P0701 = ...</p>	<p><b>Function digital input 1</b> <span style="float: right;">1</span></p> <p>Terminal 5</p> <ul style="list-style-type: none"> <li>1 ON / OFF1</li> </ul>	<p><b>Possible Settings:</b></p> <ul style="list-style-type: none"> <li>0 Digital input disabled</li> <li>1 ON / OFF1</li> <li>2 ON + Reverse / OFF1</li> <li>3 OFF2 – coast to standstill</li> <li>4 OFF3 – quick ramp-down</li> <li>9 Fault acknowledge</li> <li>10 JOG right</li> <li>11 JOG left</li> <li>12 Reverse</li> <li>13 MOP up (increase frequency)</li> <li>14 MOP down (decrease frequency)</li> <li>15 Fixed setpoint (Direct selection)</li> <li>16 Fixed setpoint (Direct selection + ON)</li> <li>17 Fixed setpoint (Binary coded selection + ON)</li> <li>21 Local/remote</li> <li>25 DC brake enable</li> <li>29 External trip</li> <li>33 Disable additional freq setpoint</li> <li>99 Enable BICO parameterization</li> </ul>
<p>P0702 = ...</p>	<p><b>Function digital input 2</b> <span style="float: right;">12</span></p> <p>Terminal 6</p> <ul style="list-style-type: none"> <li>12 Reverse</li> </ul>	
<p>P0703 = ...</p>	<p><b>Function digital input 3</b> <span style="float: right;">9</span></p> <p>Terminal 7</p> <ul style="list-style-type: none"> <li>9 Fault acknowledge</li> </ul>	
<p>P0704 = ...</p>	<p><b>Function digital input 4</b> <span style="float: right;">15</span></p> <p>Terminal 8</p> <ul style="list-style-type: none"> <li>15 Fixed setpoint (Direct selection)</li> </ul>	
<p>P0705 = ...</p>	<p><b>Function digital input 5</b> <span style="float: right;">15</span></p> <p>Terminal 16</p> <ul style="list-style-type: none"> <li>15 Fixed setpoint (Direct selection)</li> </ul>	
<p>P0706 = ...</p>	<p><b>Function digital input 6</b> <span style="float: right;">15</span></p> <p>Terminal 17</p> <ul style="list-style-type: none"> <li>15 Fixed setpoint (Direct selection)</li> </ul>	
<p>P0707 = 0</p>	<p><b>Function digital input 7</b> <span style="float: right;">0</span></p> <p>Via analog input, Terminal 3</p> <ul style="list-style-type: none"> <li>0 Digital input disabled</li> </ul>	
<p>P0708 = 0</p>	<p><b>Function digital input 8</b> <span style="float: right;">0</span></p> <p>Via analog input, Terminal 10</p> <ul style="list-style-type: none"> <li>0 Digital input disabled</li> </ul>	
<p>P0724 = ...</p>	<p><b>Debounce time for digital inputs</b> <span style="float: right;">3</span></p> <p>Defines debounce time (filtering time) used for digital inputs.</p> <ul style="list-style-type: none"> <li>0 No debounce time</li> <li>1 2.5 ms debounce time</li> <li>2 8.2 ms debounce time</li> <li>3 12.3 ms debounce time</li> </ul>	
<p>P0725 = ...</p>	<p><b>PNP / NPN digital inputs</b> <span style="float: right;">1</span></p> <p>Change-over (toggles) between high active (PNP) and low active (NPN). This applies to all digital inputs simultaneously.</p> <ul style="list-style-type: none"> <li>0 NPN mode ==&gt; low active</li> <li>1 PNP mode ==&gt; high active</li> </ul>	

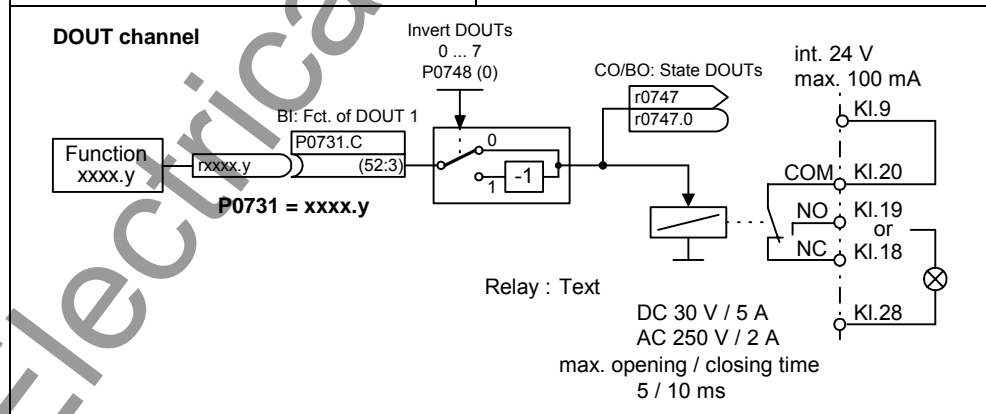
ON > 3,9 V, OFF < 1,7 V



### 3.5.7.4 Digital output (DOUT)



<b>BI: Function of digital output 1 *</b> 52.3	<b>Common Settings:</b>
Defines source of digital output 1.	52.0 Drive ready 0
<b>BI: Function of digital output 2 *</b> 52.7	52.1 Drive ready to run 0
Defines source of digital output 2.	52.2 Drive running 0
<b>BI: Function of digital output 3 *</b> 0.0	52.3 Drive fault active 0
Defines source of digital output 3.	52.4 OFF2 active 1
<b>Invert digital output</b> 0	52.5 OFF3 active 1
Defines high and low states of relay for a given function.	52.6 Switch on inhibit active 0
	52.7 Drive warning active 0
	52.8 Deviation, setpoint / actual value 1
	52.9 Control from PLC (PZD control) 0
	52.A Maximum frequency reached 0
	52.B Alarm: Motor current limiting 1
	52.C Motor holding brake (MHB) active 0
	52.D Motor overload 1
	52.E Motor direction of rotation, clockwise 0
	52.F Frequency inverter overload 1
	53.0 DC brake active 0



### 3.5.7.5 Selection of frequency setpoint

P1000 = ...

2

**Selection of frequency setpoint**

- 0 No main setpoint
- 1 MOP setpoint
- 2 Analog setpoint
- 3 Fixed frequency
- 4 USS on BOP link
- 5 USS on COM link
- 6 CB on COM link
- 7 Analog setpoint 2
- 10 No main setpoint + MOP setpoint
- 11 MOP setpoint + MOP setpoint
- 12 Analog setpoint + MOP setpoint
- ...
- 76 CB on COM link + Analog setpoint 2
- 77 Analog setpoint 2 + Analog setpoint 2

**NOTE**  
In addition to the main setpoint, a supplementary setpoint can be entered using P1000

**Example P1000 = 12 :**

P1000 = 12 ? P1070 = 755	P1070 CI: Main setpoint r0755 CO: Act. ADC after scal. [4000h]
P1000 = 12 ? P1075 = 1050	P1075 CI: Additional setpoint r1050 CO: Act. Output freq. of the MOP

P1074 = ...

0:0

**BI: Disable additional setpoint**  
Deaktiviert den Zusatzsollwert (ZUSW).

P1075 = ...

0:0

**CI: Additional setpoint**  
Defines the source of the additional setpoint which is added to the main setpoint.

**Common settings:**

- 755 Analog input setpoint
- 1024 Fixed frequency setpoint
- 1050 MOP setpoint

P1076 = ...

1:0

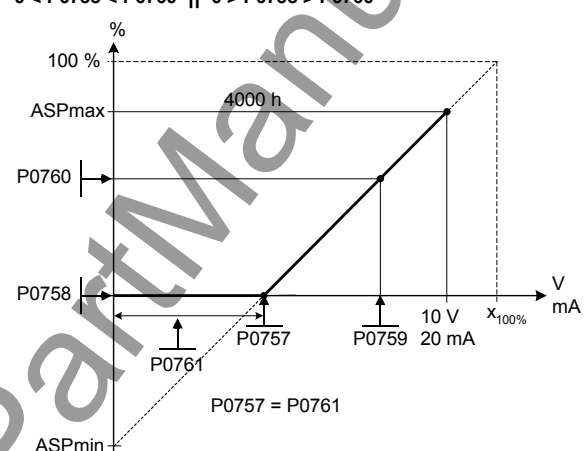
**CI: Additional setpoint scaling**  
Defines the source to scale the additional setpoint.

**Common settings:**

- 1 Scaling of 1.0 (100 %)
- 755 Analog input setpoint
- 1024 Fixed frequency setpoint
- 1050 MOP setpoint

### 3.5.7.6 Analog input (ADC)

<p>P0756 = ...</p> <p>↓</p> <p>P0757 = ...</p> <p>↓</p> <p>P0758 = ...</p> <p>↓</p> <p>P0759 = ...</p> <p>↓</p> <p>P0760 = ...</p> <p>↓</p> <p>P0761 = ...</p> <p>↓</p> <p>P0762 = ...</p>	<p><b>ADC type</b> <span style="float: right;">0</span></p> <p>Defines the analog input type and activates the monitoring function of the analog input.</p> <p>0 Unipolar voltage input (0 to +10 V)              1 Unipolar voltage input with monitoring (0 to 10 V)              2 Unipolar current input (0 to 20 mA)              3 Unipolar current input with monitoring (0 to 20 mA)              4 Bipolar voltage input (-10 to +10 V)</p> <p><b>NOTE</b></p> <p>For P0756 to P0760, the following applies:              Index 0 : Analog input 1 (ADC1), terminals 3, 4              Index 1 : Analog input 2 (ADC2), terminals 10, 11</p> <hr/> <p><b>Value x1 of ADC scaling</b> <span style="float: right;">0 V</span></p> <p><b>Value y1 of ADC scaling</b> <span style="float: right;">0.0 %</span></p> <p>This parameter represents the value of x1 as a % of P2000 (reference frequency).</p> <p><b>Value x2 of ADC scaling</b> <span style="float: right;">10 V</span></p> <p><b>Value y2 of ADC scaling</b> <span style="float: right;">100.0 %</span></p> <p>This parameter represents the value of x2 as a % of P2000 (reference frequency).</p> <p><b>Width of ADC deadband</b> <span style="float: right;">0 V</span></p> <p>Defines width of deadband on analog input.</p> <hr/> <p><b>Delay, ADC signal loss</b> <span style="float: right;">10 ms</span></p> <p>Defines the delay time between the loss of the analog setpoint and fault message F0080 being displayed.</p> <hr/> <p><b>ADC channel</b></p>
--	--

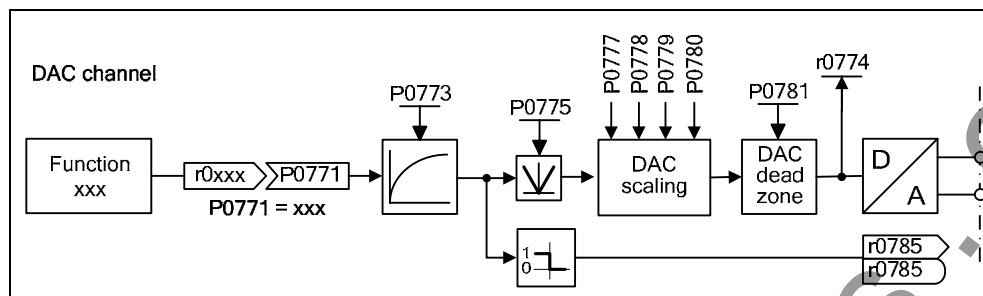


www.ElectricalPartManuals.com

## 3.5.7.7 Analog output (DAC)

P0771 = ...	<b>CI: DAC</b> <span style="float: right;">21</span> Defines function of the 0 - 20 mA analog output. 21 CO: Output frequency (scaled according to P2000) 24 CO: Frequency inverter output frequency (scaled according to P2000) 25 CO: Output voltage (scaled according to P2001) 26 CO: DC link voltage (scaled according to P2001) 27 CO: Output current (scaled according to P2002) <b>NOTE</b> For P0771 to P0781, the following applies: Index 0 : Analog output 1 (DAC1), terminals 12, 13 Index 1 : Analog output 2 (DAC2), terminals 26, 27
P0773 = ...	<b>Smooth time DAC</b> <span style="float: right;">2 ms</span> Defines smoothing time [ms] for analog output signal. This parameter enables smoothing for DAC using a PT1 filter.
P0775 = ...	<b>Permit absolute value</b> Decides if the absolute value of the analog output is used. If enabled, this parameter will take the absolute value of the value to be outputted. If the value was originally negative then the corresponding bit in r0785 is set, otherwise it is cleared. 0 OFF 1 ON
P0776 = ...	<b>DAC type</b> <span style="float: right;">0</span> Defines the analog output type. 0 Current output 1 Voltage output <b>NOTE</b> <ul style="list-style-type: none"> <li>P0776 changes the scaling of r0774 (0 – 20 mA ↔ 0 – 10 V)</li> <li>Scaling parameters P0778, P0780 and the dead zone are always entered in 0 – 20 mA</li> </ul> For the DAC as voltage output, the DAC outputs must be terminated using a 500 Ω resistor
P0777 = ...	<b>Value x1 of DAC scaling</b> <span style="float: right;">0.0 %</span> Defines the output characteristic value x1 as a %. This parameter represents the lowest analog value as a % of P200x (depending on the setting of P0771).
P0778 = ...	<b>Value y1 of DAC scaling</b> <span style="float: right;">0</span> This parameter represents the value for x1 in mA.
P0779 = ...	<b>Value x2 of DAC scaling</b> <span style="float: right;">100.0 %</span> Defines the output characteristic value x2 as a %. This parameter represents the lowest analog value as a % of P200x (depending on the setting of P0771).
P0780 = ...	<b>Value y2 of DAC scaling</b> <span style="float: right;">20</span> This parameter represents the value for x2 in mA.
P0781 = ...	<b>Width of DAC deadband</b> <span style="float: right;">0</span> Sets width of deadband in [mA] for analog output.

The graph plots current in mA on the y-axis against the percentage of P200x on the x-axis. The y-axis has a mark at 20 mA. The x-axis has marks at P0777 (x1), P0779 (x2), and 100%. The curve starts at 0 mA for 0% to x1, then rises linearly from (x1, y1) to (x2, y2), and finally remains constant at 20 mA from x2 to 100%. Dotted lines connect these points to the axes. Labels P0778 (y1), P0780 (y2), and P0781 (y1) are placed on the y-axis corresponding to the points on the curve.



### 3.5.7.8 Motor potentiometer (MOP)

<p>P1031 = ...</p> <p>↓</p> <p>P1032 = ...</p> <p>↓</p> <p>P1040 = ...</p>	<p><b>Setpoint memory of the MOP</b> <span style="float: right;">0</span></p> <p>Saves last motor potentiometer setpoint (MOP) that was active before OFF command or power down.</p> <p>0 MOP setpoint will not be stored</p> <p>1 MOP setpoint will be stored (P1040 is updated)</p>																								
	<p><b>Inhibit negative MOP setpoints</b> <span style="float: right;">1</span></p> <p>0 Neg. MOP setpoint is allowed</p> <p>1 Neg. MOP setpoint inhibited</p>																								
	<p><b>Setpoint of the MOP</b> <span style="float: right;">5.00 Hz</span></p> <p>Determines setpoint for motor potentiometer control.</p>																								
<p>MOP ramp-up and ramp-down times are defined by the parameters P1120 and P1121.</p>																									
<p>Possible parameter settings for the selection of MOP:</p> <table border="1"> <thead> <tr> <th></th> <th>Selection</th> <th>MOP up</th> <th>MOP down</th> </tr> </thead> <tbody> <tr> <td><b>DIN</b></td> <td>P0719 = 0, P0700 = 2, P1000 = 1 or P0719 = 1, P0700 = 2</td> <td>P0702 = 13 (DIN2)</td> <td>P0703 = 14 (DIN3)</td> </tr> <tr> <td><b>BOP</b></td> <td>P0719 = 0, P0700 = 1, P1000 = 1 or P0719 = 11</td> <td>UP button</td> <td>DOWN button</td> </tr> <tr> <td><b>USS on BOP link</b></td> <td>P0719 = 0, P0700 = 4, P1000 = 1 or P0719 = 41</td> <td>USS control word r2032 Bit13</td> <td>USS control word r2032 Bit14</td> </tr> <tr> <td><b>USS on COM link</b></td> <td>P0719 = 0, P0700 = 5, P1000 = 1 or P0719 = 51</td> <td>USS control word r2036 Bit13</td> <td>USS control word r2036 Bit14</td> </tr> <tr> <td><b>CB</b></td> <td>P0719 = 0, P0700 = 6, P1000 = 1 or P0719 = 61</td> <td>CB control word r2090 Bit13</td> <td>CB control word r2090 Bit14</td> </tr> </tbody> </table>			Selection	MOP up	MOP down	<b>DIN</b>	P0719 = 0, P0700 = 2, P1000 = 1 or P0719 = 1, P0700 = 2	P0702 = 13 (DIN2)	P0703 = 14 (DIN3)	<b>BOP</b>	P0719 = 0, P0700 = 1, P1000 = 1 or P0719 = 11	UP button	DOWN button	<b>USS on BOP link</b>	P0719 = 0, P0700 = 4, P1000 = 1 or P0719 = 41	USS control word r2032 Bit13	USS control word r2032 Bit14	<b>USS on COM link</b>	P0719 = 0, P0700 = 5, P1000 = 1 or P0719 = 51	USS control word r2036 Bit13	USS control word r2036 Bit14	<b>CB</b>	P0719 = 0, P0700 = 6, P1000 = 1 or P0719 = 61	CB control word r2090 Bit13	CB control word r2090 Bit14
	Selection	MOP up	MOP down																						
<b>DIN</b>	P0719 = 0, P0700 = 2, P1000 = 1 or P0719 = 1, P0700 = 2	P0702 = 13 (DIN2)	P0703 = 14 (DIN3)																						
<b>BOP</b>	P0719 = 0, P0700 = 1, P1000 = 1 or P0719 = 11	UP button	DOWN button																						
<b>USS on BOP link</b>	P0719 = 0, P0700 = 4, P1000 = 1 or P0719 = 41	USS control word r2032 Bit13	USS control word r2032 Bit14																						
<b>USS on COM link</b>	P0719 = 0, P0700 = 5, P1000 = 1 or P0719 = 51	USS control word r2036 Bit13	USS control word r2036 Bit14																						
<b>CB</b>	P0719 = 0, P0700 = 6, P1000 = 1 or P0719 = 61	CB control word r2090 Bit13	CB control word r2090 Bit14																						

### 3.5.7.9 Fixed frequency (FF)

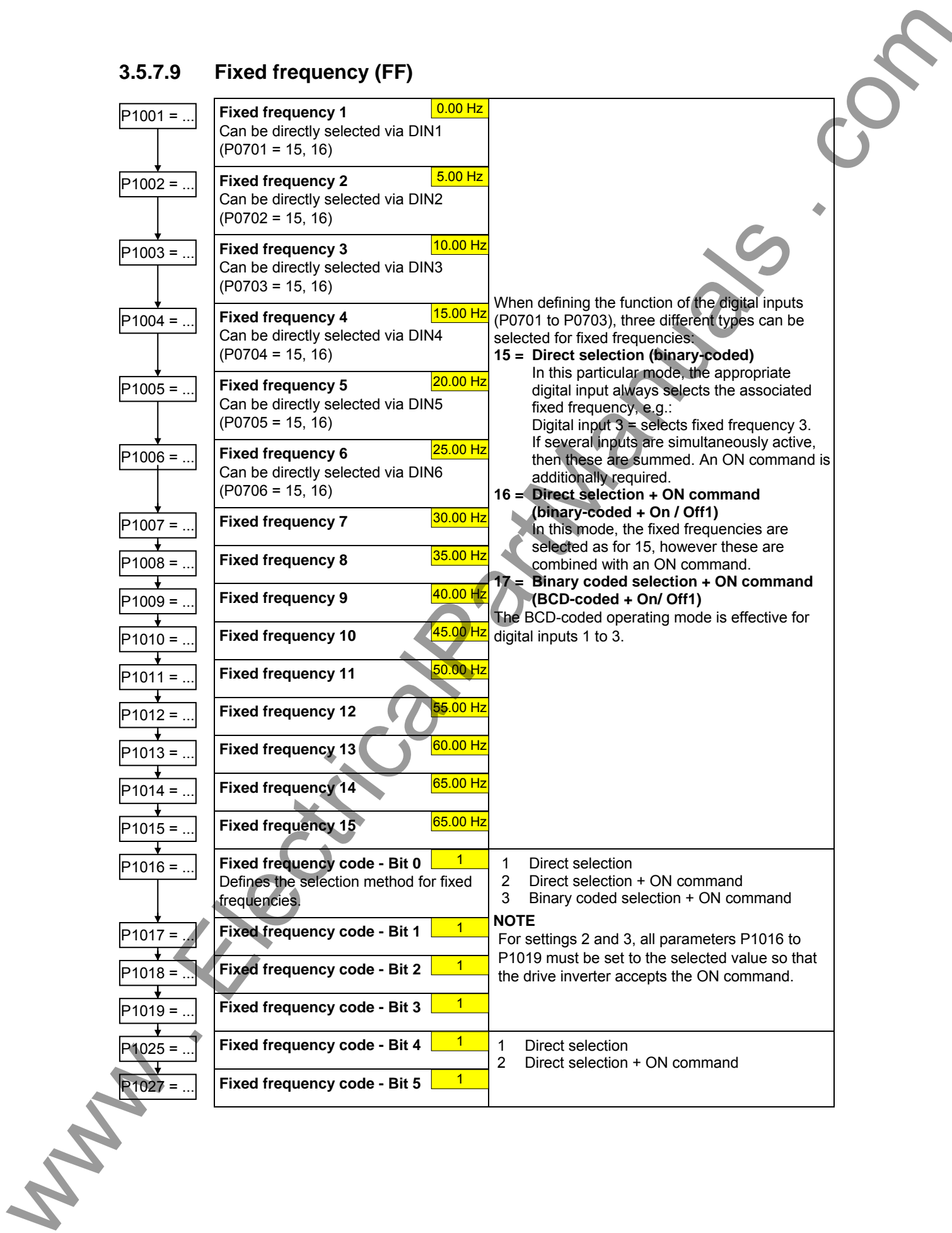
P1001 = ...	<b>Fixed frequency 1</b> 0.00 Hz Can be directly selected via DIN1 (P0701 = 15, 16)	
P1002 = ...	<b>Fixed frequency 2</b> 5.00 Hz Can be directly selected via DIN2 (P0702 = 15, 16)	
P1003 = ...	<b>Fixed frequency 3</b> 10.00 Hz Can be directly selected via DIN3 (P0703 = 15, 16)	
P1004 = ...	<b>Fixed frequency 4</b> 15.00 Hz Can be directly selected via DIN4 (P0704 = 15, 16)	
P1005 = ...	<b>Fixed frequency 5</b> 20.00 Hz Can be directly selected via DIN5 (P0705 = 15, 16)	
P1006 = ...	<b>Fixed frequency 6</b> 25.00 Hz Can be directly selected via DIN6 (P0706 = 15, 16)	
P1007 = ...	<b>Fixed frequency 7</b> 30.00 Hz	
P1008 = ...	<b>Fixed frequency 8</b> 35.00 Hz	
P1009 = ...	<b>Fixed frequency 9</b> 40.00 Hz	
P1010 = ...	<b>Fixed frequency 10</b> 45.00 Hz	
P1011 = ...	<b>Fixed frequency 11</b> 50.00 Hz	
P1012 = ...	<b>Fixed frequency 12</b> 55.00 Hz	
P1013 = ...	<b>Fixed frequency 13</b> 60.00 Hz	
P1014 = ...	<b>Fixed frequency 14</b> 65.00 Hz	
P1015 = ...	<b>Fixed frequency 15</b> 65.00 Hz	
P1016 = ...	<b>Fixed frequency code - Bit 0</b> 1 Defines the selection method for fixed frequencies.	1 Direct selection 2 Direct selection + ON command 3 Binary coded selection + ON command
P1017 = ...	<b>Fixed frequency code - Bit 1</b> 1	<b>NOTE</b> For settings 2 and 3, all parameters P1016 to P1019 must be set to the selected value so that the drive inverter accepts the ON command.
P1018 = ...	<b>Fixed frequency code - Bit 2</b> 1	
P1019 = ...	<b>Fixed frequency code - Bit 3</b> 1	
P1025 = ...	<b>Fixed frequency code - Bit 4</b> 1	1 Direct selection 2 Direct selection + ON command
P1027 = ...	<b>Fixed frequency code - Bit 5</b> 1	

When defining the function of the digital inputs (P0701 to P0703), three different types can be selected for fixed frequencies:

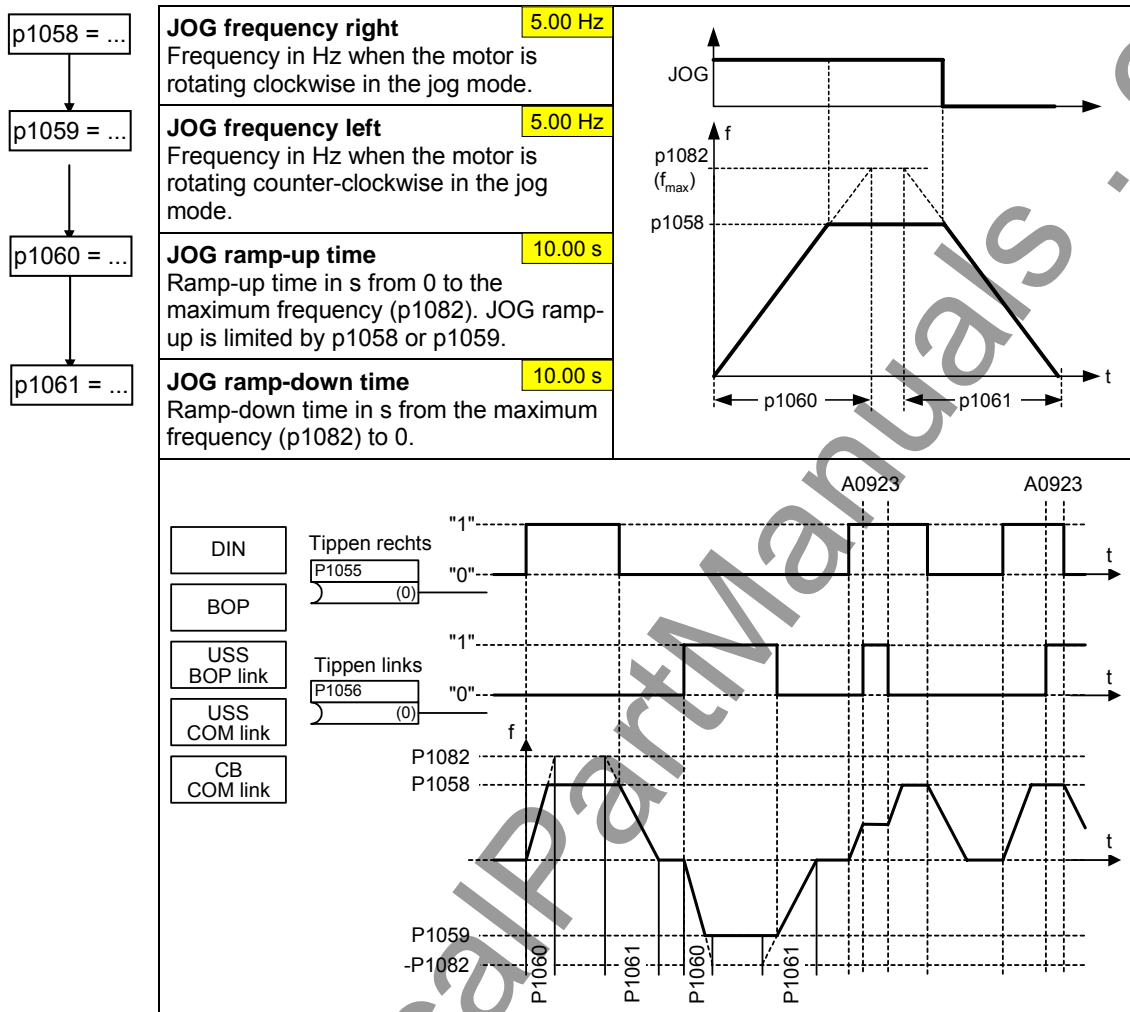
**15 = Direct selection (binary-coded)**  
In this particular mode, the appropriate digital input always selects the associated fixed frequency, e.g.:  
Digital input 3 = selects fixed frequency 3.  
If several inputs are simultaneously active, then these are summed. An ON command is additionally required.

**16 = Direct selection + ON command (binary-coded + On / Off1)**  
In this mode, the fixed frequencies are selected as for 15, however these are combined with an ON command.

**17 = Binary coded selection + ON command (BCD-coded + On/ Off1)**  
The BCD-coded operating mode is effective for digital inputs 1 to 3.

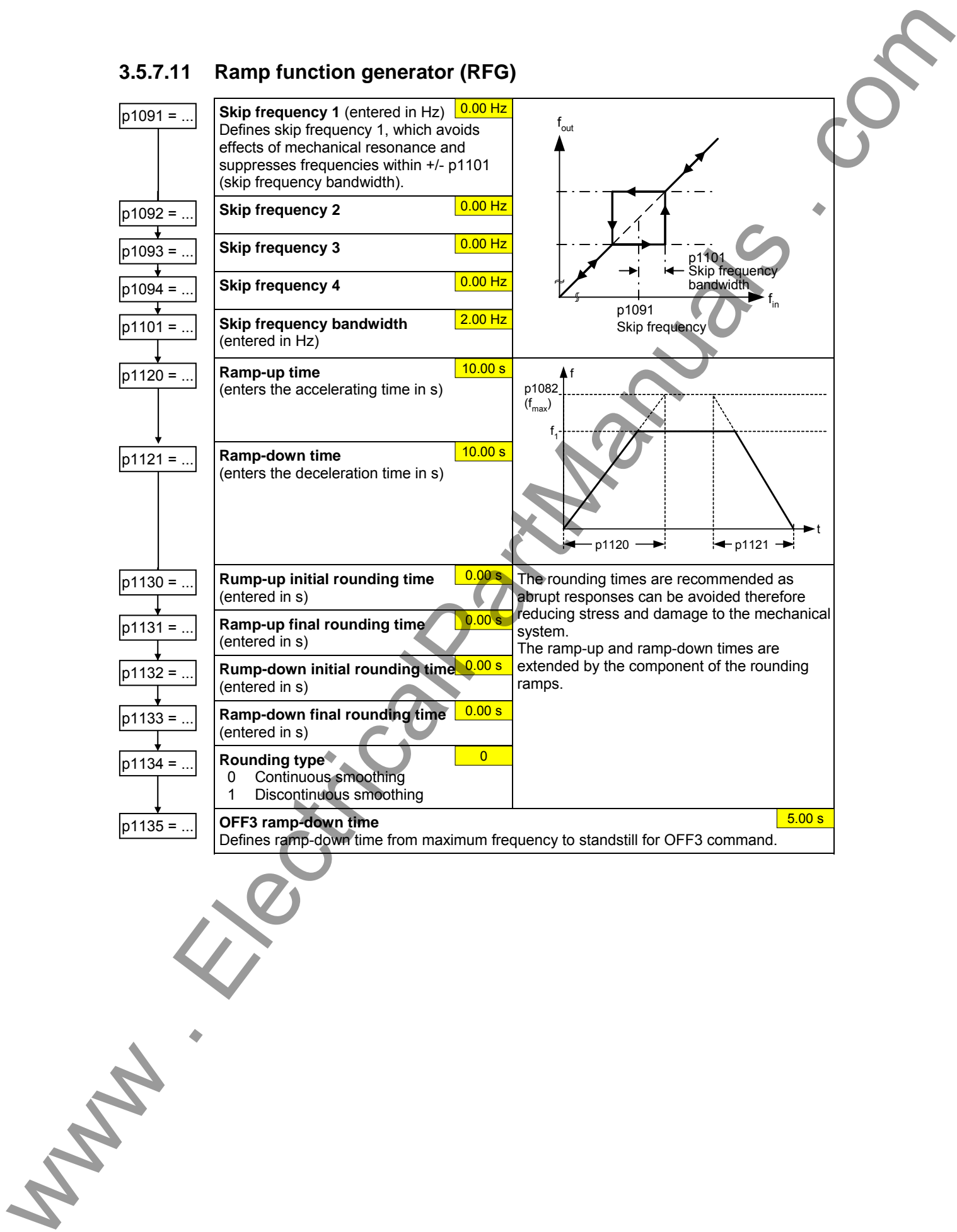


### 3.5.7.10 JOG



### 3.5.7.11 Ramp function generator (RFG)

p1091 = ...	<b>Skip frequency 1</b> (entered in Hz) 0.00 Hz Defines skip frequency 1, which avoids effects of mechanical resonance and suppresses frequencies within +/- p1101 (skip frequency bandwidth).	
p1092 = ...	<b>Skip frequency 2</b> 0.00 Hz	
p1093 = ...	<b>Skip frequency 3</b> 0.00 Hz	
p1094 = ...	<b>Skip frequency 4</b> 0.00 Hz	
p1101 = ...	<b>Skip frequency bandwidth</b> (entered in Hz) 2.00 Hz	
p1120 = ...	<b>Ramp-up time</b> (enters the accelerating time in s) 10.00 s	
p1121 = ...	<b>Ramp-down time</b> (enters the deceleration time in s) 10.00 s	<p>The rounding times are recommended as abrupt responses can be avoided therefore reducing stress and damage to the mechanical system. The ramp-up and ramp-down times are extended by the component of the rounding ramps.</p>
p1130 = ...	<b>Ramp-up initial rounding time</b> (entered in s) 0.00 s	
p1131 = ...	<b>Ramp-up final rounding time</b> (entered in s) 0.00 s	
p1132 = ...	<b>Ramp-down initial rounding time</b> (entered in s) 0.00 s	
p1133 = ...	<b>Ramp-down final rounding time</b> (entered in s) 0.00 s	
p1134 = ...	<b>Rounding type</b> 0 Continuous smoothing 1 Discontinuous smoothing	
p1135 = ...	<b>OFF3 ramp-down time</b> (entered in s) 5.00 s Defines ramp-down time from maximum frequency to standstill for OFF3 command.	



### 3.5.7.12 Reference/limit frequencies

p1080 = ...	<p><b>Min. frequency</b> (entered in Hz) <span style="float: right;">0.00 Hz</span></p> <p>Sets minimum motor frequency [Hz] at which motor will run irrespective of frequency setpoint. If the setpoint falls below the value of p1080, then the output frequency is set to p1080 taking into account the sign.</p>
↓	
p1082 = ...	<p><b>Max. frequency</b> (entered in Hz) <span style="float: right;">50.00 Hz</span></p> <p>Sets maximum motor frequency [Hz] at which motor will run irrespective of the frequency setpoint. If the setpoint exceeds the value p1082, then the output frequency is limited. The value set here is valid for both clockwise and anticlockwise rotation.</p>
↓	
p2000 = ...	<p><b>Reference frequency</b> (entered in Hz) <span style="float: right;">50.00 Hz</span></p> <p>The reference frequency in Hertz corresponds to a value of 100 %. This setting should be changed if a maximum frequency of higher than 50 Hz is required. It is automatically changed to 60 Hz if the standard 60 Hz frequency was selected using p0100.</p> <p><b>NOTE</b> This reference frequency effects the setpoint frequency as both the frequency setpoints via USS as well as via PROFIBUS (FB100) (4000H hex <math>\hat{=}</math> 100 % <math>\hat{=}</math> p2000) refer to this value.</p>
↓	
P2001 = ...	<p><b>Reference voltage</b> (entered in V) <span style="float: right;">1000 V</span></p> <p>The reference voltage in Volt (output voltage) corresponds to a value of 100 %.</p> <p><b>NOTE</b> This setting should only be changed if it is necessary to output the voltage with a different scaling.</p>
↓	
P2002 = ...	<p><b>Reference current</b> (entered in A) <span style="float: right;">0.10 A</span></p> <p>The reference current in Amps (output current) corresponds to a value of 100 %. Factory setting = 200 % of the rated motor current (P0305).</p> <p><b>NOTE</b> This setting should only be changed if it is necessary to output the current with a different scaling.</p>
↓	
P2003 = ...	<p><b>Reference torque</b> (entered in Nm) <span style="float: right;">0.12 Mn</span></p> <p>The reference torque in Nm corresponds to a value of 100 %. Factory setting = 200 % of the rated motor torque at a constant motor torque determined from the appropriate motor data.</p> <p><b>NOTE</b> This setting should only be changed if it is necessary to output the torque with a different scaling.</p>

### 3.5.7.13 Inverter protection

p0290 = ...

0

**Inverter overload reaction**  
 Selects reaction of inverter to an internal over-temperature.

- 0 Reduce output frequency
- 1 Trip (F0004 / F0005)
- 2 Reduce pulse frequency and output frequency
- 3 Reduce pulse frequency then trip (F0004)

Inverter monitoring

r0036 → i<sup>2</sup>t P0294

r0037 → Heat sink temperature P0292

IGBT temperature P0292

Inverter overload reaction P0290

i\_max control (U/f)  
Current control (SLVC, VC)

f\_pulse control

A0504

A0505

A0506

F0004

F0005

P0292 = ...

15 °C

**Inverter temperature warning**  
 Defines the temperature difference (in °C) between the Overtemperature trip threshold and the warning threshold of the inverter. The trip threshold is stored internally by the inverter and cannot be changed by the user.

Temperature warning threshold of inverter T<sub>warn</sub>  
 $T_{warn} = T_{trip} - P0292$

Temperature shutdown threshold of inverter T<sub>trip</sub>

Temperature	MM440, Frame Size							
	A - C	D - F	F 600 V	FX 95 kW CT	FX 110 kW CT	FX 132 kW CT	GX 160 kW CT	GX 200 kW CT
Heat sink	110 °C	95 °C	80 °C	88 °C	91 °C	80 °C	82 °C	88 °C
IGBT	140 °C	145 °C	145 °C	150 °C	150 °C	145 °C	147 °C	150 °C
Input rectifier	-	-	-	75 °C	75 °C	75 °C	75 °C	75 °C
Cooling air	-	-	-	55 °C	55 °C	55 °C	55 °C	50 °C
Control board	-	-	-	65 °C	65 °C	65 °C	65 °C	65 °C

P0295 = ...

0 s

### 3.5.7.14 Motor protection

In addition to the thermal motor protection, the motor temperature is also included in the adaptation of the motor equivalent circuit diagram data. Especially for a high thermal motor load, this adaptation has a significant influence on the degree of stability of the closed-loop vector control. For MM440 the motor temperature can only be measured using a KTY84 sensor. For the parameter setting P0601 = 0, 1, the motor temperature is calculated / estimated using the thermal motor model.

If the frequency inverter is permanently supplied with an external 24V voltage, then the motor temperature is also tracked/corrected using the motor temperature time constant – even when the line supply voltage is switched-out.

A high thermal motor load and when the line supply is frequently switched-out/switched-in requires, for closed-loop vector control

- that a KTY84 sensor is used, or
- an external 24V power supply voltage is connected

P0335 = ...	<p><b>Motor cooling</b> (Selects motor cooling system used) <span style="float: right; background-color: yellow;">0</span></p> <p>0 Self-cooled: Using shaft mounted fan attached to motor                  1 Force-cooled: Using separately powered cooling fan                  2 Self-cooled and internal fan                  3 Force-cooled and internal fan</p>
P0601 = ...	<p><b>Motor temperature sensor</b> <span style="float: right; background-color: yellow;">0</span></p> <p>Selects the motor temperature sensor.</p> <p>0 No sensor                  1 PTC thermistor (PTC)                  2 KTY84</p> <p>When "no sensor" or "PTC thermistor (PTC)" is selected, the motor temperature is determined on the basis of the value estimated by the thermal motor model.</p> <div style="text-align: center;"> </div>
P0604 = ...	<p><b>Alarm threshold, motor overtemperature</b> <span style="float: right; background-color: yellow;">130.0 °C</span></p> <p>Defines the alarm threshold for the motor overtemperature protection. This threshold, where either a shutdown (trip) or I<sub>max</sub> reduction is initiated (P0610) always lies 10 % above the alarm threshold.</p> <p><math>\vartheta_{trip} = 1.1 \cdot \vartheta_{warn} = 1.1 \cdot P0604</math>     <math>\vartheta_{warn}</math> : Warning threshold (P0604)  <math>\vartheta_{trip}</math> : Trip threshold (max. permissible temperature)</p> <p>The alarm threshold should be at least 40 °C greater than the ambient temperature P0625.  <math>P0604 \geq P0625 + 40 \text{ °C}</math></p>
P0610 = ...	<p><b>Inverter temperature reaction</b> <span style="float: right; background-color: yellow;">2</span></p> <p>Defines reaction when motor temperature reaches warning threshold.</p> <p>0 No reaction, warning only                  1 Warning and I<sub>max</sub> reduction (results in a lower output frequency)                  2 Warning and trip (F0011)</p>
p0640 = ...	<p><b>Motor overload factor [%]</b> <span style="float: right; background-color: yellow;">150.0 %</span></p> <p>Defines motor overload current limit in [%] relative to p0305 (rated motor current). Limited to maximum inverter current or to 400 % of rated motor current (p0305), whichever is the lower.</p>

### 3.5.7.15 Encoder

P0400 = ...

<b>Select encoder type</b> <span style="float: right;">0</span>			
Selects the encoder type.			
0 Inhibited 1 Single-track pulse encoder 2 Two-track pulse encoder			
The table shows the values of P0400 as a function of the number of tracks:			
Parameter	Terminal	Track	Encoder output
P0400 = 1	A		single ended
	AN		differential
P0400 = 2	A		single ended
	B		single ended
	A		differential
	AN		differential

In order to guarantee reliable operation, the DIP switches on the encoder module must be set as follows depending on the encoder type (TTL, HTL) and encoder output:

Type	Output	
	single ended	differential
TTL (e.g. 1XP8001-2)	111111	010101
HTL (e.g. 1XP8001-1)	101010	000000



P0408 = ...

**Encoder pulses per revolution** 1024  
Specifies the number of encoder pulses per revolution.

P0491 = ...

**Reaction on speed signal loss** 0  
Defines the calculation method.  
0 No transition  
1 Transition into SLVC

P0492 = ...

**Allowed speed difference** 10.00 Hz  
Parameter P0492 defines the frequency threshold for the loss of the encoder signal (fault F0090).  
**CAUTION**  
p0492 = 0 (no monitoring function):  
With p0492 = 0, the loss of the encoder signal at high frequency as well as at a low frequency is de-activated. As a result, the system does not monitor for the loss of the encoder signal.

P0494 = ...

**Delay speed loss reaction** 10 ms  
P0492 is used to detect the loss of the encoder signal at low frequencies. If the motor speed is less than the value of P0492, the loss of the encoder signal is determined using an appropriate algorithm. P0494 defines the delay time between detecting the loss of the speed signal and initiating the appropriate response.  
**CAUTION**  
p0494 = 0 (no monitoring function):  
With p0494 = 0, the loss of the encoder signal at low frequencies is de-activated. As a result, at these frequencies, a loss of the encoder signal is not detected (loss of the encoder signal at high frequency remains active as long as parameter p0492 > 0).

### 3.5.7.16 V/f control

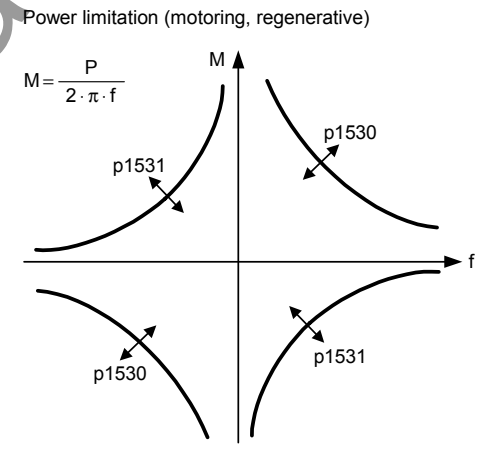
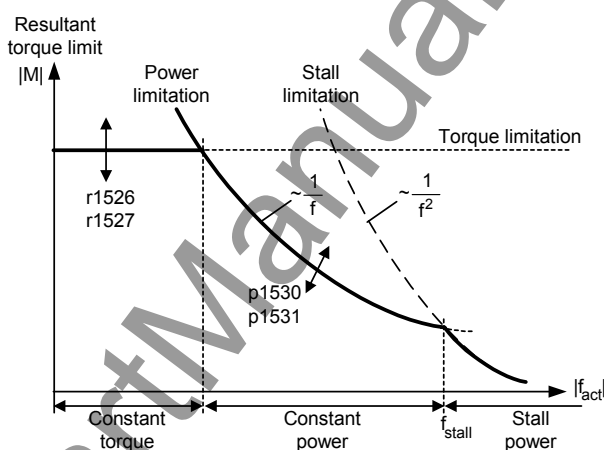
<p>P1300 =...</p>	<p><b>Control mode</b> <span style="float: right;">0</span></p> <p>The control type is selected using this parameter. For the "V/f characteristic" control type, the ratio between the frequency inverter output voltage and the frequency inverter output frequency is defined.</p> <ul style="list-style-type: none"> <li>0 V/f with linear</li> <li>1 V/f with FCC</li> <li>2 V/f with parabolic characteristic</li> <li>3 V/f with programmable characteristic (→ P1320 – P1325)</li> </ul>
<p>P1310 =...</p>	<p><b>Continuous boost</b> (entered in %) <span style="float: right;">50.00 %</span></p> <p>Voltage boost as a % relative to P0305 (rated motor current) and P0350 (stator resistance). P1310 is valid for all V/f versions (refer to P1300). At low output frequencies, the effective resistance values of the winding can no longer be neglected in order to maintain the motor flux.</p>
	<p>The graph shows the relationship between output voltage (V) and frequency (f) for linear V/f control. The y-axis represents voltage, with V<sub>max</sub> at the top and V<sub>n</sub> (P0304) at the base of the linear region. The x-axis represents frequency, with f<sub>Boost,end</sub> (P1316) marking the end of the boost region, f<sub>n</sub> (P0310) marking the start of the linear region, and f<sub>max</sub> (P1082) marking the maximum frequency. A dashed line represents the 'Normal V/f (P1300 = 0)', and a solid line represents the 'Output voltage' which includes a 'Boost voltage' at low frequencies. The boost voltage is shown as a shaded area between the normal V/f line and the actual output voltage line. Two levels of boost are indicated: V<sub>ConBoost,100</sub> and V<sub>ConBoost,50</sub>. To the right, three waveforms are shown over time (t): the first is a step function for 'ON' and 'OFF' commands; the second is the frequency  f , showing a ramp up, a dwell, and a ramp down; the third is the 'P1310 active' signal, which is high during the dwell and ramp-down phases.</p>
<p>P1311 =...</p>	<p><b>Acceleration boost</b> (entered in %) <span style="float: right;">0.0 %</span></p> <p>Voltage boost for accelerating/braking as a % relative to P0305 and P0350. P1311 only results in a voltage boost when ramping-up/ramp-down and generates an additional torque for accelerating/braking. Contrary to parameter P1312, that is only active for the 1<sup>st</sup> acceleration operation after the ON command, P1311 is effective each time that the drive accelerates or brakes.</p>
	<p>The graph shows the relationship between output voltage (V) and frequency (f) for acceleration boost. The axes and labels are similar to the linear V/f graph. The 'Ausgangsspannung' (output voltage) is shown as a shaded area above the 'U/f normal (P1300 = 0)' line during the acceleration and deceleration phases. The boost voltage is indicated as V<sub>ist,Boost</sub>. The 'Gültigkeitsbereich' (validity range) is shown as a shaded area. To the right, three waveforms are shown over time (t): the first is a step function for 'ON' and 'OFF' commands; the second is the frequency  f , showing a ramp up, a dwell, and a ramp down; the third is the 'P1311 aktiv' signal, which is high during the ramp-up and ramp-down phases.</p>

P1312 = ...	<p><b>Starting boost</b> (entered in %) <span style="float: right;">0.0 %</span></p> <p>Voltage boost when starting (after an ON command) when using the linear or square-law V/f characteristic as a % relative to P0305 (rated motor current) or P0350 (stator resistance). The voltage boost remains active until</p> <ol style="list-style-type: none"> <li>1) the setpoint is reached for the first time and</li> <li>2) the setpoint is reduced to a value that is less than the instantaneous ramp-function generator output.</li> </ol>
P1320 = ...	<p><b>Programmable V/f freq. coord. 1</b> <span style="float: right;">0.0 Hz</span></p> <p>Sets V/f coordinates (P1320/1321 to P1324/1325) to define V/f characteristic.</p>
P1321 = ...	<p><b>Programmable V/f volt. coord. 1</b> <span style="float: right;">0.0 Hz</span></p>
P1322 = ...	<p><b>Programmable V/f freq. coord. 2</b> <span style="float: right;">0.0 Hz</span></p>
P1323 = ...	<p><b>Programmable V/f volt. coord. 2</b> <span style="float: right;">0.0 Hz</span></p>
P1324 = ...	<p><b>Programmable U/f Freq. coord. 3</b> <span style="float: right;">0.0 Hz</span></p>
P1325 = ...	<p><b>Programmable V/f volt. coord. 3</b> <span style="float: right;">0.0 Hz</span></p>
	<p style="text-align: center;"> <math display="block">P1310[V] = \frac{P1310[\%]}{100[\%]} \cdot \frac{r0395[\%]}{100[\%]} \cdot P0304[V]</math> </p>
P1333 = ...	<p><b>Starting frequency for FCC</b> <span style="float: right;">10.0 %</span></p> <p>(entered as a %)</p> <p>Defines the FCC starting frequency as a function of the rated motor frequency (P0310).</p> $f_{FCC} = \frac{P0310}{100} \cdot P1333$ $f_{FCC+Hys} = \frac{P0310}{100} \cdot (P1333 + 6\%)$
	<p><b>NOTE</b></p> <p>The constant voltage boost P1310 is continually decreased analog to switching-in FCC.</p>
P1335 = ...	<p><b>Slip compensation</b> <span style="float: right;">0.0 %</span></p> <p>(entered in %)</p> <p>Dynamically adjusts output frequency of inverter so that motor speed is kept constant independent of motor load.</p>
	<p>Range of slip compensation :</p>
P1338 = ...	<p><b>Resonance damping gain V/f</b> <span style="float: right;">0.00</span></p> <p>Defines resonance damping gain for V/f.</p>

### 3.5.7.17 Field-orientated control

#### Limitations

<p>p0640 = ...</p>	<p><b>Motor overload factor [%]</b> <span style="float: right;">150.0 %</span></p> <p>Defines motor overload current limit in [%] relative to p0305 (rated motor current). Limited to maximum inverter current or to 400 % of rated motor current (p0305), whichever is the lower.</p> $p0640_{max} = \frac{\min(r0209, 4 \cdot p0305)}{p0305} \cdot 100$
<p>p1520 = ...</p>	<p><b>CO: Upper torque limit</b> <span style="float: right;">FC-spec.</span></p> <p>Specifies fixed value for upper torque limitation.</p> <p><math>P1520_{def} = 1.5 \cdot r0333</math>  <math>P1520_{max} = \pm 4 \cdot r0333</math></p>
<p>p1521 = ...</p>	<p><b>CO: Lower torque limit</b> <span style="float: right;">FC-spec.</span></p> <p>Enters fixed value of lower torque limitation.</p> <p><math>P1521_{def} = -1.5 \cdot r0333</math>  <math>P1521_{max} = \pm 4 \cdot r0333</math></p>
<p>p1530 = ...</p>	<p><b>Motoring power limitation</b> <span style="float: right;">FC-spec.</span></p> <p>Defines fixed value for the max. permissible motoring active power.</p> <p><math>P1530_{def} = 2.5 \cdot P0307</math>  <math>P1530_{max} = 3 \cdot P0307</math></p>
<p>p1531 = ...</p>	<p><b>Regenerative power limitation</b> <span style="float: right;">FC-spec.</span></p> <p>Enters fixed value for the max. permissible regenerative active power</p> <p><math>P1531_{def} = -2.5 \cdot P0307</math>  <math>P1531_{max} = -3 \cdot P0307</math></p>



**Sensorless vector control (SLVC)**

p1300=20	<p><b>Control mode</b> <span style="float: right;">0</span></p> <p>20 Closed-loop Vector control – speed without encoder                  SLVC can provide excellent performance for the following types of application:</p> <ul style="list-style-type: none"> <li>• Applications which require high torque performance</li> <li>• Applications which require fast respond to shock loading</li> <li>• Applications which require torque holding while passing through 0 Hz</li> <li>• Applications which require very accurate speed holding</li> <li>• Applications which require motor pull out protection</li> </ul>
p1452 = ...	<p><b>Filter time for act. freq (SLVC)</b> <span style="float: right;">4 ms</span></p> <p>Sets time constant of PT1 filter to filter the frequency deviation of speed controller in operation mode SLVC (sensorless vector control).</p> <p>Decreasing the value leads to a higher dynamic of the speed regulation. Instability is seen if the value is too low (or too high). p1452 = 2 can be set for most applications.</p>
p1470 = ...	<p><b>Gain speed controller (SLVC)</b> <span style="float: right;">3.0</span></p> <p>Enters gain of speed controller for sensorless vector control (SLVC).</p>
p1472 = ...	<p><b>Integral time n-ctrl. (SLVC)</b> <span style="float: right;">400 ms</span></p> <p>Enters integral time of speed controller for sensorless vector control (SLVC).</p>
<p style="text-align: right;">*) only active, if pre-control is enabled (p1496 &gt; 0)</p>	
p1610 = ...	<p><b>Continuous torque boost (SLVC)</b> <span style="float: right;">50.0 %</span></p> <p>Sets continuous torque boost in lower frequency range of SLVC (sensorless vector control). Value is entered in [%] relative to rated motor torque r0333.</p> <p>p1610 is only effective in the open-loop mode between 0 Hz and approx. ±p1755.</p>
p1611 = ...	<p><b>Acc. torque boost (SLVC)</b> <span style="float: right;">0.0 %</span></p> <p>Sets acceleration torque boost in lower frequency range of SLVC (sensorless vector control). Value is entered in [%] relative to rated motor torque r0333.</p> <p>p1611 is only effective in the open-loop mode between 0 Hz and approx. ±p1755.</p> <p>In opposite to p1610 the acceleration torque boost p1611 is only in operation during acceleration/deceleration.</p>

p1750 = ...

**Control word of motor model** 1

This parameter controls the operation of the sensorless vector control (SLVC) at very low frequencies. This therefore includes the following conditions:

Bit00 Start SLVC open loop	0 NO	1 YES
----------------------------	------	-------

(Operation directly after an ON command)

Bit01 Zero crossing SLVC open loop	0 NO	1 YES
------------------------------------	------	-------

(zero crossing)

**Start**

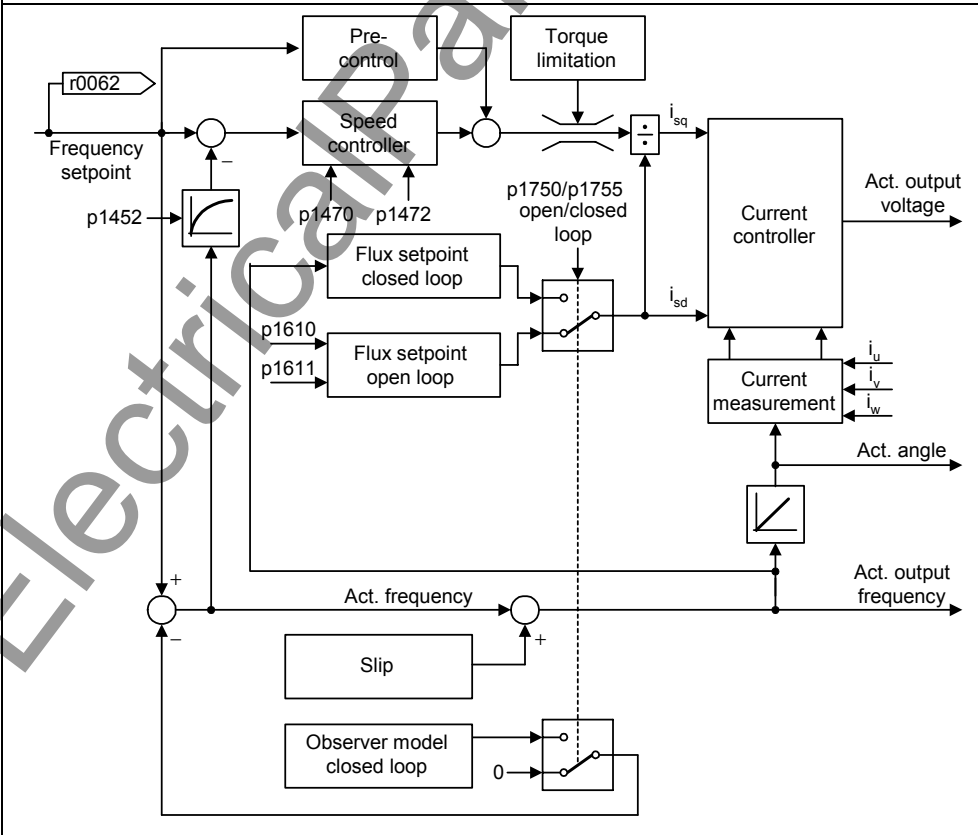
**Zero crossing**

For most applications the setting of parameter p1750 = 0 gives the best result at low frequency.

p1755 = ...

**Start-freq. motor model (SLVC)** 5.0 Hz

Enter the start frequency of sensorless vector control (SLVC), thereby SLVC switches over from open-loop to closed-loop at that frequency.



www.ElectricalManuals.com

### Vector control with encoder (VC)

- First step: Parameterizing the speed encoder (refer to Section 3.5.7.15)
- When commissioning Vector Control with encoder-feedback (VC), the drive should be configured for V/f mode (see p1300) first. Run the drive and compare r0061 with r0021 that should agree in:
  - sign
  - magnitude (with a deviation of only a few percent)
 Only if both criteria are fulfilled, change p1300 and select VC (p1300 = 21/23).
- Encoder loss detection must be disabled (p0492 = 0) if torque is limited externally., e.g.:
  - closed-loop winder control
  - traversing / moving to a fixed endstop
  - when using a mechanical brake

p1300=21

↓

p1442 = ...

↓

p1460 = ...

↓

p1462 = ...

<b>Control mode</b> 21 Vector control with sensor	0
<b>Filter time for act. speed</b> Sets time constant of PT1 filter to smooth actual speed of speed controller. Decreasing the value leads to a higher dynamic of the speed regulation. Instability is seen if the value is too low. p1442 = 2 can be set for most applications.	4 ms
<b>Gain speed controller</b> Enters gain of speed controller.	3.0
<b>Integral time speed controller</b> Enters integral time of speed controller.	400 ms

\*) only active, if pre-control is enabled (p1496 > 0)

### Supplementary torque setpoint

- In the vector mode – with / without encoder – the speed controller can be subordinate to a constant or variable supplementary torque.
- The supplementary setpoint can be used to advantage for hoisting gear with low intrinsic friction when starting in the vertical direction. The supplementary torque setpoint must always be impressed in the hoisting (raising) direction (please observe the sign!). As a result of the supplementary torque, also when lowering, a slip is immediately established that has a stabilizing effect on the closed-loop control (there is no significant load sag).
- The sign of the supplementary torque setpoint can be determined as follows in the commissioning phase with the appropriate care and taking into account all of the relevant safety regulations:  
Hoist (raise) a minimum load using the hoisting gear and read-out the sign from parameter r0079 (the sign of r0079 corresponds to the sign of the supplementary torque setpoint).
- An empirical value of approx. 40 % of the rated motor torque r0333 has lead to good results for existing hoisting gear (carefully observe the sign!).

P1511=...

**CI: Supplementary torque setpoint** 0:0

**Frequent settings:**  
 2889 Fixed setpoint 1 as a %  
 2890 Fixed setpoint 2 as a %  
 755.0 Analog input 1  
 755.1 Analog input 2  
 2015. 2 USS (BOP link)  
 2018. 2 USS (COM link)  
 2050. 2 CB (e.g. PROFIBUS)

CI: Add. trq. setp  
P1511.C  
> (0:0)

\*) only active, if pre-control is enabled (P1496 > 0)

	T <sub>i</sub>	K <sub>p</sub>	T <sub>n</sub>
SLVC:	P1452	P1470	P1472
VC:	P1442	P1460	P1462

### 3.5.7.18 Converter-specific Functions

#### Flying start

p1200 = ...	<b>Flying start</b> Starts inverter onto a spinning motor by rapidly changing the output frequency of the inverter until the actual motor speed has been found. 0 Flying start disabled 1 Flying start is always active, start in direction of setpoint 2 Flying start is active if power on, fault, OFF2, start in direction of setpoint 3 Flying start is active if fault, OFF2, start in direction of setpoint 4 Flying start is always active, only in direction of setpoint 5 Flying start is active if power on, fault, OFF2, only in direction of setpoint 6 Flying start is active if fault, OFF2, only in direction of setpoint	0
p1202 = ...	<b>Motor-current: Flying start</b> (entered in %) Defines search current used for flying start.	100 %
p1203 = ?	<b>Search rate: Flying start</b> (entered in %) Sets factor by which the output frequency changes during flying start to synchronize with turning motor.	100 %

#### Automatic restart

p1210 = ...	<b>Automatic restart</b> Configures automatic restart function. 0 Disabled 1 Trip reset after power on 2 Restart after mains blackout 3 Restart after mains brownout or fault 4 Restart after mains brownout 5 Restart after mains blackout and fault 6 Restart after mains brown/blackout or fault	1
-------------	---	---

## Holding brake

- Series / commissioning for hazardous loads
  - lower the load to the floor
  - when replacing the frequency inverter, prevent (inhibit) the frequency inverter from controlling the motor holding brake (MHB)
  - secure the load or inhibit the motor holding brake control (so that the brake cannot be controlled) and then – and only then – carry-out quick commissioning / parameter download using the PC-based tool (e.g. STARTER, AOP)
- Parameterize the weight equalization for hoisting gear applications
  - magnetizing time P0346 greater than zero
  - min. frequency P1080 should approximately correspond to the motor slip  $r0330$  ( $P1080 \approx r0330$ )
  - adapt the voltage boost to the load
    - a) V/f ( $P1300 = 0 \dots 3$ ): P1310, P1311
    - b) SLVC ( $P1300 = 20$ ): P1610, P1611
- It is not sufficient to just select the status signal r0052 bit 12 "motor holding brake active" in P0731 – P0733. In order to activate the motor holding brake, in addition, parameter P1215 must be set to 1.
- It is not permissible to use the motor holding brake as operating brake. The reason for this is that the brake is generally only dimensioned/designed for a limited number of emergency braking operations.
- The brake closing / opening times can be taken from the appropriate manual. The following typical values have been taken from Motor Catalog M11 2003/2004, Page 2/51:

Motor size	Brake type	Opening time [ms]	Closing time [ms]
63	2LM8 005-1NAxx	25	56
71	2LM8 005-2NAxx	25	56
80	2LM8 010-3NAxx	26	70
90	2LM8 020-4NAxx	37	90
100	2LM8 040-5NAxx	43	140
112	2LM8 060-6NAxx	60	210
132	2LM8 100-7NAxx	50	270
160	2LM8 260-8NAxx	165	340
180	2LM8 315-0NAxx	152	410
200 225	2LM8 400-0NAxx	230	390

P1215 =...

### Holding brake enable

0

Enables/disables holding brake function (MHB).

- 0 Motor holding brake disabled
- 1 Motor holding brake enabled

#### NOTE

The following must apply when controlling the brake relay via a digital output: P0731 = 52.C (= 52.12) (refer to Section 3.5.7.4 "Digital output (DOU)").

P0731=52.C

P0748 = 0

p1216 = ...

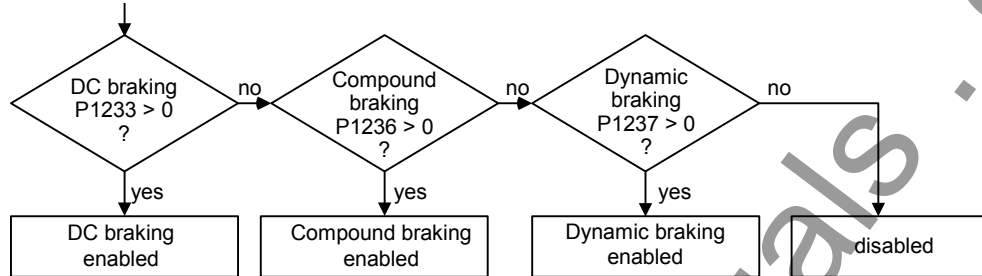
p1217 = ...

<p><b>BI: Fct digital output 1</b> <span style="float: right; background-color: yellow;">52.3</span></p> <p>Defines the source for digital output 1.</p> <p><b>NOTE</b> The brake relay can also be controlled from another digital output (if this is available) or using a distributed I/O module. Analog to DOUT 1, it should be guaranteed that the I/Os are controlled by the status bit "MHB active".</p>	<p><b>Frequent settings:</b></p> <table style="width: 100%; border-collapse: collapse;"> <tr><td>52.0</td><td>Ready to power-up</td><td>0</td><td>Closed</td></tr> <tr><td>52.1</td><td>Ready</td><td>0</td><td>Closed</td></tr> <tr><td>52.2</td><td>Drive operational</td><td>0</td><td>Closed</td></tr> <tr><td>52.3</td><td>Fault present</td><td>0</td><td>Closed</td></tr> <tr><td>52.4</td><td>OFF2 active (present)</td><td>1</td><td>Closed</td></tr> <tr><td>52.5</td><td>OFF3 active (present)</td><td>1</td><td>Closed</td></tr> <tr><td>52.6</td><td>Power-on inhibit active (present)</td><td>0</td><td>Closed</td></tr> <tr><td>52.7</td><td>Alarm active (present)</td><td>0</td><td>Closed</td></tr> <tr><td>52.8</td><td>Deviation, setpoint/actual value</td><td>1</td><td>Closed</td></tr> <tr><td>52.9</td><td>PZD / PLC control</td><td>0</td><td>Closed</td></tr> <tr><td>52.A</td><td>Maximum frequency reached</td><td>0</td><td>Closed</td></tr> <tr><td>52.B</td><td>Alarm: Motor current limit</td><td>1</td><td>Closed</td></tr> <tr><td>52.C</td><td>Motor holding brake active</td><td>0</td><td>Closed</td></tr> <tr><td>52.D</td><td>Motor overload</td><td>1</td><td>Closed</td></tr> <tr><td>52.E</td><td>Motor dir. of rotation, clockwise</td><td>0</td><td>Closed</td></tr> <tr><td>52.F</td><td>Frequency inverter overload</td><td>1</td><td>Closed</td></tr> <tr><td>53.0</td><td>DC brake active</td><td>0</td><td>Closed</td></tr> <tr><td>53.1</td><td>Actual freq. f_act &gt; P2167 (f_off)</td><td>0</td><td>Closed</td></tr> <tr><td>:</td><td></td><td></td><td></td></tr> <tr><td>:</td><td></td><td></td><td></td></tr> </table>	52.0	Ready to power-up	0	Closed	52.1	Ready	0	Closed	52.2	Drive operational	0	Closed	52.3	Fault present	0	Closed	52.4	OFF2 active (present)	1	Closed	52.5	OFF3 active (present)	1	Closed	52.6	Power-on inhibit active (present)	0	Closed	52.7	Alarm active (present)	0	Closed	52.8	Deviation, setpoint/actual value	1	Closed	52.9	PZD / PLC control	0	Closed	52.A	Maximum frequency reached	0	Closed	52.B	Alarm: Motor current limit	1	Closed	52.C	Motor holding brake active	0	Closed	52.D	Motor overload	1	Closed	52.E	Motor dir. of rotation, clockwise	0	Closed	52.F	Frequency inverter overload	1	Closed	53.0	DC brake active	0	Closed	53.1	Actual freq. f_act > P2167 (f_off)	0	Closed	:				:			
52.0	Ready to power-up	0	Closed																																																																														
52.1	Ready	0	Closed																																																																														
52.2	Drive operational	0	Closed																																																																														
52.3	Fault present	0	Closed																																																																														
52.4	OFF2 active (present)	1	Closed																																																																														
52.5	OFF3 active (present)	1	Closed																																																																														
52.6	Power-on inhibit active (present)	0	Closed																																																																														
52.7	Alarm active (present)	0	Closed																																																																														
52.8	Deviation, setpoint/actual value	1	Closed																																																																														
52.9	PZD / PLC control	0	Closed																																																																														
52.A	Maximum frequency reached	0	Closed																																																																														
52.B	Alarm: Motor current limit	1	Closed																																																																														
52.C	Motor holding brake active	0	Closed																																																																														
52.D	Motor overload	1	Closed																																																																														
52.E	Motor dir. of rotation, clockwise	0	Closed																																																																														
52.F	Frequency inverter overload	1	Closed																																																																														
53.0	DC brake active	0	Closed																																																																														
53.1	Actual freq. f_act > P2167 (f_off)	0	Closed																																																																														
:																																																																																	
:																																																																																	
<p><b>Inverting digital outputs</b> <span style="float: right; background-color: yellow;">0</span></p> <p>This parameter allows the signals to be output to be inverted.</p>	<p><b>DOUT channel</b></p>																																																																																
<p><b>Holding brake release delay</b> (entered in s) <span style="float: right; background-color: yellow;">1.0 s</span></p> <p>Defines the time interval during which the frequency inverter runs with the min. frequency p1080 after magnetizing, before the ramp-up starts.</p> <p><math>P1216 \geq</math> brake opening time + relay opening time</p>	<p><b>Holding time after ramp-down</b> (entered in s) <span style="float: right; background-color: yellow;">1.0 s</span></p> <p>Defines time for which inverter runs at minimum frequency (p1080) after ramping down.</p> <p><math>P1217 \geq</math> brake closing time + relay closing time</p>																																																																																

www.ElectronicParts.com

### Braking functions

Priorities are assigned to the various braking functions. For instance, if a DC brake or a compound brake is activated, then this has a higher priority than the dynamic brake (resistance-type braking).



### DC-Bremse

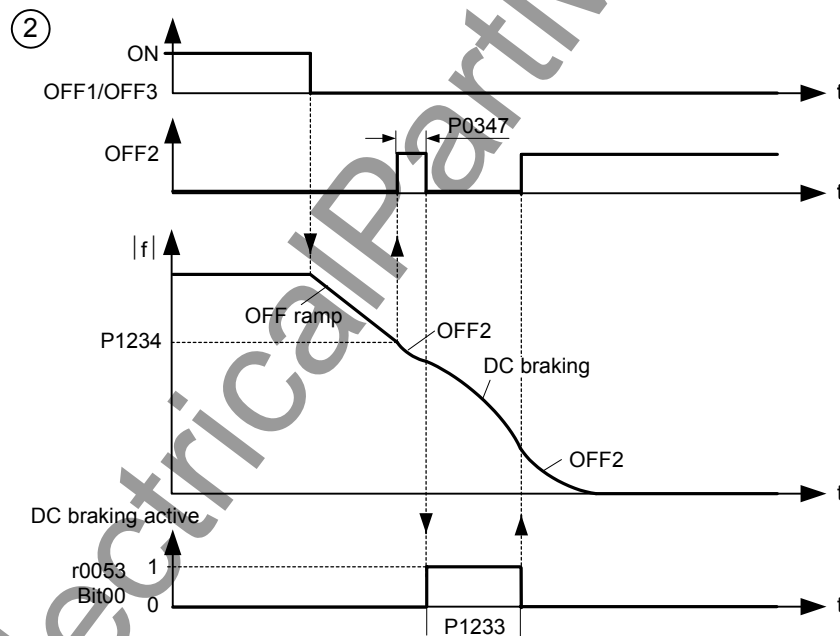
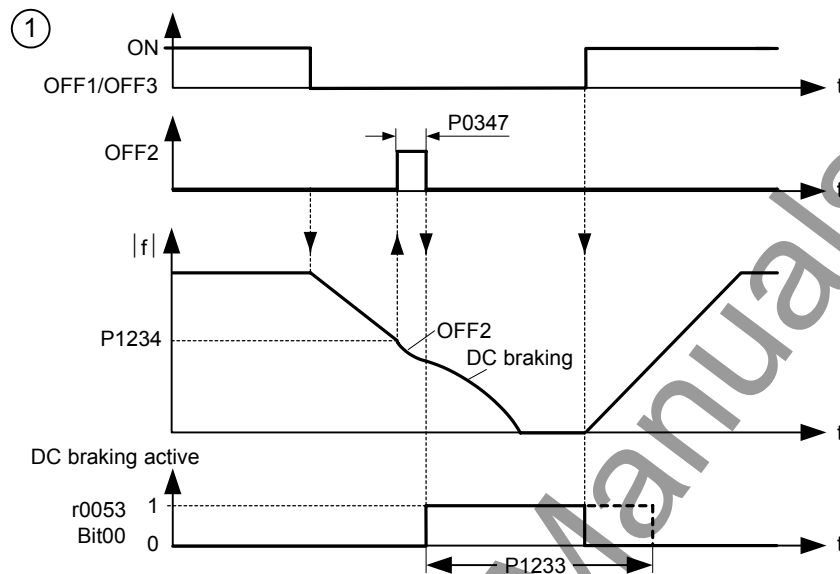
**BI: Enabling the DC brake**  
 This enables DC braking using a signal that was used from an external source. The function remains active as long as the external input signal is active. DC braking causes the motor to quickly stop by injecting a DC current

Note: DC brake can be applied in drive states r0002 = 1, 4, 5

**DC braking current** (entered in %) 100 %  
 Defines level of DC current in [%] relative to rated motor current (P0305).

P1233 =...

**Duration of DC braking** (entered in s) 0 s  
 Defines duration for which DC injection braking is to be active following an OFF1 or OFF3 command.



P1234 =...

**DC braking start frequency** (entered in Hz) 650 Hz  
 Sets the start frequency for the DC brake.

www.ElectricalPartManuals.com

**Compound braking**

P1236 = ...

**Compound braking current** (entered in %) 0 %  
 Defines DC level superimposed on AC waveform after exceeding DC-link voltage threshold of compound braking. The value is entered in [%] relative to rated motor current (P0305). (see also Vdc controller ").

If P1254 = 0 :

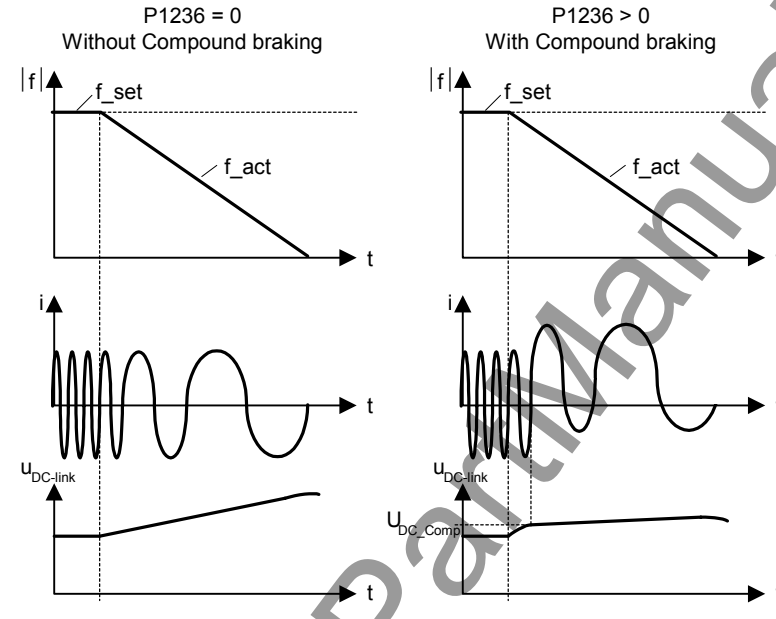
Compound braking switch-on level

$$U_{DC\_Comp} = 1.13 \cdot \sqrt{2} \cdot V_{mains} = 1.13 \cdot \sqrt{2} \cdot P0210$$

otherwise :

Compound braking switch-on level

$$U_{DC\_Comp} = 0.98 \cdot r1242$$



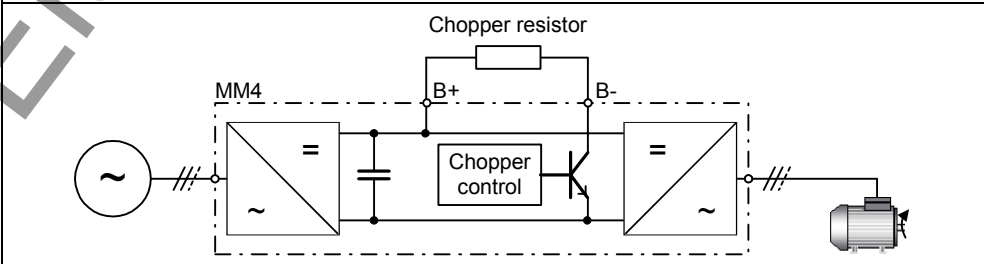
**Dynamic braking**

P1237 = ...

**Dynamic braking** 0  
 Dynamic braking is activated using parameter P1237 – the nominal (rated) duty cycle as well as the switch-in duration of the braking resistor are also defined.

- 0 Inhibited
- 1 Load duty cycle 5 %
- 2 Load duty cycle 10 %
- 3 Load duty cycle 20 %
- 4 Load duty cycle 50 %
- 5 Load duty cycle 100 %

Using the dynamic brake, the regenerative feedback energy is transferred to the external braking resistor using the chopper control (braking chopper); it is converted into thermal energy (heat) in this resistor. This dynamic braking allows the drive to be braked in a controlled fashion. This function is not available for sizes FX and GX.

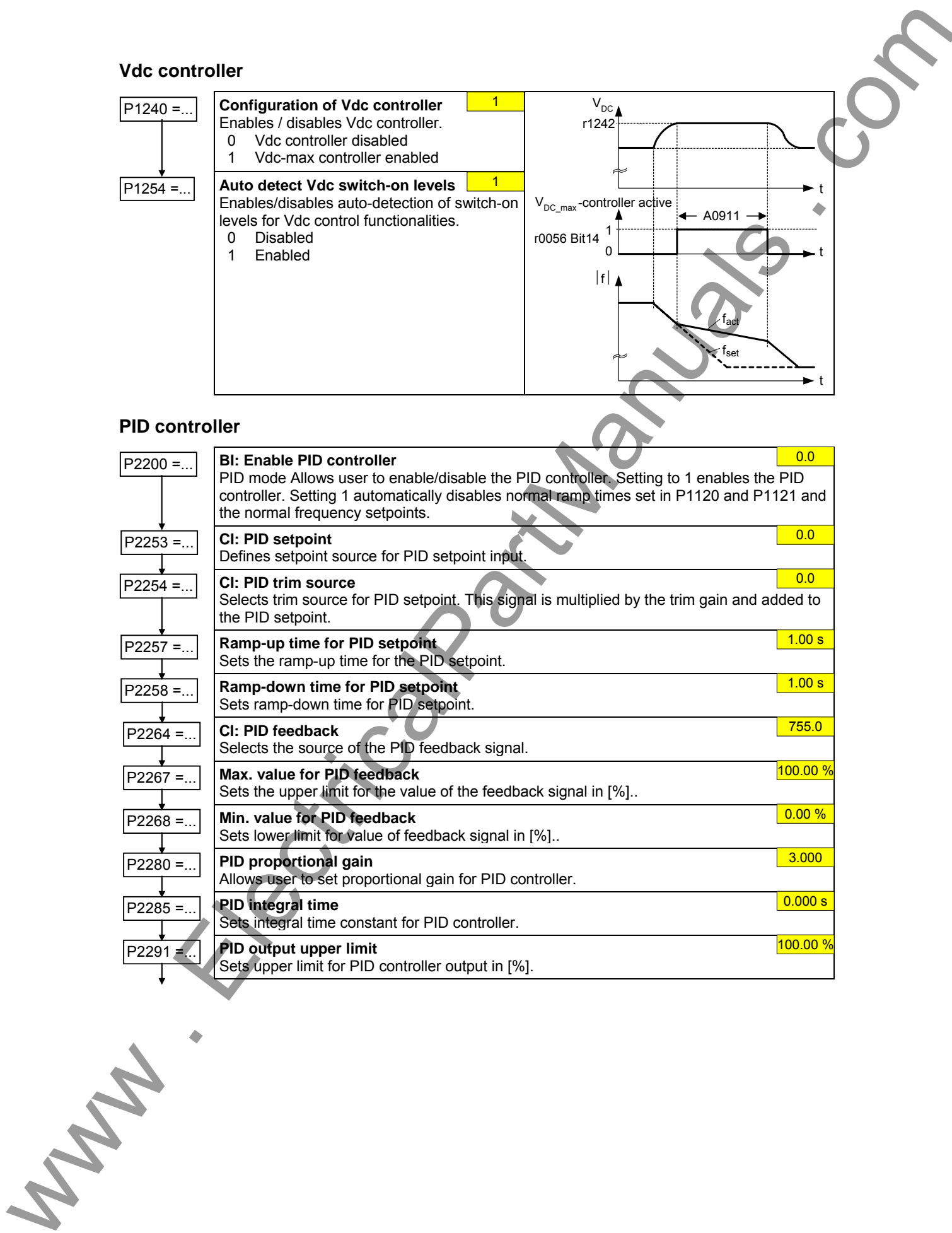


**Vdc controller**

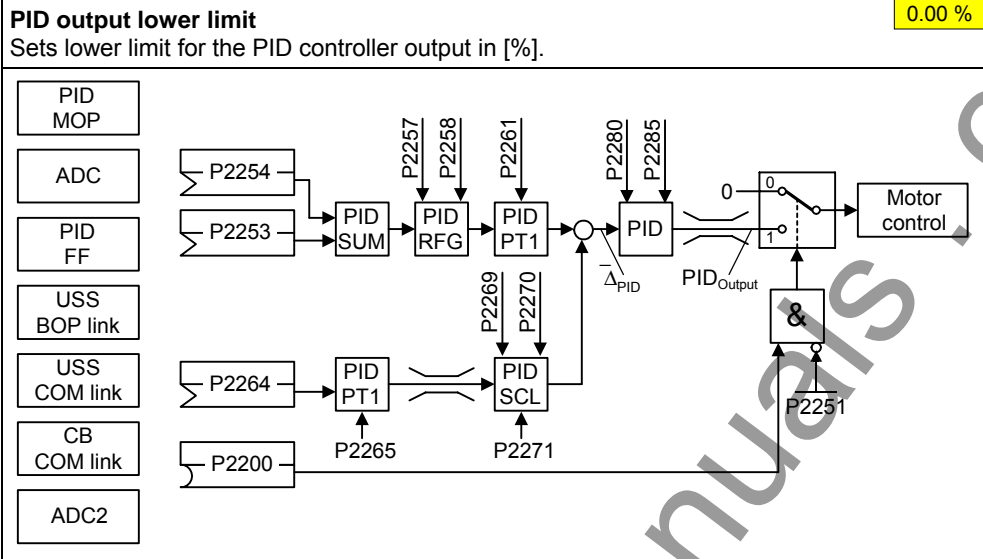
<p>P1240 = ...</p> <p>↓</p> <p>P1254 = ...</p>	<p><b>Configuration of Vdc controller</b> <span style="float: right;">1</span></p> <p>Enables / disables Vdc controller.</p> <p>0 Vdc controller disabled</p> <p>1 Vdc-max controller enabled</p> <hr/> <p><b>Auto detect Vdc switch-on levels</b> <span style="float: right;">1</span></p> <p>Enables/disables auto-detection of switch-on levels for Vdc control functionalities.</p> <p>0 Disabled</p> <p>1 Enabled</p>	
--	--	--

**PID controller**

<p>P2200 = ...</p> <p>↓</p> <p>P2253 = ...</p> <p>↓</p> <p>P2254 = ...</p> <p>↓</p> <p>P2257 = ...</p> <p>↓</p> <p>P2258 = ...</p> <p>↓</p> <p>P2264 = ...</p> <p>↓</p> <p>P2267 = ...</p> <p>↓</p> <p>P2268 = ...</p> <p>↓</p> <p>P2280 = ...</p> <p>↓</p> <p>P2285 = ...</p> <p>↓</p> <p>P2291 = ...</p> <p>↓</p>	<p><b>BI: Enable PID controller</b> <span style="float: right;">0.0</span></p> <p>PID mode Allows user to enable/disable the PID controller. Setting to 1 enables the PID controller. Setting 1 automatically disables normal ramp times set in P1120 and P1121 and the normal frequency setpoints.</p> <hr/> <p><b>CI: PID setpoint</b> <span style="float: right;">0.0</span></p> <p>Defines setpoint source for PID setpoint input.</p> <hr/> <p><b>CI: PID trim source</b> <span style="float: right;">0.0</span></p> <p>Selects trim source for PID setpoint. This signal is multiplied by the trim gain and added to the PID setpoint.</p> <hr/> <p><b>Ramp-up time for PID setpoint</b> <span style="float: right;">1.00 s</span></p> <p>Sets the ramp-up time for the PID setpoint.</p> <hr/> <p><b>Ramp-down time for PID setpoint</b> <span style="float: right;">1.00 s</span></p> <p>Sets ramp-down time for PID setpoint.</p> <hr/> <p><b>CI: PID feedback</b> <span style="float: right;">755.0</span></p> <p>Selects the source of the PID feedback signal.</p> <hr/> <p><b>Max. value for PID feedback</b> <span style="float: right;">100.00 %</span></p> <p>Sets the upper limit for the value of the feedback signal in [%]..</p> <hr/> <p><b>Min. value for PID feedback</b> <span style="float: right;">0.00 %</span></p> <p>Sets lower limit for value of feedback signal in [%]..</p> <hr/> <p><b>PID proportional gain</b> <span style="float: right;">3.000</span></p> <p>Allows user to set proportional gain for PID controller.</p> <hr/> <p><b>PID integral time</b> <span style="float: right;">0.000 s</span></p> <p>Sets integral time constant for PID controller.</p> <hr/> <p><b>PID output upper limit</b> <span style="float: right;">100.00 %</span></p> <p>Sets upper limit for PID controller output in [%].</p>
---	--



P2292 = ...



**Example:**

Parameter	Parameter text	Example
P2200	BI: Enable PID controller	P2200 = 1.0 PID controller active
P2253	CI: PID setpoint	P2253 = 2224 PID-FF1
P2264	CI: PID feedback	P2264 = 755 ADC
P2267	Max. PID feedback	P2267 Adapt to the application
P2268	Min. PID feedback	P2268 Adapt to the application
P2280	PID proportional gain	P2280 Determined by optimizing
P2285	PID integral time	P2285 Determined by optimizing
P2291	PID output upper limit	P2291 Adapt to the application
P2292	PID output lower limit	P2292 Adapt to the application



### 3.5.7.19 Command and drive data set

P0810 =...

0

**Command data set CDS bit 0 (local / remote)**  
 Selects the command source in which bit 0 should be read-out to select a command data set (CDS).

**Selecting CDS**

The currently active command data set (CDS) is displayed using parameter r0050:

	Select CDS		Active CDS
	r0055 bit15	r0054 bit15	r0050
1. CDS	0	0	0
2. CDS	0	1	1
3. CDS	1	0	2
3. CDS	1	1	2

**Most frequent settings:**

- 722.0 = Digital input 1 (P0701 must be set to 99, BICO)
- 722.1 = Digital input 2 (P0702 must be set to 99, BICO)
- 722.2 = Digital input 3 (P0703 must be set to 99, BICO)
- 722.3 = Digital input 4 (P0704 must be set to 99, BICO)
- 722.4 = Digital input 5 (P0705 must be set to 99, BICO)
- 722.5 = Digital input 6 (P0706 must be set to 99, BICO)
- 722.6 = Digital input 7 (via analog input 1, P0707 must be set to 99)
- 722.7 = Digital input 8 (via analog input 2, P0708 must be set to 99)

**Example for CDS changeover:**  
 CDS1: Command source via terminals and setpoint source via analog input (ADC)  
 CDS2: Command source via BOP and setpoint source via MOP  
 CDS changeover is realized using digital input 4 (DIN 4)

**Steps:**

1. Carry-out commissioning for CDS1 (P0700[0] = 2 and P1000[0] = 2)
2. Connect P0810 (P0811 if required) to the CDS changeover source (P0704[0] = 99, P0810 = 722.3)
3. Copy from CDS1 to CDS2 (P0809[0] = 0, P0809[1] = 1, P0809[2] = 2)
4. Adapt CDS2 parameters (P0700[1] = 1 and P1000[1] = 1)

P0820 = ...

0

**Drive data set (DDS) bit 0**  
Selects the command source from which bit 0 should be read-out to select a drive data set.

The currently active drive data set (DDS) is displayed using parameter r0051[1]:

	Select DDS			Active DDS
	r0055 bit05	r0054 bit04	r0051 [0]	r0051 [1]
1. DDS	0	0	0	0
2. DDS	0	1	1	1
3. DDS	1	0	2	2
3. DDS	1	1	2	2

**Most frequent settings:**  
 722.0 = Digital input 1 (P0701 must be set to 99, BICO)  
 722.1 = Digital input 2 (P0702 must be set to 99, BICO)  
 722.2 = Digital input 3 (P0703 must be set to 99, BICO)  
 722.3 = Digital input 4 (P0704 must be set to 99, BICO)  
 722.4 = Digital input 5 (P0705 must be set to 99, BICO)  
 722.5 = Digital input 6 (P0706 must be set to 99, BICO)  
 722.6 = Digital input 7 (via analog input 1, P0707 must be set to 99)  
 722.7 = Digital input 8 (via analog input 2, P0708 must be set to 99)

**Example:**

- Commissioning steps with a motor:
  - Carry-out commissioning at DDS1.
  - Connect P0820 (P0821 if required) to the DDS changeover source (e.g. using DIN 4: P0704[0] = 99, P0820 = 722.3).
  - Copy DDS1 to DDS2 (P0819[0] = 0, P0819[1] = 1, P0819[2] = 2).
  - Adapt DDS2 parameters (e.g. ramp-up / ramp-down times P1120[1] and P1121[1]).

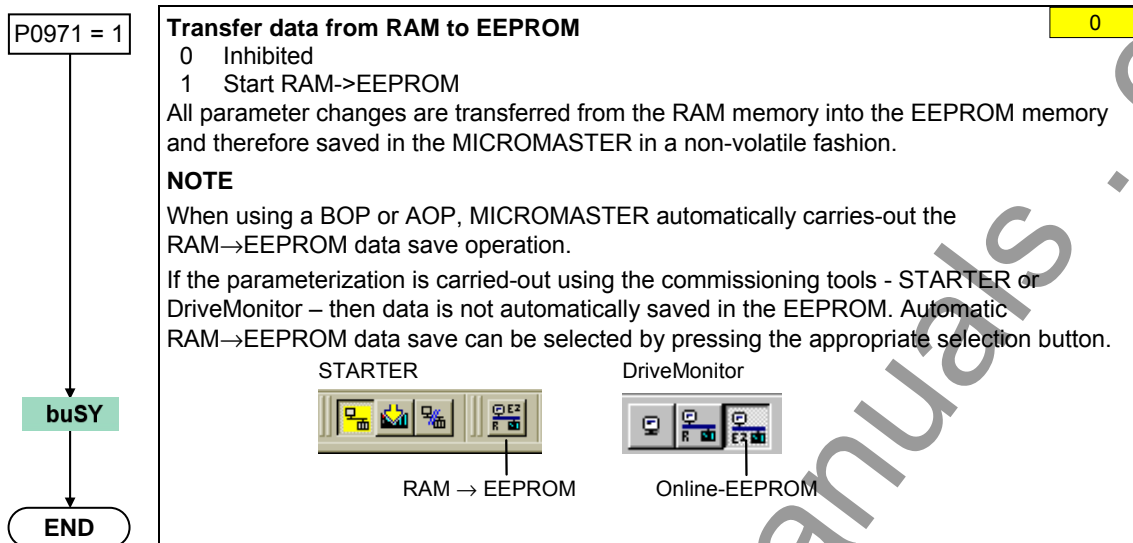
P1120			
P1121			
	[0]	[1]	[2]
	DDS1	DDS2	DDS3

- Commissioning steps with 2 motors (motor 1, motor 2):
  - Commission motor 1; adapt the remaining DDS1 parameters.
  - Connect P0820 (P0821 if required) to the DDS changeover source (e.g. via DIN 4: P0704[0] = 99, P0820 = 722.3).
  - Changeover to DDS2 (check using r0051).
  - Commission motor 2; adapt the remaining DDS2 parameters.

## 3.5.7.20 Diagnostic parameters

r0035	<b>CO: Motor temperature</b> Displays the measured motor temperature in °C.
r0036	<b>CO: Frequency inverter utilization</b> Displays the frequency inverter utilization as a % referred to the overload. In so doing, the value is calculated using the $I^2t$ model. The $I^2t$ actual value relative to the maximum possible $I^2t$ value provides the level of utilization.
r0052	<b>CO/BO: Act. status word 1</b> Displays the first active status word (ZSW) of the frequency inverter (bit format) and can be used to diagnose the inverter status.
r0054	<b>CO/BO: Control word 1</b> Displays the first control word (STW) of the frequency inverter and can be used to display the active commands.
r0063	<b>CO: Actual frequency</b> Displays the actual frequency in Hz.  <b>Frequency actual values:</b> <p>The diagram illustrates the frequency feedback loop. It starts with a switch that selects between the SLVC (observer model) and the Encoder. The SLVC path is controlled by parameter P1300 (bits 20, 22) and outputs to parameter P0400 (bits 1, 2). The Encoder path is controlled by parameter P0400 (bits 1, 2) and outputs to parameter r0061. The selected path is multiplied by 60 (parameter r0313) to produce the frequency actual value (r0063). The frequency actual value is then smoothed by a 160 ms filter to produce the smoothed frequency actual value (r0021). The smoothed frequency actual value is multiplied by 60 (parameter r0313) to produce the smoothed speed actual value (r0022). The encoder feedback path is multiplied by 60 * P0400 to produce the frequency actual value from the encoder (r0061). The parameter P1300 = 21,23 and P0400 = 0 --&gt; F0090.</p>
r1079	<b>CO: Selected frequency setpoint</b> Displays the selected frequency setpoint. The following frequency setpoints are displayed: r1078 total setpoint (HSW + ZUSW) P1058 JOG frequency, clockwise P1059 JOG frequency, counter-clockwise.
r1114	<b>CO: Freq. setpoint after dir. ctrl.</b> Displays the setpoint (reference) frequency in Hz after the function block to reverse the direction of rotation.
r1170	<b>CO: Frequency setpoint after RFG</b> Displays the total frequency setpoint (reference value) in Hz after the ramp-function generator.

### 3.5.7.21 End of commissioning



#### NOTE

If P0971 is used to start data save from the RAM to EEPROM, then after the data has been transferred, the communications memory is re-initialized. This means that communications via USS as well as also via the CB board are interrupted for the time it takes to reset:

- The connected PLC (e.g. SIMATIC S7) goes into stop
- The STARTER start-up program buffers the communications failure
- For the DriveMonitor start-up program, "NC" (not connected) or "drive busy" is displayed.
- The "busy" text is displayed at the BOP operator panel

After reset has been completed, for the start-up programs STARTER and DriveMonitor and the BOP operator panel, communications are automatically re-established.

### 3.5.8 Series commissioning

The parameter set can be read-out (upread) from the drive converter via the serial interface and saved on the hard disk / floppy disk or in a non-volatile memory (e.g. EEPROM) using the following

- PC Tools (e.g. STARTER, DriveMonitor) or the
- Operator panel AOP

(please refer to Fig. 3-28).

The interfaces of the drive inverter with USS protocol and the fieldbus interfaces (e.g. PROFIBUS) which can be used to transfer parameters, can be used as serial interface.

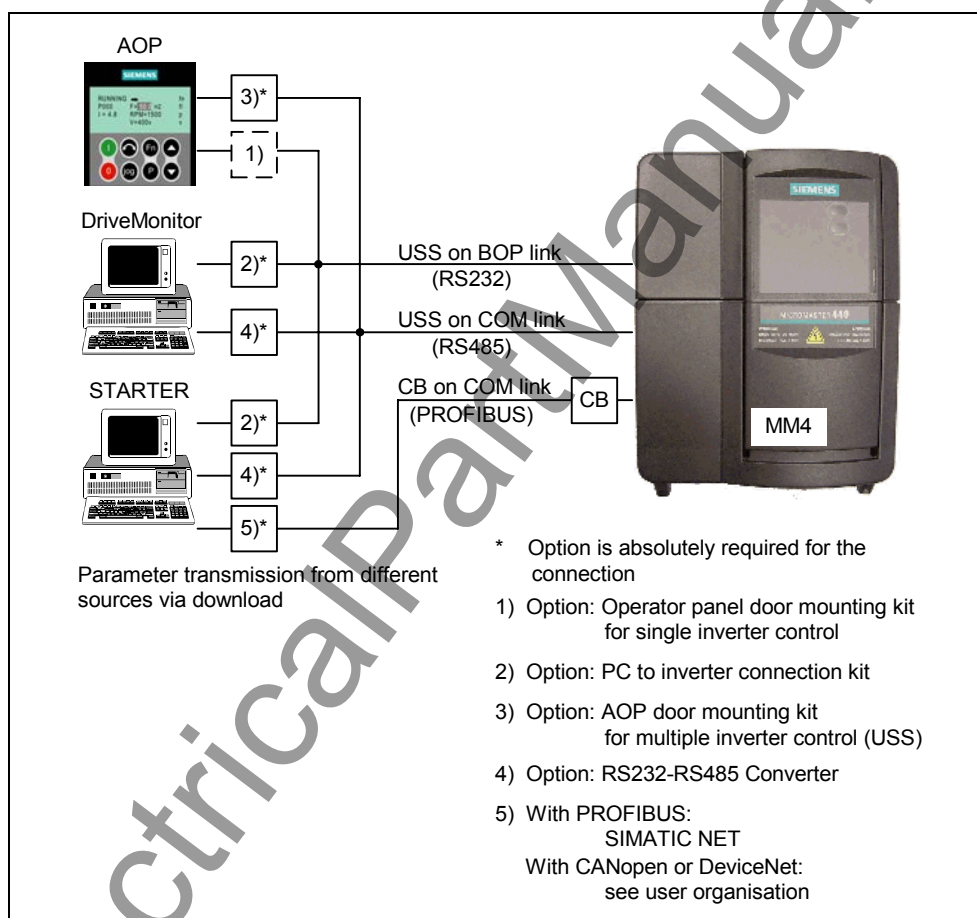


Fig. 3-28 Upread / download using AOP and PC Tools

If there is already an appropriate parameter set for the drive, which, for example, was created by either upreading or by programming offline, then this can be downloaded into the drive inverter. This means that it is possible to transfer the parameter set from drive inverter A to drive inverter B which, for identical applications (e.g. series machines, group drives) allows data to be copied and therefore in turn fast commissioning.




---

**WARNING**

- For series commissioning, all of the communication interfaces as well as also the digital and analog interfaces are re-initialized. This results in a brief communications failure or causes the digital outputs to switch.
  - Potentially hazardous loads must be carefully secured before starting a series commissioning.
  - Potentially hazardous loads can be secured as follows before starting series commissioning:
    - ◆ Lower the load to the floor, or
    - ◆ Clamp the load using the motor holding brake  
(Caution: During series commissioning, MICROMASTER must be prevented from controlling the motor holding brake).
  - If the motor holding brake (refer to Section 3.14) is controlled by the MICROMASTER, then series commissioning may not be carried-out for potentially hazardous loads (e.g. suspended loads for crane applications).
- 

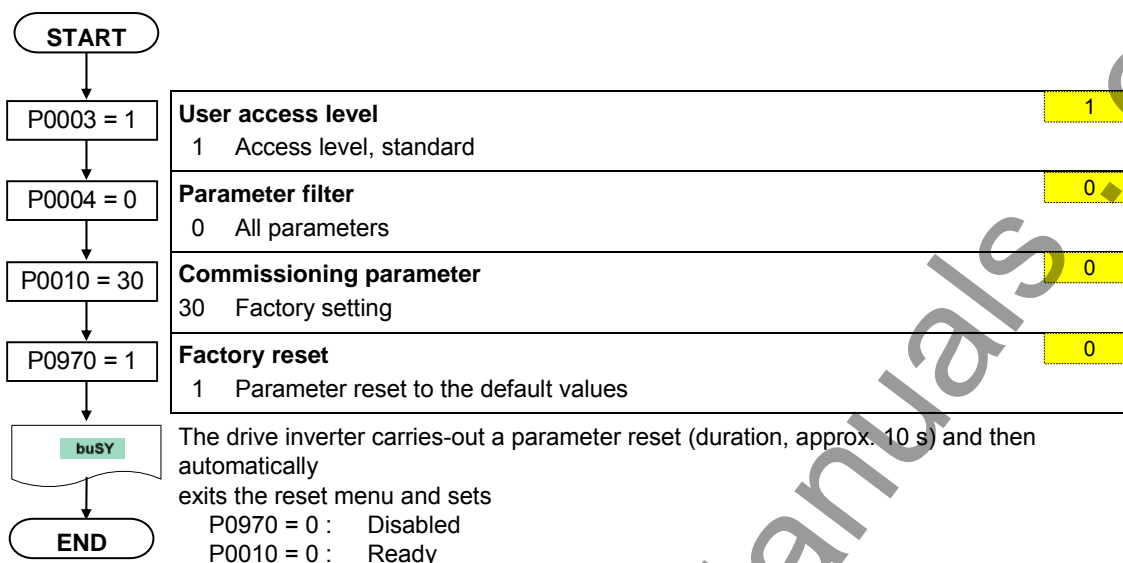
### 3.5.9 Parameter reset to the factory setting

The factory setting is a defined initial state of all of the drive inverter parameters. The drive inverters are shipped from the factory in this state. The drive inverters have the following default settings:

- Control via the digital inputs
  - a) ON/OFF via DIN1
  - b) Direction of rotation reversal via DIN2
  - c) Fault acknowledgement via DIN3
- Setpoint input via analog input 1
- Signal output via the digital outputs
  - a) Fault active via DOUT 1
  - b) Warning active via DOUT 2
- Actual frequency via the analog output
- The basic V/f characteristic is the control mode (P1300 = 0)
- Induction motor (P0300 = 1)

When appropriately connected-up and with the appropriate motor – drive inverter combination, MICROMASTER drive inverters are ready to run when shipped from the factory without requiring any additional parameterization.

You can re-establish the initial state at any time by carrying-out a parameter reset to the factory setting. This undoes all of the parameter changes which were made since the drive inverter was supplied. This value is designated as "Def" in the parameter list.

**Reset to the factory setting****NOTE**

When resetting the parameters to the factory setting, the communications memory is re-initialized. This means that communications via USS as well as also via the CB board are interrupted for the time it takes to make the reset:

- The connected PLC (e.g. SIMATIC S7) goes into stop
- The STARTER start-up program buffers the communications failure
- For the DriveMonitor start-up program, "NC" (not connected) or "drive busy" is displayed.
- The "busy" text is displayed at the BOP operator panel

After reset has been completed, for the start-up programs STARTER and DriveMonitor or the BOP operator panel, communications are automatically re-established.

### 3.6 Inputs / outputs

#### 3.6.1 Digital inputs (DIN)

- Number: 6 + 2  
 Parameter range: r0722 – P0725  
 Function chart number: FP2000, FP2200  
 Features:
- cycle time: 2 ms
  - switch-on threshold: 10.6 V
  - switch-out threshold: 10.6 V
  - electrical features: electrically isolated, short-circuit proof

External control signals are required for a drive converter to be able to operate autonomously. These signals can be entered via a serial interface as well as also via digital inputs (refer to Fig. 3-29). MICROMASTER has 6 digital inputs which can be expanded to a total of 8 by using the 2 analog inputs. The digital inputs, as far as their assignment, can be freely programmed to create a function. Whereby, regarding the program, it is possible to directly assign the function via parameters P0701 - P0708 or to freely program the function using BICO technology.

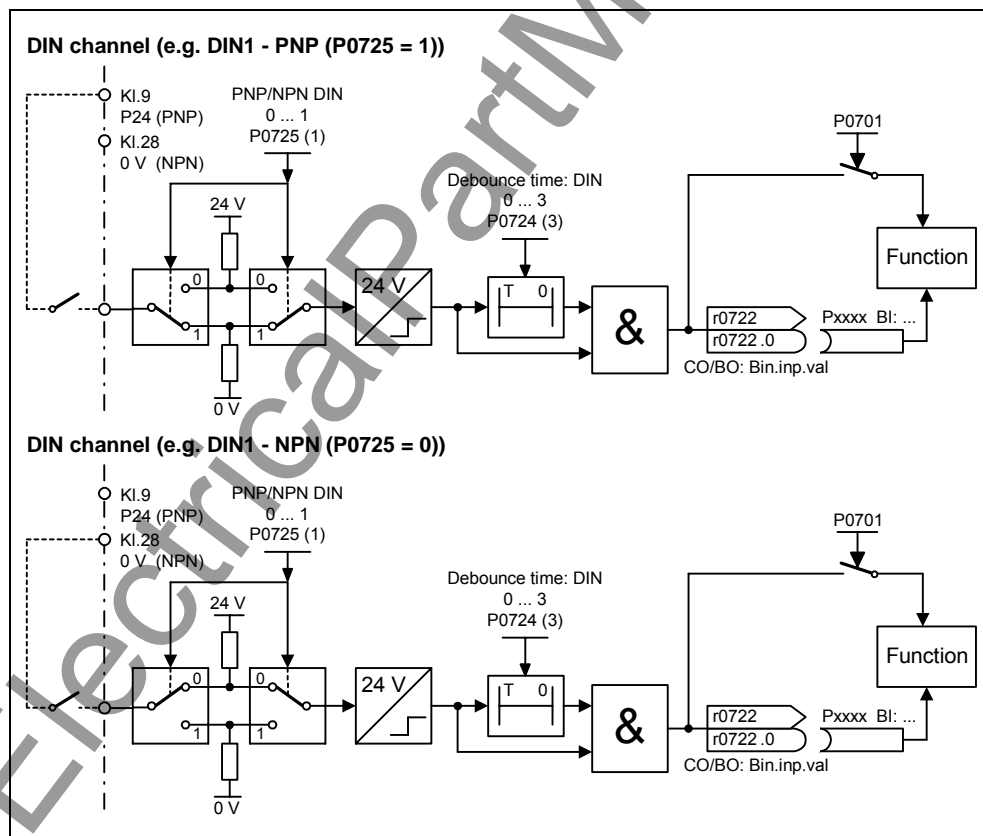


Fig. 3-29 Digital inputs

Parameter P0725 is used to define as to whether digital inputs DIN1 - DIN6 are logical "1" when appropriately connected to 0 V or 24 V. The logical states of the digital inputs can be de-bounced using P0724 and read-out using parameter r0722 (BICO monitoring parameter). Further, this parameter is used to parameterize BICO for the digital inputs (refer to BICO parameterization in the following Section).

**P0701 – P0706 (digital inputs 1–6) or P0707 – P0708 (analog inputs 1-2)**

The possible settings of the individual inputs are listed in Table 3-11.

Table 3-11 Parameters P0701 – P0706

Parameter value	Significance
0	Digital input disabled
1	ON / OFF1
2	ON+reverse / OFF1
3	OFF2 – coast to standstill
4	OFF3 – quick ramp-down
9	Fault acknowledge
10	JOG right
11	JOG left
12	Reverse
13	MOP up (increase frequency)
14	MOP down (decrease frequency)
15	Fixed setpoint (direct selection)
16	Fixed setpoint (direct selection + ON)
17	Fixed setpoint (binary-coded selection + ON)
25	Enable DC braking
29	External trip
33	Disable additional frequency setpoint
99	Enable BICO parameterization

**Example:**

An ON/OFF1 command should be realized using digital input DIN1.

P0700 = 2 Control enabled via terminal strip (digital inputs)

P0701 = 1 ON/OFF1 via digital input 1 (DIN1)

**NOTE**

If an analog input (refer to Fig. 3-33) has been configured as digital input, then the following limit values apply:

< 1.7 V DC → "0"

> 3.9 V DC → "1"

### BICO parameterization

If the setting 99 (BICO) is entered into parameters P0701 – P0708, then the BICO wiring is enabled for the appropriate digital input. The output parameter number of the function (parameter, included in the parameter text BO) should be entered into the command source (parameter which contains the code BI in the parameter text).

**Example:**

An ON/OFF1 command should be realized using digital input DIN1.

P0700 = 2	Control enabled via digital inputs
P0701 = 99	BICO enabled for DIN1
P0840 = 722.0	ON/OFF1 via DIN1

---

**NOTE**

Only experienced users should use the BICO parameterization and for applications where the possibilities provided by P0701 – P0708 are no longer adequate.

---

### 3.6.2 Digital outputs (DOUT)

- Number: 3
- Parameter range: r0730 – P0748
- Function chart number: FP2100
- Features:
  - cycle time: 1 ms

Binary states in the drive can be output via the digital outputs. As result of the fast cycle time, it is possible to control external devices and to display the state in real time. In order that higher powers can also be output, the internal signal (TTL level) is amplified using a relay (refer to Fig. 3-30).

- Relay:
- max. opening / closing time: 5 / 10 ms
  - voltage / current: 30 V DC / 5 A  
250 V AC / 2 A

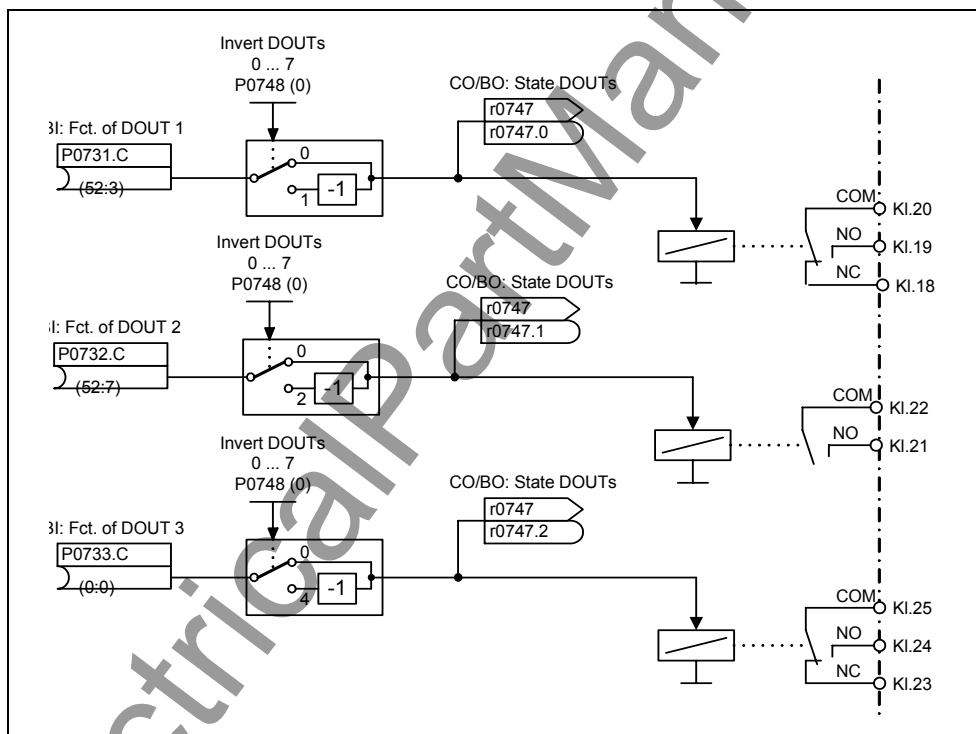


Fig. 3-30 Digital outputs

The states, which are to be output, are defined using the "BI" parameters P0731 (digital output 1), P0732 (digital output 2) and P0733 (digital output 3). For the definition, the "BO" parameter number or "CO/BO" parameter number and the bit number of the particular state should be entered into P0731 – P0733. Frequently used states including the parameter number and bit are shown in the following Table (refer to Table 3-12).

Table 3-12 Parameters P0731 – P0733 (frequently used functions / states)

Parameter value	Significance
52.0	Drive ready

52.1	Drive ready to run
52.2	Drive running
52.3	Drive fault active
52.4	OFF2 active
52.5	OFF3 active
52.6	Switch-on inhibit active
52.7	Drive warning active
52.8	Deviation, setpoint / actual value
52.9	PZD control (Process Data Control)
52.A	Maximum frequency reached
52.B	Warning: Motor current limit
52.C	Motor holding brake (MHB) active
52.D	Motor overload
52.E	Motor running direction right
52.F	Inverter overload
53.0	DC brake active
53.1	Act. frequency f_act >= P2167 (f_off)
53.2	Act. frequency f_act > P1080 (f_min)
53.3	Act. current r0027 >= P2170
53.6	Act. frequency f_act >= setpoint

**NOTE**

A complete list of all of the binary status parameters (refer to "CO/BO" parameters) can be taken from the parameter list.

### 3.6.3 Analog inputs (ADC)

Number: 2  
 Parameter range: P0750 – P0762  
 Function chart number: FP2200

Features:

- cycle time: 4 ms
- resolution: 10 bits
- accuracy: 1 % referred to 10 V / 20 mA
- electrical features: incorrect polarity protection, short-circuit proof

Analog setpoints, actual values and control signals are read-into the drive inverter using the appropriate analog inputs and are converted into digital signals / values using the ADC converter.

The setting as to whether the analog input is a voltage input (10 V) or a current input (20 mA) must be selected using the 2 switches DIP1(1,2) on the I/O board as well as also using parameter P0756 (refer to Fig. 3-31).

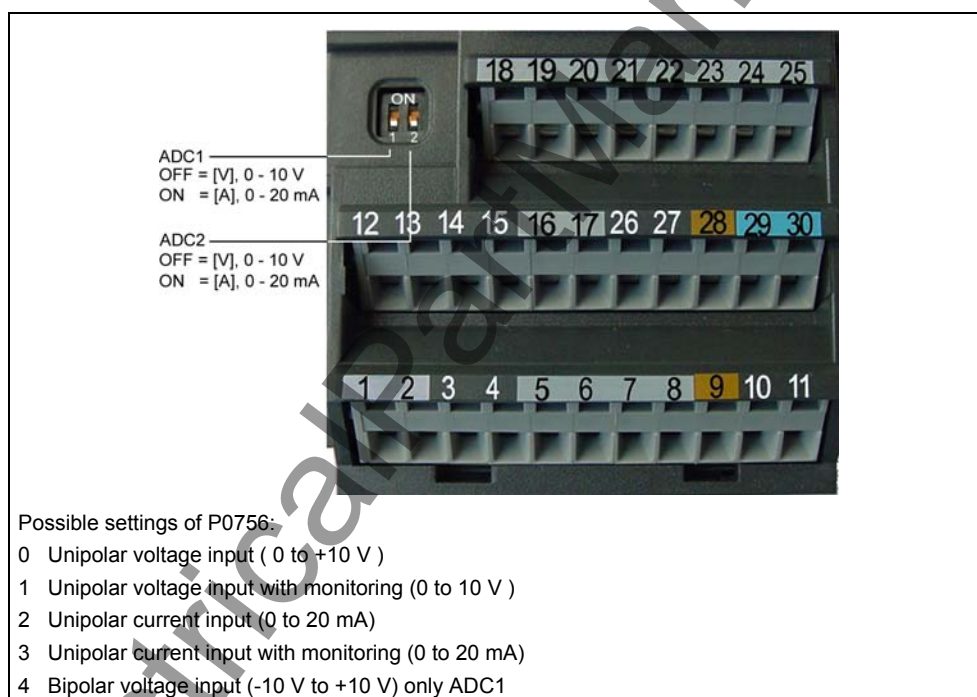


Fig. 3-31 DIP switch and P0756 for ADC current / voltage input

#### NOTE

- The setting (analog input type) of P0756 must match that of switch DIP1(1,2) on the I/O board.
- The bipolar voltage input is only possible with analog input 1 (ADC1).

Depending on the ADC type or source, the appropriate connection must be made. Using, as an example, the internal 10 V voltage source, a connection is shown as an example in the following diagram (refer to Fig. 3-32).

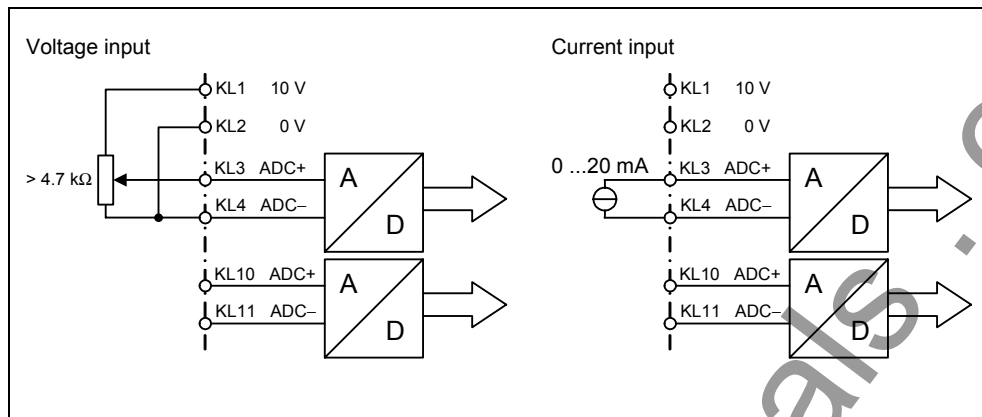


Fig. 3-32 Connection example for ADC voltage / current input

The ADC channel has several function units (filter, scaling, dead zone) (refer to Fig. 3-33).

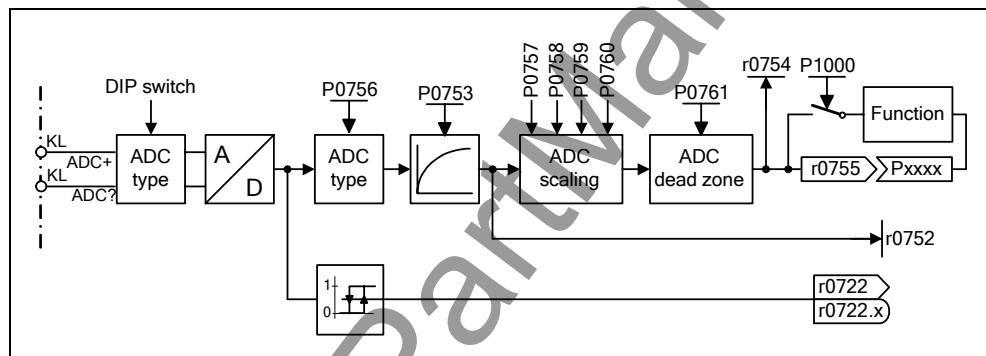


Fig. 3-33 ADC channel

**NOTE**

When the filter time constant P0753 (ADC-PT1) is increased, this smooths the ADC input signal therefore reducing the ripple. When this function is used within a control loop, this smoothing has a negative impact on the control behavior and immunity to noise (the dynamic performance deteriorates).

### 3.6.4 Analog outputs (D/A converter)

Number: 2  
 Parameter range: r0770 – P0785  
 Function chart number: FP2300  
 Features:  
 - cycle time: 4 ms  
 - resolution: 10 bit  
 - accuracy: 1 % referred to 20 mA

Setpoints, actual values and control signals inside the drive inverter are read-out via the D/A converter using these analog inputs. The digital signal is converted into an analog signal. All of the signals can be output via the D/A which contain the "CO" abbreviation in the parameter text (refer to list of all of the BICO parameters in the parameter list). Parameter P0771 defines, by assigning the parameter number, the quantity which is output as analog signal through the D/A converter channel (refer to Fig. 3-34). The smoothed output frequency is output, e.g. via the analog output, if P0771[0] = 21.

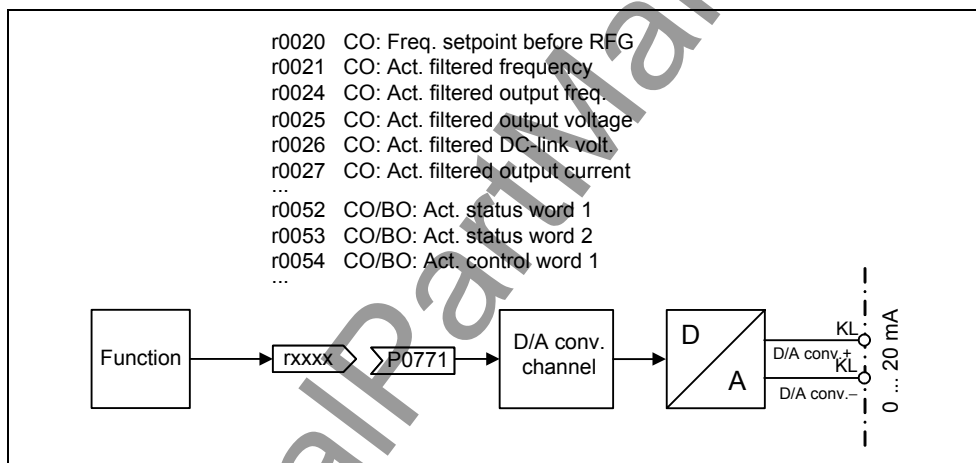


Fig. 3-34 Signal output through the D/A converter channel

In order to adapt the signal, the D/A converter channel has several function units (filter, scaling, dead zone) which can be used to modify the digital signal before conversion (refer to Fig. 3-35).

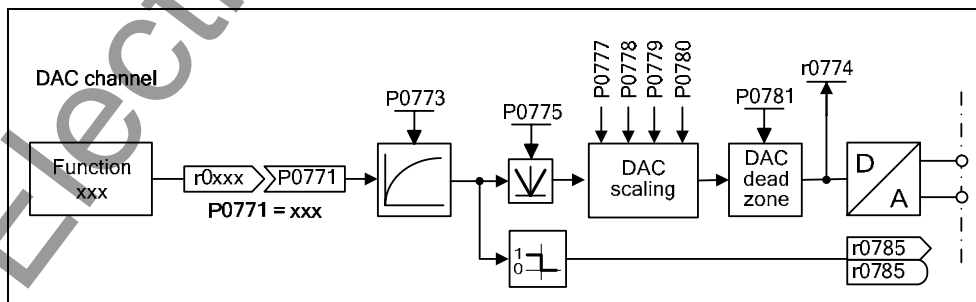


Fig. 3-35 D/A converter channel

With parameter P0775 = 1, negative values can be avoided on the input side of the DAC channel. If this parameter is activated, the absolute value is always entered in the input of the DAC scaling (the DAC characteristic is mirrored on the Y axis). If the value was originally a negative one, the corresponding bit in r0785 is set for detection.

---

**NOTE**

The analog outputs only provide current outputs (0 ... 20 mA). A 0 ... 10 V voltage signal can be generated by connecting a 500 Ohm resistor across the outputs. The voltage drop across the resistor can be read using parameter r0774 if the parameter P0776 is changed-over from current output (P0776 = 0) to voltage output (P0776 = 1). The D/A scaling parameters P0778, P0780 and the D/A converter dead zone must still be entered in mA (0 ... 20).

---

### 3.7 Communications

Parameter range:	P2009 – r2091
Function chart number:	
CB at COM link	FP2700, FP2710
USS at COM link	FP2600, FP2610
USS at BOP link	FP2500, FP2510

MICROMASTER 440 has 2 serial communication interfaces which can be simultaneously used. These interfaces are designated as follows in the following text:

- BOP link
- COM link

Different units, such as the BOP and AOP operator panels, PCs with the start-up software DriveMonitor and STARTER, interface modules for PROFIBUS DP, DeviceNet and CAN as well as programmable controls with communication processors can be connected at this interface (refer to Fig. 3-28).

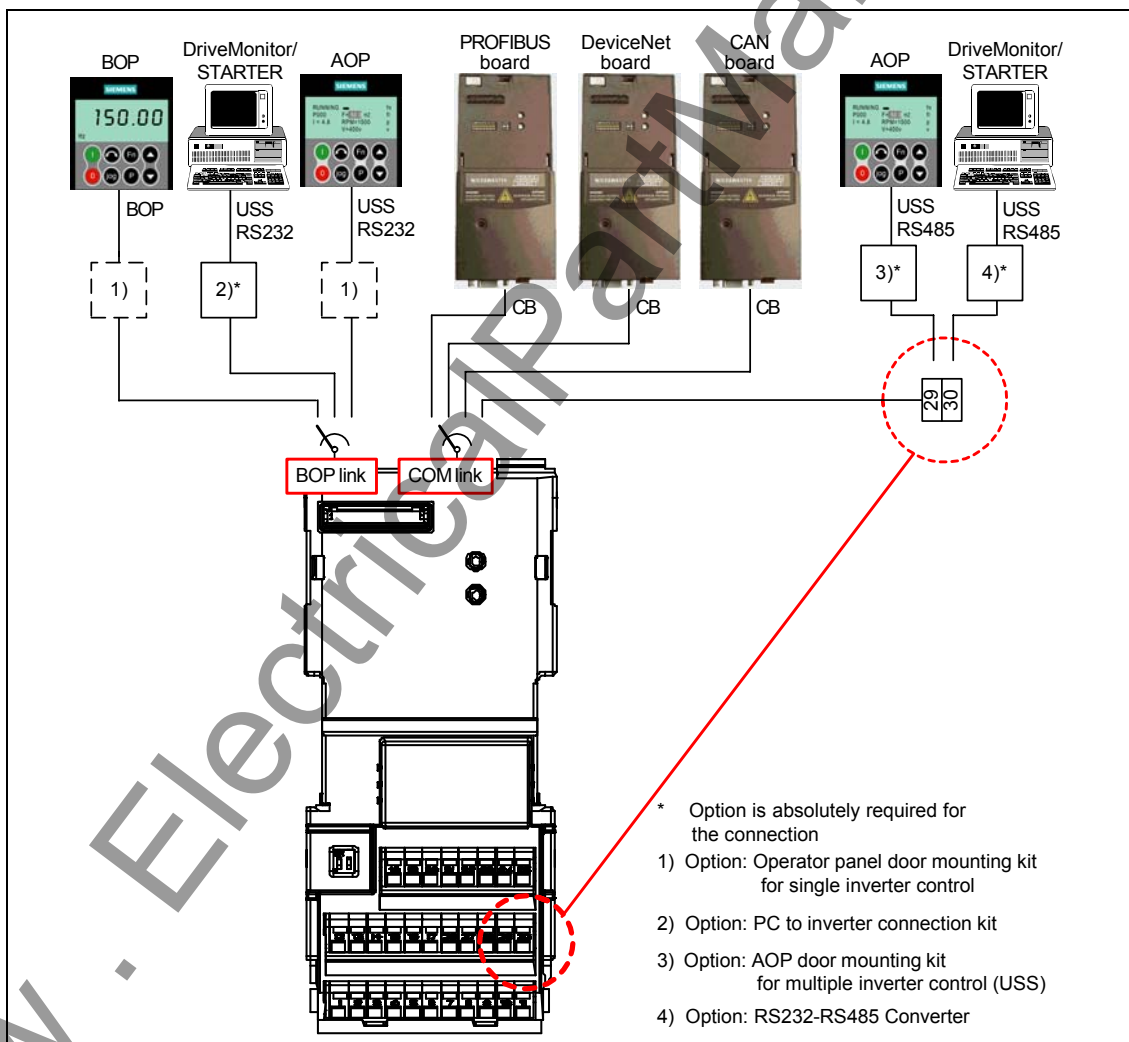


Fig. 3-36 Serial communication interfaces - BOP link and COM link

The BOP, a programming / operator unit (e.g. AOP, PC with DriveMonitor / STARTER) or a programmable control with communications processor can be connected via this BOP link. Data transfer between MICROMASTER and the programming / operator units is realized using the USS protocol via the RS232 interface (point-to-point data coupling). Communications between the BOP and MICROMASTER uses a optimized interface which takes into consideration the somewhat limited resources of the BOP. If the BOP is replaced by an USS unit (PC, AOP), then MICROMASTER automatically identifies the interface of the new unit. This is also true for the inverse replacement sequence. The BOP link interface can be adapted to the particular unit using the following parameters (refer to Table 3-13).

Table 3-13 BOP link

BOP link – interface		
BOP on BOP link		USS on BOP link
No parameter		P2009[1] P2010[1] P2011[1] P2012[1] P2013[1] P2014[1] r2015 P2016
		r2024[1] r2025[1] r2026[1] r2027[1] r2028[1] r2029[1] r2030[1] r2031[1] r2032 r2033

Communication modules (CB) such as PROFIBUS, DeviceNet, CANopen and also programming / operator units (e.g. PCs with the DriveMonitor / STARTER start-up software and AOP) as well as programmable controls with communication processor can be connected to the COM link. The plug connector allows the communication modules to be connected to MICROMASTER. On the other hand, the programming / operator units must be connected to the MICROMASTER through terminals 29/30. As for the BOP link, data is transferred between MICROMASTER and the programming / operator unit using the USS protocol. In so doing, for the COM link, the USS protocol is transferred via the bus-capable RS485 interface. Essentially the same as the BOP link, the COM link also automatically defines if a communications module is replaced with a USS unit (PC, AOP). The COM link can be adapted to the particular unit using the following parameters (refer to Table 3-14).

Table 3-14 COM link

COM link – interface			
CB on COM link		USS on COM link	
P2040	r2053	P2009[0]	r2024[0]
P2041	r2054	P2010[0]	r2025[0]
r2050	r2090	P2011[0]	r2026[0]
P2051	r2091	P2012[0]	r2027[0]
		P2013[0]	r2028[0]
		P2014[0]	r2029[0]
		r2018	r2030[0]
		P2019	r2031[0]
			r2036
			r2037

**NOTE**

- A communications (CB) module as well as a programming / operator unit can be simultaneously connected to the COM link interface via terminals 29/30 (USS). This is the reason that the communications module has priority over USS. In this case, the USS node (USS station) via the COM link is de-activated.
- Contrary to PROFIBUS, the RS485 port (terminals 29/30) is not optically isolated (not floating). When installing the system, it must be ensured that EMC faults do not result in communication failures or damage to the RS485 drivers.

**3.7.1 Universal serial interface (USS)**

Parameter range: P2009 – r2037

Significance	COM link	BOP link
USS basic setting		
USS baud rate	P2010[0]	P2010[1]
USS address	P2011[0]	P2011[1]
USS-PZD length	P2012[0]	P2012[1]
USS-PKW length	P2013[0]	P2013[1]
PZD data		
Received data	r2018[8]	r2015[8]
Received control word 1	r2036	r2032
Received control word 2	r2037	r2033
Sent data	P2019[8]	P2016[8]
Sent status word 1	r0052	r0052
Sent status word 2	r0053	r0053

Alarms: ---

Faults: F0071, F0072

Function chart number: FP2500, FP2510, FP2600, FP2610

Features:

- electrical features: Not electrically isolated      USS at the BOP link with PC-converter connecting set
- Not electrically isolated      USS at COM link (terminals 29 /30)
- cycle time (MM440): 8 ms      (process data PZD)
- Background      (parameter ID value PKW)

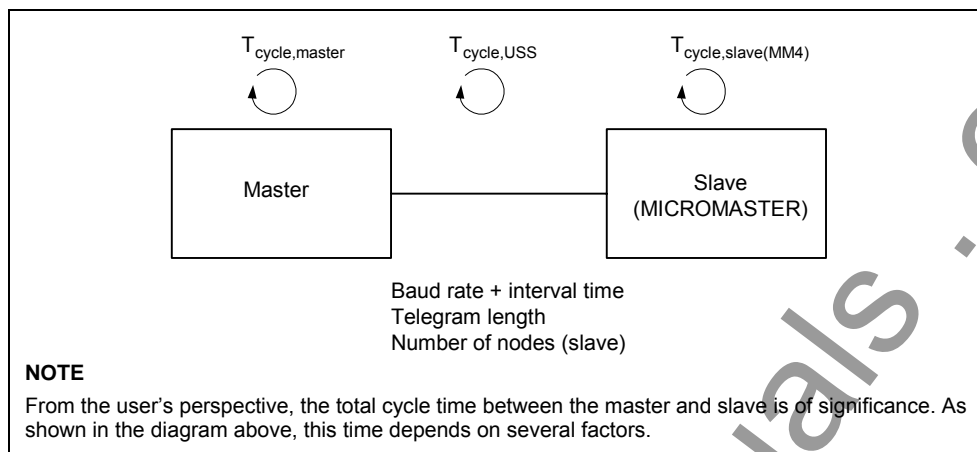


Fig. 3-37 Cycle times

Using the USS protocol, a user can establish a serial point-to-point data link and a serial bus data link between a higher-level master system and several slave systems. Master systems can be, for example, PLCs (e.g. SIMATIC S7-200) or PCs. MICROMASTER drive converters are always the slaves on the bus system.

The USS protocol allows the user to implement both automation tasks with cyclical telegram traffic (→ a fixed telegram length is necessary) as well as visualization tasks. In this case, the protocol with variable telegram length is advantageous, as texts and parameter descriptions can be transferred in one telegram without chopping up the information.

### 3.7.1.1 Protocol specification and bus structure

The USS protocol has the following significant features:

- Supports
  - ◆ a multi-point-capable link, e.g. EIA RS 485 hardware or
  - ◆ a point-to-point link, e.g. EIA RS 232
- Master-slave access technique
- Single-master system
- Maximum 32 nodes (max. 31 slaves)
- Operation with variable or fixed telegram length
- Simple, reliable telegram frames
- The same bus mode of operation as with the PROFIBUS (DIN 19245 Part 1)
- Data interface to the basic unit according to PROFILE variable-speed drives. This means that, when the USS is being used, information is transferred to the drive in the same way as with the PROFIBUS-DP.
- Can be used for start-up, service and automation
- PC-based service tools (e.g. STARTER and DriveMonitor)
- Can be easily implemented in customized systems

#### Protocol specification

The USS protocol defines an access technique according to the master-slave principle for communications via a serial bus. The point-to-point link is included as a sub-quantity.

One master and a maximum of 31 slaves can be connected to the bus. The individual slaves are selected by the master using an address character in the telegram. A slave can never transmit without first being initiated by the master so that direct information transfer between individual slaves is not possible. The master function cannot be transferred (single-master system). The following illustration shows a bus configuration using drive technology as an example.

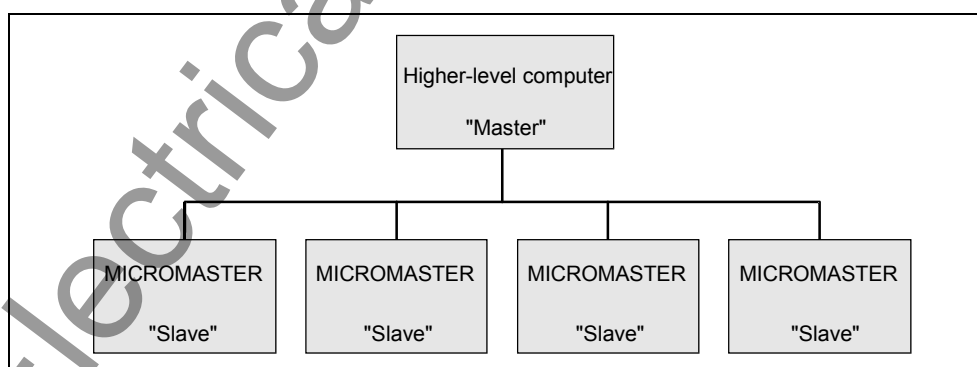


Fig. 3-38 Serial linking of MICROMASTER (slaves) with a higher-level computer (master)

The telegram has the following structure:

- Each telegram begins with the start character STX (= 02 hex), followed by the length information (LGE) and the address byte (ADR). The net characters then follow. The telegram is terminated by the BCC (Block Check Character).
- For single-word data (16 bit) in the net data block (= net character block), the high byte (first character) is always sent and then the low byte (second character).
- The same applies to double-word data: the high word is sent first followed by the low word.
- The necessary settings / parameter assignments must be made both at the master as well as at the slave and can no longer be changed in bus operation.
- The protocol does not identify tasks in the net characters. The contents of the net characters/data for the MICROMASTER drives is discussed in Section 3.7.1.2 "Structure of the net data".

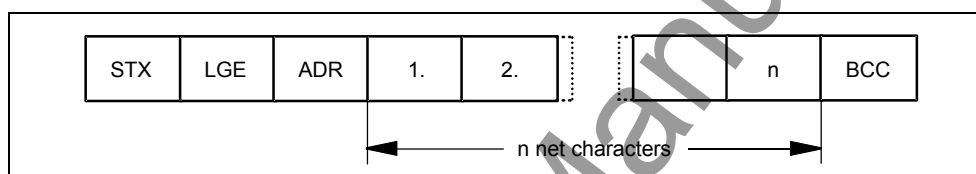


Fig. 3-39 Telegram structure

Information is coded as follows:

Abbreviation	Significance	Size	Explanation
STX	Start of text	ASCII characters	02 hex
LGE	Telegram length	1 byte	Contains the telegram length
ADR	Address	1 byte	Contains the slave address and the telegram type (binary coded)
---	Net characters	Each one byte	Net data, contents are dependent on the request
BCC	Block check character	1 byte	Data security characters

In the address byte, information other than the node number is coded:  
The individual bits in the address byte are assigned as follows:

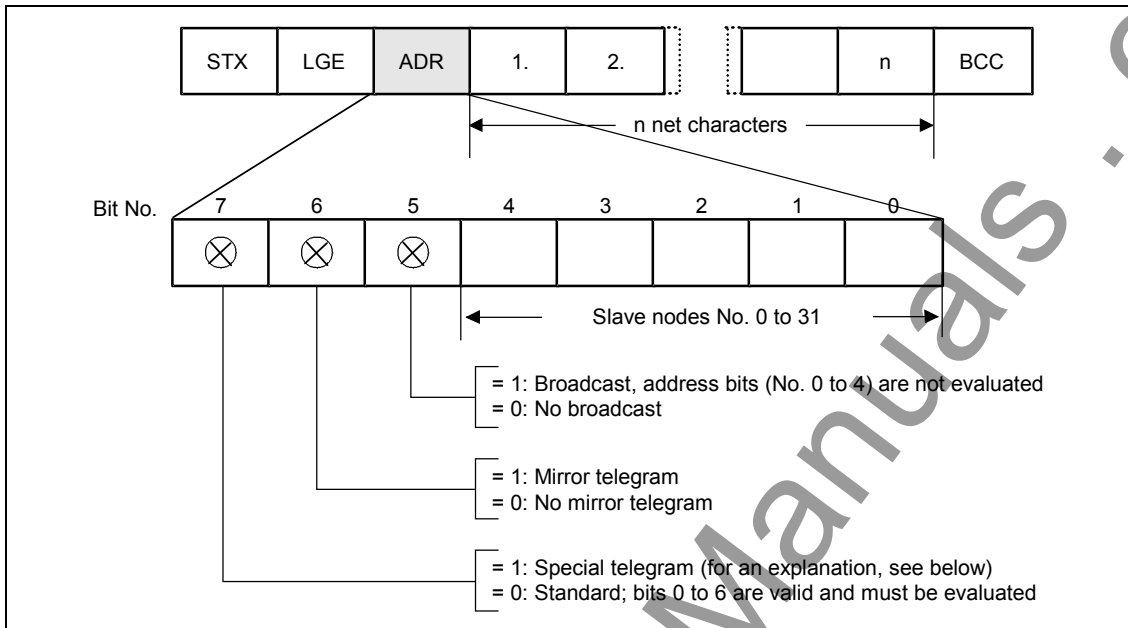


Fig. 3-40 Assignment of the address byte (ADR)

The master ensures cyclical telegram data transfer. The master addresses all of the slave nodes one after the other with a task telegram. The addressed nodes respond with a reply telegram. In accordance with the master-slave procedure, the slave, after receiving the task telegram, must send the reply telegram to the master before the master can address the next slave node.

The sequence of the addressed slave nodes can be specified, for example, by entering the node numbers (ADR) in a circulating list (polling list) in the master. If it is necessary to address several slaves in a faster cycle than the other slaves, their node number can occur several times in the circulating list. A point-to-point link can be implemented by means of the circulating list, in which case only one node is entered into the circulating list.

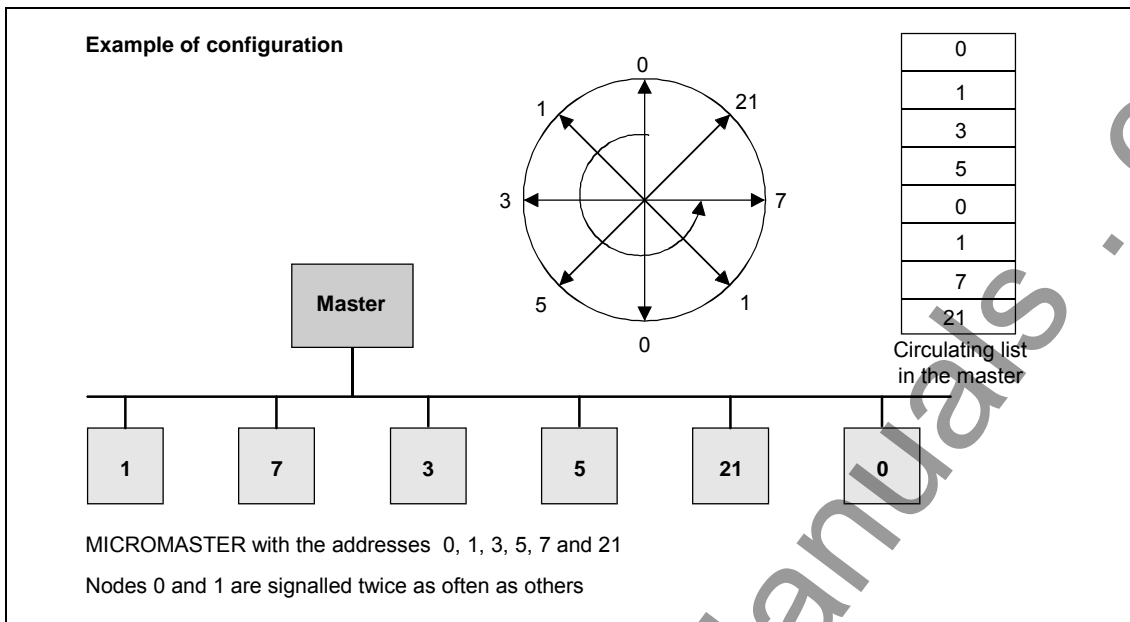


Fig. 3-41 Circulating list (Example of configuration)

The length of a cycle time is determined by the time needed for the sequential occurrence of data exchange with the individual nodes.

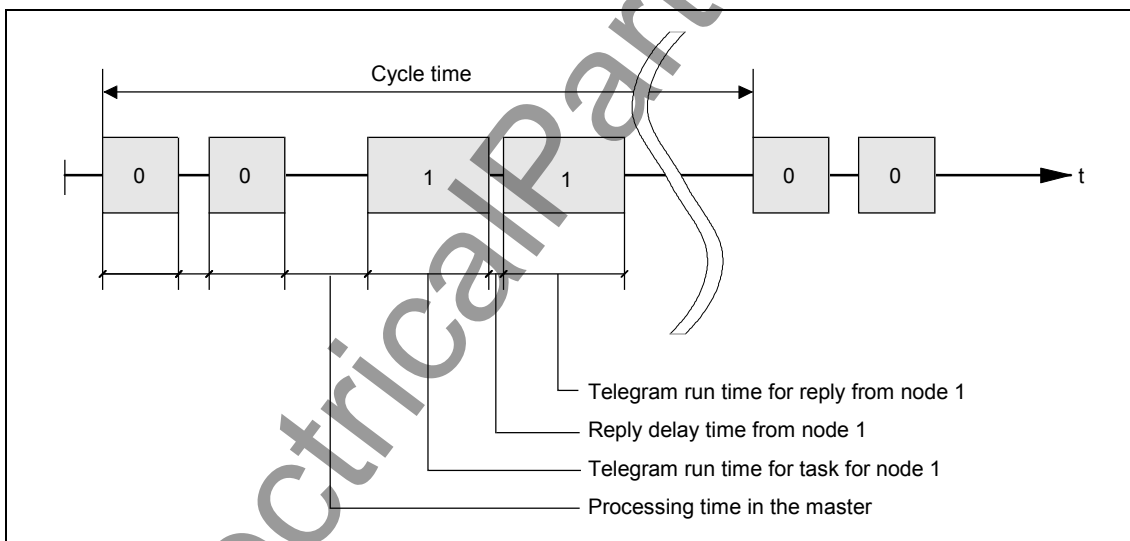


Fig. 3-42 Cycle time

Due to inconstant reply delay and processing times, the cycle time is not fixed.

The STX start character (= 02 hexadecimal) by itself is not sufficient for the slaves to clearly identify the start of a telegram because the bit combination 02/hexadecimal can also occur in the net characters. For this reason, a no-character start interval of at least 2 character run-times before the STX is specified for the master. The start interval is part of the task telegram.

Table 3-15 Minimum start intervals for various baud rates

Baud rate in bit/s	Start interval in ms
2400	9,20 ms
4800	4,60 ms
9600	2,30 ms
19200	1,15 ms
38400	0,57 ms
57600	0,38 ms
76800	0,29 ms
93750	0,24 ms
115200	0,19 ms

Only an STX with a preceding start interval identifies the valid start of a telegram. Data is always transferred in accordance with the diagram illustrated below (half-duplex mode):

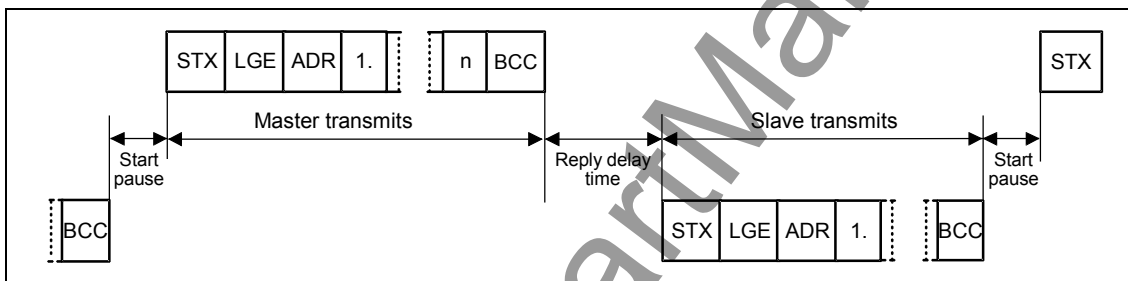


Fig. 3-43 Transmit sequence

The time interval between the last character of the task telegram (BCC) and the start of the reply telegram (STX) is known as the reply delay time. The maximum permissible reply delay time is 20 ms, but it must not be less than the start interval. If node x does not respond within the maximum permissible reply delay time, an error message is deposited in the master.

The master then sends the telegram for the next slave node.

### Bus structure

The data transfer medium and the physical bus interface are essentially determined by what the bus system is used for. The physical interface of the USS protocol is based on the "Recommended Standard RS-485". For point-to-point links, a sub-quantity of EIA RS-232 (CCITT V.24) or TTY (20 mA current loop) can be used as the physical interface.

The USS bus is based on a linear topology without branches. Both ends of the line terminate at a node. The maximum cable length (50 m) and therefore the maximum distance between the master and the last slave is limited by the characteristics of the cable, the ambient conditions and the data transfer rate [EIA Standard RS-422-A Dezember 1978, Appendix, Page 14]

- The number of nodes is limited to a maximum of 33 (1 master, 32 slaves).

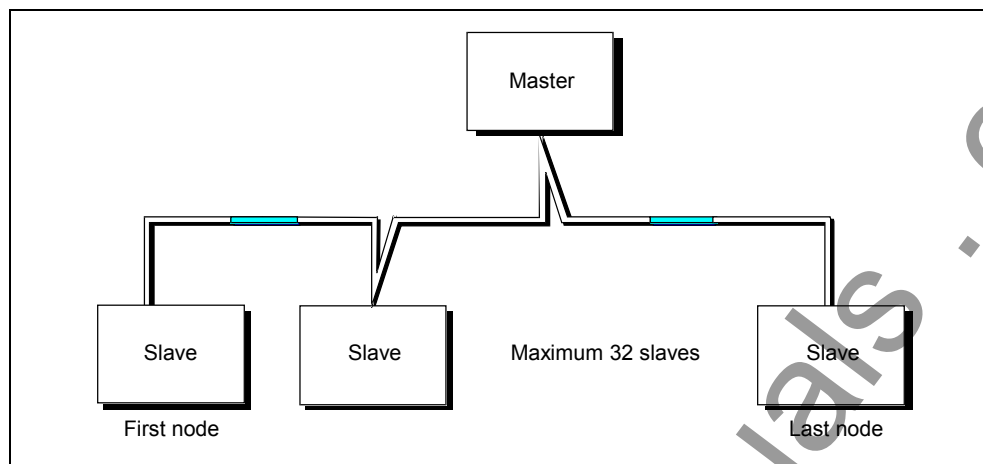


Fig. 3-44 USS bus topology

The two ends of a bus line (first node and last node) must be terminated with bus terminating networks. (refer to Section 3.7.1.3). Point-to-point connections are handled just like bus connections. One node has the master function and the other has the slave function.

Data is transferred in accordance with Standard EIA 485. RS 232 can be used for point-to-point links. Data transfer is always half-duplex – i.e. alternating between transmitting and receiving – and it must be controlled by the software. The half-duplex technique allows the same cables to be used for both data-transfer directions. This permits simple and inexpensive bus cabling, operation in environments subject to interference and a high data transfer rate.

A shielded, twisted two-wire cable is used as the bus cable.

Table 3-16 Structural data

Conductor diameter	2 x ≈ 0,5 mm <sup>2</sup>
Conductor	≥ 16 x ≤ 0,2 mm
Lay ratio	≥ 20 twists / m
Overall shield	Braided, tin-plated copper wire, diameter Ø ≥ 1,1 mm <sup>2</sup> 85 % optical coverage
Overall diameter - Ø	5 mm
External sheath	Depending on the requirements regarding flame retardation, deposits after burning etc.

**NOTE**

- All information should only be considered as a recommendation.
- Deviations or different measures may be required depending on the particular requirements, the specific application and the conditions on site.

Table 3-17 Thermal and electrical characteristics

Cable resistance (20°C)	≤ 40 Ω/κm
Insulation resistance (20°C)	≥ 200 MΩ/km
Operating voltage (20°C)	≥ 300 V
Test voltage (20°C)	≥ 1500 V
Temperature range	-40 °C ≤ T ≤ 80 °C
Load capability	≥ 5 A
Capacitance	≤ 120 pF/m

**Mechanical characteristics**

- Single bending: ≤ 5 x outer diameter
- Repeated bending: ≤ 20 x outer diameter

**Recommendations**

- Standard cable, without any special requirements:  
Two-core, flexible, shielded conductor in accordance with VDE 0812, with colored PVC sheath. PVC insulation resistant to oil, resistant to cold and petroleum products.  
Type: LiYCY 2 x 0,5 mm<sup>2</sup>  
e.g. Fa. Metrofunk Kabel-Union GmbH, [www.metrofunk.de](http://www.metrofunk.de)  
Postfach 41 01 09, 12111 Berlin
- Halogen-free cable (no hydrochloric acid is generated when the cable burns):  
Halogen-free, highly flexible, resistant to extreme heat and cold. Sheath manufactured from a special ASS silicon-based composite.  
Type: ASS 1 x 2 x 0,5 mm<sup>2</sup>  
e.g. Fa. Metrofunk Kabel-Union GmbH, [www.metrofunk.de](http://www.metrofunk.de)  
Postfach 41 01 09, 12111 Berlin
- Recommended if halogen-free and silicon-free cables are required:  
Type: BETAflam 145 C-flex: 2x0,5 mm<sup>2</sup>  
e.g. Fa. Studer-Kabel-AG, <http://www.studer-kabel.ch/>  
Herrenmattstrasse 20, CH 4658 Däniken

The total cable length of the USS connection may not exceed 50 m (max. cable length).

The max. data transfer rate depends on the number of connected nodes (devices) as well as on the closed-loop control technique / function selection (processor utilization). Nominal values can be taken from the following table:

Table 3-18 Max. number of nodes (devices) depending on the max. data transfer rate

Max. data transfer rate	Max. number of nodes (devices)	
	V/f control	Closed-loop vector control
9.6 kbit/s	32	32
19.2 kbit/s	32	32
38.4 kbit/s	32	7
93.7 kbit/s	32	-
115.2 kbit/s	32	-

**NOTE**

If a higher baud rate or higher number of nodes is required, then the CB option boards (e.g. PROFIBUS, CAN) should be used to ensure disturbance-free operation.

**3.7.1.2 The structure of net data**

Information which, for example, a SIMATIC S7 control unit (= master) sends to a drive (= slave) or the drive sends to the control unit is placed in the net-data area of each telegram.

**General structure of the net-data block**

The net-data block is divided into two areas:

- the PKW (parameter ID value) range
- the PZD (process data) range

The structure of the net data in the USS-protocol telegram is shown below.

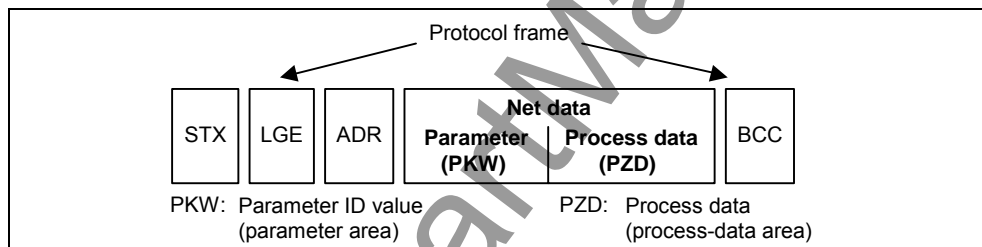


Fig. 3-45 Telegram structure

- The **PKW area** relates to the handling of the parameter ID value (PKW) interface. The PKW interface is not a physical interface but a mechanism which handles parameter transfer between two communication partners (e.g. control unit and drive). This involves, for example, reading and writing parameter values and reading parameter descriptions and associated texts. All tasks which are performed via the PKW interface essentially involve operator control and visualization, service and diagnosis.
- The **PZD area** contains the signals required for the **automation** system:
  - ◆ Control word(s) and setpoint(s) from the master to the slave
  - ◆ Status word(s) and actual value(s) from the slave to the master.

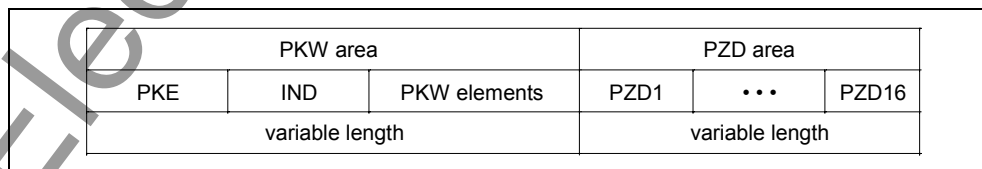


Fig. 3-46 Structure of the PKW and PZD areas

- ◆ The two areas together make up the net data block. This structure applies to telegrams from the master to the slave and vice versa.

### PKW area

With the help of the PKW mechanism, the following tasks can be performed via any serial interface with the USS protocol:

- Reading and writing parameters
- Reading the description of a parameter

The PKW area can be varied. Depending on the requirements, the following lengths can be parameterized using parameter P2013:

- 3 words → P2013 = 3
- 4 words → P2013 = 4
- variable word length → P2013 = 127

The following is an example of a structure when access (write/read) is made to **single-word** (16 bit) parameter values. The PKW area must be permanently set to 3 words at the master and the slave. This setting is made during start-up and should not be altered any more during bus operation.

1st word	2nd word	3rd word
PKE	IND	PWE1
Parameter ID	Index	Parameter value 1

The following is an example of a structure when access (write/read) is made to **double-word** (32 bit) parameter values. Parameterization to a fixed length of 4 words applies to telegrams from the master to the slave and from the slave to the master.

1st word	2nd word	3rd word	4th word
PKE	IND	PWE1	PWE2
Parameter ID	Index	Parameter value (double word)	

Telegram data transfer with variable telegram length (refer to the following example) means that the slave responds to a telegram from the master with a telegram whose length does not have to be the same length as the telegram from the master to the slave.

1st word	2nd word	3rd word	4th word	.....	(m+2). word
PKE	IND	PWE1	PWE2		

With:

- 1 word  $\leq m \leq 118$  words (maximum) when 8 PZD words (maximum) are contained in the net data block.
- 1 word  $\leq m \leq 126$  words (maximum) when there is no PZD.

The length of elements PEW1 to PEW<sub>m</sub> in the reply telegram and what is contained in them depends on the task issued by the master. Variable length means that only the number of words necessary to pass on the appropriate information is transferred. The minimum length, however, is always 3 words. If a slave, for example, transfers a parameter value which is a 16-bit quantity (e.g. the status word in parameter r0052; data format: U16), then only 3 words of the PKW area are sent in the telegram from the slave to the master. If, for example, for MICROMASTER the actual frequency is to be read (parameter r0021), then the PKW area in the telegram from the slave to the master is 4 words large; the reason for this is that the speed is represented as 32-bit quantity (data format: Float). It is mandatory to parameterize for a variable word length, if e.g. all values are to be

read at once from an "indexed" parameter (refer to "Index", special setting, index = 255). This setting to variable word-length is made during start-up. (refer to parameter P2013).

Parameter ID (PKE)														1st word		
15	14	13	12	11	10	9	8	7	6	5	4	3	2	1	0	Bit No.:
AK				SP M	PNU1											

Parameter index (IND)														2nd word		
15	14	13	12	11	10	9	8	7	6	5	4	3	2	1	0	Bit No.:
PNU2				RES	TXT	Index										

Parameter value (PWE)														3rd word		
15	14	13	12	11	10	9	8	7	6	5	4	3	2	1	0	Bit No.:
Parameter value, high (PWE1)										Parameter value, low (PWE2)					4th word	

The following applies:

- AK Task or reply ID
- SPM Toggle bit for processing of parameter-change reports (MICROMASTER does not support this, SPM = 0)
- PNU Parameter number
- RES Reserved
- TXT Read / write from parameter text (MICROMASTER does not support this, TXT = 0)

#### CAUTION

- Do not use a variable word length if SIMATIC S5 or SIMATIC S7 is the master.
- This setting must be made both at the master as well as at the slave – and cannot be changed while the bus is operational.

#### NOTE

- The PKW area is transferred in increasing order, always starting with the 1st word.
- Reserved fields or functions that are not supported should be specifically pre-assigned zero in the master implementation.
- The bit 11 (SPM) is the toggle bit for parameter change reports. Parameter change reports when reading/writing parameter texts are not supported by MICROMASTER.

**Task or reply ID (AK):**

Bits 12 to 15 (AK) contain the task or reply ID. The **task IDs** are sent in the telegram from the master to the slave. The meaning of the IDs is listed in the following table.

Table 3-19 Task IDs (master -&gt; drive converter)

Task ID	Meaning	Reply ID	
		positive	negative
0	No task	0	-
1	Request parameter value	1 or 2	7
2	Change parameter value (word) and save only in RAM	1	7 or 8
3	Change parameter value (double word) and save only in RAM	2	7 or 8
4	Request descriptive element <sup>1</sup>	3	7
5	Changing the descriptive element <sup>1</sup> MICROMASTER does not support this	3	7 or 8
6	Request parameter value (array) <sup>1</sup>	4 or 5	7
7	Change parameter value (array, word) <sup>2</sup> and save only in RAM	4	7 or 8
8	Change parameter value (array, double word) <sup>2</sup> and save only in RAM	5	7 or 8
9	Request the number of array elements	6	7
10	Reserved	-	-
11	Change parameter value (array, double word) and save in RAM and EEPROM <sup>2</sup>	5	7 or 8
12	Change parameter value (array, word) and save in RAM and EEPROM <sup>2</sup>	4	7 or 8
13	Change parameter value (double word) and save in RAM and EEPROM	2	7 or 8
14	Change parameter value (word) and save in RAM and EEPROM	1	7 or 8
15	Read or change text MICROMASTER does not support this	15	7 or 8

<sup>1</sup> The required element of the parameter description is specified in IND (2nd word)

<sup>2</sup> The required element of the indexed parameter is specified in IND (2nd word)

Correspondingly, the **Response IDs** are transferred in the telegram from the slave to the master at this position. Depending on the request ID, only specific response IDs are possible.

Table 3-20 Response ID (converter -> master)

Response ID	Significance	Request ID
0	No response	0
1	Transfer parameter value (word)	1, 2 or 14
2	Transfer parameter value (double word)	1, 3 or 13
3	Transfer descriptive element <sup>1</sup>	4 or 5
4	Transfer parameter value (array, word) <sup>2</sup>	6, 7 or 12
5	Transfer parameter value (array, double word) <sup>2</sup>	6, 8 or 11
6	Transfer the number of array elements	9
7	Request cannot be executed (with fault number)	1 or 15
8	The PKW interface does not have master authority	2, 3, 5, 7, 8, 11-14 or 15
9	Parameter change report (word) MICROMASTER does not support this	-
10	Parameter change report (double word) MICROMASTER does not support this	-
11	Parameter change report (array, word) <sup>2</sup> MICROMASTER does not support this	-
12	Parameter change report (array, double word) <sup>2</sup> MICROMASTER does not support this	-
13	Reserved	-
14	Reserved	-
15	Transfer text MICROMASTER does not support this	15

<sup>1</sup> The required element of the parameter description is specified in IND (2nd word)

<sup>2</sup> The required element of the indexed parameter is specified in IND (2nd word)

If the response ID has the value 7 (request cannot be executed), then a **fault number** is saved in parameter value 2 (PWE2). The fault numbers are documented in the following table.

Table 3-21 Fault numbers for the response ID "Request cannot be executed"

Fault No.	Significance
0	Inadmissible legal parameter number (PNU); if PNU is not available
1	Parameter value cannot be changed; if the parameter is a visualization parameter
2	Lower or upper limit exceeded
3	Erroneous sub-index
4	No array
5	Incorrect type of data
6	Setting not permitted (can only be reset)
7	Descriptive element cannot be changed; not possible
11	No operator control rights
12	Key word missing, device parameter: 'access key' and/or 'special parameter access' not appropriately set
15	No text array available
17	Request cannot be executed due to operating states; The frequency inverter state presently does not allow the request that was issued
101	Parameter number presently de-activated; In the present frequency inverter state, the parameter has no function (e.g. closed-loop control type)
102	Channel width too small: Only for short channels; the parameterized length of the PKW area has been selected too large due to the restrictions in the device. This fault message can only occur for the USS protocol on the technology module T 100 if basic device parameters are accessed from this interface
103	Incorrect PKW number; only for G-SST 1/2 and SCB interface (USS). The fault number is transferred in the following two cases: <ul style="list-style-type: none"> <li>➤ If the request involves all indices of an indexed parameter (request index equal to 255) or the complete parameter description is requested and a variable telegram length was not parameterized.</li> <li>➤ If, for the request issue, the parameterized number of PKW data in the telegram is too low (e.g. Changing from a double word and PKW number equal to 3 (words).</li> </ul>
104	Parameter value not permissible; This fault number is transferred if the parameter value – that is to be transferred – is not assigned any function in the device or at the time of the change it is not able to be transferred for internal reasons (although it lies within the limits).
105	The parameter is indexed e.g. request: 'PWE, change word' for indexed parameters
106	Request not implemented
200	New minimum value
201	New maximum value
203	No BOP/AOP display, Parameter cannot be displayed on the BOP or AOP.
204	The 'BOP/AOP key word' does not match the parameter access stage.

**Parameter number (PNU)**

The complete parameter number (refer to the parameter list) is formed from the "basis parameter number" PNU1 and the "page parameter number" PNU2. The following applies:

$$PNU = PNU1 + 2000 \cdot PNU2$$

With PNU2 definition:

<b>PNU2</b>				2nd word
15	14	13	12	Bit No.:
20	23	22	21	Weighting

The parameter areas are mapped using PNU1 and PNU2 as follows:

Basis parameter number PNU1 bits 0 – 10 (PKE)	Page parameter number PNU2 bits 12 – 15 (IND)	Parameter number (area)
0 ... 1999	0	0 ... 1999
0 ... 1999	1	2000 ... 3999
0 ... 1999	2	4000 ... 5999
0 ... 1999	3	6000 ... 7999
0 ... 1999	4	8000 ... 9999
...	...	...
0 ... 1999	15	30000 ... 31999

**Index**

The index (bit 0 to 7), depending on the task, describes a definite element:

- desired array element in the case of indexed parameters,
- desired element of the parameter description,

Special significance of index value 255

For the following requests, the index value 255 has a special significance:

- "request parameter descriptive element", or.
- for the requests to read/write indexed parameters (= arrays)

Here, the following applies:

Task ID	Meaning
4	The complete parameter description is requested
6	All values of the indexed parameters are requested This request can generate fault message 102.
7, 8, 11 or 12	All values of the indexed parameters should be changed. These requests can generate fault message 102.

### Parameter value (PWE)

The parameter value (PWE) is transferred, depending on the parameterization of the word length (refer to parameter "USS-PKW length" P2013) of the PKW area as word or double word (32 bit). Only one parameter value can be transferred in a telegram.

If the word length of the PKW area is parameterized with 3 words (P2013 = 3), then only 16-bit parameters can be transferred. Parameter descriptive elements, that are greater than 16 bit cannot be transferred.

If the word length of the PKW area is parameterized to be 4 words (P2013 = 4), then 16 and 32-bit parameters can be transferred. Parameter descriptive elements that exceed 32 bits cannot be transferred.

If the word length of the PKW area is parameterized with "variable length" (P2013 = 127), then 16, 32-bit parameter and parameter descriptive elements can be transferred. Further, all elements of an indexed parameter can be read or changed with a single request, as well as the complete parameter description requested if the index corresponds to the value 255 (index = 255).

Transferring **one** 16-bit parameter value:

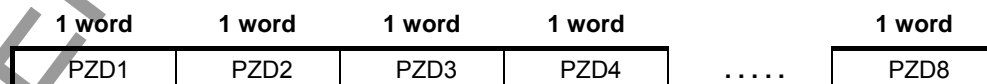
1. Fixed PKW area, 3 words:  
The value is in PWE1
2. Fixed PKW area, 4 words:  
The value is in PWE2 (least significant word, 4th word); PWE1 is set to 0.
3. Variable PKW area:  
The value is in PWE1. PWE2 and higher not available!

Transferring **one** 32-bit parameter value:

1. Fixed PKW area, 3 words:  
Request is rejected with fault message 103.
2. Fixed PKW area, 4 words:  
PWE1 (most significant word; 3rd word) contains the high word of the double word,  
PWE2 (least significant word; 4th word) contains the low word of the double word.
3. Variable PKW area:  
As for 2.; PWE3 and higher not available!

### Process data area (PZD)

Process data is continually exchanged between the master and slaves in this area. At the start of communications it is configured as to which process data is to be exchanged with a slave. For instance, for slave x, the current setpoint is to be transferred in the second PZD (= PZD2). This setting remains for the complete data transfer.



**PZD1 – PZD8 = process data**  
= control / status word(s) and setpoint / actual value(s));

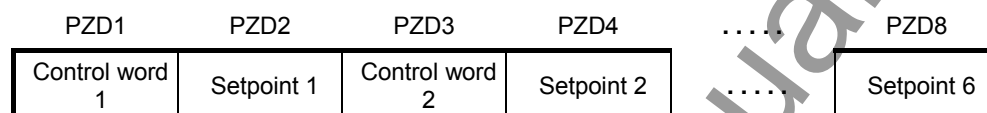
The control / status word(s), setpoints and actual values required for the automation are transferred in this area.

The length of the PZD area is defined by the number of PZD elements (P2012). Contrary to the PKW area, that can be variable, the length of this area between the communication partners (master and slave) must always be permanently declared.

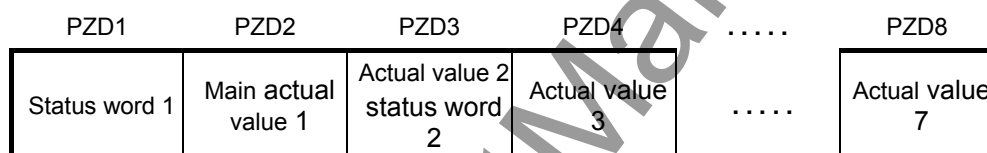
The maximum number of PZD words per telegram is, for MICROMASTER, limited to 8 words (USS-PZD length in MICROMASTER is set using parameter P2012). If only PKW data are to be transferred in the net data block, then the number of the PZD can also be 0!

Depending on the data transfer direction, always control word 1 or status word 1 are to be transferred in the PZD1. Depending on the data transfer direction, the main setpoint or the main actual value is always transferred in PZD 2. Additional setpoints or actual values are set in the following process data PZD3 to PZDn. For MICROMASTER, if required, control word 2 or status word 2 should be transferred in PZD4.

Request telegram, master  $\Rightarrow$  slave



Response telegram, slave  $\Rightarrow$  master



#### NOTE

- A maximum of 8 PZD words
- A minimum of 0 PZD words - i.e. no PZD area in the net data area
- On the USS bus, PZD n is always transferred before PZD n+1.
- For MICROMASTER, double words cannot be transferred in the PZD section.
- Data received from MICROMASTER is always interpreted as 16-bit words. The appropriate de-normalization is implemented by assigning the appropriate parameters.
- If MICROMASTER sends data to the master via the PZD area, then for physical quantities, a normalization is made to a 16-bit value (4000 hex notation).
- The setpoint can be freely assigned to the actual value; This means for example that the frequency setpoint is transferred in the request telegram in PZD2 so the actual frequency value can be signaled back in PZD2 in the response telegram (this also makes sense from a technological/process perspective); or however, also another actual value – such as the actual torque value, actual voltage actual value or actual current value. The setpoint can be freely assigned to the actual value; for example the frequency setpoint is transferred in the request telegram in PZD2, which means that the actual frequency value can be signaled back in the response telegram in PZD2 (this also makes sense from a technological/process perspective) – or also another actual value – such as actual torque value, actual voltage value or actual current value.

### 3.7.1.3 USS bus configuration via COM link (RS485)

In order to ensure disturbance-free USS operation, the bus cable must be terminated at both ends using bus terminating resistors. In this case, the bus cable from **the** first USS device [node] up to the last USS device [**node**] should be considered as one **bus** cable – so that the USS bus should be terminated twice. For the **first** bus node [device] (e.g. master) and **last** bus node [device] (e.g. drive converter), the bus terminating resistor must be switched-in.

#### NOTE

- ◆ When supplied, the bus terminating resistors are not switched-in!
- ◆ Please note that you only switch-in the bus terminating at the first bus node [device] and last bus node [device]! The **bus terminating** resistors should be always set with the system in a **no-voltage state** (e.g. powered-down)!
- ◆ **Data transfer errors on the bus are possible!**  
In active bus operation, devices where the terminating **resistor** is switched-in, may not be in a no-voltage state. The terminating resistor draws the voltage from the connected device. This is the reason that the terminating resistor is no longer effective when the device is in a no-voltage state (e.g. when powered down) .

The following diagram shows the structure of a bus connection through terminals 29, 30:

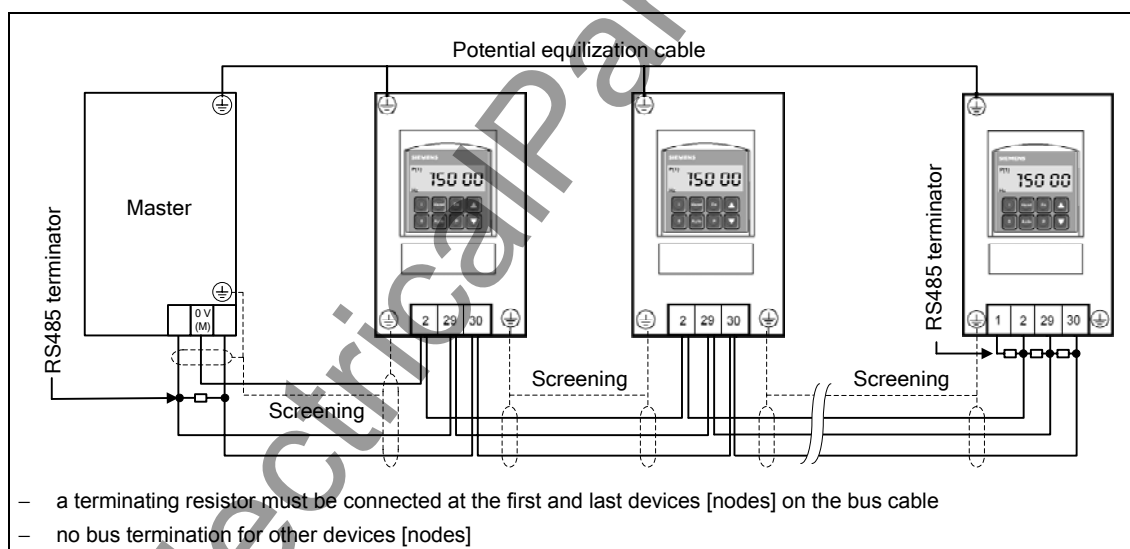


Fig. 3-47 Connecting the USS bus cable

When the MICROMASTER is used in an RS485 bus communications network the following is required:

1. A power supply
2. A terminating resistor between P+ and N- at both bus ends (refer to Fig. 3-48)

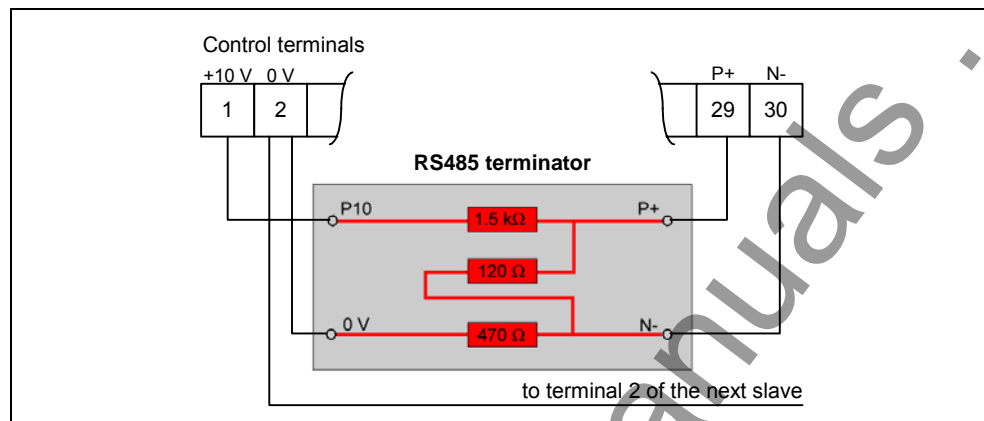


Fig. 3-48 Connecting the RS485 terminator

If the frequency inverter is the last slave on the bus (refer to Fig. 3-47), then the P+ and N- of the RS485 terminator provided must be connected there to the RS485 terminals (refer to Fig. 3-48). P10 and 0 V can be connected to terminals 1 and 2 for the power supply.

If the frequency inverter is the first slave, then the bus should only be terminated there with P+ and N- (120 Ω).

If the first or last bus node is not a MICROMASTER 4, then the bus between P+ and N- must be terminated with a resistor (between 120 Ω and 220 Ω).

The bus must be operated with a bias on one or on both ends (pull-up resistance from P+ to P5 or P10, pull-down resistance from N- to 0 V). If the first or last bus node is not a MICROMASTER 4 (e.g. a controller of the S7-200 series), the bus can then be biased by connecting 390 Ω resistors from P+ to P5 and from N- to 0 V.

If the first or last bus node is a controller of the S7-200 series, SIMATIC PROFIBUS connectors, e.g. 6ES7972-0BA41-0XA0, can be used for the bias and the termination.

---

**NOTE**

- When making the installation it must be ensured that EMC disturbances/noise cannot result in communication failures/errors or damage to the RS485 drivers. As a minimum, the following measures must be taken:
    - 1) Shield the motor cable and correctly ground the shield at both ends. If at all possible, avoid interruptions in the cables. If this cannot be avoided, then it must be ensured that the shield continues in an EMC-correct fashion at the connecting locations.
    - 2) All node points must be well grounded (EMC ground).
    - 3) All relay coils must be provided with noise suppression elements.
    - 4) The cables should be routed - as far as possible - separately from other cables. For RS485 cables it is especially important that they are kept well away from motor cables.
    - 5) The shields of RS485 cables must be correctly grounded.
  - If the AOP communicates via the USS protocol, then contrary to the BOP, the appropriate USS parameters (Table 3-13 and Table 3-14) should be set.
  - For error-free communications, the appropriate communication parameters must be harmonized with one another and correctly set - in the frequency inverter, the connected device and/or in the connected option board. Please refer to the corresponding Operating Instructions for the AOP and for the communications modules.
  - While RS485 communications is operational the power supply must always be available using pull-up/pull-down resistors.
-

### 3.8 Fixed frequencies (FF)

Number:	15
Parameter range:	P1001 – P1028
Warnings	-
Faults	-
Function chart number:	FP3200, FP3210

A setpoint can be entered via the analog inputs, the serial communication interfaces, the JOG function, the motorized potentiometer as well as also using fixed frequencies. The fixed frequencies are defined using parameters P1001 – P1015 and selected via binector inputs P1020 – P1023, P1025, P1026. The effective fixed frequency setpoint is available via connector output r1024 which means that it can be connected further. If this is to be used as setpoint source, then either parameter P1000 or P0719 should be modified or BICO parameter r1024 should be connected to the main setpoint P1070 or supplementary setpoint P1075. Contrary to parameter P0719, when parameter P1000 is modified, this implicitly changes BICO parameters P1070, P1075.

**Example:** Fixed frequencies as setpoint source

a) Standard method → P1000 = 3

b) BICO method → P1070 = 1024, P1075 = 0

3 methods are available when selecting the fixed frequencies.

#### Direct selection

In this particular mode, the control signal directly selects the fixed frequency. This control signal is entered via the binector inputs. If several fixed frequencies are simultaneously active, then the selected frequencies are added.

Table 3-22 Example for direct coding via digital inputs

		DIN6	DIN5	DIN4	DIN3	DIN2	DIN1
FF0	0 Hz	0	0	0	0	0	0
FF1	P1001	0	0	0	0	0	1
FF2	P1002	0	0	0	0	1	0
FF3	P1003	0	0	0	1	0	0
FF4	P1004	0	0	1	0	0	0
FF5	P1005	0	1	0	0	0	0
FF6	P1006	1	0	0	0	0	0
	FF1+FF2	0	0	0	0	1	1
	⋮						
	FF1+FF2+FF3+FF4+FF5+FF6	1	1	1	1	1	1

The fixed frequencies can be selected via the digital inputs as well as also via serial communication interfaces. The fixed frequency is selected, when using digital inputs, using 2 techniques. This will be shown in the following example using the fixed frequency P1001 and digital input 1 (refer to Fig. 3-49).

a) Standard methods → P0701 = 15

b) BICO methods → P0701 = 99, P1020 = 722.0, P1016 = 1

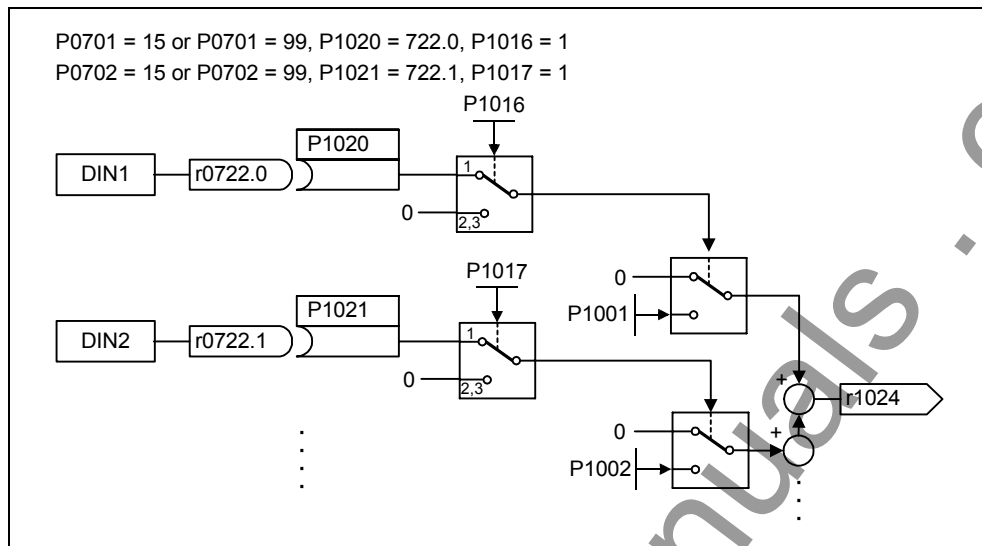


Fig. 3-49 Example for directly selecting FF1 via DIN1 and FF2 via DIN2

### Direct selection + ON command

When this fixed frequency is selected, the fixed frequencies are also directly selected whereby the selection is combined with the ON command. When this technique is used, a separate ON command is not required. The following is obtained essentially analog to the example shown above:

- a) Standard method → P0701 = 16
- b) BICO method → P0701 = 99, P1020 = 722.0, P1016 = 2

### Binary-coded selection + ON command

Using this technique up to 16 fixed frequencies can be selected using 4 control signals. These 4 control signals are either entered via digital inputs or a serial communications interface. The fixed frequencies are indirectly selected using the binary coding (refer to Table 3-23, → e.g. selected using the digital DIN inputs), whereby the selection is combined with the ON command.

Table 3-23 Example for binary coding via digital inputs

		DIN4	DIN3	DIN2	DIN1
0 Hz	FF0	0	0	0	0
P1001	FF1	0	0	0	1
P1002	FF2	0	0	1	0
...	...	...	...	...	...
...	...	...	...	...	...
P1014	FF14	1	1	1	0
P1015	FF15	1	1	1	1

Contrary to "Direct selection + ON command", the ON command is only active if the setting for the first 4 binary inputs is set to "Binary-coded selection + ON command" or P0701 = P0702 = P0703 = P0704 = 17. The following is obtained analog to the above example:

- a) Standard method → P0701 = 17
- b) BICO method → P0701 = 99, P1020 = 722.0, P1016 = 3

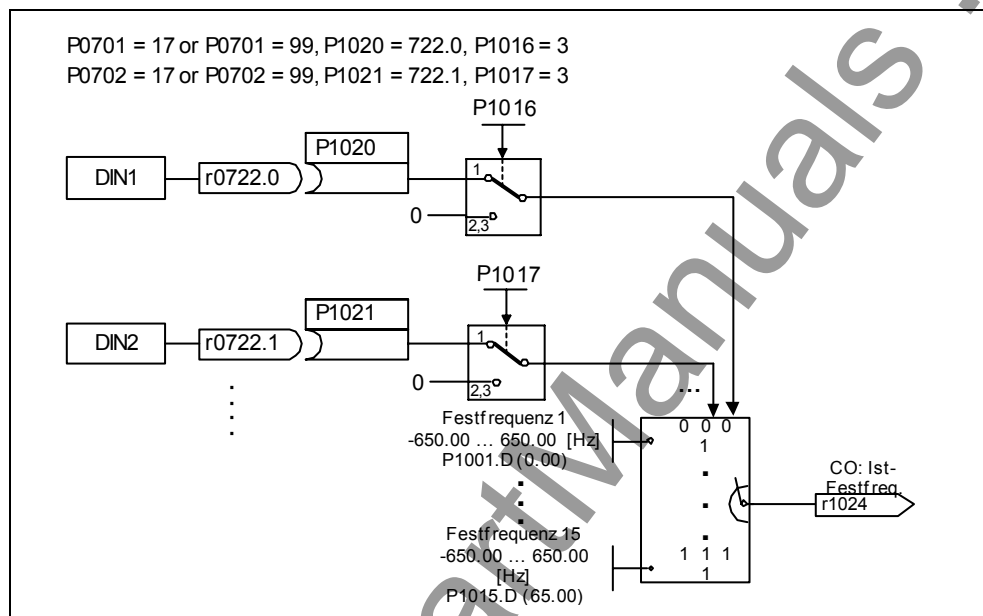


Fig. 3-50 Example for selecting FF1 via DIN1 and FF2 via DIN2 using the binary-coded method

### 3.9 Motorized potentiometer (MOP)

Parameter range: P1031 – r1050  
 Warnings -  
 Faults -  
 Function chart number: FP3100

This function emulates an electromechanical potentiometer to enter setpoints. The motorized potentiometer value is adjusted using the "Raise" and "Lower control signal" which is selected using BICO parameters P1035 and P1036 (refer to Fig. 3-51). The value which has been set is available through connector output r1050 so that it can be further connected and used.

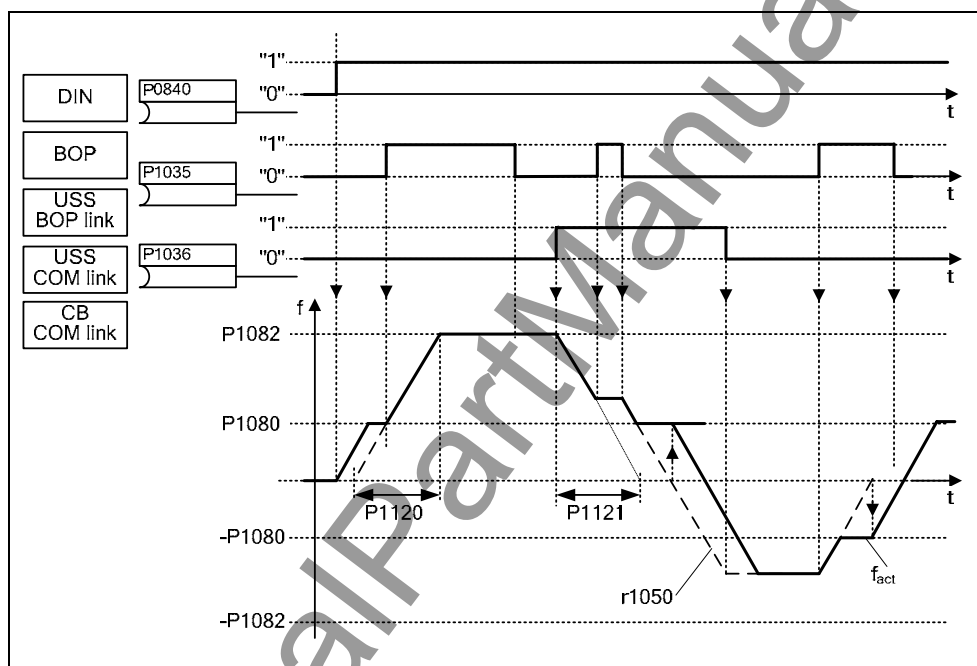


Fig. 3-51 Motorized potentiometer

#### Selecting via serial interfaces

The MOP functionality can be selected via the operator panels (refer to Section 3.2), digital inputs as well as via serial interfaces (refer to the example). Parameterization is also possible directly using BICO parameters P1035 and P1036 as well as also parameters P0700 and P0719. In this case, for a value assigned to P0700, the BICO parameter is appropriately modified.

**Example:** Command source via "USS on BOP link" interface

- a) Standard method → P0700 = 4
- b) BICO method → P1035 = 2032.13  
 P1036 = 2032.14  
 ⋮  
 (refer to P0700 for a complete list)

If the motorized potentiometer is to be used as setpoint source, then either parameter P1000 or P0719 should be modified or the BICO parameter r1050 should be connected to the main setpoint P1070 or supplementary setpoint P1075. Contrary to parameter P0719, when parameter P1000 is modified, this implicitly changes BICO parameters P1070, P1075.

**Example:** Setpoint via the motorized potentiometer (MOP)

- a) Standard method → P1000 = 1  
 b) BICO method → P1070 = 1050  
 P1075 = 0

The MOP is configured using the following parameters and has the mode of operation as shown in Table 3-24:

- Limits using the minimum frequency P1080 or maximum frequency P1082
- Ramp-up/ramp-down time P1120 or P1121
- Inhibits MOP reversing function P1032
- Saves the MOP setpoint P1031
- MOP setpoint P1040







Table 3-24 Mode of operation of the MOP

Motorized potentiometer		Function
Lower	Raise	
0	0	Setpoint is frozen
0	1	Raise setpoint
1	0	Lower setpoint
1	1	Setpoint is frozen

### Selecting via BOP or AOP

The following settings / operator actions should be made when selecting the motorized potentiometer using the BOP or AOP:

Table 3-25 Selecting the motorized potentiometer

Parameters / keys		BOP	AOP (at the BOP link)
Command source	P0700	1	4
Setpoint source	P1000	1	
	P1035	-	2032.13 (2032.D)
	P1036	-	2032.14 (2032.E)
			
			
		Raise MOP output frequency	
	Lower MOP output frequency		

### 3.10 JOG

Parameter range:	P1055 – P1061
Warnings	A0923
Faults	-
Function chart number:	FP5000

The JOG function is used as follows:

- To check the functionality of the motor and drive inverter after commissioning has been completed (the first traversing motion, checking the direction of rotation, etc.)
- Positioning a drive / a driven load into a specific position
- Traversing a drive, e.g. after a program has been interrupted

The drive is traversed using this function by entering fixed frequencies P1058, P1059. The JOG mode can be selected either using the operator panel (refer to Section 3.2), digital inputs or also via the serial interfaces (refer to the example). An ON/OFF command is not used to move the drive, but when the "JOG keys" are pressed. These "JOG keys" are selected using the BICO parameters P1055 and P1056.

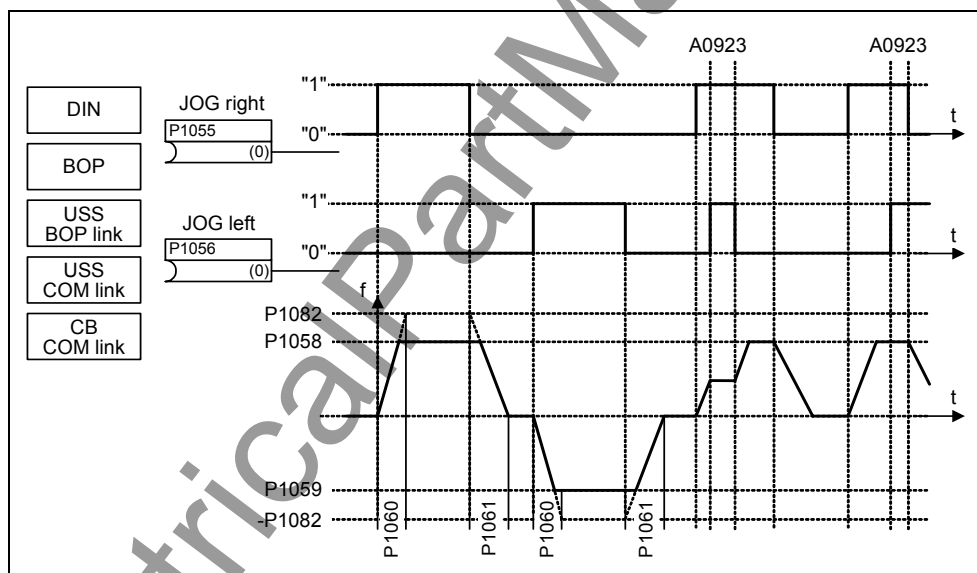


Fig. 3-52 JOG counter-clockwise and JOG clockwise

If both JOG keys are simultaneously pressed, then the instantaneous frequency is kept (constant velocity phase) and alarm A0923 is output. When a key is pressed, the drive inverter accelerates the motor to the fixed frequency in the time entered in P1060. This frequency is only exited after the key has been cancelled and the drive then brakes down to 0 Hz in the time entered in P1061.

In addition to the explicit parameterization (P1055 and P1056), the JOG functionality is also enabled via parameter P0700 or P0719 (implicit parameterization). In this case, if a value is assigned to P0700, the BICO parameter is appropriately modified.

**Example:** Command source via "USS on BOP link" interface

- |                    |   |                                      |
|--------------------|---|--------------------------------------|
| a) Standard method | → | P0700 = 4                            |
| b) BICO method     | → | P1055 = 2032.8                       |
|                    |   | P1056 = 2032.9                       |
|                    |   | ⋮                                    |
|                    |   | (refer to P0700 for a complete list) |

### 3.11 PID controller (technological controller)

Parameter range:	P2200 P2201 – P2355
Warnings	-
Faults	-
Function chart number:	FP3300, FP3400, FP5100
Features:	
- cycle time:	8 ms

In addition to the open-loop/closed-loop control of a three-phase motor (standard application for a frequency inverter), MICROMASTER has a technology controller. This can be used to control process quantities – such as pressure or level. Depending on the application, different control structures are required to control process quantities. For MICROMASTER, the following structures have been integrated; these can be selected or de-selected using parameters P2200, P2251 (also refer to Fig. 3-53):

- a) Variable-speed drive (VSD)
- b) Closed-loop PID control
- c) Closed-loop dancer roll control

The PID controller – integrated in MICROMASTER – is required for control structures b) and c). The frequency inverter can address many new applications using the higher-level control (closed-loop PID/dancer roll control). The following typical applications can be implemented:

- Closed-loop pressure control for extruders
- Closed-loop water level control for pump drives
- Closed-loop temperature control for fan drives
- Closed-loop dancer roll position control for winder applications
- And similar control tasks

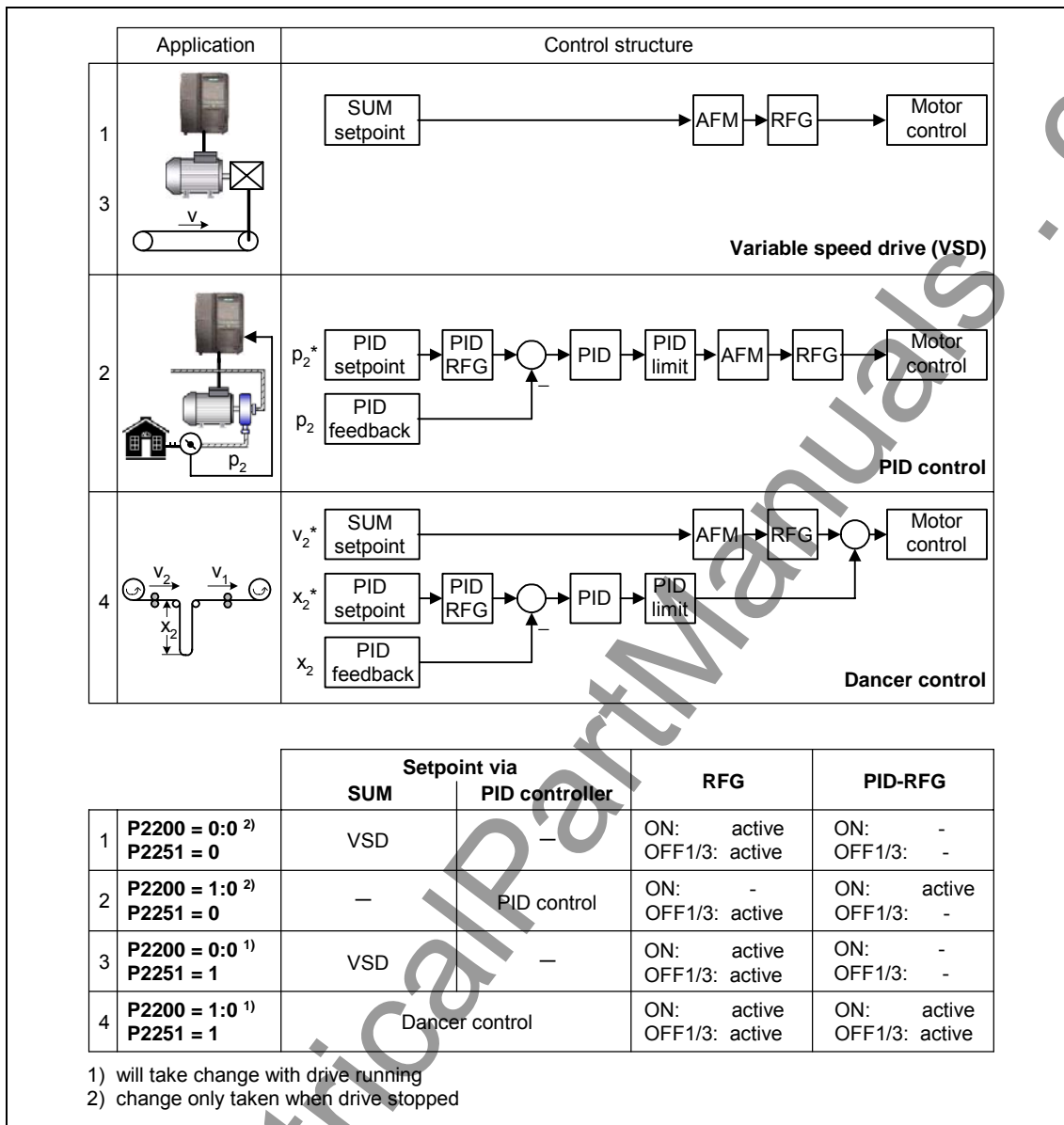


Fig. 3-53 Structure of the technology controller

### 3.11.1 Closed-loop PID control

MICROMASTER has a technological controller (PID controller, enabled using P2200); this can be used to execute basic, higher-level control functions.

The technological setpoints and actual values can be entered via the PID motorized potentiometer (PID-MOP), PID fixed setpoint (PID-FF), analog inputs (ADC, ADC2) or via serial interfaces (USS on BOP link, USS on COM link, CB on COM link) (refer to the example). The appropriate parameterization of the BICO parameter defines which setpoints or actual values are to be used (refer to Fig. 3-54).

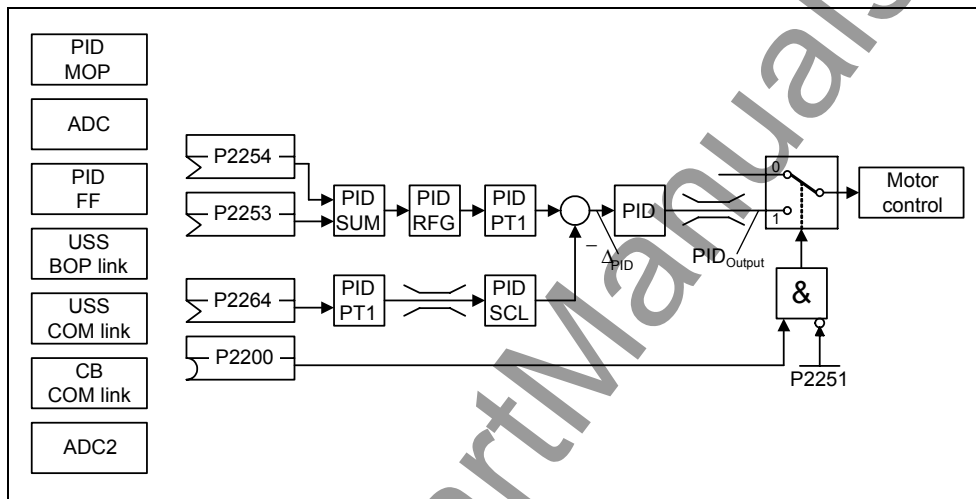


Fig. 3-54 Structure of the technological controller (PID controller)

Important parameter settings for the setpoint and actual value sources of the closed-loop PID control:

Parameter	Parameter text	Setting	Meaning
P2200	BI: Enable PID controller	1.0	PID controller always active
		722.x	Digital input x
P2251	PID mode	0	PID as setpoint
P2253	CI: PID setpoint	2224	Fixed PID setpoint (PID-FF)
		2250	PID-MOP
		755.0	Analog input 1
		2015.1	USS on BOP link
		2019.1	USS on COM link
P2264	CI: PID feedback	2050.1	CB on COM link
		755.0	Analog input 1
		755.1	Analog input 2

**NOTICE**

Changes in parameter P2200 take effect only after a fresh ON command.

**Example: Permanent PID controller should fulfill the following secondary conditions:**

PID controller enable and PID setpoint input via PID fixed frequencies and PID actual value via the analog input

**Parameterization:**

- |   |              |
|---|--------------|
| a) Permanent PID controller enable:         | P2200 = 1.0  |
| b) Setpoint input via PID-FF:               | P2253 = 2224 |
| c) Actual value input via analog input ADC: | P2264 = 755  |
| d) Setpoint input via PID:                  | P2251 = 0    |

The supplementary (additional) setpoint is added to the main setpoint (PID-SUM) and the sum is fed to the setpoint filter (PID-PT1) at the setpoint-actual value summation point via the PID ramp-function generator (PID-RFG). The source of the supplementary setpoint (BICO parameter P2254), the ramp-up / ramp-down times of the PID ramp-function generator (P2257, P2258) as well as also the filter time (P2261) can be adapted to the particular application by appropriately parameterizing the corresponding parameters.

Similar to the PID setpoint branch, the actual value branch of the technological controller has a filter (PID-PT1) which can be set using parameter P2265. In addition to the smoothing, the actual value can be modified using a scaling unit (PID-SCL).

The technological controller can be parameterized as either P, I, PI or PID controller using parameters P2280, P2285 or P2274.

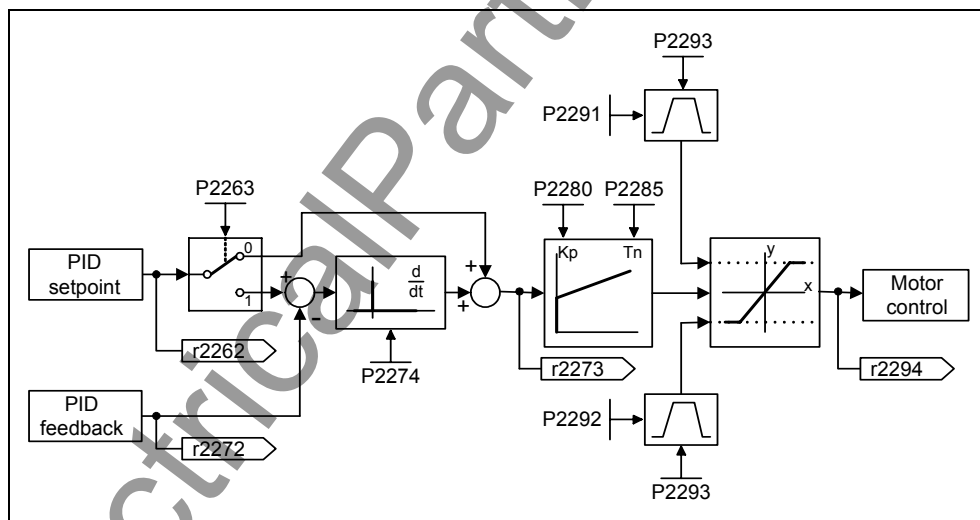


Fig. 3-55 PID controller

For specific applications, the PID output quantity can be limited to defined values. This can be achieved using the fixed limits - P2291 and P2292. In order to prevent the PID controller output exercising large steps at power-on, these PID output limits are ramped-up with ramp time P2293 from 0 to the corresponding value P2291 (upper limit for the PID output) and P2292 (lower limit for the PID output). As soon as these limits have been reached, the dynamic response of the PID controller is no longer limited by this ramp-up/ramp-down time (P2293).

### 3.11.1.1 PID motorized potentiometer (PID-MOP)

Parameter range: P2231 – r2250  
 Warnings -  
 Faults -  
 Function chart number: FP3400

The PID controller has a PID motorized potentiometer which can be separately adjusted. The functionality is identical with the motorized potentiometer (refer to Section 3.9), whereby the PID parameters are emulated in the range from P2231 – r2250 (refer to the comparison → Table 3-26).

Table 3-26 Correspondence between the parameters

PID motorized potentiometer		Motorized potentiometer	
P2231[3]	Setpoint memory of PID-MOP	P1031[3]	Setpoint memory of the MOP
P2232	Inhibit rev. direct. of PID-MOP	P1032	Inhibit reverse direction of MOP
P2235[3]	BI: Enable PID-MOP (UP-CMD)	P1035[3]	BI: Enable MOP (UP command)
P2236[3]	BI: Enable PID-MOP (DOWN-CMD)	P1036[3]	BI: Enable MOP (DOWN command)
P2240[3]	Setpoint of PID-MOP	P1040[3]	Setpoint of the MOP
r2250	CO: Output setpoint of PID-MOP	r1050	CO: Act. output freq. of the MOP

### 3.11.1.2 PID fixed setpoint (PID-FF)

Number:	15
Parameter range:	P2201 – P2228
Warnings	-
Faults	-
Function chart number:	FP3300, FP3310

Analog to the fixed frequencies (refer to Section 3.7), the PID controller has separate programmable PID fixed setpoints. The values are defined using parameters P2201 – P2215 and are selected using binector inputs P2220 – P2223, P2225, P2226. The selected PID fixed setpoint is available via connector output r2224 where it can be further processed (e.g. as PID main setpoint → P2253 = 2224).

3 methods are available to select the PID fixed setpoints, analog to the fixed frequencies (Section 3.7):

- Direct selection
- Direct selection + ON command
- Binary-coded selection + ON command

The methods are selected using parameters P2216 – P2219, P2225, P2227.

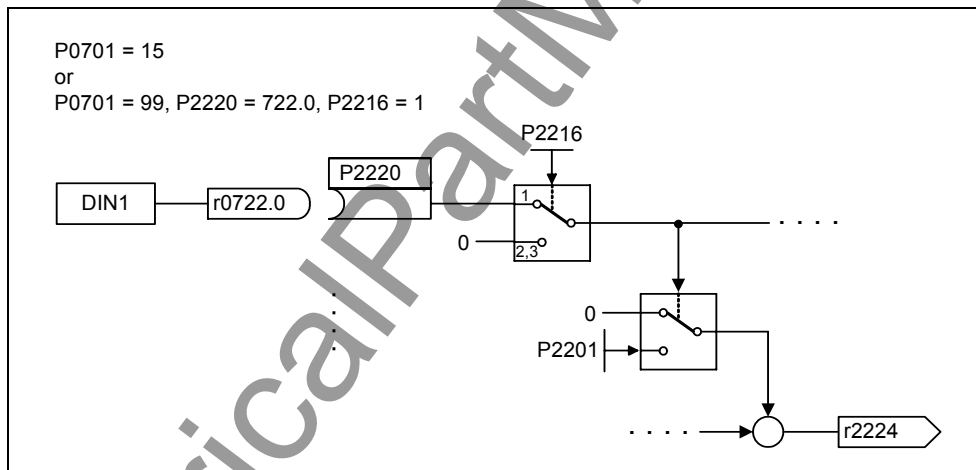


Fig. 3-56 Example to directly select the PID fixed frequency of fixed frequency 1 via DIN1

### 3.11.1.3 PID dancer roll control

For various continuous production processes, e.g. in the paper and pulp industry, or in the manufacture of cables, it is necessary to control (closed-loop) the velocity of stations along the production process so that the continuous material web is not subject to any inadmissible tension levels. It is also important that no folds or creases are formed. For applications such as these, it is practical to provide a type of material buffer in the form of a loop with a defined tension. This provides a decoupling between the individual drive locations. This loop represents the difference between the material fed-in and that fed-out and therefore indicates the process quality.

Using the PID dancer roll control, with MICROMASTER 440 it is possible to ensure that continuous material webs have a constant tension.

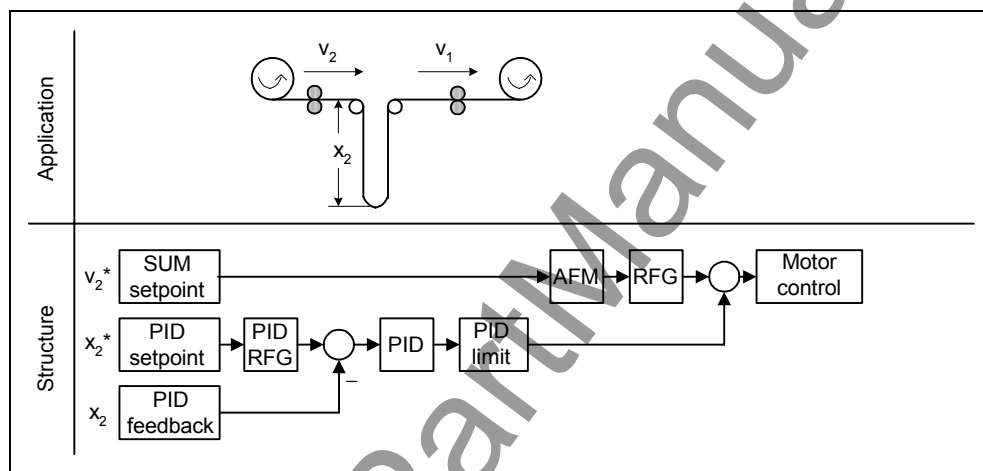


Fig. 3-57 PID dancer roll control

The velocity  $v_1$  is assumed to be an independent disturbance; the input velocity  $v_2$  should be controlled using drive rolls  $A_2$  so that the length  $x_2$  of the loop corresponds, as far as possible, to the setpoint.

The structure and important parameters for the PID dancer roll control are listed in Fig. 3-58 and Table 3-27.

**NOTE**

When selecting the closed-loop dancer roll control it should be noted that neither PID-MOP nor PID-FF should be used - but instead the MOP (motorized potentiometer, refer to Section 3.9) or the FF (fixed frequencies, refer to Section 3.7).

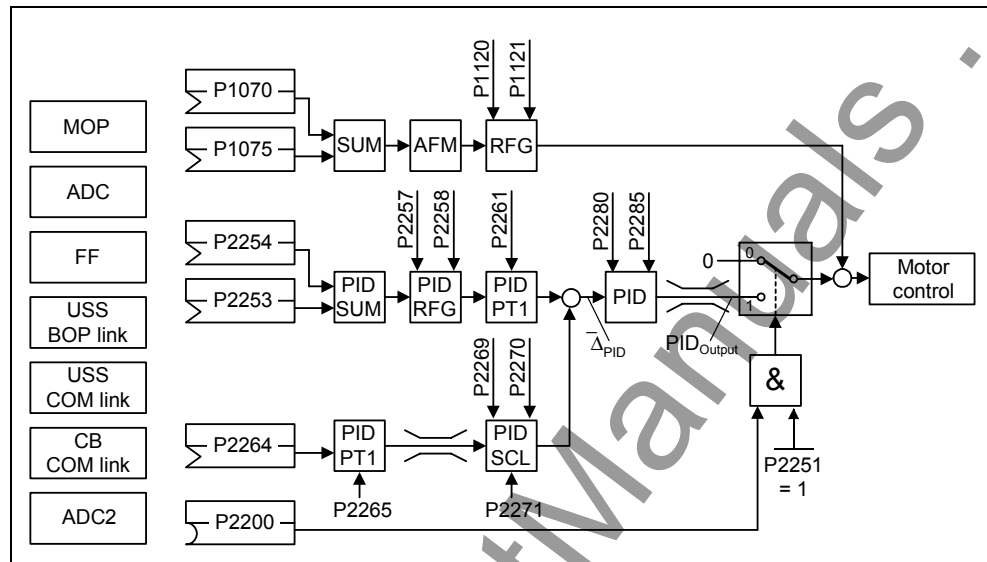


Fig. 3-58 Structure of the closed-loop PID-dancer roll control

Table 3-27 Important parameters for the PID dancer roll control

Parameter	Parameter text	Setting	Meaning
P1070	CI: Main setpoint	1024	Fixed setpoint (FF)
		1050	MOP
		755.0	Analog input 1
		2015.1	USS on BOP link
		2019.1	USS on COM link
		2050.1	CB on COM link
P2200	BI: Enable PID controller	1.0	PID controller always active
		722.x	Digital input x
P2251	PID mode	1	PID as trim
P2253	CI: PID setpoint	1024	Fixed setpoint (FF)
		1050	MOP
		755.0	Analog input 1
		2015.1	USS on BOP link
		2019.1	USS on COM link
		2050.1	CB on COM link
P2264	CI: PID feedback	755.0	Analog input 1
		755.1	Analog input 2

### 3.12 Setpoint channel

The setpoint channel (refer to Fig. 3-59) forms the coupling element between the setpoint source and the closed-loop motor control. MICROMASTER has a special characteristic which allows the setpoint to be entered simultaneously from two setpoint sources. The generation and subsequent modification (influencing the direction, suppression frequency, up/down ramp) of the complete setpoint is carried-out in the setpoint channel.

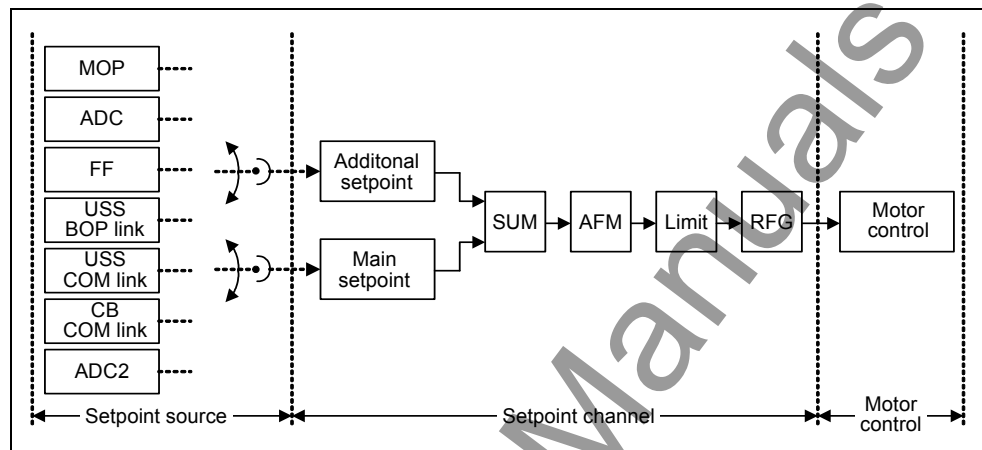


Fig. 3-59 Setpoint channel

#### 3.12.1 Summation and modification of the frequency setpoint (AFM)

Parameter range: P1070 – r1114

Warnings -

Fault -

Function chart number: FP5000, FP5200

For applications where the control quantities are generated from central control systems, fine tuning is often required locally on-site (correction quantity). For MICROMASTER, this can be very elegantly realized using the summation point where the main and supplementary (additional) setpoint are added in the setpoint channel. In this case, both quantities are simultaneously read-in via two separate or one setpoint source and summed in the setpoint channel. Depending on external circumstances, the supplementary setpoint can be dynamically disconnected or switched-in to the summation point (refer to Fig. 3-60). This functionality can be used to advantage, especially for discontinuous processes.

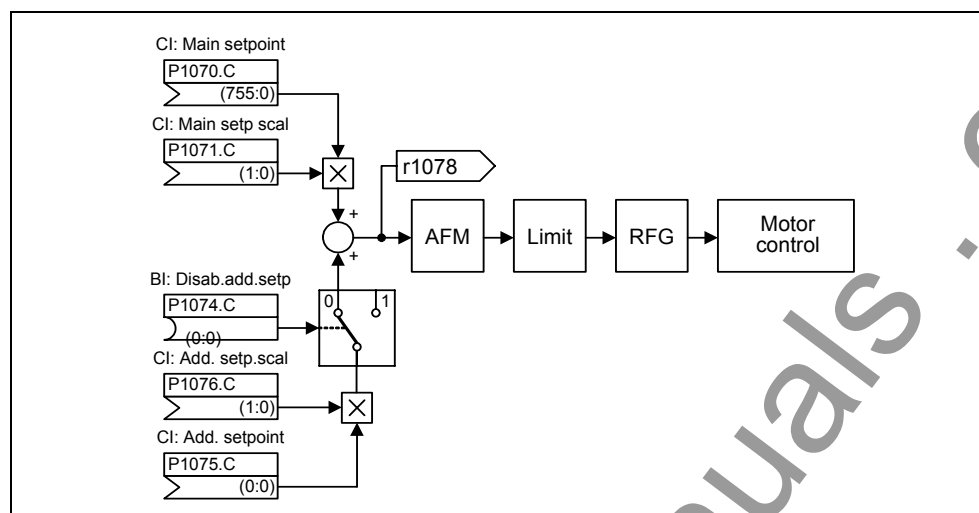


Fig. 3-60 Summation

MICROMASTER has the following possibilities to select the setpoint source:

1. P1000 – selecting the frequency setpoint source
2. P0719 – selecting the command / setpoint source
3. BICO parameterization
  - P1070 CI: Main setpoint
  - P1075 CI: Additional setpoint

Further, the main setpoint as well as the supplementary (additional) setpoint can be scaled independently of one another. In this case, for example, a user can simply implement an override function using the appropriate parameterization.

A scan sequence is generally associated with a forwards and a backwards motion. When selecting the reversing functionality, after reaching the end position, a direction of rotation reversal can be initiated in the setpoint channel (refer to Fig. 3-61).

On the other hand, if it is to be prevented that a direction of rotation reversal or a negative frequency setpoint is to be entered via the setpoint channel, then this can be inhibited using BICO parameter P1110.

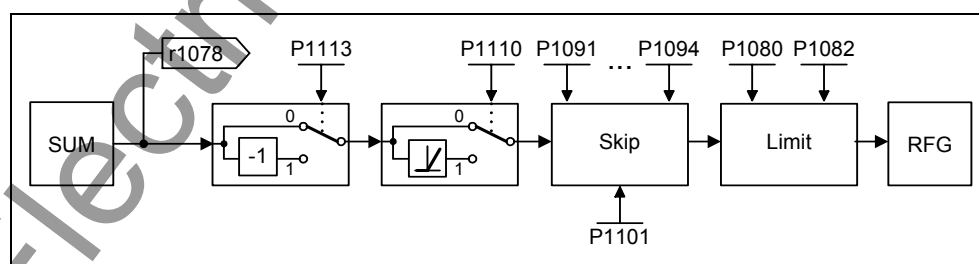


Fig. 3-61 Modifying the frequency setpoint

Driven machines can have one or several resonance points in the range from 0 Hz up to the reference frequency. These resonance points result in oscillations which, under worst case conditions, can damage the driven load. Using suppression frequencies, MICROMASTER allows these resonant frequencies to be passed through as quickly as possible. This means that the suppression frequencies increase the availability of the driven load over the long term.

### 3.12.2 Ramp-function generator (RFG)

Parameter range: P1120, P1121  
r1119, r1170  
P1130 – P1142

Warnings -  
Faults -  
Function chart number: FP5000, FP5300

The ramp-function generator is used to limit the acceleration when the setpoint changes according to a step function. This therefore helps to reduce the stressing on the mechanical system of the machine. An acceleration ramp and a braking ramp can be set independently of one another using the ramp-up time P1120 and the ramp-down time P1121. This allows a controlled transition when the setpoint is changed (refer to Fig. 3-62).

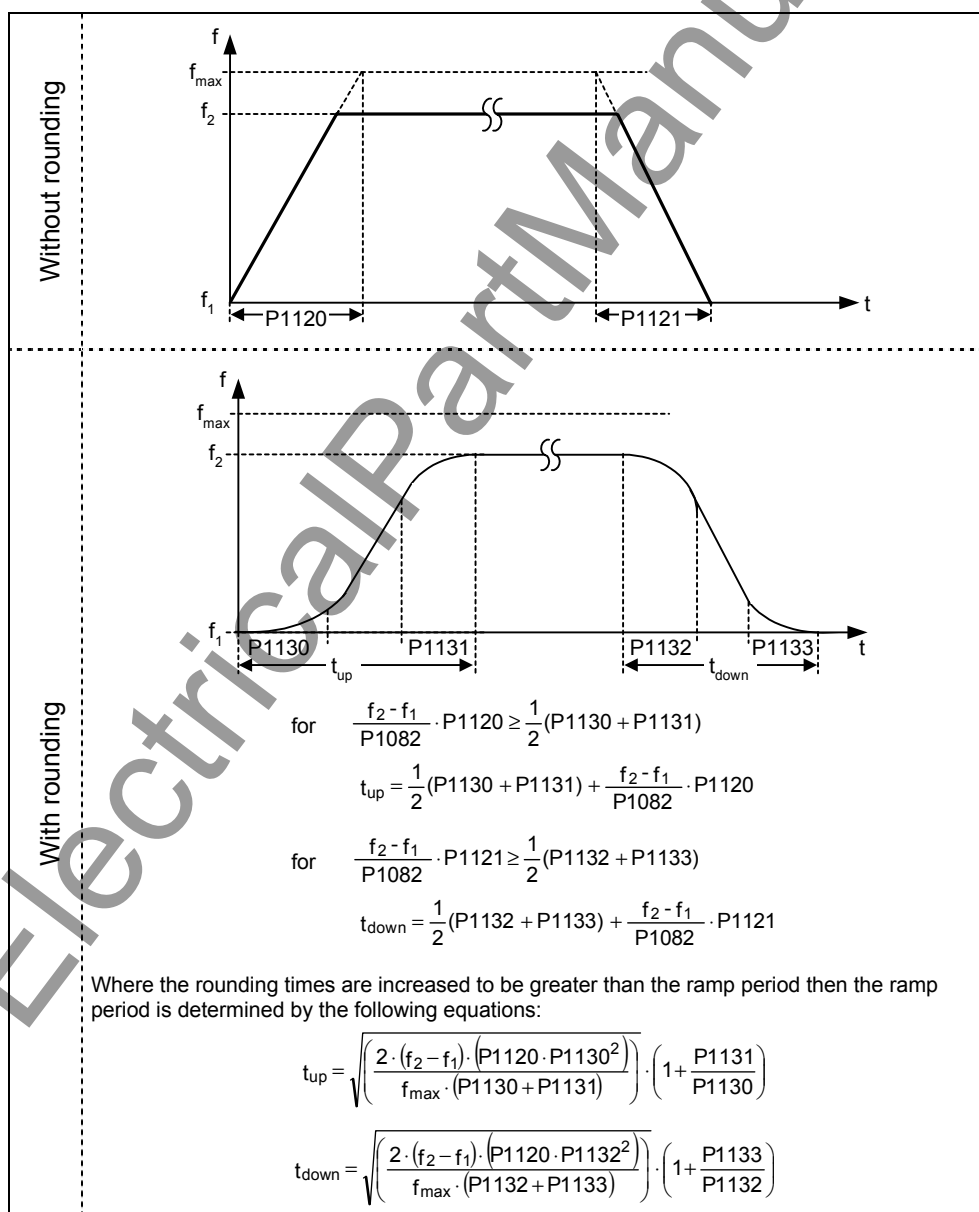


Fig. 3-62 Ramp-function generator

In order to avoid torque surges at the transitions (constant velocity phase  $\longleftrightarrow$  accelerating / braking phase), additional rounding-off times P1130 – P1133 can be programmed. This is especially important for applications (e.g. transporting/pumping liquids or for cranes) which require an especially "soft", jerk-free acceleration and braking.

If the OFF1 command is initiated while the drive is accelerating, then rounding-off can be activated or de-activated using parameter P1134 (refer to Fig. 3-63). These rounding-off times are defined using parameters P1132 and P1133.

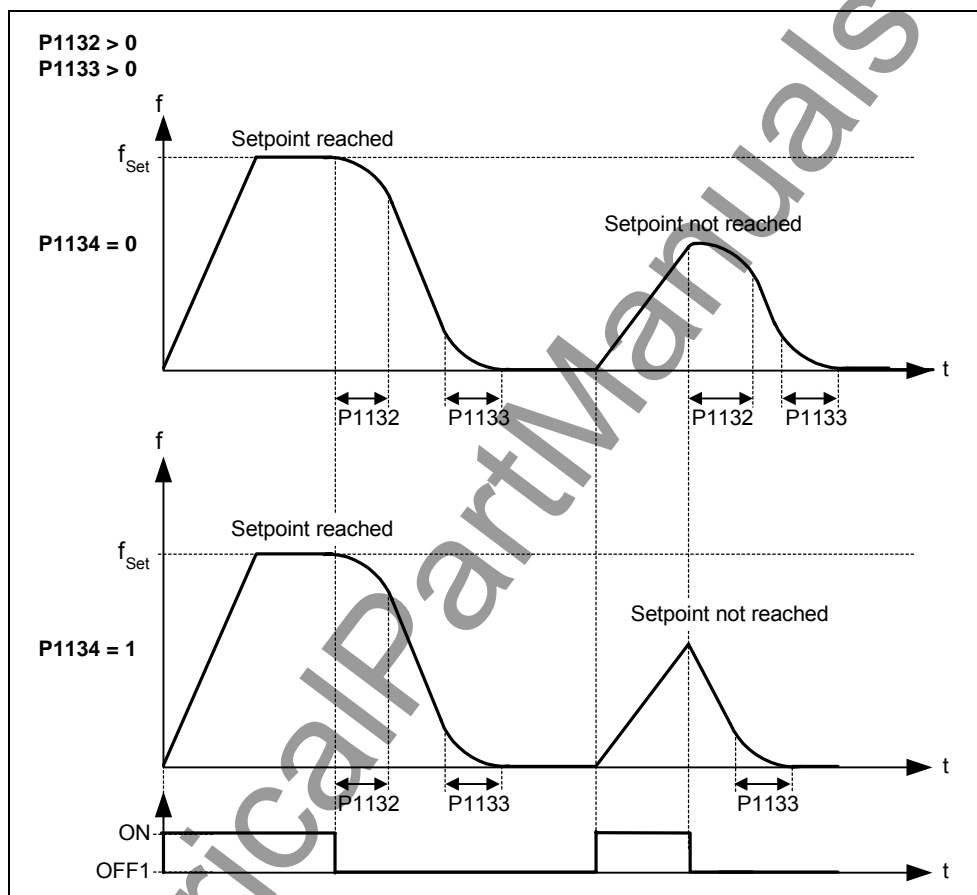


Fig. 3-63 Rounding off after an OFF1 command

In addition to the rounding-off times, the ramp-function generator can be influenced using external signals. The ramp-function generator provides the following functionality using BICO parameters P1140, P1141 and P1142 (refer to Table 3-28).

Table 3-28 BICO parameters for ramp-function generator

Parameter		Description
P1140	BI: RFG enable	The ramp-function generator <u>output</u> is set to 0 if the binary signal = 0.
P1141	BI: RFG start	The ramp-function generator <u>output</u> keeps its actual value if the binary signal = 0.
P1142	BI: RFG enable setpoint	If the binary signal = 0, then the ramp-function generator <u>input</u> is set to 0 and the output is reduced to 0 via the ramp-function generator ramp.

The ramp-function generator itself is enabled after the pulses have been enabled (inverter enable) and after the excitation time has expired (P0346). After limiting to the maximum speeds for the positive and negative directions of rotation (P1082, - P1082 or 0 Hz for the direction of rotation inhibit) the setpoint speed for the control is obtained (r1170).

**NOTE**

The maximum frequency of the setpoint channel is set using parameter P1080.  
 In V/f mode the maximum frequency is 650 Hz.  
 In vector mode the maximum frequency it is limited to 200 Hz (r1084).

### 3.12.3 OFF/braking functions

Parameter range: P1121, P1135, P2167, P2168  
 P0840 – P0849  
 r0052 bit 02

Warnings -  
 Faults -  
 Function chart number: -

The drive inverter and the user must respond to an extremely wide range of situations and stop the drive. In this case, both requirements relating to operations as well as drive inverter protective functions (e.g. electrical and thermal overload) and man-machine protective functions have to be taken into account. As a result of the different OFF/braking functions (OFF1, OFF2, OFF3) MICROMASTER can flexibly respond to the requirements mentioned above.

#### OFF1

The OFF1 command is closely coupled to the ON command. When the ON command is withdrawn, then OFF1 is directly activated. The drive is braked by OFF1 with the ramp-down time P1121. If the output frequency falls below the parameter value P2167 and if the time in P2168 has expired, then the inverter pulses are cancelled.

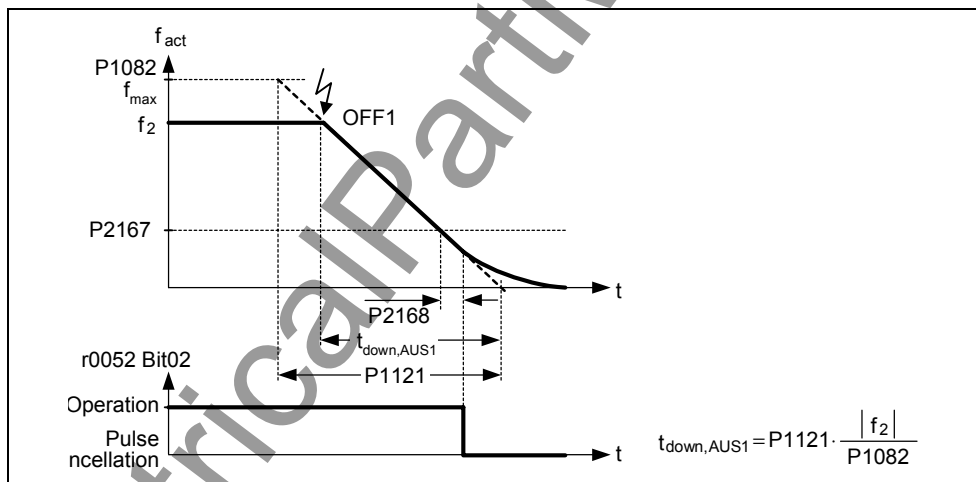


Fig. 3-64 OFF1

**NOTE**

- OFF1 can be entered using a wide range of command sources via BICO parameter P0840 (BI: ON/OFF1) and P0842 (BI: ON/OFF1 with reversing).
- BICO parameter P0840 is pre-assigned by defining the command source using P0700.
- The ON and the following OFF1 command must have the same source.
- If the ON/OFF1 command is set for more than one digital input, then only the digital input that was last set, is valid, e.g. DIN3 is active.
- OFF1 is low active
- When simultaneously selecting the various OFF commands, the following priority applies: OFF2 (highest priority) – OFF3 – OFF1
- OFF1 can be combined with DC current braking or compound braking.
- When the motor holding brake MHB (P1215) is activated, for an OFF1, P2167 and P2168 are not taken into account.

**OFF2**

The inverter pulses are immediately cancelled by the OFF2 command. This means that the motor coasts-down and it is not possible to brake in a controlled fashion.

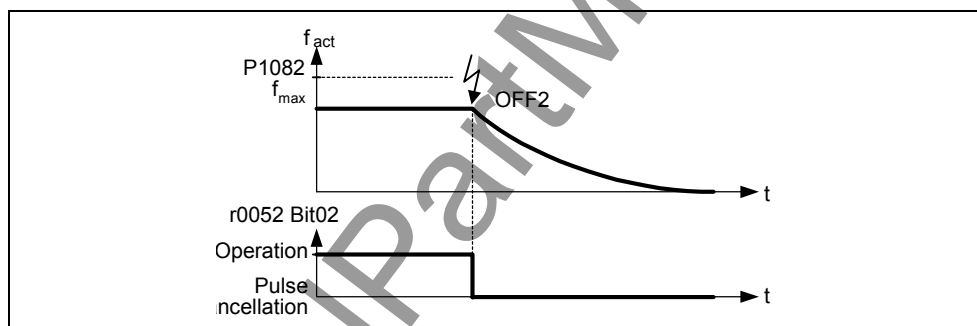


Fig. 3-65 OFF2

**NOTE**

- The OFF2 command can have one or several sources. The command sources are defined using BICO parameters P0844 (BI: 1. OFF2) and P0845 (BI: 2. OFF2).
- As a result of the pre-assignment (default setting), the OFF2 command is set to the BOP. This source is still available even if another command source is defined (e.g. terminal as command source → P0700 = 2 and OFF2 is selected using DIN2 → P0702 = 3).
- OFF2 is low-active
- When simultaneously selecting the various OFF commands, the following priority applies: OFF2 (highest priority) – OFF3 – OFF1

**OFF3**

The braking characteristics of OFF3 are identical with those of OFF1 with the exception of the autonomous OFF3 ramp-down time P1135. If the output frequency falls below parameter value P2167 and if the time in P2168 has expired, then the inverter pulses are cancelled as for the OFF1 command.

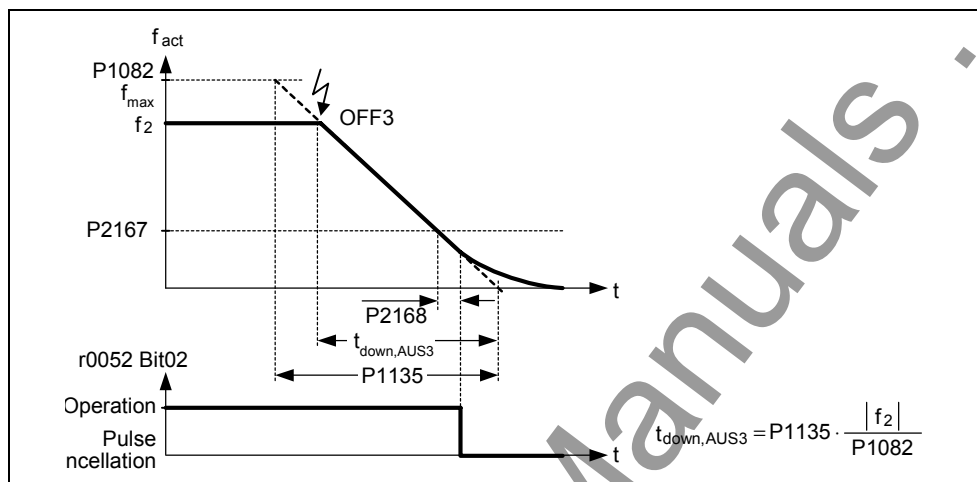


Fig. 3-66 OFF3

**NOTE**

OFF3 can be entered using a wide range of command sources via BICO parameters P0848 (BI: 1. OFF3) and P0849 (BI: 2. OFF3).

- OFF3 is low active
- When simultaneously selecting the various OFF commands, the following priority applies: OFF2 (highest priority) – OFF3 – OFF1

### 3.12.4 Manual / automatic operation

Parameter range: P0700, P1000,  
P0810, P0811

Warnings -

Faults -

Function chart number: -

It is necessary to change-over from the automatic mode into the manual mode to load and unload production machines and to feed new materials (e.g. batch processing). The machine operator carries-out the preparatory activities for subsequent automatic operation in the manual mode. In the manual mode, the machine operator locally controls the machine (enters the ON/OFF command as well as also the setpoint). A changeover is only made into the automatic mode after the set-up has been completed. In the automatic mode, the control (open-loop) of the machines and production processes are handled by a higher-level control system (e.g. PLC). This operation is maintained until it is necessary to again load and unload the machine or feed new material into the machine or production process.

For MICROMASTER 440, indexed parameters P0700 or P1000 and BICO parameters P0810 and P0811 are used to changeover (toggle between) the manual/automatic modes. The command source is defined using P0700 and the setpoint source is defined using P1000 (refer to Table 3-30), whereby index 0 (P0700[0] and P1000[0]) defines the automatic mode and index 1 (P0700[1] and P1000[1]) the manual mode. BICO parameters P0810 and P0811 are used to changeover (toggle between) the automatic and manual modes. These BICO parameters can be controlled from any control source (refer to Table 3-29). In so doing, in addition to P0700 and P1000, also all of the other CDS parameters are changed over (manual/automatic changeover is generalized as a CDS changeover).

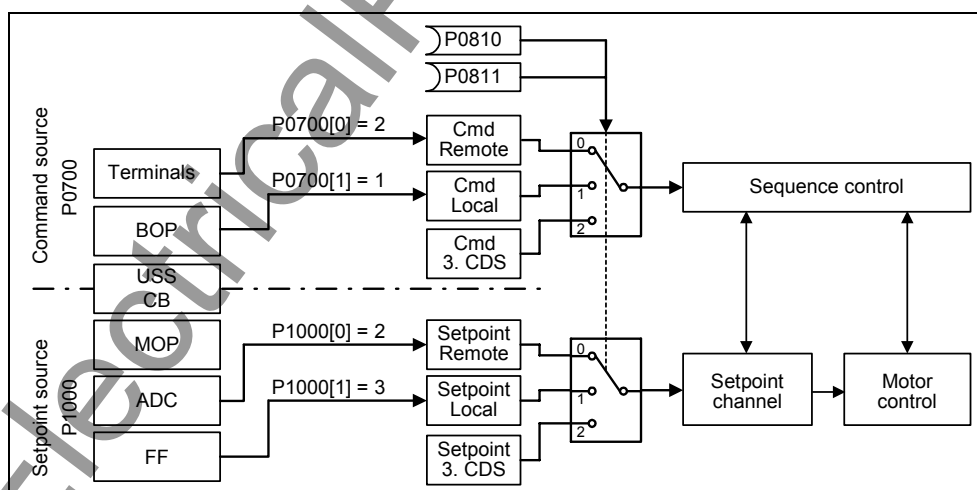


Fig. 3-67 Changing-over using the BICO parameters P0810 and P0811

Table 3-29 Examples for settings of parameter P0810

Parameter setting	Command source
P0810 = 722.2 requires P0703 = 99	Digital input 3
P0810 = 2032.15	USS at the BOP link
P0810 = 2036.15	USS at the COM link
P0810 = 2090.15	CB at the COM link

Table 3-30 Possible settings for parameters P0700 and P1000

Value	Command source (P0700)	Value	Setpoint source (P1000)
1	BOP (keyboard)	1	MOP setpoint
2	Terminal strip	2	Analog setpoint
4	USS at the BOP link	3	Fixed frequency
5	USS at the COM link	4	USS at the BOP link
6	CB at the COM link	5	USS at the COM link
		6	CB at the COM link
		7	Analog setpoint 2
		10	No main setpoint + MOP setpoint
		:	
		77	Analog setpoint 2 + analog setpoint 2

### 3.13 Free function blocks (FFB)

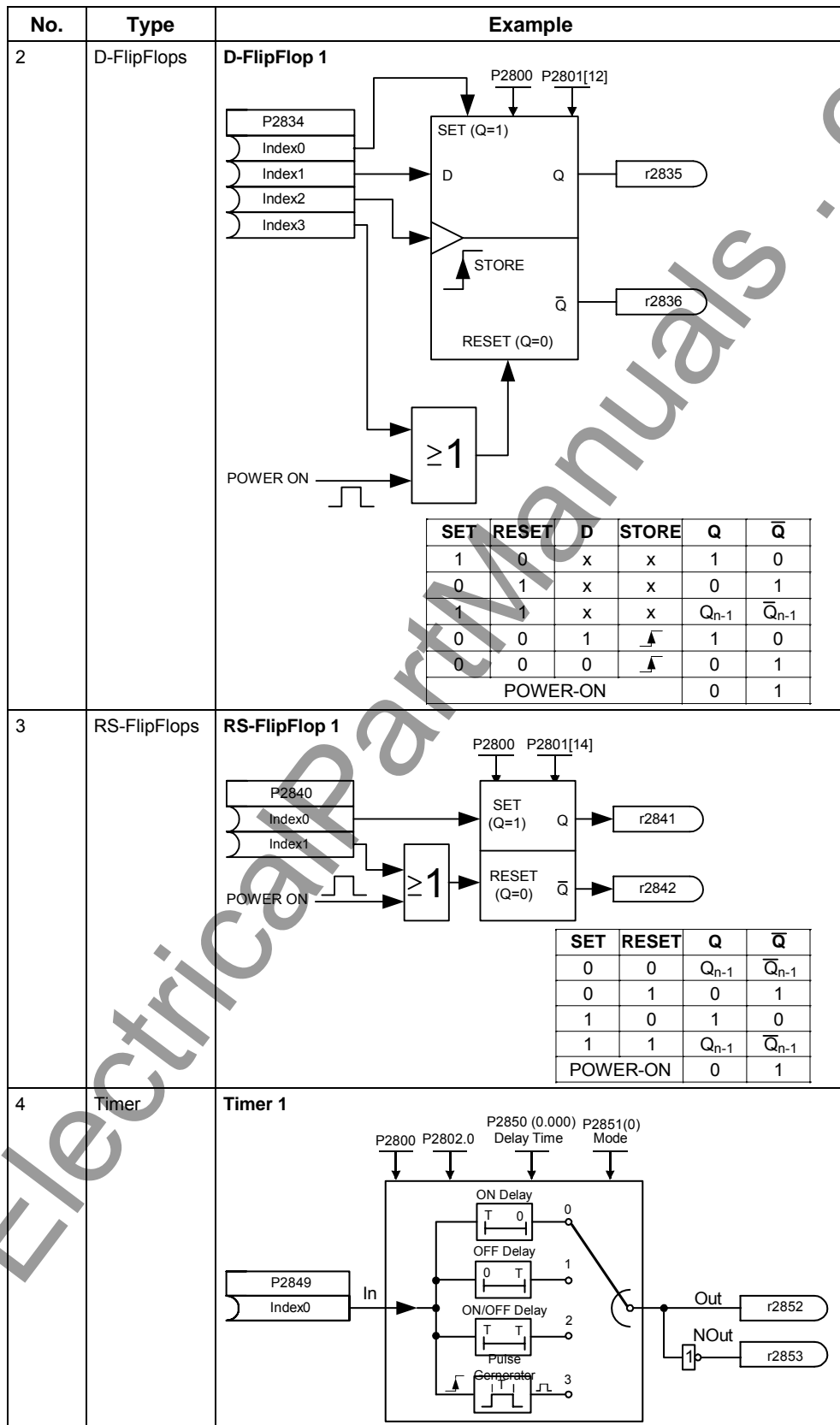
Parameter range: P2800 – P2890  
 Warnings -  
 Faults -  
 Function chart number: FP4800 – FP4830  
 Cycle time: 128 ms

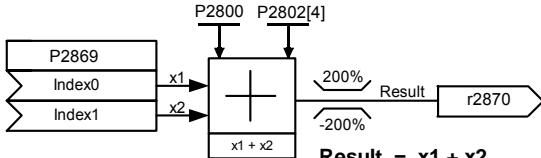
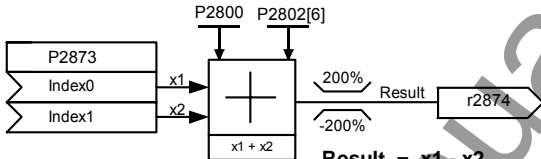
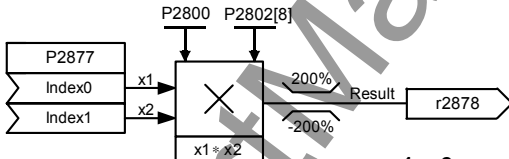
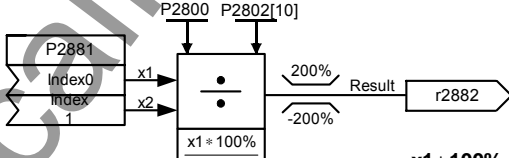
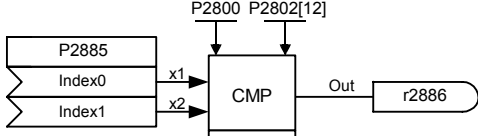
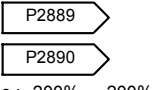
For many applications, interlocking logic is required in order to control (open-loop) the drive inverter. This interlocking logic couples several states (e.g. access control, plant/system state) to form a control signal (e.g. ON command). Previously this was implemented using either a PLC or relays. This represented additional costs for the plant or system. In addition to logic operations, increasingly, arithmetic operations and storage elements are required in drive inverters which generate a new unit from several physical quantities. This simplified PLC functionality is integrated in MICROMASTER 440 using the freely programmable function blocks (FFB).

The following function blocks are integrated in MICROMASTER 440:

Table 3-31 Free function blocks

No.	Type	Example															
3	AND	<p><b>AND 1</b></p> <table border="1"> <thead> <tr> <th>A</th> <th>B</th> <th>C</th> </tr> </thead> <tbody> <tr> <td>0</td> <td>0</td> <td>0</td> </tr> <tr> <td>0</td> <td>1</td> <td>0</td> </tr> <tr> <td>1</td> <td>0</td> <td>0</td> </tr> <tr> <td>1</td> <td>1</td> <td>1</td> </tr> </tbody> </table>	A	B	C	0	0	0	0	1	0	1	0	0	1	1	1
A	B	C															
0	0	0															
0	1	0															
1	0	0															
1	1	1															
3	OR	<p><b>OR 1</b></p> <table border="1"> <thead> <tr> <th>A</th> <th>B</th> <th>C</th> </tr> </thead> <tbody> <tr> <td>0</td> <td>0</td> <td>0</td> </tr> <tr> <td>0</td> <td>1</td> <td>1</td> </tr> <tr> <td>1</td> <td>0</td> <td>1</td> </tr> <tr> <td>1</td> <td>1</td> <td>1</td> </tr> </tbody> </table>	A	B	C	0	0	0	0	1	1	1	0	1	1	1	1
A	B	C															
0	0	0															
0	1	1															
1	0	1															
1	1	1															
3	XOR	<p><b>XOR 1</b></p> <table border="1"> <thead> <tr> <th>A</th> <th>B</th> <th>C</th> </tr> </thead> <tbody> <tr> <td>0</td> <td>0</td> <td>0</td> </tr> <tr> <td>0</td> <td>1</td> <td>1</td> </tr> <tr> <td>1</td> <td>0</td> <td>1</td> </tr> <tr> <td>1</td> <td>1</td> <td>0</td> </tr> </tbody> </table>	A	B	C	0	0	0	0	1	1	1	0	1	1	1	0
A	B	C															
0	0	0															
0	1	1															
1	0	1															
1	1	0															
3	NOT	<p><b>NOT 1</b></p> <table border="1"> <thead> <tr> <th>A</th> <th>C</th> </tr> </thead> <tbody> <tr> <td>0</td> <td>1</td> </tr> <tr> <td>1</td> <td>0</td> </tr> </tbody> </table>	A	C	0	1	1	0									
A	C																
0	1																
1	0																



No.	Type	Example
2	ADD	<p><b>ADD 1</b></p>  <p><b>Result = <math>x1 + x2</math></b></p> <p>If: <math>x1 + x2 &gt; 200\% \rightarrow</math> Result = 200%  <math>x1 + x2 &lt; -200\% \rightarrow</math> Result = -200%</p>
2	SUB	<p><b>SUB 1</b></p>  <p><b>Result = <math>x1 - x2</math></b></p> <p>If: <math>x1 - x2 &gt; 200\% \rightarrow</math> Result = 200%  <math>x1 - x2 &lt; -200\% \rightarrow</math> Result = -200%</p>
2	MUL	<p><b>MUL 1</b></p>  <p><b>Result = <math>\frac{x1 * x2}{100\%}</math></b></p> <p>If: <math>\frac{x1 * x2}{100\%} &gt; 200\% \rightarrow</math> Result = 200%  <math>\frac{x1 * x2}{100\%} &lt; -200\% \rightarrow</math> Result = -200%</p>
2	DIV	<p><b>DIV 1</b></p>  <p><b>Result = <math>\frac{x1 * 100\%}{x2}</math></b></p> <p>If: <math>\frac{x1 * 100\%}{x2} &gt; 200\% \rightarrow</math> Result = 200%  <math>\frac{x1 * 100\%}{x2} &lt; -200\% \rightarrow</math> Result = -200%</p>
2	CMP	<p><b>CMP 1</b></p>  <p><b>Out = <math>x1 \geq x2</math></b></p> <p><math>x1 \geq x2 \rightarrow</math> Out = 1  <math>x1 &lt; x2 \rightarrow</math> Out = 0</p>
2	FFB setpoints (connector settings)	<p>Connector Setting in %</p>  <p>Range : -200% ... 200%</p>



**Example 2:**

Enabling the FFB: P2800 = 1

Enabling individual FFB including assigning a priority:

P2801[3] = 2      OR 1

P2801[4] = 2      OR 2

P2802[3] = 3      Timer 4

P2801[0] = 1      AND 1

The FFB are calculated in the following sequence:

Timer 4, OR 1, OR 2, AND 1

The function blocks are interconnected using BICO technology (refer to Section 3.1.2.3). In so doing, the function blocks can be connected with one another as well as to other signals and quantities as long as these signals / quantities have the appropriate attribute (BO, BI, CO and CI).

### 3.14 Motor holding brake (MHB)

Parameter range: P1215  
 P0346, P1216, P1217, P1080  
 r0052 bit 12

Warnings -  
 Faults -  
 Function chart number: -

For drives which must be secured when powered-down to prevent them undesirably moving, the MICROMASTER brake sequence control (enabled via P1215) can be used to control the motor holding brake.

Before opening the brake, the pulse inhibit must be removed and a current impressed which keeps the drive in that particular position. In this case, the impressed current is defined by the min. frequency P1080. A typical value in this case is the rated motor slip r0330. In order to protect the motor holding brake from continuous damage, the motor may only continue to move after the brake has been released (brake release times lie between 35 ms and 500 ms). This delay must be taken into account in parameter P1216 "Holding brake release delay" (refer to Fig. 3-68).

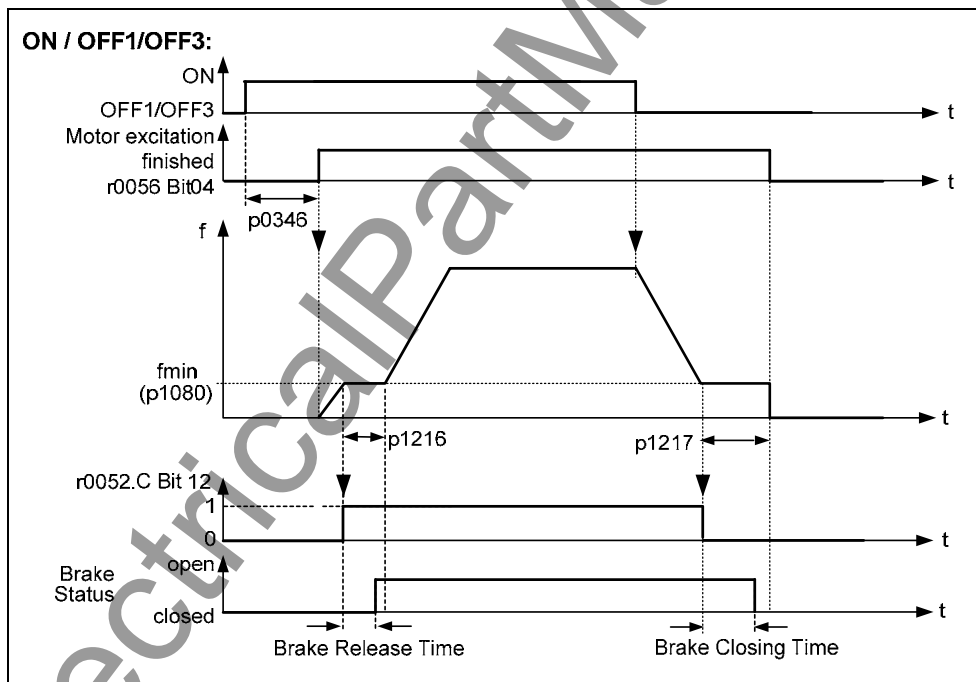


Fig. 3-68 Motor holding brake after ON / OFF1

The motor holding brake is either closed using OFF1 / OFF3 or OFF2. For OFF1 / OFF3, when the minimum frequency P1080 is reached, the motor is operated at this frequency until the brake has been applied (closing times of brakes lie between 15 ms and 300 ms). The actual time is specified using parameter P1217 "Holding time after ramp down" (refer to Fig. 3-68). If, on the other hand, an OFF2 command has been output, then independent of the drive state, the status signal r0052 bit 12 "Motor holding brake active" is reset. This means that the brake immediately closes after OFF2 (refer to Fig. 3-69).

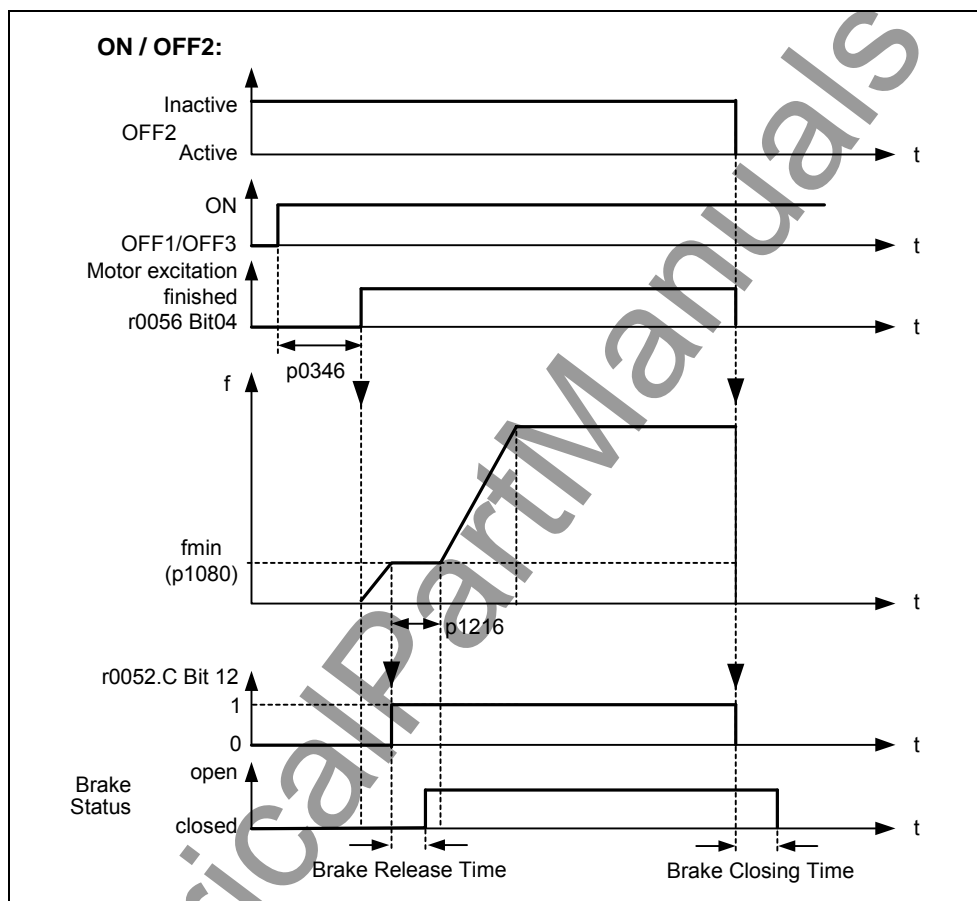


Fig. 3-69 Motor holding brake after OFF2

The mechanical brake is controlled using the status signal r0052 bit 12 "Motor holding brake active" of the brake control. This signal can be output as follows:

- Via digital outputs  
The status signal is output via the digital output. In this case, the internal MICROMASTER relay (if the specification is sufficient) or also an external contactor or relay can be used to control the brake.
- Via status signal using the serial interface (USS or PROFIBUS)  
The master must process the status signal. The signal must be connected to the digital output of the master to which the contactor / relay for the motor holding brake is connected.

**NOTE**

- Motors have optional holding brakes which are not designed to be used as brakes for normal operation. The holding brakes are only designed for a limited number of emergency braking operations / motor revolutions with the brake closed (refer to the Catalog data).
- When commissioning a drive with integrated holding brake it is therefore absolutely imperative that it is ensured that the holding brake functions perfectly. A "clicking noise" in the motor indicates that the brake has been correctly released.
- **Parameter settings:**
  - ◆ To open/close, the digital output controls the motor holding brake at point 1/2 (refer to Fig. 3-68). In this case the prerequisite is that the motor holding brake P1215 has been activated as well as the selection of the motor holding brake at the digital output.
  - ◆ Brake opening time P1216 is greater than/equal to the time to open the holding brake.
  - ◆ Brake delay time P1217 is greater than/equal to the time to close the holding brake.
  - ◆ Select the min. frequency P1080 so that it acts just like a weight equalization function.
  - ◆ A typical value for the min. frequency P1080 for the motor holding brake is the slip frequency of the motor r0330. The rated slip frequency can be calculated using the following formula:
 
$$f_{\text{Slip}}[\text{Hz}] = \frac{r0330}{100} \cdot P0310 = \frac{n_{\text{syn}} - n_n}{n_{\text{syn}}} \cdot f_n$$
  - ◆ The following control parameters should be noted in conjunction with the motor holding brake:
    - for V/f control (open-loop) P1310, P1311, P1333, P1335
    - for closed-loop vector control (SLVC) P1610, P1611, P1750, P1755




---

**WARNING**

- It is not sufficient to select the status signal r0052 bit 12 "Motor holding brake active" in P0731 – P0733. In order to activate the motor holding brake, in addition, parameter P1215 must also be set to 1.
  - If the frequency inverter controls the motor holding brake, then a commissioning may not be carried-out for potentially hazardous loads (e.g. suspended loads for crane applications) unless the load has been secured. Potentially hazardous loads can be secured as follows before commissioning is started:
    - ◆ Lower the load to the floor
    - ◆ During the commissioning phase or after the frequency inverter has been replaced, the frequency inverter must be inhibited from controlling the motor holding brake (it is not permissible that the frequency inverter controls the holding brake). Quick commissioning or a parameter download using STARTER etc. may only be carried-out after this has been absolutely ensured. The motor holding brake terminals can then be re-assigned (in this case, it is not permissible that digital output P0748 is inverted for the motor holding brake).
    - ◆ In order to hold the motor against the mechanical brake at a specific frequency, it is important that the min. frequency P1080 approximately corresponds to the slip frequency. If the value is selected to be too high, then the current drawn can be too high so that the frequency inverter shuts-down (trips) due to an overcurrent. If the value selected is too low, then it is possible that not enough torque is produced to hold the load.
  - It is not permissible to use the motor holding brake as operating brake. The reason for this is that generally it is only dimensioned/designed for a limited number of emergency braking operations.
- 

**Motor with motor holding brake (example)**

A motor with motor holding brake for a hanging (suspended) axis is connected to the frequency inverter. This holding brake is to be controlled using the 1<sup>st</sup> digital output.

**Which settings have to be made?**

- Select the "motor holding brake active" function (52.12) at digital output P0731.
- Activate the brake sequence control in the frequency inverter (P1215 = 1).
- Set parameter P1216 to open the holding brake after an ON command. The brake opening time P1216 must be set so that it is equal to or longer than the time required to open the holding brake. The opening time of the brake (refer to the Motor Catalog, e.g. M11) plus the relay opening time can be used as nominal value for P1216.
- Set parameter P1217 to close the holding brake after an OFF1/3 command. The brake delay time P1217 must be set so that it is equal to or longer than the time required to close the holding brake. The closing time of the brake (refer to Motor Catalog, e.g. M11) plus the relay closing time can be used as nominal value for P1217.
- ◆ **Set the load holding**  
The opening / closing times of mechanical brakes are subject to certain fluctuations; this is the reason that a weight equalization function must be parameterized in the frequency inverter for the time P1216 and P1217. The following parameters must be defined so that the axis cannot sag (i.e. the axis cannot drop/fall).

- ◆ In order that the motor can immediately establish a torque after an ON command, the magnetizing time P0346, determined with the quick commissioning, may not be reset. This is the reason that parameter P0346 should be checked for the weight equalization.

Typical magnetizing times for 4-pole 1LA7 motors are:

0.12 kW	50 ms	7.50 kW	300 ms
1.50 kW	100 ms	55.0 kW	700 ms
5.50 kW	250 ms		

- ◆ The min. frequency P1080 should approximately correspond to the rated motor slip ( $P1080 \approx r0330[\text{Hz}]$ )
- ◆ In addition, the voltage boost should be adapted:
  - V/f mode ( $P1300 = 0 \dots 3$ )
    - constant voltage boost  $P1310 \approx 90\%$  (empirical value)
    - voltage boost when accelerating  $P1311 \approx 50\%$  (empirical value)
  - SLVC mode ( $P1300 = 20$ )
    - constant torque boost  $P1610 \approx 90\%$  (empirical value)
    - torque boost when accelerating  $P1611 \approx 50\%$  (empirical value)

#### ➤ Connecting-up the motor holding brake control

- ◆ Directly connected to the 1<sup>st</sup> relay output

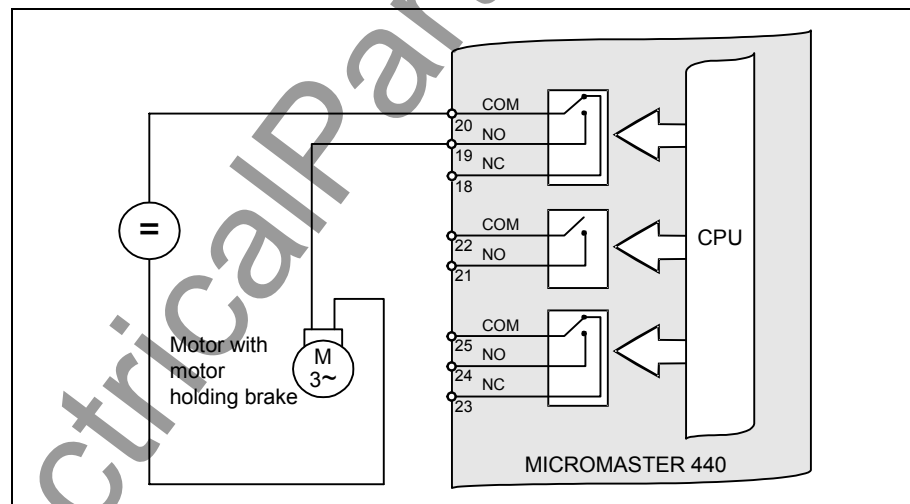


Fig. 3-70 Direct motor holding brake connection

If the frequency inverter directly controls the motor holding brake using the relay integrated in the frequency inverter, then the max. load capability of this relay should be carefully taken into consideration in conjunction with the voltage/current data of the holding brake. The following applies for the relay integrated in the frequency inverter:

- 30 V DC / 5 A
- 250 V AC / 2 A

If this value is exceeded, an additional relay should, for example, be used.

- ◆ Indirectly connecting 1<sup>st</sup> relay output via an additional relay

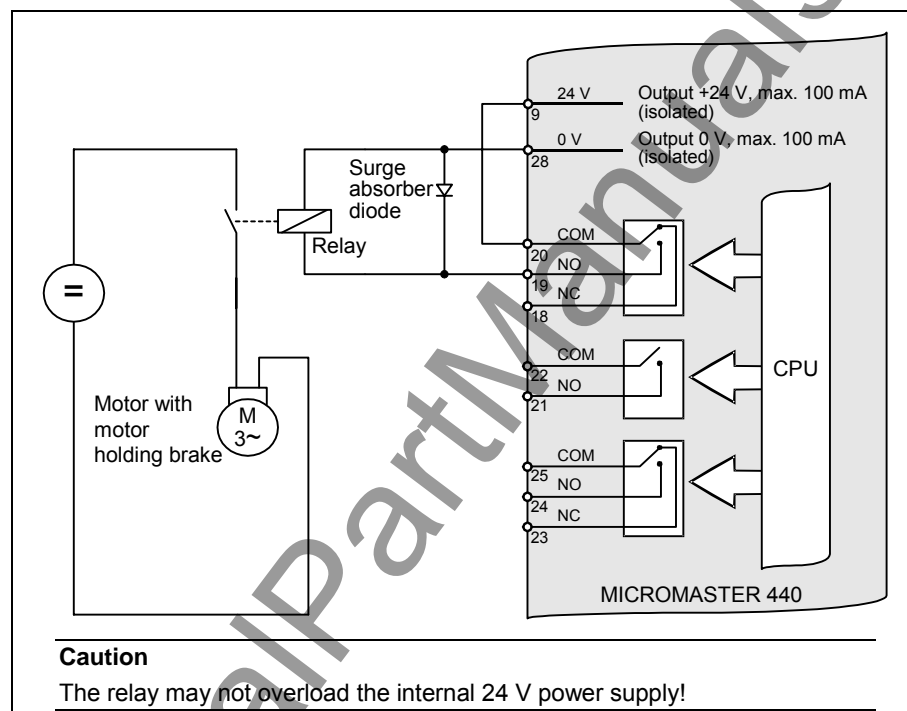


Fig. 3-71 Indirect motor holding brake connection

### Hoisting gear applications

For high loads and low mechanical friction, especially when lowering a load, energy is regenerated that can cause the DC link voltage to increase. This increase can be prevented using dynamic braking (refer to Section 3.15.3; P1237).

In order that there is no negative effect when using dynamic braking, the following functions should be disabled for hoisting gear applications:

- ◆ Vdc\_max controller P1240
- ◆ Compound brake P1236

### 3.15 Electronic brakes

MICROMASTER 440 has 3 electronic brakes:

DC braking (refer to Section 3.15.1)

Compound braking (refer to Section 3.15.2)

Dynamic braking (refer to Section 3.15.3)

These brakes can actively brake the drive and avoid a possible DC link overvoltage condition. An inter-dependency as shown in Fig. 3-72 is present.

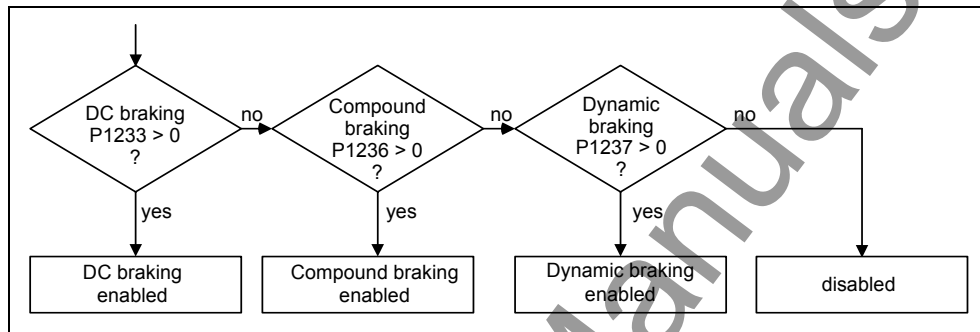


Fig. 3-72 Inter-dependency of the electronic brakes

#### 3.15.1 DC braking

Parameter range: P1230, P1233  
P1232, P1234  
r0053 Bit00

Warnings -

Faults -

Function chart number: -

The drive decelerates along a parameterized braking ramp if an OFF1 / OFF3 command is output. A "flat" ramp must be selected so that the drive inverter is not tripped (shutdown) due to the high regenerative energy which would cause a DC link overvoltage condition. The DC brake should be activated while the OFF1 / OFF3 command is present if the drive is to be braked faster. For DC braking, instead of continually reducing the output frequency / voltage during the OFF1 / OFF3 phase, from a selectable frequency, a DC voltage / current is input (refer to sequence a).

The drive can be brought to a standstill in the shortest time using DC current braking (DC brake). DC braking is selected as follows:

- After OFF1 or OFF3 (the DC brake is released via P1233) Sequence Ⅹ
- Directly selected using BICO parameter P1230 Sequence Ⅲ

For DC braking, a DC current is impressed in the stator winding which results in a significant braking torque for an induction motor. The magnitude, duration and frequency at which braking starts can be set for the braking current and therefore braking torque by setting the appropriate parameters.

The DC brake can therefore support a braking operation from approx. < 10 Hz or prevents / minimizes the increase in the DC link voltage for regenerative braking. This is realized because energy is directly absorbed in the motor. The essential advantage and the main application of the DC brake is the fact that a holding torque can be generated at standstill (0 Hz). For instance, this is important for applications where after positioning, any motion in the mechanical system / product itself can result in waste.

DC braking is especially used for:

- Centrifuges
- Saws
- Grinding machines
- Conveyor belts

### Sequence ✕

1. Enabled using P1233
2. DC braking is activated with the OFF1 or OFF3 command (refer to Fig. 3-73)
3. The drive inverter frequency is ramped-down along the parameterized OFF1 / OFF3 ramp down to the frequency at which DC braking is to start - P1234. This means that the kinetic energy of the motor can be reduced without endangering the drive. However, if the ramp-down time is too short, there is a danger that a fault will be output as a result of an overvoltage condition in DC link - F0002.
4. The inverter pulses are inhibited for the duration of the de-magnetizing time P0347.
5. The required braking current P1233 is then impressed for the selected braking time P1232. The status is displayed using signal r0053 bit 00.

The inverter pulses are inhibited after the braking time has expired.

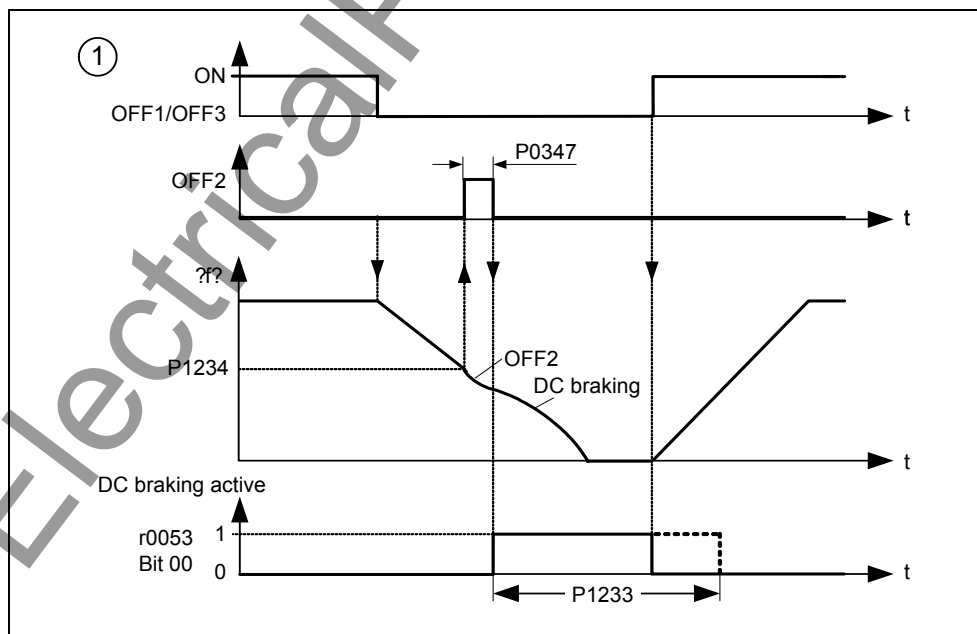


Fig. 3-73 DC braking after OFF1 / OFF3

### Sequence 3

1. Enabled and selected using BICO parameter P1230 (refer to Fig. 3-74)
2. The inverter pulses are inhibited for the duration of the de-magnetizing time P0347.
3. The requested braking current P1232 is impressed for the time selected and the motor is braked. This state is displayed using signal r0053 bit 00.
4. After DC braking has been cancelled, the drive accelerates back to the setpoint frequency until the motor speed matches the drive inverter output frequency. If there is no match, then there is danger that a fault will be output as a result of overcurrent - F0001. This can be avoided by activating the flying restart function.

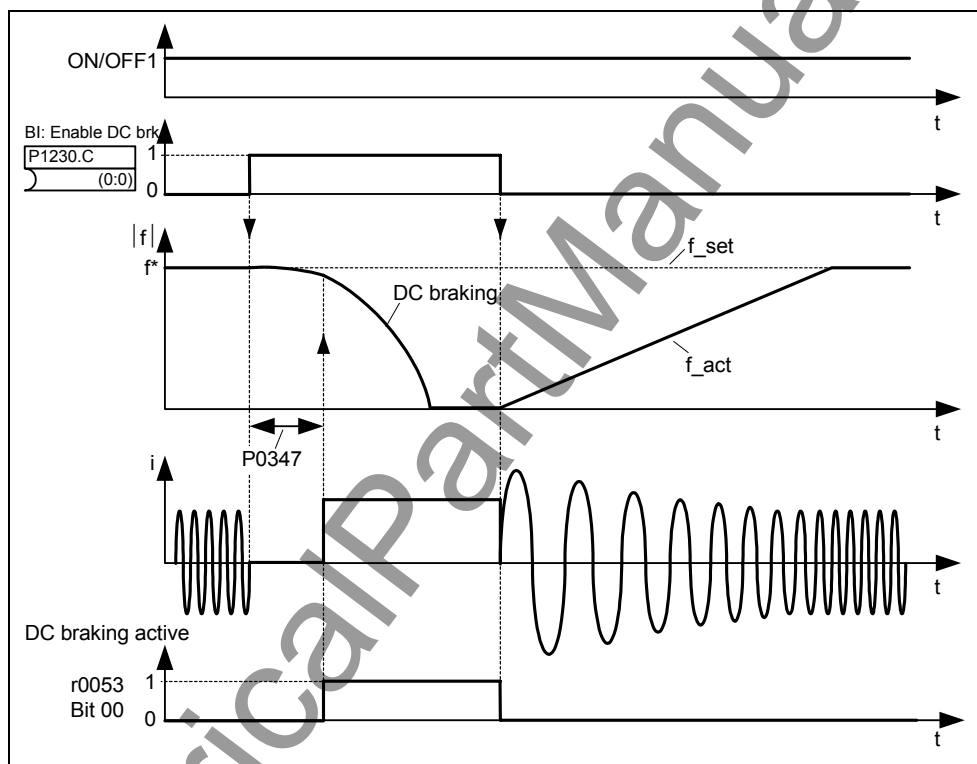


Fig. 3-74 DC braking after external selection

#### NOTE

1. The "DC braking" function is only practical for induction motors !
2. DC braking is not suitable to hold suspended loads !
3. For DC current braking, the motor kinetic energy is converted into thermal energy in the motor. If braking lasts too long, then the drive can overheat !
4. While DC braking, there is no other way of influencing the drive speed using an external control. When parameterizing and setting the drive system, then as far as possible, it should be tested using real loads !

### 3.15.2 Compound braking

Parameter range:	P1236
Warnings	-
Faults	-
Function chart number:	-

For compound braking (this is enabled using P1236) DC braking is superimposed with regenerative braking (where the drive regenerates into the line supply as it brakes along a ramp). If the DC link voltage exceeds the compound switch-in threshold  $V_{DC-Comp}$  (refer to Fig. 3-75), then a DC current is impressed as a function of P1236. In this case, braking is possible with a controlled (closed-loop) motor frequency and minimum regenerative feedback. Effective braking is obtained without having to use additional components by optimizing the ramp-down time (P1121 for OFF1 or when braking from  $f_1$  to  $f_2$ , P1135 for OFF3) and using compound braking P1236.

Compound braking is suitable for:

- Horizontal motion (e.g. traversing drives, conveyor belts)
- Vertical motion (e.g. hoisting gear)

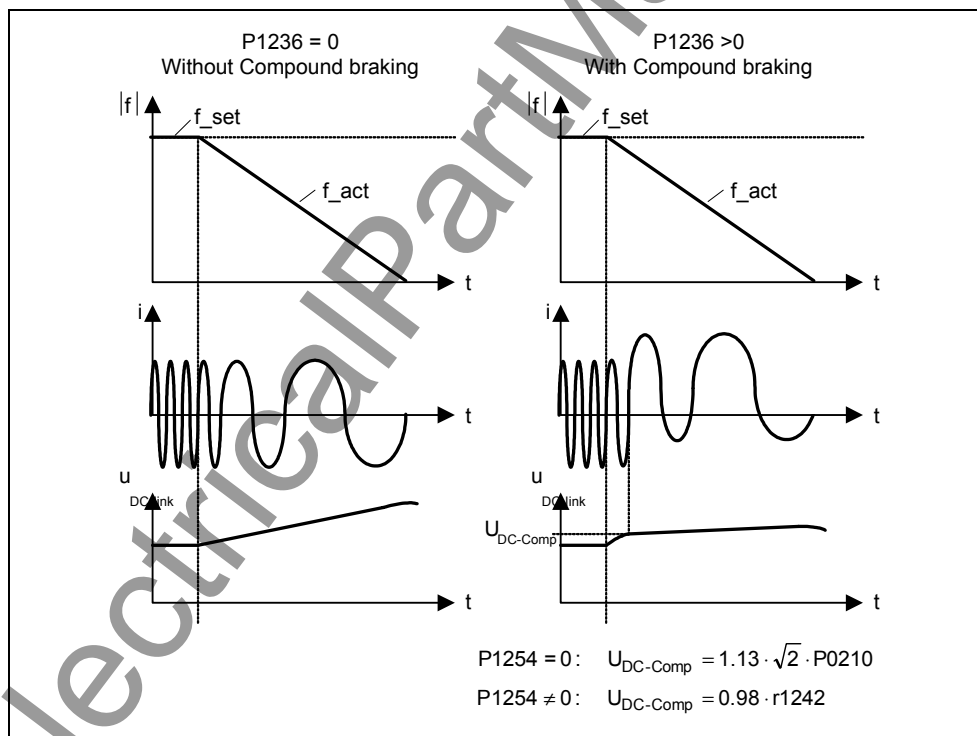


Fig. 3-75 Compound braking

The compound braking switch-in threshold  $V_{DC-Comp}$  is calculated as a function of parameter P1254 (Auto detect  $V_{DC}$  switch-on levels) either directly using the line supply voltage P0210 or indirectly using the DC link voltage and r1242 (refer to the formula in Fig. 3-75).

**WARNING**

- For compound braking, regenerative braking is superimposed on the DC braking (braking along a ramp). This means that components of the kinetic energy of the motor and driven load are converted into thermal energy in the motor. If this power loss is too high or if the braking operation takes too long, then this can cause the drive to overheat !
- When using compound braking it must be expected that there is a higher level of noise above the compound braking switch-in threshold.

**NOTE**

- Only active in conjunction with V/f control.
- Compound braking is de-activated, if
  - flying restart is active,
  - DC braking is active, and
  - Vector control (SLVC, VC) is selected.
- The compound switch-in threshold  $V_{DC-Comp}$  is dependent on P1254
 
$$V_{DC-Comp}(P1254 = 0) \neq V_{DC-Comp}(P1254 \neq 0)$$
  - a) Auto-detect circuit enabled (P1254 = 1):
    - $V_{DC-Comp}(P1254 = 1)$  is automatically calculated when the drive inverter runs-up - i.e. after the line supply voltage has been connected
    - Using the auto-detect function, the  $V_{DC-Comp}$  threshold automatically adapts itself to the line supply voltage at the particular installation location.
  - b) Auto-detect function disabled (P1254 = 0):
    - $U_{DC,Comp} = 1.13 \cdot \sqrt{2} \cdot P0210$
    - The  $V_{DC-Comp}$  threshold is immediately re-calculated after entering P0210
    - P0210 must be adapted to the particular installation location

**3.15.3 Dynamic braking**

Parameter range:	P1237
Warnings	A0535
Faults	F0022
Function chart number:	-

For several drive applications, in certain operating states, the motor can regenerate. Examples of these applications include:

- Cranes
- Traction drives
- Conveyor belts which transport loads downwards

When the motor is in the regenerative mode, the energy from the motor is fed back into the DC link of the drive converter via the inverter. This means that the DC link voltage increases and when the maximum threshold is reached, the drive inverter is shutdown (tripped) with fault F0002. This shutdown (trip) can be avoided by using dynamic braking. Contrary to DC and compound braking, this technique requires that an external braking resistor is installed.

The advantages of dynamic resistor braking include:

- The regenerative energy is not converted into heat in the motor
- It is significantly more dynamic and can be used in all operating states (not only when an OFF command is output)

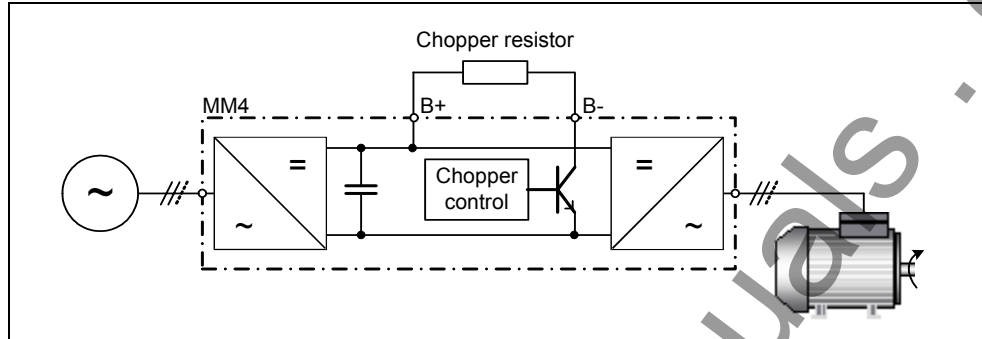


Fig. 3-76 Connecting the chopper (braking) resistor

The braking energy in the DC link is converted into heat when dynamic braking is activated (enabled using P1237). The energy is converted into heat using the voltage-controlled chopper resistor (ballast resistor). Chopper resistors are used if regenerative energy is dissipated in the DC link for a short time, e.g. when a drive brakes and the drive should be prevented from being shutdown (tripped) with fault message F0002 ("DC link overvoltage"). In this case, when the DC link threshold  $V_{DC\ chopper}$  is exceeded, then the chopper resistor is switched-in using an electronic switch (semiconductor switch).

Switch-in threshold of the chopper resistor:

If  $P1254 = 0$  :  $V_{DC, Chopper} = 1.13 \cdot \sqrt{2} \cdot V_{line\ supply} = 1.13 \cdot \sqrt{2} \cdot P0210$

Otherwise :  $V_{DC, Chopper} = 0.98 \cdot r1242$

The chopper switch-in threshold  $V_{DC\ chopper}$  is calculated as a function of parameter P1254 (Auto detect  $V_{DC}$  switch-on levels), either directly using the line supply voltage P0210 or indirectly using the DC link voltage and r1242.

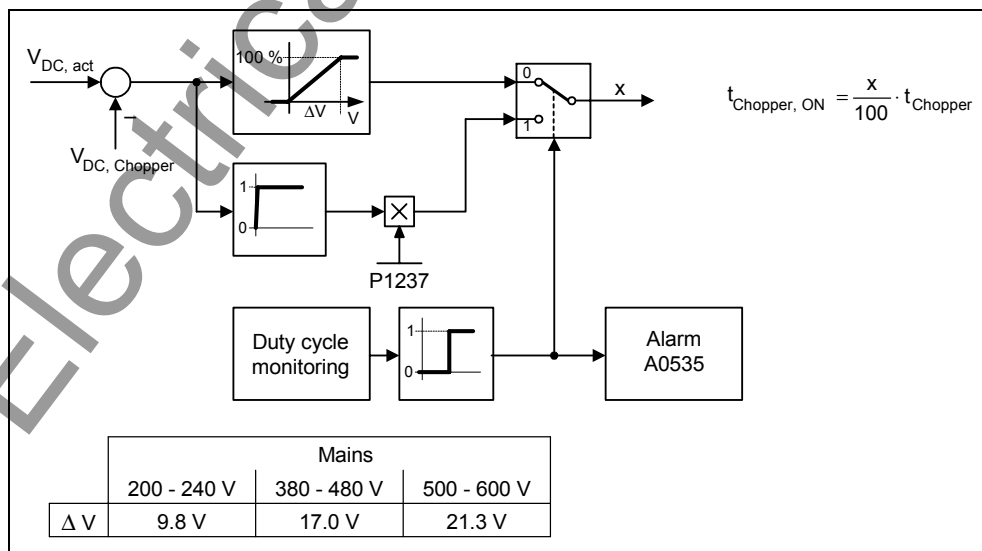


Fig. 3-77 Mode of operation of the dynamic braking

The regenerative (braking) energy is converted into thermal energy using the chopper resistor. A braking module (chopper control) is integrated in the DC link for this purpose. The chopper of the braking module switches the resistor with a mark-space ratio corresponding to the regenerative power to be dissipated. The braking module is only active if, as a result of the regenerative operation, the DC link voltage lies above the chopper switch-in threshold  $V_{DC \text{ chopper}}$ . This means that the braking module is not active in normal operation when motoring.

The chopper resistor is only designed for a specific power and a certain load duty cycle and can only absorb a limited amount of braking energy within a specific time period. The chopper resistors, specified in MICROMASTER Catalog DA51.2, have the following load duty cycle.

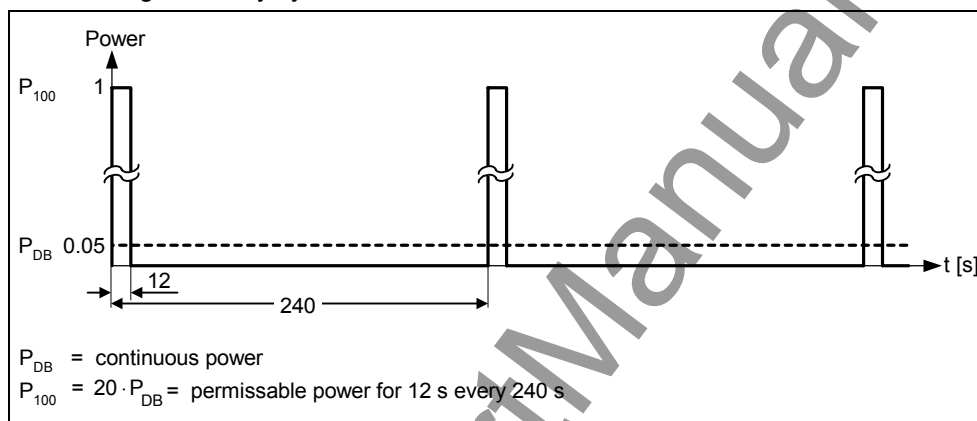


Fig. 3-78 Load duty cycle – chopper resistors (MICROMASTER Catalog DA51.2)

This load duty cycle ( $P1237 = 1 \rightarrow 5\%$ ) is saved in MICROMASTER. If the values are exceeded due to the load required, then when the maximum acceptable braking energy is reached, the load duty cycle monitoring controls the chopper so that the value is reduced to the value entered in parameter P1237. This means that the energy to be dissipated in the chopper resistor is reduced which means that the DC link voltage quickly increases due to the regenerative energy available and the drive inverter is shutdown (tripped) due to a DC link overvoltage condition.

If the continuous power or the load duty cycle for a resistor is too high, then the continuous rating can be quadrupled using 4 resistors in a bridge circuit configuration. In this case, in addition, the load duty cycle must be increased using parameter P1237 from  $P1237 = 1 (\rightarrow 5\%)$  to  $P1237 = 3 (\rightarrow 20\%)$ . When using the bridge circuit, the overtemperature switch of the resistors should be connected in series and incorporated in the fault circuit. This guarantees, that when a resistor overheats, the complete system / drive inverter is shut down.

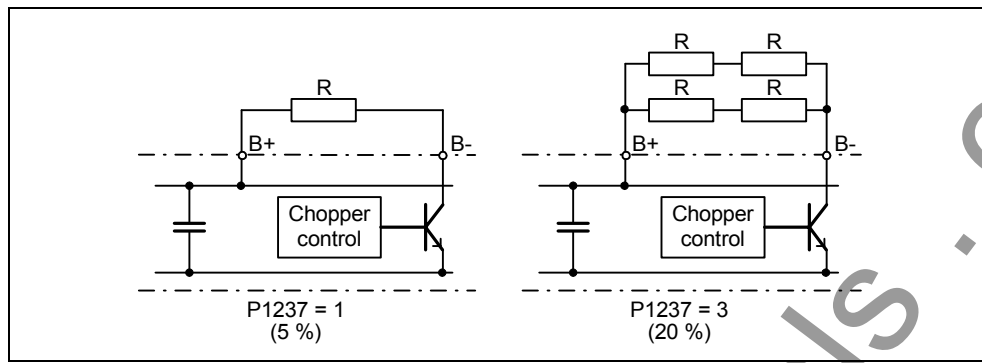


Fig. 3-79 Increasing the level of braking energy which can be absorbed

The continuous power and the load duty cycle are modified using parameter P1237 (setting values, refer to Fig. 3-80a). If the load duty cycle monitoring switches from the peak power (100%) to the continuous power, then this is dissipated for an unlimited length of time in the braking resistor (refer to Fig. 3-80b). Contrary to the braking resistor, as listed in Catalog DA51.2, the chopper control can be permanently operated with 100% power.

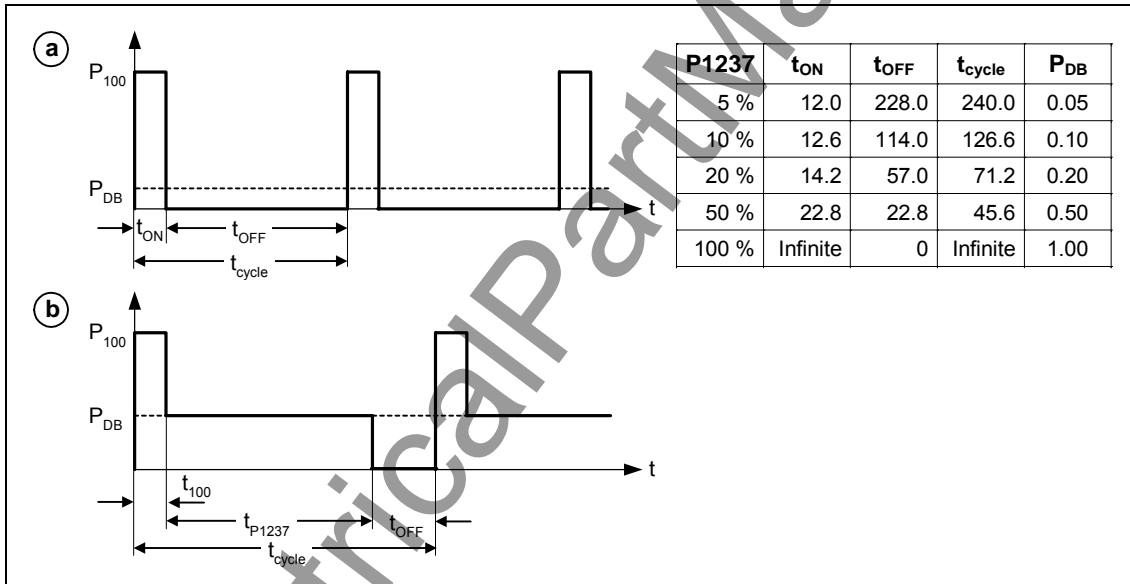


Fig. 3-80 Chopper load duty cycle

For MICROMASTER 440, up to and including Size FS F, the braking module is integrated in the drive inverter and the braking resistor can be connected via external terminals B+, B-.

**NOTE**

- The switch-on threshold  $V_{DC\ chopper}$  of the dynamic resistor braking is dependent on P1254
  - $V_{DC\ chopper}(P1254 = 0) \neq V_{DC\ chopper}(P1254 \neq 0)$ .
  - a) Auto-detect circuit enabled (P1254 = 1):
    - $U_{DC-Chopper}$  (P1254 = 1) is automatically calculated when the drive inverter runs-up - i.e. after the line supply voltage has been connected.
    - Using the auto-detect function, the  $U_{DC-Chopper}$  threshold automatically adapts itself to the line supply voltage at the particular installation location.
  - b) Auto-detect function disabled (P1254 = 0):
    - $U_{DC,Chopper} = 1.13 \cdot \sqrt{2} \cdot P0210$
    - The  $U_{DC-Chopper}$  threshold is immediately re-calculated after entering P0210
    - P0210 must be adapted to the particular installation location
- External braking modules (chopper units) including braking resistor can be used with all of the sizes, FS FX and FS GX. When engineering the system, the particular braking module / resistor must be taken into consideration.

**WARNING**

- Braking resistors, which are to be mounted on MICROMASTER 440, must be designed so that they can tolerate the power dissipated.
- If an unsuitable braking resistor is used there is a danger of fire and that the associated drive inverter will be significantly damaged.
- The chopper control, integrated in the drive converter is designed for the braking resistor value assigned in Catalog DA51.2,
 

e.g.: MICROMASTER 440	6SE6440-2UD23-0BA1
brake resistor	6SE6400-4BD12-0BA0
brake resistor value	160 Ω
- A brake resistor with a lower resistance value will destroy the drive converter. In this case, an external braking unit must be used.
- When operational, the temperature of braking resistors increases – do not touch! Ensure that there is sufficient clearance around the unit and there is adequate ventilation.
- A temperature protection switch must be used to protect the units against overheating.

### 3.16 Automatic restart

Parameter range:	P1210 P1211
Warnings	A0571
Faults	F0035
Function chart number:	-

After a power failure (F0003 "Undervoltage"), the "Automatic restart" function (enabled using P1210) automatically powers-up the drive inverter again. Any faults are automatically acknowledged by the drive inverter.

When it comes to power failures (line supply failure), then a differentiation is made between the following conditions:

#### Line undervoltage (brownout)

"Line undervoltage" is a situation where the line supply is interrupted and returns before (if installed) the BOP display has gone dark (this is an extremely short line supply interruption where the DC link hasn't completely collapsed).

#### Line failure (blackout)

"Line failure" is a situation where the display has gone dark (this represents a longer line supply interruption where the DC link has completely collapsed) before the line supply returns.

The automatic restart function P1210 is shown in the following diagram (refer to Fig. 3-81) as a function of external states / events.

P1210	ON always active (permanent)				ON in no-voltage condition	
	Fault F0003 on Blackout	Fault F0003 on Brownout	All other faults on Blackout	All other faults on Brownout	All faults on Blackout	No faults on Blackout
0	-	-	-	-	-	-
1	Fault acknowl.	-	Fault acknowl.	-	Fault acknowl.	-
2	Fault acknowl. + restart	-	-	-	-	Restart
3	Fault acknowl. + restart	Fault acknowl. + restart	Fault acknowl. + restart	Fault acknowl. + restart	Fault acknowl. + restart	-
4	Fault acknowl. + restart	Fault acknowl. + restart	-	-	-	-
5	Fault acknowl. + restart	-	Fault acknowl. + restart	-	Fault acknowl. + restart	Restart
6	Fault acknowl. + restart	Fault acknowl. + restart	Fault acknowl. + restart	Fault acknowl. + restart	Fault acknowl. + restart	Restart

Fig. 3-81 Automatic restarts

The number of start attempts is specified using parameter P1211. The number is internally decremented after each unsuccessful attempt. After all attempts have been made (as specified in parameter P1211), automatic restart is cancelled with message F0035. After a successful start attempt, the counter is again reset to the initial value.

---

**NOTE**

- The "Flying restart" function (refer to Section 3.17) must be additionally activated if, for an automatic restart, the drive inverter is to be connected to a motor which may already be spinning.



---

**DANGER**

- For longer line supply failures (blackouts) and when the automatic restart function is activated, over a longer period of time it may be assumed that MICROMASTER is powered-down. However, when the line supply returns, motors can automatically start to run again without any operator intervention.
  - If the operating range of the motors is entered in this status, this can result in death, severe injury or material damage.
-

### 3.17 Flying restart

Parameter range: P1200  
P1202, P1203  
r1204, r1205

Warnings -  
Faults -  
Function chart number: -

The "Flying restart" function (this is enabled using P1200, refer to Table 3-33) allows the drive inverter to be switched to a motor which is still spinning. If the drive inverter was to be powered-up without using the flying restart function, there would be a high possibility that a fault with overcurrent F0001 would occur. The reason for this is that the flux must first be established in the motor and the V/f control or closed-loop Vector control must be set corresponding to the actual motor speed. The drive inverter frequency is synchronized with the motor frequency using the flying restart function.

When the drive inverter is normally powered-up it is assumed that the motor is stationary and the drive inverter accelerates the motor from standstill and the speed is ramped-up to the setpoint which has been entered. However, in many cases this condition is not fulfilled. A fan drive is a typical example. When the drive inverter is powered-down the air flowing through the fan can cause it to rotate in any direction.

Parameter P1200	Flying restart active	Search direction
0	Disabled	-
1	Always	Start in the direction of the setpoint
2	For line supply on and fault	Start in the direction of the setpoint
3	For fault and OFF2	Start in the direction of the setpoint
4	Always	Only in the direction of the setpoint
5	For line supply on, fault and OFF2	Only in the direction of the setpoint
6	For fault and OFF2	Only in the direction of the setpoint

Table 3-33 Settings for parameter P1200

#### Flying restart without speed encoder

- a) Depending on parameter P1200, after the de-magnetizing time has expired P0347, flying restart is started with the maximum search frequency  $f_{\text{search,max}}$  (refer to Fig. 3-82).

$$f_{\text{search,max}} = f_{\text{max}} + 2 \cdot f_{\text{slip,standard}} = P1802 + 2 \cdot \frac{r0330}{100} \cdot P0310$$

This is realized either after the line supply returns when the automatic restart function has been activated or after the last shutdown with the OFF2 command (pulse inhibit).

- V/f characteristic (P1300 < 20):

The search frequency is reduced, as a function of the DC link current with the search rate which is calculated from parameter P1203. In so doing, the parameterizable search current P1202 is impressed. If the search frequency is close to the rotor frequency, the DC link current suddenly changes because the flux in the motor establishes itself. Once this state has been reached, the search frequency is kept constant and the output voltage is changed to the voltage value of the V/f characteristic with the magnetizing time P0346 (refer to Fig. 3-82).

- Closed-loop Vector control without encoder (SLVC):  
Starting from the initial value, the search frequency approaches the motor frequency with the impressed current P1202. The motor frequency has been found if both frequencies coincide. The search frequency is then kept constant and the flux setpoint is changed to the rated flux with the magnetizing time constant (dependent on P0346).

After the magnetizing time P0346 has expired, the ramp-function generator is set to the speed actual value and the motor is operated with the actual reference frequency.

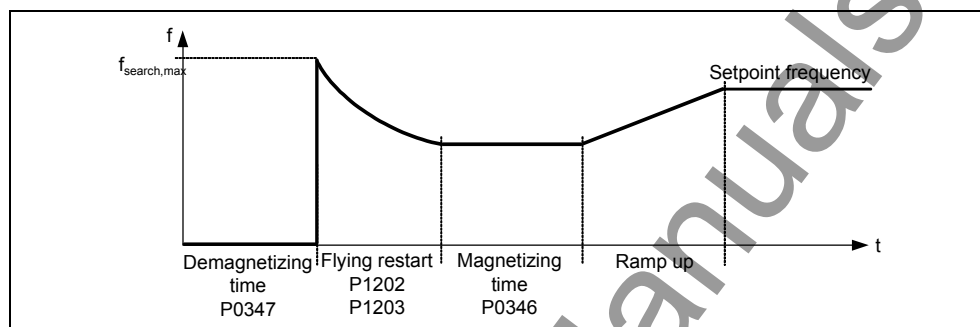


Fig. 3-82 Flying restart

### Flying restart with speed encoder

Depending on parameter P1200, after the de-magnetizing time P0347 expires

- After the line supply returns with the automatic restart active, or
  - After the last shutdown using the OFF2 command (pulse inhibit)
- flying restart is started with the maximum search frequency  $f_{\text{search,max}}$ .

- V/f characteristic (P1300 < 20):  
For V/f control, the output voltage of the drive inverter is linearly increased from 0 to the V/f characteristic value within the magnetizing time P0347.
- Closed-loop Vector control with speed encoder (VC):  
For the closed-loop Vector control, the necessary magnetizing current is established within the magnetizing time P0347.

After the magnetizing time P0346 has expired, the ramp-function generator is set to the speed actual value and the motor is operated at the actual setpoint frequency.

#### NOTE

- If a higher value is entered for the search velocity P1203 this results in a flatter search curve and therefore to an extended search time. A lower value has the opposite effect.
- For "Flying restart", a braking torque is generated which can cause drives, with low moments of inertia, to brake.
- For group drives, "Flying restart" should not be activated due to the different characteristics of the individual motors when coasting down.

#### WARNING

- When "Flying restart" is activated (P1200 > 0), although the drive is at a stand-still and the setpoint is 0, it is possible that the drive is accelerated as a result of the search current !
- If the operating range of the motors is entered when the drive is in this state, this can result in death, severe injury or material damage.



### 3.18 Closed-loop Vdc control

In addition to DC, compound and dynamic braking, for MICROMASTER it is possible to prevent a DC link overvoltage condition using the closed-loop Vdc controller. With this technique, the output frequency is automatically modified during operation using the closed-loop Vdc controller so that the motor doesn't go too far into the regenerative mode.

#### DC link overvoltage

- **Cause:**  
The drive regenerates and feeds too much energy back into the DC link.
- **Remedy:**  
The DC link voltage is further reduced using the Vdc\_max controller (refer to Section 3.18.1) by reducing the regenerative torque down to zero.

Using the Vdc controller, it is also possible to prevent the drive converter being shut down (tripped) during brief line supply dips – which cause a DC link undervoltage condition. Also in this case, the output frequency is automatically modified by the Vdc controller during operation. Contrary to an overvoltage condition, in this case the motor is operated with increased regenerative operation in order to support and buffer the DC link voltage.

#### DC link undervoltage

- **Cause:**  
Line supply voltage failure or dip (blackout or brownout)
- **Remedy:**  
A regenerative torque is entered for the operational drive which compensates the existing losses and therefore stabilizes the voltage in the DC link. This technique is carried-out using the Vdc\_min controller (refer to Section □) and is known as kinetic buffering.

#### 3.18.1 Vdc\_max controller

Parameter range:	P1240, r0056 bit 14 r1242, P1243 P1250 – P1254
Warnings	A0502, A0910
Faults	F0002
Function chart number:	FP4600

A brief regenerative load can be handled using this function (enabled using P1240) without the drive inverter being shut down (tripped) with fault message F0002 ("DC link overvoltage"). In this case, the frequency is controlled (closed-loop) so that the motor doesn't go too far into regenerative operation.

If the drive inverter regenerates too much when braking the machine due to a fast ramp-down time P1121, then the braking ramp / ramp time are automatically extended and the drive inverter is operated at the DC link voltage limit r1242 (refer to Fig. 3-83). If the DC link threshold r1242 is again fallen below, then the Vdc\_max controller withdraws the extension of the braking ramp.

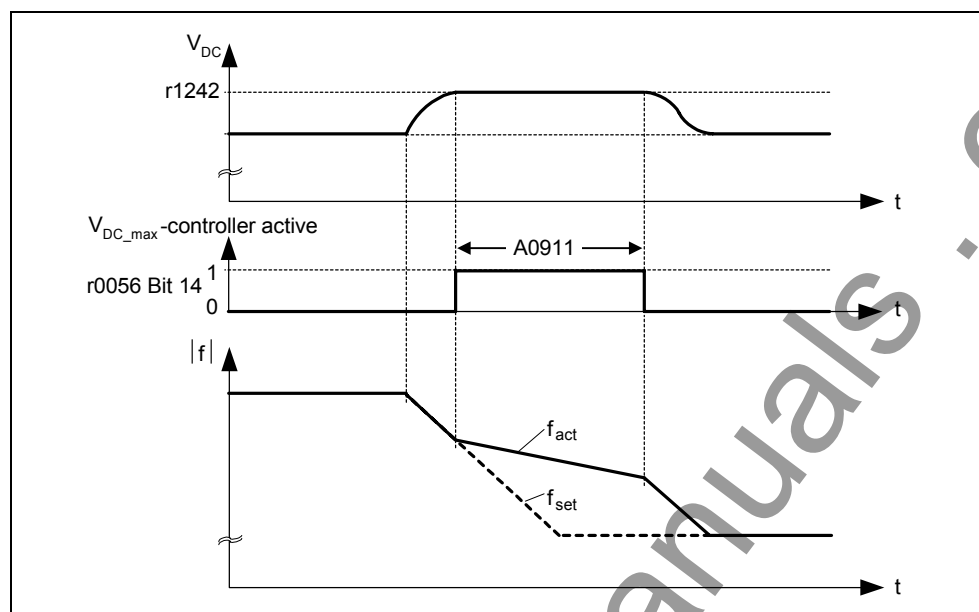


Fig. 3-83 Vdc\_max controller

On the other hand, if the Vdc\_max controller increases the output frequency (e.g. for a steady-state regenerative load), then the Vdc\_max controller is disabled by an internal drive inverter monitoring function and warning A0910 is output. If the regenerative load continues, the drive inverter is protected using fault F0002.

In addition to controlling the DC link (closed-loop), the Vdc\_max controller supports the stabilizing processes of the speed at the end of an acceleration phase. This is especially the case if there is an overshoot and the motor therefore briefly goes into regenerative operation (damping effect).

The automatic increase of the braking ramp (refer to Fig. 3-83) can be contradictory to the objective of the application. This behavior is not required, especially for positioning drives and hoisting gear (e.g. cranes). A DC link overvoltage condition can still be avoided by disabling the Vdc-max controller (P1240 = 0) and by activating the following functions:

- Extending the braking ramp (P1121)
- Activating the compound brake (P1236) or dynamic brake (P1230)

**NOTE**

- 
- If the DC link voltage exceeds the power-on threshold r1242 (switch-on level of Vdc\_max.) of the Vdc\_max controller in the "Ready" state, then the Vdc\_max controller is de-activated and warning A0910 is output.  
Cause: The line supply voltage does not match the application situation.  
Remedy: Refer to parameters P1254 and P0210.
  
  - If, in the "Run" state, the DC link voltage exceeds the power-on threshold r1242 and if the Vdc\_max controller output is limited by parameter P1253 for approx. 200 ms, then the Vdc\_max controller is de-activated and warning A0910 and, where relevant, fault F0002 are output.  
Cause: Line supply voltage P0210 or ramp-down time P1121 too low  
The moment of inertia of the driven load is too high  
Remedy: Refer to parameters P1254, P0210, P1121  
Use a braking resistor
  
  - The Vdc\_max switch-in threshold  $V_{DC\_max}$  depends on P1254  
 $V_{DC\_max}(P1254 = 0) \neq V_{DC\_max}(P1254 \neq 0)$ 
    - a) Auto-detect function enabled (P1254 = 1):
      - $V_{DC\_max}(P1254 = 1)$  is automatically calculated when the drive inverter runs-up, i.e. after the line supply voltage has been connected
      - Using the auto-detect function, the  $V_{DC\_Comp}$  threshold automatically adapts itself to the line supply voltage at the particular installation location.
    - b) Auto-detect function disabled (P1254 = 0):
      - $U_{DC\_max} = 1.15 \cdot \sqrt{2} \cdot P0210$
      - The  $V_{DC\_Comp}$  threshold is immediately re-calculated after entering P0210
      - P0210 must be adapted to the particular installation location.
-

### 3.18.2 Kinetic buffering (Vdc\_min controller)

Parameter range: P1240  
r0056 bit 15  
P1245, r1246, P1247  
P1250 – P1253  
P1256, P1257

Warnings A0503

Faults F0003

Function chart number: FP4600

Brief line supply failures can be buffered using the kinetic buffering function (enabled using P1240). Line supply failures are buffered using the kinetic energy (i.e. moments of inertia) of the driven load. In this case the prerequisite is that the driven load has a sufficiently high flywheel mass or is rotating at an appropriately high speed – i.e. has adequate kinetic or rotating energy.

$$\text{Kinetische Energie: } W_{\text{kin}} = \frac{1}{2}mv^2 \quad \text{Rotationsenergie: } W_{\text{rot}} = \frac{1}{2}J\omega^2$$

Using this technique, the frequency is controlled (closed-loop), so that energy is fed to the drive inverter from the regenerating motor thus covering the system losses. The losses during the line supply failure still remain which means that the motor speed decreases. When using kinetic buffering it has to be taken into consideration that the motor speed reduces.

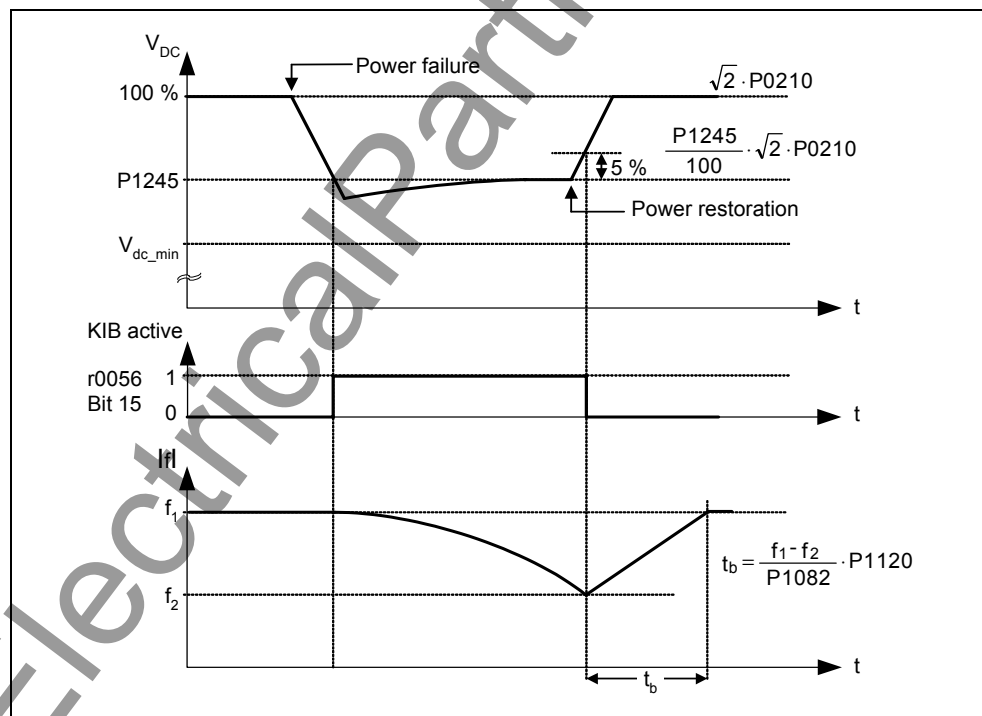


Fig. 3-84 Kinetic buffering (Vdc\_min controller)

When the line supply returns, the energy feed is again from the line side and the output frequency of the drive inverter returns to the selected setpoint along the ramp defined by the ramp-function generator.

**NOTE**

- When the minimum DC link voltage  $V_{DC\_min}$  is fallen below, fault F0003 "Undervoltage" is output and the drive inverter is shut down. The shutdown threshold  $V_{DC\_min}$  depends on the drive inverter type / line supply voltage.

Table 3-34 DC link undervoltage – shutdown threshold

Drive inverter type / line supply voltage	Shutdown threshold $V_{DC\_min}$
1-ph. 200 V – 240 V AC $\pm$ 10 %	215 V
3-ph. 200 V – 240 V AC $\pm$ 10 %	215 V
3-ph. 380 V – 480 V AC $\pm$ 10 %	430 V
3-ph. 500 V – 600 V AC $\pm$ 10 %	530 V

### 3.19 Positioning down ramp

Parameter range: P0500  
P2480 – r2489

Warnings -  
Faults -  
Function chart number: -

The positioning down ramp (enabled using P0500) can be used for applications where it is necessary that a residual distance is moved-through up to the stop dependent on an external event (e.g. BERO switch). In this case, MICROMASTER 440 generates a continuous braking ramp by selecting OFF1 depending on the actual load speed / velocity. The drive is then stopped/positioned along this braking ramp (refer to Fig. 3-85).

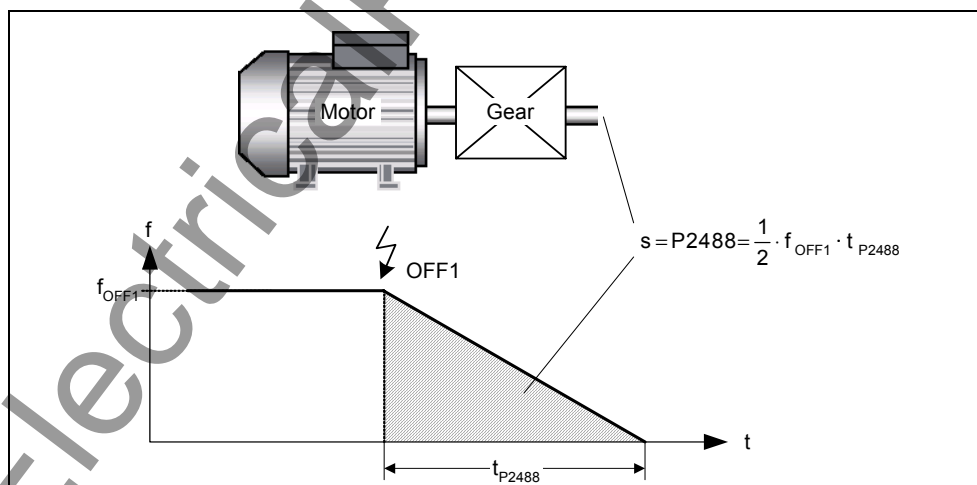


Fig. 3-85 Positioning down ramp

In this case, the remaining distance P2488 moved through must be entered, referred to the load. In order to carry-out the residual distance calculation on the load side, the mechanical arrangement of the axis (gearbox ratio, linear or rotary axis) must be appropriately parameterized (refer to Fig. 3-86).

	Disposition	Parameter
lin		$\dot{U} = \frac{\text{Motor revolutions}}{\text{Load revolutions}} = \frac{P2481}{P2482}$ $z = \text{screw spindle} = \frac{\text{No. of revolutions}}{1 [\text{unit}]} = P2484$
rot		$\dot{U} = \frac{\text{Motor revolutions}}{\text{Load revolutions}} = \frac{P2481}{P2482}$

Fig. 3-86 Rotary or linear axis

Using this data, MICROMASTER 440 calculates the ratio between the distance and the motor revolutions and can therefore consider the movement on the load side.

**NOTE**

- When the positioning down ramp is enabled using parameter P0500 = 3, then implicitly the control mode P1300 is reset as follows as a function of parameter P0205:

a) P0205 = 0 → P1300 = 0

b) P0205 = 1 → P1300 = 2

This change can be undone again after the positioning down ramp has been enabled by modifying parameter P1300.

## 3.20 Monitoring functions / messages

### 3.20.1 General monitoring functions / messages

Parameter range: P2150 – P2180  
r0052, r0053, r2197, r2198

Warnings -

Faults -

Function chart number: FP4100, FP4110

MICROMASTER has an extensive range of monitoring functions / messages which can be used for open-loop process control. The control can either be implemented in the drive inverter or also using an external control (e.g. PLC). The interlocking functions in the drive inverter (refer to Section 3.1.2.3) as well as the output of signals (refer to Section 3.6.2 or 3.7) for external control are implemented using BICO technology.

The status of the individual monitoring functions / messages are emulated in the following CO/BO parameters:

- r0019 CO/BO: BOP control word
- r0050 CO/BO: Active command data set
- r0052 CO/BO: Status word 1
- r0053 CO/BO: Status word 2
- r0054 CO/BO: Control word 1
- r0055 CO/BO: Supplementary (additional) control word
- r0056 CO/BO: Status word – closed-loop motor control
- r0403 CO/BO: Encoder status word
- r0722 CO/BO: Status, digital inputs
- r0747 CO/BO: Status, digital outputs
- r1407 CO/BO: Status 2 – closed-loop motor control
- r2197 CO/BO: Messages 1
- r2198 CO/BO: Messages 2

Frequently used monitoring functions / messages including parameter number and bit are shown in the following Table.

Table 3-35 Partial excerpt of monitoring functions / messages

Functions / states	Parameter / bit number	Function chart
Drive ready	52.0	-
Drive ready to run	52.1	-
Drive running	52.2	-
Drive fault active	52.3	-
OFF2 active	52.4	-
OFF3 active	52.5	-
On inhibit active	52.6	-
Drive warning active	52.7	-
Deviation setpoint – actual value	52.8	-
PZD control	52.9	-
Maximum frequency reached	52.A	-
Warning: Motor current limit	52.B	-
Motor holding brake active	52.C	-
Motor overload	52.D	-
Motor runs right	52.E	-
Drive inverter overload	52.F	-
DC brake active	53.0	-
Ramping finished	53.9	-
PID output R2294 == P2292 (PID_min)	53.A	FP5100
PID output R2294 == P2291 (PID_max)	53.B	FP5100
Download data set 0 from AOP	53.E	-
Download data set 0 from AOP	53.F	-
$ f\_act  > P1080 (f\_min)$	53.2 2197.0	FP4100
$ f\_act  \leq P2155 (f\_1)$	53.5 2197.1	FP4110
$ f\_act  > P2155 (f\_1)$	53.4 2197.2	FP4110
$f\_act > zero$	2197.3	FP4110
$f\_act \geq setpoint (f\_set)$	53.6 2197.4	-
$ f\_act  \geq P2167 (f\_off)$	53.1 2197.5	FP4100
$ f\_act  > P1082 (f\_max)$	2197.6	-
$f\_act == setpoint (f\_set)$	2197.7	FP4110
$i\_act r0068 \geq P2170$	53.3 2197.8	FP4100
Approx. $V_{dc\_act} < P2172$	53.7 2197.9	FP4110
Approx. $V_{dc\_act} > P2172$	53.8 2197.A	FP4110
No-load operation	2197.B	-
$ f\_act  \leq P2157 (f\_2)$	2198.0	-
$ f\_act  > P2157 (f\_2)$	2198.1	-
$ f\_act  \leq P2159 (f\_3)$	2198.2	-
$ f\_act  > P2159 (f\_3)$	2198.3	-
$ f\_set  < P2161 (f\_min\_set)$	2198.4	-
$f\_set > 0$	2198.5	-
Motor blocked	2198.6	-
Motor stalled	2198.7	-
$ i\_act r0068  < P2170$	2198.8	FP4100
$ m\_act  > P2174$ & setpoint reached	2198.9	-
$ m\_act  > P2174$	2198.A	-
Load torque monitoring: Warning	2198.B	-
Load torque monitoring: Fault	2198.C	-

### 3.20.2 Load torque monitoring

Parameter range:	P2181 P2182 – P2192 r2198
Warnings	A0952
Faults	F0452
Function chart number:	-

This function allows the mechanical force transmission between the motor and driven load to be monitored. Typical applications include, for example, pulley belts, flat belts or chains, or pulleys for toothed wheels of drive-in and drive-out shafts which then transmit circumferential velocities and circumferential forces (refer to Fig. 3-87). The load torque monitoring function can then detect whether the driven load is locked or the force transmission has been interrupted.

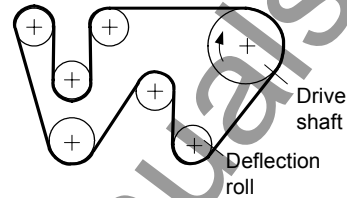


Fig. 3-87 Shaft drive with flat belts

For the load torque monitoring function, the actual frequency/torque characteristic is compared with the programmed frequency/torque characteristic (refer to P2182 – P2190). If the actual value lies outside the programmed tolerance bandwidth, then, depending on parameter P2181, either warning A0952 or fault F0452 is generated. Parameter P2192 can be used to delay the output of the warning or fault message. This avoids erroneous alarms which could be caused by brief transient states (refer to Fig. 3-88).

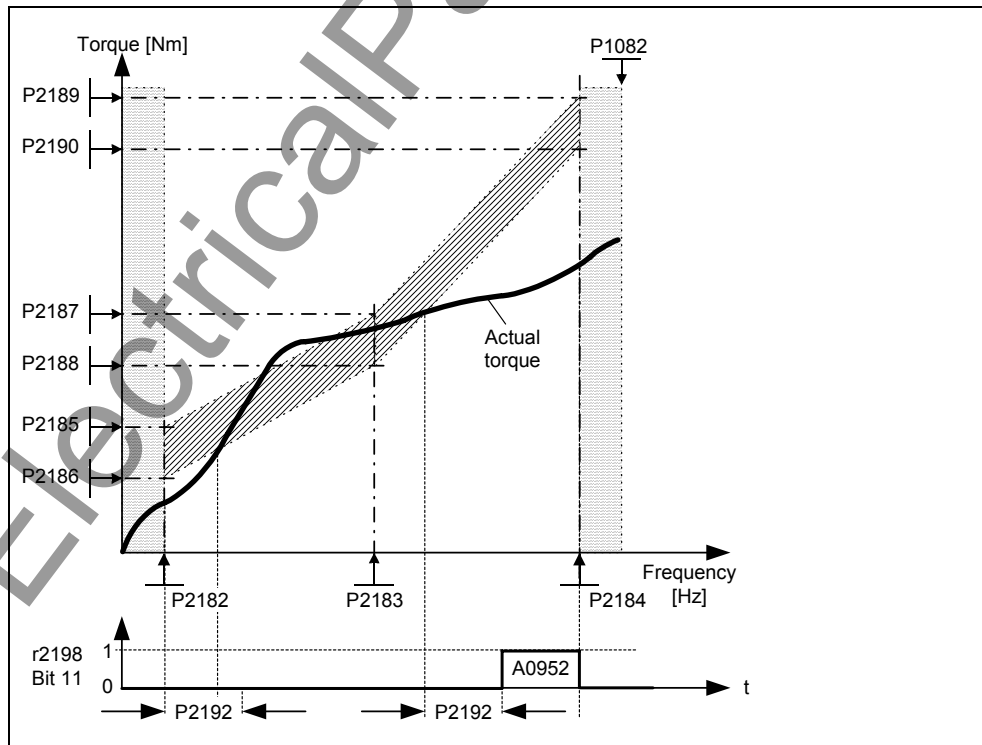


Fig. 3-88 Load torque monitoring (P2181 = 1)

The frequency/torque tolerance bandwidth is defined by the gray shaded area in Fig. 3-89. The bandwidth is determined by the frequency values P2182 – P2184 and the torque limits P2186 – P2189. When defining the tolerance bandwidth it should be ensured that a specific tolerance is taken into account in which the torque values are allowed to vary corresponding to the application.

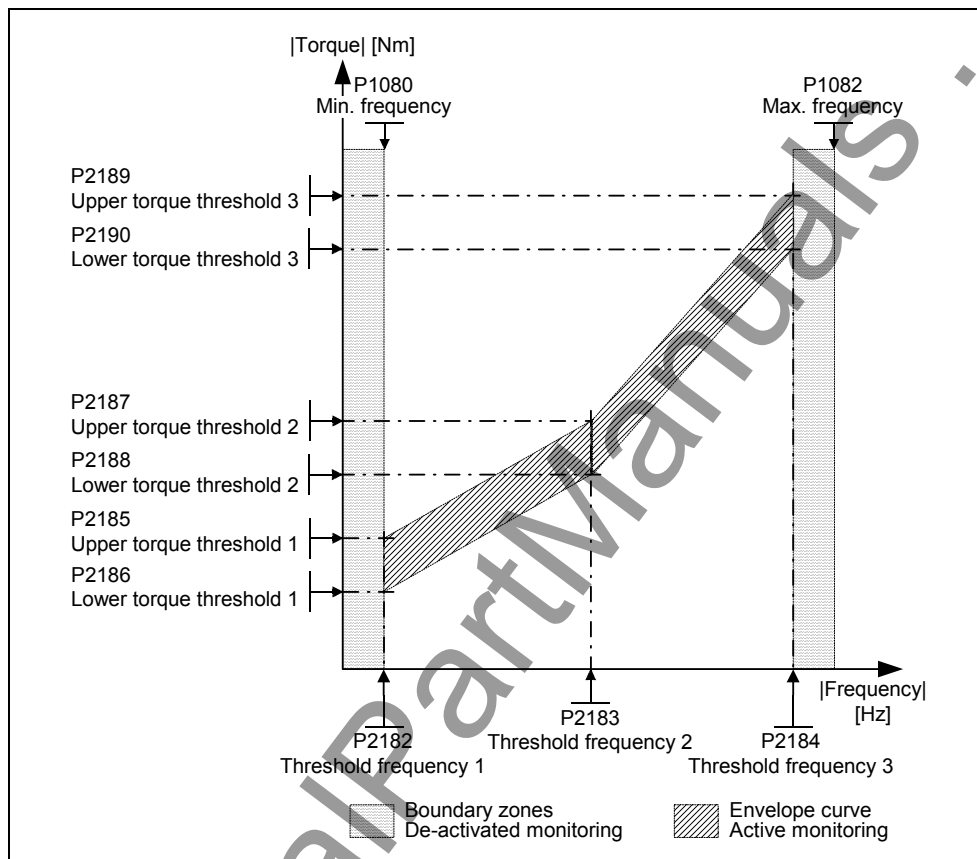


Fig. 3-89 Frequency/torque tolerance bandwidth

### Commissioning steps

1. In order to define the position of the tolerance bandwidth, different characteristics must be determined as a function of the required load torque monitoring (P2181). A differentiation can be made between the following cases:

**a) P181 = 1 / 4**

Load torque monitoring to detect a broken belt, i.e. under fault conditions, the actual load torque is below the permissible tolerance bandwidth. In this case, the load torque characteristic with minimum permissible load should be determined.

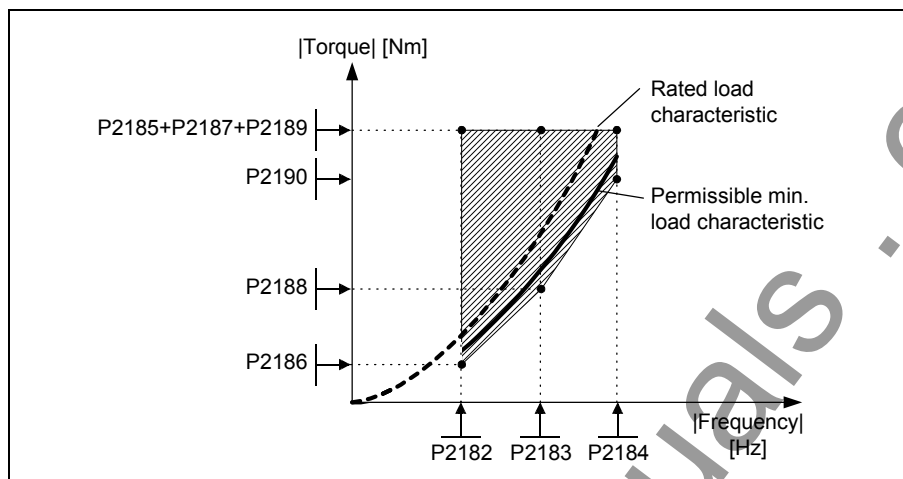


Fig. 3-90 Load torque characteristic with minimum permissible load

**b) P2181 = 2 / 5**

Load torque monitoring as anti-stall protection. This means that when a fault occurs, the actual load torque is above the permissible tolerance bandwidth. In this case, the load torque characteristic with maximum permissible load should be determined.

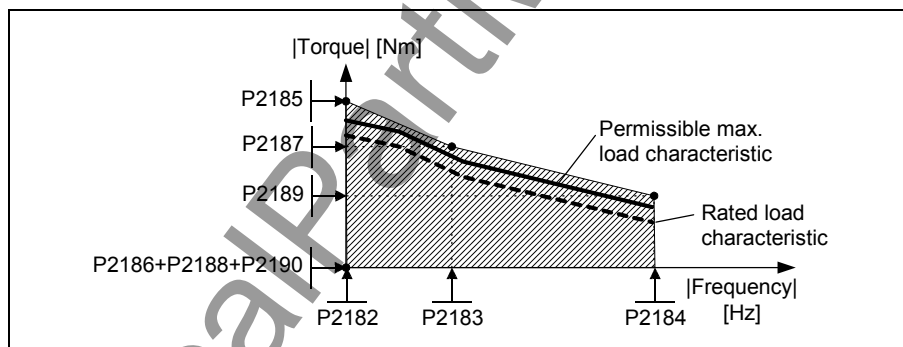


Fig. 3-91 Load torque characteristic with maximum permissible load

**c) P2181 = 3 / 6**

Load torque monitoring to detect whether the drive is blocked (stalled) or a transmission belt has broken. This means that when a fault occurs, the load torque is either above or below the permissible tolerance bandwidth. In this case, the load torque characteristic with the minimum and maximum permissible load should be determined.

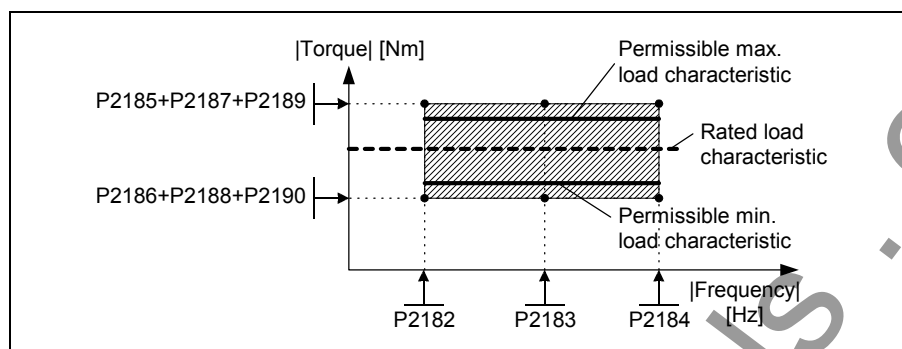


Fig. 3-92 Load torque characteristic with minimum and maximum permissible load

2. The permissible load torque characteristic must be determined in the operating range of the plant or system. This characteristic can be determined as follows:

**a) Theoretical determination**

In this case, the prerequisite is that the load torque characteristic in the operating range must first be known. Frequently, this is not the case in practice. Especially changing mechanical effects involve investigations that require considerable time and costs if they are to be forecast in advance.

**b) Practical determination**

The load torque characteristic is directly determined at the plant/system using a "teach-in technique". In this case, the operating range is passed-through step-by-step and the value pair comprising the actual output frequency r0021 and actual torque r0031 are read-out in the steady-state condition. If necessary, this should be carried-out for both directions of rotation.

3. The position of the tolerance bandwidth (P2182 - P2190) is determined by defining the 3 points along the characteristic.
4. In order to prevent the torque monitoring responding unnecessarily, dynamic states should be suppressed using delay time P2192. As a rule of thumb, P2192 should be > P1120.

**Note**

- The load torque monitoring is active in all 4 quadrants
- If it is not possible to determine the min. or max. load torque characteristic at the drive in operation, then the load torque characteristic should be determined for operation at rated load. By taking into account the tolerances, the max. or min. permissible load characteristic can be calculated (e.g. the max. load characteristic is obtained from the 120% rated load characteristic).
- If only a specific frequency range is to be monitored, then it is sufficient to plot the load characteristic between the frequency thresholds of the envelope curve (P2182, P2184).
- If the drive is only permitted to have one direction of rotation, then the load characteristic should only be determined for the permissible direction of rotation.
- The load characteristic and/or envelope curve determined should be represented in a frequency-torque diagram, e.g. using Microsoft Excel.

### 3.21 Thermal motor protection and overload responses

Parameter range:	P0601 – P0640 P0344 P0350 – P0360 r0035
Warnings	A0511
Faults	F0011, F0015
Function chart number:	-

MICROMASTER 440 has a completely new integrated concept for thermal motor protection. There are numerous possibilities of effectively protecting the motor but at the same time ensuring high motor utilization. The basic philosophy of this innovative concept is to detect critical thermal states, output warnings and initiate the appropriate responses. By responding to critical states it is possible to operate the drive at the thermal power limit and to avoid, under all circumstances, an immediate shutdown (where the drive inverter is tripped).

#### Features

The protective concept (refer to Fig. 3-93) distinguishes itself as a result of the following individual features:

- Protection is effective without using any temperature sensor (P0601 = 0). The temperatures of various locations in the motor are indirectly determined using a temperature model.
- It is possible to evaluate temperature sensors. This has the advantage that after a line supply failure, precise initial temperatures are immediately available. Both PTC sensors (P0601 = 1) as well as KTY84 sensors (P0601 = 2) can be connected and evaluated (refer to Section 3.21.2).
- When using a KTY84 sensor, the drive inverter can be parameterized so that a sensor wire breakage or short-circuit F0015 is detected and the system automatically changes-over to the temperature model. This means that the drive inverter is not shut down (tripped) and operation can continue.
- Selectable temperature warning thresholds P0604 (default: 130 °C) for operation with the temperature model or KTY84 sensor. The drive inverter is shut down or the current reduced depending on P0610 for a value of P0604 +10%.
- Selectable responses P0610 which are to be initiated when the warning threshold is exceeded in order to prevent an overload condition.
- The motor protection has been designed to be completely independent of the drive inverter protection. Warning thresholds and responses for drive inverter protection must be separately parameterized.
- Various data sets are taken into account in the model. The model is separately calculated for each data set so that when changing-over between various motors the cooling of the presently non-active (fed) motors are taken into account.

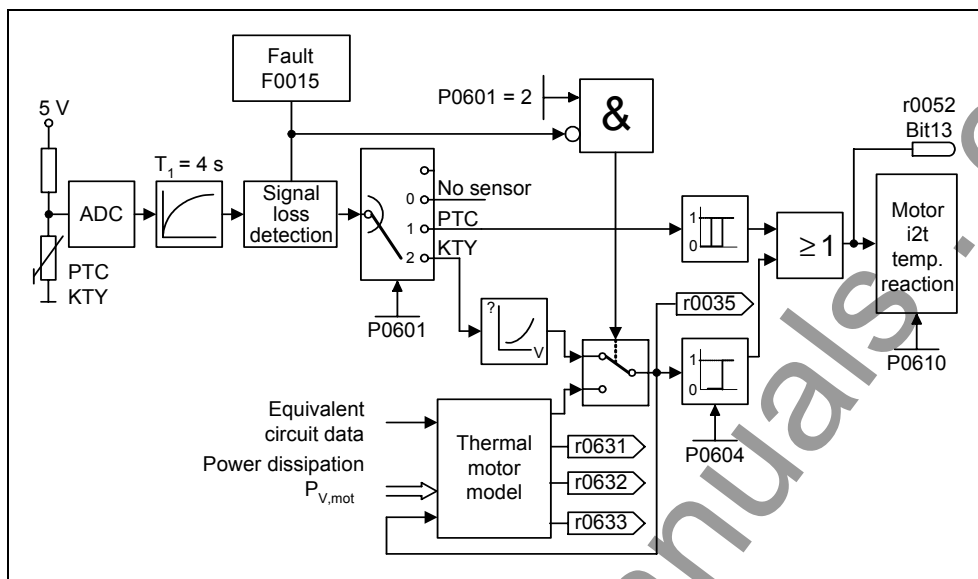


Fig. 3-93 Thermal motor protection

### Temperature rise classes

In drive technology, temperature rise issues play a decisive role when dimensioning electrical machinery. Different temperature limits apply for the various materials used in electric motors. Depending on the insulating material being used, a differentiation is made according to thermal classes (refer to the motor rating plate) with defined limit temperatures. An excerpt from IEC85 is provided in Table 3-36.

Excerpt from IEC 85	
Thermal Class	Max.perm.temperature
Y	90 °C
A	105 °C
E	120 °C
B	130 °C
F	155 °C
H	180 °C

Table 3-36 Thermal classes

For the temperature model or the KTY84 sensor, the appropriate value  $\vartheta_{warn}$  must be calculated and entered into parameter P0604 (temperature warning threshold, default: 130°C). The following applies:

$$P0604 = \vartheta_{warn} = \frac{\vartheta_{trip}}{1.1}$$

### 3.21.1 Thermal motor model

The data, required for the thermal motor model, is estimated from the rating plate data entered during the quick commissioning (refer to Section 3.5.3). This data permits reliable, stable operation for standard Siemens motors. If required, parameter changes must be made for motors from third-party manufacturers. We always recommend that an automatic motor data identification run is made after quick commissioning so that the electrical equivalent circuit diagram data can be determined. This allows a more precise calculation of the losses which occur in the motor which has a positive impact on the accuracy of the thermal motor model.

#### Example:

A stator resistance, which is parameterized to be too high, would result, in the model, to higher losses than in a real motor and an excessively high calculated motor temperature would be displayed.

If changes are required in order to optimize the thermal model, then as a first step, the motor weight (P0344) should be checked for plausibility. Generally, the motor weight is taken from the Catalog data of the motor manufacturer. The thermal model can be further optimized by adapting the standard overtemperatures for the stator iron P0626, the stator winding P0627 and the rotor P0628. The standard overtemperatures represent the steady-state temperatures to be expected in rated operation with respect to the environment and are used to estimate the thermal resistances. Generally, these overtemperatures are not listed in the Catalog.

The ambient temperature P0625 is another important parameter which influences the precision of the thermal model.

---

#### NOTE

- In addition to the thermal motor protection, the motor temperature is also included in the adaptation of the motor equivalent circuit diagram data. This adaptation has a significant influence on the degree of stability of the closed-loop vector control – especially for a high thermal motor load.
  - When switching-in the line supply voltage (i.e. powering-up), depending on whether a KTY sensor is being used or not, the motor temperature model is either initialized with the ambient temperature P0625 – saved in the frequency inverter – or with the actual motor temperature.
  - If the frequency inverter is continually supplied with an external 24 V voltage, then the motor temperature is tracked/corrected using the motor temperature time constant – even when the line supply voltage is shutdown (powered-down).
  - For closed-loop vector control, a high thermal motor load and if the line supply voltage is frequently switched-out/switched-in, then the following is required
    - ◆ a KTY84 sensor should be used, or
    - ◆ an external 24 V power supply should be connected
-

### 3.21.2 Temperature sensor

When the motor is operated below the rated speed the cooling effect of the shaft-mounted fan is reduced. As a result, for most motors when continually operated at lower frequencies, the power has to be reduced. Under these conditions, motor protection against overheating can only be guaranteed if either a temperature sensor (PTC or KTY84 sensor) is integrated in the motor and is connected to the control terminals 14 and 15 of the MICROMASTER 440 (refer to Fig. 3-94) or the motor temperature model was determined (refer to Section 3.21.1).

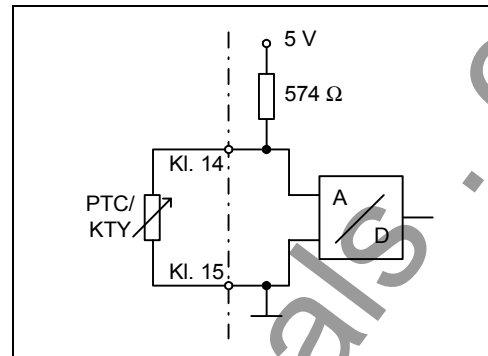


Fig. 3-94 Connecting a temperature sensor to MICROMASTER

#### NOTE

In order to avoid EMC noise from being coupled-in to the drive converter electronics – and the associated disturbances – it is not permissible to use free conductors in the motor cable to connect the temperature sensor to the drive converter.

The temperature sensor must be connected to the drive converter using a separate cable (if at all possible, this cable should be shielded).

**With PTC temperature sensor (P0601 = 1)**

The PTC is connected to the control terminals 14 and 15 of the MICROMASTER 440. PTC monitoring is activated with the parameter setting P0601 = 1. If the resistance value, connected at the terminals, is less than 1500 Ω, then neither alarm nor fault is generated. If this value is exceeded, the drive inverter outputs alarm A0511 and fault F0011. The resistance value where the alarm and fault are output does not lie below 1000 Ω and not above 2000 Ω.

Response thresholds: 4.0 V 0 → 1  
 3.8 V 1 → 0

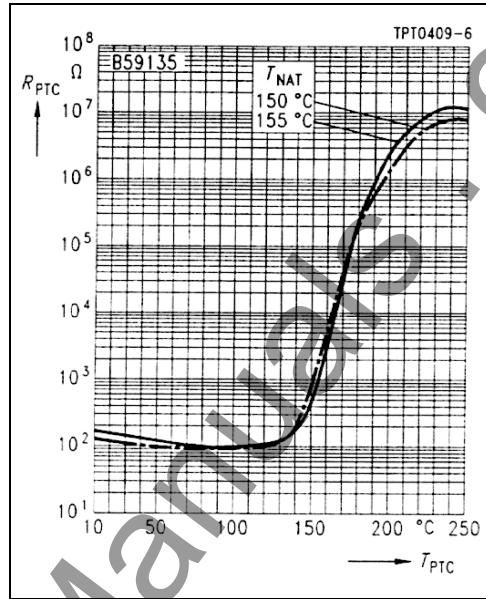


Fig. 3-95 PTC characteristic for 1LG / 1LA motors

**With KTY84 temperature sensor (P0601 = 2)**

The KTY84 must be connected so that the diode is in the conductive direction. This means that the anode is connected to terminal 14 and the cathode to terminal 15. If the temperature monitoring function is activated with the setting P0601 = 2, the temperature of the sensor (i.e. of the motor windings) is written into parameter r0035 (refer to Fig. 3-93). The threshold temperature  $\vartheta_{trip}$  (refer to Table 3-36) of the motor can now be set using the warning threshold, motor overtemperature  $\vartheta_{warn}$  (parameter P0604) (the factory setting is 130 °C). The following applies:

$$P0604 = \vartheta_{warn} = \frac{\vartheta_{trip}}{1.1}$$

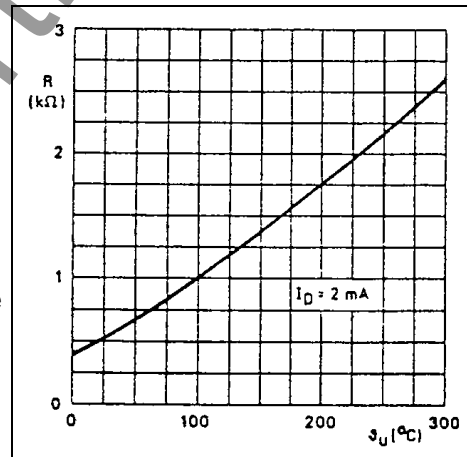


Fig. 3-96 KTY84 characteristic for 1LG / 1LA motors

**Wire breakage or short-circuit**

If the circuit between the drive inverter and PTC or KTY84 sensor is interrupted or there is a short-circuit, the drive inverter is shut down (tripped) and fault F0015 is displayed.

## 3.22 Power module protection

### 3.22.1 General overload monitoring

Parameter range: P0640, r0067, r1242, P0210  
 Warnings A0501, A0502, A0503  
 Faults F0001, F0002, F0003, F0020  
 Function chart number: -

Just the same as for motor protection, MICROMASTER provides extensive protection for the power components. This protection concept is also sub-divided into 2 levels:

- Warning and response
- Fault and shutdown

Using this concept, a high utilization of the power module components can be achieved without the drive inverter being immediately shut down. The power module components are monitored as follows:

Table 3-37 General protection of the power components

	Warning and response	Fault and shutdown
Overcurrent / short circuit	Imax controller for V/f A0501 r0056 bit 09 r0056 bit 13 (refer to Section 3.23.1.2) Current controller for SLVC / VC --- r0056 bit 09 r1407 bit 08 r1407 bit 09	F0001
DC link overvoltage	Vdc_max controller A0502 (refer to Section 3.18.1)	F0002
DC link undervoltage	Vdc_min controller A0503 (refer to Section □)	F0003
Line phase failure detection (refer to P0291)	---	F0020

The monitoring thresholds for the righthand column in the table above are permanently saved in the drive inverter and cannot be changed by the user. On the other hand, the threshold levels for the "Warning and response" column can be modified by the user to optimize the system. These values have default settings so that the "Fault and shutdown" thresholds do not respond.

### 3.22.2 Thermal monitoring functions and overload responses

Parameter range:	P0290 – P0294 r0036 – r0037
Warnings	A0504, A0505
Faults	F0004, F0005, F0012, F0020, F0022
Function chart number:	-

Similar to motor protection, the main function of the thermal power module monitoring is to detect critical states. Parameterizable responses are provided to the user which allows the drive system to be still operated at the power limit thus avoiding immediate shutdown. However, the possibilities of assigning parameters only involves interventions below the shutdown threshold which cannot be changed by users.

MICROMASTER 440 has the following thermal monitoring functions:

➤  **$i^2t$  monitoring**

The  $i^2t$  monitoring is used to protect components which have a long thermal time constant in comparison to the semiconductors. An overload with reference to  $i^2t$  is present if the drive inverter utilization r0036 indicates a value greater than 100 % (utilization as a % referred to rated operation).

➤ **Heatsink temperature**

The monitoring of the heatsink temperature r0037[0] of the power semiconductor (IGBT).

➤ **Chip temperature**

Significant temperature differences can occur between the barrier junction of the IGBT and the heatsink. These differences are taken into account by the chip temperature r0037[1] and monitored.

When an overload occurs regarding one of these three monitoring functions, initially, a warning is output. The warning threshold P0294 ( $i^2t$  monitoring) and P0292 (heatsink temperature and chip temperature monitoring) can be parameterized relative to the shutdown values.

**Example**

The warning threshold P0292 for the temperature monitoring (chip / heatsink temperature) is set to 15 °C in the factory. This means that warning A0504 is output 15 °C below the shutdown threshold.

At the same time that the warning is output, the parameterized responses are initiated via P0290. Possible responses include:

➤ **Reducing the pulse frequency (P0290 = 2, 3)**

This is an extremely effective method to reduce losses in the power module, as the switching losses represent a very high proportion of the overall losses. In many applications, a temporary reduction of the pulse frequency can be tolerated in favor of maintaining the process.

**Disadvantage**

The current ripple is increased when the pulse frequency is reduced. This can result in an increase of the torque ripple at the motor shaft (for low moments of inertia) and an increase in the noise level. When the pulse frequency is reduced this has no influence on the dynamic response of the current control loop as the current control sampling time remains constant !

**➤ Reducing the output frequency (P0290 = 0,2)**

This is advantageous if it is not desirable to reduce the pulse frequency or if the pulse frequency is already set to the lowest level. Further, the load should have a characteristic similar to that of a fan, i.e. a square-law torque characteristic for decreasing speed. When the output frequency is reduced, this significantly reduces the drive inverter output current and in turn reduces the losses in the power module.

**➤ No reduction (P0290 = 1)**

This option should be selected if neither a reduction in the pulse frequency nor a reduction in the output current is being considered. In this case, the drive inverter does not change its operating point after the warning threshold has been exceeded so that the drive can be further operated until the shutdown values are reached. After the shutdown threshold has been reached, the drive inverter shuts down (trips) with fault F0004. The time which expires up to shutdown is however not defined and depends on the magnitude of the overload. Only the warning threshold can be changed in order to obtain an earlier warning and, if required, externally intervene in the drive process (e.g. by reducing the load, lowering the ambient temperature).

**NOTE**

- If the drive inverter fan fails, this would be indirectly detected by the measurement of the heatsink temperature.
- A wire breakage or short circuit of the temperature sensor(s) is also monitored.

### 3.23 Open-loop/closed-loop control technique

There are several open-loop/closed-loop techniques for closed-loop speed and torque control for drive inverters with induction and synchronous motors. These techniques can be roughly classified as follows:

- V/f characteristic control (briefly: V/f control)
- Field-orientated closed-loop control technique (briefly: Vector control)

The field-orientated control technique – also known as Vector control – can be further sub-divided into two groups:

- Vector control without speed feedback (sensorless Vector control (SLVC))
- Vector control with speed feedback (Vector control (VC))

These techniques differ from one another both regarding the control quantity as also in the complexity of the technique, which in turn are obtained as a result of the requirements associated with the particular application. For basic applications (e.g. pumps and fans), to a large extent, V/f control is used. Vector control is mainly used for sophisticated applications (e.g. winders), where a good control and behavior in noisy conditions are required regarding the speed and torque. If these requirements are also present in the range from 0 to approx. 1 Hz, then the speed/torque accuracy without encoder is not sufficient. In this case, Vector control with speed feedback must be used.

#### 3.23.1 V/f control

Parameter range: P1300  
P1310 – P1350

Warnings -

Faults -

Function chart number: FP6100

The V/f characteristic represents the simplest control technique. In this case the stator voltage of the induction motor or synchronous motor is controlled proportionally to the stator frequency. This technique has proven itself for a wide range of "basic" applications, such as

- Pumps, fans
- Belt drives

and similar processes.

The goal of V/f control is to keep the flux  $\Phi$  constant in the motor. In this case, this is proportional to the magnetizing current  $I_{\mu}$  and the ratio between voltage V and frequency f.

$$\Phi \sim I_{\mu} \sim V/f$$

The torque M, developed by induction motors, is proportional to the product (precisely the Vectorial product  $\underline{\Phi} \times \underline{I}$ ) of flux and current.

$$M \sim \Phi * I$$

In order to generate the highest possible torque from a given current, the motor must operate with a constant flux which is as high as possible. In order to keep the flux  $\Phi$  constant, when frequency f changes, the voltage V must be changed in proportion so that a constant magnetizing current  $I_{\mu}$  flows. The V/f characteristic control is derived from these basic principles.

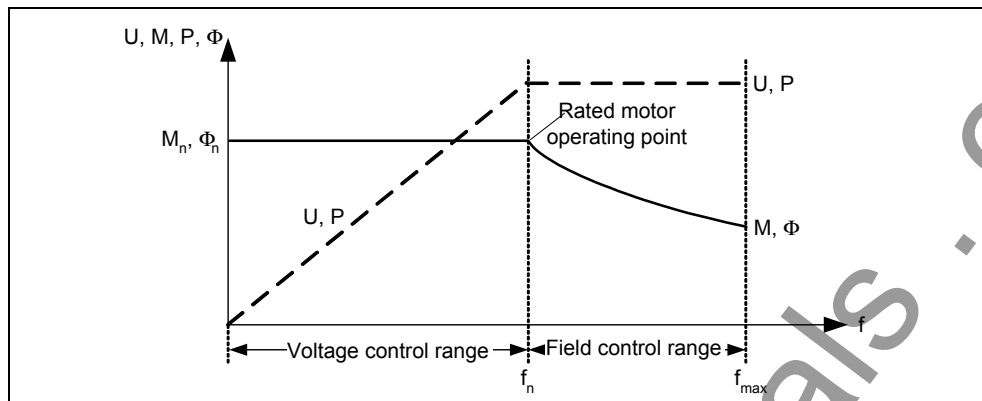
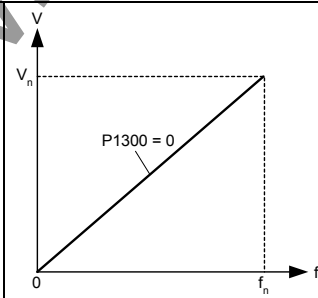
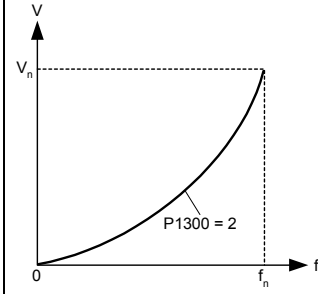
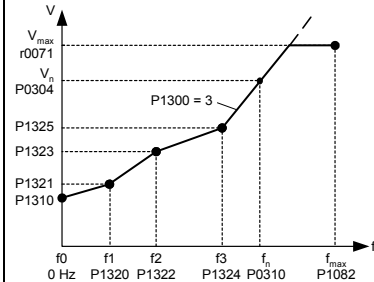


Fig. 3-97 Operating ranges and characteristics of an induction motor when fed from a drive inverter

There are several versions of the V/f characteristic as shown in Table 3-38.

Table 3-38 V/f characteristic (parameter P1300)

Parameter value	Significance	Use / property
0	Linear characteristic	Standard case 
1	FCC	Characteristic which compensates the voltage losses of the stator resistance for static (steady-state) or dynamic loads (flux current control FCC). This is especially used for small motors which have a relatively high stator resistance.
2	Square-law characteristic	This is a characteristic which takes into consideration the torque characteristic of the driven load (e.g. fan / pump) a) Square-law characteristic ( $f^2$ characteristic) b) Energy saving as the lower voltage also results in lower currents and losses. 
3	Programmable characteristic	Characteristic which takes into consideration the torque characteristic of the motor / driven load (e.g. synchronous motor). 

5	Application adaptation	This is a characteristic which takes into consideration the special technological issues of an application (e.g. textile applications), a) Where the current limiting (I <sub>max</sub> controller) only influences the output voltage and not the output frequency, and b) By inhibiting the slip compensation
6	Application adaptation with FCC	This is a characteristic which takes into consideration the special technological issues of an application (e.g. textile applications), a) Where the current limiting (I <sub>max</sub> controller) only influences the output voltage and not the output frequency, and b) By inhibiting the slip compensation
19	Independent voltage input	The user can enter the output voltage of the drive inverter, independently of the frequency, using a BICO parameter P1330 via the interfaces (e.g. analog input → P1330 = 755).

### 3.23.1.1 Voltage boost

Parameter range: P1310, P1311, P1312  
r0056 bit 05

Warnings -

Faults -

Function chart number: FP6100

For low output frequencies, the V/f characteristics only output a low output voltage. Even at low frequencies, the ohmic resistances of the stator winding play a role, which are neglected when determining the motor flux in Section 3.23.1. This means that the output voltage can be too low in order to

- implement the magnetization of an induction motor,
- to hold the load
- to compensate voltage drops (ohmic losses in the winding resistances) in the system or
- to provide a breakaway / accelerating / braking torque.

The output voltage can be increased (boosted) in MICROMASTER using the following parameters (refer to Table 3-39):

Table 3-39 Voltage boost

Parameter	Voltage boost	Explanation
P1310	Constant voltage boost	<p>The voltage boost is effective over the complete frequency range whereby the value continually decreases at high frequencies.</p>
P1311	Voltage boost when accelerating- / braking	<p>The voltage boost is only effective when accelerating or braking.</p>
P1312	Voltage boost when starting	<p>The voltage boost is only effective when accelerating for the first time (standstill).</p>

**NOTE**

- Especially at low frequencies, the motor temperature is additionally increased as a result of the voltage boost (the motor overheats) !
- The voltage value at 0 Hz is determined from the product of rated motor current P0305, stator resistance P0350 and the appropriate parameters P1310 – P1312.

### 3.23.1.2 Slip compensation

Parameter range: P1335  
 Warnings: -  
 Faults: -  
 Function chart number: FP6100

In the V/f characteristic operating mode the motor frequency is always lower than the drive inverter output frequency by the slip frequency  $f_s$ . If the load (the load is increased from  $M_1$  to  $M_2$ ) is increased with a constant output frequency, then the slip  $s$  when motoring increases and the motor frequency decreases (from  $f_1$  to  $f_2$ ). This behavior, typical for an induction motor, can be compensated using slip compensation P1335. This therefore eliminates the speed reduction, caused by the load, by boosting (increasing) the drive inverter output frequency (refer to Fig. 3-98).

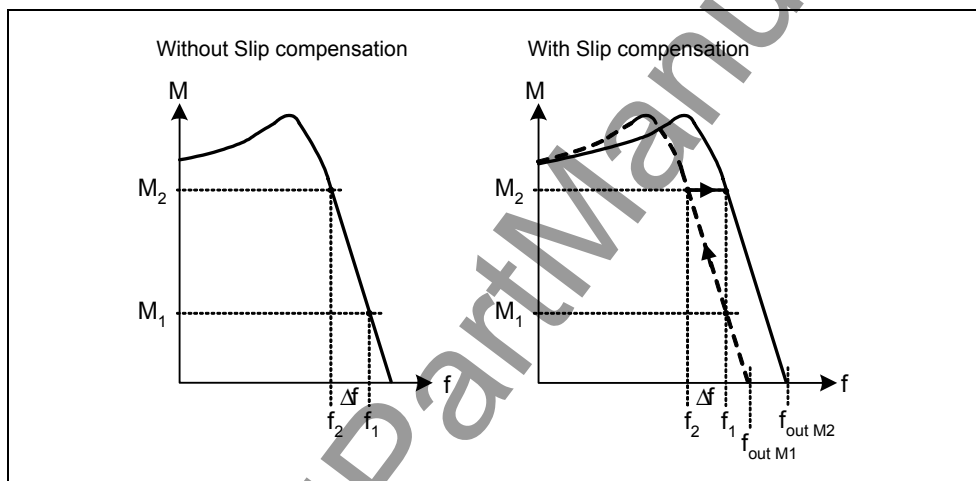


Fig. 3-98 Slip compensation

### 3.23.1.3 V/f resonance damping

Parameter range:	P1338
Warnings	-
Faults	-
Function chart number:	-

For variable-speed drives, resonance effects can occur in the upper frequency range (> 20 Hz). These resonance effects result in an increased noise level and also can damage / destroy the mechanical system. These resonance effects can occur for:

- Geared motors
- Reluctance motors
- Large motors  
(low stator resistance → poor electrical damping)

Contrary to the "skip frequency" function (refer to Section 3.12.1 and parameters P1091 to P1094), where the resonance frequency is passed through as quickly as possible, for the V/f resonance damping (parameter P1338), the resonance effects are damped from a control-related perspective. The advantage of this function is that by using this active damping, operation is possible in the resonance range.

The V/f resonance damping is activated and adjusted using parameter P1338. This parameter represents a gain factor that is a measure for the damping of the resonance frequency. The following oscillogram indicates the effect of the resonance damping function using as an example a reluctance motor with gearbox. The phase output currents are displayed for an output frequency of 45 Hz.

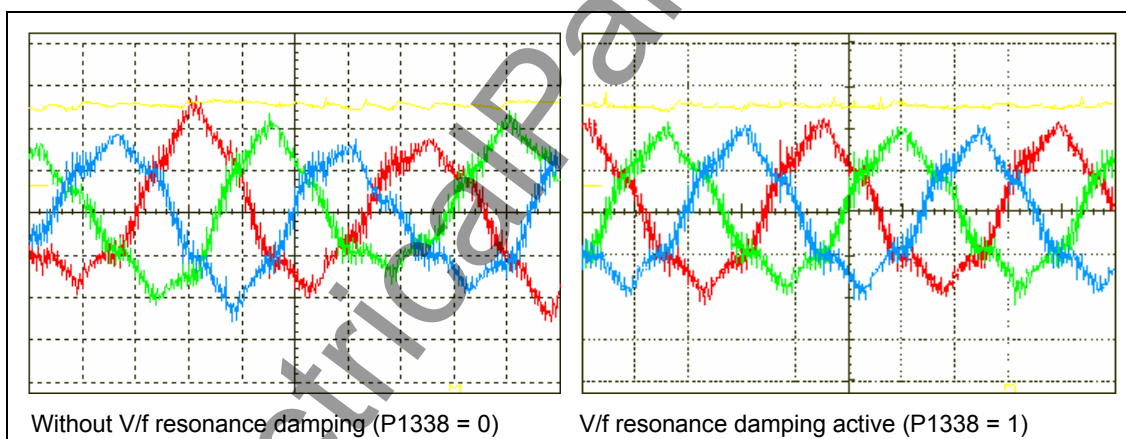
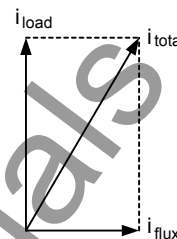


Fig. 3-99 Effect of V/f resonance damping

### 3.23.1.4 V/f open-loop control with flux current control (FCC)

Parameter range:	P1300, P1333
Warnings	-
Faults	-
Function chart number:	-

An improved current measurement function has been developed for our MICROMASTER drive inverters. This permits the output current to be precisely determined referred to the motor voltage. This measurement guarantees that the output current is sub-divided into a load component and a flux component. Using this sub-division, the motor flux can be controlled and can be appropriately adapted and optimized in-line with the prevailing conditions.



FCC operation is only activated after the FCC starting frequency P1333 has been exceeded. The FCC starting frequency P1333 is entered as a percentage to the rated motor frequency P0310. For a rated motor frequency of 50 Hz and a factory setting of P1333 = 10 %, this results in an FCC starting frequency of 5 Hz. The FCC starting frequency may not be selected too low as this has a negative impact on the control characteristics and can result in oscillation and system instability.

The "V/f with FCC" control type (P1300 = 1) has proven itself in many applications. It has the following advantages with respect to the standard V/f control:

- Higher motor efficiency
- Improved stabilizing characteristics
  - ◆ → higher dynamic response
  - ◆ → improved behavior to disturbances / control

---

#### NOTE

Contrary to closed-loop vector control with / without speed encoder (VC / SLVC), for the V/f open-loop control mode with FCC, it is not possible to specifically influence the motor torque. This is the reason that it isn't always possible to avoid the motor stalling – even when using "V/f with FCC".

An improvement in the stabilizing behavior and in the motor efficiency can be expected when using the closed-loop vector control with / without speed encoder when compared to V/f control with FCC.

---

### 3.23.1.5 Current limiting (I<sub>max</sub> controller)

Parameter range:	P1340 – P1346
	r0056 bit 13
Warnings	A0501
Faults	F0001
Function chart number:	FP6100

In the V/f characteristic mode, the drive inverter has a current limiting controller in order to avoid overload conditions (I<sub>max</sub> controller, refer to Fig. 3-100). This controller protects the drive inverter and the motor against continuous overload by automatically reducing the drive inverter output frequency by  $f_{I_{max}}$  (r1343) or the drive converter output voltage by  $V_{I_{max}}$  (r1344). By either reducing the frequency or voltage, the stressing on the drive inverter is reduced and it is protected against continuous overload and damage.

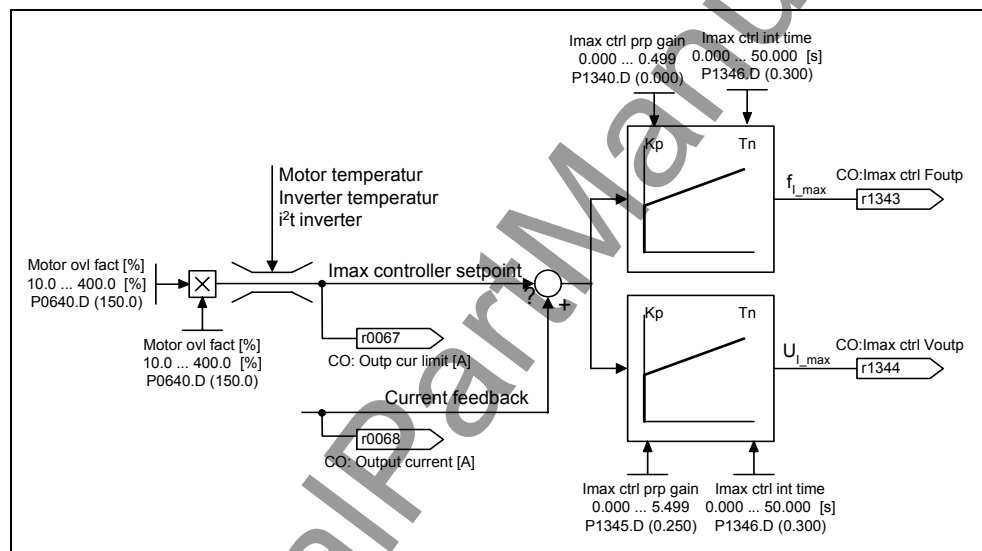


Fig. 3-100 I<sub>max</sub> controller

#### NOTE

The drive inverter load is only reduced when the frequency is reduced if the load decreases at lower speeds (e.g. square-law torque – speed characteristic of the driven load).

### 3.23.2 Vector control

Field-orientated Vector control (briefly: Vector control) significantly improves torque control when compared to V/f control. The Vector control principle is based on the fact that for a specific load situation or required torque, the required motor current is impressed with respect to the motor flux so that the appropriate torque is obtained. If the stator current is emulated in a circulating coordinate system, linked with the rotor flux  $\Phi$ , then it can be broken-down into flux-generating current component  $i_d$  in-line with the rotor flux and in a torque-generating current component  $i_q$ , vertical to the rotor flux. These components are corrected to track their setpoints in the current controller using their own dedicated PI controllers and are equal quantities in steady-state operation.

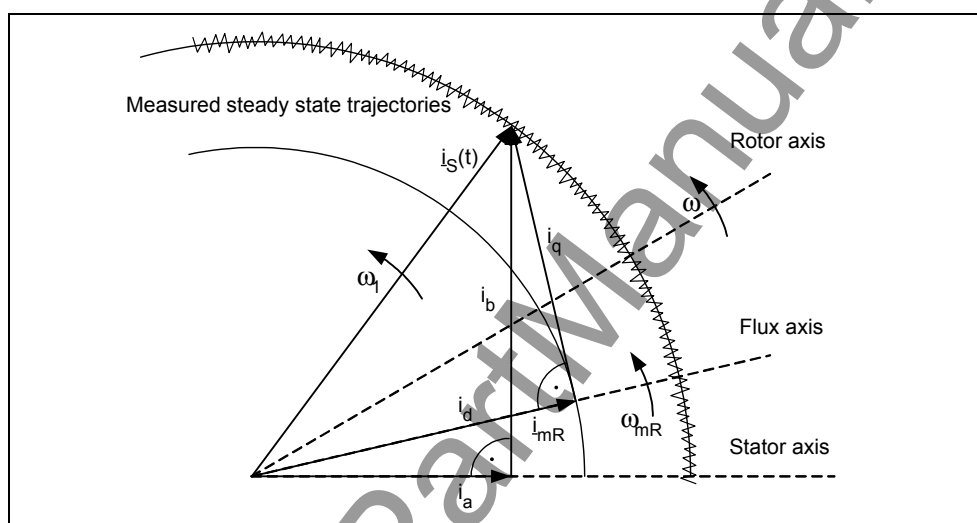


Fig. 3-101 Current Vector diagram in a steady-state condition

In the steady-state condition, the field-generating current component  $i_d$  is proportional to the flux  $\Phi$  and the torque is proportional to the product of  $i_d$  and  $i_q$ .

$$M \sim \Phi * i_q$$

$$\Phi \sim i_{d,stat}$$

$$M \sim i_d * i_q$$

When compared to V/f control, Vector control has the following advantages:

- Stable during load and setpoint changes
- Short rise times for setpoint changes (→ better control performance)
- Short rise times for load changes (→ better noise/disturbance characteristics)
- Accelerating and braking are possible with a max. adjustable torque
- The motor and driven machine are protected using the adjustable torque limit, both when motoring and regenerating (refer to Section 3.23.2.4)
- The drive and braking torque are controlled independently of the speed
- Full holding torque is possible at 0 speed

These advantages are, under certain circumstances, already achieved without using speed feedback.

The Vector control can be used both with and without speed encoder.

The following criteria provide a basis as to when a speed actual value encoder is required:

- High speed accuracy is required
- High requirements are placed on the dynamic response
  - ◆ Improved control performance
  - ◆ Improved immunity to disturbances
- The torque is to be controlled over a control range greater than 1:10
- A defined and/or a changing torque has to be maintained for speeds below approx. 10 % of the rated motor frequency P0310

When it comes to entering a setpoint, the Vector control (refer to Table 3-40) is sub-divided into

- Closed-loop speed control, and
- Closed-loop torque/current control (briefly: Closed-loop torque control).

Table 3-40 Vector control versions

Vector control (closed-loop)	Without encoder	With encoder
Closed-loop speed control	P1300 = 20, P1501 = 0	P1300 = 21, P1501 = 0
Closed-loop torque control	P1300 = 20, P1501 = 1 P1300 = 22	P1300 = 21, P1501 = 1 P1300 = 23

When closed-loop speed control is used, the closed-loop torque control is secondary. This type of cascaded closed-loop control has proven itself in practice regarding commissioning and increased transparency.

### 3.23.2.1 Vector control without speed encoder (SLVC)

Parameter range: P1400 – P1780  
 P1610, P1611  
 P1755, P1756, P1758  
 P1750

Warnings -  
 Faults -  
 Function chart number: FP7000

When Vector control is used without speed encoder (refer to Table 3-40) then the position of the flux and the actual speed must be determined using the motor model. In this case, the model is supported by the accessible currents and voltages. At low frequencies ( $\approx 0$  Hz), the model is not able to determine the speed. This is the reason and also due to uncertainty in the model parameters and measuring inaccuracy, that a changeover is made from closed-loop to open-loop controlled operation in this range.

The changeover between closed-loop controlled / open-loop controlled operation is controlled using the time and frequency conditions (P1755, P1756, P1758) (refer to Fig. 3-102). The system does not wait for the time condition if the setpoint frequency at the ramp-function generator input and the actual frequency simultaneously lie below P1756.

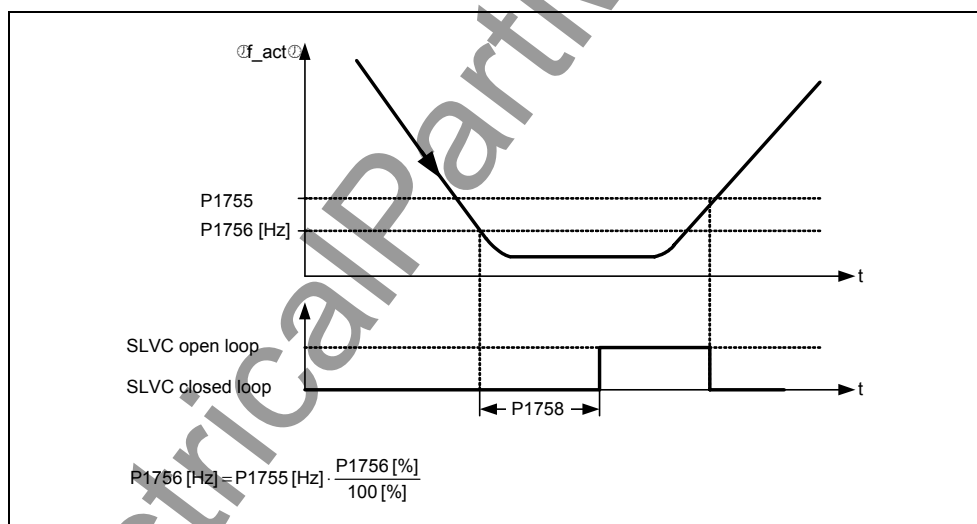


Fig. 3-102 Changeover condition for SLVC

In the open-loop controlled mode, the speed actual value is the same as the setpoint. For suspended loads or when accelerating, parameter P1610 (constant torque boost) and P1611 (torque boost when accelerating) must be modified in order to allow the drive to provide the steady-state and/or dynamic load torque. If P1610 is set to 0 %, then only the magnetizing current r0331 is impressed for a value of 100 % of the rated motor current P0305. In order that the drive does not stall when accelerating, P1611 can be increased or the acceleration pre-control can be used for the speed controller (refer to Section 3.23.2.3). This is also practical in order that the motor is not thermally overloaded at low speeds.

For Vector control without speed actual value encoder MICROMASTER 440 has, in the low frequency range, the following outstanding features with respect to other AC drive inverters:

- Closed-loop controlled operation down to  $\approx 1$  Hz
- Can start in the closed-loop controlled mode (immediately after the drive has been energized)
- The low frequency range (0 Hz) is passed-through in closed-loop controlled operation

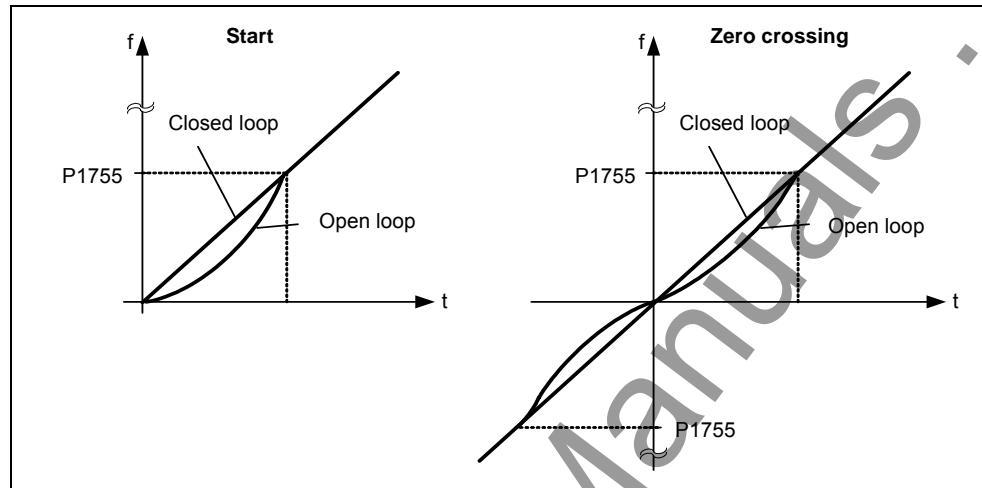


Fig. 3-103 Starting and passing-through 0 Hz in closed-loop controlled operation

The following advantages are obtained as a result of closed-loop controlled operation down to approx. 1 Hz (this can be selected using parameter P1755) as well as also the possibility to immediately start closed-loop controlled at 0 Hz or to reverse closed-loop controlled (this can be set using parameter P1750):

- No changeover operation is required within the closed-loop control (smooth behavior – no frequency dips)
- Continuous closed-loop speed-torque control is possible down to approx. 1 Hz.

#### NOTE

For closed-loop controlled reversing or closed-loop controlled starting from 0 Hz it must be taken into account that when staying too long ( $> 2$  s or  $> P1758$ ) in the range around 0 Hz, that the closed-loop control automatically changes-over from closed-loop into the open-loop controlled mode.

### 3.23.2.2 Vector control with speed encoder (VC)

Parameter range: P1400 – P1740  
P0400 – P0494

Warnings -

Faults -

Function chart number: FP7000

For Vector control with speed encoder (refer to Table 3-40), a pulse encoder evaluation (option module) as well as a pulse encoder, e.g. encoder with 1024 pulses/revolution are required. In addition to the correct wiring, the pulse encoder module must be activated, corresponding to the encoder type, using the parameter range P0400 – P0494 or using the DIP switch on the module (refer to Fig. 3-104).

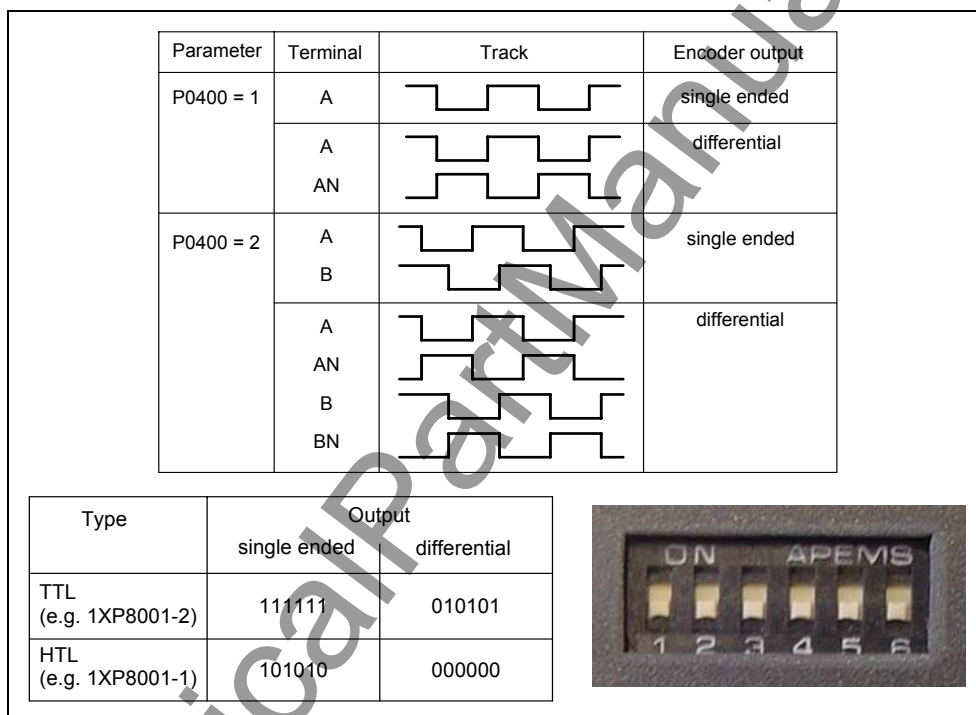


Fig. 3-104 P0400 and DIP switch on the pulse encoder module

#### Advantages of Vector control with encoder:

- The speed can be closed-loop controlled down to 0 Hz (i.e. at standstill)
- Stable control behavior over the complete speed range
- Constant torque in the rated speed range
- When compared to closed-loop speed control without encoder, the dynamic response for drives with encoder is significantly higher as the speed is directly measured and is incorporated in generating the model of current components  $i_d$ ,  $i_q$ .

### 3.23.2.3 Speed controller

Parameter range: P1300, P1400 – P1780  
 SLVC: P1470, P1472, P1452  
 VC: P1460, P1462, P1442

Warnings -  
 Faults -  
 Function chart number: FP7500, FP7510

Both of the control techniques (SLVC, VC) have the same speed controller structure which includes the following components as kernel:

- PI controller
- Speed controller pre-control
- Droop

The sum of the output quantities forms the speed setpoint, which is reduced to the permissible level using the torque setpoint limiting function (refer to Section 3.23.2.4).

#### Speed controller (SLVC: P1470, P1472, P1452 VC: P1460, P1462, P1442)

The speed controller (refer to Fig. 3-105) receives its setpoint r0062 from the setpoint channel (refer to Section 3.12), the actual value r0063 either directly from the speed actual value encoder or, for VC, also directly through the motor model for SLVC. The system error is amplified by the PI controller and, together with the pre-control, forms the torque setpoint.

For increasing load torques, when the droop function is active, the speed setpoint is proportionally reduced so that the load on an individual drive within a group (where two or several motors are mechanically coupled) is reduced when excessively high torques occur.

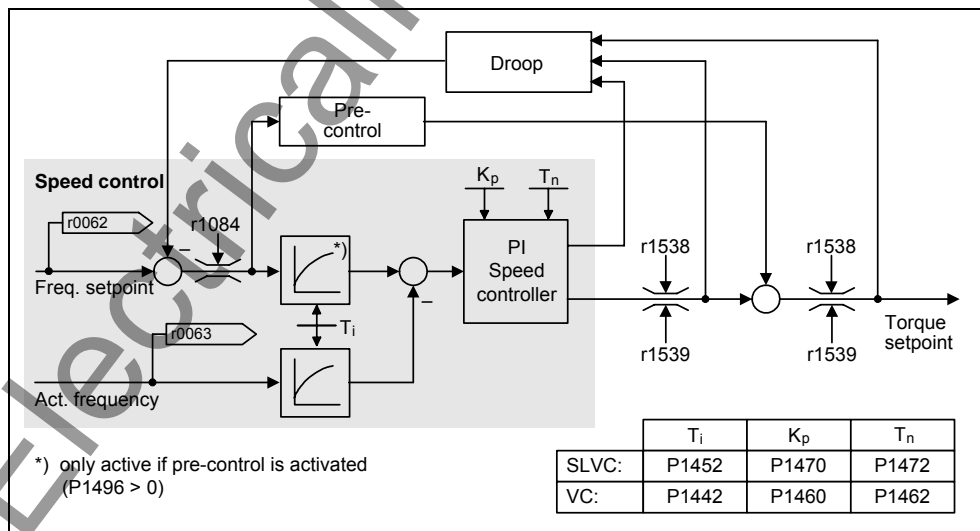


Fig. 3-105 Speed controller

If the moment of inertia was entered, the speed controller ( $K_p, T_n$ ) can be calculated using the automatic parameterization (P0340 = 4) (refer to Section 3.5.4). The controller parameters are defined according to the symmetrical optimum as follows:

$$T_n = 4 * T_\sigma$$

$$K_p = \frac{1}{2} * r0345 / T_\sigma = 2 * r0345 / T_n$$

$T_\sigma$  = sum of the low delay times

If oscillations occur with these particular settings, then the speed controller gain  $K_p$  should be manually reduced. It is also possible to increase the speed actual value smoothing (this is the usual procedure for gearbox play or high-frequency torsional oscillations) and then re-call the controller calculation as the value is incorporated in the computation of  $K_p$  and  $T_n$ .

The following interrelationships apply for the optimization routine:

- If  $K_p$  is increased then the controller becomes faster and the overshoot is reduced. However, the signal ripple and oscillations in the speed controller loop are increased.
- If  $T_n$  is reduced, then the controller also becomes faster. However, the overshoot increases.

When manually adjusting the speed control, the simplest procedure is to initially define the possible dynamic response using  $K_p$  (and the speed actual value smoothing) in order to then reduce the integral action time as far as possible. In this case it is important to ensure that the closed-loop control must also remain stable in the field-weakening range.

When oscillations occur in the closed-loop speed control, it is generally sufficient to increase the smoothing time in P1452 for SLVC or P1442 for VC (or to reduce the controller gain) in order to dampen oscillations.

The integral output of the speed controller can be monitored using r1482 and the unlimited controller output can be monitored using r1508 (torque setpoint).

---

#### NOTE

When compared to closed-loop control with encoder (refer to Section 3.23.2.2), the dynamic response for sensorless drives is significantly reduced. This is because the speed can only be derived from the drive inverter output quantities for current and voltage which have the appropriate noise level.

---

### Speed controller pre-control (P1496, P0341, P0342)

The control behavior of the speed control loop can be improved if the speed controller of the drive inverter also generates values for the current setpoints (corresponds to the torque setpoint) from the speed setpoint. This torque setpoint  $m_v$ , which is calculated as follows  $m_v = P1496 \cdot \Theta \cdot \frac{dn}{dt} = P1496 \cdot P0341 \cdot P0342 \cdot \frac{dn}{dt}$

is entered into the current controller through an adaptation element directly as additive control quantity (this is enabled using P1496).

The motor moment of inertia P0341 is directly calculated during the quick commissioning (refer to Section 3.5.8) or the complete parameterization (P0340 = 1, refer to Section 3.5.4). The factor P0342 between the total moment of inertia and motor moment of inertia must be manually determined.

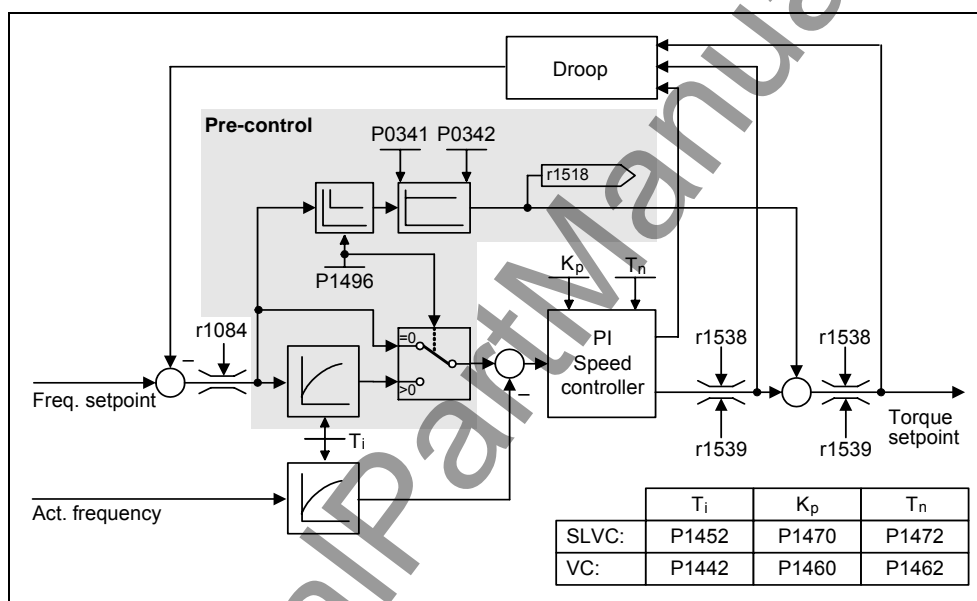


Fig. 3-106 Speed controller with pre-control

When correctly adapted, then the speed controller only has to correct noise quantities/disturbances in its control loop and this is achieved with a relatively low manipulated quantity change. On the other hand, speed setpoint changes bypass the speed controller and are therefore executed faster.

The effect of the pre-control quantity can be adapted, depending on the particular application, using the pre-control factor P1496. Using P1496 = 100 %, the pre-control is calculated according to the motor and load moment of inertia (P0341, P0342). In order that the speed controller does not work against the torque setpoint which is entered, a balancing filter is automatically used. The time constant of the balancing filter corresponds to the equivalent delay time of the speed control loop. The speed controller pre-control is correctly set (P1496 = 100 %, calibration via P0342), if the I component of the speed controller (r1482) does not change during a ramp-up or ramp-down in the range  $n > 20\% \cdot P0310$ . This means, using the pre-control, it is possible to approach a new speed setpoint without overshoot (prerequisite: The torque limiting does not intervene and the moment of inertia remains constant).

If the speed controller is pre-controlled, then the speed setpoint (r0062) is delayed with the same smoothing (P1442 or P1452) as the actual value (r1445). This ensures that when accelerating, there is no setpoint – actual value difference (r0064) at the controller input which would have been exclusively caused by the signal propagation time.

When the speed pre-control is activated, it must be ensured that the speed setpoint is continuously entered and without any significant noise level (avoid torque surges). An appropriate signal can be generated by smoothing the analog signal ♦ P0753 (refer to Section 3.6.3) or by activating the rounding-off function of the ramp-function generator P1130 – P1133 (refer to Section 3.12.2).

---

#### NOTE

- The ramp-up and ramp-down times (P1120; P1121) of the ramp-function generator (refer to Section 3.12.2) in the setpoint channel should only be set so fast that when accelerating and braking, the motor speed can follow the setpoint. This then guarantees the optimum functioning of the speed controller pre-control.
- The starting time r0345 is a measure for the overall moment of inertia of the machine and describes that time in which the unloaded drive can accelerate from standstill to the rated motor speed P0311 with the rated motor torque r0333.

$$r0345 = T_{\text{starting}} = \Theta \cdot \frac{2 \cdot \pi \cdot n_{\text{Mot, rated}}}{60 \cdot M_{\text{Mot, rated}}} = P0341 \cdot P0342 \cdot \frac{2 \cdot \pi \cdot P0311}{60 \cdot r0333}$$

If these secondary conditions match the particular application, then the starting time can be used as the shortest value for the ramp-up and ramp-down times.

---

### Droop (P1488 – P1492)

The droop (enabled using P1488) means that with increasing load torque, the speed setpoint is proportionally reduced.

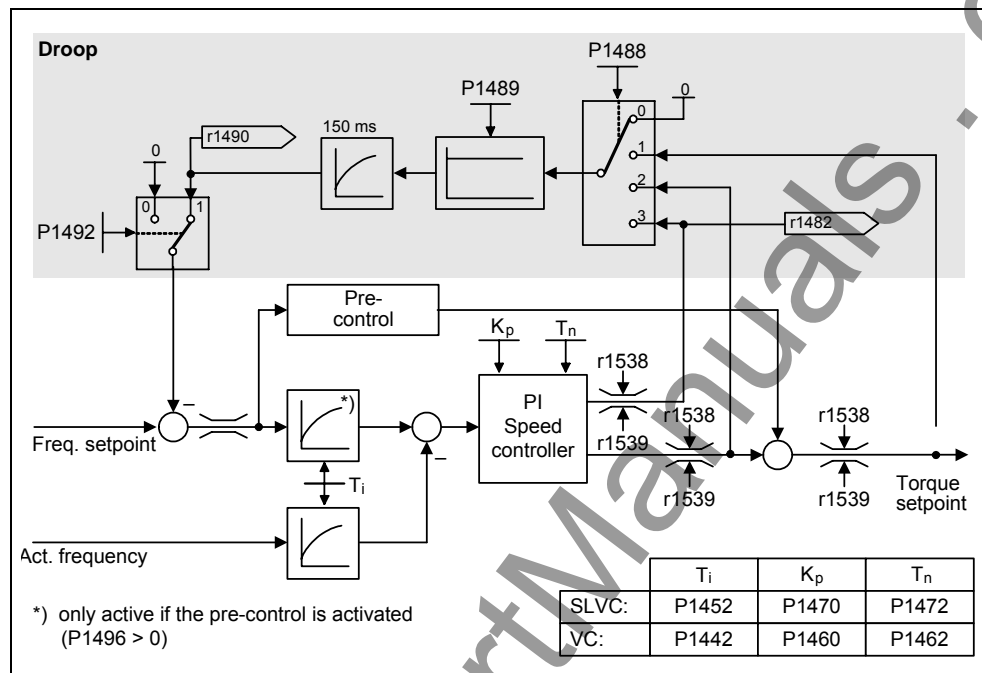


Fig. 3-107 Speed controller with droop

Droop is the simplest method to implement load sharing control. However, this load sharing control can only be used if the drives only motor and are operated more or less under steady-state conditions (i.e. at constant speed). For drives, which are frequently accelerated and braked with high speed changes, this technique is only conditionally suitable.

The most simple load sharing control is, e.g., used for applications where two or several motors are mechanically coupled or operate on a common shaft and which have to fulfill the requirements above. In this case, the droop controls torsional stressing associated with the mechanical coupling by changing the speeds of the individual motors (excessive torques are reduced for an individual drive).

#### Prerequisite

- All of the drives must be operated with closed-loop Vector speed control (with or without speed actual value encoder)
- The ramp-up and ramp-down times of the ramp-function generator must be identical for all of the drives.

### 3.23.2.4 Closed-loop torque control

Parameter range: P1300, P1500 – P1511  
P1400 – P1780

Warnings -

Faults -

Function chart number: FP7200, FP7210, FP7700, FP7710

For sensorless closed-loop speed control SLVC (P1300 = 20) or for closed-loop speed control with sensor VC (P1300 = 21), it is possible to changeover to closed-loop torque control (slave drive) using BICO parameter P1501. It is not possible to changeover between closed-loop speed and torque control if the closed-loop torque control is directly selected using P1300 = 22 or 23. The torque setpoint and supplementary torque setpoint can be selected using parameter P1500 and also using BICO parameter P1503 (CI: Torque setpoint) or P1511 (CI: Supplementary torque setpoint). The supplementary torque acts both for the closed-loop torque control as well as for the closed-loop speed control (refer to Fig. 3-108). As a result of this feature, a pre-control torque for the speed control can be implemented using the supplementary torque setpoint.

**NOTE**

For safety reasons, it is presently not possible to assign fixed torque setpoints.

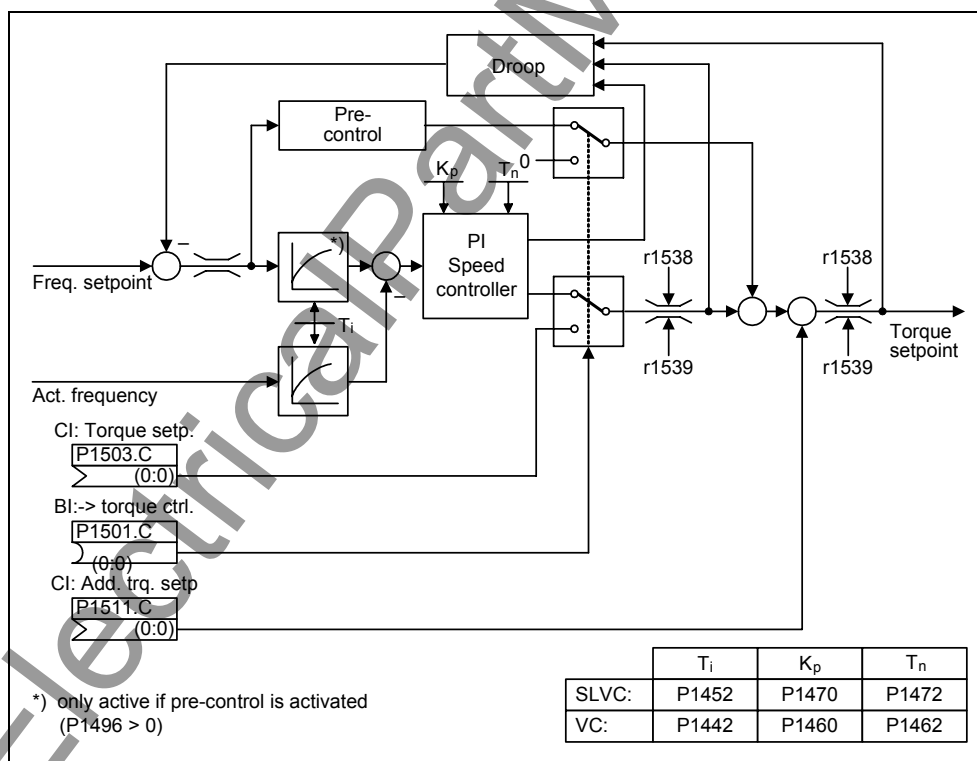


Fig. 3-108 Closed-loop speed/torque control

The sum of both torque setpoints is limited in the same way as the torque setpoint of the speed control (refer to Section 3.23.2.5). Above the maximum speed (plus 3 %), a speed limiting controller reduces the torque limits in order to prevent the drive accelerating any further.

A "real" closed-loop torque control (with automatically set speed) is only possible in the closed-loop controlled range but not in the open-loop controlled range. In the open-loop controlled range, the torque setpoint changes the setpoint speed through a ramp-up integrator (integration time  $\sim P1499 * P0341 * P0342$ ). This is the reason that sensorless closed-loop torque control in the area around standstill (0 speed) is only suitable for applications which require an accelerating torque there and not a load torque (e.g. traversing drives). For closed-loop torque control with sensors, this restriction does not apply.

If the closed-loop torque control is active, and a fast stop command (OFF3) is output, then the system automatically changes-over to closed-loop speed control and the drive is braked. If a normal stop command (OFF1) is output, there is no changeover. Instead, the system waits until a higher-level control has brought the drive to a standstill, in order to inhibit the pulses there. This is necessary in order to allow the master and slave drives to be shut down together. For P1300 = 22 or 23, for OFF1, the drive is directly powered-down (as for OFF2).

### 3.23.2.5 Limiting the torque setpoint

Parameter range: P1520 – P1531  
P0640, r0067  
r1407 bit 08, r1407 bit 09

Warnings -

Faults -

Function chart number: FP7700, FP7710

All of the following limits act on the torque setpoint which is either entered at the speed controller output for closed-loop speed control or as torque input for closed-loop torque control. The minimum is used from the various limits. This minimum is cyclically computed in the drive inverter and displayed in parameters r1538, r1539.

- r1538 Upper torque limit
- r1539 Lower torque limit

This means that these cyclic values limit the torque setpoint at the speed controller output / torque input and indicate the instantaneously maximum possible torque. If the torque setpoint is limited in the drive inverter, then this is displayed using the following diagnostic parameters

- r1407 bit 08 Upper torque limit active
- r1407 bit 09 Lower torque limit active

## Torque limiting

The value specifies the maximum permissible torque whereby different limits are parameterizable for motoring and regenerative operation.

- P1520 CO: Upper torque limit value
- P1521 CO: Lower torque limit value
- P1522 CI: Upper torque limit value
- P1523 CI: Lower torque limit value
- P1525 Scaling, lower torque limit value

The currently active torque limit values are displayed in the following parameters:

- r1526 CO: Upper torque limit value
- r1527 CO: Lower torque limit value

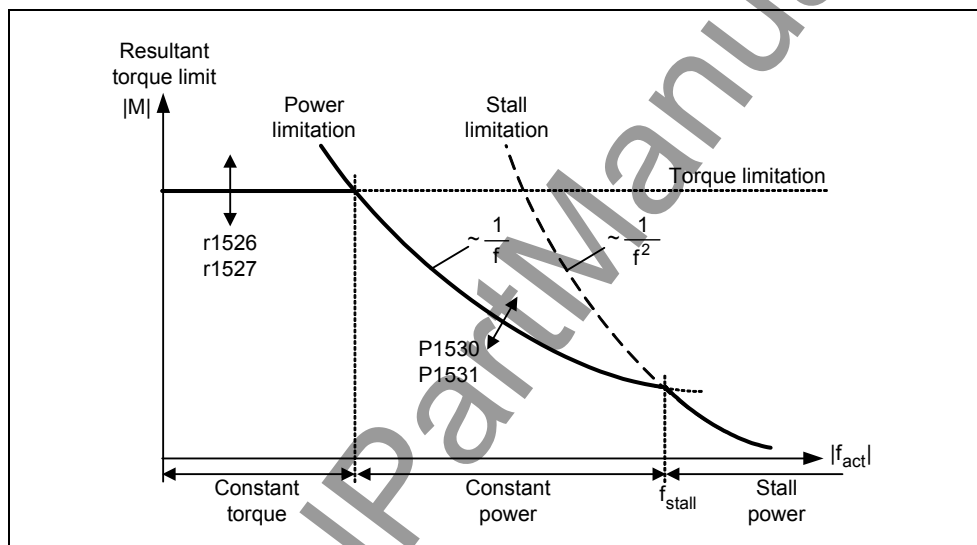


Fig. 3-109 Torque limits

## Power limits

This value specifies the maximum permissible power, whereby different limits can be parameterized for motoring and regenerative operation.

- P1530 Motor power limit
- P1531 Regenerative power limit

## Stall limiting (locked rotor limiting)

The stall limiting is internally calculated in the drive from the motor data.

### Current limiting

The current limiting additionally limits the maximum torque which the motor can provide. If the torque limit is increased, more torque is only available if a higher current can flow. It may be necessary to also adapt the current limit. The current limiting is influenced by:

- P0640 motor overload factor
- Thermal motor protection (refer to Section 3.21)
- Thermal drive inverter protection (refer to Section 3.22)

After limiting, the instantaneous maximum possible drive inverter current is displayed in parameter r0067 (limited output current).

## 4 Troubleshooting

**This Chapter contains:**

- An overview of the operating statuses of the inverter with the SDP
- Notes on troubleshooting with the BOP
- Information and instructions on alarms and fault messages

4.1	Troubleshooting with the SDP .....	258
4.2	Troubleshooting with the BOP .....	259
4.3	Fault messages.....	260
4.4	Alarm messages .....	260

www.ElectricalPartManuals.com

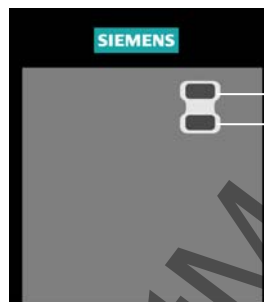


**WARNING**

- Repairs on equipment may only be carried out by **Siemens Service**, by repair centers **authorized by Siemens** or by qualified personnel who are thoroughly acquainted with all the warnings and operating procedures contained in this manual.
- Any defective parts or components must be replaced using parts contained in the relevant spare parts list.
- Disconnect the power supply before opening the equipment for access

**4.1 Troubleshooting with the SDP**

Table 4-1 explains the meaning of the various states of the LEDs on the SDP.



- LEDs for indicating the drive state
  - Off
  - ☀ On
  - ⦿ approx. 0,3 s, flashing
  - ⦿ approx. 1 s, twinkling

Table 4-1 Inverter conditions indicated by the LEDs on the SDP

● ●	Mains not present	☀	Fault inverter temperature
☀ ☀	Ready to run	⦿ ⦿	Warning current limit - both LEDs twinkling <b>same time</b>
● ☀	Inverter fault - other than the ones listed below	⦿ ⦿	Other warnings - both LEDs twinkling <b>alternatively</b>
☀ ●	Inverter running	⦿ ⦿	Undervoltage trip / undervoltage warning
● ⦿	Fault overcurrent	⦿ ⦿	Drive is not in ready state
⦿ ●	Fault overvoltage	⦿ ⦿	ROM failure - Both LEDs flashing <b>same time</b>
⦿ ☀	Fault motor overtemperature	⦿ ⦿	RAM failure - Both LEDs flashing <b>alternatively</b>

## 4.2 Troubleshooting with the BOP

Warnings and faults are displayed on the BOP with Axxx and Fxxx respectively. The individual messages are shown in the Parameter list.

If the motor fails to start when the ON command has been given:

- Check that P0010 = 0.
- Check that a valid ON signal is present.
- Check that P0700 = 2 (for digital input control) or P0700 = 1 (for BOP control).
- Check that the setpoint is present (0 to 10V on Terminal 3) or the setpoint has been entered into the correct parameter, depending upon the setpoint source (P1000). See the Parameter List for further details.

If the motor fails to run after changing the parameters, set P0010 = 30 then P0970 = 1 and press **P** to reset the inverter to the factory default parameter values.

Now use a switch between terminals **5** and **9** (Figure 3-14). The drive should now run to the defined setpoint by analogue input.

---

### NOTICE

Motor data must relate to the inverter data power range and voltage.

---


### 4.3 Fault messages

In the event of a failure, the inverter switches off and a fault code appears on the display.

---

**NOTE**

To reset the fault code, one of three methods listed below can be used:

1. Cycle the power to the drive.
  2. Press the  button on the BOP or AOP.
  3. Via Digital Input 3 (default setting)
- 

Fault messages are stored in parameter r0947 under their code number (e.g. F0003 = 3). The associated error value is found in parameter r0949. The value 0 is entered if a fault has no error value. It is furthermore possible to read out the point in time that a fault occurred (r0948) and the number of fault messages (P0952) stored in Parameter r0947.

A detailed description of the fault messages is provided in the parameter list.

### 4.4 Alarm Messages

Alarm messages are stored in parameter r2110 under their code number (e.g. A0503 = 503) and can be read out from there.

A detailed description of the alarm messages is provided in the parameter list.

## 5 MICROMASTER 440 specifications

### This Chapter contains:

- Table 5.1 contains the general technical specifications for the MICROMASTER 440 inverter
- Table 5-2 contains dimensions, the required cooling air flow and tightening torque for power connections
- Table 5-3 contains current values, depending on the pulse frequency
- Table 5-4 contains data for the braking resistors
- Table 5-5 includes various tables of specific technical data for individual MICROMASTER 440 inverters

Table 5-1 MICROMASTER 440 Performance Ratings

Feature		Specification
Mains Operating Voltage & Power Ranges		1 AC 200 to 240 V $\pm$ 10 % CT: 0,12 kW – 3,0 kW (0,16 hp – 4,0 hp)
		3 AC 200 to 240 V $\pm$ 10 % CT: 0,12 kW – 45,0 kW (0,16 hp – 60,0 hp) VT: 5,50 kW – 45,0 kW (7,50 hp – 60,0 hp)
		3 AC 380 to 480 V $\pm$ 10 % CT: 0,37 kW – 200 kW (0,50 hp – 268 hp) VT: 7,50 kW – 250 kW (10,0 hp – 335 hp)
		3 AC 500 to 600 V $\pm$ 10 % CT: 0,75 kW – 75,0 kW (1,00 hp – 100 hp) VT: 1,50 kW – 90,0 kW (2,00 hp – 120 hp)
Input Frequency		47 to 63 Hz
Output frequency		0 Hz to 650 Hz
Power Factor		0.95
Inverter Efficiency		Frame Sizes A to F: 96 % to 97 % Frame Sizes FX and GX: 97 % to 98 %
Overload Capability	Constant Torque (CT)	Frame Sizes A to F: 1.5 x Nominal output current (i.e. 150 % overload) for 60 s every 300 s and 2 x Nominal output current (i.e. 200 % overload) for 3 s every 300 s Frame Sizes FX and GX: 1.36 x Nominal output current (i.e. 136 % overload) for 57 s every 300 s and 1.6 x Nominal output current (i.e. 160 % overload) for 3 s every 300 s
	Variable Torque (VT)	Frame Sizes A to F: 1.1 x Nominal output current (i.e. 110 % overload) for 60 s every 300 s and 1.4 x Nominal output current (i.e. 140 % overload) for 3 s every 300 s Frame Sizes FX and GX: 1.1 x Nominal output current (i.e. 110% overload) for 59 s every 300 s and 1.5 x Nominal output current (i.e. 150% overload) for 1 s every 300s
Inrush Current		Less than rated input current
Power-ON-OFF cycle time		Frame Sizes A to E: every 30 s Frame Size F: every 150 s Frame Sizes FX and GX: every 300 s
Control Method		V/f control, output frequency between 0 Hz and 650 Hz: Linear V/f control, Linear V/f control with FCC, Parabolic V/f control, Multi-point V/f control, V/f control for textile applications, V/f control with FCC for textile applications, V/f control with independent voltage setpoint, Vector control, output frequency between 0 Hz and 200 Hz: Sensorless Vector Control, Sensorless Vector Torque Control, Speed control with Encoder Feedback, Torque control with Encoder Feedback
Pulse Frequency		Frame Sizes A to C: 1/3AC 200 V to 5,5 kW (Standard 16 kHz) Frame Sizes A to F: other powers and voltages 2 kHz to 16 kHz (2 kHz steps) (Standard 4 kHz) power reduction see Table 5-3 Frame Sizes FX and GX: 2 kHz to 4 kHz (2 kHz steps) (Standard 2 kHz (VT), 4 kHz (CT)) power reduction see Table 5-3
Fixed Frequencies		15, programmable
Skip Frequencies		4, programmable
Setpoint Resolution		0.01 Hz Digital, 0.01 Hz Serial, 10 bit Analogue (motor potentiometer 0.1 Hz [0.1% (in PID mode)])
Digital Inputs		6, programmable (isolated), switchable active high / active low (PNP/NPN)
Analog Inputs		2, programmable, both are parameterizable as 7th and 8th digital inputs 0 V to 10 V, 0 mA to 20 mA and –10 V to +10 V (ADC1) 0 V to 10 V and 0 mA to 20 mA (ADC2)
Relay Outputs		3, programmable 30 V DC / 5 A (resistive), 250 V AC 2 A (inductive)
Analogue Output		2, programmable (0 to 20 mA)

Feature	Specification
Serial Interface	RS485, optional RS232
Electromagnetic Compatibility	<p>Frame Sizes A to C: optional class A or B filters available according to EN55011</p> <p>Frame Sizes A to F: inverter with integrated class A filter available</p> <p>Frame Sizes FX and GX: With EMI filter (available as an option) the limiting values of the EN 55011, Class A are fulfilled for conducted emission. (line commutating choke required)</p>
Braking	<p>DC braking, compound braking</p> <p>Dynamic braking      Frame Sizes A to F      with integrated chopper  Frame Sizes FX and GX      with external chopper</p>
Protection Level	IP20
Temperature range	<p>Frame Sizes A to F:      -10 °C to +50 °C (14 °F to 122 °F) (CT)  -10 °C to +40 °C (14 °F to 104 °F) (VT)</p> <p>Frame Sizes FX and GX: 0 °C to +40 °C (32 °F to 104 °F),  up to 55 °C (131 °F) Power reduction see Figure 2.2</p>
Storage Temperature	-40 °C to +70 °C (-40 °F to 158 °F)
Humidity	< 95 % RH – non-condensing
Operational Altitudes	<p>Frame Sizes A to F:      Up to 1000 m above sea level without derating</p> <p>Frame Sizes FX and GX: Up to 2000 m above sea level without derating</p>
Protection Features	Undervoltage, Overvoltage, Overload, Ground Faults, Short circuit, Stall Prevention, Motor Blocking Protection, Motor Overtemperature, Inverter Overtemperature, Parameter Interlock
Standards	<p>Frame Sizes A to F:      UL, cUL, CE, C-tick</p> <p>Frame Sizes FX and GX: UL, cUL, CE</p>
CE Marked	Conformity with EC Low Voltage Directive 73/23/EEC and filtered versions also Electromagnetic Compatibility Directive 89/336/EEC

Table 5-2 Dimensions, required cooling air flow and tightening torques for power terminals

Frame Size	Dimensions			Required cooling air flow		Tightening torque for power connections	
A	WxHxD	mm	73 × 173 × 149	l/s	4.8	Nm	1.1
		inch	2.87 × 6.81 × 5.87	CFM	10.2		
B	WxHxD	mm	149 × 202 × 172	l/s	24	Nm	1.5
		inch	5.87 × 7.95 × 6.77	CFM	51		
C	WxHxD	mm	185 × 245 × 195	l/s	54.9	Nm	2.25
		inch	7.28 × 9.65 × 7.68	CFM	116.3		
D	WxHxD	mm	275 × 520 × 245	l/s	2 × 54.9	Nm	10 (max.)
		inch	10.82 × 20.47 × 9.65	CFM	2 × 116.3		
E	WxHxD	mm	275 × 650 × 245	l/s	2 × 54.9	Nm	10 (max.)
		inch	10.82 × 25.59 × 9.65	CFM	2 × 116.3		
F	WxHxD	mm	350 × 850 Height with filter 1150	l/s	150	Nm	50
		inch	13.78 × 33.46 × 12.60 Height with filter 45.28	CFM	317.79		
FX	WxHxD	mm	326 × 1400 × 356	l/s	225	Nm	25
		inch	12.80 × 55.12 × 12.83	CFM	478.13		
GX	WxHxD	mm	326 × 1533 × 545	l/s	440	Nm	25
		inch	12.80 × 60.35 × 21.46	CFM	935		

Table 5-3 Current reduction depending on pulse frequency

Mains voltage	Power (CT) [kW]	Output current in A with a switching frequency of;						
		4 kHz	6 kHz	8 kHz	10 kHz	12 kHz	14 kHz	16 kHz
1/3 AC 200 V	0.12 to 5.5	Factory setting 16 kHz – no derating necessary						
	7.5	28.0	26.6	25.2	22.4	19.6	16.8	14.0
	11	42.0	37.8	33.6	29.4	25.2	21.0	16.8
	15	54.0	48.6	43.2	37.8	32.4	27.0	21.6
	18.5	68.0	64.6	61.2	54.4	47.6	40.8	34.0
	22	80.0	72.0	64.0	56.0	48.0	40.0	32.0
	30	104.0	91.0	78.0	70.2	62.4	57.2	52.0
	37	130.0	113.8	97.5	87.8	78.0	71.5	65.0
	45	154.0	134.8	115.5	104.0	92.4	84.7	77.0
3 AC 400 V	0.37	1.3	1.3	1.3	1.3	1.3	1.2	1.0
	0.55	1.7	1.7	1.7	1.6	1.5	1.4	1.2
	0.75	2.2	2.2	2.2	2.0	1.8	1.5	1.3
	1.1	3.1	2.9	2.8	2.5	2.2	1.9	1.6
	1.5	4.1	3.7	3.3	2.9	2.5	2.1	1.6
	2.2	5.9	5.6	5.3	4.7	4.1	3.5	3.0
	3.0	7.7	6.9	6.2	5.4	4.6	3.9	3.1
	4.0	10.2	9.2	8.2	7.1	6.1	5.1	4.1
	5.5	13.2	11.9	10.6	9.2	7.9	6.6	5.3
	7.5	19.0	18.1	17.1	15.2	13.3	11.4	9.5
	11.0	26.0	23.4	20.8	18.2	15.6	13.0	10.4
	15.0	32.0	30.4	28.8	25.6	22.4	19.2	16.0
	18.5	38.0	34.2	30.4	26.6	22.8	19.0	15.2
	22	45.0	40.5	36.0	31.5	27.0	22.5	18.0
	30	62.0	58.9	55.8	49.6	43.4	37.2	31.0
	37	75.0	67.5	60.0	52.5	45.0	37.5	30.0
	45	90.0	76.5	63.0	51.8	40.5	33.8	27.0
	55	110.0	93.5	77.0	63.3	49.5	41.3	33.0
75	145.0	112.4	79.8	68.9	58.0	50.8	43.5	
90	178.0	–	–	–	–	–	–	
110	205.0	–	–	–	–	–	–	
132	250.0	–	–	–	–	–	–	
160	302.0	–	–	–	–	–	–	
200	370.0	–	–	–	–	–	–	
3 AC 500 V	0.75	1.4	1.2	1.0	0.8	0.7	0.6	0.6
	1.5	2.7	2.2	1.6	1.4	1.1	0.9	0.8
	2.2	3.9	2.9	2.0	1.6	1.2	1.0	0.8
	4.0	6.1	4.6	3.1	2.4	1.8	1.5	1.2
	5.5	9.0	6.8	4.5	3.6	2.7	2.3	1.8
	7.5	11.0	8.8	6.6	5.5	4.4	3.9	3.3
	11.0	17.0	12.8	8.5	6.8	5.1	4.3	3.4
	15.0	22.0	17.6	13.2	11.0	8.8	7.7	6.6
	18.5	27.0	20.3	13.5	10.8	8.1	6.8	5.4
	22	32.0	24.0	16.0	12.8	9.6	8.0	6.4
	30	41.0	32.8	24.6	20.5	16.4	14.4	12.3
	37	52.0	39.0	26.0	20.8	15.6	13.0	10.4
	45	62.0	52.7	43.4	40.3	37.2	32.6	27.9
55	77.0	67.4	57.8	52.0	46.2	42.4	38.5	
75	99.0	84.2	69.3	64.4	59.4	52.0	44.6	

Table 5-4 Data for braking resistors

Rated voltage	V <sub>DC_max</sub>	I <sub>DC_max</sub> for Frame Size					
		A	B	C	D	E	F
230 V	410 - 420 V	2,33 A (180 Ω)	6,18 A (68 Ω)	10,77 A (39 Ω) 15,56 A (27 Ω)	41,0 A (10 Ω)	60,3 A (6,8 Ω)	124,2 A (3,3 Ω)
400 V	820 - 840 V	2,15 A (390 Ω)	5,25 A (160 Ω)	15 A (56 Ω)	30,4 A (27 Ω)	54,7 A (15 Ω)	100,0 A (8,2 Ω)
575 V	1020 V	-	-	8,5 A (120 Ω) 12,4 A (82 Ω)	26,2 A (39 Ω)	37,8 A (27 Ω)	85,0 A (12 Ω)

Table 5-5 MICROMASTER 440 Specifications

In order that the system is in compliance with UL, UL-certified fuses must be used with the appropriate rated current.

Input voltage range  
(with built in Class A Filter)

1 AC 200 V – 240 V, ± 10 %

Order No.	6SE6440-	2AB11 -2AA1	2AB12 -5AA1	2AB13 -7AA1	2AB15 -5AA1	2AB17 -5AA1	2AB21 -1BA1	2AB21 -5BA1	2AB22 -2BA1	2AB23 -0CA1
Output Rating (CT)	[kW] [hp]	0.12 0.16	0.25 0.33	0.37 0.5	0.55 0.75	0.75 1.0	1.1 1.5	1.5 2.0	2.2 3.0	3.0 4.0
Output Power	[kVA]	0.4	0.7	1.0	1.3	1.7	2.4	3.2	4.6	6.0
CT Input Current 1)	[A]	1.8	3.2	4.6	6.2	8.2	11.0	14.4	20.2	35.5
CT Output Current	[A]	0.9	1.7	2.3	3.0	3.9	5.5	7.4	10.4	13.6
Fuse	[A]	10	10	10	16	16	20	20	32	40
Recommended for UL specified	3NA	3803	3803	3803	3805	3805	3807	3807	3812	3817
		*	*	*	*	*	*	*	*	*
Input Cable Min.	[mm <sup>2</sup> ] [awg]	1.0 18	1.0 18	1.0 18	1.5 16	1.5 16	2.5 14	2.5 14	4.0 12	6.0 10
Input Cable Max.	[mm <sup>2</sup> ] [awg]	2.5 14	2.5 14	2.5 14	2.5 14	2.5 14	6.0 10	6.0 10	6.0 10	10.0 8
Output Cable Min.	[mm <sup>2</sup> ] [awg]	1.0 18	1.0 18	1.0 18	1.0 18	1.0 18	1.0 18	1.0 18	1.0 18	1.5 16
Output Cable Max.	[mm <sup>2</sup> ] [awg]	2.5 14	2.5 14	2.5 14	2.5 14	2.5 14	6.0 10	6.0 10	6.0 10	10.0 8
Weight	[kg] [lbs]	1.3 2.9	1.3 2.9	1.3 2.9	1.3 2.9	1.3 2.9	3.4 7.5	3.4 7.5	3.4 7.5	5.7 12.5

1) Secondary conditions: Input current at the rated operating point - applies for the short-circuit voltage of the line supply  $V_k = 2\%$  referred to the rated drive converter power and a rated line supply voltage of 240 V without line commutating reactor.

\* UL listed fuses such as Class NON from Bussmann are required for use in America

**Input voltage range  
(Unfiltered)****1 AC 200 V – 240 V. ± 10 %**

Order No.	6SE6440-	2UC11 -2AA1	2UC12 -5AA1	2UC13 -7AA1	2UC15 -5AA1	2UC17 -5AA1	2UC21 -1BA1	2UC21 -5BA1	2UC22 -2BA1	2UC23 -0CA1
Output Rating (CT)	[kW] [hp]	0.12 0.16	0.25 0.33	0.37 0.5	0.55 0.75	0.75 1.0	1.1 1.5	1.5 2.0	2.2 3.0	3.0 4.0
Output Power	[kVA]	0.4	0.7	1.0	1.3	1.7	2.4	3.2	4.6	6.0
CT Input Current 1)	[A]	1.8	3.2	4.6	6.2	8.2	11.0	14.4	20.2	35.5
CT Output Current	[A]	0.9	1.7	2.3	3.0	3.9	5.5	7.4	10.4	13.6
Fuse	[A]	10	10	10	16	16	20	20	32	40
Recommended for UL specified	3NA	3803	3803	3803	3805	3805	3807	3807	3812	3817
		*	*	*	*	*	*	*	*	*
Input Cable Min.	[mm <sup>2</sup> ] [awg]	1.0 18	1.0 18	1.0 18	1.5 16	1.5 16	2.5 14	2.5 14	4.0 12	6.0 10
Input Cable Max.	[mm <sup>2</sup> ] [awg]	2.5 14	2.5 14	2.5 14	2.5 14	2.5 14	6.0 10	6.0 10	6.0 10	10.0 8
Output Cable Min.	[mm <sup>2</sup> ] [awg]	1.0 18	1.0 18	1.0 18	1.0 18	1.0 18	1.0 18	1.0 18	1.0 18	1.5 16
Output Cable Max.	[mm <sup>2</sup> ] [awg]	2.5 14	2.5 14	2.5 14	2.5 14	2.5 14	6.0 10	6.0 10	6.0 10	10.0 8
Weight	[kg] [lbs]	1.3 2.9	1.3 2.9	1.3 2.9	1.3 2.9	1.3 2.9	3.3 7.3	3.3 7.3	3.3 7.3	5.5 12.1

**Input voltage range 3 AC 200 V – 240 V. ± 10 %  
(with built in Class A Filter)**

Order No.	6SE6440-	2AC23- 0CA1	2AC24- 0CA1	2AC25- 5CA1
Output Rating (CT)	[kW] [hp]	3.0 4.0	4.0 5.0	5.5 7.5
Output Power	[kVA]	6.0	7.7	9.6
CT Input Current 1)	[A]	15.6	19.7	26.5
CT-Output Current	[A]	13.6	17.5	22.0
VT Input Current 1)	[A]	-	28.3	34.2
VT-Output Current	[A]	-	22.0	28.0
Fuse	[A]	25	32	35
Recommended for UL specified	3NA	3810	3812	3814
		*	*	*
Input Cable Min.	[mm <sup>2</sup> ] [awg]	2.5 14	4.0 12	4.0 12
Input Cable Max.	[mm <sup>2</sup> ] [awg]	10.0 8	10.0 8	10.0 8
Output Cable Min.	[mm <sup>2</sup> ] [awg]	1.5 16	4.0 12	4.0 12
Output Cable Max.	[mm <sup>2</sup> ] [awg]	10.0 8	10.0 8	10.0 8
Weight	[kg] [lbs]	5.7 12.5	5.7 12.5	5.7 12.5

1) Secondary conditions: Input current at the rated operating point - applies for the short-circuit voltage of the line supply  $V_k = 2\%$  referred to the rated drive converter power and a rated line supply voltage of 240 V without line commutating reactor.

\* UL listed fuses such as Class NON from Bussmann are required for use in America

Input voltage range  
(Unfiltered)3 AC 200 V – 240 V.  $\pm 10\%$ 

Order No.	6SE6440-	2UC11-2AA1	2UC12-5AA1	2UC13-7AA1	2UC15-5AA1	2UC17-5AA1	2UC21-1BA1	2UC21-5BA1	2UC22-2BA1	2UC23-0CA1
Output Rating (CT)	[kW] [hp]	0.12 0.16	0.25 0.33	0.37 0.5	0.55 0.75	0.75 1.0	1.1 1.5	1.5 2.0	2.2 3.0	3.0 4.0
Output Power	[kVA]	0.4	0.7	1.0	1.3	1.7	2.4	3.2	4.6	6.0
CT Input Current 1)	[A]	1.1	1.9	2.7	3.6	4.7	6.4	8.3	11.7	15.6
CT Output Current	[A]	0.9	1.7	2.3	3.0	3.9	5.5	7.4	10.4	13.6
Fuse	[A]	10	10	10	16	16	20	20	25	25
Recommended for UL specified	3NA	3803	3803	3803	3805	3805	3807	3807	3810	3810
		*	*	*	*	*	*	*	*	*
Input Cable Min.	[mm <sup>2</sup> ] [awg]	1.0 18	1.0 18	1.0 18	1.5 16	1.5 16	2.5 14	2.5 14	2.5 14	4.0 12
Input Cable Max.	[mm <sup>2</sup> ] [awg]	2.5 14	2.5 14	2.5 14	2.5 14	2.5 14	6.0 10	6.0 10	6.0 10	10.0 8
Output Cable Min.	[mm <sup>2</sup> ] [awg]	1.0 18	1.0 18	1.0 18	1.0 18	1.0 18	1.0 18	1.0 18	1.0 18	1.5 16
Output Cable Max.	[mm <sup>2</sup> ] [awg]	2.5 14	2.5 14	2.5 14	2.5 14	2.5 14	6.0 10	6.0 10	6.0 10	10.0 8
Weight	[kg] [lbs]	1.3 2.9	1.3 2.9	1.3 2.9	1.3 2.9	1.3 2.9	3.3 7.3	3.3 7.3	3.3 7.3	5.5 12.1

Order No.	6SE6440-	2UC24-0CA1	2UC25-5CA1	2UC27-5DA1	2UC31-1DA1	2UC31-5DA1	2UC31-8EA1	2UC32-2EA1	2UC33-0FA1	2UC33-7FA1	2UC34-5FA1
Output Rating (CT)	[kW] [hp]	4.0 5.0	5.5 7.5	7.5 10.0	11.0 15.0	15.0 20.0	18.5 25.0	22.0 30.0	30.0 40.0	37.0 50.0	45.0 60.0
Output Power	[kVA]	7.7	9.6	12.3	18.4	23.7	29.8	35.1	45.6	57.0	67.5
CT Input Current 1)	[A]	19.7	26.5	34.2	38.0	50.0	62.0	71.0	96.0	114.0	135.0
CT-Output Current	[A]	17.5	22.0	28.0	42.0	54.0	68.0	80.0	104.0	130.0	154.0
VT Input Current 1)	[A]	28.3	34.2	38.0	50.0	62.0	71.0	96.0	114.0	135.0	164.0
VT-Output Current	[A]	22.0	28.0	42.0	54.0	68.0	80.0	104.0	130.0	154.0	178.0
Fuse	[A]	32	35	50	80	80	100	125	200	200	250
Recommended for UL specified	3NA	3812	3814	3820	3824	3824	3830	3832	3140	3142	3144
	3NE	*	*	1817-0	1820-0	1820-0	1021-0	1022-0	1225-0	1225-0	1227-0
Input Cable Min.	[mm <sup>2</sup> ] [awg]	4.0 12	4.0 12	10.0 8	16.0 6	16.0 6	25.0 3	25.0 3	70.0 2/0	70.0 2/0	95.0 3/0
Input Cable Max.	[mm <sup>2</sup> ] [awg]	10.0 8	10.0 8	35.0 2	35.0 2	35.0 2	35.0 2	35.0 2	150.0 300	150.0 300	150.0 300
Output Cable Min.	[mm <sup>2</sup> ] [awg]	4.0 12	4.0 12	10.0 8	16.0 6	16.0 6	25.0 3	25.0 3	50.0 1/0	70.0 2/0	95.0 3/0
Output Cable Max.	[mm <sup>2</sup> ] [awg]	10.0 8	10.0 8	35.0 2	35.0 2	35.0 2	35.0 2	35.0 2	150.0 300	150.0 300	150.0 300
Weight	[kg] [lbs]	5.5 12.1	5.5 12.1	17.0 37.0	16.0 35.0	16.0 35.0	20.0 44.0	20.0 44.0	55.0 121.0	55.0 121.0	55.0 121.0

1) Secondary conditions: Input current at the rated operating point - applies for the short-circuit voltage of the line supply  $V_k = 2\%$  referred to the rated drive converter power and a rated line supply voltage of 240 V without line commutating reactor.

\* UL listed fuses such as Class NON from Bussmann are required for use in America

**Input voltage range  
(with built in Class A Filter)**
**3 AC 380 V – 480 V. ± 10 %**

Order No.	6SE6440-	2AD22-2BA1	2AD23-0BA1	2AD24-0BA1	2AD25-5CA1	2AD27-5CA1	2AD31-1CA1	2AD31-5DA1
Output Rating (CT)	[kW]	2.2	3.0	4.0	5.5	7.5	11.0	15.0
	[hp]	3.0	4.0	5.0	7.5	10.0	15.0	20.0
Output Power	[kVA]	4.5	5.9	7.8	10.1	14.0	19.8	24.4
CT-Input Current 1)	[A]	7.5	10.0	12.8	15.6	22.0	23.1	33.8
CT Output Current	[A]	5.9	7.7	10.2	13.2	18.4	26.0	32.0
VT Input Current 1)	[A]	–	–	–	17.3	23.1	33.8	37.0
VT-Output Current	[A]	–	–	–	20.2	29.0	39.0	45.2
Fuse Recommended for UL specified	[A]	16	16	20	20	32	35	50
	3NA	3805	3805	3807	3807	3812	3814	3820
	3NE	*	*	*	*	*	*	1817-0
Input Cable Min.	[mm <sup>2</sup> ]	1.5	1.5	2.5	2.5	4.0	6.0	10.0
	[awg]	16	16	14	14	12	10	8
Input Cable Max.	[mm <sup>2</sup> ]	6.0	6.0	6.0	10.0	10.0	10.0	35.0
	[awg]	10	10	10	8	8	8	2
Output Cable Min.	[mm <sup>2</sup> ]	1.0	1.0	1.0	2.5	4.0	6.0	10.0
	[awg]	18	18	18	14	12	10	8
Output Cable Max.	[mm <sup>2</sup> ]	6.0	6.0	6.0	10.0	10.0	10.0	35.0
	[awg]	10	10	10	8	8	8	2
Weight	[kg]	3.4	3.4	3.4	5.7	5.7	5.7	17.0
	[lbs]	7.5	7.5	7.5	12.5	12.5	12.5	37.0

Order No.	6SE6440-	2AD31-8DA1	2AD32-2DA1	2AD33-0EA1	2AD33-7EA1	2AD34-5FA1	2AD35-5FA1	2AD37-5FA1
Output Rating (CT)	[kW]	18.5	22.0	30.0	37.0	45.0	55.0	75.0
	[hp]	25.0	30.0	40.0	50.0	60.0	75.0	100.0
Output Power	[kVA]	29.0	34.3	47.3	57.2	68.6	83.8	110.5
CT-Input Current 1)	[A]	37.0	43.0	59.0	72.0	87.0	104.0	139.0
CT Output Current	[A]	38.0	45.0	62.0	75.0	90.0	110.0	145.0
VT Input Current 1)	[A]	43.0	59.0	72.0	87.0	104.0	139.0	169.0
VT-Output Current	[A]	45.0	62.0	75.0	90.0	110.0	145.0	178.0
Fuse Recommended for UL specified	[A]	63	80	100	125	160	200	250
	3NA	3822	3824	3830	3832	3836	3140	3144
	3NE	1818-0	1820-0	1021-0	1022-0	1224-0	1225-0	1227-0
Input Cable Min.	[mm <sup>2</sup> ]	10.0	16.0	25.0	25.0	35.0	70.0	95.0
	[awg]	8	6	3	3	2	2/0	3/0
Input Cable Max.	[mm <sup>2</sup> ]	35.0	35.0	35.0	35.0	150.0	150.0	150.0
	[awg]	2	2	2	2	300	300	300
Output Cable Min.	[mm <sup>2</sup> ]	10.0	16.0	25.0	25.0	50.0	70.0	95.0
	[awg]	8	6	3	3	1/0	2/0	3/0
Output Cable Max.	[mm <sup>2</sup> ]	35.0	35.0	35.0	35.0	150.0	150.0	150.0
	[awg]	2	2	2	2	300	300	300
Weight	[kg]	17.0	17.0	22.0	22.0	75.0	75.0	75.0
	[lbs]	37.0	37.0	48.0	48.0	165.0	165.0	165.0

1) Secondary conditions: Input current at the rated operating point - applies for the short-circuit voltage of the line supply  $V_k = 2\%$  referred to the rated drive converter power and a rated line supply voltage of 400 V without line commutating reactor.

\* UL listed fuses such as Class NON from Bussmann are required for use in America

Input voltage range  
(Unfiltered)

3 AC 380 V – 480 V. ± 10 %

Order No.	6SE6440-	2UD13 -7AA1	2UD15 -5AA1	2UD17 -5AA1	2UD21 -1AA1	2UD21 -5AA1	2UD22 -2BA1	2UD23 -0BA1	2UD24 -0BA1	2UD25 -5CA1	2UD27 -5CA1
Output Rating (CT)	[kW] [hp]	0.37 0.5	0.55 0.75	0.75 1.0	1.1 1.5	1.5 2.0	2.2 3.0	3.0 4.0	4.0 5.0	5.5 7.5	7.5 10.0
Output Power	[kVA]	0.9	1.2	1.6	2.3	3.0	4.5	5.9	7.8	10.1	14.0
CT Input Current 1)	[A]	2.2	2.8	3.7	4.9	5.9	7.5	10.0	12.8	15.6	22.0
CT Output Current	[A]	1.3	1.7	2.2	3.1	4.1	5.9	7.7	10.2	13.2	19.0
VT Input Current 1)	[A]	–	–	–	–	–	–	–	–	17.3	23.1
VT-Output Current	[A]	–	–	–	–	–	–	–	–	19.0	26.0
Fuse	[A]	10	10	10	10	10	16	16	20	20	32
Recommended for UL specified	3NA	3803	3803	3803	3803	3803	3805	3805	3807	3807	3812
		*	*	*	*	*	*	*	*	*	*
Input Cable Min.	[mm <sup>2</sup> ] [awg]	1.0 18	1.0 18	1.0 18	1.0 18	1.0 18	1.5 16	1.5 16	2.5 14	2.5 14	4.0 12
Input Cable Max.	[mm <sup>2</sup> ] [awg]	2.5 14	2.5 14	2.5 14	2.5 14	2.5 14	6.0 10	6.0 10	6.0 10	10.0 8	10.0 8
Output Cable Min.	[mm <sup>2</sup> ] [awg]	1.0 18	1.0 18	1.0 18	1.0 18	1.0 18	1.0 18	1.0 18	1.0 18	2.5 14	4.0 12
Output Cable Max.	[mm <sup>2</sup> ] [awg]	2.5 14	2.5 14	2.5 14	2.5 14	2.5 14	6.0 10	6.0 10	6.0 10	10.0 8	10.0 8
Weight	[kg] [lbs]	1.3 2.9	1.3 2.9	1.3 2.9	1.3 2.9	1.3 2.9	3.3 7.3	3.3 7.3	3.3 7.3	5.5 12.1	5.5 12.1

Order No.	6SE6440-	2UD31 -1CA1	2UD31 -5DA1	2UD31 -8DA1	2UD32 -2DA1	2UD33 -0EA1	2UD33 -7EA1	2UD34 -5FA1	2UD35 -5FA1	2UD37 -5FA1
Output Rating (CT)	[kW] [hp]	11.0 15.0	15.0 20.0	18.5 25.0	22.0 30.0	30.0 40.0	37.0 50.0	45.0 60.0	55.0 75.0	75.0 100.0
Output Power	[kVA]	19.8	24.4	29.0	34.3	47.3	57.2	68.6	83.8	110.5
CT Input Current 1)	[A]	23.1	33.8	37.0	43.0	59.0	72.0	87.0	104.0	139.0
CT Output Current	[A]	26.0	32.0	38.0	45.0	62.0	75.0	90.0	110.0	145.0
VT Input Current 1)	[A]	33.8	37.0	43.0	59.0	72.0	87.0	104.0	139.0	169.0
VT-Output Current	[A]	32.0	38.0	45.0	62.0	75.0	90.0	110.0	145.0	178.0
Fuse	[A]	35	50	63	80	100	125	160	200	250
Recommended for UL specified	3NA	3814	3820	3822	3824	3830	3832	3836	3140	3144
	3NE	–	1817-0	1818-0	1820-0	1021-0	1022-0	1224-0	1225-0	1227-0
Input Cable Min.	[mm <sup>2</sup> ] [awg]	6.0 10	10.0 8	10.0 8	16.0 6	25.0 3	25.0 3	35.0 2	70.0 2/0	95.0 3/0
Input Cable Max.	[mm <sup>2</sup> ] [awg]	10.0 8	35.0 2	35.0 2	35.0 2	35.0 2	35.0 2	150.0 300	150.0 300	150.0 300
Output Cable Min.	[mm <sup>2</sup> ] [awg]	6.0 10	10.0 8	10.0 8	16.0 6	25.0 3	25.0 3	35.0 2	70.0 2/0	95.0 3/0
Output Cable Max.	[mm <sup>2</sup> ] [awg]	10.0 8	35.0 2	35.0 2	35.0 2	35.0 2	35.0 2	150.0 300	150.0 300	150.0 300
Weight	[kg] [lbs]	5.5 12.1	16.0 35.0	16.0 35.0	16.0 35.0	20.0 44.0	20.0 44.0	56.0 123.0	56.0 123.0	56.0 123.0

1) Secondary conditions: Input current at the rated operating point - applies for the short-circuit voltage of the line supply  $V_k = 2\%$  referred to the rated drive converter power and a rated line supply voltage of 400 V without line commutating reactor.

\* UL listed fuses such as Class NON from Bussmann are required for use in America

**Input voltage range  
(Unfiltered)**
**3 AC 380 V – 480 V ± 10 %**

Order No.	6SE6440-	2UD38-8FA1	2UD41-1FA1	2UD41-3GA1	2UD41-6GA1	2UD42-0GA1
Output Rating (CT)	[kW]	90	110	132	160	200
	[hp]	125	150	200	250	300
Output Power	[kVA]	145.4	180	214.8	263.2	339.4
CT Input Current 1)	[A]	169	205	245	297	354
CT Output Current	[A]	178	205	250	302	370
VT Input Current 1)	[A]	205	245	297	354	442
VT Output Current	[A]	205	250	302	370	477
Recommended Fuse	[A]	250	315	400	450	560
	3NE	1227-0	1230-0	1332-0	1333-0	1435-0
Pipe cable shoe to DIN 46235	[mm]	10	10	10	10	10
Input Cable Min.	[mm <sup>2</sup> ]	1 x 95 or 2 x 35	1 x 150 or 2 x 50	1 x 185 or 2 x 70	1 x 240 or 2 x 70	2 x 95
	[awg] or [kcmil]	1 x 4/0 or 2 x 2	1 x 300 or 2 x 1/0	1 x 400 or 2 x 2/0	1 x 500 or 2 x 2/0	2 x 4/0
Input Cable Max.	[mm <sup>2</sup> ]	1 x 185 or 2 x 120	1 x 185 or 2 x 120	2 x 240	2 x 240	2 x 240
	[awg] or [kcmil]	1 x 350 or 2 x 4/0	1 x 350 or 2 x 4/0	2 x 400	2 x 400	2 x 400
Output Cable Min.	[mm <sup>2</sup> ]	1 x 95 or 2 x 35	1 x 150 or 2 x 50	1 x 185 or 2 x 70	1 x 240 or 2 x 70	2 x 95
	[awg] or [kcmil]	1 x 4/0 or 2 x 2	1 x 300 or 2 x 1/0	1 x 400 or 2 x 2/0	1 x 500 or 2 x 2/0	2 x 4/0
Output Cable Max.	[mm <sup>2</sup> ]	1 x 185 or 2 x 120	1 x 185 or 2 x 120	2 x 240	2 x 240	2 x 240
	[awg] or [kcmil]	1 x 350 or 2 x 4/0	1 x 350 or 2 x 4/0	2 x 400	2 x 400	2 x 400
Weight	[kg]	110	110	170	170	170
	[lbs]	242	242	418	418	418

- 1) Secondary conditions: Input current at the rated operating point - applies for the short-circuit voltage of the line supply  $V_s \geq 2.33\%$  referred to the rated drive converter power and a rated line supply voltage of 400 V without line commutating reactor.

## Input voltage range

## 3 AC 500 V – 600 V ± 10 % (Unfiltered)

Order No.	6SE6440 -	2UE17-5CA1	2UE21-5CA1	2UE22-2CA1	2UE24-0CA1	2UE25-5CA1	2UE27-5CA1	2UE31-1CA1	2UE31-5DA1	
Output Rating (CT)	[kW]	0.75	1.5	2.2	4.0	5.5	7.5	11.0	15.0	
	[hp]	1.0	2.0	3.0	5.0	7.5	10.0	15.0	20.0	
Output Power	[kVA]	1.3	2.6	3.7	5.8	8.6	10.5	16.2	21.0	
CT Input Current 1)	[A]	2.0	3.7	5.3	8.1	11.1	14.4	21.5	24.9	
CT Output Current	[A]	1.4	2.7	3.9	6.1	9.0	11.0	17.0	22.0	
VT Input Current 1)	[A]	3.2	4.4	6.9	9.4	12.6	18.1	24.9	30.0	
VT-Output Current	[A]	2.7	3.9	6.1	9.0	11.0	17.0	22.0	27.0	
Fuse	[A]	10	10	10	16	16	25	32	35	
	Recommended	3NA	3803-6	3803-6	3803-6	3805-6	3805-6	3810-6	3812-6	3814-6
	for UL specified	3NE	*	*	*	*	*	*	*	1803-0
Input Cable Min.	[mm <sup>2</sup> ]	1.0	1.0	1.0	1.5	1.5	2.5	4.0	6.0	
	[awg]	18	18	18	16	16	14	12	10	
Input Cable Max.	[mm <sup>2</sup> ]	10.0	10.0	10.0	10.0	10.0	10.0	10.0	35.0	
	[awg]	8	8	8	8	8	8	8	2	
Output Cable Min.	[mm <sup>2</sup> ]	1.0	1.0	1.0	1.0	1.0	2.5	4.0	4.0	
	[awg]	18	18	18	18	18	14	12	12	
Output Cable Max.	[mm <sup>2</sup> ]	10.0	10.0	10.0	10.0	10.0	10.0	10.0	35.0	
	[awg]	8	8	8	8	8	8	8	2	
Weight	[kg]	5.5	5.5	5.5	5.5	5.5	5.5	5.5	16.0	
	[lbs]	12.1	12.1	12.1	12.1	12.1	12.1	12.1	35.0	

Order No.	6SE6440-	2UE31-8DA1	2UE32-2DA1	2UE33-0EA1	2UE33-7EA1	2UE34-5FA1	2UE35-5FA1	2UE37-5FA1	
Output Rating (CT)	[kW]	18.5	22.0	30.0	37.0	45.0	55.0	75.0	
	[hp]	25.0	30.0	40.0	50.0	60.0	75.0	100.0	
Output Power	[kVA]	25.7	30.5	39.1	49.5	59.1	73.4	94.3	
CT Input Current 1)	[A]	30.0	35.0	48.0	58.0	69.0	83.0	113.0	
CT Output Current	[A]	27.0	32.0	41.0	52.0	62.0	77.0	99.0	
VT Input Current 1)	[A]	35.0	48.0	58.0	69.0	83.0	113.0	138.0	
VT-Output Current	[A]	32.0	41.0	52.0	62.0	77.0	99.0	125.0	
Fuse	[A]	50	63	80	80	125	160	160	
	Recommended	3NA	3820-6	3822-6	3824-6	3824-6	3132-6	3136-6	3136-6
	for UL specified	3NE	1817-0	1818-0	1820-0	1820-0	1022-0	1224-0	1224-0
Input Cable Min.	[mm <sup>2</sup> ]	10.0	10.0	16.0	25.0	25.0	50.0	50.0	
	[awg]	8	8	6	3	3	1/0	1/0	
Input Cable Max.	[mm <sup>2</sup> ]	35.0	35.0	35.0	35.0	150.0	150.0	150.0	
	[awg]	2	2	2	2	300	300	300	
Output Cable Min.	[mm <sup>2</sup> ]	6.0	10.0	16.0	16.0	25.0	35.0	50.0	
	[awg]	10	8	6	6	3	2	1/0	
Output Cable Max.	[mm <sup>2</sup> ]	35.0	35.0	35.0	35.0	150.0	150.0	150.0	
	[awg]	2	2	2	2	300	300	300	
Weight	[kg]	16.0	16.0	20.0	20.0	56.0	56.0	56.0	
	[lbs]	35.0	35.0	44.0	44.0	123.0	123.0	123.0	

1) Secondary conditions: Input current at the rated operating point - applies for the short-circuit voltage of the line supply  $V_k = 2\%$  referred to the rated drive converter power and a rated line supply voltage of 500 V without line commutating reactor.

\* UL listed fuses such as Class NON from Bussmann are required for use in America

## 6 Options

An overview of the options available for the MICROMASTER 440 is given in this section. For further information about options, please refer to the catalog or the documentation CD.

### 6.1 Inverter-independent options

- Basic Operator Panel (BOP)
- Advanced Operator Panel (AOP)
- DeviceNet module
- CANopen option module
- Pulse encoder evaluation module
- PROFIBUS module
- PC to inverter connection kit
- PC to AOP connection kit
- Operator panel door mounting kit for single inverter control
- AOP door mounting kit for multiple inverter control
- "DriveMonitor" and "Starter" commissioning tool

## 6.2 Inverter-dependent options

### Frame Sizes A to F

- EMC filter. Class A
- EMC filter. Class B
- Additional EMC filter. Class B
- Low leakage Class B filter
- Line commutating choke
- Output choke
- Gland plate
- LC filter

---

#### CAUTION

When using output reactors and LC filters, operation up to a pulse frequency of **4 kHz** only is permitted. Please ensure that the automatic pulse frequency reductions are also deactivated. **Mandatory** parameter settings when using an output reactor: **P1800 = 4 kHz** , **P0290 = 0 or 1**.

---

### Frame Sizes FX and GX

- Line commutating choke
- EMC filter. Class A (power commutating choke required)
- LC filter

---

#### CAUTION

When using output reactors and LC filters, operation up to a pulse frequency of **4 kHz** only is permitted. Please ensure that the automatic pulse frequency reductions are also deactivated. **Mandatory** parameter settings when using an output reactor: **P1800 = 4 kHz** , **P0290 = 0 or 1**.

---

## 7 Electro-magnetic compatibility (EMC)

**This Chapter contains:**

EMC information.

7.1	Electro-magnetic compatibility .....	276
-----	--------------------------------------	-----

www.ElectricalPartManuals.com

## 7.1 Electro-magnetic compatibility

(EMC) All manufacturers / assemblers of electrical apparatus which “performs a complete intrinsic function and is placed on the market as a single unit intended for the end user” must comply with the EMC directive 89/336/EEC.

There are three routes for the manufacturer/assembler to demonstrate compliance:

### 7.1.1 Self-certification

This is a manufacturer's declaration that the European standards applicable to the electrical environment for which the apparatus is intended have been met. Only standards that have been officially published in the Official Journal of the European Community can be cited in the manufacturer's declaration.

### 7.1.2 Technical construction file

A technical construction file can be prepared for the apparatus describing its EMC characteristics. This file must be approved by a ‘Competent Body’ appointed by the appropriate European government organization. This approach allows the use of standards that are still in preparation.

### 7.1.3 EC type examination certificate

This approach is only applicable to radio communication transmitting apparatus. All MICROMASTER 440 units are certified for compliance with the EMC directive. when installed in accordance with the recommendations in Section 2.

### 7.1.4 EMC Directive Compliance with Imminent Harmonics Regulations

From 1st January 2001 all electrical apparatus covered by the EMC Directive will have to comply with EN 61000-3-2 "Limits for harmonic current emissions (equipment input  $\leq 16$  A per phase)".

All Siemens variable speed drives of the MICROMASTER, MIDIMASTER, MICROMASTER Eco and COMBIMASTER ranges, which are classified as "Professional Equipment" within the terms of the standard, fulfill the requirements of the standard.

The allowed harmonic currents for "professional equipment" with an input power  $> 1$  kW are not yet defined. Therefore, any electrical apparatus containing the above drives which has an input power  $> 1$  kW will not require connection approval.

#### Only Frame Sizes A to C

Special considerations for 250 W to 550 W drives with 230 V 1ac mains supplies when used in non-industrial applications:

Units in this voltage and power range will be supplied with the following warning:

*"This equipment requires supply authority acceptance for connection to the public supply network".* Please refer to EN 61000-3-12 sections 5.3 and 6.4 for further information. Units connected to Industrial Networks<sup>1</sup> do not require connection approval (see EN 61800-3, section 6.1.2.2).

The harmonic current emissions from these products are described in the table below:

Table 7-1 Permissible harmonic current emissions

Rating	Typical Harmonic Current (A)					Typical Harmonic Current (%)					Typical Voltage Distortion		
											Distribution Transformer Rating		
	3 <sup>rd</sup>	5 <sup>th</sup>	7 <sup>th</sup>	9 <sup>th</sup>	11 <sup>th</sup>	3 <sup>rd</sup>	5 <sup>th</sup>	7 <sup>th</sup>	9 <sup>th</sup>	11 <sup>th</sup>	10 kVA	100 kVA	1 MVA
250 W 1AC 230 V	2.15	1.44	0.72	0.26	0.19	83	56	28	10	7	0.77	0.077	0.008
370 W 1AC 230 V	2.96	2.02	1.05	0.38	0.24	83	56	28	10	7	1.1	0.11	0.011
550 W 1AC 230 V	4.04	2.70	1.36	0.48	0.36	83	56	28	10	7	1.5	0.15	0.015

#### NOTE

The allowed harmonic currents for "professional equipment" with an input power  $> 1$  kW are not yet defined. Therefore, any electrical apparatus containing the above drives which has an input power  $> 1$  kW will not require connection approval.

Alternatively, the necessity to apply for connection approval can be avoided by fitting the input chokes recommended in the technical catalogues (except 550 W 230 V 1ac units).

<sup>1</sup> Industrial Networks are defined as those which do not supply buildings used for domestic purposes.

### 7.1.5 Classification of EMC performance

General classes of EMC performance are available as detailed below:

#### Class 1: General Industrial

Compliance with European Standard EN 61800-3 (EMC Product Standard for Power Drive Systems) for use in **Second Environment (Industrial)**.

Table 7-2 General industrial application

EMC Phenomenon		Standard	Level
<b>Emissions:</b>	Radiated emissions	EN 55011	Level A1
	Conducted emissions	EN 61800-3	Limits complying with EN 55011, Class A, Group 2
<b>Immunity:</b>	Electrostatic discharge	EN 61000-4-2	8 kV air discharge
	Burst interference	EN 61000-4-4	2 kV power cables, 1 kV control cables
	Radio-frequency electromagnetic field	EN 61000-4-3	26–1000 MHz, 10 V/m

#### Class 2: Industrial application with filter

This level of EMC performance will allow the manufacturer/installer to certify their equipment themselves for compliance with the EMC directive for the industrial environment, as far as the EMC performance characteristics of the power drive system are concerned. Performance limits are as specified in the Generic Industrial Emissions and Immunity Standards EN 61000-6-4 und EN 61000-6-2.

Table 7-3 With filter, for industrial applications

EMC Phenomenon		Standard	Level
<b>Emissions:</b>	Radiated emissions	EN 55011	Level A1
	Conducted emissions	EN 61800-3	Limits complying with EN 55011, Class A, Group 2
<b>Immunity:</b>	Supply voltage distortion	EN 61000-2-4	
	Voltage fluctuations, dips, unbalance, frequency variations	EN 61000-2-1	
	Magnetic fields	EN 61000-4-8	50 Hz, 30 A/m
	Electrostatic discharge	EN 61000-4-2	8 kV air discharge
	Burst interference	EN 61000-4-4	2 kV power cables, 2 kV control cables
	Radio-frequency electromagnetic field, amplitude-modulated	EN 61000-4-3	80–1000 MHz, 10 V/m, 80% AM, power and signal lines
	Radio-frequency electromagnetic field, pulse-modulated	EN 61000-4-3	900 MHz, 10 V/m 50 % duty cycle, repetition rate 200 Hz

## Only Frame Sizes A to F

### Class 3: With filter, for residential, commercial and trade applications

This level of EMC performance will allow the manufacturer/installer to certify compliance of their equipment themselves with the EMC directive for the residential, commercial and light industrial environment, as far as the EMC performance characteristics of the power drive system are concerned. Performance limits are as specified in the Generic Emission and Immunity Standards EN 61000-6-3 and EN 61000-6-1 in residential applications.

Table 7-4 With filter, for residential, commercial and trade applications

EMC Phenomenon		Standard	Level
<b>Emissions:</b>	Radiated emissions*	EN 55011	Level B
	Conducted emissions	EN 61800-3	Category C1: Limit complying with EN 55011, Class B Category C2: Limit complying with EN 55011, Class A
<b>Immunity:</b>	Supply voltage distortion	EN 61000-2-4	
	Voltage fluctuations, dips, unbalance, frequency variations	EN 61000-2-1	
	Magnetic fields	EN 61000-4-8	50 Hz, 30 A/m
	Electrostatic discharge	EN 61000-4-2	8 kV air discharge
	Burst interference	EN 61000-4-4	2 kV power cables, 2 kV control cables
	Radio-frequency electro-magnetic field, amplitude-modulated	EN 61000-4-3	80–1000 MHz, 10 V/m, 80 % AM, power and signal lines
	Radio-frequency electro-magnetic field, pulse-modulated	EN 61000-4-3	900 MHz, 10 V/m 50 % duty cycle, repetition rate 200 Hz

\* These limits are dependent on the inverter being correctly installed inside a metallic switchgear enclosure. The limits will not be met if the inverter is not enclosed.

#### NOTES

- To achieve these performance levels, you must not exceed the default Pulse frequency nor use cables longer than 25 m.
- The MICROMASTER inverters are intended **exclusively for professional applications**. Therefore, they do not fall within the scope of the harmonics emissions specification EN 61000-3-2.
- Maximum mains supply voltage when filters are fitted is 460 V.

Table 7-5 Compliance Table

**Frame Sizes A to F**

Model	Remarks
<b>Class 1 – General industrial application</b>	
6SE6440-2U***-**A1	Units without filters, all voltages and performances. The product norm EN 61800-3 +A11 for "Variable-speed electrical drives, Part 3: EMC product standard including specific test methods" specifies limits for conducted emissions which cannot be complied with by unfiltered inverters in the second environment. Filtered inverters (as described under Class 2) must be installed for drive systems in C3 installations. The use of unfiltered inverters in industrial environments is allowed only if they are part of a system which is equipped with line filters on the higher-level supply side.
<b>Class 2 – With filter, for industrial application</b>	
6SE6440-2A***-**A1	All units with integral Class A filters
6SE6440-2A***-**A1 with 6SE6440-2FA00-6AD1	Frame size A units 400 - 480 V with external Class A footprint filters
<b>Class 3 – With filter, for residential, commercial and trade applications</b>	
6SE6440-2U***-**A1 with 6SE6400-2FB0*-***0	Units without filter fitted with external Class B footprint filters.
6SE6440-2A***-**A1 with 6SE6400-2FS0*-***0 or 6SE6400-2FL0*-***0	Units with fitted Class A filters and additional external Class B filters.
6SE6440-2U***-**A0 with EMC filter Class B (e.g. Fa. Schaffner) 6SE6440-2A***-**A0	Units without filter fitted with external Class A footprint filters.  All units with fitted Class A filters. For drive systems in category C2 installations, the following warning notice is necessary: In residential environments, this product may cause radio-frequency disturbances which may necessitate interference suppression measures.
* denotes any value is allowed.	

**Frame Sizes FX to GX**

Model	Remarks
<b>Class 1 – General industrial application</b>	
6SE6440-2U***-**A1	Units without filters, all voltages and performances. The product norm EN 61800-3 +A11 for "Variable-speed electrical drives, Part 3: EMC product standard including specific test methods" specifies limits for conducted emissions which cannot be complied with by unfiltered inverters in the second environment. Filtered inverters (as described under Class 2) must be installed for drive systems in C3 installations. The use of unfiltered inverters in industrial environments is allowed only if they are part of a system which is equipped with line filters on the higher-level supply side.
<b>Class 2 – With filter, for industrial application</b>	
6SE6440-2U***-**A1	With external EMI filter (available as an option) the limiting values of the EN 55011. Class A are fulfilled for conducted emission. (line commutating choke required)

Category C3: Drive system (PDS) with rated voltage < 1000 V. For use in second environment.

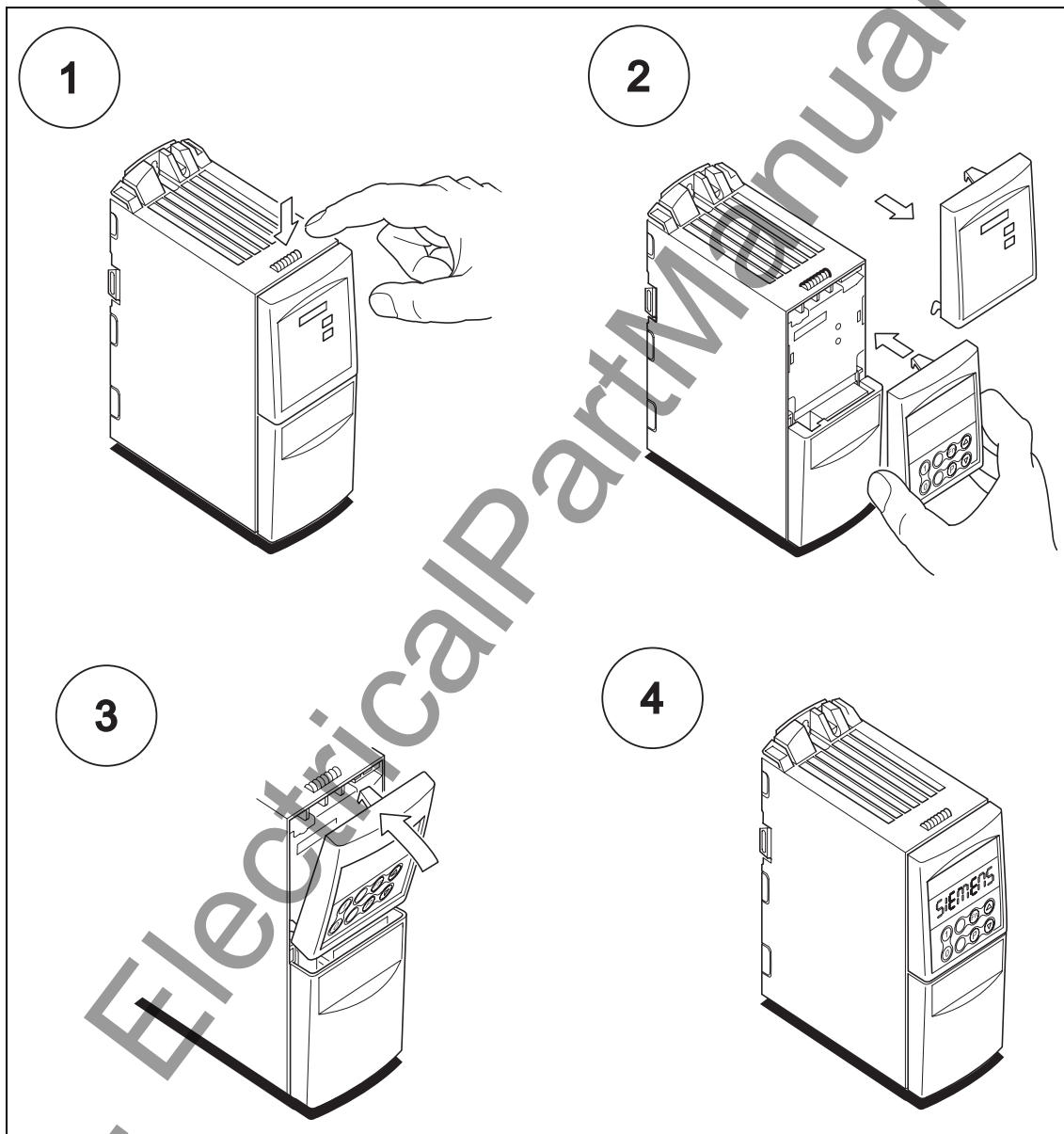
Category C2: Drive system (PDS) with rated voltage < 1000 V.

For use in first environment. Installation and commissioning by EMC expert only.

Category C1: Drive system (PDS) with rated voltage < 1000 V. For use in first environment.

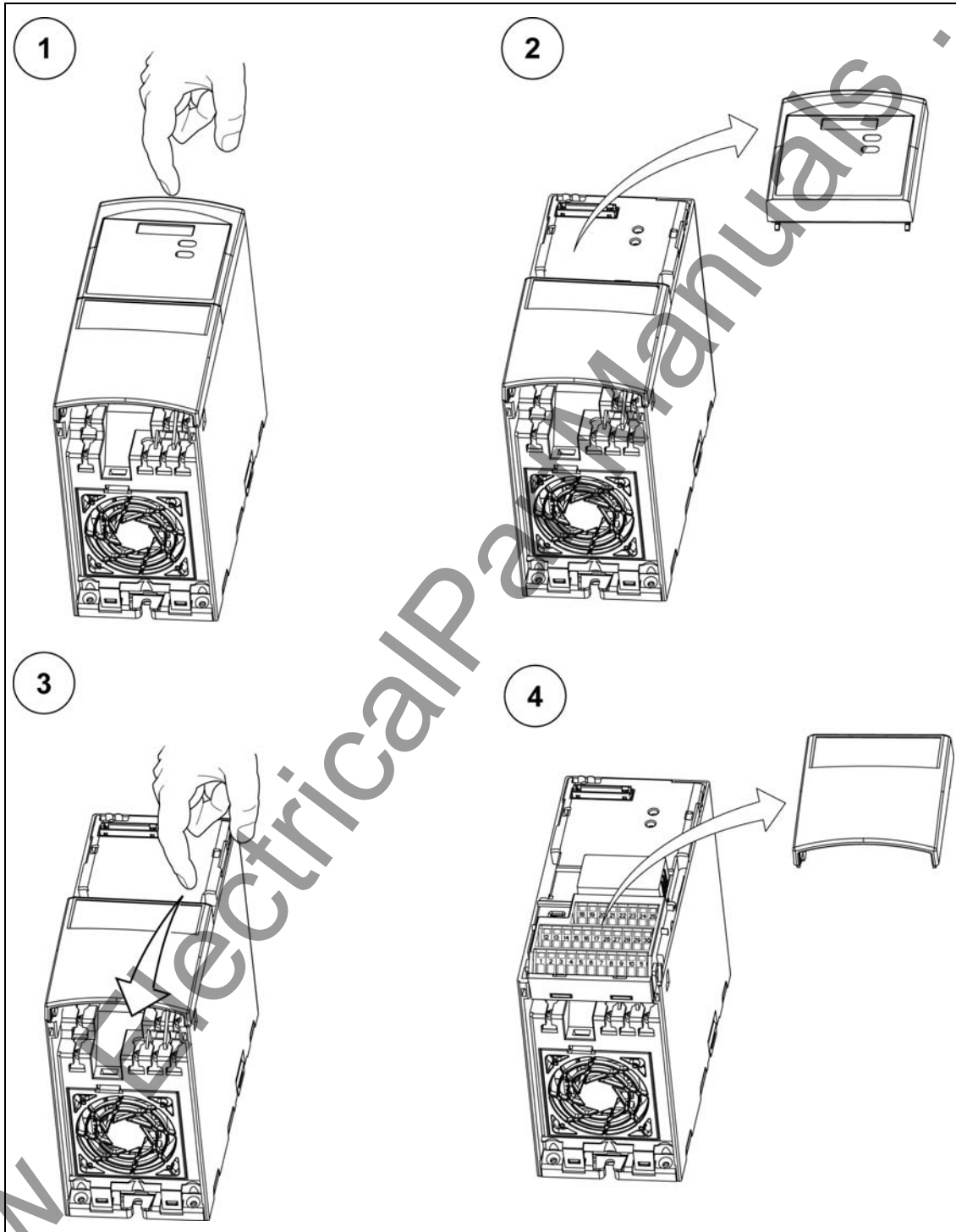
## Appendices

### A Changing the Operator Panel

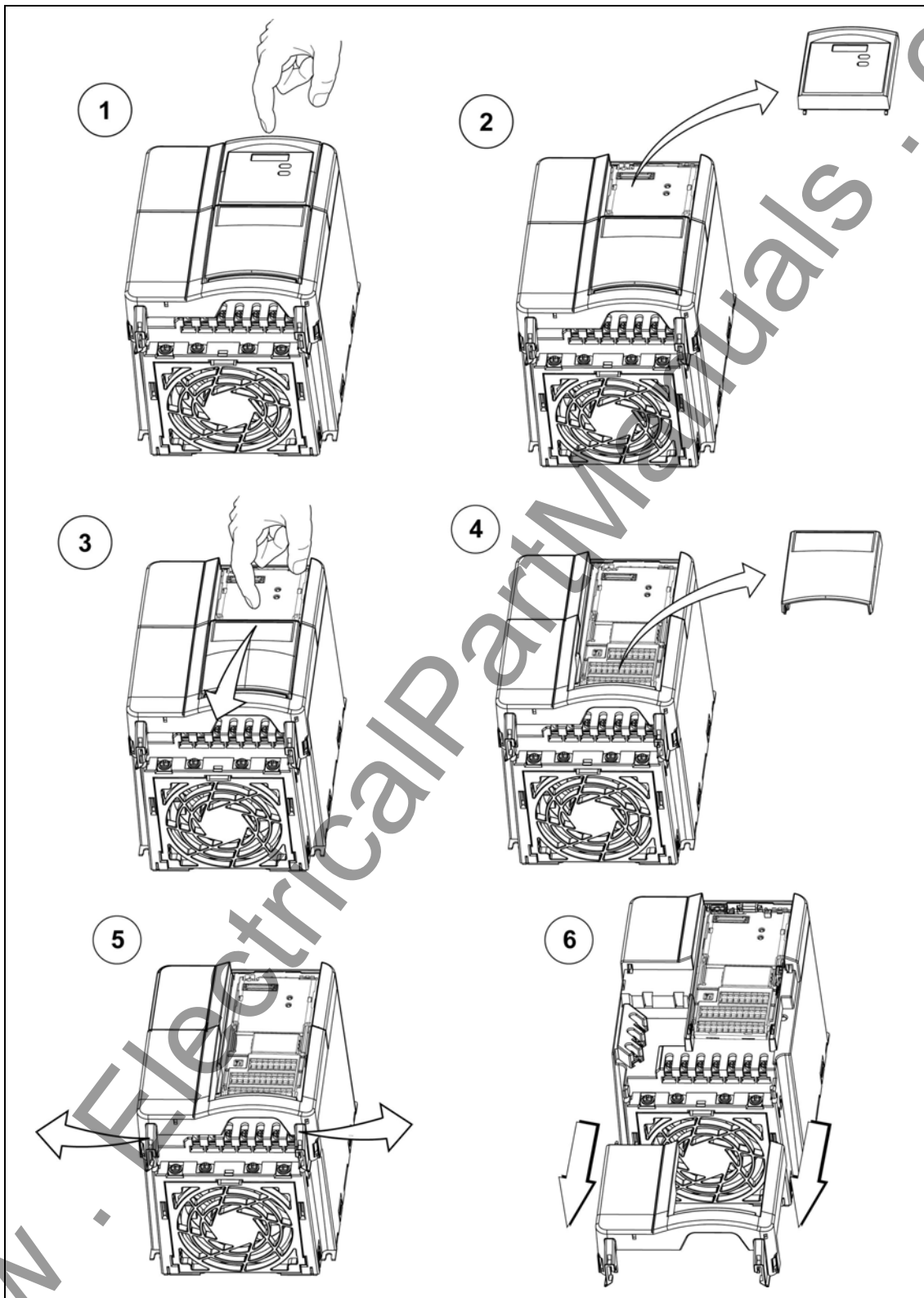


## B Removing Front Covers

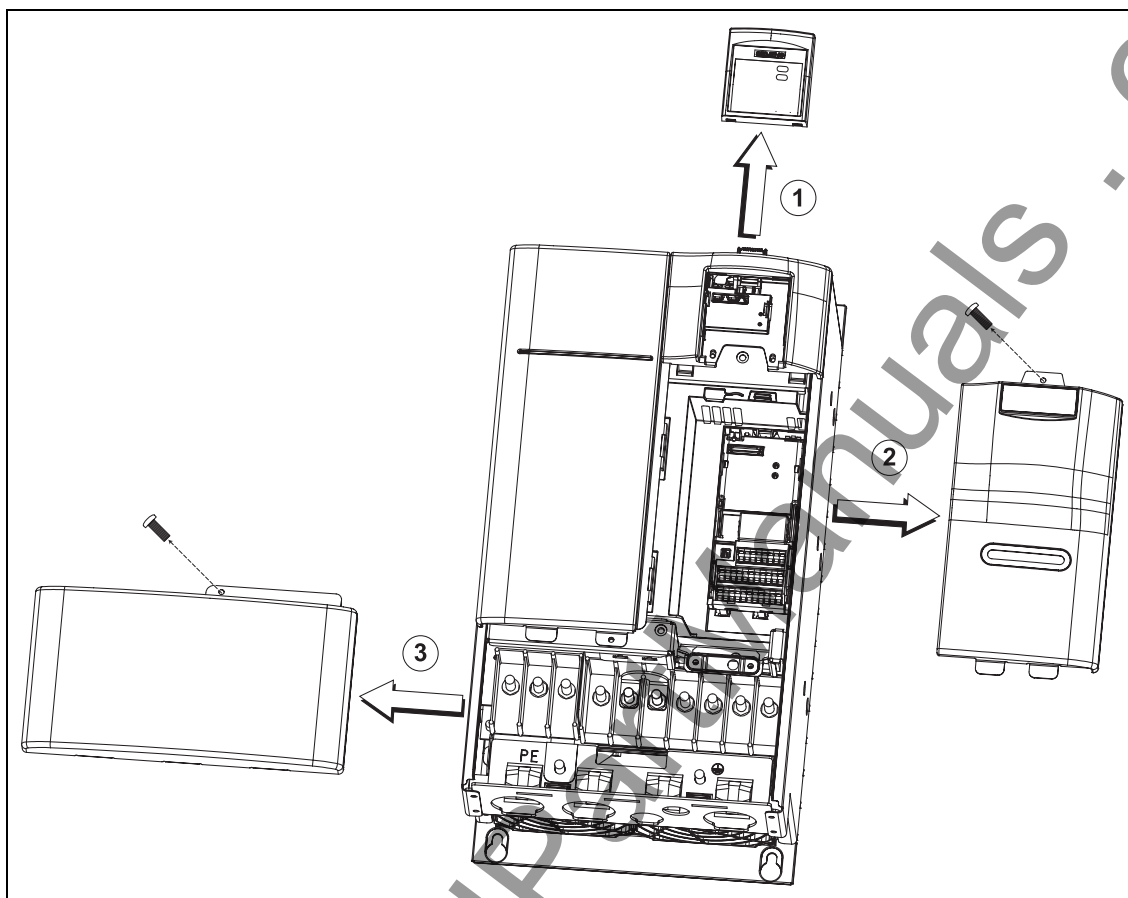
### B.1 Removing Front Covers. Frame Sizes A



### B.2 Removing Front Covers. Frame Sizes B and C

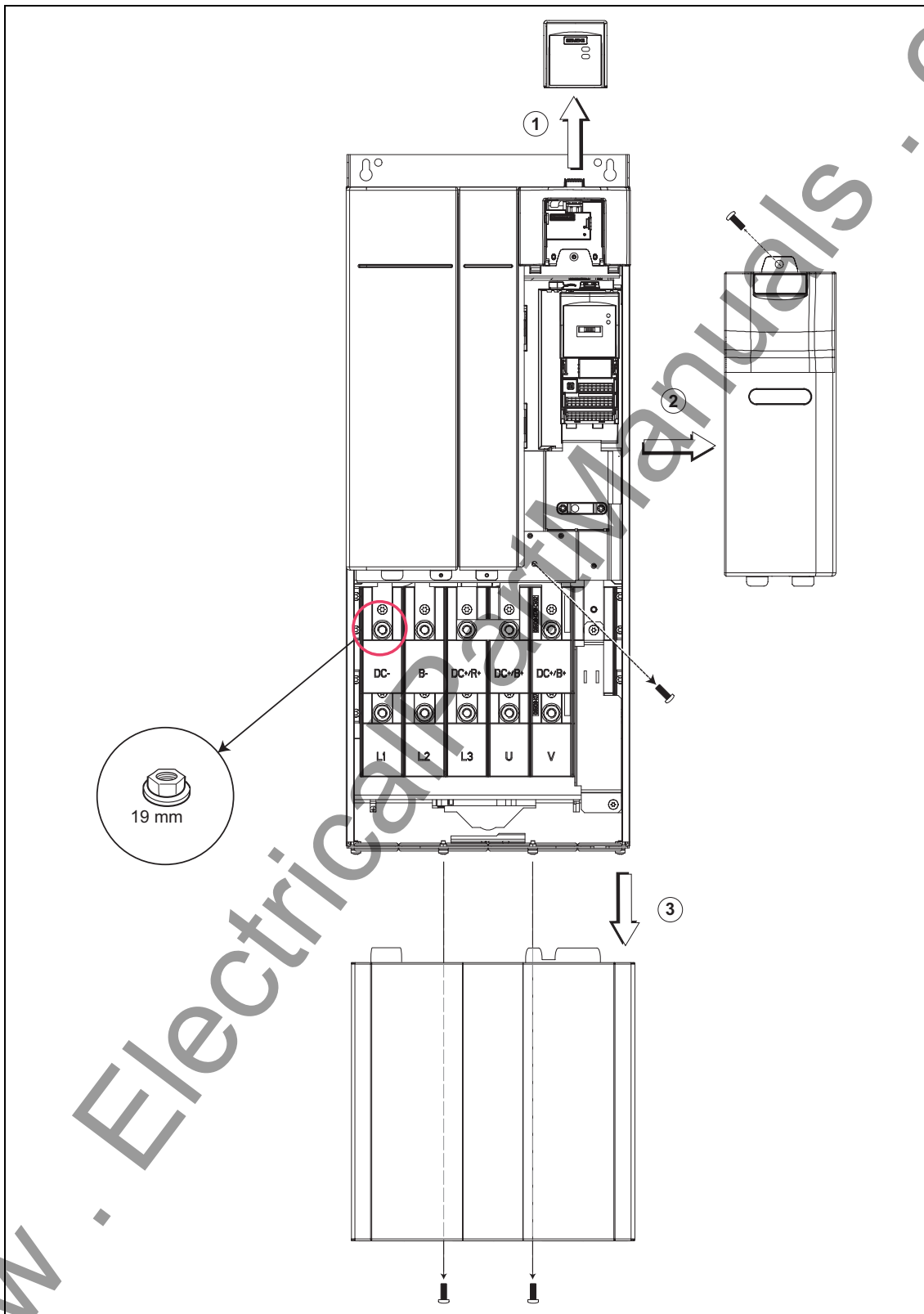


### B.3 Removing Front Covers. Frame Sizes D and E

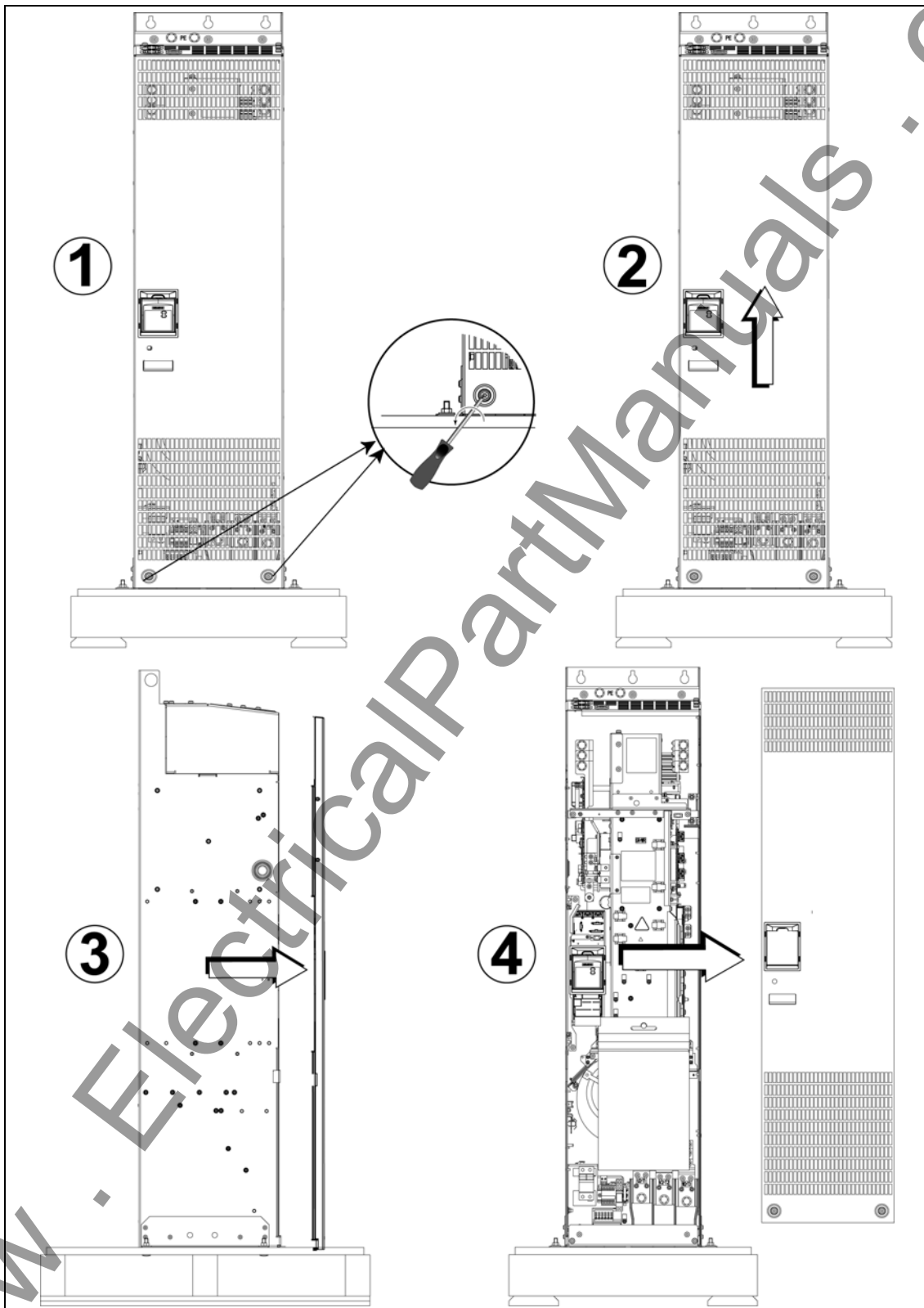


www.ElectricalParts.com

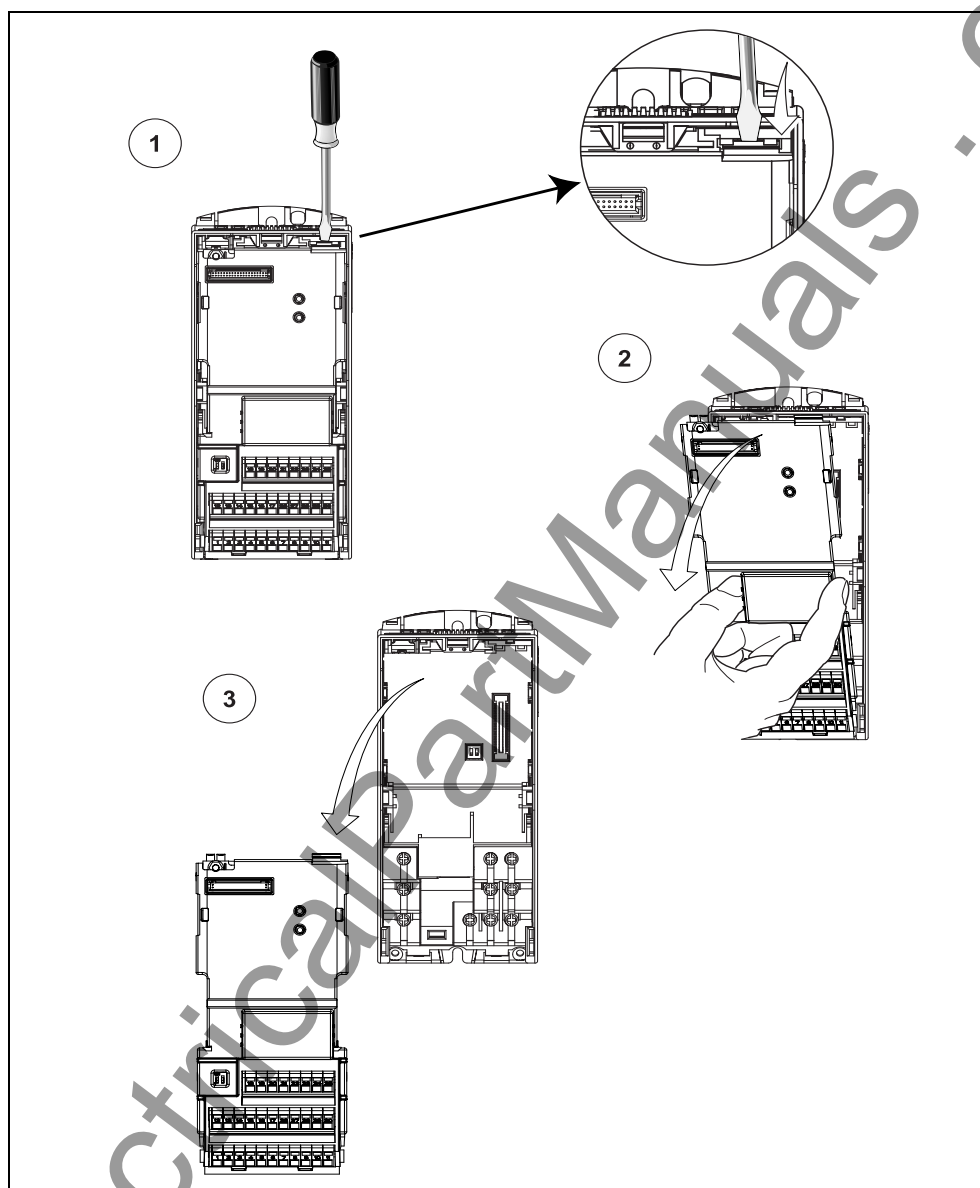
### B.4 Removing Front Covers. Frame Size F



### B.5 Removing Front Covers. Frame Sizes FX and GX



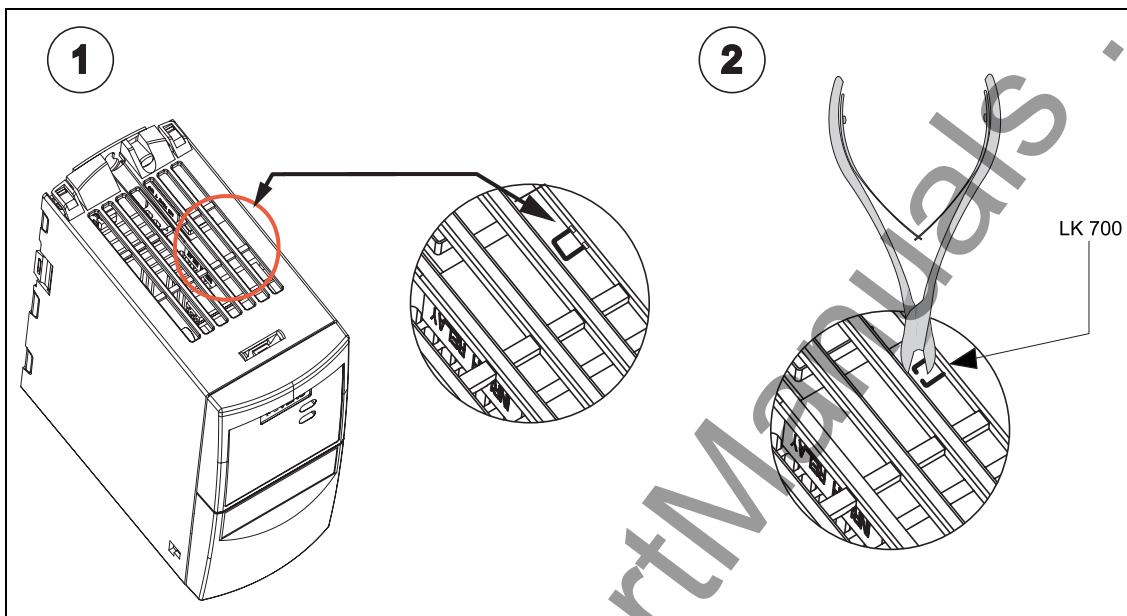
## C Removing the I/O Board

**NOTICE**

1. Only a small amount of pressure is required to release the I/O Board catch.
2. Currently, the I/O Board is removed using the same technique regardless of frame size.

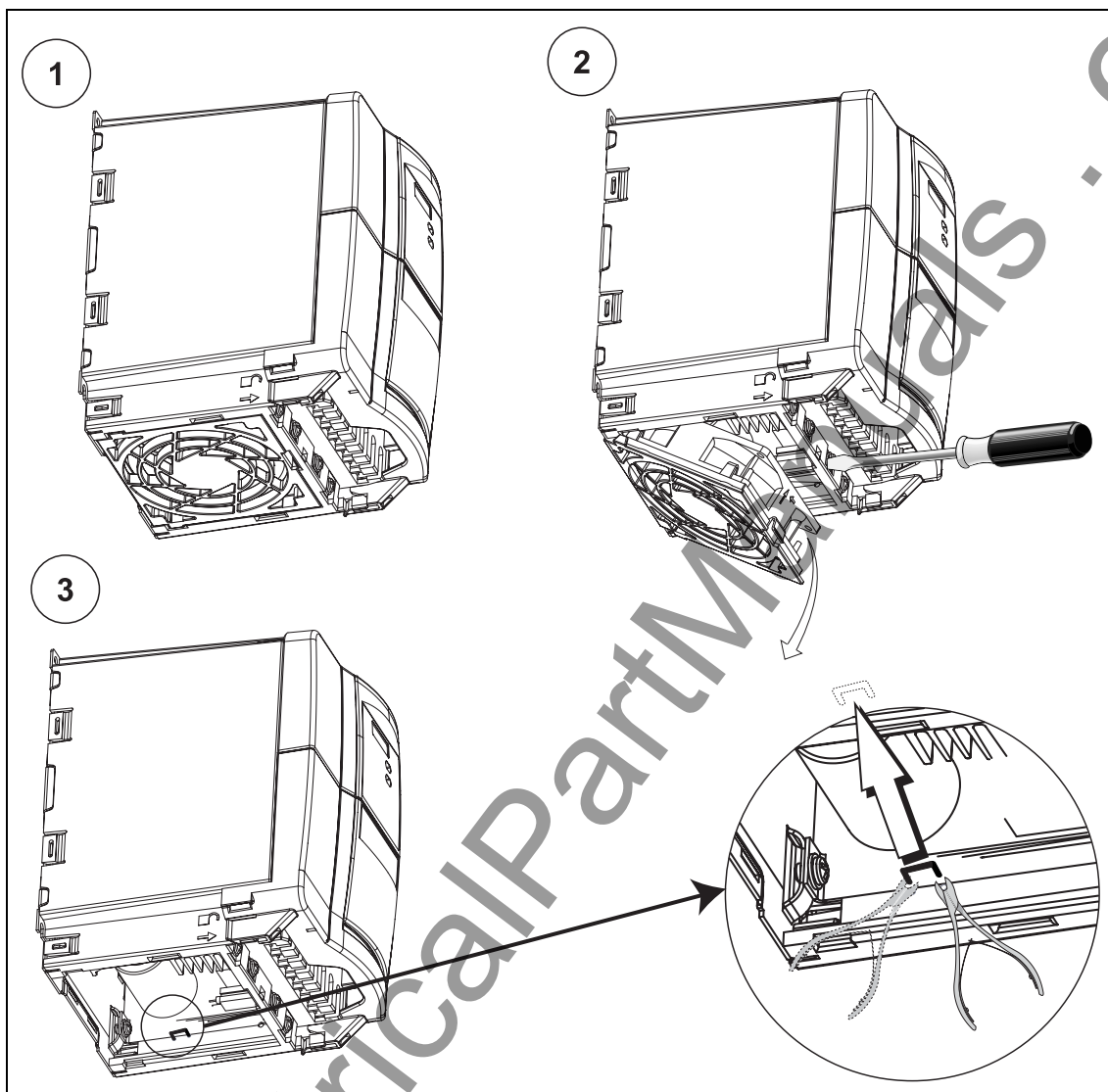
## D Removing 'Y' Cap

### D.1 Removing 'Y' Cap. Frame Size A



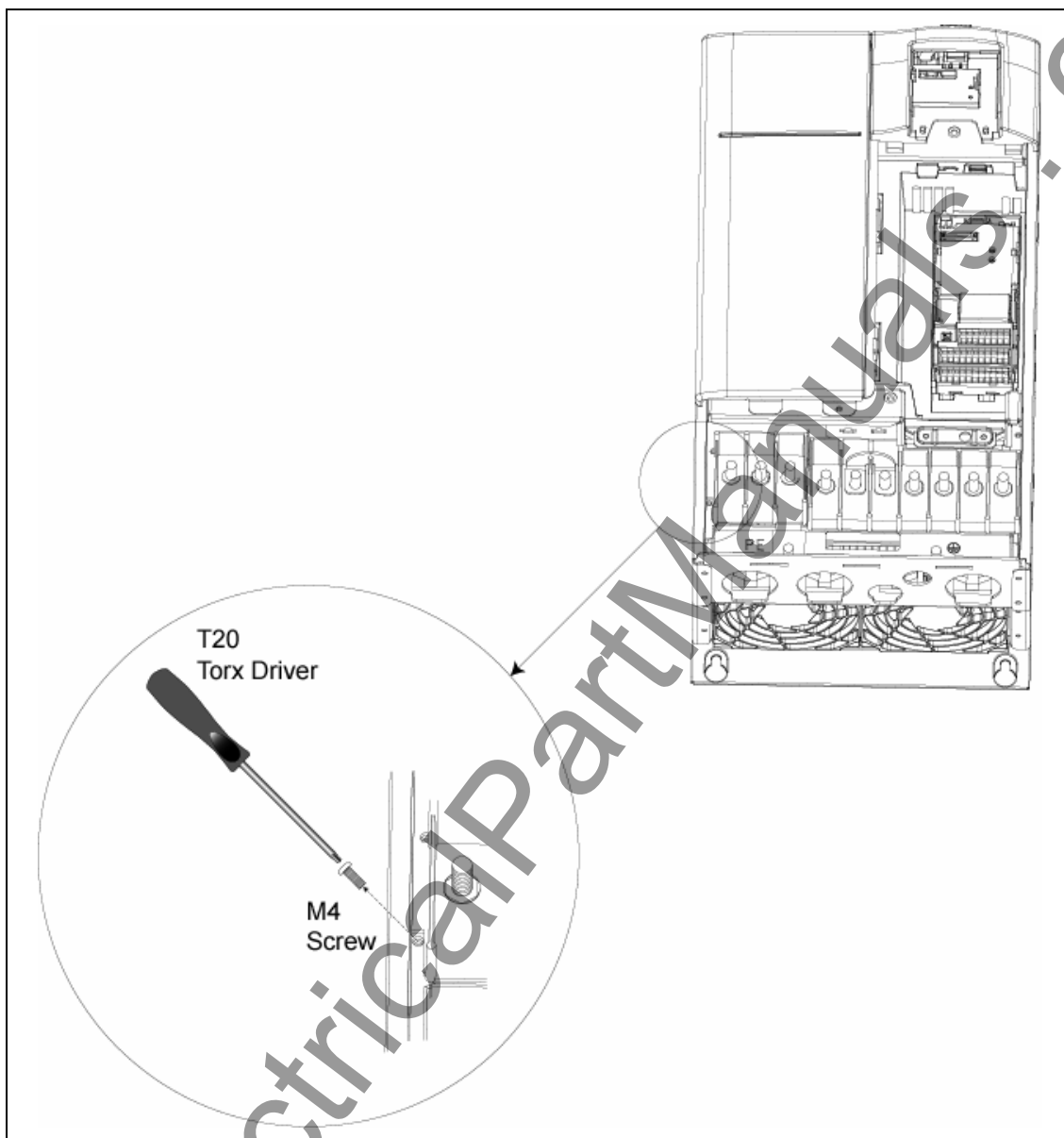
www.ElectricalPartMaterials.com

### D.2 Removing 'Y' Cap. Frame Sizes B and C

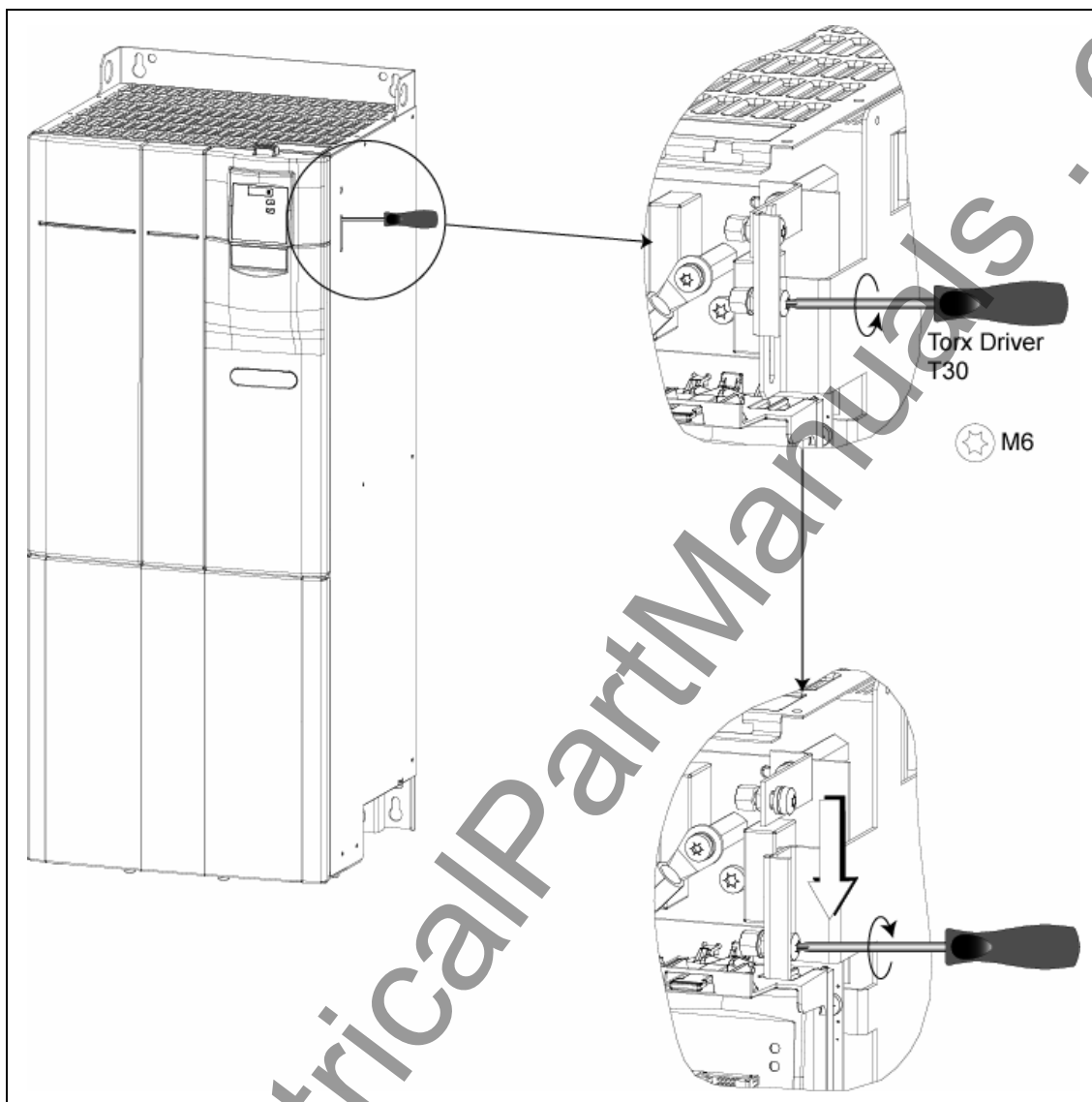


www.ElectricalPartMarts.com

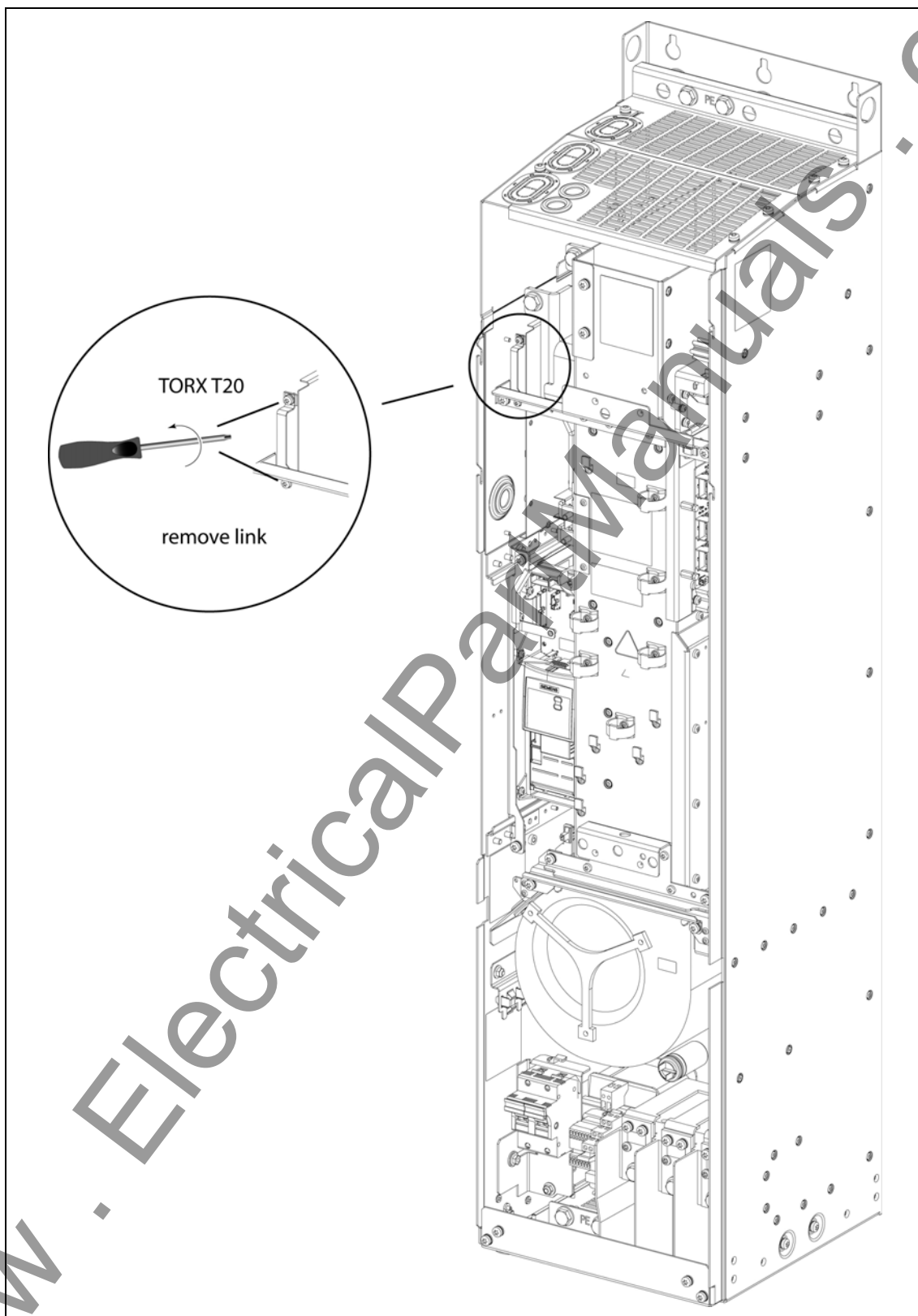
### D.3 Removing 'Y' Cap. Frame Sizes D and E



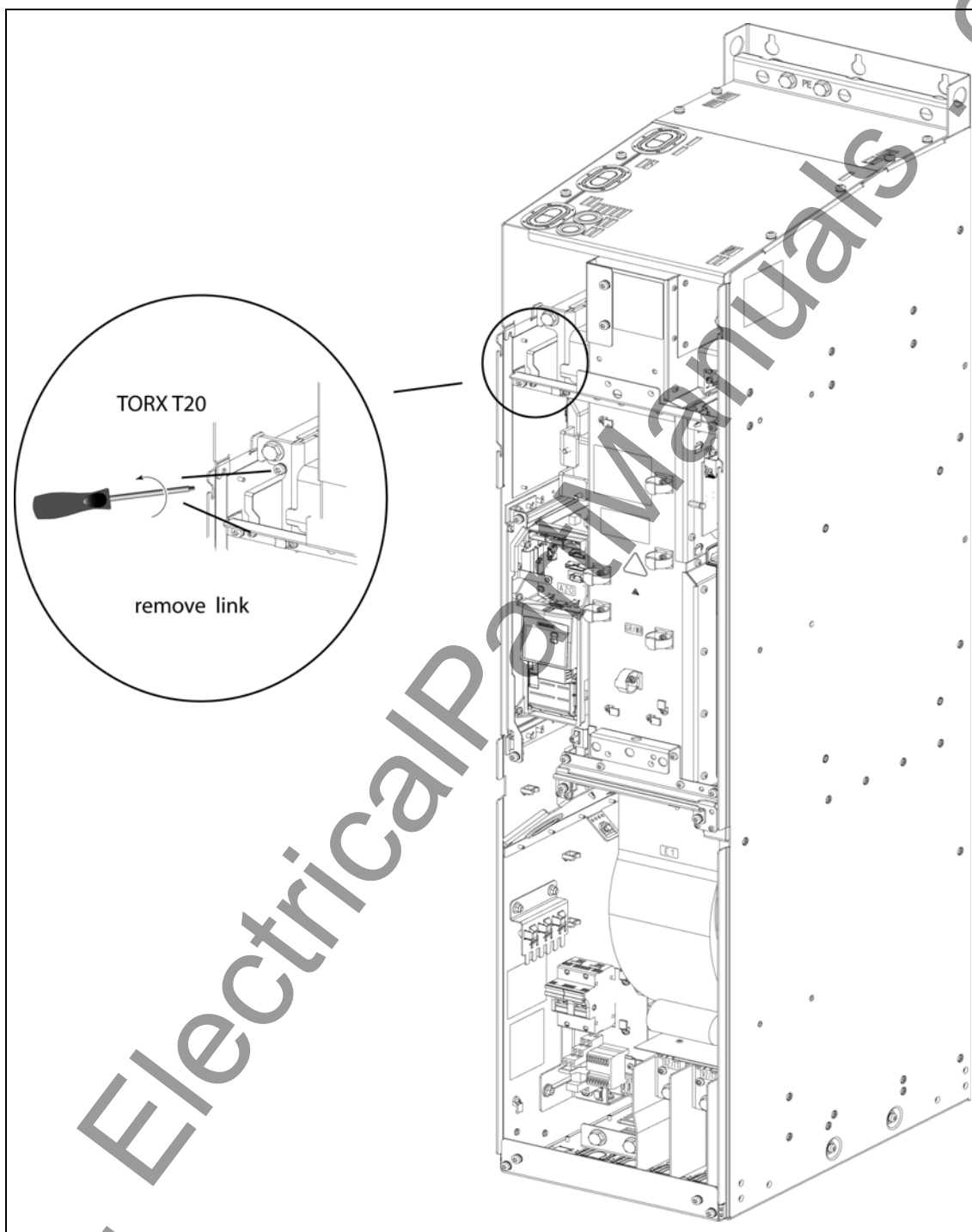
### D.4 Removing 'Y' Cap. Frame Size F



### D.5 Removing 'Y' Cap. Frame Size FX

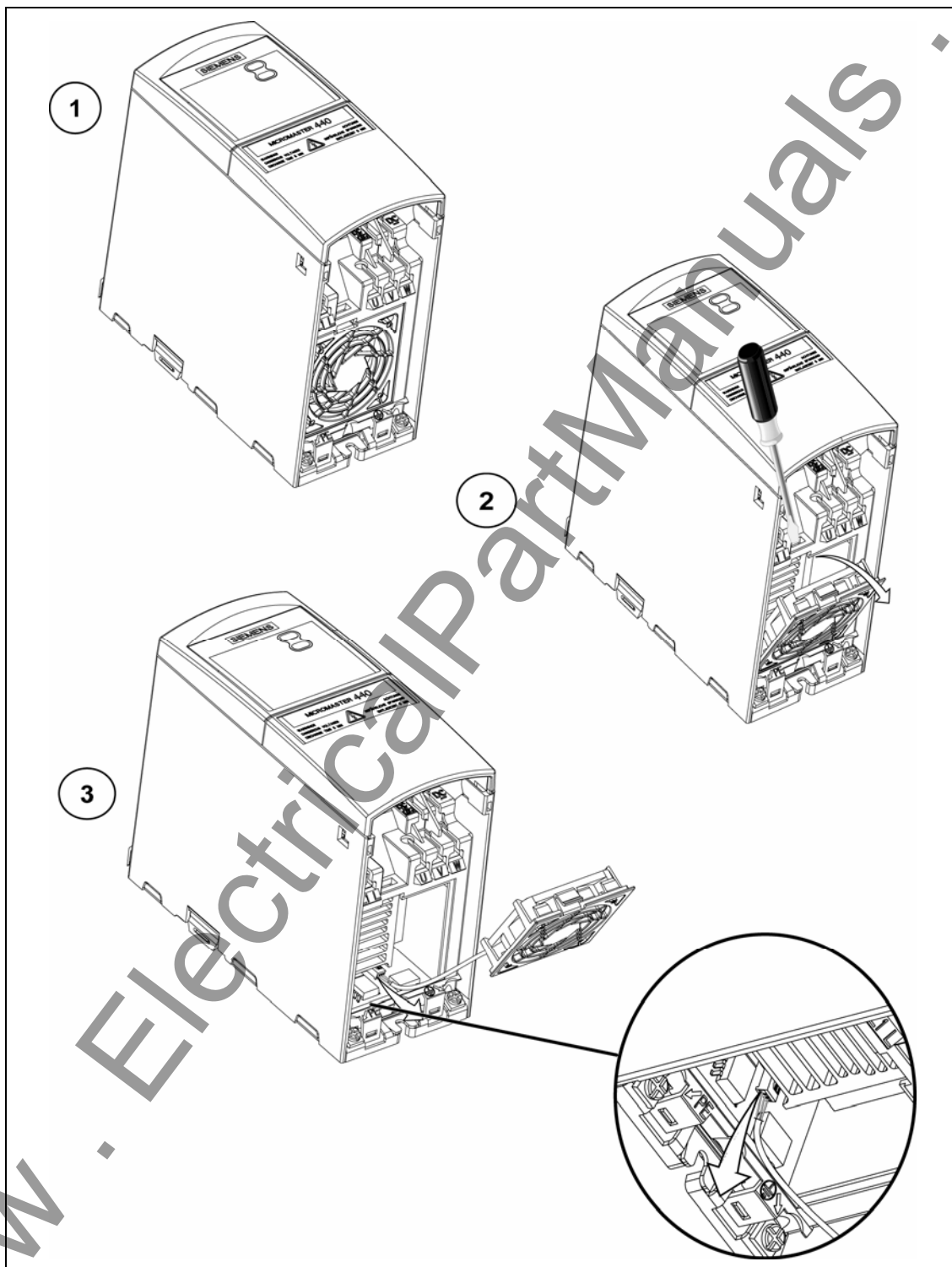


### D.6 Removing 'Y' Cap. Frame Size GX

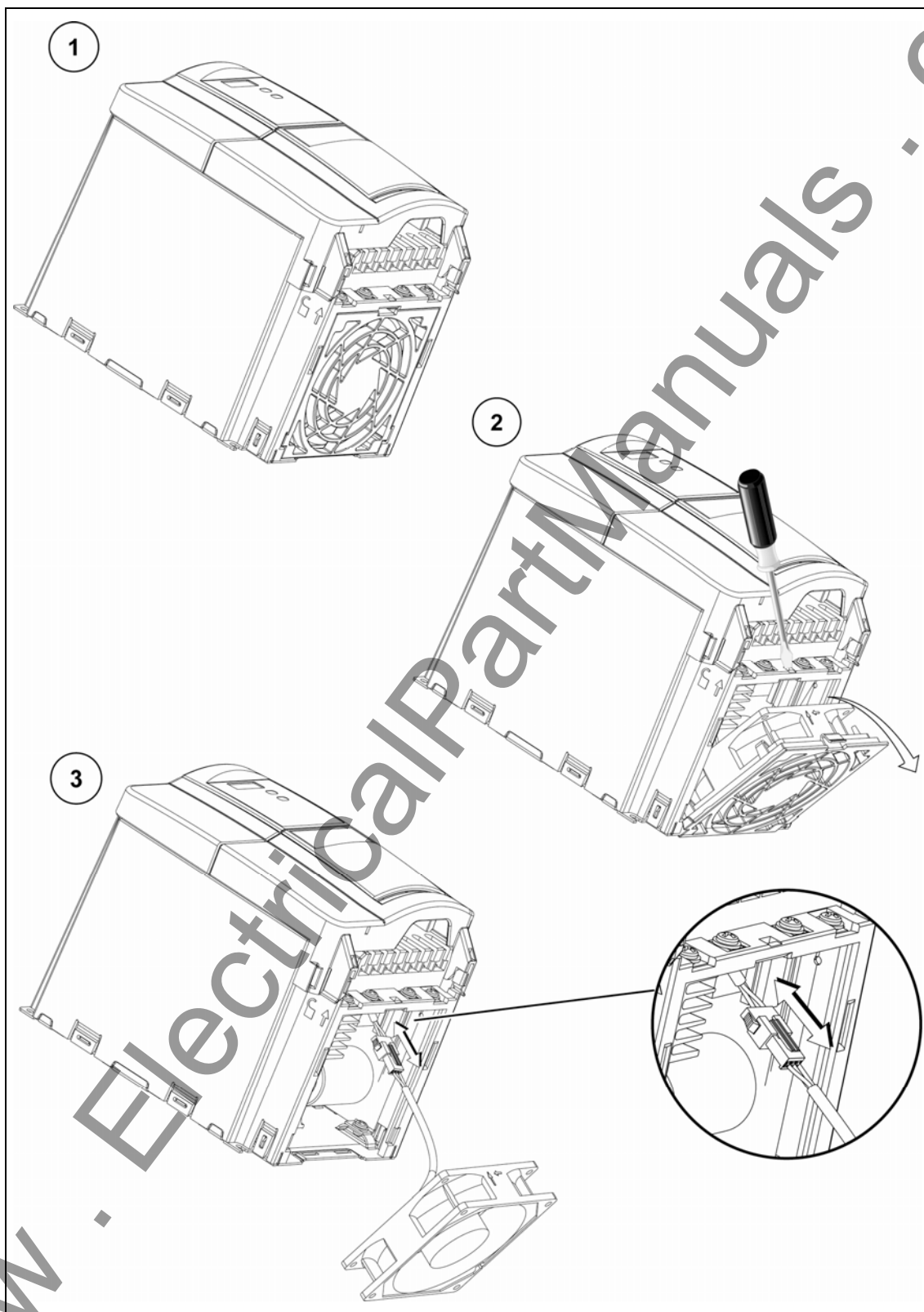


## E Removing fan

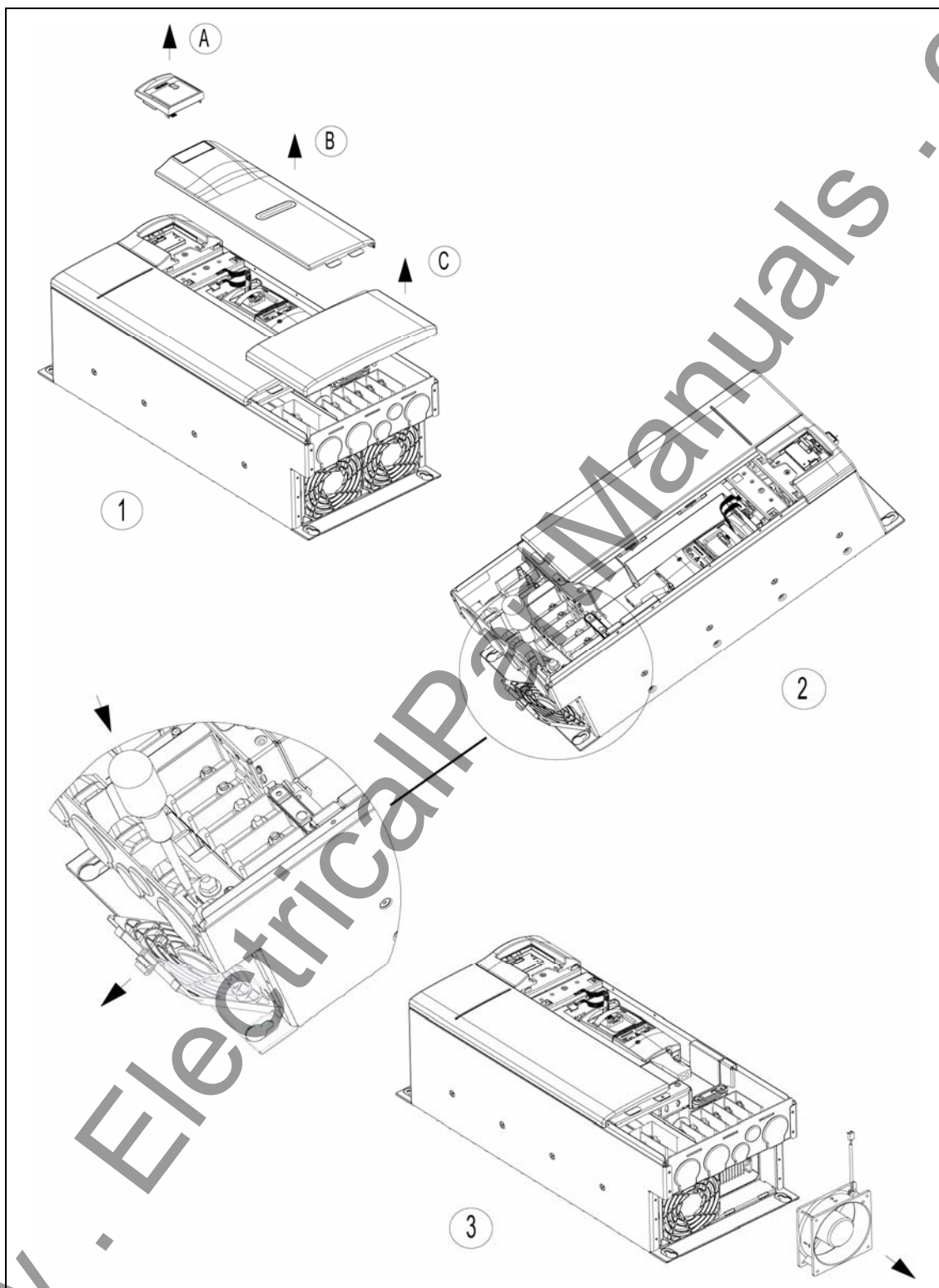
### E.1 Removing fan. Frame Size A



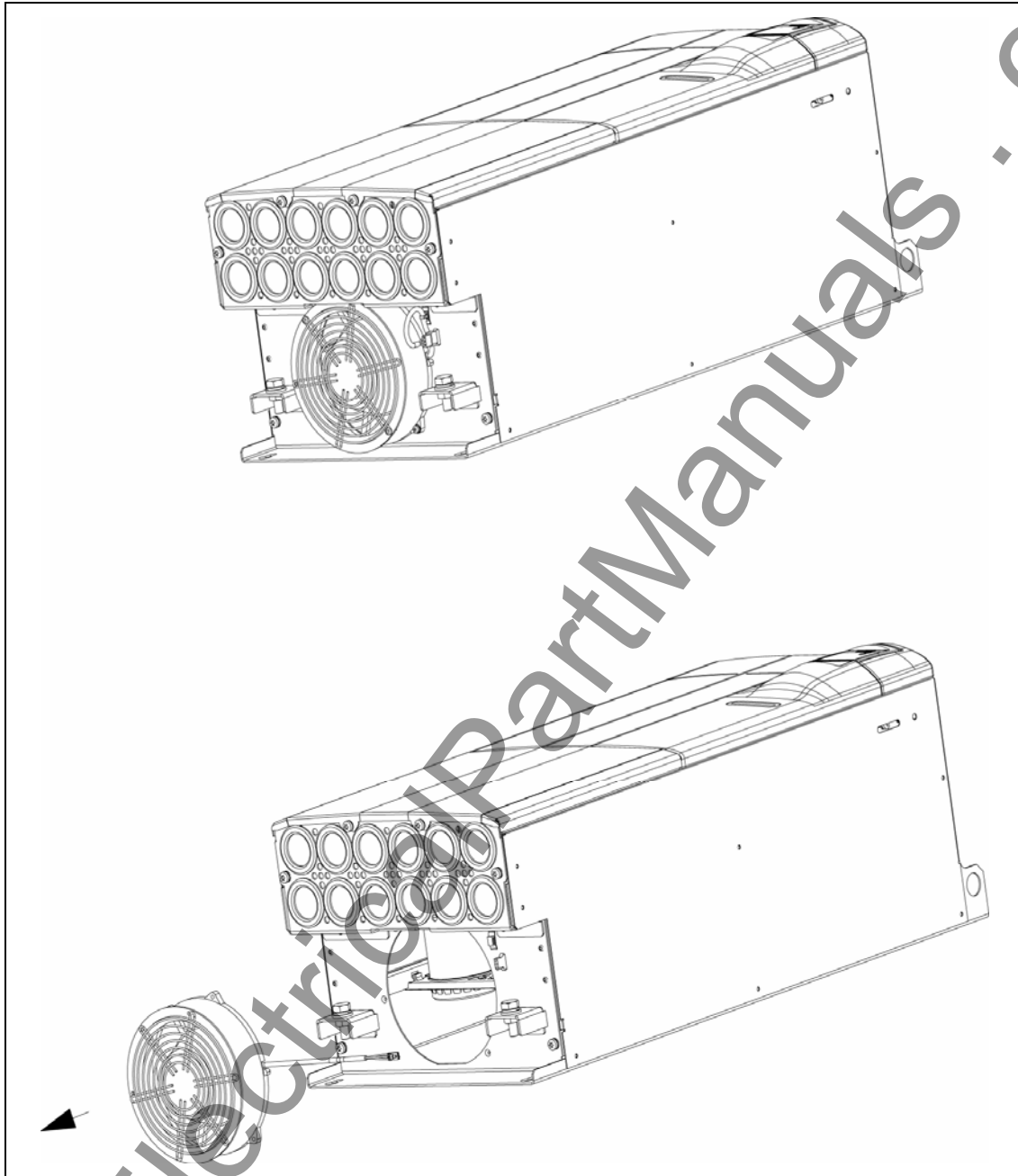
### E.2 Removing fan. Frame Sizes B and C



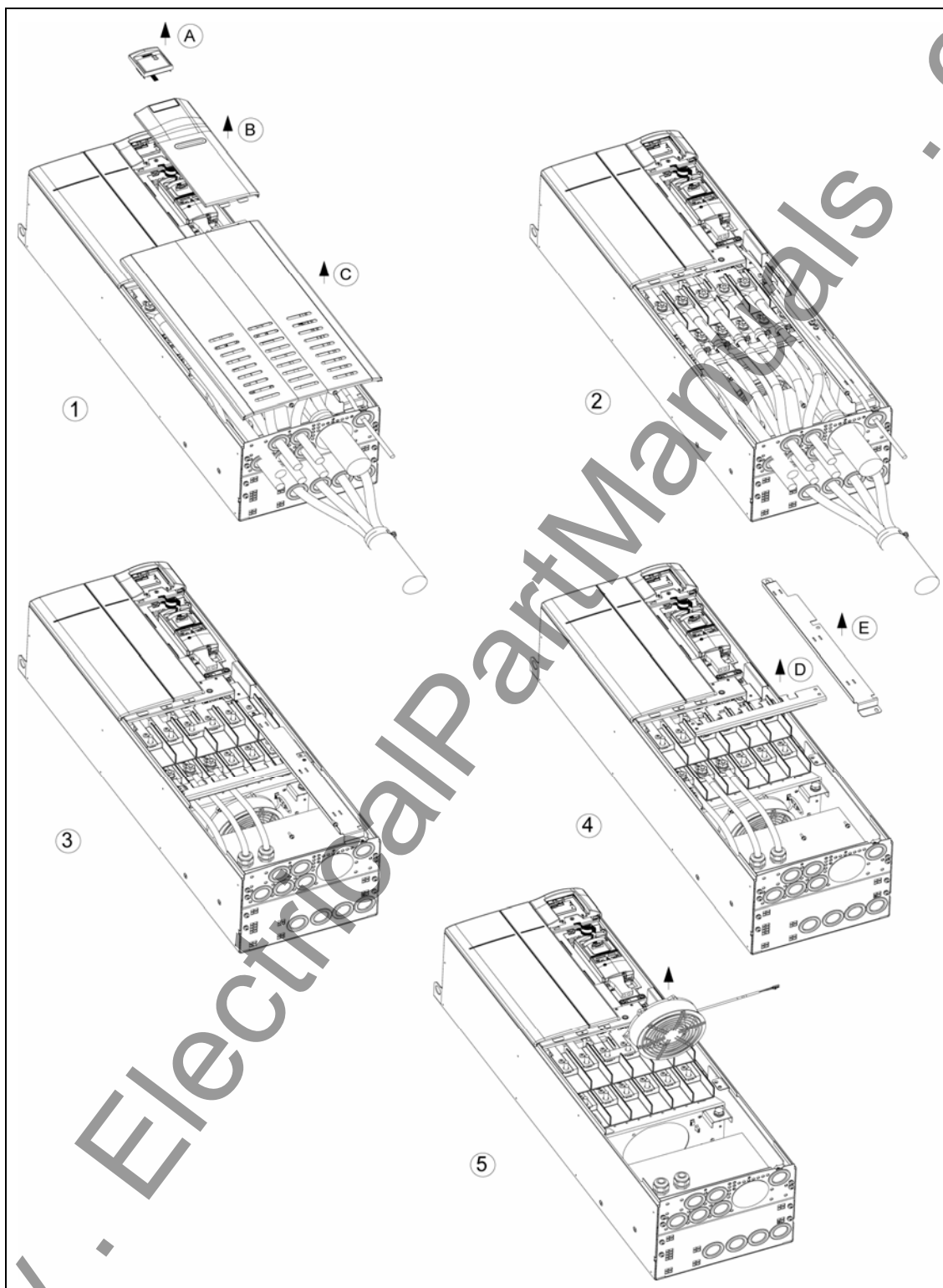
### E.3 Removing fan. Frame Size D and E



### E.4 Removing fan. Frame Size F



### E.5 Removing fan. Frame Size F with filter



## E.6 Removing fan. Frame Sizes FX and GX

When replacing the fans for sizes FX and GX, refer to the documentation CD ROM, directory - "Spares".

www.ElectricalPartManuals.com

## F Short circuit current rating (SCCR)

### Frame Sizes A to C

The equipment has a "standard SCCR" value of 10 kA, which complies with the requirements of UL508C.

In addition to the "standard SCCR" a "high SCCR" is available which can be used for industrial control panel installations in line with the National Electrical Code (NEC) article 409 (edition 2005) and Underwriters Laboratories UL508A (effective April 2006).

The uL certification of MICROMASTER 440 allows the drives to adopt a high SCCR equal to the interrupt current rating of the branch-circuit protection (BCP) device protecting the drive.

Hence by selection of the correct uL listed BCP device with appropriate interrupt rating for the application, any high SCCR rating can be achieved for MICROMASTER 440, including SCCR values above 10 kA.

The above statements are valid for the respective maximum voltage of the drive when protected by a UL recognised/listed H, J or K type fuse, a circuit breaker or self-protected combination motor controller.

### Frame Sizes D to GX

The equipment has a "standard SCCR" value of 42 kA, which complies with the requirements of UL508C.

A "high SCCR", which can be used for industrial control panel installations in line with the National Electrical Code (NEC) article 409 (edition 2005) and Underwriters Laboratories UL508A (effective April 2006), can be achieved with the use of current limiting fuses or circuit breakers with an appropriate interrupt rating and derived let through current.

For compliance with NEC article 409 and UL508A the calculation, selection and marking of the current limiting device must be carried out by a qualified engineer.

The above statements are valid for the respective maximum voltage of the drive when protected by a UL recognised/listed H, J or K type fuse, a circuit breaker or self-protected combination motor controller.

## G Standards



### European Low Voltage Directive

The MICROMASTER product range complies with the requirements of the Low Voltage Directive 73/23/EEC as amended by Directive 98/68/EEC. The units are certified for compliance with the following standards:

EN 61800-5-1 Adjustable speed electrical power drive systems,  
Part 5-1: Safety requirements –  
Electrical, thermal and energy

EN 60204-1 Safety of machinery - Electrical equipment of machines

### European Machinery Directive

The MICROMASTER inverter series does not fall under the scope of the Machinery Directive. However, the products have been fully evaluated for compliance with the essential Health & Safety requirements of the directive when used in a typical machine application. A Declaration of Incorporation is available on request.

### European EMC Directive

When installed according to the recommendations described in this manual, the MICROMASTER fulfils all requirements of the EMC Directive as defined by the EMC Product Standard for Power Drive Systems EN61800-3.



### Underwriters Laboratories

UL and CUL LISTED POWER CONVERSION EQUIPMENT

### ISO 9001

Siemens plc operates a quality management system, which complies with the requirements of ISO 9001.

## H List of Abbreviations

AC	Alternating current
AD	Analog digital converter
ADC	Analog digital converter
ADR	Address
AFM	Additional frequency modification
AG	Automation unit
AIN	Analog input
AOP	Advanced operator panel
AOUT	Analog output
ASP	Analog setpoint
ASVM	Asymmetric space vector modulation
BCC	Block check character
BCD	Binary-coded decimal code
BI	Binector input
BICO	Binector / connector
BO	Binector output
BOP	Basic operator panel
C	Commissioning
CB	Communication board
CCW	Counter-clockwise
CDS	Command data set
CI	Connector input
CFM	Cubicfeet per minute (1 l/s $\cong$ 2,1 CFM)
CM	Configuration management
CMD	Commando
CMM	Combimaster
CO	Connector output
CO/BO	Connector output / Binector output
COM	Common (terminal that is connected to NO or NC)
COM-Link	Communication link
CT	Commissioning. ready to run
CT	Constant torque
CUT	Commissioning. run. ready to run
CW	Clockwise
DA	Digital analog converter
DAC	Digital analog converter
DC	Direct current
DDS	Drive data set
DIN	Digital input
DIP	DIP switch
DOUT	Digital output

DS	Drive state
EEC	European Economic Community
EEPROM	Electrical erasable programmable read-only memory
ELCB	Earth leakage circuit breaker
EMC	Electro-magnetic compatibility
EMF	Electromotive force
EMI	Electro-magnetic interference
ESB	Equivalent circuit
FAQ	Frequently asked questions
FB	Function block
FCC	Flux current control
FCL	Fast current limit
FF	Fixed frequency
FFB	Free function block
FOC	Field orientated control
FSA	Frame size A
GSG	Getting started guide
GUI ID	Global unique identifier
HIW	Main actual value
HSW	Main setpoint
HTL	High-threshold logic
I/O	Input and output
IBN	Commissioning
IGBT	Insulated gate bipolar transistor
IND	Sub-index
JOG	Jog
KIB	Kinetic buffering
LCD	Liquid crystal display
LED	Light emitting diode
LGE	Length
MHB	Motor holding brake
MM4	MICROMASTER 4th. Generation
MOP	Motor potentiometer
NC	Normally closed
NO	Normally open
OPI	Operating instructions
PDS	Power drive system
PID	PID controller (proportional. integral. derivative)
PKE	Parameter ID
PKW	Parameter ID value
PLC	Programmable logic controller
PLI	Parameter list
PPO	Parameter process data object
PTC	Positive temperature coefficient

PWE	Parameter value
PWM	Pulse-width modulation
PX	Power extension
PZD	Process data
QC	Quick commissioning
RAM	Random-access memory
RCCB	Residual current circuit breaker
RCD	Residual current device
RFG	Ramp function generator
RFI	Radio-frequency interference
RPM	Revolutions per minute
SCL	Scaling
SDP	Status display panel
SLVC	Sensorless vector control
STW	Control word
STX	Start of text
SVM	Space vector modulation
TTL	Transistor-transistor logic
USS	Universal serial interface
VC	Vector control
VT	Variable torque
ZSW	Status word
ZUSW	Additional setpoint

## Index

### A

Adaptation of fan voltage.....	41
Alarm Messages.....	260
Altitude.....	24
Ambient operating conditions	
Altitude.....	24
Atmospheric Pollution.....	25
Electromagnetic Radiation.....	24
Humidity Range.....	24
Installation and cooling.....	25
Shock.....	24
Temperature.....	24
Vibration.....	24
Water hazard.....	25
Ambient operating conditions.....	24
Atmospheric pollution.....	25
Automatic restart.....	211

### B

BICO technology.....	57
Block diagram.....	74
Brake unit.....	36

### C

Changing the Operator Panel.....	281
Changing the Operator Panel.....	281
Closed-loop motor control.....	235
Closed-loop speed control.....	248
Closed-loop torque control.....	253
V/f control.....	235
Vector control.....	243
Closed-loop speed control.....	248
Closed-loop torque control.....	253
Closed-loop Vdc control.....	215
Kinetic buffering.....	218
Vdc_max controller.....	215
Commissioning.....	77
50 / 60 Hz setting.....	79
Commissioning the application.....	97
Fast commissioning.....	83
Motor / control data.....	88
Motor data identification.....	91
Reset to the factory setting.....	133
Series commissioning.....	132
With BOP or AOP.....	83

Communications.....	144
Compound braking.....	205
Connection drawing	
FX.....	38
GX.....	39
Connection of brake unit.....	36
Connection Terminals.....	37
Contact address.....	5
Current reduction depending on pulse frequency.....	265

### D

Data sets.....	63
DC braking.....	202
Dimensions and Torques.....	30
Drill pattern for MICROMASTER 440.....	27
Dynamic braking.....	206

### E

Electrical Installation.....	33
Electro-Magnetic Compatibility	
EC type-examination certificate.....	276
general.....	275, 276
self-certification.....	276
technical construction file.....	276
Electro-Magnetic Interference.....	43
avoiding EMI.....	43
Electromagnetic radiation.....	24
Electronic brakes.....	202
Compound braking.....	205
DC braking.....	202
Dynamic braking.....	206
EMC.....	276
EMC Directive Compliance.....	277
EMC performance	
filtered for residential, commercial and light industry.....	279
filtered industrial class.....	278
general industrial class.....	278
EMI.....	43

<b>F</b>	
Fan fuses .....	41
Fault messages .....	260
with the BOP fitted .....	259
with the SDP fitted .....	258
Features .....	19
Fixed frequencies .....	167
Flying restart.....	213
Foreword .....	5
Free function blocks .....	191
Functions .....	47
<b>H</b>	
Humidity Range .....	24
<b>I</b>	
Inputs / outputs .....	135
Analog inputs .....	140
Analog outputs .....	142
Digital inputs .....	135
Digital outputs .....	138
Installation .....	21
after a period of storage.....	21, 23
Installation and cooling.....	25
Installation dimensions for MICROMASTER 440 Version FX .....	28
Installation dimensions for MICROMASTER 440 Version GX.....	29
Installation of options.....	32
<b>J</b>	
Jog.....	172
JOG .....	172
<b>L</b>	
Load torque monitoring .....	223
Long cables operation with.....	35
<b>M</b>	
Main characteristics.....	19
Mechanical Installation .....	26
MICROMASTER 440 general .....	18
main characteristics.....	19
performance characteristics.....	20
protection characteristics .....	20
specifications .....	261
Monitoring functions / messages.....	221
Motor connections .....	35
Motor holding brake .....	196
Motorized potentiometer .....	170
Mounting on standard rail .....	31
Mounting onto standard rail .....	31
<b>O</b>	
Online Service & Support .....	5
Operation with long cables .....	35
Residual Current Device .....	34
ungrounded IT supplies.....	34
Operator panels for MM4.....	70
AOP .....	71
BOP .....	70
SDP .....	75
Options Inverter-dependent options .....	274
Inverter-independent options .....	273
Options.....	273
Options for electronic box .....	32
Overload responses.....	227
Overview .....	17
<b>P</b>	
Parameters .....	51
Attributes .....	52
Changing with BOP .....	73
Grouping and access .....	56
Monitoring parameters .....	52
Setting parameters .....	51
Performance characteristics .....	20
Performance Ratings .....	262
PID controller .....	173
PID dancer roll control.....	179
PID fixed setpoint .....	178
PID motorized potentiometer .....	177
Positioning down ramp .....	219
Power and motor connections .....	35
Access .....	36
single phase .....	40
Power connections.....	35
Power module protection .....	232
Protection characteristics.....	20
<b>Q</b>	
Qualified personnel.....	6

<b>R</b>		<b>T</b>	
Removing 'Y' Cap.....	288	Technical Support.....	5
Removing fan		Technological controller.....	173
Frame Size A.....	294	Terminal Torques.....	264
Frame Size D and E.....	296	Thermal motor protection.....	227
Frame Size F.....	297	Troubleshooting.....	257
Frame Size F with filter.....	298	<b>U</b>	
Frame Sizes B and C.....	295	Ungrounded (IT) supplies	
Frame Sizes FX and GX.....	299	operation with.....	34
Removing Front Covers.....	282	<b>V</b>	
Removing the I/O Board.....	287	V/f control.....	235
Residual Current Device		Vector control.....	243
operation with.....	34	<b>W</b>	
<b>S</b>		Warnings, cautions & notes	
Safety instructions.....	7	commissioning.....	8
Screening Methods.....	44	definitions.....	6
Setpoint channel.....	181	dismantling & disposal.....	9
AFM.....	181	general.....	7
Ramp-function generator.....	183	operation.....	9
Shock.....	24	repair.....	9
Specifications.....	266	transport & storage.....	8
Standards		Water hazard.....	25
European EMC Directive.....	301	Wiring Guidelines EMI.....	44
European Low Voltage Directive.....	301		
European Machinery Directive.....	301		
ISO 9001.....	301		
Underwriters Laboratories.....	301		

[www.ElectricalPartManuals.com](http://www.ElectricalPartManuals.com)

**Suggestions and/or Corrections**

<p><b>To:</b>          Siemens AG          Automation &amp; Drives Group          SD SM          P.O. Box 3269           D-91050 Erlangen          Federal Republic of Germany           Email:  <a href="mailto:documentation.sd@siemens.com">documentation.sd@siemens.com</a></p>	<p><b>Suggestions</b></p> <hr/> <p><b>Corrections</b></p> <p>For Publication/Manual:          MICROMASTER 440</p> <hr/> <p>User Documentation</p>
<p><b>From</b></p> <p>Name: _____</p> <p>Company/Service Department _____</p> <p>Address: _____          _____          _____</p> <p>Telephone: _____ / _____</p> <p>Telefax: _____ / _____</p>	<p>Operating Instructions</p> <p>Order Number:          6SE6400-5AW00-0BP0</p> <p>Date of Issue: 10/06</p> <hr/> <p>Should you come across any printing errors when reading this publication, please notify us on this sheet.</p> <p>Suggestions for improvement are also welcome.</p>

[www.ElectricalPartManuals.com](http://www.ElectricalPartManuals.com)

[www.ElectricalPartManuals.com](http://www.ElectricalPartManuals.com)

www.ElectricalPartManuals.com

Siemens AG  
Bereich Automation and Drives (A&D)  
Geschäftsgebiet Standard Drives (SD)  
Postfach 3269, D-91050 Erlangen  
Federal Republic of Germany

© Siemens AG 2001, 2002, 2003, 2005, 2006  
Subject to change without prior notice

Siemens Aktiengesellschaft

Order No.: 6SE6400-5AW00-0BP0  
Date: 10/06

