

# SIEMENS

## MICROMASTER 420

Parameter List

Issue 10/06



## Available Documentation for the MICROMASTER 420

### Getting Started Guide

Is for quick commissioning with SDP and BOP.



### Operating Instructions

Gives information about features of the MICROMASTER 420, Installation, Commissioning, Control modes, System Parameter structure, Troubleshooting, Specifications and available options of the MICROMASTER 420.



### Parameter List

The Parameter List contains the description of all Parameters structured in functional order and a detailed description. The Parameter list also includes a series of function plans.



### Catalogues

In the catalogue you will find all needs to select a certain inverter, as well as filters chokes, operator panels or communications options.



# SIEMENS

## MICROMASTER 420

**Parameter List**  
User Documentation

**Valid for**

*Inverter Type*  
MICROMASTER 420

Issue 10/06

*Software Version*  
V1.2

**Issue 10/06**

**Block Diagram and  
Terminals**

**Parameter List**

**Function Diagrams**

**Faults and Alarms**

**Abbreviations**

www.ElectricalPartManuals.com

**Warning**

Please refer to all Definitions and Warnings contained in the Operating Instructions. You will find the Operating Instructions on the Docu CD delivered with your inverter. If the CD is lost, it can be ordered via your local Siemens department under the Order No. 6SE6400-5AB00-1AP0.

Information about MICROMASTER 420 is also available from:

**Regional Contacts**

Please get in touch with your contact for Technical Support in your Region for questions about services, prices and conditions of Technical Support.

**Central Technical Support**

The competent consulting service for technical issues with a broad range of requirements-based services around our products and systems.

**Europe / Africa**

Tel: +49 (0) 180 5050 222

Fax: +49 (0) 180 5050 223

Email: [adsupport@siemens.com](mailto:adsupport@siemens.com)

**America**

Tel: +1 423 262 2522

Fax: +1 423 262 2589

Email: [simatic.hotline@sea.siemens.com](mailto:simatic.hotline@sea.siemens.com)

**Asia / Pacific**

Tel: +86 1064 757 575

Fax: +86 1064 747 474

Email: [adsupport.asia@siemens.com](mailto:adsupport.asia@siemens.com)

**Online Service & Support**

The comprehensive, generally available information system over the Internet, from product support to service & support to the support tools in the shop.

<http://www.siemens.com/automation/service&support>

**Internet Address**

Customers can access technical and general information under the following address:

<http://www.siemens.com/micromaster>

Approved Siemens Quality for Software and Training is to DIN ISO 9001, Reg. No. 2160-01

The reproduction, transmission or use of this document, or its contents is not permitted unless authorized in writing. Offenders will be liable for damages. All rights including rights created by patent grant or registration of a utility model or design are reserved.

© Siemens AG 2001, 2002, 2004. All Rights Reserved.

MICROMASTER® is a registered trademark of Siemens

Other functions not described in this document may be available. However, this fact shall not constitute an obligation to supply such functions with a new control, or when servicing.

We have checked that the contents of this document correspond to the hardware and software described. There may be discrepancies nevertheless, and no guarantee can be given that they are completely identical. The information contained in this document is reviewed regularly and any necessary changes will be included in the next edition. We welcome suggestions for improvement.

Siemens handbooks are printed on chlorine-free paper that has been produced from managed sustainable forests. No solvents have been used in the printing or binding process.

Document subject to change without prior notice.

# Parameters MICROMASTER 420

This Parameter List must only be used together with the Operating Instructions of the MICROMASTER 420. Please pay special attention to the Warnings, Cautions, Notices and Notes contained in these manuals.

## Table of Contents

1	Block Diagram and Terminals .....	7
1.1	Block Diagram .....	7
1.2	Power Terminals .....	8
1.3	Control Terminals .....	8
2	Parameters .....	9
2.1	Introduction to MICROMASTER System Parameters .....	9
2.2	Quick commissioning (P0010 = 1) .....	12
2.3	Binector Input Parameters .....	14
2.4	Connector Input Parameters .....	14
2.5	Binector Output Parameters .....	14
2.6	Connector Output Parameters .....	15
2.7	Connector/Binector Output Parameters .....	15
3	Parameter Description .....	16
3.1	Common parameters .....	16
3.2	Diagnosis parameters .....	20
3.3	Inverter parameters (HW) .....	28
3.4	Motor parameters .....	33
3.5	Command source .....	44
3.6	Digital inputs .....	46
3.7	Digital outputs .....	51
3.8	Analog inputs .....	53
3.9	Analog outputs .....	58
3.10	BICO command parameters .....	61
3.11	Communication parameters .....	65
3.12	Setpoint source .....	70
3.13	Fixed frequencies .....	72
3.14	Motorized potentiometer (MOP) .....	75
3.15	JOG .....	77
3.16	Setpoint channel .....	79
3.17	Ramp-function generator .....	84
3.18	Flying restart .....	88
3.19	Automatic restart .....	90
3.20	Motor holding brake .....	92
3.21	DC braking .....	94

3.22	Compound braking .....	96
3.23	Vdc controller .....	97
3.24	Control mode .....	99
3.25	V/f control parameters .....	100
3.25.1	Slip compensation .....	105
3.25.2	Resonance damping .....	106
3.25.3	I <sub>max</sub> controller .....	107
3.25.4	Soft starting .....	108
3.26	Inverter parameters (Modulator) .....	109
3.27	Motor data identification .....	110
3.28	Reference parameters .....	111
3.29	Communication parameters (USS, CB) .....	113
3.30	Faults, Alarms, Monitoring .....	125
3.31	Technology controller (PID controller) .....	132
3.32	Inverter parameters .....	143
4	Function Diagrams .....	145
5	Faults and Alarms .....	179
5.1	Fault messages .....	179
5.2	Alarm Messages .....	184
6	Abbreviations .....	189

# 1 Block Diagram and Terminals

## 1.1 Block Diagram

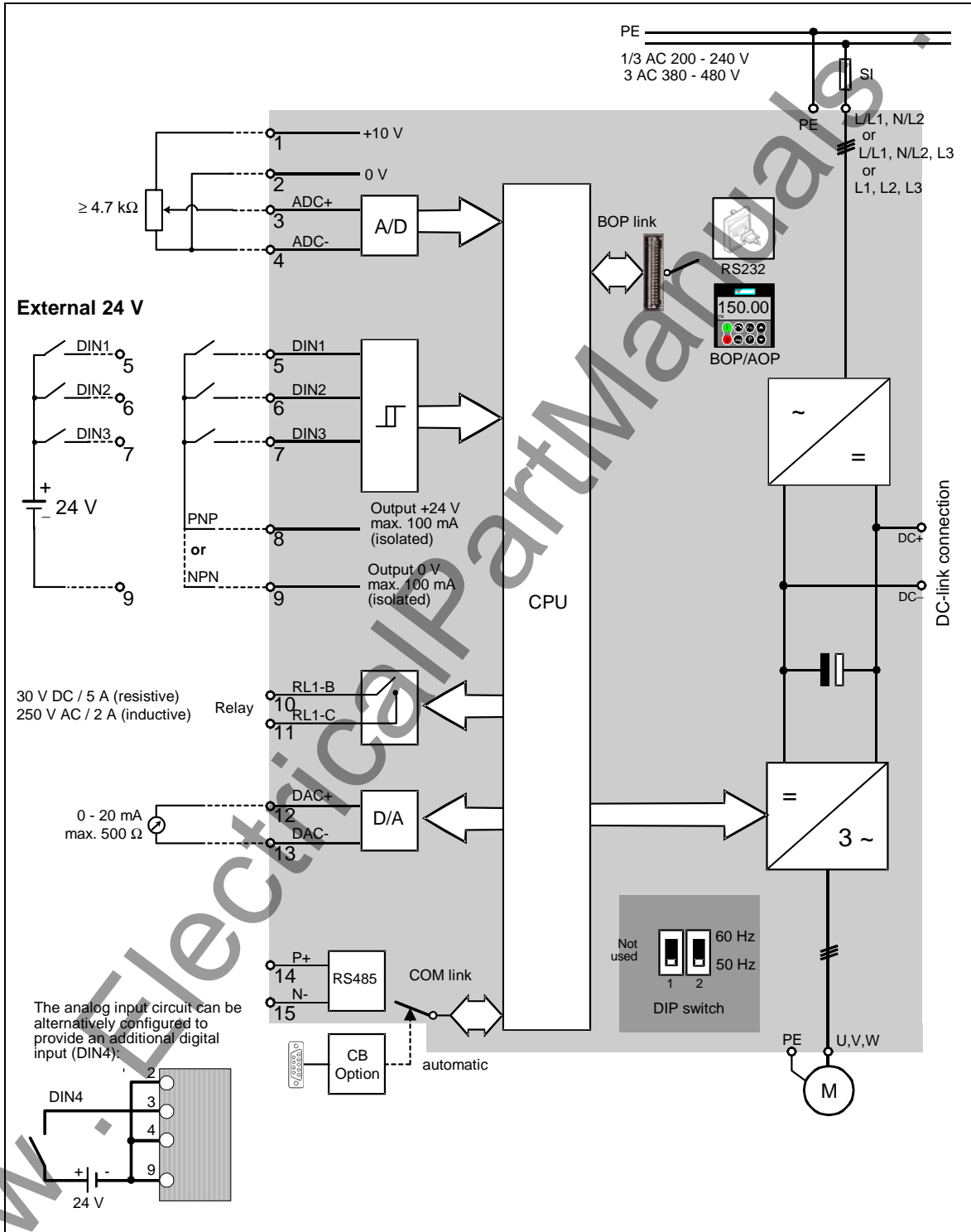

## 1.2 Power Terminals

You can gain access to the mains and motor terminals by removing the front covers.

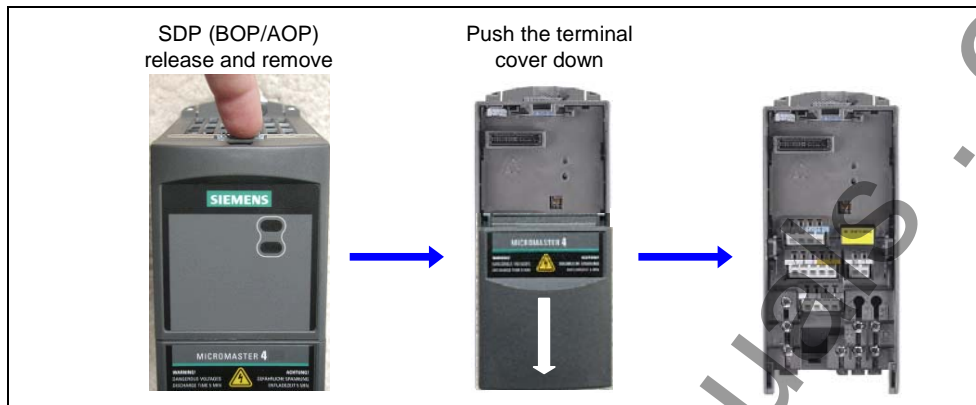

Fig. 1-1 Removing Front Covers

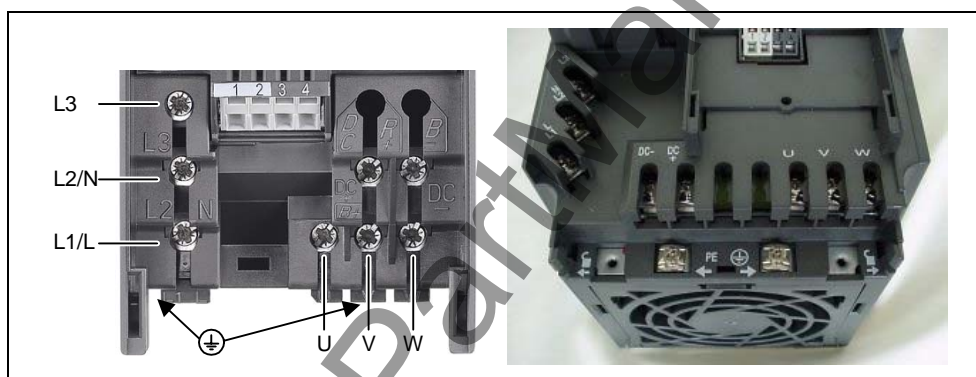
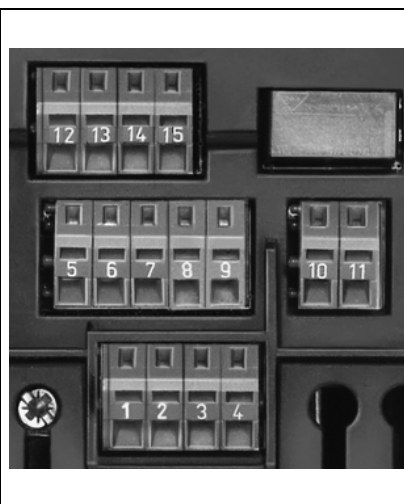

Fig. 1-2 Power Terminals

## 1.3 Control Terminals

Terminal	Designation	Function
1	-	Output +10 V
2	-	Output 0 V
3	ADC+	Analog input (+)
4	ADC-	Analog input (-)
5	DIN1	Digital input 1
6	DIN2	Digital input 2
7	DIN3	Digital input 3
8	-	Isolated output +24 V / max. 100 mA
9	-	Isolated output 0 V / max. 100 mA
10	RL1-B	Digital output / NO contact
11	RL1-C	Digital output / Changeover contact
12	DAC+	Analog output (+)
13	DAC-	Analog output (-)
14	P+	RS485 port
15	N-	RS485 port



## 2 Parameters

### 2.1 Introduction to MICROMASTER System Parameters

The layout of the parameter description is as follows.

1 Par number [index]	2 Parameter name	5 Datatype	7 Unit:	9 Min:	12 Level:
	3 CStat:	6 active:	8 Quick Comm:	10 Def:	<b>2</b>
	4 P-Group:			11 Max:	
13	Description:				

#### 1. Parameter number

Indicates the relevant parameter number. The numbers used are 4-digit numbers in the range 0000 to 9999. Numbers prefixed with an “r” indicate that the parameter is a “read-only” parameter, which displays a particular value but cannot be changed directly by specifying a different value via this parameter number (in such cases, dashes “-“ are entered at the points “Unit”, “Min”, “Def” and “Max” in the header of the parameter description.

All other parameters are prefixed with a “P”. The values of these parameters can be changed directly in the range indicated by the “Min” and “Max” settings in the header.

**[index]** indicates that the parameter is an indexed parameter and specifies the number of indices available.

#### 2. Parameter name

Indicates the name of the relevant parameter.

Certain parameter names include the following abbreviated prefixes: BI, BO, CI, and CO followed by a colon.

These abbreviations have the following meanings:

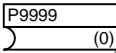
BI =  Binector input, i.e. parameter selects the source of a binary signal

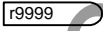
BO =  Binector output, i.e. parameter connects as a binary signal

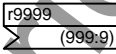
CI =  Connector input, i.e. parameter selects the source of an analog signal

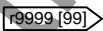
CO =  Connector output, i.e. parameter connects as an analog signal

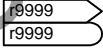
CO/BO =  Connector/Binector output, i.e. parameter connects as an analog signal and/or as a binary signal

To make use of BiCo you will need access to the full parameter list. At this level many new parameter settings are possible, including BiCo functionality. BiCo functionality is a different, more flexible way of setting and combining input and output functions. It can be used in most cases in conjunction with the simple, level 2 settings.

The BiCo system allows complex functions to be programmed. Boolean and mathematical relationships can be set up between inputs (digital, analog, serial etc.) and outputs (inverter current, frequency, analog output, relays, etc.).

3. **CStat**

Commissioning status of the parameter. Three states are possible:

Commissioning      C

Run                      U

Ready to run        T

This indicates when the parameter can be changed. One, two or all three states may be specified. If all three states are specified, this means that it is possible to change this parameter setting in all three inverter states

4. **P-Group**

Indicates the functional group of the particular.

**Note**

Parameter P0004 (parameter filter) acts as a filter and focuses access to parameters according to the functional group selected.

5. **Datatype**

The data types available are shown in the table below.

Notation	Meaning
U16	16-bit unsigned
U32	32-bit unsigned
I16	16-bit integer
I32	32-bit integer
Float	Floating point

6. **Active**

Indicates whether

- ◆ Immediately changes to the parameter values take effective immediately after they have been entered, or
- ◆ Confirm      the "P" button on the operator panel (BOP or AOP) must be pressed before the changes take effect.

7. **Unit**

Indicates the unit of measure applicable to the parameter values

8. **QuickComm**

Indicates whether or not (Yes or No) a parameter can only be changed during quick commissioning, i.e. when P0010 (parameter groups for commissioning) is set to 1 (quick commissioning).

9. **Min**

Indicates the minimum value to which the parameter can be set.

10. **Def**

Indicates the default value, i.e. the value which applies if the user does not specify a particular value for the parameter.

11. **Max**

Indicates the maximum value to which the parameter can be set.

12. **Level**

Indicates the level of user access. There are four access levels: Standard, Extended, Expert and Service. Level 4 parameters are only for service purposes and not visible with BOP/AOP. The number of parameters that appear in each functional group depends on the access level set in P0003 (user access level).

### 13. Description

The parameter description consists of the sections and contents listed below. Some of these sections and contents are optional and will be omitted on a case-to-case basis if not applicable.

<b>Description:</b>	Brief explanation of the parameter function.
<b>Diagram:</b>	Where applicable, diagram to illustrate the effects of parameters on a characteristic curve, for example
<b>Settings:</b>	List of applicable settings. These include Possible settings, Most common settings, Index and Bitfields
<b>Example:</b>	Optional example of the effects of a particular parameter setting.
<b>Dependency:</b>	Any conditions that must be satisfied in connection with this parameter. Also any particular effects, which this parameter has on other parameter(s) or which other parameters have on this one.
<b>Warning / Caution / Notice / Note:</b>	Important information which must be heeded to prevent personal injury or damage to equipment / specific information which should be heeded in order to avoid problems / information which may be helpful to the user
<b>More details:</b>	Any sources of more detailed information concerning the particular parameter.

### Operators

The following operators are used in the parameter list to represent mathematical interrelationships:

#### Arithmetic operators

+	Addition
-	Subtraction
*	Multiplication
/	Division

#### Comparison operators

>	Greater than
>=	Greater than / equal to
<	Less than
<=	Less than / equal to

#### Equivalence operators

==	Equal to
!=	Not equal to

#### Logical operators

&&	AND logic operation
	OR logic operation

## 2.2 Quick commissioning (P0010 = 1)

The following parameters are necessary for quick commissioning (P0010 = 1).

### Quick commissioning (P0010 = 1)

Par.-No.	Name	Access level	Cstat
P0100	Europe / North America	1	C
P0300	Select motor type	2	C
P0304	Motor voltage rating	1	C
P0305	Motor current rating	1	C
P0307	Motor power rating	1	C
P0308	Motor cosPhi rating	1	C
P0309	Motor efficiency rating	1	C
P0310	Motor frequency rating	1	C
P0311	Motor speed rating	1	C
P0320	Motor magnetizing current	3	CT
P0335	Motor cooling	2	CT
P0640	Motor overload factor [%]	2	CUT
P0700	Selection of command source	1	CT
P1000	Selection of frequency setpoint	1	CT
P1080	Min. frequency	1	CUT
P1082	Max. frequency	1	CT
P1120	Ramp-up time	1	CUT
P1121	Ramp-down time	1	CUT
P1135	OFF3 ramp-down time	2	CUT
P1300	Control mode	2	CT
P1910	Select motor data identification	2	CT
P3900	End of quick commissioning	1	C

When P0010 = 1 is chosen, P0003 (user access level) can be used to select the parameters to be accessed. This parameter also allows selection of a user-defined parameter list for quick commissioning.

At the end of the quick commissioning sequence, set P3900 = 1 to carry out the necessary motor calculations and clear all other parameters (not included in P0010 = 1) to their default settings.

---

#### Note

This applies only in Quick Commissioning mode.

---

### Reset to Factory default

To reset all parameters to the factory default settings; the following parameters should be set as follows:

Set P0010 = 30

Set P0970 = 1

---

#### Note

The reset process takes approximately 10 seconds to complete.

---

### Seven-segment display

The seven-segment display is structured as follows:

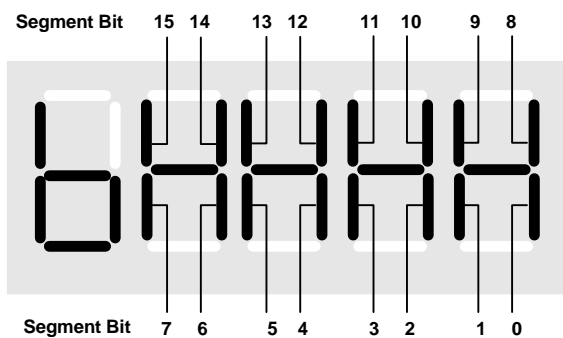

The significance of the relevant bits in the display is described in the status and control word parameters.

## 2.3 Binector Input Parameters

ParNo	Parameter name
P0731	BI: Function of digital output 1
P0800	BI: Download parameter set 0
P0801	BI: Download parameter set 1
P0810	BI: CDS bit 0 (Local / Remote)
P0840	BI: ON/OFF1
P0842	BI: ON reverse/OFF1
P0844	BI: 1. OFF2
P0845	BI: 2. OFF2
P0848	BI: 1. OFF3
P0849	BI: 2. OFF3
P0852	BI: Pulse enable
P1020	BI: Fixed freq. selection Bit 0
P1021	BI: Fixed freq. selection Bit 1
P1022	BI: Fixed freq. selection Bit 2
P1035	BI: Enable MOP (UP-command)
P1036	BI: Enable MOP (DOWN-command)
P1055	BI: Enable JOG right
P1056	BI: Enable JOG left

ParNo	Parameter name
P1074	BI: Disable additional setpoint
P1110	BI: Inhibit neg. freq. setpoint
P1113	BI: Reverse
P1124	BI: Enable JOG ramp times
P1140	BI: RFG enable
P1141	BI: RFG start
P1142	BI: RFG enable setpoint
P1230	BI: Enable DC braking
P2103	BI: 1. Faults acknowledgement
P2104	BI: 2. Faults acknowledgement
P2106	BI: External fault
P2200	BI: Enable PID controller
P2220	BI: Fixed PID setp. select Bit 0
P2221	BI: Fixed PID setp. select Bit 1
P2222	BI: Fixed PID setp. select Bit 2
P2235	BI: Enable PID-MOP (UP-cmd)
P2236	BI: Enable PID-MOP (DOWN-cmd)

## 2.4 Connector Input Parameters

ParNo	Parameter name
P0771	CI: DAC
P1070	CI: Main setpoint
P1071	CI: Main setpoint scaling
P1075	CI: Additional setpoint
P1076	CI: Additional setpoint scaling
P2016[4]	CI: PZD to BOP link (USS)

ParNo	Parameter name
P2019[4]	CI: PZD to COM link (USS)
P2051[4]	CI: PZD to CB
P2253	CI: PID setpoint
P2254	CI: PID trim source
P2264	CI: PID feedback

## 2.5 Binector Output Parameters

ParNo	Parameter name
r2032	BO: CtrlWrd1 from BOP link (USS)
r2033	BO: CtrlWrd2 from BOP link (USS)
r2036	BO: CtrlWrd1 from COM link (USS)

ParNo	Parameter name
r2037	BO: CtrlWrd2 from COM link (USS)
r2090	BO: Control word 1 from CB
r2091	BO: Control word 2 from CB

## 2.6 Connector Output Parameters

ParNo	Parameter name
r0020	CO: Freq. setpoint before RFG
r0021	CO: Act. frequency
r0024	CO: Act. output frequency
r0025	CO: Act. output voltage
r0026	CO: Act. DC-link voltage
r0027	CO: Act. output current
r0034	CO: Motor temperature (i2t)
r0036	CO: Inverter overload utilization
r0037	CO: Inverter temperature [°C]
r0039	CO: Energy consumpt. meter [kWh]
r0067	CO: Act. output current limit
r0071	CO: Max. output voltage
r0078	CO: Act. current Isq
r0084	CO: Act. air gap flux
r0086	CO: Act. active current
r0395	CO: Total stator resistance [%]
r0755	CO: Act. ADC after scal. [4000h]
r0947[8]	CO: Last fault code
r0948[12]	CO: Fault time
r0949[8]	CO: Fault value
r1024	CO: Act. fixed frequency
r1050	CO: Act. Output freq. of the MOP
r1078	CO: Total frequency setpoint

ParNo	Parameter name
r1079	CO: Selected frequency setpoint
r1114	CO: Freq. setp. after dir. ctrl.
r1119	CO: Freq. setpoint before RFG
r1170	CO: Frequency setpoint after RFG
r1242	CO: Switch-on level of V <sub>dc</sub> -max
r1315	CO: Total boost voltage
r1337	CO: V/f slip frequency
r1343	CO: I <sub>max</sub> controller freq. output
r1344	CO: I <sub>max</sub> controller volt. output
r1801	CO: Act. pulse frequency
r2015[4]	CO: PZD from BOP link (USS)
r2018[4]	CO: PZD from COM link (USS)
r2050[4]	CO: PZD from CB
r2110[4]	CO: Warning number
r2224	CO: Act. fixed PID setpoint
r2250	CO: Output setpoint of PID-MOP
r2260	CO: PID setpoint after PID-RFG
r2262	CO: Filtered PID setp. after RFG
r2266	CO: PID filtered feedback
r2272	CO: PID scaled feedback
r2273	CO: PID error
r2294	CO: Act. PID output

## 2.7 Connector/Binector Output Parameters

ParNo	Parameter name
r0019	CO/BO: BOP control word
r0052	CO/BO: Act. status word 1
r0053	CO/BO: Act. status word 2
r0054	CO/BO: Act. control word 1
r0055	CO/BO: Act. control word 2
r0056	CO/BO: Status of motor control

ParNo	Parameter name
r0722	CO/BO: Binary input values
r0747	CO/BO: State of digital outputs
r0751	CO/BO: Status word of ADC
r0785	CO/BO: Status word of DAC
r1204	CO/BO: Status word: Flying start
r2197	CO/BO: Monitoring word 1

### 3 Parameter Description

**Note**

Level 4 Parameters are not visible with BOP or AOP. They are only for service purposes.

#### 3.1 Common parameters

<b>r0000</b>	<b>Drive display</b>	<b>Datatype:</b> U16	<b>Unit:</b> -	<b>Min:</b> - <b>Def:</b> - <b>Max:</b> -	<b>Level</b> <b>1</b>
	<b>P-Group:</b> ALWAYS				
	Displays the user selected output as defined in P0005.				

**Note:**

Pressing the "Fn" button for 2 seconds allows the user to view the values of DC link voltage, output frequency, output voltage, output current, and chosen r0000 setting (defined in P0005).

<b>r0002</b>	<b>Drive state</b>	<b>Datatype:</b> U16	<b>Unit:</b> -	<b>Min:</b> - <b>Def:</b> - <b>Max:</b> -	<b>Level</b> <b>2</b>
	<b>P-Group:</b> COMMANDS				
	Displays actual drive state.				

**Possible Settings:**

- 0 Commissioning mode (P0010 != 0)
- 1 Drive ready
- 2 Drive fault active
- 3 Drive starting (DC-link precharging)
- 4 Drive running
- 5 Stopping (ramping down)

**Dependency:**

State 3 visible only while precharging DC link, and when externally powered communications board is fitted.

<b>P0003</b>	<b>User access level</b>	<b>Datatype:</b> U16	<b>Unit:</b> -	<b>Min:</b> 0 <b>Def:</b> 1 <b>Max:</b> 4	<b>Level</b> <b>1</b>
	<b>CStat:</b> CUT <b>P-Group:</b> ALWAYS	<b>Active:</b> first confirm	<b>QuickComm.:</b> No		
	Defines user access level to parameter sets. The default setting (standard) is sufficient for most simple applications.				

**Possible Settings:**

- 0 User defined parameter list - see P0013 for details on use
- 1 Standard: Allows access into most frequently used parameters.
- 2 Extended: Allows extended access e.g. to inverter I/O functions.
- 3 Expert: For expert use only.
- 4 Service: Only for use by authorized service personal - password protected.

<b>P0004</b>	<b>Parameter filter</b>	<b>Datatype:</b> U16	<b>Unit:</b> -	<b>Min:</b> 0 <b>Def:</b> 0 <b>Max:</b> 22	<b>Level</b> <b>1</b>
	<b>CStat:</b> CUT <b>P-Group:</b> ALWAYS	<b>Active:</b> first confirm	<b>QuickComm.:</b> No		
	Filters available parameters according to functionality to enable a more focussed approach to commissioning.				

**Possible Settings:**

- 0 All parameters
- 2 Inverter
- 3 Motor
- 7 Commands, binary I/O
- 8 ADC and DAC
- 10 Setpoint channel / RFG
- 12 Drive features
- 13 Motor control
- 20 Communication
- 21 Alarms / warnings / monitoring
- 22 Technology controller (e.g. PID)

**Example:**

P0004 = 22 specifies that only PID parameters will be visible.

**Dependency:**

The parameters are sub-divided into groups (P-Group) according to their functionality. This increases the transparency and allows a parameter to be quickly searched for. Furthermore, parameter P0004 can be used to control the ability to be visualized for the operator panel.

Value	P-Group	Group	Parameter area
0	ALWAYS	All parameters	
2	INVERTER	Drive inverter parameters	0200 .... 0299
3	MOTOR	Motor parameters	0300 ... 0399 + 0600 .... 0699
7	COMMANDS	Control commands, digital I/O	0700 .... 0749 + 0800 ... 0899
8	TERMINAL	Analog inputs/outputs	0750 .... 0799
10	SETPPOINT	Setpoint channel and ramp-function gen.	1000 .... 1199
12	FUNC	Drive inverter functions	1200 .... 1299
13	CONTROL	Motor open-loop/closed-loop control	1300 .... 1799
20	COMM	Communications	2000 .... 2099
21	ALARMS	Faults, warnings, monitoring functions	2100 .... 2199
22	TECH	Technological controller (PID controller)	2200 .... 2399

Parameters marked "Quick Comm: Yes" in the parameter header can only be set when P0010 = 1 (Quick Commissioning).

<b>P0005</b>	<b>Display selection</b>			<b>Min:</b> 2	Level <b>2</b>
	<b>CStat:</b> CUT	<b>Datatype:</b> U16	<b>Unit:</b> -	<b>Def:</b> 21	
	<b>P-Group:</b> FUNC	<b>Active:</b> first confirm	<b>QuickComm.:</b> No	<b>Max:</b> 4000	

Selects display for parameter r0000 (drive display).

**Common Settings:**

- 21 Actual frequency
- 25 Output voltage
- 26 DC link voltage
- 27 Output current

**Notice:**

These settings refer to read only parameter numbers ("rxxxx").

**Details:**

See relevant "rxxxx" parameter descriptions.

<b>P0006</b>	<b>Display mode</b>			<b>Min:</b> 0	Level <b>3</b>
	<b>CStat:</b> CUT	<b>Datatype:</b> U16	<b>Unit:</b> -	<b>Def:</b> 2	
	<b>P-Group:</b> FUNC	<b>Active:</b> first confirm	<b>QuickComm.:</b> No	<b>Max:</b> 4	

Defines mode of display for r0000 (drive display).

**Possible Settings:**

- 0 In Ready state alternate between setpoint and output frequency. In run display output frequency
- 1 In Ready state display setpoint. In run display output frequency.
- 2 In Ready state alternate between P0005 value and r0020 value. In run display P0005 value
- 3 In Ready state alternate between r0002 value and r0020 value. In run display r0002 value
- 4 In all states just display P0005

**Note:**

- When inverter is not running, the display alternates between the values for "Not Running" and "Running".
- Per default, the setpoint and actual frequency values are displayed alternately.

<b>P0007</b>	<b>Backlight delay time</b>			<b>Min:</b> 0	Level <b>3</b>
	<b>CStat:</b> CUT	<b>Datatype:</b> U16	<b>Unit:</b> -	<b>Def:</b> 0	
	<b>P-Group:</b> FUNC	<b>Active:</b> first confirm	<b>QuickComm.:</b> No	<b>Max:</b> 2000	

Defines time period after which the backlight display turns off if no operator keys have been pressed.

**Value:**

P0007 = 0:  
Backlight always on (default state).

P0007 = 1 - 2000:  
Number of seconds after which the backlight will turn off.

<b>P0010</b>	<b>Commissioning parameter</b>				Level <b>1</b>
	<b>CStat:</b> CT	<b>Datatype:</b> U16	<b>Unit:</b> -	<b>Min:</b> 0 <b>Def:</b> 0	
	<b>P-Group:</b> ALWAYS	<b>Active:</b> first confirm	<b>QuickComm.:</b> No	<b>Max:</b> 30	

Filters parameters so that only those related to a particular functional group are selected.

**Possible Settings:**

- 0 Ready
- 1 Quick commissioning
- 2 Inverter
- 29 Download
- 30 Factory setting

**Dependency:**

- Reset to 0 for inverter to run.
- P0003 (user access level) also determines access to parameters.

**Note:**

P0010 = 1

The inverter can be commissioned very quickly and easily by setting P0010 = 1. After that only the important parameters (e.g.: P0304, P0305, etc.) are visible. The value of these parameters must be entered one after the other. The end of quick commissioning and the start of internal calculation will be done by setting P3900 = 1 - 3. Afterward parameter P0010 and P3900 will be reset to zero automatically.

P0010 = 2

For service purposes only.

P0010 = 29

To transfer a parameter file via PC tool (e.g.: DriveMonitor, STARTER) parameter P0010 will be set to 29 by the PC tool. When download has been finished PC tool resets parameter P0010 to zero.

P0010 = 30

When resetting the parameters of inverter P0010 must be set to 30. Resetting of the parameters will be started by setting parameter P0970 = 1. The inverter will automatically reset all its parameters to their default settings. This can prove beneficial if you experience problems during parameter setup and wish to start again. Duration of factory setting will take about 60 s.

<b>P0011</b>	<b>Lock for user defined parameter</b>				Level <b>3</b>
	<b>CStat:</b> CUT	<b>Datatype:</b> U16	<b>Unit:</b> -	<b>Min:</b> 0 <b>Def:</b> 0	
	<b>P-Group:</b> FUNC	<b>Active:</b> first confirm	<b>QuickComm.:</b> No	<b>Max:</b> 65535	

**Details:**

See parameter P0013 (user defined parameter)

<b>P0012</b>	<b>Key for user defined parameter</b>				Level <b>3</b>
	<b>CStat:</b> CUT	<b>Datatype:</b> U16	<b>Unit:</b> -	<b>Min:</b> 0 <b>Def:</b> 0	
	<b>P-Group:</b> FUNC	<b>Active:</b> first confirm	<b>QuickComm.:</b> No	<b>Max:</b> 65535	

**Details:**

See parameter P0013 (user defined parameter).

<b>P0013[20]</b>	<b>User defined parameter</b>				Level <b>3</b>
	<b>CStat:</b> CUT	<b>Datatype:</b> U16	<b>Unit:</b> -	<b>Min:</b> 0 <b>Def:</b> 0	
	<b>P-Group:</b> FUNC	<b>Active:</b> first confirm	<b>QuickComm.:</b> No	<b>Max:</b> 65535	

Defines a limited set of parameters to which the end user will have access.

Instructions for use:

1. Set P0003 = 3 (expert user)
2. Go to P0013 indices 0 to 16 (user list)
3. Enter into P0013 index 0 to 16 the parameters required to be visible in the user-defined list. The following values are fixed and cannot be changed:
  - P0013 index 19 = 12 (key for user defined parameter)
  - P0013 index 18 = 10 (commissioning parameter filter)
  - P0013 index 17 = 3 (user access level)
4. Set P0003 = 0 to activate the user defined parameter.

**Index:**

P0013[0] : 1st user parameter  
 P0013[1] : 2nd user parameter  
 P0013[2] : 3rd user parameter  
 P0013[3] : 4th user parameter  
 P0013[4] : 5th user parameter  
 P0013[5] : 6th user parameter  
 P0013[6] : 7th user parameter  
 P0013[7] : 8th user parameter  
 P0013[8] : 9th user parameter  
 P0013[9] : 10th user parameter  
 P0013[10] : 11th user parameter  
 P0013[11] : 12th user parameter  
 P0013[12] : 13th user parameter  
 P0013[13] : 14th user parameter  
 P0013[14] : 15th user parameter  
 P0013[15] : 16th user parameter  
 P0013[16] : 17th user parameter  
 P0013[17] : 18th user parameter  
 P0013[18] : 19th user parameter  
 P0013[19] : 20th user parameter

**Dependency:**

First, set P0011 ("lock") to a different value than P0012 ("key") to prevent changes to user-defined parameter. Then, set P0003 to 0 to activate the user-defined list.

When locked and the user-defined parameter is activated, the only way to exit the user-defined parameter (and view other parameters) is to set P0012 ("key") to the value in P0011 ("lock").

**Note:**

- Alternatively, set P0010 = 30 (commissioning parameter filter = factory setting) and P0970 = 1 (factory reset) to perform a complete factory reset.
- The default values of P0011 ("lock") and P0012 ("key") are the same.

<b>P0014[3]</b>	<b>Store mode</b>			<b>Min:</b> 0	<b>Level</b> <b>3</b>
	<b>CStat:</b> UT	<b>Datatype:</b> U16	<b>Unit:</b> -	<b>Def:</b> 0	
	<b>P-Group:</b> -	<b>Active:</b> first confirm	<b>QuickComm.:</b> No	<b>Max:</b> 1	

Sets the store mode for parameters ("volatile" (RAM) or "nonvolatile" (EEPROM)).

**Possible Settings:**

- 0 Volatile (RAM)
- 1 Nonvolatile (EEPROM)

**Index:**

P0014[0] : Serial interface COM link  
 P0014[1] : Serial interface BOP link  
 P0014[2] : PROFIBUS / CB

**Note:**

1. With the BOP the parameter will always be stored in the EEPROM.
2. P0014 itself will always be stored in the EEPROM.
3. P0014 will not be changed by performing a factory reset (P0010 = 30 and P0971 = 1).
4. P0014 can be transferred during a DOWNLOAD (P0010 = 29).
5. If "Store request via USS/CB = volatile (RAM)" and "P0014[x] = volatile (RAM)", you can make a transfer of all parameter values into the nonvolatile memory via P0971.
6. If "Store request via USS/CB" and P0014[x] are not consistent, the setting of P14[x] = "store nonvolatile (EEPROM)" has always higher priority.

Store request via USS/CB	Value of P0014[x]	Result
EEPROM	RAM	EEPROM
EEPROM	EEPROM	EEPROM
RAM	RAM	RAM
RAM	EEPROM	EEPROM

### 3.2 Diagnosis parameters

<b>r0018</b>	<b>Firmware version</b>	<b>Datatype:</b> Float	<b>Unit:</b> -	<b>Min:</b> - <b>Def:</b> - <b>Max:</b> -	<b>Level</b> <b>1</b>
	<b>P-Group:</b> INVERTER				

Displays version number of installed firmware.

<b>r0019</b>	<b>CO/BO: BOP control word</b>	<b>Datatype:</b> U16	<b>Unit:</b> -	<b>Min:</b> - <b>Def:</b> - <b>Max:</b> -	<b>Level</b> <b>3</b>
	<b>P-Group:</b> COMMANDS				

Displays status of operator panel commands.

The settings below are used as the "source" codes for keypad control when connecting to BICO input parameters.

**Bitfields:**

Bit00	ON/OFF1	0	NO	1	YES
Bit01	OFF2: Electrical stop	0	YES	1	NO
Bit08	JOG right	0	NO	1	YES
Bit11	Reverse (setpoint inversion)	0	NO	1	YES
Bit13	Motor potentiometer MOP up	0	NO	1	YES
Bit14	Motor potentiometer MOP down	0	NO	1	YES

**Note:**

When BICO technology is used to allocate functions to panel buttons, this parameter displays the actual status of the relevant command.

The following functions can be "connected" to individual buttons:

- ON/OFF1,
- OFF2,
- JOG,
- REVERSE,
- INCREASE,
- DECREASE

<b>r0020</b>	<b>CO: Freq. setpoint before RFG</b>	<b>Datatype:</b> Float	<b>Unit:</b> Hz	<b>Min:</b> - <b>Def:</b> - <b>Max:</b> -	<b>Level</b> <b>3</b>
	<b>P-Group:</b> CONTROL				

Displays actual frequency setpoint (input from ramp function generator).

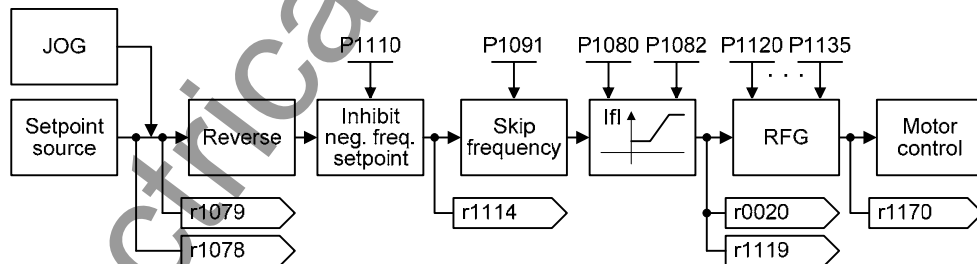

<b>r0021</b>	<b>CO: Act. frequency</b>	<b>Datatype:</b> Float	<b>Unit:</b> Hz	<b>Min:</b> - <b>Def:</b> - <b>Max:</b> -	<b>Level</b> <b>2</b>
	<b>P-Group:</b> CONTROL				

Displays actual inverter output frequency (r0021) excluding slip compensation, resonance damping and frequency limitation.

<b>r0022</b>	<b>Act. rotor speed</b>	<b>Datatype:</b> Float	<b>Unit:</b> 1/min	<b>Min:</b> - <b>Def:</b> - <b>Max:</b> -	<b>Level</b> <b>3</b>
	<b>P-Group:</b> CONTROL				

Displays calculated rotor speed based on inverter output frequency [Hz] x 120 / number of poles.

$$r0022 [1/min] = r0021 [Hz] \cdot \frac{60}{r0313}$$

**Note:**

This calculation makes no allowance for load-dependent slip.

<b>r0024</b>	<b>CO: Act. Inv. output frequency</b>	<b>Datatype:</b> Float	<b>Unit:</b> Hz	<b>Min:</b> - <b>Def:</b> - <b>Max:</b> -	<b>Level</b> <b>3</b>
	<b>P-Group:</b> CONTROL				

Displays actual output frequency. Slip compensation, resonance damping and frequency limitation are included.

<b>r0025</b>	<b>CO: Act. output voltage</b>	<b>Datatype:</b> Float	<b>Unit:</b> V	<b>Min:</b> - <b>Def:</b> - <b>Max:</b> -	Level <b>2</b>
	<b>P-Group:</b> CONTROL				

Displays [rms] voltage applied to motor.

<b>r0026</b>	<b>CO: Act. DC-link volt.</b>	<b>Datatype:</b> Float	<b>Unit:</b> V	<b>Min:</b> - <b>Def:</b> - <b>Max:</b> -	Level <b>2</b>
	<b>P-Group:</b> INVERTER				

Displays DC-link voltage.

		Mains	
		200 - 240 V	380 - 480 V
U <sub>DC_max_trip</sub>	F0002	410 V	820 V
U <sub>DC_min_trip</sub>	F0003	205 V	410 V
U <sub>DC_max_warn</sub>	A0502	r1242	
U <sub>DC_max_ctrl</sub>	(P1240)		
U <sub>DC_Comp</sub>	(P1236)	0.98 · r1242	

<b>r0027</b>	<b>CO: Act. output current</b>	<b>Datatype:</b> Float	<b>Unit:</b> A	<b>Min:</b> - <b>Def:</b> - <b>Max:</b> -	Level <b>2</b>
	<b>P-Group:</b> CONTROL				

Displays [rms] value of motor current [A].

<b>r0034</b>	<b>CO: Motor temperature (i2t)</b>	<b>Datatype:</b> Float	<b>Unit:</b> %	<b>Min:</b> - <b>Def:</b> - <b>Max:</b> -	Level <b>2</b>
	<b>P-Group:</b> MOTOR				

Displays calculated motor temperature (I2t model) as [%] of the maximum permissible value.

**Note:**

The maximum permissible operating temperature (i2t) of the motor is given, if the parameter r0034 has reached the value of P0614. In this case, the motor will attempt to reduce the motor loading as defined in P0610 (motor I2t temperature reaction).

<b>r0036</b>	<b>CO: Inverter overload utilization</b>	<b>Min:</b> -	<b>Level</b>
	<b>Datatype:</b> Float <b>Unit:</b> %	<b>Def:</b> -	<b>4</b>
<b>P-Group:</b> INVERTER		<b>Max:</b> -	

Displays inverter overload utilization calculated via I2t model.

The actual I2t value relative to the max. possible I2t value supplies utilization in [%].

If the current exceeds the threshold for P0294 (inverter I2t overload warning), alarm A0505 (inverter I2t) is generated and the output current of the inverter reduced via P0290 (inverter overload reaction).

If 100 % utilization is exceeded, alarm F0005 (inverter I2t) is tripped.

**Example:**

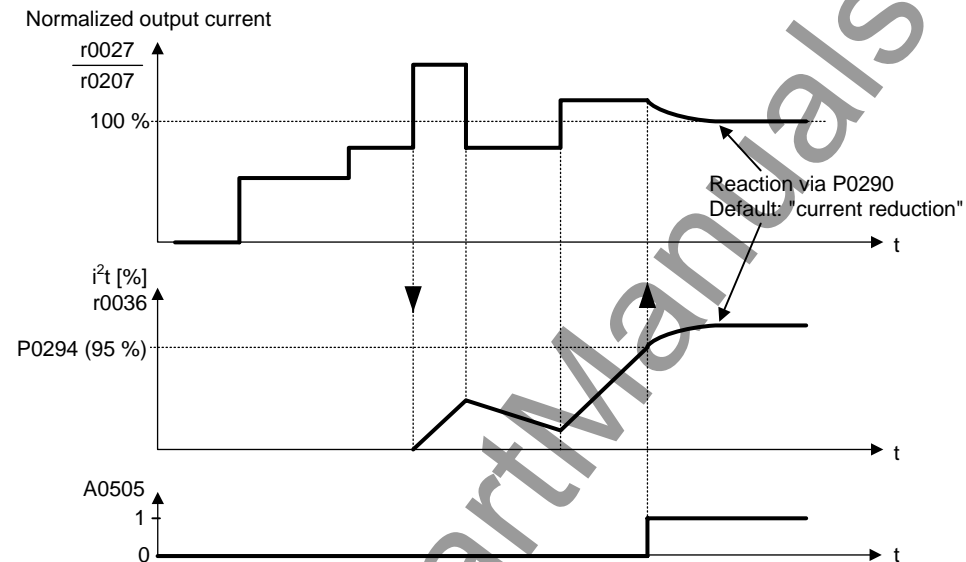

**Dependency:**

r0036 > 0:  
If the nominal current of the inverter is exceeded, utilization will be displayed. Otherwise, 0 % utilization is displayed.

<b>r0037</b>	<b>CO: Inverter temperature [°C]</b>	<b>Min:</b> -	<b>Level</b>
	<b>Datatype:</b> Float <b>Unit:</b> °C	<b>Def:</b> -	<b>3</b>
<b>P-Group:</b> INVERTER		<b>Max:</b> -	

Displays internal inverter heatsink temperature.

<b>r0039</b>	<b>CO: Energy consumpt. meter [kWh]</b>	<b>Min:</b> -	<b>Level</b>
	<b>Datatype:</b> Float <b>Unit:</b> kWh	<b>Def:</b> -	<b>2</b>
<b>P-Group:</b> INVERTER		<b>Max:</b> -	

Displays electrical energy used by inverter since display was last reset (see P0040 - reset energy consumption meter).

$$r0039 = \int_0^{t_{act}} P_W \cdot dt = \int_0^{t_{act}} \sqrt{3} \cdot u \cdot i \cdot \cos \varphi \cdot dt$$

**Dependency:**

Value is reset when P0040 = 1 (reset energy consumption meter).

<b>P0040</b>	<b>Reset energy consumption meter</b>	<b>Min:</b> 0	<b>Level</b>
	<b>CStat:</b> CT <b>Datatype:</b> U16 <b>Unit:</b> -	<b>Def:</b> 0	<b>2</b>
<b>P-Group:</b> INVERTER <b>Active:</b> first confirm <b>QuickComm.:</b> No		<b>Max:</b> 1	

Resets value of parameter r0039 (energy consumption meter) to zero.

**Possible Settings:**

- 0 No reset
- 1 Reset r0039 to 0

**Dependency:**

No reset until "P" is pressed.

<b>r0052</b>	<b>CO/BO: Act. status word 1</b>	<b>Min:</b> -	<b>Level</b>
	<b>Datatype:</b> U16 <b>Unit:</b> -	<b>Def:</b> -	<b>2</b>
<b>P-Group:</b> COMMANDS		<b>Max:</b> -	

Displays first active status word of inverter (bit format) and can be used to diagnose inverter status.

**Bitfields:**

Bit00	Drive ready	0	NO	1	YES
Bit01	Drive ready to run	0	NO	1	YES
Bit02	Drive running	0	NO	1	YES
Bit03	Drive fault active	0	NO	1	YES
Bit04	OFF2 active	0	YES	1	NO
Bit05	OFF3 active	0	YES	1	NO
Bit06	ON inhibit active	0	NO	1	YES
Bit07	Drive warning active	0	NO	1	YES
Bit08	Deviation setpoint / act. value	0	YES	1	NO
Bit09	PZD control	0	NO	1	YES
Bit10	Maximum frequency reached	0	NO	1	YES
Bit11	Warning: Motor current limit	0	YES	1	NO
Bit12	Motor holding brake active	0	NO	1	YES
Bit13	Motor overload	0	YES	1	NO
Bit14	Motor runs right	0	NO	1	YES
Bit15	Inverter overload	0	YES	1	NO

**Dependency:**

r0052 Bit00 - Bit02:

State-sequence diagram after Power On or ON/OFF1 respectively: ==> see below

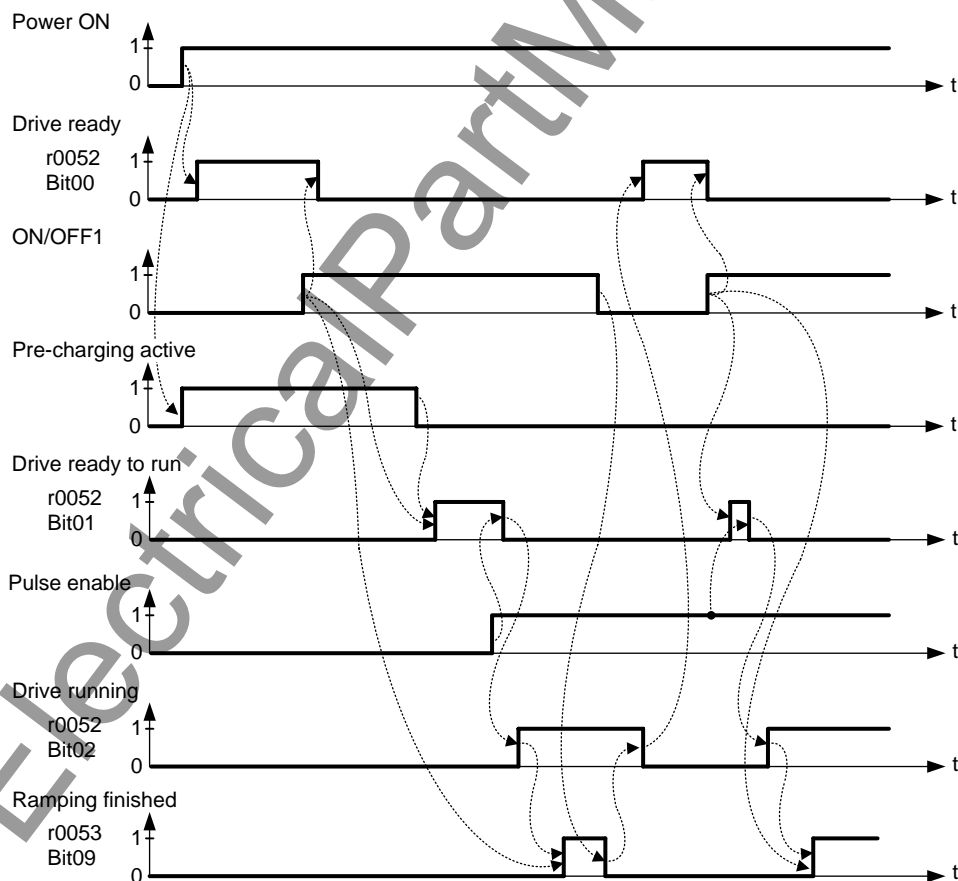

r0052 Bit03 "Drive fault active":

Output of Bit3 (Fault) will be inverted on digital output (Low = Fault, High = No Fault).

r0052 Bit08 "Deviation setpoint / act. value" ==> see parameter P2164

r0052 Bit10 "f\_act >= P1082 (f\_max)" ==> see parameter P1082

r0052 Bit12 "Motor holding brake active" ==> see parameter P1215

r0052 Bit14 "Motor runs right" ==> see below

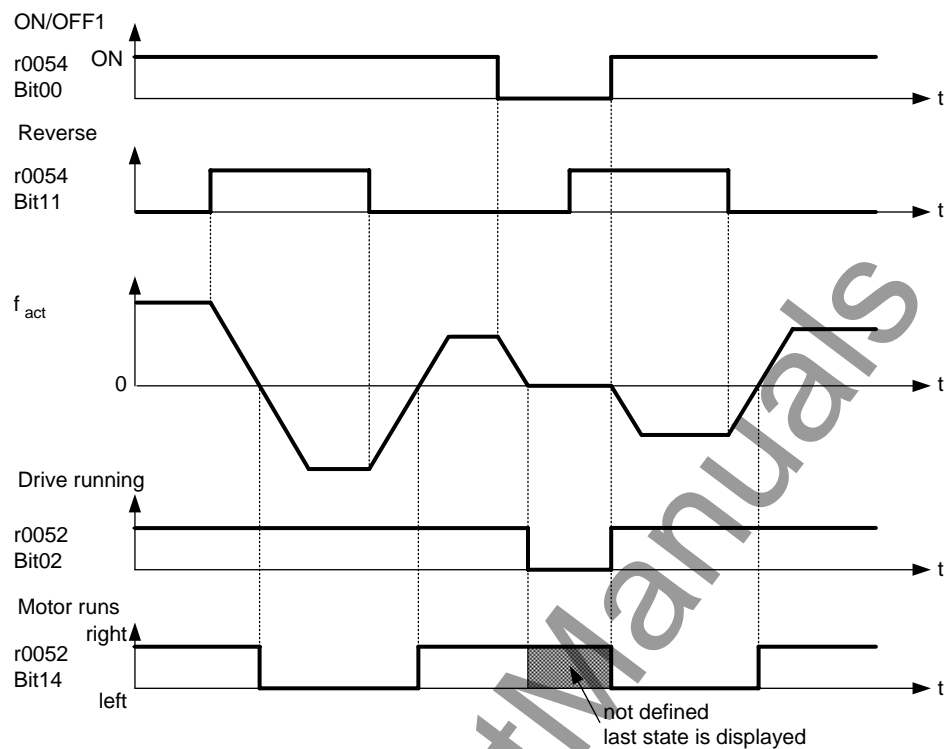

**Details:**

The 7-segment display of the bit-parameters (binary parameters) is explained in the Introduction of the Parameter List.

<b>r0053</b>	<b>CO/BO: Act. status word 2</b>	<b>Datatype:</b> U16	<b>Unit:</b> -	<b>Min:</b> -	<b>Def:</b> -	<b>Max:</b> -	<b>Level</b>
	<b>P-Group:</b> COMMANDS						<b>2</b>

Displays second status word of inverter (in bit format).

**Bitfields:**

Bit00	DC brake active	0	NO	1	YES
Bit01	f <sub>act</sub> > P2167 (f <sub>off</sub> )	0	NO	1	YES
Bit02	f <sub>act</sub> <= P1080 (f <sub>min</sub> )	0	NO	1	YES
Bit03	Act. current r0027 > P2170	0	NO	1	YES
Bit04	f <sub>act</sub> > P2155 (f <sub>1</sub> )	0	NO	1	YES
Bit05	f <sub>act</sub> <= P2155 (f <sub>1</sub> )	0	NO	1	YES
Bit06	f <sub>act</sub> >= setpoint	0	NO	1	YES
Bit07	Act. Vdc r0026 < P2172	0	NO	1	YES
Bit08	Act. Vdc r0026 > P2172	0	NO	1	YES
Bit09	Ramping finished	0	NO	1	YES
Bit10	PID output r2294 == P2292 (PID <sub>min</sub> )	0	NO	1	YES
Bit11	PID output r2294 == P2291 (PID <sub>max</sub> )	0	NO	1	YES
Bit14	Download data set 0 from AOP	0	NO	1	YES
Bit15	Download data set 1 from AOP	0	NO	1	YES

**Note:**

- r0053 Bit00 ==> see parameter P1233
- r0053 Bit01 ==> see parameter P2167
- r0053 Bit02 ==> see parameter P1080
- r0053 Bit03 ==> see parameter P2170
- r0053 Bit04 ==> see parameter P2155
- r0053 Bit05 ==> see parameter P2155
- r0053 Bit06 ==> see parameter P2150
- r0053 Bit07 ==> see parameter P2172
- r0053 Bit08 ==> see parameter P2172

r0053 Bit09 "Ramping finished" ==> see below

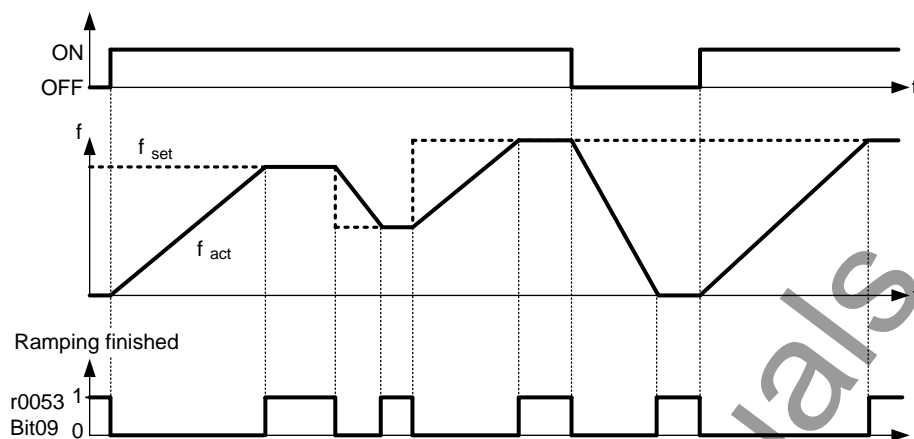

**Details:**

See description of seven-segment display given in the "Introduction to MICROMASTER System Parameters" in this manual.

<b>r0054</b>	<b>CO/BO: Act. control word 1</b>	<b>Datatype:</b> U16	<b>Unit:</b> -	<b>Min:</b> -	<b>Def:</b> -	<b>Max:</b> -	<b>Level</b>
	<b>P-Group:</b> COMMANDS						<b>3</b>

Displays first control word of inverter and can be used to diagnose which commands are active.

**Bitfields:**

Bit00	ON/OFF1	0	NO	1	YES
Bit01	OFF2: Electrical stop	0	YES	1	NO
Bit02	OFF3: Fast stop	0	YES	1	NO
Bit03	Pulses enabled	0	NO	1	YES
Bit04	RFG enable	0	NO	1	YES
Bit05	RFG start	0	NO	1	YES
Bit06	Setpoint enable	0	NO	1	YES
Bit07	Fault acknowledge	0	NO	1	YES
Bit08	JOG right	0	NO	1	YES
Bit09	JOG left	0	NO	1	YES
Bit10	Control from PLC	0	NO	1	YES
Bit11	Reverse (setpoint inversion)	0	NO	1	YES
Bit13	Motor potentiometer MOP up	0	NO	1	YES
Bit14	Motor potentiometer MOP down	0	NO	1	YES
Bit15	Local / Remote	0	NO	1	YES

**Details:**

See description of seven-segment display given in the "Introduction to MICROMASTER System Parameters" in this manual.

<b>r0055</b>	<b>CO/BO: Act. control word 2</b>	<b>Datatype:</b> U16	<b>Unit:</b> -	<b>Min:</b> -	<b>Def:</b> -	<b>Max:</b> -	<b>Level</b>
	<b>P-Group:</b> COMMANDS						<b>3</b>

Displays additional control word of inverter and can be used to diagnose which commands are active.

**Bitfields:**

Bit00	Fixed frequency Bit 0	0	NO	1	YES
Bit01	Fixed frequency Bit 1	0	NO	1	YES
Bit02	Fixed frequency Bit 2	0	NO	1	YES
Bit08	PID enabled	0	NO	1	YES
Bit09	DC brake enabled	0	NO	1	YES
Bit13	External fault 1	0	YES	1	NO

**Details:**

See description of seven-segment display given in the "Introduction to MICROMASTER System Parameters" in this handbook.

<b>r0056</b>	<b>CO/BO: Status of motor control</b>	<b>Min:</b> -	<b>Level</b> <b>3</b>	
	<b>Datatype:</b> U16	<b>Unit:</b> -		<b>Def:</b> -
	<b>P-Group:</b> CONTROL			<b>Max:</b> -

Displays status of motor control (MM420: V/f status), which can be used to diagnose inverter status.

**Bitfields:**

Bit00	Init. control finished	0	NO	1	YES
Bit01	Motor demagnetizing finished	0	NO	1	YES
Bit02	Pulses enabled	0	NO	1	YES
Bit03	Voltage soft start selected	0	NO	1	YES
Bit04	Motor excitation finished	0	NO	1	YES
Bit05	Starting boost active	0	NO	1	YES
Bit06	Acceleration boost active	0	NO	1	YES
Bit07	Frequency is negative	0	NO	1	YES
Bit08	Field weakening active	0	NO	1	YES
Bit09	Volts setpoint limited	0	NO	1	YES
Bit10	Slip frequency limited	0	NO	1	YES
Bit11	F_out > F_max Freq. limited	0	NO	1	YES
Bit12	Phase reversal selected	0	NO	1	YES
Bit13	I-max controller active	0	NO	1	YES
Bit14	Vdc-max controller active	0	NO	1	YES
Bit15	KIB (Vdc-min control) active	0	NO	1	YES

**Details:**

See description of seven-segment display given in the introduction.

<b>r0067</b>	<b>CO: Act. output current limit</b>	<b>Min:</b> -	<b>Level</b> <b>3</b>	
	<b>Datatype:</b> Float	<b>Unit:</b> A		<b>Def:</b> -
	<b>P-Group:</b> CONTROL			<b>Max:</b> -

Displays valid maximum output current of inverter.

Parameter r0067 is influenced/determined by the following factors:

- Rated motor current P0305
- Motor overload factor P0640
- Motor protection in dependency of P0610
- r0067 is less than or equal to maximum inverter current r0209
- Inverter protection in dependency of P0290

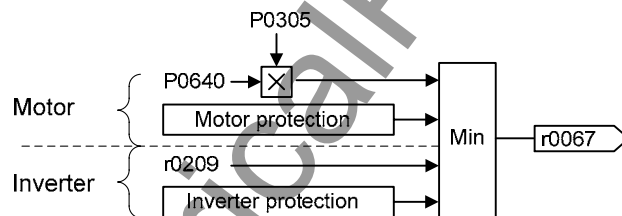

**Note:**

A reduction of r0067 may indicate an inverter overload or a motor overload.

<b>r0071</b>	<b>CO: Max. output voltage</b>	<b>Datatype:</b> Float	<b>Unit:</b> V	<b>Min:</b> -	<b>Level</b>
	<b>P-Group:</b> CONTROL			<b>Def:</b> -	<b>3</b>
				<b>Max:</b> -	

Displays maximum output voltage.

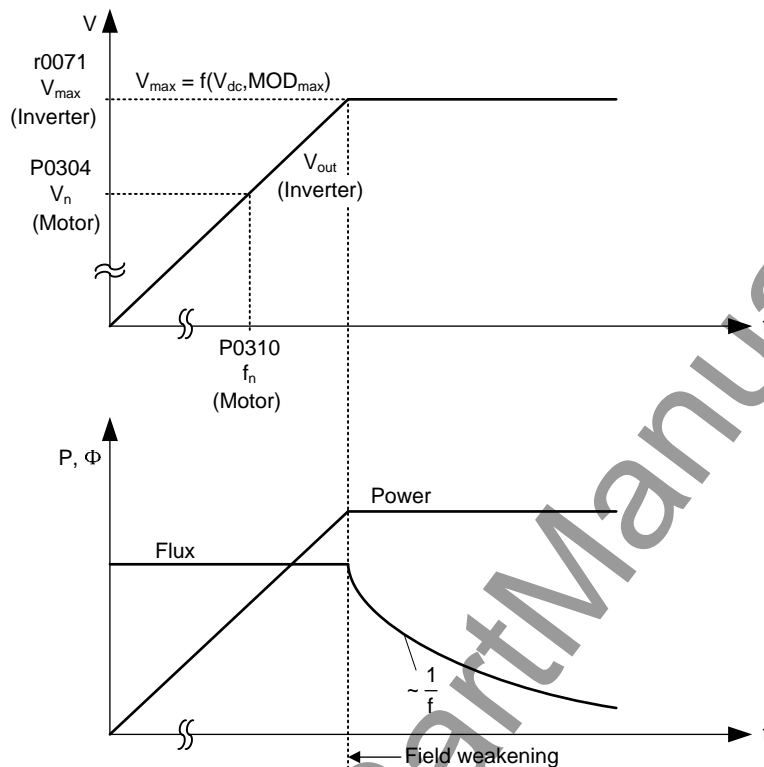

**Dependency:**

- The actual maximum output voltage depends on the actual incoming line supply voltage.
- The maximum possible output voltage r0071 of the drive inverter is determined by the DC link voltage r0026 and the maximum modulation depth P1803 in the gating unit.
- The maximum output voltage r0071 is tracked with the DC link voltage so that the highest possible value is always and automatically achieved.
- The output voltage only reaches the calculated maximum value under steady-state conditions at the rated load.
- In the no-load and partial load ranges, lower output voltages r0025 are obtained.

<b>r0078</b>	<b>CO: Act. current Isq</b>	<b>Datatype:</b> Float	<b>Unit:</b> A	<b>Min:</b> -	<b>Level</b>
	<b>P-Group:</b> CONTROL			<b>Def:</b> -	<b>3</b>
				<b>Max:</b> -	

Displays component of torque generating current.

<b>r0084</b>	<b>CO: Act. air gap flux</b>	<b>Datatype:</b> Float	<b>Unit:</b> %	<b>Min:</b> -	<b>Level</b>
	<b>P-Group:</b> CONTROL			<b>Def:</b> -	<b>4</b>
				<b>Max:</b> -	

Displays air gap flux in [%] relative to the rated motor flux.

<b>r0086</b>	<b>CO: Act. active current</b>	<b>Datatype:</b> Float	<b>Unit:</b> A	<b>Min:</b> -	<b>Level</b>
	<b>P-Group:</b> CONTROL			<b>Def:</b> -	<b>3</b>
				<b>Max:</b> -	

Displays active (real part) of motor current.

**Dependency:**

- Applies when V/f control is selected in P1300 (control mode); otherwise, the display shows the value zero.

### 3.3 Inverter parameters (HW)

<b>P0100</b>	<b>Europe / North America</b>	<b>Min:</b> 0	<b>Level</b>
	<b>CStat:</b> C	<b>Datatype:</b> U16	<b>Def:</b> 0
	<b>P-Group:</b> QUICK	<b>Active:</b> first confirm	<b>QuickComm.:</b> Yes

Determines whether power settings (e.g. nominal rating plate power - P0307) are expressed in [kW] or [hp].

The default settings for the nominal rating plate frequency (P0310) and maximum motor frequency (P1082) are also set automatically here, in addition to reference frequency (P2000).

**Possible Settings:**

- 0 Europe [kW], frequency default 50 Hz
- 1 North America [hp], frequency default 60 Hz
- 2 North America [kW], frequency default 60 Hz

**Dependency:**

Where:

- Stop drive first (i.e. disable all pulses) before you change this parameter.
- P0100 can only be changed when P0010 = 1 (Commissioning mode) via the respective Commissioning interface (e.g. BOP).
- Changing P0100 resets all rated motor parameters as well as other parameters that depend on the rated motor parameters (see P0340 - calculation of motor parameters).

Changing P0100 overwrites the settings of the DIP50/60 switch (location shown in the diagram below):

1. Parameter P0100 has a higher priority than the DIP50/60 switch.
2. However, after the inverter is powered-on again and P0100 < 2, the DIP50/60 setting will take priority and overwrite P0100.
3. The DIP50/60 switch does not have any effect, if P0100 = 2.

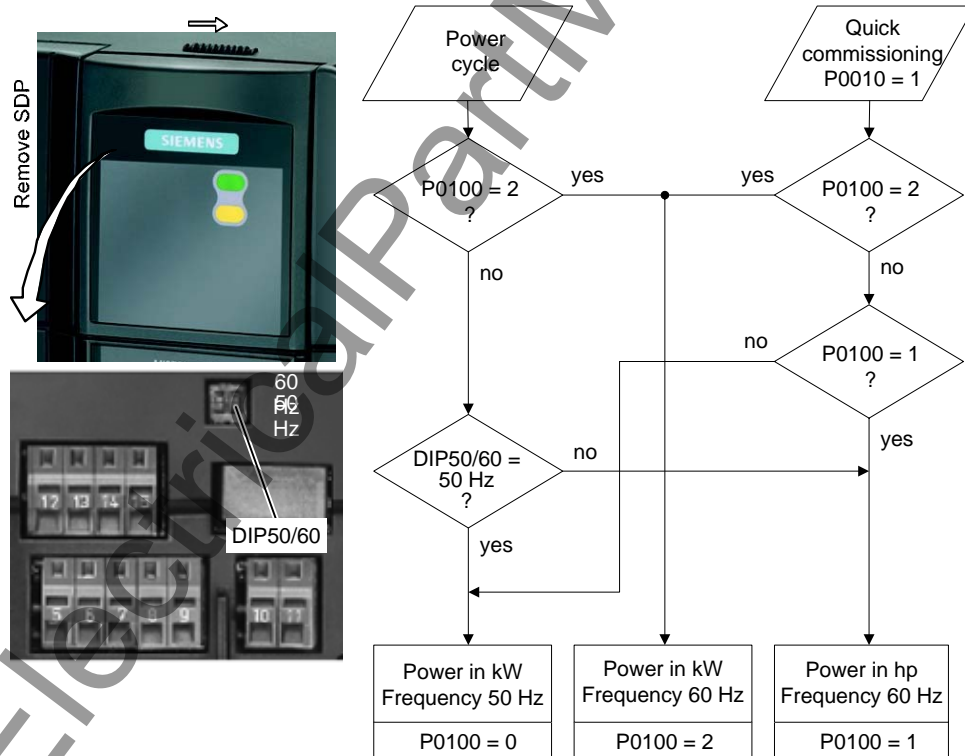

**Notice:**

P0100 setting 2 (==> [kW], frequency default 60 [Hz]) is not overwritten by the setting of DIP switch 2 (see diagram above).

<b>P0199</b>	<b>Equipment system number</b>	<b>Min:</b> 0	<b>Level</b>
	<b>CStat:</b> UT	<b>Datatype:</b> U16	<b>Def:</b> 0
	<b>P-Group:</b> -	<b>Active:</b> first confirm	<b>QuickComm.:</b> No

Equipment system number This parameter has no operation effect.

<b>r0200</b>	<b>Act. power stack code number</b>	<b>Min:</b> -	<b>Level</b> <b>3</b>
	<b>Datatype:</b> U32 <b>Unit:</b> -	<b>Def:</b> -	
	<b>P-Group:</b> INVERTER	<b>Max:</b> -	

Identifies hardware variant as shown in table below.

Code- No.	MM420 MLFB	Input Voltage & Frequency	CT Power kW	Internal Filter	Frame Size
1	6SE6420-2UC11-2AAx	1/3AC200-240V +10% -10% 47-63Hz	0,12	no	A
2	6SE6420-2UC12-5AAx	1/3AC200-240V +10% -10% 47-63Hz	0,25	no	A
3	6SE6420-2UC13-7AAx	1/3AC200-240V +10% -10% 47-63Hz	0,37	no	A
4	6SE6420-2UC15-5AAx	1/3AC200-240V +10% -10% 47-63Hz	0,55	no	A
5	6SE6420-2UC17-5AAx	1/3AC200-240V +10% -10% 47-63Hz	0,75	no	A
6	6SE6420-2UC21-1BAx	1/3AC200-240V +10% -10% 47-63Hz	1,1	no	B
7	6SE6420-2UC21-5BAx	1/3AC200-240V +10% -10% 47-63Hz	1,5	no	B
8	6SE6420-2UC22-2BAx	1/3AC200-240V +10% -10% 47-63Hz	2,2	no	B
9	6SE6420-2UC23-0CAx	1/3AC200-240V +10% -10% 47-63Hz	3	no	C
10	6SE6420-2UC24-0CAx	3AC200-240V +10% -10% 47-63Hz	4	no	C
11	6SE6420-2UC25-5CAx	3AC200-240V +10% -10% 47-63Hz	5,5	no	C
12	6SE6420-2AB11-2AAx	1AC200-240V +10% -10% 47-63Hz	0,12	Cl. A	A
13	6SE6420-2AB12-5AAx	1AC200-240V +10% -10% 47-63Hz	0,25	Cl. A	A
14	6SE6420-2AB13-7AAx	1AC200-240V +10% -10% 47-63Hz	0,37	Cl. A	A
15	6SE6420-2AB15-5AAx	1AC200-240V +10% -10% 47-63Hz	0,55	Cl. A	A
16	6SE6420-2AB17-5AAx	1AC200-240V +10% -10% 47-63Hz	0,75	Cl. A	A
17	6SE6420-2AB21-1BAx	1AC200-240V +10% -10% 47-63Hz	1,1	Cl. A	B
18	6SE6420-2AB21-5BAx	1AC200-240V +10% -10% 47-63Hz	1,5	Cl. A	B
19	6SE6420-2AB22-2BAx	1AC200-240V +10% -10% 47-63Hz	2,2	Cl. A	B
20	6SE6420-2AB23-0CAx	1AC200-240V +10% -10% 47-63Hz	3	Cl. A	C
21	6SE6420-2AB23-1CAx	3AC200-240V +10% -10% 47-63Hz	3	Cl. A	C
22	6SE6420-2AB24-0CAx	3AC200-240V +10% -10% 47-63Hz	4	Cl. A	C
23	6SE6420-2AB25-0CAx	3AC200-240V +10% -10% 47-63Hz	5,5	Cl. A	C
24	6SE6420-2UD13-7AAx	3AC380-480V +10% -10% 47-63Hz	0,37	no	A
25	6SE6420-2UD15-5AAx	3AC380-480V +10% -10% 47-63Hz	0,55	no	A
26	6SE6420-2UD17-5AAx	3AC380-480V +10% -10% 47-63Hz	0,75	no	A
27	6SE6420-2UD21-1AAx	3AC380-480V +10% -10% 47-63Hz	1,1	no	A
28	6SE6420-2UD21-5AAx	3AC380-480V +10% -10% 47-63Hz	1,5	no	A
29	6SE6420-2UD22-2BAx	3AC380-480V +10% -10% 47-63Hz	2,2	no	B
30	6SE6420-2UD23-0BAx	3AC380-480V +10% -10% 47-63Hz	3	no	B
31	6SE6420-2UD24-0BAx	3AC380-480V +10% -10% 47-63Hz	4	no	B
32	6SE6420-2UD25-5CAx	3AC380-480V +10% -10% 47-63Hz	5,5	no	C
33	6SE6420-2UD27-5CAx	3AC380-480V +10% -10% 47-63Hz	7,5	no	C
34	6SE6420-2UD31-1CAx	3AC380-480V +10% -10% 47-63Hz	11	no	C
35	6SE6420-2AD22-2BAx	3AC380-480V +10% -10% 47-63Hz	2,2	Cl. A	B
36	6SE6420-2AD23-0BAx	3AC380-480V +10% -10% 47-63Hz	3	Cl. A	B
37	6SE6420-2AD24-0BAx	3AC380-480V +10% -10% 47-63Hz	4	Cl. A	B
38	6SE6420-2AD25-5CAx	3AC380-480V +10% -10% 47-63Hz	5,5	Cl. A	C
39	6SE6420-2AD27-5CAx	3AC380-480V +10% -10% 47-63Hz	7,5	Cl. A	C
40	6SE6420-2AD31-1CAx	3AC380-480V +10% -10% 47-63Hz	11	Cl. A	C

**Notice:**

Parameter r0200 = 0 indicates that no power stack has been identified.

<b>P0201</b>	<b>Power stack code number</b>	<b>Min:</b> 0	<b>Level</b> <b>3</b>
	<b>CStat:</b> C <b>Datatype:</b> U16 <b>Unit:</b> -	<b>Def:</b> 0	
	<b>P-Group:</b> INVERTER <b>Active:</b> first confirm <b>QuickComm.:</b> No	<b>Max:</b> 65535	

Confirms actual power stack identified.

<b>r0203</b>	<b>Act. inverter type</b>	<b>Datatype:</b> U16	<b>Unit:</b> -	<b>Min:</b> - <b>Def:</b> - <b>Max:</b> -	<b>Level</b> <b>3</b>
	<b>P-Group:</b> INVERTER				
	Type number of actual inverter identified.				
	<b>Possible Settings:</b>				
	1 MICROMASTER 420				
	2 MICROMASTER 440				
	3 MICRO- / COMBIMASTER 411				
	4 MICROMASTER 410				
	5 Reserved				
	6 MICROMASTER 440 PX				
	7 MICROMASTER 430				
<b>r0204</b>	<b>Power stack features</b>	<b>Datatype:</b> U32	<b>Unit:</b> -	<b>Min:</b> - <b>Def:</b> - <b>Max:</b> -	<b>Level</b> <b>3</b>
	<b>P-Group:</b> INVERTER				
	Displays hardware features of power stack.				
	<b>Bitfields:</b>				
	Bit00	DC input voltage	0 NO	1 YES	
	Bit01	RFI filter	0 NO	1 YES	
	<b>Note:</b>				
	Parameter r0204 = 0 indicates that no power stack has been identified.				
<b>r0206</b>	<b>Rated inverter power [kW] / [hp]</b>	<b>Datatype:</b> Float	<b>Unit:</b> -	<b>Min:</b> - <b>Def:</b> - <b>Max:</b> -	<b>Level</b> <b>2</b>
	<b>P-Group:</b> INVERTER				
	Displays nominal rated motor power from inverter.				
	<b>Dependency:</b>				
	Value is displayed in [kW] or [hp] depending on setting for P0100 (operation for Europe / North America).				
	$r0206 [hp] = 0.75 \cdot r0206 [kW]$				
<b>r0207[2]</b>	<b>Rated inverter current</b>	<b>Datatype:</b> Float	<b>Unit:</b> A	<b>Min:</b> - <b>Def:</b> - <b>Max:</b> -	<b>Level</b> <b>2</b>
	<b>P-Group:</b> INVERTER				
	Displays rated output current of inverter.				
	r0207[0] : Rated inverter current				
	r0207[1] : Rated motor current				
<b>r0208</b>	<b>Rated inverter voltage</b>	<b>Datatype:</b> U32	<b>Unit:</b> V	<b>Min:</b> - <b>Def:</b> - <b>Max:</b> -	<b>Level</b> <b>2</b>
	<b>P-Group:</b> INVERTER				
	Displays nominal AC supply voltage of inverter.				
	<b>Value:</b>				
	r0208 = 230 : 200 - 240 V +/- 10 %				
	r0208 = 400 : 380 - 480 V +/- 10 %				
	r0208 = 575 : 500 - 600 V +/- 10 %				
<b>r0209</b>	<b>Maximum inverter current</b>	<b>Datatype:</b> Float	<b>Unit:</b> A	<b>Min:</b> - <b>Def:</b> - <b>Max:</b> -	<b>Level</b> <b>2</b>
	<b>P-Group:</b> INVERTER				
	Displays maximum output current of inverter.				
	<b>Dependency:</b>				
	Parameter r0209 depends on the derating which is affected by pulse frequency P1800, ambient temperature and altitude. The data of deration is given in the Operating Instruction.				

<b>P0210</b>	<b>Supply voltage</b>			<b>Min:</b> 0	Level <b>3</b>
	<b>CStat:</b> CT	<b>Datatype:</b> U16	<b>Unit:</b> V	<b>Def:</b> 230	
	<b>P-Group:</b> INVERTER	<b>Active:</b> Immediately	<b>QuickComm.:</b> No	<b>Max:</b> 1000	

Parameter P0210 defines the supply voltage.

Its default value depends upon the type of inverter. If P0210 does not correspond to the supply voltage, then it must be modified.

When P0210 has been modified, the following thresholds are changed:

Vdc\_max switch-on level =  $1.15 \cdot \sqrt{2} \cdot P0210$

Compound braking switch-on level =  $1.13 \cdot \sqrt{2} \cdot P0210$

**Dependency:**

Optimizes Vdc controller, which extends the ramp-down time if regenerative energy from motor would otherwise cause DC link overvoltage trips.

Reducing the value enables controller to cut in earlier and reduce the risk of overvoltage.

Set P1254 ("Auto detect Vdc switch-on levels") = 0. Cut-in levels for Vdc-controller and compound braking are then derived directly from P0210 (supply voltage).

**Note:**

- If mains voltage is higher than value entered, automatic deactivation of the Vdc controller may occur to avoid acceleration of the motor. An alarm will be issued in this case (A0910).
- Default value is depending on inverter type and its rating data.

<b>r0231[2]</b>	<b>Max. cable length</b>			<b>Min:</b> -	Level <b>3</b>
	<b>P-Group:</b> INVERTER	<b>Datatype:</b> U16	<b>Unit:</b> m	<b>Def:</b> -	
				<b>Max:</b> -	

Indexed parameter to display maximum allowable cable length between inverter and motor.

**Index:**

r0231[0] : Max. allowed unscreened cable length

r0231[1] : Max. allowed screened cable length

**Notice:**

For full EMC compliance, the screened cable must not exceed 25 m in length when an EMC filter is fitted.

<b>P0290</b>	<b>Inverter overload reaction</b>			<b>Min:</b> 0	Level <b>3</b>
	<b>CStat:</b> CT	<b>Datatype:</b> U16	<b>Unit:</b> -	<b>Def:</b> 2	
	<b>P-Group:</b> INVERTER	<b>Active:</b> first confirm	<b>QuickComm.:</b> No	<b>Max:</b> 3	

Selects reaction of inverter to an internal over-temperature.

Following physical values influence the inverter overload protection (see diagram):

- heat sink temperature
- inverter I<sup>2</sup>t

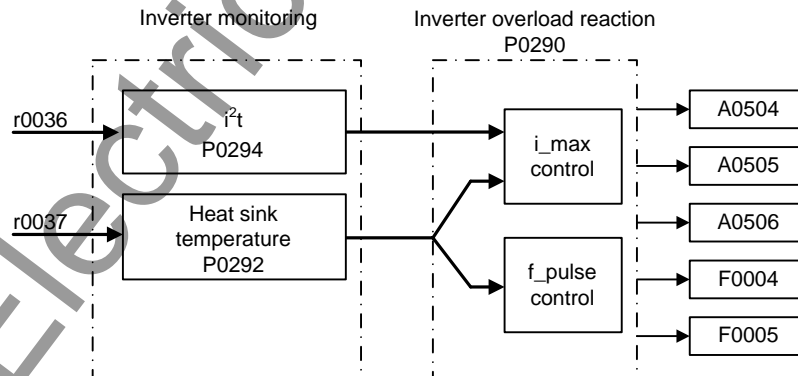

**Possible Settings:**

- 0 Reduce output frequency
- 1 Trip (F0004)
- 2 Reduce pulse frequency and output frequency
- 3 Reduce pulse frequency then trip (F0004)

**Notice:**

P0290 = 0:  
Reduction of output frequency is only effective if the load is also reduced. This is for example valid for variable torque applications with a quadratic torque characteristic as pumps or fans.

A trip will always result, if the action taken does not sufficiently reduce internal temperature.

The pulse frequency P1800 is reduced only if higher than 2 kHz. The actual pulse frequency is displayed in parameter r1801.

<b>P0291</b>	<b>Inverter protection</b>	<b>Min:</b> 0	<b>Level</b> <b>4</b>	
	<b>CStat:</b> CT	<b>Datatype:</b> U16		<b>Def:</b> 1
	<b>P-Group:</b> INVERTER	<b>Active:</b> Immediately		<b>QuickComm.:</b> No

Bit 00 for enabling/disabling automatic pulse frequency reduction at output frequencies below 2 Hz. The benefit is to reduce the noises at frequencies below 2 Hz.

**Bitfields:**

Bit00	Pulse frequency reduced below 2Hz	0	NO	1	YES
Bit03	Enable fan	0	NO	1	YES

**Caution:**

P0291 Bit 00 = 0:

No automatic pulse frequency is applied at frequencies below 2 Hz. There is a risk of damage to the inverter if DC-braking or greater boost are used respectively.

**Details:**

See P0290 (inverter overload reaction)

<b>P0292</b>	<b>Inverter temperature warning</b>	<b>Min:</b> 0	<b>Level</b> <b>3</b>	
	<b>CStat:</b> CUT	<b>Datatype:</b> U16		<b>Def:</b> 15
	<b>P-Group:</b> INVERTER	<b>Active:</b> first confirm		<b>QuickComm.:</b> No

Defines the temperature difference (in °C) between the Overtemperature trip threshold and the warning threshold of the inverter. The trip threshold is stored internally by the inverter and cannot be changed by the user.

Temperature warning threshold of inverter  $T_{warn}$  :

$$T_{warn} = T_{trip} - P0292 = 110 \text{ °C} - P0292$$

If the actual inverter temperature (r0037) exceeds the corresponding threshold, a warning A0504, if the temperature still increases then a fault F0004 will be displayed.

<b>P0294</b>	<b>Inverter I2t overload warning</b>	<b>Min:</b> 10.0	<b>Level</b> <b>4</b>	
	<b>CStat:</b> CUT	<b>Datatype:</b> Float		<b>Def:</b> 95.0
	<b>P-Group:</b> INVERTER	<b>Active:</b> first confirm		<b>QuickComm.:</b> No

Defines the [%] value at which alarm A0505 (inverter I2t) is generated.

Inverter I2t calculation is used to determine a maximum tolerable period for inverter overload. The I2t calculation value is deemed = 100 % when this maximum tolerable period is reached.

**Dependency:**

That the output current of the inverter has been reduced and that the value of I2t does not exceed 100%.

**Note:**

P0294 = 100 % corresponds to stationary nominal load.

<b>P0295</b>	<b>Inverter fan off delay time</b>	<b>Min:</b> 0	<b>Level</b> <b>3</b>	
	<b>CStat:</b> CUT	<b>Datatype:</b> U16		<b>Def:</b> 0
	<b>P-Group:</b> TERMINAL	<b>Active:</b> first confirm		<b>QuickComm.:</b> No

Defines inverter fan switch off delay time in seconds after drive has stopped.

**Note:**

Setting to 0, inverter fan will switch off when the drive stops, that is no delay.

### 3.4 Motor parameters

<b>P0300</b>	<b>Select motor type</b>	<b>Datatype:</b> U16	<b>Unit:</b> -	<b>Min:</b> 1	Level <b>2</b>
	<b>CStat:</b> C	<b>Active:</b> first confirm	<b>QuickComm.:</b> Yes	<b>Def:</b> 1	
	<b>P-Group:</b> MOTOR			<b>Max:</b> 2	

Selects motor type.

This parameter is required during commissioning to select motor type and optimize inverter performance. Most motors are asynchronous; if in doubt, use the formula below.

$$x = P0310 \cdot \frac{60}{P0311}$$

$x = 1, 2, \dots, n$  : Synchronous motor

$x \neq 1, 2, \dots, n$  : Asynchronous motor

If the result is a whole number, the motor is synchronous.

**Possible Settings:**

- 1 Asynchronous motor
- 2 Synchronous motor

**Dependency:**

Changeable only when P0010 = 1 (quick commissioning).

If synchronous motor is selected, the following functions are not available:

- P0308 Power factor
- P0309 Motor efficiency
- P0346 Magnetization time
- P0347 Demagnetization time
- P1335 Slip compensation
- P1336 Slip limit
- P0320 Motor magnetizing current
- P0330 Rated motor slip
- P0331 Rated magnetization current
- P0332 Rated power factor
- P0384 Rotor time constant
- P1200, P1202, P1203 Flying start
- P1230, P1232, P1233 DC braking

<b>P0304</b>	<b>Rated motor voltage</b>	<b>Datatype:</b> U16	<b>Unit:</b> V	<b>Min:</b> 10	<b>Level</b> <b>1</b>
	<b>CStat:</b> C	<b>Active:</b> first confirm	<b>QuickComm.:</b> Yes	<b>Def:</b> 230	
	<b>P-Group:</b> MOTOR			<b>Max:</b> 2000	

Nominal motor voltage [V] from rating plate. Following diagram shows a typical rating plate with the locations of the relevant motor data.

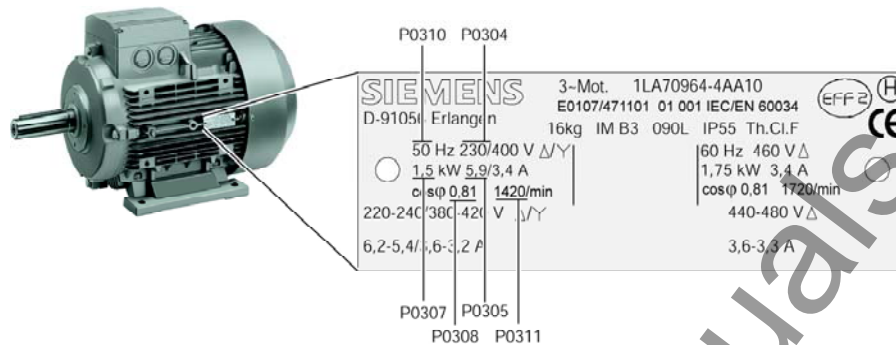

Line supply voltage	1 AC 110 V *)	1 AC 230 V	3 AC 230 V	3 AC 400 V	3 AC 500 V
MICROMASTER 410	X	X	-	-	-
MICROMASTER 411	-	-	-	X	-
MICROMASTER 420	-	X	X	X	-
MICROMASTER 430	-	-	-	X	-
MICROMASTER 440	-	X	X	X	X

\*) Line supply voltage 1-ph. 110 V AC is stepped-up --> frequency inverter output voltage 3-ph. 230 V AC

**Dependency:**

- Changeable only when P0010 = 1 (quick commissioning).
- Default value is depending on inverter type and its rating data.



**Caution:**

The input of rating plate data must correspond with the wiring of the motor (star / delta). This means, if delta wiring is used for the motor, delta rating plate data has to be entered.

**IEC Motor**

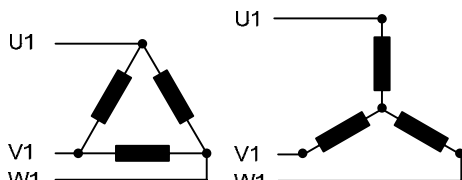
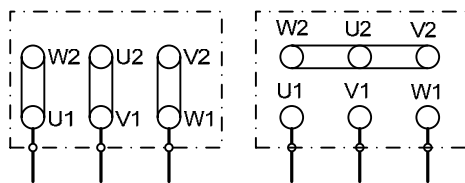

Delta connection

Star connection

e.g.: Volts 230 V (Delta connection) / 400 V (Star connection)

**NEMA Motor**

Volts	U	V	W	Connected together	Connection
low	T <sub>1</sub> -T <sub>7</sub>	T <sub>2</sub> -T <sub>8</sub>	T <sub>3</sub> -T <sub>9</sub>	T <sub>4</sub> -T <sub>5</sub> -T <sub>6</sub>	Y Y
high	T <sub>1</sub>	T <sub>2</sub>	T <sub>3</sub>	T <sub>1</sub> -T <sub>7</sub> T <sub>2</sub> -T <sub>8</sub> T <sub>3</sub> -T <sub>9</sub>	Y

e.g.: Volts 230 V YY (low) / 460 V Y (high)

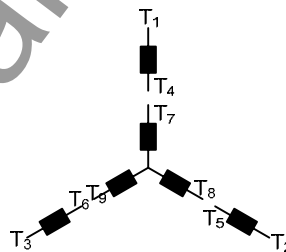

Volts	U	V	W	Connected together	Connection
low	T <sub>1</sub> -T <sub>6</sub> -T <sub>7</sub>	T <sub>2</sub> -T <sub>4</sub> -T <sub>8</sub>	T <sub>3</sub> -T <sub>5</sub> -T <sub>9</sub>	-	Δ Δ
high	T <sub>1</sub>	T <sub>2</sub>	T <sub>3</sub>	T <sub>4</sub> -T <sub>7</sub> T <sub>5</sub> -T <sub>8</sub> T <sub>6</sub> -T <sub>9</sub>	Δ

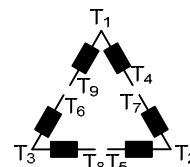

<b>P0305</b>	<b>Rated motor current</b>	<b>Datatype:</b> Float	<b>Unit:</b> A	<b>Min:</b> 0.01	<b>Level</b> <b>1</b>
	<b>CStat:</b> C	<b>Active:</b> first confirm	<b>QuickComm.:</b> Yes	<b>Def:</b> 3.25	
	<b>P-Group:</b> MOTOR			<b>Max:</b> 10000.00	

Nominal motor current [A] from rating plate - see diagram in P0304.

**Dependency:**

- Changeable only when P0010 = 1 (quick commissioning).
- Default value is depending on inverter type and its rating data.
- Depends also on P0320 (motor magnetization current).

**Note:**

The maximum value of P0305 depends on the maximum inverter current r0209 and the motor type:

Asynchronous motor : P0305<sub>max, asyn</sub> = r0209

Synchronous motor : P0305<sub>max, syn</sub> = 2 · r0209

It is recommended that the ratio of P0305 (rated motor current) and r0207 (rated inverter current) should not be lower than:

$$V/f: \frac{1}{8} \leq \frac{P0305}{r0207}$$

The absolute minimum value of P0305 is defined as 1/32 times inverter rated current (r0207).

<b>P0307</b>	<b>Rated motor power</b>			<b>Min:</b> 0.01	Level <b>1</b>
	<b>CStat:</b> C	<b>Datatype:</b> Float	<b>Unit:</b> -	<b>Def:</b> 0.12	
	<b>P-Group:</b> MOTOR	<b>Active:</b> first confirm	<b>QuickComm.:</b> Yes	<b>Max:</b> 2000.00	

Nominal motor power [kW/hp] from rating plate.

**Dependency:**

- If P0100 = 1, values will be in [hp] - see diagram P0304 (rating plate).
- Changeable only when P0010 = 1 (quick commissioning).
- Default value is depending on inverter type and its rating data.

<b>P0308</b>	<b>Rated motor cosPhi</b>			<b>Min:</b> 0.000	Level <b>1</b>
	<b>CStat:</b> C	<b>Datatype:</b> Float	<b>Unit:</b> -	<b>Def:</b> 0.000	
	<b>P-Group:</b> MOTOR	<b>Active:</b> first confirm	<b>QuickComm.:</b> Yes	<b>Max:</b> 1.000	

Nominal motor power factor (cosPhi) from rating plate - see diagram P0304.

**Dependency:**

- Changeable only when P0010 = 1 (quick commissioning).
- Visible only when P0100 = 0 or 2, (motor power entered in [kW]).
- Default value is depending on inverter type and its rating data.

- Setting 0 causes internal calculation of value. Calculated value see r0332.

<b>P0309</b>	<b>Rated motor efficiency</b>			<b>Min:</b> 0.0	Level <b>1</b>
	<b>CStat:</b> C	<b>Datatype:</b> Float	<b>Unit:</b> %	<b>Def:</b> 0.0	
	<b>P-Group:</b> MOTOR	<b>Active:</b> first confirm	<b>QuickComm.:</b> Yes	<b>Max:</b> 99.9	

Nominal motor efficiency in [%] from rating plate.

**Dependency:**

- Changeable only when P0010 = 1 (quick commissioning).
- Visible only when P0100 = 1, (i.e. motor power entered in [hp]).
- Default value is depending on inverter type and its rating data.

- Setting 0 causes internal calculation of value. Calculated value see r0332.

**Note:**

P0309 = 100 % corresponds to superconducting.

**Details:**

See diagram in P0304 (rating plate).

<b>P0310</b>	<b>Rated motor frequency</b>			<b>Min:</b> 12.00	Level <b>1</b>
	<b>CStat:</b> C	<b>Datatype:</b> Float	<b>Unit:</b> Hz	<b>Def:</b> 50.00	
	<b>P-Group:</b> MOTOR	<b>Active:</b> first confirm	<b>QuickComm.:</b> Yes	<b>Max:</b> 650.00	

Nominal motor frequency [Hz] from rating plate.

**Dependency:**

- Changeable only when P0010 = 1 (quick commissioning).
- Pole pair number recalculated automatically if parameter is changed.

**Details:**

See diagram in P0304 (rating plate)

<b>P0311</b>	<b>Rated motor speed</b>			<b>Min:</b> 0	Level <b>1</b>
	<b>CStat:</b> C	<b>Datatype:</b> U16	<b>Unit:</b> 1/min	<b>Def:</b> 0	
	<b>P-Group:</b> MOTOR	<b>Active:</b> first confirm	<b>QuickComm.:</b> Yes	<b>Max:</b> 40000	

Nominal motor speed [rpm] from rating plate.

**Dependency:**

- Changeable only when P0010 = 1 (quick commissioning).
- Setting 0 causes internal calculation of value.
- Slip compensation in V/f control requires rated motor speed for correct operation.
- Pole pair number recalculated automatically if parameter is changed.
- Default value is depending on inverter type and its rating data.

- Required for vector control and V/f control with speed controller.

**Details:**

See diagram in P0304 (rating plate)

<b>r0313</b>	<b>Motor pole pairs</b>	<b>Datatype:</b> U16	<b>Unit:</b> -	<b>Min:</b> - <b>Def:</b> - <b>Max:</b> -	Level <b>3</b>
	<b>P-Group:</b> MOTOR				

Displays number of motor pole pairs that the inverter is currently using for internal calculations.

**Value:**

r0313 = 1 : 2-pole motor  
r0313 = 2 : 4-pole motor  
etc.

**Dependency:**

Recalculated automatically when P0310 (rated motor frequency) or P0311 (rated motor speed) is changed.

$$r0313 = 60 \cdot \frac{P0310}{P0311}$$

<b>P0320</b>	<b>Motor magnetizing current</b>	<b>Datatype:</b> Float	<b>Unit:</b> %	<b>Min:</b> 0.0 <b>Def:</b> 0.0 <b>Max:</b> 99.0	Level <b>3</b>
	<b>CStat:</b> CT <b>P-Group:</b> MOTOR	<b>Active:</b> Immediately	<b>QuickComm.:</b> Yes		

Defines motor magnetization current in [%] relative to P0305 (rated motor current).

**Dependency:**

Setting P0320 = 0: causes calculation by  
- P0340 = 1 (data entered from rating plate) or by  
- P3900 = 1 - 3 (end of quick commissioning). The calculated value is displayed in parameter r0331.

<b>r0330</b>	<b>Rated motor slip</b>	<b>Datatype:</b> Float	<b>Unit:</b> %	<b>Min:</b> - <b>Def:</b> - <b>Max:</b> -	Level <b>3</b>
	<b>P-Group:</b> MOTOR				

Displays nominal motor slip in [%] relative to P0310 (rated motor frequency) and P0311 (rated motor speed).

$$r0330[\%] = \frac{P0310 - \frac{P0311}{60} \cdot r0313}{P0310} \cdot 100\%$$

<b>r0331</b>	<b>Rated magnetization current</b>	<b>Datatype:</b> Float	<b>Unit:</b> A	<b>Min:</b> - <b>Def:</b> - <b>Max:</b> -	Level <b>3</b>
	<b>P-Group:</b> MOTOR				

Displays calculated magnetizing current of motor in [A].

<b>r0332</b>	<b>Rated power factor</b>	<b>Datatype:</b> Float	<b>Unit:</b> -	<b>Min:</b> - <b>Def:</b> - <b>Max:</b> -	Level <b>3</b>
	<b>P-Group:</b> MOTOR				

Displays power factor for motor

**Dependency:**

Value is calculated internally if P0308 (rated motor cosPhi) set to 0; otherwise, value entered in P0308 is displayed.

<b>P0335</b>	<b>Motor cooling</b>	<b>Datatype:</b> U16	<b>Unit:</b> -	<b>Min:</b> 0 <b>Def:</b> 0 <b>Max:</b> 1	Level <b>2</b>
	<b>CStat:</b> CT <b>P-Group:</b> MOTOR	<b>Active:</b> first confirm	<b>QuickComm.:</b> Yes		

Selects motor cooling system used.

**Possible Settings:**

- 0 Self-cooled: Using shaft mounted fan attached to motor
- 1 Force-cooled: Using separately powered cooling fan

**Caution:**

The following combination of parameter setting should not be combined:

- P0610 = 1 and P0335 = 0 or 2 :  
When P0335 = 0 or 2 the inverter cools the motor using a shaft mounted fan. If this is used in conjunction with P0610 the cooling of the motor will be inefficient.  
In essence, if the i2t calculation reduces the output frequency, then the shaft mounted fan will also reduce its cooling effect, the motor will then eventually overheat and trip.
- Exception:  
Applications with variable torque the reduction of max. current leads automatically to a reduction of the load / output current.

**Notice:**

Motors of series 1LA1 and 1LA8 have an internal fan. This internal motor fan must not be confused with the fan at the end of the motor shaft.

<b>P0340</b>	<b>Calculation of motor parameters</b>				<b>Min:</b> 0	<b>Level</b> <b>2</b>
	<b>CStat:</b> CT	<b>Datatype:</b> U16	<b>Unit:</b> -	<b>Def:</b> 0		
	<b>P-Group:</b> MOTOR	<b>Active:</b> first confirm	<b>QuickComm.:</b> No	<b>Max:</b> 1		

Calculates various motor parameters (see table below). This parameter is required during commissioning to optimize inverter performance.

**Possible Settings:**

- 0 No calculation
- 1 Complete parameterization

**Note:**

	P0340 = 1
P0344 Motor weight	x
P0346 Magnetization time	x
P0347 Demagnetization time	x
P0350 Stator resistance (line-to-line)	x
P0611 Motor I2t time constant	x
P1253 Vdc-controller output limitation	x
P1316 Boost end frequency	x
P2000 Reference frequency	x
P2002 Reference current	x

<b>P0344</b>	<b>Motor weight</b>				<b>Min:</b> 1.0	<b>Level</b> <b>3</b>
	<b>CStat:</b> CUT	<b>Datatype:</b> Float	<b>Unit:</b> kg	<b>Def:</b> 9.4		
	<b>P-Group:</b> MOTOR	<b>Active:</b> Immediately	<b>QuickComm.:</b> No	<b>Max:</b> 6500.0		

Specifies motor weight [kg].

**Note:**

- This value is used in the motor thermal model.
- It is normally calculated automatically from P0340 (motor parameters) but can also be entered manually.
- Default value is depending on inverter type and its rating data.

<b>P0346</b>	<b>Magnetization time</b>				<b>Min:</b> 0.000	<b>Level</b> <b>3</b>
	<b>CStat:</b> CUT	<b>Datatype:</b> Float	<b>Unit:</b> s	<b>Def:</b> 1.000		
	<b>P-Group:</b> MOTOR	<b>Active:</b> Immediately	<b>QuickComm.:</b> No	<b>Max:</b> 20.000		

Sets magnetization time [s], i.e. waiting time between pulse enable and start of ramp-up. Motor magnetization builds up during this time.

Magnetization time is normally calculated automatically from the motor data and corresponds to the rotor time constant (r0384).

**Note:**

- If boost settings are higher than 100 %, magnetization time may be reduced.
- Default value is depending on inverter type and its rating data.
- An excessive reduction of this time can result in insufficient motor magnetization.

<b>P0347</b>	<b>Demagnetization time</b>	<b>Min:</b> 0.000	<b>Level</b>
	<b>CStat:</b> CUT	<b>Datatype:</b> Float	<b>Unit:</b> s
	<b>P-Group:</b> MOTOR	<b>Active:</b> Immediately	<b>QuickComm.:</b> No
		<b>Def:</b> 1.000	<b>3</b>
		<b>Max:</b> 20.000	

Defines the de-magnetization time for the connected induction motor.

The de-magnetization time is the time that must expire between powering-down the drive (OFF2 or a drive inverter fault/error) and powering-up again. The drive inverter is prevented from being powered-up again within this time interval. The flux in the induction motor is reduced to a low value during this de-magnetization time.

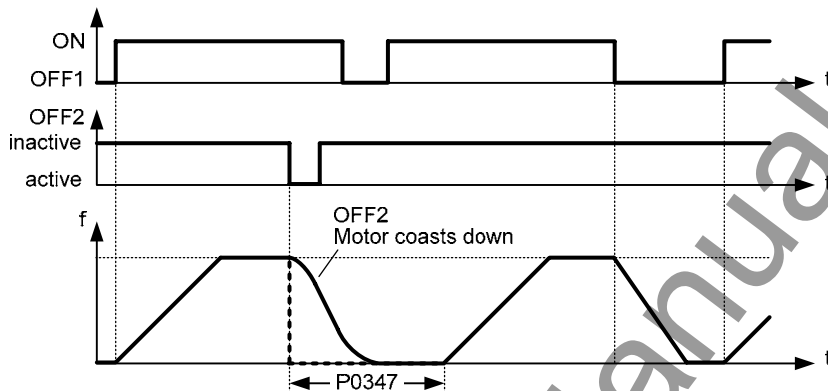

**Note:**

- The de-magnetization time is approximately 250% of the rotor time constant (r0384) in seconds.
- The pre-assignment (default value) depends on the drive inverter type and its rated/nominal values.
- It is not active after a normal ramp-down - i.e. after OFF1 or OFF3.
- If this time is excessively shortened, then the drive inverter will be tripped (shut down) due to an overcurrent condition.
- If a synchronous motor is connected, the de-magnetization time should be set to 0.

<b>P0350</b>	<b>Stator resistance (line-to-line)</b>	<b>Min:</b> 0.00001	<b>Level</b>
	<b>CStat:</b> CUT	<b>Datatype:</b> Float	<b>Unit:</b> Ohm
	<b>P-Group:</b> MOTOR	<b>Active:</b> Immediately	<b>QuickComm.:</b> No
		<b>Def:</b> 4.00000	<b>3</b>
		<b>Max:</b> 2000.00000	

Stator resistance value in [Ohms] for connected motor (from line-to-line). The parameter value includes the cable resistance.

$$P0350 = 2 \cdot (R_{Cable} + R_S)$$

There are three ways to determine the value for this parameter:

1. Calculate using
  - P0340 = 1 (data entered from rating plate) or
  - P0010 = 1, P3900 = 1,2 or 3 (end of quick commissioning).
2. Measure using P1910 = 1 (motor data identification - value for stator resistance is overwritten).
3. Measure manually using an Ohmmeter.

**Note:**

- Since measured line-to-line, this value may appear to be higher (up to 2 times higher) than expected.
- The value entered in P0350 (stator resistance) is the one obtained by the method last used.
- Default value is depending on inverter type and its rating data.

<b>r0370</b>	<b>Stator resistance [%]</b>	<b>Min:</b> -	<b>Level</b>
		<b>Datatype:</b> Float	<b>Unit:</b> %
	<b>P-Group:</b> MOTOR		<b>QuickComm.:</b> No
		<b>Def:</b> -	<b>4</b>
		<b>Max:</b> -	

Displays standardized stator resistance of motor equivalent circuit (phase value) in [%] as a function of the actual stator winding temperature.

**Note:**

Rated motor impedance:

$$Z_N = \frac{V_{ph}}{I_{ph}} = \frac{V_N}{\sqrt{3} \cdot I_N} = \frac{P0304}{\sqrt{3} \cdot P0305} \Leftrightarrow 100 \%$$

<b>r0372</b>	<b>Cable resistance [%]</b>	<b>Datatype:</b> Float	<b>Unit:</b> %	<b>Min:</b> - <b>Def:</b> - <b>Max:</b> -	<b>Level</b> <b>4</b>
	<b>P-Group:</b> MOTOR				
Displays standardized cable resistance of motor equivalent circuit (phase value) in [%]. It is estimated to be 20 % of the stator resistance.					
<b>Note:</b>					
Rated motor impedance:					
$Z_N = \frac{V_{ph}}{I_{ph}} = \frac{V_N}{\sqrt{3} \cdot I_N} = \frac{P0304}{\sqrt{3} \cdot P0305} \Leftrightarrow 100 \%$					
<b>r0373</b>	<b>Rated stator resistance [%]</b>	<b>Datatype:</b> Float	<b>Unit:</b> %	<b>Min:</b> - <b>Def:</b> - <b>Max:</b> -	<b>Level</b> <b>4</b>
	<b>P-Group:</b> MOTOR				
Displays the nominal stator resistance of the motor equivalent circuit diagram (phase value) as a [%] at the ambient temperature + temperature rise of the stator winding.					
<b>Note:</b>					
Rated motor impedance:					
$Z_N = \frac{V_{ph}}{I_{ph}} = \frac{V_N}{\sqrt{3} \cdot I_N} = \frac{P0304}{\sqrt{3} \cdot P0305} \Leftrightarrow 100 \%$					
<b>r0374</b>	<b>Rotor resistance [%]</b>	<b>Datatype:</b> Float	<b>Unit:</b> %	<b>Min:</b> - <b>Def:</b> - <b>Max:</b> -	<b>Level</b> <b>4</b>
	<b>P-Group:</b> MOTOR				
Displays the rotor resistance of the motor equivalent circuit diagram (phase value) as a [%] at the ambient temperature (in the cold state).					
<b>Note:</b>					
Rated motor impedance:					
$Z_N = \frac{V_{ph}}{I_{ph}} = \frac{V_N}{\sqrt{3} \cdot I_N} = \frac{P0304}{\sqrt{3} \cdot P0305} \Leftrightarrow 100 \%$					
<b>r0376</b>	<b>Rated rotor resistance [%]</b>	<b>Datatype:</b> Float	<b>Unit:</b> %	<b>Min:</b> - <b>Def:</b> - <b>Max:</b> -	<b>Level</b> <b>4</b>
	<b>P-Group:</b> MOTOR				
Displays the nominal rotor resistance of the motor equivalent circuit diagram (phase value) as a [%] at the ambient temperature + temperature rise of the rotor winding.					
<b>Note:</b>					
Rated motor impedance:					
$Z_N = \frac{V_{ph}}{I_{ph}} = \frac{V_N}{\sqrt{3} \cdot I_N} = \frac{P0304}{\sqrt{3} \cdot P0305} \Leftrightarrow 100 \%$					
<b>r0377</b>	<b>Total leakage reactance [%]</b>	<b>Datatype:</b> Float	<b>Unit:</b> %	<b>Min:</b> - <b>Def:</b> - <b>Max:</b> -	<b>Level</b> <b>4</b>
	<b>P-Group:</b> MOTOR				
Displays standardized total leakage reactance of the motor equivalent circuit (phase value) in [%].					
<b>Note:</b>					
Rated motor impedance:					
$Z_N = \frac{V_{ph}}{I_{ph}} = \frac{V_N}{\sqrt{3} \cdot I_N} = \frac{P0304}{\sqrt{3} \cdot P0305} \Leftrightarrow 100 \%$					
<b>r0382</b>	<b>Main reactance [%]</b>	<b>Datatype:</b> Float	<b>Unit:</b> %	<b>Min:</b> - <b>Def:</b> - <b>Max:</b> -	<b>Level</b> <b>4</b>
	<b>P-Group:</b> MOTOR				
Displays standardized main reactance of the motor equivalent circuit (phase value) in [%].					
<b>Note:</b>					
Rated motor impedance:					
$Z_N = \frac{V_{ph}}{I_{ph}} = \frac{V_N}{\sqrt{3} \cdot I_N} = \frac{P0304}{\sqrt{3} \cdot P0305} \Leftrightarrow 100 \%$					
<b>r0384</b>	<b>Rotor time constant</b>	<b>Datatype:</b> Float	<b>Unit:</b> ms	<b>Min:</b> - <b>Def:</b> - <b>Max:</b> -	<b>Level</b> <b>3</b>
	<b>P-Group:</b> MOTOR				
Displays calculated rotor time constant [ms].					

<b>r0386</b>	<b>Total leakage time constant</b>	<b>Datatype:</b> Float	<b>Unit:</b> ms	<b>Min:</b> - <b>Def:</b> - <b>Max:</b> -	Level <b>4</b>
	<b>P-Group:</b> MOTOR				

Displays total leakage time constant of motor.

<b>r0395</b>	<b>CO: Total stator resistance [%]</b>	<b>Datatype:</b> Float	<b>Unit:</b> %	<b>Min:</b> - <b>Def:</b> - <b>Max:</b> -	Level <b>3</b>
	<b>P-Group:</b> MOTOR				

Displays the actual stator resistance (combined stator/cable resistance) of the motor as a [%] as a function of the actual stator winding temperature.

**Note:**

Rated motor impedance:

$$Z_N = \frac{V_{ph}}{I_{ph}} = \frac{V_N}{\sqrt{3} \cdot I_N} = \frac{P0304}{\sqrt{3} \cdot P0305} \Leftrightarrow 100 \%$$

<b>P0610</b>	<b>Motor I2t reaction</b>	<b>Datatype:</b> U16	<b>Unit:</b> -	<b>Min:</b> 0 <b>Def:</b> 2 <b>Max:</b> 2	Level <b>3</b>
	<b>CStat:</b> CT	<b>Active:</b> first confirm	<b>QuickComm.:</b> No		
	<b>P-Group:</b> MOTOR				

Defines reaction when motor I2t reaches warning threshold.

**Possible Settings:**

- 0 Warning, no reaction, no trip
- 1 Warning, I<sub>max</sub> reduction, trip F0011
- 2 Warning, no reaction, trip F0011

**Dependency:**

See parameter P0611, P0614.

**Note:**

P0610 = 1:  
If the max. permissible current I<sub>max</sub> is reduced, this results in a lower output frequency.

The motor I<sup>2</sup>t monitoring function is used to protect the motor against overheating. The motor temperature will be dependent on many factors, including the size of the motor, the ambient temperature, the previous history of the motors loading, and of course, the load current. (The square of the current actually determines the heating of the motor and the temperature rises with time - hence I<sup>2</sup>t).

Because most motors are cooled by fans integrated in the motor and running at the motor speed, the speed of the motor is also important. Clearly a motor running with a high current (maybe due to boost) and a low speed, will overheat more quickly than one running at 50 or 60 Hz, full load. The MM4 take account of these factors.

<b>P0611</b>	<b>Motor I2t time constant</b>				<b>Min:</b> 0	<b>Level</b> <b>2</b>
	<b>CStat:</b> CT	<b>Datatype:</b> U16	<b>Unit:</b> s	<b>Def:</b> 100		
	<b>P-Group:</b> MOTOR	<b>Active:</b> Immediately	<b>QuickComm.:</b> No	<b>Max:</b> 16000		

Thermal Time constant for the motor.

The time until the thermal limit of a motor is reached, is calculated via the thermal time constant. A higher value increases the time at which the motor thermal limit is reached.

The value of P0611 is estimated according to the motor data during quick commissioning or is calculated using P0340 (Calculating of the motor parameters). When the calculation of motor parameters during quick commission is complete the stored value can be replaced by the value given by the motor manufacturer.

**Example:**

For a 2 pole 1LA7063 motor the value is 8 min (see table). The value for P0611 is calculated as follows:

$$P0611 = 8 \text{ min} \cdot 60 \frac{\text{s}}{\text{min}} = 480 \text{ s}$$

For Siemens standard motors 1LA7 the thermal time constant values are given in minutes (see following table):

Type	2 pole	4 pole	6 pole	8 pole
1LA7050	13	13	-	-
1LA7053	13	13	-	-
1LA7060	8	11	-	-
1LA7063	8	13	12	-
1LA7070	8	10	12	12
1LA7073	8	10	12	12
1LA7080	8	10	12	12
1LA7083	10	10	12	12
1LA7090	5	9	12	12
1LA7096	6	11	12	14
1LA7106	8	12	12	16
1LA7107	-	12	-	16
1LA7113	14	11	13	12
1LA7130	11	10	13	10
1LA7131	11	-	-	-
1LA7133	-	10	14	10
1LA7134	-	-	16	-
1LA7163	15	19	20	12
1LA7164	15	-	-	14
1LA7166	15	19	20	14

**Dependency:**

P0611 < 99 s (I2t-calculation inactive):  
To activate I2t calculation set P0611 to a value > 99 s.

**Note:**

Mode of operation of I<sup>2</sup>t:

The square of the normalized motor current (measured motor current r0027 divided by the rated motor current P0305) weighted with the thermal motor time constant results in the I<sup>2</sup>t value of the motor. In addition, the output frequency (motor speed) is incorporated in the calculation to take into consideration the cooling effect of the motor fan. If parameter P0335 is changed to a force-ventilated motor, then the calculation is appropriately modified. The I<sup>2</sup>t value represents a dimension for the temperature rise / temperature of the motor.

If users do not enter parameters such as P0344 (motor weight), then a value, based on a Siemens motor is used. When required, the motor time constant can be changed using P0611, which is the same as overwriting the calculated value.

The I<sup>2</sup>t value that is obtained is displayed in r0034. If this value reaches the value defined in P0614 (default: 100%), an alarm message A0511 is output and, depending on P0610 a response is initiated or, when a shutdown threshold is reached, a fault is output.

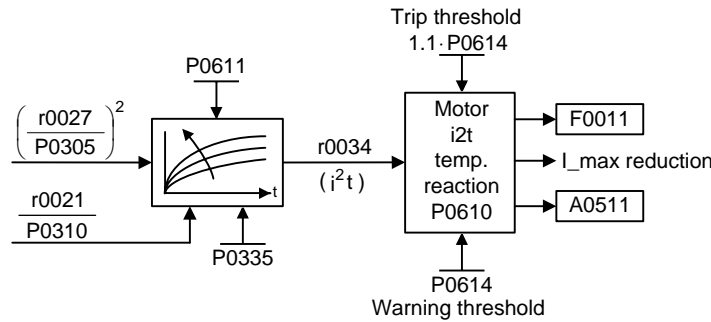

<b>P0614</b>	<b>Motor I2t warning level</b>	<b>Datatype:</b> Float	<b>Unit:</b> %	<b>Min:</b> 0.0	<b>Level</b> <b>2</b>
	<b>CStat:</b> CUT	<b>Active:</b> first confirm	<b>QuickComm.:</b> No	<b>Def:</b> 100.0	
	<b>P-Group:</b> MOTOR			<b>Max:</b> 400.0	

Defines the [%] value at which alarm A0511 (motor overtemperature) is generated.

The motor temperature will be dependent on many factors, including the size of the motor, the ambient temperature, the previous history of the loading of the motor, and of course, the load current. (The square of the current actually determines the heating of the motor and the temperature rises with time - hence I<sup>2</sup>t). A motor-I<sup>2</sup>t-value of P0614 means that the motor has reached its maximum permissible operating temperature. The actual I<sup>2</sup>t-value is displayed in parameter r0034.

**Dependency:**

A motor over-temperature trip (F0011) is produced at 110 % of this level.

$$i^2_{trip} [\%] = i^2_{warn} [\%] \cdot 1.1 = P0614 \cdot 1.1$$

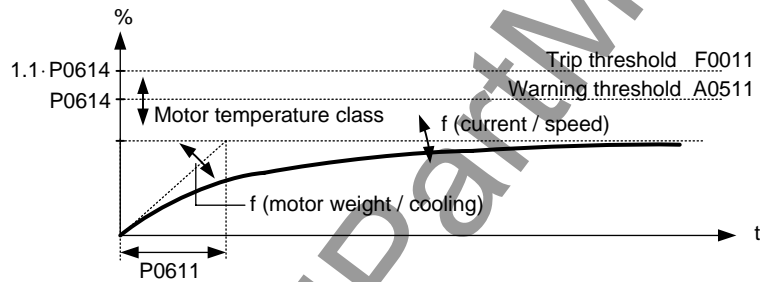

<b>P0640</b>	<b>Motor overload factor [%]</b>	<b>Datatype:</b> Float	<b>Unit:</b> %	<b>Min:</b> 10.0	<b>Level</b> <b>2</b>
	<b>CStat:</b> CUT	<b>Active:</b> Immediately	<b>QuickComm.:</b> Yes	<b>Def:</b> 150.0	
	<b>P-Group:</b> MOTOR			<b>Max:</b> 400.0	

Defines motor overload current limit in [%] relative to P0305 (rated motor current).

**Dependency:**

Limited to maximum inverter current or to 400 % of rated motor current (P0305), whichever is the lower.

$$P0640_{max} = \frac{\min(r0209, 4 \cdot P0305)}{P0305} \cdot 100$$

**Details:**

See function diagram for current limitation.

### 3.5 Command source

<b>P0700</b>	<b>Selection of command source</b>	<b>Min:</b> 0	<b>Level:</b>
	<b>CStat:</b> CT	<b>Datatype:</b> U16	<b>Def:</b> 2
	<b>P-Group:</b> COMMANDS	<b>Active:</b> first confirm	<b>QuickComm.:</b> Yes

Selects digital command source.

**Possible Settings:**

- 0 Factory default setting
- 1 BOP (keypad)
- 2 Terminal
- 4 USS on BOP link
- 5 USS on COM link
- 6 CB on COM link

**Example:**

Changing from P0700 = 1 to P0700 = 2 sets all digital inputs to default settings.

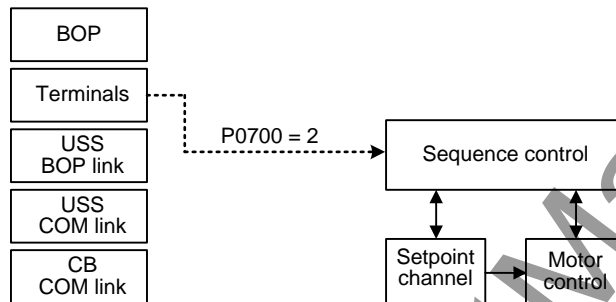

**Notice:**

Setting 4 (USS on BOP link) is also used for STARTER via PC connection kit or AOP control.  
Setting 5 (USS on COM link) is used for remote AOP communications via RS485.



**Caution:**

Be aware, by changing of parameter P0700 all BI parameters are reset to the default value or modified as listed in the table below.

If the Inverter is being controlled via the AOP, select USS (with the corresponding interface) for the Command Source. If the AOP is connected to the BOP-Link Interface, then set Parameter P0700 to the value 4 (P0700 = 4).

**Note:**

Changing this parameter sets (to default) all settings on item selected (see table).

	P0700 = 0	P0700 = 1	P0700 = 2	P0700 = 4	P0700 = 5	P0700 = 6
P0701	1	0	1	0	0	0
P0702	12	0	12	0	0	0
P0703	9	9	9	9	9	9
P0704	0	0	0	0	0	0
P0705	15	15	15	15	15	15
P0731	52.3	52.3	52.3	52.3	52.3	52.3
P0800	0.0	0.0	0.0	0.0	0.0	0.0
P0801	0.0	0.0	0.0	0.0	0.0	0.0
P0840	722.0	19.0	722.0	2032.0	2036.0	2090.0
P0842	0.0	0.0	0.0	0.0	0.0	0.0
P0844	1.0	19.1	1.0	2032.1	2036.1	2090.1
P0845	19.1	19.1	19.1	19.1	19.1	19.1
P0848	1.0	1.0	1.0	2032.2	2036.2	2090.2
P0849	1.0	1.0	1.0	1.0	1.0	1.0
P0852	1.0	1.0	1.0	2032.3	2036.3	2090.3

	P0700 = 0	P0700 = 1	P0700 = 2	P0700 = 4	P0700 = 5	P0700 = 6
P1020	0.0	0.0	0.0	0.0	0.0	0.0
P1021	0.0	0.0	0.0	0.0	0.0	0.0
P1022	0.0	0.0	0.0	0.0	0.0	0.0
P1035	19.13	19.13	19.13	2032.13	2036.13	2090.13
P1036	19.14	19.14	19.14	2032.14	2036.14	2090.14
P1055	0.0	19.8	0.0	2032.8	2036.8	2090.8
P1056	0.0	0.0	0.0	2032.9	2036.9	2090.9
P1074	0.0	0.0	0.0	0.0	0.0	0.0
P1110	0.0	0.0	0.0	0.0	0.0	0.0
P1113	722.1	19.11	722.1	2032.11	2036.11	2090.11
P1124	0.0	0.0	0.0	0.0	0.0	0.0
P1140	1.0	1.0	1.0	2032.4	2036.4	2090.4
P1141	1.0	1.0	1.0	2032.5	2036.5	2090.5
P1142	1.0	1.0	1.0	2032.6	2036.6	2090.6
P1230	0.0	0.0	0.0	0.0	0.0	0.0
P2103	722.2	722.2	722.2	722.2	722.2	722.2
P2104	0.0	0.0	0.0	2032.7	2036.7	2090.7
P2106	1.0	1.0	1.0	1.0	1.0	1.0
P2200	0.0	0.0	0.0	0.0	0.0	0.0
P2220	0.0	0.0	0.0	0.0	0.0	0.0
P2221	0.0	0.0	0.0	0.0	0.0	0.0
P2222	0.0	0.0	0.0	0.0	0.0	0.0
P2235	19.13	19.13	19.13	2032.13	2036.13	2090.13
P2236	19.14	19.14	19.14	2032.14	2036.14	2090.14

The following parameters are not overwritten when changing P0700:

P0810

## 3.6 Digital inputs

<b>P0701</b>	<b>Function of digital input 1</b>				<b>Min:</b> 0	<b>Level</b> <b>2</b>
	<b>CStat:</b> CT	<b>Datatype:</b> U16	<b>Unit:</b> -	<b>Def:</b> 1		
	<b>P-Group:</b> COMMANDS	<b>Active:</b> first confirm	<b>QuickComm.:</b> No	<b>Max:</b> 99		

Selects function of digital input 1.

**DIN channel (e.g. DIN1 - PNP (P0725 = 1))**

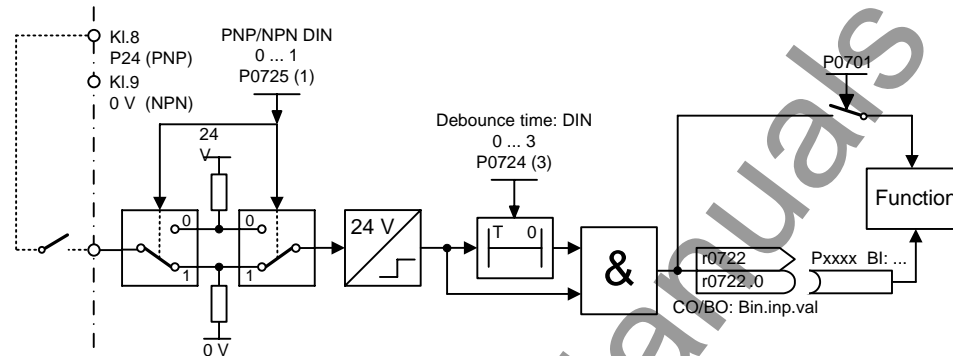

**Possible Settings:**

- 0 Digital input disabled
- 1 ON/OFF1
- 2 ON reverse /OFF1
- 3 OFF2 - coast to standstill
- 4 OFF3 - quick ramp-down
- 9 Fault acknowledge
- 10 JOG right
- 11 JOG left
- 12 Reverse
- 13 MOP up (increase frequency)
- 14 MOP down (decrease frequency)
- 15 Fixed setpoint (Direct selection)
- 16 Fixed setpoint (Direct selection + ON)
- 17 Fixed setpoint (Binary coded selection + ON)
- 21 Local/remote
- 25 DC brake enable
- 29 External trip
- 33 Disable additional freq setpoint
- 99 Enable BICO parameterization

**Dependency:**

- Setting 99 (enable BICO parameterization) requires
  - P0700 command source or
  - P0010 = 1, P3900 = 1, 2 or 3 quick commissioning or
  - P0010 = 30, P0970 = 1 factory reset in order to reset.

**Notice:**

- Setting 99 (BICO) for expert use only.
- To change back the setting 99 in any of the DIN function parameters it is necessary to alter P0700.
- For reversing the drive 2 DINs are necessary : one for ON command and another for Reverse.
- Settings 3 (OFF2) and 4 (OFF3) are low active.

<b>P0702</b>	<b>Function of digital input 2</b>				<b>Min:</b> 0	<b>Level</b> <b>2</b>
	<b>CStat:</b> CT	<b>Datatype:</b> U16	<b>Unit:</b> -	<b>Def:</b> 12		
	<b>P-Group:</b> COMMANDS	<b>Active:</b> first confirm	<b>QuickComm.:</b> No	<b>Max:</b> 99		

Selects function of digital input 2.

**Possible Settings:**

- 0 Digital input disabled
- 1 ON/OFF1
- 2 ON reverse /OFF1
- 3 OFF2 - coast to standstill
- 4 OFF3 - quick ramp-down
- 9 Fault acknowledge
- 10 JOG right
- 11 JOG left
- 12 Reverse
- 13 MOP up (increase frequency)
- 14 MOP down (decrease frequency)
- 15 Fixed setpoint (Direct selection)
- 16 Fixed setpoint (Direct selection + ON)
- 17 Fixed setpoint (Binary coded selection + ON)
- 21 Local/remote
- 25 DC brake enable
- 29 External trip
- 33 Disable additional freq setpoint
- 99 Enable BICO parameterization

**Details:**

See P0701 (function of digital input1).

<b>P0703</b>	<b>Function of digital input 3</b>				<b>Min:</b> 0	<b>Level</b> <b>2</b>
	<b>CStat:</b> CT	<b>Datatype:</b> U16	<b>Unit:</b> -	<b>Def:</b> 9		
	<b>P-Group:</b> COMMANDS	<b>Active:</b> first confirm	<b>QuickComm.:</b> No	<b>Max:</b> 99		

Selects function of digital input 3.

**Possible Settings:**

- 0 Digital input disabled
- 1 ON/OFF1
- 2 ON reverse /OFF1
- 3 OFF2 - coast to standstill
- 4 OFF3 - quick ramp-down
- 9 Fault acknowledge
- 10 JOG right
- 11 JOG left
- 12 Reverse
- 13 MOP up (increase frequency)
- 14 MOP down (decrease frequency)
- 15 Fixed setpoint (Direct selection)
- 16 Fixed setpoint (Direct selection + ON)
- 17 Fixed setpoint (Binary coded selection + ON)
- 21 Local/remote
- 25 DC brake enable
- 29 External trip
- 33 Disable additional freq setpoint
- 99 Enable BICO parameterization

**Details:**

See P0701 (function of digital input 1).

<b>P0704</b>	<b>Function of digital input 4</b>				<b>Min:</b> 0	<b>Level</b> <b>2</b>
	<b>CStat:</b> CT	<b>Datatype:</b> U16	<b>Unit:</b> -	<b>Def:</b> 0		
	<b>P-Group:</b> COMMANDS	<b>Active:</b> first confirm	<b>QuickComm.:</b> No	<b>Max:</b> 99		

Selects function of digital input 4 (via analog input).

**Possible Settings:**

- 0 Digital input disabled
- 1 ON/OFF1
- 2 ON reverse /OFF1
- 3 OFF2 - coast to standstill
- 4 OFF3 - quick ramp-down
- 9 Fault acknowledge
- 10 JOG right
- 11 JOG left
- 12 Reverse
- 13 MOP up (increase frequency)
- 14 MOP down (decrease frequency)
- 21 Local/remote
- 25 DC brake enable
- 29 External trip
- 33 Disable additional freq setpoint
- 99 Enable BICO parameterization

**Details:**

See P0701 (function of digital input 1).

<b>P0719[2]</b>	<b>Selection of cmd. &amp; freq. setp.</b>			<b>Min:</b> 0	<b>Level</b> <b>3</b>
	<b>CStat:</b> CT	<b>Datatype:</b> U16	<b>Unit:</b> -	<b>Def:</b> 0	
	<b>P-Group:</b> COMMANDS	<b>Active:</b> first confirm	<b>QuickComm.:</b> No	<b>Max:</b> 67	

Central switch to select control command source for inverter.

Switches command and setpoint source between freely programmable BICO parameters and fixed command/setpoint profiles. Command and setpoint sources can be changed independently.

The tens digit chooses the command source and the units digit chooses the setpoint source.

The two indices of this parameter are used for local/remote switching. The local/remote signal switches between these settings.

The default setting is 0 for the first index (i.e. normal parameterization is active).

The second index is for control via BOP (i.e. activating the local/remote signal will then switch to BOP).

**Possible Settings:**

0	Cmd = BICO parameter	Setpoint = BICO parameter
1	Cmd = BICO parameter	Setpoint = MOP setpoint
2	Cmd = BICO parameter	Setpoint = Analog setpoint
3	Cmd = BICO parameter	Setpoint = Fixed frequency
4	Cmd = BICO parameter	Setpoint = USS on BOP link
5	Cmd = BICO parameter	Setpoint = USS on COM link
6	Cmd = BICO parameter	Setpoint = CB on COM link
7	Cmd = BICO parameter	Setpoint = Analog 2 setp
10	Cmd = BOP	Setpoint = BICO parameter
11	Cmd = BOP	Setpoint = MOP setpoint
12	Cmd = BOP	Setpoint = Analog setpoint
13	Cmd = BOP	Setpoint = Fixed frequency
15	Cmd = BOP	Setpoint = USS on COM link
16	Cmd = BOP	Setpoint = CB on COM link
17	Cmd = BOP	Setpoint = Analog 2 setp
40	Cmd = USS on BOP link	Setpoint = BICO parameter
41	Cmd = USS on BOP link	Setpoint = MOP setpoint
42	Cmd = USS on BOP link	Setpoint = Analog setpoint
43	Cmd = USS on BOP link	Setpoint = Fixed frequency
44	Cmd = USS on BOP link	Setpoint = USS on BOP link
45	Cmd = USS on BOP link	Setpoint = USS on COM link
46	Cmd = USS on BOP link	Setpoint = CB on COM link
47	Cmd = USS on BOP link	Setpoint = Analog 2 setp
50	Cmd = USS on COM link	Setpoint = BICO parameter
51	Cmd = USS on COM link	Setpoint = MOP setpoint
52	Cmd = USS on COM link	Setpoint = Analog setpoint
53	Cmd = USS on COM link	Setpoint = Fixed frequency
54	Cmd = USS on COM link	Setpoint = USS on BOP link
55	Cmd = USS on COM link	Setpoint = USS on COM link
57	Cmd = USS on COM link	Setpoint = Analog 2 setp
60	Cmd = CB on COM link	Setpoint = BICO parameter
61	Cmd = CB on COM link	Setpoint = MOP setpoint
62	Cmd = CB on COM link	Setpoint = Analog setpoint
63	Cmd = CB on COM link	Setpoint = Fixed frequency
64	Cmd = CB on COM link	Setpoint = USS on BOP link
66	Cmd = CB on COM link	Setpoint = CB on COM link
67	Cmd = CB on COM link	Setpoint = Analog 2 setp

**Index:**

P0719[0] : 1st Control source (Remote)  
P0719[1] : 2nd Control source (Local)

**Note:**

Using parameter P0719, it is possible to select the command or setpoint sources without changing the BICO connections (this is contrary to P0700 / P1000). However, it is not possible to change the complete connection table (refer to P0700 and P1000). Using P0719, depending on the value, only the BICO parameters listed in the following table are internally overwritten - this means that these BICO parameters are inactive.

**Command source:**

	P0719 =				
	0 ... 9	10 ... 19	40 ... 49	50 ... 59	60 ... 69
P0840	X	–	–	–	–
P0844	X	–	–	–	–
P0848	X	X	–	–	–
P0852	X	X	–	–	–
P1035	X	–	–	–	–
P1036	X	X	–	–	–
P1055	X	–	–	–	–
P1056	X	X	–	–	–
P1113	X	–	–	–	–
P1140	X	X	–	–	–
P1141	X	X	–	–	–
P1142	X	X	–	–	–
P1143	X	X	–	–	–

**Setpoint source:**

	P0719 =	
	0, 10, 20, 40, 50, 60	all other values
P1070	X	–

X = BICO parameter active  
 – = BICO parameter inactive

BICO connections made previously remain unchanged.

<b>r0720</b>	<b>Number of digital inputs</b>	<b>Min:</b> -	<b>Level</b> <b>3</b>
	<b>Datatype:</b> U16	<b>Unit:</b> -	
	<b>P-Group:</b> COMMANDS	<b>Def:</b> - <b>Max:</b> -	

Displays number of digital inputs.

<b>r0722</b>	<b>CO/BO: Binary input values</b>	<b>Min:</b> -	<b>Level</b> <b>2</b>
	<b>Datatype:</b> U16	<b>Unit:</b> -	
	<b>P-Group:</b> COMMANDS	<b>Def:</b> - <b>Max:</b> -	

Displays status of digital inputs.

**Bitfields:**

Bit00	Digital input 1	0	OFF	1	ON
Bit01	Digital input 2	0	OFF	1	ON
Bit02	Digital input 3	0	OFF	1	ON
Bit03	Digital input 4 (via ADC)	0	OFF	1	ON

**Note:**

Segment is lit when signal is active.

<b>P0724</b>	<b>Debounce time for digital inputs</b>	<b>Min:</b> 0	<b>Level</b> <b>3</b>	
	<b>CStat:</b> CT	<b>Datatype:</b> U16		<b>Def:</b> 3
	<b>P-Group:</b> COMMANDS	<b>Active:</b> Immediately		<b>QuickComm.:</b> No <b>Max:</b> 3

Defines debounce time (filtering time) used for digital inputs.

**Possible Settings:**

- 0 No debounce time
- 1 2.5 ms debounce time
- 2 8.2 ms debounce time
- 3 12.3 ms debounce time

<b>P0725</b>	<b>PNP / NPN digital inputs</b>				<b>Min:</b> 0	<b>Level</b> <b>3</b>
	<b>CStat:</b> CT	<b>Datatype:</b> U16	<b>Unit:</b> -	<b>Def:</b> 1		
	<b>P-Group:</b> COMMANDS	<b>Active:</b> Immediately	<b>QuickComm.:</b> No	<b>Max:</b> 1		

Switches between active high (PNP) and active low (NPN). This is valid for all digital inputs simultaneously.

The following is valid by using the internal supply:

**Possible Settings:**

- 0 NPN mode ==> low active
- 1 PNP mode ==> high active

**Value:**

NPN: Terminals 5/6/7 must be connected via terminal 9 (0 V).  
 PNP: Terminals 5/6/7 must be connected via terminal 8 (24 V).

### 3.7 Digital outputs

<b>r0730</b>	<b>Number of digital outputs</b>				<b>Min:</b> -	<b>Level</b> <b>3</b>
					<b>Def:</b> -	
	<b>P-Group:</b> COMMANDS	<b>Datatype:</b> U16	<b>Unit:</b> -	<b>Max:</b> -		

Displays number of digital outputs (relays).

<b>P0731</b>	<b>BI: Function of digital output 1</b>	<b>Min:</b> 0:0	<b>Level</b> <b>2</b>	
	<b>CStat:</b> CUT	<b>Datatype:</b> U32		<b>Def:</b> 52:3
	<b>P-Group:</b> COMMANDS	<b>Active:</b> first confirm		<b>QuickComm.:</b> No

Defines source of digital output 1.

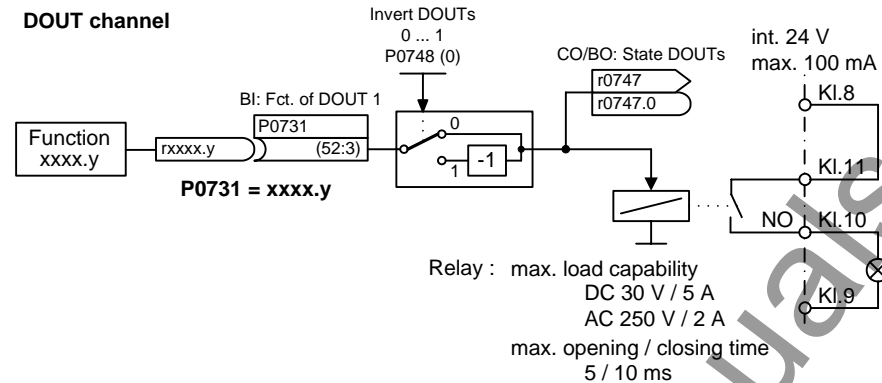

**Common Settings:**

52.0	Drive ready	0	Closed
52.1	Drive ready to run	0	Closed
52.2	Drive running	0	Closed
52.3	Drive fault active	0	Closed
52.4	OFF2 active	1	Closed
52.5	OFF3 active	1	Closed
52.6	Switch on inhibit active	0	Closed
52.7	Drive warning active	0	Closed
52.8	Deviation setpoint/actual value	1	Closed
52.9	PZD control (Process Data Control)	0	Closed
52.A	Maximum frequency reached	0	Closed
52.B	Warning: Motor current limit	1	Closed
52.C	Motor holding brake (MHB) active	0	Closed
52.D	Motor overload	1	Closed
52.E	Motor running direction right	0	Closed
52.F	Inverter overload	1	Closed
53.0	DC brake active	0	Closed
53.1	Act. freq. f_act > P2167 (f_off)	0	Closed
53.2	Act. freq. f_act <= P1080 (f_min)	0	Closed
53.3	Act. current r0027 > P2170	0	Closed
53.4	Act. freq. f_act > P2155 (f_1)	0	Closed
53.5	Act. freq. f_act <= P2155 (f_1)	0	Closed
53.6	Act. freq. f_act >= setpoint	0	Closed
53.7	Act. Vdc r0026 < P2172	0	Closed
53.8	Act. Vdc r0026 > P2172	0	Closed
53.A	PID output r2294 == P2292 (PID_min)	0	Closed
53.B	PID output r2294 == P2291 (PID_max)	0	Closed

**Details:**

Display functions ==> see parameter r0052, r0053  
 Motor holding brake ==> see parameter P1215  
 DC brake ==> see parameter P1232, P1233

<b>r0747</b>	<b>CO/BO: State of digital outputs</b>	<b>Min:</b> -	<b>Level</b> <b>3</b>	
	<b>CStat:</b> CUT	<b>Datatype:</b> U16		<b>Def:</b> -
	<b>P-Group:</b> COMMANDS	<b>Active:</b> first confirm		<b>QuickComm.:</b> No

Displays status of digital outputs (also includes inversion of digital outputs via P0748).

**Bitfields:**

Bit00	Digital output 1 energized	0	NO	1	YES
-------	----------------------------	---	----	---	-----

**Dependency:**

Bit 0 = 0 :  
Relay de-energized / contacts open

Bit 0 = 1 :  
Relay energized / contacts closed

<b>P0748</b>	<b>Invert digital outputs</b>	<b>Min:</b> 0	<b>Level</b> <b>3</b>	
	<b>CStat:</b> CUT	<b>Datatype:</b> U16		<b>Def:</b> 0
	<b>P-Group:</b> COMMANDS	<b>Active:</b> first confirm		<b>QuickComm.:</b> No

Defines high and low states of relay for a given function.

**Bitfields:**

Bit00	Invert digital output 1	0	NO	1	YES
-------	-------------------------	---	----	---	-----

### 3.8 Analog inputs

<b>r0750</b>	<b>Number of ADCs</b>	Datatype: U16	Unit: -	Min: - Def: - Max: -	Level <b>3</b>
	P-Group: TERMINAL				
Displays number of analog inputs available.					
<b>r0751</b>	<b>CO/BO: Status word of ADC</b>	Datatype: U16	Unit: -	Min: - Def: - Max: -	Level <b>3</b>
	P-Group: TERMINAL				

Displays status of analog input.

**Bitfields:**

Bit00 Signal lost on ADC 1 0 NO 1 YES

**Dependency:**

The following limitations/secondary conditions apply for the wire breakage monitoring:

- For P0756, the monitoring must be activated
- Width of the ADC deadzone P0761 > 0
- Wire breakage / signal loss F0080 is detected if the ADC input quantity is less than 0.5 \* P0761.

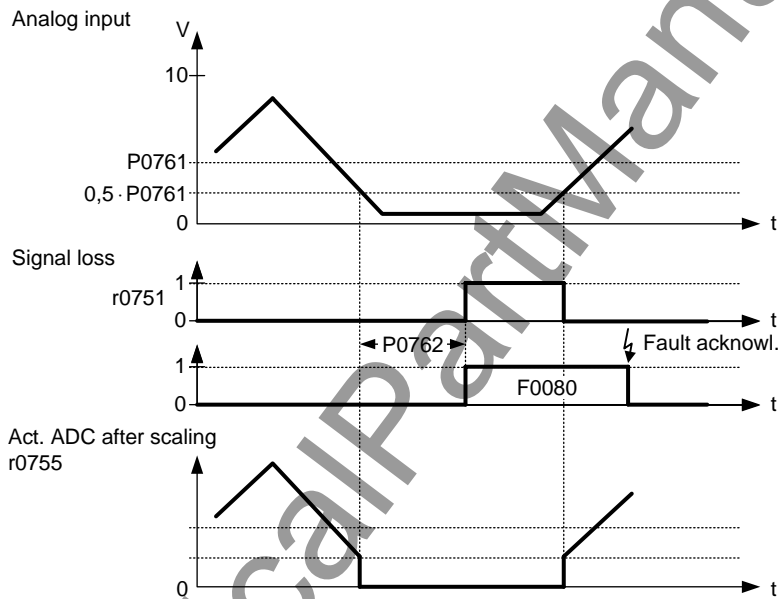

<b>r0752</b>	<b>Act. input of ADC [V]</b>	Datatype: Float	Unit: -	Min: - Def: - Max: -	Level <b>2</b>
	P-Group: TERMINAL				

Displays smoothed analog input value in volts before the characteristic block.

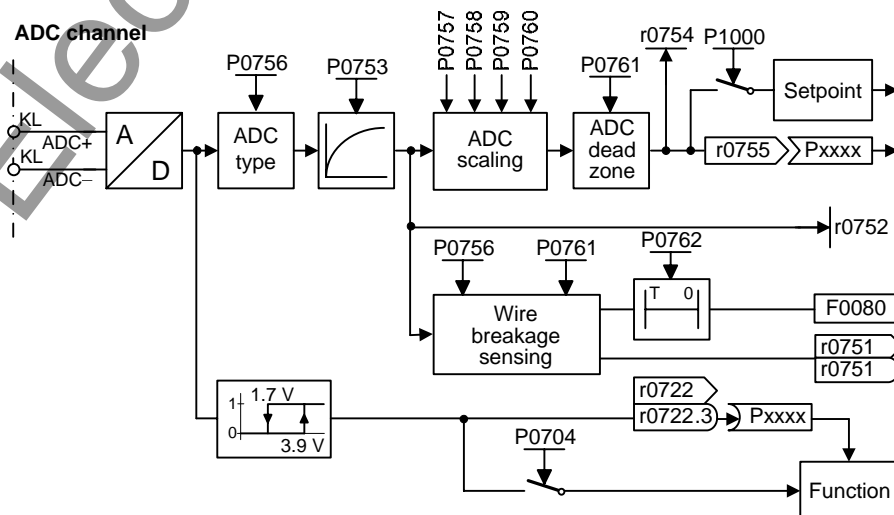

<b>P0753</b>	<b>Smooth time ADC</b>	<b>Datatype:</b> U16	<b>Unit:</b> ms	<b>Min:</b> 0	<b>Level</b> <b>3</b>
	<b>CStat:</b> CUT	<b>Active:</b> first confirm	<b>QuickComm.:</b> No	<b>Def:</b> 3	
	<b>P-Group:</b> TERMINAL			<b>Max:</b> 10000	

Defines filter time (PT1 filter) in [ms] for analog input.

**Note:**

Increasing this time (smooth) reduces jitter but slows down response to the analog input.

P0753 = 0 : No filtering

<b>r0754</b>	<b>Act. ADC value after scaling [%]</b>	<b>Datatype:</b> Float	<b>Unit:</b> %	<b>Min:</b> -	<b>Level</b> <b>2</b>
	<b>P-Group:</b> TERMINAL			<b>Def:</b> -	
				<b>Max:</b> -	

Shows smoothed value of analog input in [%] after scaling block.

**Dependency:**

P0757 to P0760 define range (ADC scaling).

<b>r0755</b>	<b>CO: Act. ADC after scal. [4000h]</b>	<b>Datatype:</b> I16	<b>Unit:</b> -	<b>Min:</b> -	<b>Level</b> <b>2</b>
	<b>P-Group:</b> TERMINAL			<b>Def:</b> -	
				<b>Max:</b> -	

Displays analog input, scaled using ASPmin and ASPmax.

Analog setpoint (ASP) from the analog scaling block can vary from min. analog setpoint (ASPmin) to a max. analog setpoint (ASPmax) as shown in P0757 (ADC scaling).

The largest magnitude (value without sign) of ASPmin and ASPmax defines the scaling of 16384.

By associating parameter r0755 with an internal value (e.g. frequency setpoint), a scaled value is calculated internally by the MM4. The frequency value is calculated using the following equation:

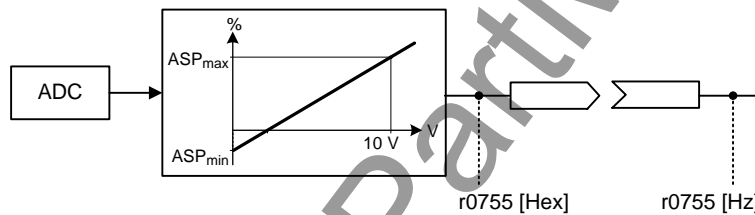

$$r0755 \text{ [Hz]} = \frac{r0755 \text{ [Hex]}}{4000 \text{ [Hex]}} \cdot P2000 \cdot \frac{\max(|ASP_{max}|, |ASP_{min}|)}{100\%}$$

**Example:**

Case a:

- ASPmin = 300 %, ASPmax = 100 % then 16384 represents 300 %.
- This parameter will vary from 5461 to 16384.

Case b:

- ASPmin = -200 %, ASPmax = 100 % then 16384 represents 200 %.
- This parameter will vary from -16384 to +8192.

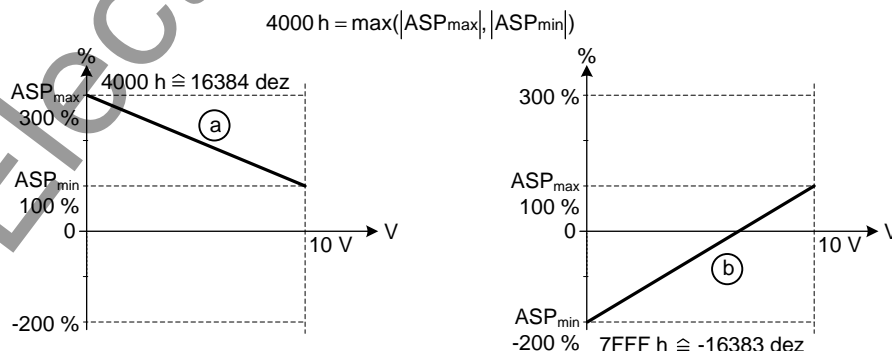

**Note:**

- This value is used as an input to analog BICO connectors.
- ASPmax represents the highest analog setpoint (this may be at 10 V).
- ASPmin represents the lowest analog setpoint (this may be at 0 V).

**Details:**

See parameters P0757 to P0760 (ADC scaling)

<b>P0756</b>	<b>Type of ADC</b>			<b>Min:</b> 0	Level <b>2</b>
	<b>CStat:</b> CT	<b>Datatype:</b> U16	<b>Unit:</b> -	<b>Def:</b> 0	
	<b>P-Group:</b> TERMINAL	<b>Active:</b> first confirm	<b>QuickComm.:</b> No	<b>Max:</b> 1	

Defines type of analog input and also enables analog input monitoring.

**Possible Settings:**

- 0 Unipolar voltage input (0 to +10 V)
- 1 Unipolar voltage input with monitoring (0 to 10 V)

**Notice:**

When monitoring is enabled and a deadband defined (P0761), a fault condition will be generated (F0080) if the analog input voltage falls below 50 % of the deadband voltage.

**Details:**

See P0757 to P0760 (ADC scaling).

<b>P0757</b>	<b>Value x1 of ADC scaling [V]</b>			<b>Min:</b> 0	Level <b>2</b>
	<b>CStat:</b> CUT	<b>Datatype:</b> Float	<b>Unit:</b> V	<b>Def:</b> 0	
	<b>P-Group:</b> TERMINAL	<b>Active:</b> first confirm	<b>QuickComm.:</b> No	<b>Max:</b> 10	

Parameters P0757 - P0760 configure the input scaling as shown in the diagram:

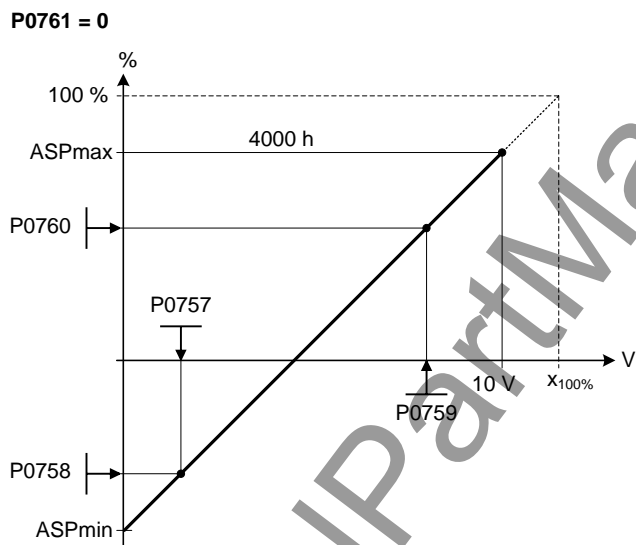

Where:

- Analog setpoints represent a [%] of the normalized frequency in P2000.
- Analog setpoints may be larger than 100 %.
- ASPmax represents highest analog setpoint (this may be at 10 V).
- ASPmin represents lowest analog setpoint (this may be at 0 V).
- Default values provide a scaling of 0 V = 0 %, and 10 V = 100 %.

**Note:**

The ADC-linear characteristic is described by 4 coordinates, based on a two-point equation:

$$\frac{y - P0758}{x - P0757} = \frac{P0760 - P0758}{P0759 - P0757}$$

For calculations the point-gradient form (offset and gradient) is more advantageous:

$$y = m \cdot x + y_0$$

The transformation between these two forms is given by:

$$m = \frac{P0760 - P0758}{P0759 - P0757} \quad y_0 = \frac{P0758 \cdot P0759 - P0757 \cdot P0760}{P0759 - P0757}$$

For scaling of the input the value of y\_max and x\_min has to be determined. This is done by the following equations:

$$x_{min} = \frac{P0760 \cdot P0757 - P0758 \cdot P0759}{P0760 - P0758}$$

$$y_{max} = (x_{max} - x_{min}) \cdot \frac{P0760 - P0758}{P0759 - P0757}$$

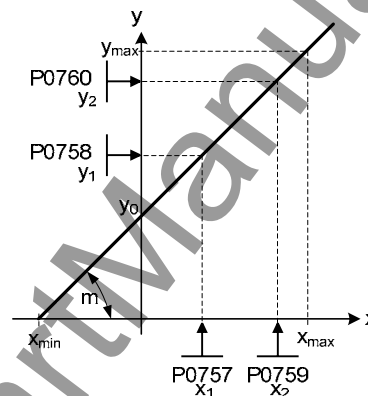

**Notice:**

The value x2 of ADC scaling P0759 must be greater than the value x1 of ADC scaling P0757.

<b>P0758</b>	<b>Value y1 of ADC scaling</b>	<b>Min:</b> -99999.9	<b>Level</b>
	<b>CStat:</b> CUT	<b>Datatype:</b> Float	<b>Def:</b> 0.0
	<b>P-Group:</b> TERMINAL	<b>Active:</b> first confirm	<b>QuickComm.:</b> No
		<b>Max:</b> 99999.9	<b>2</b>

Sets value of Y1 in [%] as described in P0757 (ADC scaling)

**Dependency:**

Affects P2000 to 2002 (reference frequency, voltage, current) depending on which setpoint is to be generated.

<b>P0759</b>	<b>Value x2 of ADC scaling [V]</b>	<b>Min:</b> 0	<b>Level</b>
	<b>CStat:</b> CUT	<b>Datatype:</b> Float	<b>Def:</b> 10
	<b>P-Group:</b> TERMINAL	<b>Active:</b> first confirm	<b>QuickComm.:</b> No
		<b>Max:</b> 10	<b>2</b>

Sets value of X2 as described in P0757 (ADC scaling).

**Notice:**

The value x2 of ADC scaling P0759 must be greater than the value x1 of ADC scaling P0757.

<b>P0760</b>	<b>Value y2 of ADC scaling</b>	<b>Min:</b> -99999.9	<b>Level</b>
	<b>CStat:</b> CUT	<b>Datatype:</b> Float	<b>Def:</b> 100.0
	<b>P-Group:</b> TERMINAL	<b>Active:</b> first confirm	<b>QuickComm.:</b> No
		<b>Max:</b> 99999.9	<b>2</b>

Sets value of Y2 in [%] as described in P0757 (ADC scaling).

**Dependency:**

Affects P2000 to 2002 (reference frequency, voltage, current) depending on which setpoint is to be generated.

<b>P0761</b>	<b>Width of ADC deadband [V]</b>	<b>Min:</b> 0	<b>Level</b>
	<b>CStat:</b> CUT	<b>Datatype:</b> Float	<b>Def:</b> 0
	<b>P-Group:</b> TERMINAL	<b>Active:</b> first confirm	<b>QuickComm.:</b> No
		<b>Max:</b> 10	<b>2</b>

Defines width of deadband on analog input. The diagrams below explain its use.

**Example:**

The below example produces a 2 to 10 V analog input 0 to 50 Hz (ADC value 2 to 10 V, 0 to 50 Hz):

- P2000 = 50 Hz
- P0759 = 8 V    P0760 = 75 %
- P0757 = 2 V    P0758 = 0 %
- P0761 = 2 V
- P0756 = 0 or 1

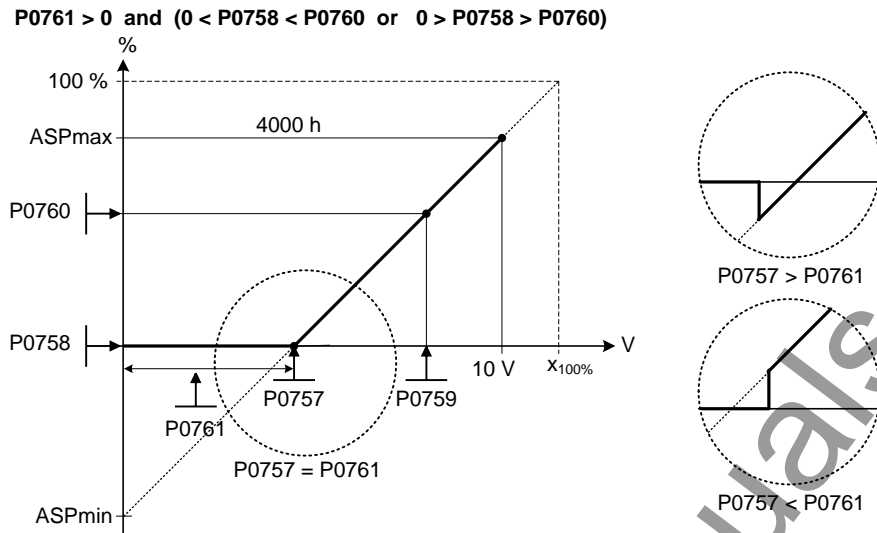

The below example produces a 0 to 10 V analog input (-50 to +50 Hz) with center zero and a "holding point" 0.2 V wide (0.1 V to each side of center, ADC value 0 to 10 V, -50 to +50 Hz):

- P2000 = 50 Hz
- P0759 = 8 V    P0760 = 75 %
- P0757 = 2 V    P0758 = -75 %
- P0761 = 0.1 V
- P0756 = 0 or 1

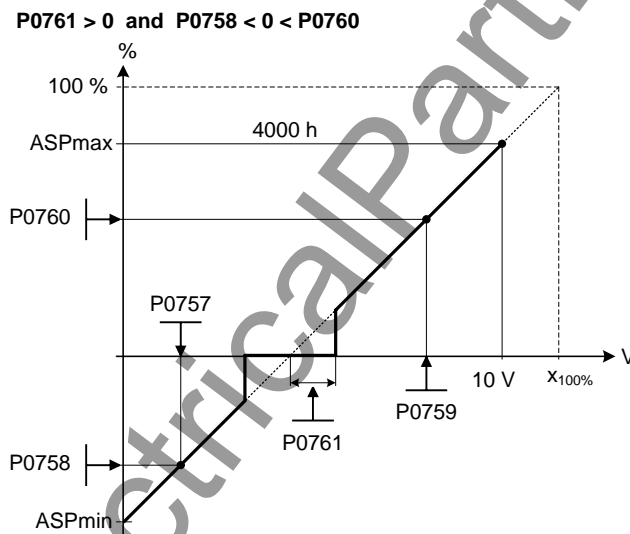

**Note:**

P0761[x] = 0 : No deadband active.

Deadband starts from 0 V to value of P0761, if both values of P0758 and P0760 (y coordinates of ADC scaling) are positive or negative respectively. However, deadband is active in both directions from point of intersection (x axis with ADC scaling curve), if sign of P0758 and P0760 are opposite.

Min. frequency P1080 should be zero when using center zero setup. There is no hysteresis at the end of the deadband.

<b>P0762</b>	<b>Delay for loss of signal action</b>	<b>Min:</b> 0	<b>Level</b>
	<b>CStat:</b> CUT	<b>Datatype:</b> U16	<b>Def:</b> 10
	<b>P-Group:</b> TERMINAL	<b>Active:</b> Immediately	<b>QuickComm.:</b> No
		<b>Max:</b> 10000	<b>3</b>

Defines time delay between loss of analog setpoint and appearance of fault code F0080.

**Note:**

Expert users can choose the desired reaction to F0080 (default is OFF2).

### 3.9 Analog outputs

<b>r0770</b>	<b>Number of DACs</b>	<b>Datatype:</b> U16	<b>Unit:</b> -	<b>Min:</b> - <b>Def:</b> - <b>Max:</b> -	<b>Level</b> <b>3</b>
<b>P-Group:</b> TERMINAL					

Displays number of analog outputs available.

<b>P0771</b>	<b>CI: DAC</b>	<b>Datatype:</b> U32	<b>Unit:</b> -	<b>Min:</b> 0:0 <b>Def:</b> 21:0 <b>Max:</b> 4000:0	<b>Level</b> <b>2</b>
<b>CStat:</b> CUT					
<b>P-Group:</b> TERMINAL					
<b>Active:</b> first confirm					
<b>QuickComm.:</b> No					

Defines function of the 0 - 20 mA analog output.

**Common Settings:**

- 21 CO: Act. frequency (scaled to P2000)
- 24 CO: Act. output frequency (scaled to P2000)
- 25 CO: Act. output voltage (scaled to P2001)
- 26 CO: Act. filtered DC-link volt. (scaled to P2001)
- 27 CO: Act. output current (scaled to P2002)

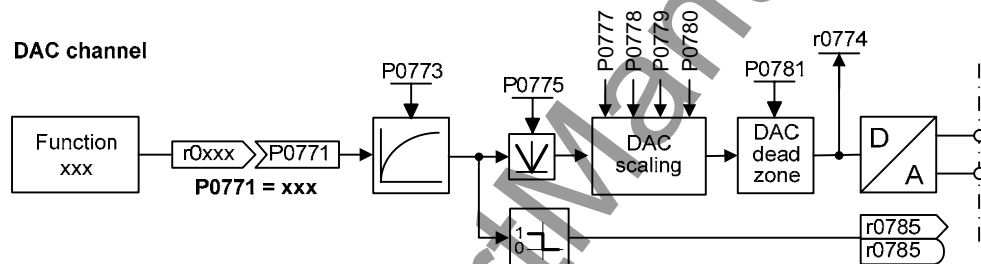

<b>P0773</b>	<b>Smooth time DAC</b>	<b>Datatype:</b> U16	<b>Unit:</b> ms	<b>Min:</b> 0 <b>Def:</b> 2 <b>Max:</b> 1000	<b>Level</b> <b>2</b>
<b>CStat:</b> CUT					
<b>P-Group:</b> TERMINAL					
<b>Active:</b> first confirm					
<b>QuickComm.:</b> No					

Defines smoothing time [ms] for analog output signal. This parameter enables smoothing for DAC using a PT1 filter.

**Dependency:**

P0773 = 0: Deactivates filter.

<b>r0774</b>	<b>Act. DAC value [mA]</b>	<b>Datatype:</b> Float	<b>Unit:</b> -	<b>Min:</b> - <b>Def:</b> - <b>Max:</b> -	<b>Level</b> <b>2</b>
<b>P-Group:</b> TERMINAL					

Shows value of analog output in [mA] after filtering and scaling.

<b>P0775</b>	<b>Permit absolute value</b>	<b>Datatype:</b> U16	<b>Unit:</b> -	<b>Min:</b> 0 <b>Def:</b> 0 <b>Max:</b> 1	<b>Level</b> <b>2</b>
<b>CStat:</b> CT					
<b>P-Group:</b> TERMINAL					
<b>Active:</b> first confirm					
<b>QuickComm.:</b> No					

Decides if the absolute value of the analog output is used. If enabled, this parameter will take the absolute value of the value to be outputted. If the value was originally negative then the corresponding bit in r0785 is set, otherwise it is cleared.

**Possible Settings:**

- 0 OFF
- 1 ON

<b>P0776</b>	<b>Type of DAC</b>	<b>Datatype:</b> U16	<b>Unit:</b> -	<b>Min:</b> 0 <b>Def:</b> 0 <b>Max:</b> 0	<b>Level</b> <b>2</b>
<b>CStat:</b> CT					
<b>P-Group:</b> TERMINAL					
<b>Active:</b> first confirm					
<b>QuickComm.:</b> No					

Defines type of analog output.

**Possible Settings:**

- 0 Current output

**Note:**

The analog output is designed as a current output with a range of 0...20 mA.

For a voltage output with a range of 0...10 V an external resistor of 500 Ohms has to be connected at the terminals (12/13).

<b>P0777</b>	<b>Value x1 of DAC scaling</b>	<b>Datatype:</b> Float	<b>Unit:</b> %	<b>Min:</b> -99999.0	<b>Level</b> <b>2</b>
	<b>CStat:</b> CUT	<b>Active:</b> first confirm	<b>QuickComm.:</b> No	<b>Def:</b> 0.0	
	<b>P-Group:</b> TERMINAL			<b>Max:</b> 99999.0	

Defines x1 output characteristic in [%]. Scaling block is responsible for adjustment of output value defined in P0771 (DAC connector input).

Parameters of DAC scaling block (P0777 ... P0781) work as follows:

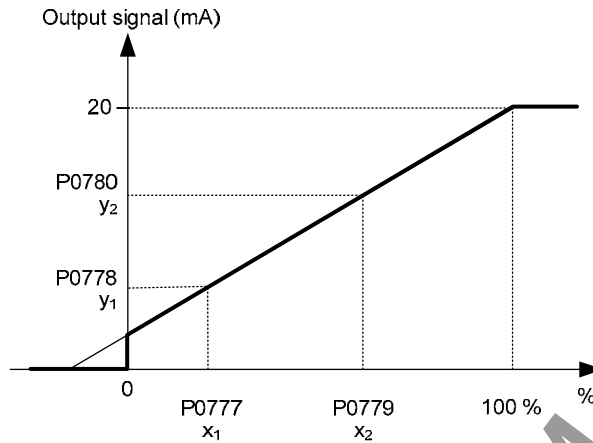

Where:  
Points P1 (x1, y1) and P2 (x2, y2) can be chosen freely.

**Example:**

The default values of the scaling block provides a scaling of:  
P1: 0.0 % = 0 mA  
P2: 100.0 % = 20 mA

**Dependency:**

Affects P2000 to P2002 (referency frequency, voltage, current) depending on which setpoint is to be generated.

**Note:**

The DAC-linear characteristic is described by 4 coordinates, based on a two-point equation:

$$\frac{y - P0778}{x - P0777} = \frac{P0780 - P0778}{P0779 - P0777}$$

For calculations the point-gradient form (offset and gradient) is more advantageous:

$$y = m \cdot x + y_0$$

The transformation between these two forms is given by:

$$m = \frac{P0780 - P0778}{P0779 - P0777} \quad y_0 = \frac{P0778 \cdot P0779 - P0777 \cdot P0780}{P0779 - P0777} \leq |200\%|$$

For scaling of the input the value of y\_max and x\_min has to be determined. This is done by the following equations:

$$x_{min} = \frac{P0780 \cdot P0777 - P0778 \cdot P0779}{P0780 - P0778}$$

$$y_{max} = (x_{max} - x_{min}) \cdot \frac{P0780 - P0778}{P0779 - P0777}$$

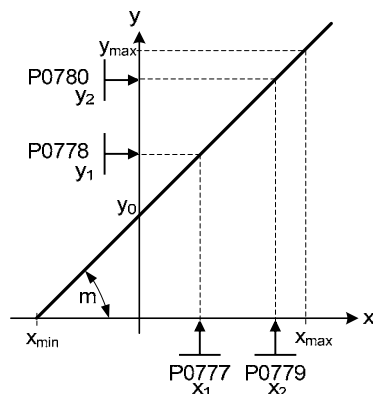

<b>P0778</b>	<b>Value y1 of DAC scaling</b>	<b>Min:</b> 0	<b>Level</b>
	<b>CStat:</b> CUT	<b>Datatype:</b> Float	<b>Def:</b> 0
	<b>P-Group:</b> TERMINAL	<b>Active:</b> first confirm	<b>QuickComm.:</b> No
		<b>Max:</b> 20	<b>2</b>

Defines y1 of output characteristic.

<b>P0779</b>	<b>Value x2 of DAC scaling</b>	<b>Min:</b> -99999.0	<b>Level</b>
	<b>CStat:</b> CUT	<b>Datatype:</b> Float	<b>Def:</b> 100.0
	<b>P-Group:</b> TERMINAL	<b>Active:</b> first confirm	<b>QuickComm.:</b> No
		<b>Max:</b> 99999.0	<b>2</b>

Defines x2 of output characteristic in [%].

**Dependency:**

Affects P2000 to P2002 (referency frequency, voltage, current) depending on which setpoint is to be generated.

<b>P0780</b>	<b>Value y2 of DAC scaling</b>	<b>Min:</b> 0	<b>Level</b>
	<b>CStat:</b> CUT	<b>Datatype:</b> Float	<b>Def:</b> 20
	<b>P-Group:</b> TERMINAL	<b>Active:</b> first confirm	<b>QuickComm.:</b> No
		<b>Max:</b> 20	<b>2</b>

Defines y2 of output characteristic.

<b>P0781</b>	<b>Width of DAC deadband</b>	<b>Min:</b> 0	<b>Level</b>
	<b>CStat:</b> CUT	<b>Datatype:</b> Float	<b>Def:</b> 0
	<b>P-Group:</b> TERMINAL	<b>Active:</b> first confirm	<b>QuickComm.:</b> No
		<b>Max:</b> 20	<b>2</b>

Sets width of dead-band in [mA] for analog output.

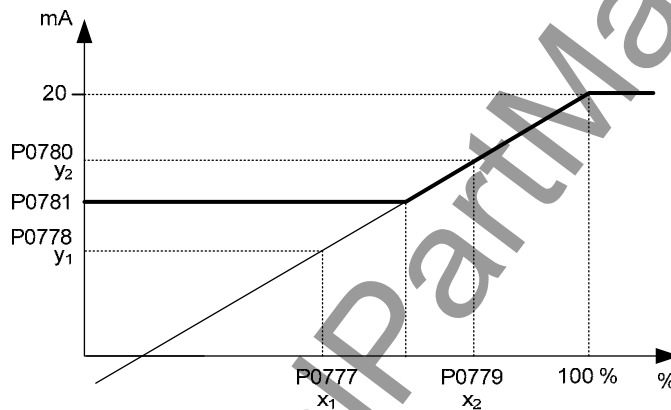

<b>r0785</b>	<b>CO/BO: Status word of DAC</b>	<b>Min:</b> -	<b>Level</b>
		<b>Datatype:</b> U16	<b>Def:</b> -
	<b>P-Group:</b> TERMINAL	<b>Unit:</b> -	<b>Max:</b> -
			<b>2</b>

Displays status of analog output. Bit 0 indicates that the value of analog output 1 is negative.

**Bitfields:**

Bit00 Analog output 1 -ve 0 NO 1 YES

### 3.10 BICO command parameters

<b>P0800</b>	<b>BI: Download parameter set 0</b>				<b>Min:</b> 0:0	<b>Level</b> <b>3</b>
	<b>CStat:</b> CT	<b>Datatype:</b> U32	<b>Unit:</b> -	<b>Def:</b> 0:0		
	<b>P-Group:</b> COMMANDS	<b>Active:</b> first confirm	<b>QuickComm.:</b> No	<b>Max:</b> 4000:0		

Defines source of command to start download of parameter set 0 from attached AOP.

**Common Settings:**

- 722.0 = Digital input 1 (requires P0701 to be set to 99, BICO)
- 722.1 = Digital input 2 (requires P0702 to be set to 99, BICO)
- 722.2 = Digital input 3 (requires P0703 to be set to 99, BICO)

**Dependency:**

1. The parameter set 0 can only be downloaded in conjunction with the AOP
2. Establish communications between the frequency inverter and AOP
3. The frequency inverter must be selected using the AOP if the AOP is connected at the COM link interface (RS485)
4. Select the frequency inverter state "Ready" (r0002 = 1)
5. Signal from P0800:
  - 0 = Do not download.
  - 1 = Start to download parameter set 0 from the AOP.

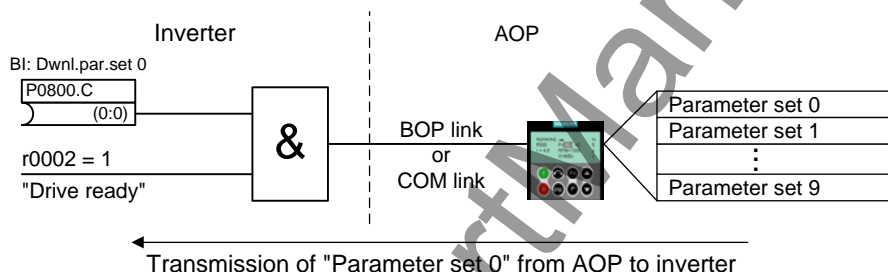

<b>P0801</b>	<b>BI: Download parameter set 1</b>				<b>Min:</b> 0:0	<b>Level</b> <b>3</b>
	<b>CStat:</b> CT	<b>Datatype:</b> U32	<b>Unit:</b> -	<b>Def:</b> 0:0		
	<b>P-Group:</b> COMMANDS	<b>Active:</b> first confirm	<b>QuickComm.:</b> No	<b>Max:</b> 4000:0		

Defines sources of command to start download of parameter set 1 from attached AOP.

**Common Settings:**

- 722.0 = Digital input 1 (requires P0701 to be set to 99, BICO)
- 722.1 = Digital input 2 (requires P0702 to be set to 99, BICO)
- 722.2 = Digital input 3 (requires P0703 to be set to 99, BICO)

**Note:**

See parameter P0800

<b>P0810</b>	<b>BI: CDS bit 0 (Local / Remote)</b>				<b>Min:</b> 0:0	<b>Level</b> <b>2</b>
	<b>CStat:</b> CUT	<b>Datatype:</b> U32	<b>Unit:</b> -	<b>Def:</b> 0:0		
	<b>P-Group:</b> COMMANDS	<b>Active:</b> first confirm	<b>QuickComm.:</b> No	<b>Max:</b> 4095:0		

Selects command source from which to read Bit 0 for selecting a command data set (CDS).

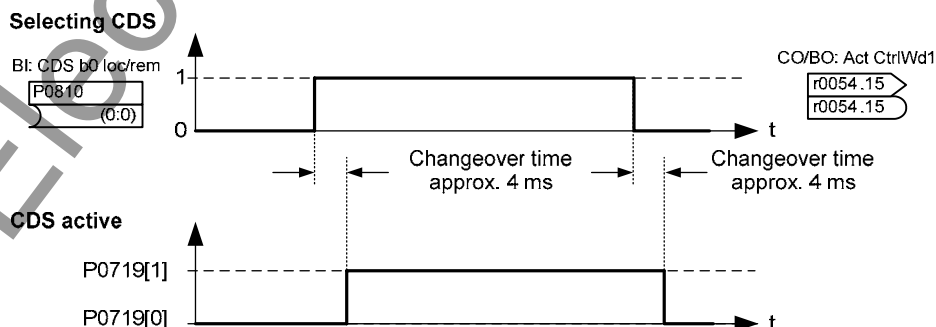

**Common Settings:**

- 722.0 = Digital input 1 (requires P0701 to be set to 99, BICO)
- 722.1 = Digital input 2 (requires P0702 to be set to 99, BICO)
- 722.2 = Digital input 3 (requires P0703 to be set to 99, BICO)
- 722.3 = Digital input 4 (via analog input, requires P0704 to be set to 99)

<b>P0840</b>	<b>BI: ON/OFF1</b>			<b>Min:</b> 0:0	<b>Level</b> <b>3</b>
	<b>CStat:</b> CT	<b>Datatype:</b> U32	<b>Unit:</b> -	<b>Def:</b> 722:0	
	<b>P-Group:</b> COMMANDS	<b>Active:</b> first confirm	<b>QuickComm.:</b> No	<b>Max:</b> 4000:0	

Allows ON/OFF1 command source to be selected using BICO.

The first three digits describe the parameter number of the command source; the last digit denotes the bit setting for that parameter. The default setting (ON right) is digital input 1 (722.0). Alternative source possible only when function of digital input 1 is changed (via P0701) before changing value of P0840.

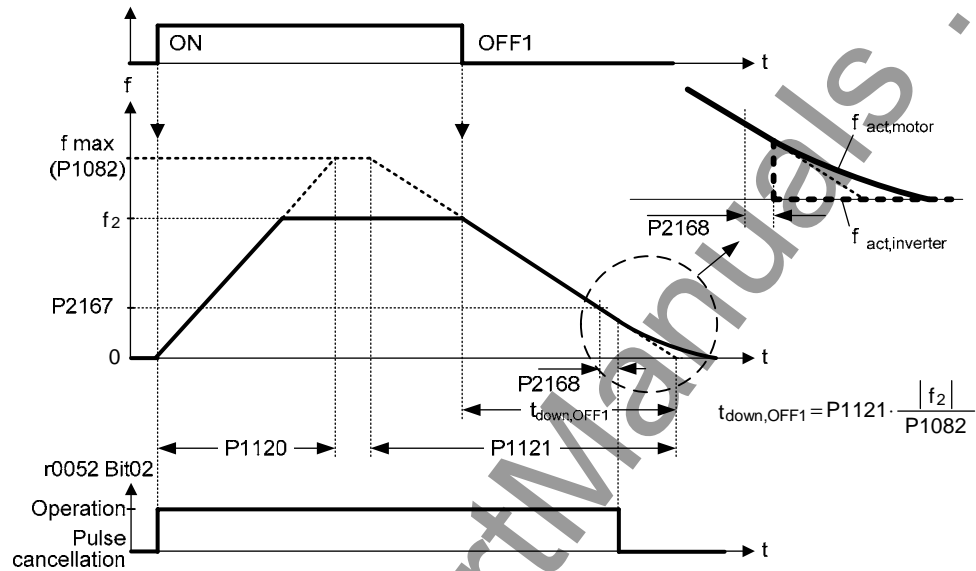

**Common Settings:**

- 722.0 = Digital input 1 (requires P0701 to be set to 99, BICO)
- 722.1 = Digital input 2 (requires P0702 to be set to 99, BICO)
- 722.2 = Digital input 3 (requires P0703 to be set to 99, BICO)
- 722.3 = Digital input 4 (via analog input, requires P0704 to be set to 99)
- 19.0 = ON/OFF1 via BOP

**Dependency:**

Active only when P0719 < 10. See parameter P0719 (Selection of command/setpoint source).

**Note:**

- OFF1 means a ramp stop down to 0 using P1121.
- OFF1 is low active.
- For the priority of all soft commands, the following applies: OFF2, OFF3, OFF1

<b>P0842</b>	<b>BI: ON reverse/OFF1</b>			<b>Min:</b> 0:0	<b>Level</b> <b>3</b>
	<b>CStat:</b> CT	<b>Datatype:</b> U32	<b>Unit:</b> -	<b>Def:</b> 0:0	
	<b>P-Group:</b> COMMANDS	<b>Active:</b> first confirm	<b>QuickComm.:</b> No	<b>Max:</b> 4000:0	

Allows ON/OFF1 reverse command source to be selected using BICO.

Normally in this case at a positive frequency setpoint, it is getting approached ccw (negative frequency setpoint) The first three digits describe the parameter number of the command source and the last digit denotes the bit setting for that parameter.

**Common Settings:**

- 722.0 = Digital input 1 (requires P0701 to be set to 99, BICO)
- 722.1 = Digital input 2 (requires P0702 to be set to 99, BICO)
- 722.2 = Digital input 3 (requires P0703 to be set to 99, BICO)
- 722.3 = Digital input 4 (via analog input, requires P0704 to be set to 99)
- 19.0 = ON/OFF1 via BOP

**Details:**

See parameter P0840.

<b>P0844</b>	<b>BI: 1. OFF2</b>			<b>Min:</b> 0:0	<b>Level 3</b>
	<b>CStat:</b> CT	<b>Datatype:</b> U32	<b>Unit:</b> -	<b>Def:</b> 1:0	
	<b>P-Group:</b> COMMANDS	<b>Active:</b> first confirm	<b>QuickComm.:</b> No	<b>Max:</b> 4000:0	

Defines first source of OFF2.

The first three digits describe the parameter number of the command source and the last digit denotes the bit setting for that parameter. If one of the digital inputs is selected for OFF2, the inverter will not run unless the digital input is active.

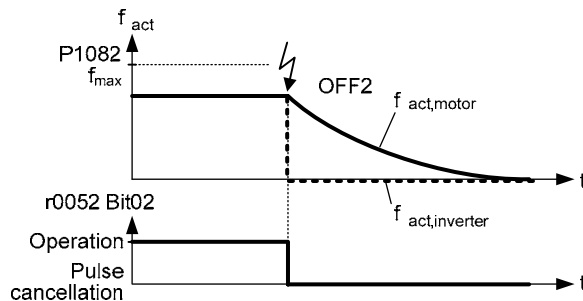

**Common Settings:**

- 722.0 = Digital input 1 (requires P0701 to be set to 99, BICO)
- 722.1 = Digital input 2 (requires P0702 to be set to 99, BICO)
- 722.2 = Digital input 3 (requires P0703 to be set to 99, BICO)
- 722.3 = Digital input 4 (via analog input, requires P0704 to be set to 99)
- 19.0 = ON/OFF1 via BOP
- 19.1 = OFF2: Electrical stop via BOP

**Dependency:**

Active only when P0719 < 10. See parameter P0719 (Selection of command/setpoint source).

**Note:**

- OFF2 means an immediate pulse inhibit; the motor coasts down.
- OFF2 is low active.
- The following applies for the priority of all of the OFF commands: OFF2, OFF3, OFF1

<b>P0845</b>	<b>BI: 2. OFF2</b>			<b>Min:</b> 0:0	<b>Level 3</b>
	<b>CStat:</b> CT	<b>Datatype:</b> U32	<b>Unit:</b> -	<b>Def:</b> 19:1	
	<b>P-Group:</b> COMMANDS	<b>Active:</b> first confirm	<b>QuickComm.:</b> No	<b>Max:</b> 4000:0	

Defines second source of OFF2.

The first three digits describe the parameter number of the command source and the last digit denotes the bit setting for that parameter. If one of the digital inputs is selected for OFF2, the inverter will not run unless the digital input is active.

**Common Settings:**

- 722.0 = Digital input 1 (requires P0701 to be set to 99, BICO)
- 722.1 = Digital input 2 (requires P0702 to be set to 99, BICO)
- 722.2 = Digital input 3 (requires P0703 to be set to 99, BICO)
- 722.3 = Digital input 4 (via analog input, requires P0704 to be set to 99)
- 19.0 = ON/OFF1 via BOP

**Details:**

See parameter P0844.

<b>P0848</b>	<b>BI: 1. OFF3</b>			<b>Min:</b> 0:0	<b>Level</b> <b>3</b>
	<b>CStat:</b> CT	<b>Datatype:</b> U32	<b>Unit:</b> -	<b>Def:</b> 1:0	
	<b>P-Group:</b> COMMANDS	<b>Active:</b> first confirm	<b>QuickComm.:</b> No	<b>Max:</b> 4000:0	

Defines first source of OFF3.

The first three digits describe the parameter number of the command source and the last digit denotes the bit setting for that parameter. If one of the digital inputs is selected for OFF3, the inverter will not run unless the digital input is active.

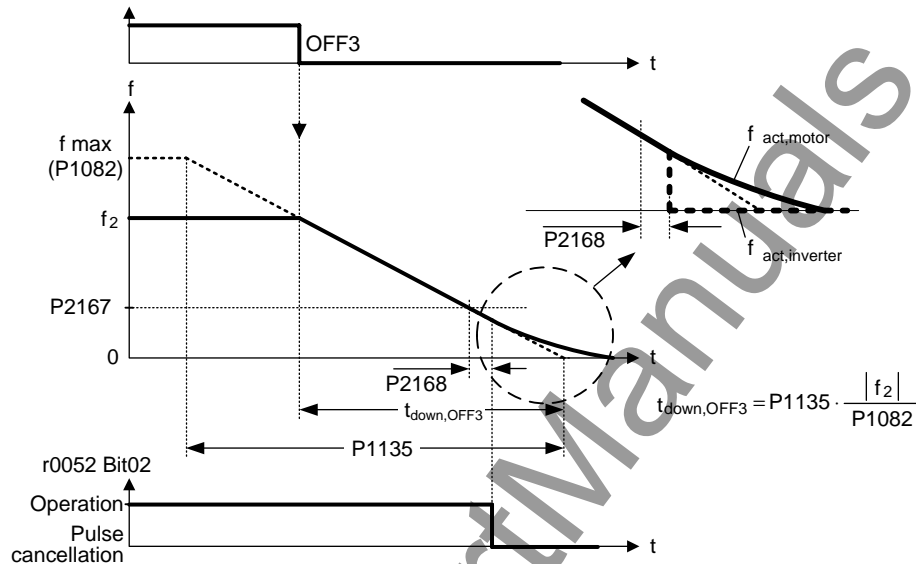

**Common Settings:**

- 722.0 = Digital input 1 (requires P0701 to be set to 99, BICO)
- 722.1 = Digital input 2 (requires P0702 to be set to 99, BICO)
- 722.2 = Digital input 3 (requires P0703 to be set to 99, BICO)
- 722.3 = Digital input 4 (via analog input, requires P0704 to be set to 99)
- 19.0 = ON/OFF1 via BOP

**Dependency:**

Active only when P0719 < 10. See parameter P0719 (Selection of command/setpoint source).

**Note:**

- OFF3 means fast ramp-down to 0 Hz through P1135.
- OFF3 is low-active.
- Priority of all OFF commands: OFF2, OFF3, OFF1

<b>P0849</b>	<b>BI: 2. OFF3</b>			<b>Min:</b> 0:0	<b>Level</b> <b>3</b>
	<b>CStat:</b> CT	<b>Datatype:</b> U32	<b>Unit:</b> -	<b>Def:</b> 1:0	
	<b>P-Group:</b> COMMANDS	<b>Active:</b> first confirm	<b>QuickComm.:</b> No	<b>Max:</b> 4000:0	

Defines second source of OFF3.

The first three digits describe the parameter number of the command source and the last digit denotes the bit setting for that parameter. If one of the digital inputs is selected for OFF3, the inverter will not run unless the digital input is active.

**Common Settings:**

- 722.0 = Digital input 1 (requires P0701 to be set to 99, BICO)
- 722.1 = Digital input 2 (requires P0702 to be set to 99, BICO)
- 722.2 = Digital input 3 (requires P0703 to be set to 99, BICO)
- 722.3 = Digital input 4 (via analog input, requires P0704 to be set to 99)
- 19.0 = ON/OFF1 via BOP

**Dependency:**

In contrast to P0848 (first source of OFF3), this parameter is always active, independent of P0719 (selection of command and frequency setpoint).

**Details:**

See parameter P0848.

<b>P0852</b>	<b>BI: Pulse enabling</b>			<b>Min:</b> 0:0	Level <b>3</b>
	<b>CStat:</b> CT	<b>Datatype:</b> U32	<b>Unit:</b> -	<b>Def:</b> 1:0	
	<b>P-Group:</b> COMMANDS	<b>Active:</b> first confirm	<b>QuickComm.:</b> No	<b>Max:</b> 4000:0	

Defines source of pulse enable/disable signal.

**Common Settings:**

- 722.0 = Digital input 1 (requires P0701 to be set to 99, BICO)
- 722.1 = Digital input 2 (requires P0702 to be set to 99, BICO)
- 722.2 = Digital input 3 (requires P0703 to be set to 99, BICO)
- 722.3 = Digital input 4 (via analog input, requires P0704 to be set to 99)

**Dependency:**

Active only when P0719 < 10. See parameter P0719 (Selection of command/setpoint source).

### 3.11 Communication parameters

<b>P0918</b>	<b>CB address</b>			<b>Min:</b> 0	Level <b>2</b>
	<b>CStat:</b> CT	<b>Datatype:</b> U16	<b>Unit:</b> -	<b>Def:</b> 3	
	<b>P-Group:</b> COMM	<b>Active:</b> first confirm	<b>QuickComm.:</b> No	<b>Max:</b> 65535	

Defines address of CB (communication board) or address of the other option modules.

There are two ways to set the bus address:

- via DIP switches on the PROFIBUS module
- via a user-entered value

**Note:**

Possible PROFIBUS settings:

- 1 ... 125
- 0, 126, 127 are not allowed

The following applies when a PROFIBUS module is used:

- DIP switch = 0 Address defined in P0918 (CB address) is valid
- DIP switch not = 0 DIP switch setting has priority and P0918 indicates DIP switch setting.

<b>P0927</b>	<b>Parameter changeable via</b>			<b>Min:</b> 0	Level <b>2</b>
	<b>CStat:</b> CUT	<b>Datatype:</b> U16	<b>Unit:</b> -	<b>Def:</b> 15	
	<b>P-Group:</b> COMM	<b>Active:</b> first confirm	<b>QuickComm.:</b> No	<b>Max:</b> 15	

Specifies the interfaces which can be used to change parameters.

This parameter allows the user to easily protect the inverter from unauthorized modification of parameters. Annotation: Parameter P0927 is not password protected.

**Bitfields:**

Bit00	PROFIBUS / CB	0	NO	1	YES
Bit01	BOP	0	NO	1	YES
Bit02	USS on BOP link	0	NO	1	YES
Bit03	USS on COM link	0	NO	1	YES

**Example:**

Bits 0, 1, 2 and 3 set:

The default setting allows parameters to be changed via any interface. If all bits are set, the parameter is displayed on BOP as follows:

BOP:  
P0927

Bits 0, 1, 2 and 3 reset:

This setting allows no parameters to be modified via any interface with the exception of P0003 and P0927. If all bits are reset, the parameter is displayed on BOP as follows:

BOP:  
P0927

**Details:**

The seven-segment display is explained in the "Introduction to MICROMASTER System Parameters" in this handbook.

<b>r0947[8]</b>	<b>CO: Last fault code</b>			<b>Min:</b> -	Level <b>2</b>
		<b>Datatype:</b> U16	<b>Unit:</b> -	<b>Def:</b> -	
	<b>P-Group:</b> ALARMS			<b>Max:</b> -	

Displays fault history according to the diagram below

where:

- "F1" is the first active fault (not yet acknowledged).
- "F2" is the second active fault (not yet acknowledged).
- "F1e" is the occurrence of the fault acknowledgement for F1 & F2.

This moves the value in the 2 indices down to the next pair of indices, where they are stored. Indices 0 & 1 contain the active faults. When faults are acknowledged, indices 0 & 1 are reset to 0.

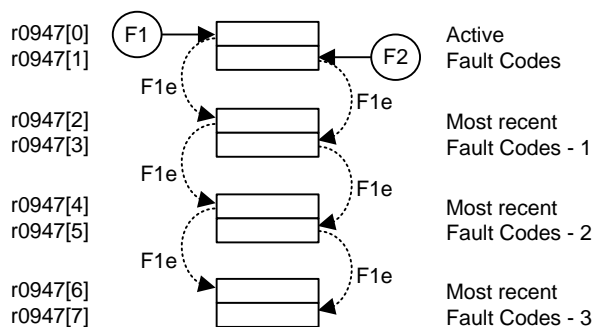

**Index:**

- r0947[0] : Recent fault trip --, fault 1
- r0947[1] : Recent fault trip --, fault 2
- r0947[2] : Recent fault trip -1, fault 3
- r0947[3] : Recent fault trip -1, fault 4
- r0947[4] : Recent fault trip -2, fault 5
- r0947[5] : Recent fault trip -2, fault 6
- r0947[6] : Recent fault trip -3, fault 7
- r0947[7] : Recent fault trip -3, fault 8

**Example:**

If the inverter trips on undervoltage and then receives an external trip before the undervoltage is acknowledged, you will obtain:

- r0947[0] = 3 Undervoltage (F0003)
- r0947[1] = 85 External trip (F0085)

Whenever a fault in index 0 is acknowledged (F1e), the fault history shifts as indicated in the diagram above.

**Dependency:**

Index 1 used only if second fault occurs before first fault is acknowledged.

**Details:**

See "Faults and Warnings"

<b>r0948[12]</b>	<b>CO: Fault time</b>	<b>Datatype:</b> U16	<b>Unit:</b> -	<b>Min:</b> - <b>Def:</b> - <b>Max:</b> -	<b>Level</b> <b>3</b>
	<b>P-Group:</b> ALARMS				

Time stamp to indicate when the fault has occurred.

**Index:**

- r0948[0] : Recent fault trip --, time stamp
- r0948[1] : Recent fault trip --, time stamp
- r0948[2] : Recent fault trip --, time stamp
- r0948[3] : Recent fault trip -1, time stamp
- r0948[4] : Recent fault trip -1, time stamp
- r0948[5] : Recent fault trip -1, time stamp
- r0948[6] : Recent fault trip -2, time stamp
- r0948[7] : Recent fault trip -2, time stamp
- r0948[8] : Recent fault trip -2, time stamp
- r0948[9] : Recent fault trip -3, time stamp
- r0948[10] : Recent fault trip -3, time stamp
- r0948[11] : Recent fault trip -3, time stamp

**Details:**

Parameter r2114 (runtime counter) is a possible source of the time stamp. When using the runtime counter, the time is entered into the first two indices of the fault trip (shutdown) essentially the same as for r2114.

Time stamp when using r2114 (Refer to parameter r2114):

- r0948[0] : Last fault trip --, system time, seconds, upper word
- r0948[1] : Last fault trip --, system time, seconds, lower word
- r0948[2] : 0
- r0948[3] : Last fault trip --, system time, seconds, upper word
- r0948[4] : Last fault trip --, system time, seconds, lower word
- r0948[5] : 0
- r0948[6] : Last fault trip --, system time, seconds, upper word
- r0948[7] : Last fault trip --, system time, seconds, lower word
- r0948[8] : 0
- r0948[9] : Last fault trip --, system time, seconds, upper word
- r0948[10] : Last fault trip --, system time, seconds, lower word
- r0948[11] : 0

Parameter P2115 (AOP real-time clock) is an additional possible source of the time stamp. When using the real-time counter, instead of the system runtime r2114[0] and r2114[1], the value of the real-time clock P2115[0] to P2115[2] is read-in.

If the contents of parameter P2115 = 0, then the system assumes that there was no synchronization with the real time. In this case, if there is a fault, values are transferred from parameter r2114 into parameter P0948. If the contents of parameter P2115 are not equal to zero, then a synchronization with real time has taken place. In this case, if there is a fault, the values from parameter P2115 are transferred into parameter P0948.

Time stamp when using P2115 (Refer to parameter P2115 (AOP real-time clock)):

- r0948[0] : Last fault trip --, fault time, seconds + minutes
- r0948[1] : Last fault trip --, fault time, hours + days
- r0948[2] : Last fault trip --, fault time, month + year
- r0948[3] : Last fault trip -1, fault time, seconds + minutes
- r0948[4] : Last fault trip -1, fault time, hours + days
- r0948[5] : Last fault trip -1, fault time, month + year
- r0948[6] : Last fault trip -2, fault time, seconds + minutes
- r0948[7] : Last fault trip -2, fault time, hours + days
- r0948[8] : Last fault trip -2, fault time, month + year
- r0948[9] : Last fault trip -3, fault time, seconds + minutes
- r0948[10] : Last fault trip -3, fault time, hours + days
- r0948[11] : Last fault trip -3, fault time, month + year

<b>r0949[8]</b>	<b>CO: Fault value</b>	<b>Datatype:</b> U16	<b>Unit:</b> -	<b>Min:</b> - <b>Def:</b> - <b>Max:</b> -	<b>Level</b> <b>3</b>
	<b>P-Group:</b> ALARMS				

Displays drive fault values. It is for service purposes and indicate the type of fault reported. The values are listed in the code where faults are reported.

**Index:**

- r0949[0] : Recent fault trip --, fault value 1
- r0949[1] : Recent fault trip --, fault value 2
- r0949[2] : Recent fault trip -1, fault value 3
- r0949[3] : Recent fault trip -1, fault value 4
- r0949[4] : Recent fault trip -2, fault value 5
- r0949[5] : Recent fault trip -2, fault value 6
- r0949[6] : Recent fault trip -3, fault value 7
- r0949[7] : Recent fault trip -3, fault value 8

<b>P0952</b>	<b>Total number of faults</b>	<b>Datatype:</b> U16	<b>Unit:</b> -	<b>Min:</b> 0	Level <b>3</b>
	<b>CStat:</b> CUT	<b>Active:</b> first confirm	<b>QuickComm.:</b> No	<b>Def:</b> 0	
	<b>P-Group:</b> ALARMS			<b>Max:</b> 8	

Displays number of faults stored in r0947 (last fault code).

**Dependency:**

Setting 0 resets fault history. (changing to 0 also resets parameter r0948 - fault time).

<b>r0964[5]</b>	<b>Firmware version data</b>	<b>Datatype:</b> U16	<b>Unit:</b> -	<b>Min:</b> -	Level <b>3</b>
	<b>P-Group:</b> COMM			<b>Def:</b> -	
				<b>Max:</b> -	

Firmware version data.

**Index:**

r0964[0] : Company (Siemens = 42)  
 r0964[1] : Product type  
 r0964[2] : Firmware version  
 r0964[3] : Firmware date (year)  
 r0964[4] : Firmware date (day/month)

**Example:**

No.	Value	Meaning
r0964[0]	42	SIEMENS
r0964[1]	1001	MICROMASTER 420
	1002	MICROMASTER 440
	1003	MICRO- / COMBIMASTER 411
	1004	MICROMASTER 410
	1005	reserved
	1006	MICROMASTER 440 PX
	1007	MICROMASTER 430
r0964[2]	105	Firmware V1.05
r0964[3]	2001	27.10.2001
r0964[4]	2710	

<b>r0965</b>	<b>Profibus profile</b>	<b>Datatype:</b> U16	<b>Unit:</b> -	<b>Min:</b> -	Level <b>3</b>
	<b>P-Group:</b> COMM			<b>Def:</b> -	
				<b>Max:</b> -	

Identification of profile number and version for PROFIDrive.

<b>r0967</b>	<b>Control word 1</b>	<b>Datatype:</b> U16	<b>Unit:</b> -	<b>Min:</b> -	Level <b>3</b>
	<b>P-Group:</b> COMM			<b>Def:</b> -	
				<b>Max:</b> -	

Displays control word 1.

**Bitfields:**

Bit00	ON/OFF1	0	NO	1	YES
Bit01	OFF2: Electrical stop	0	YES	1	NO
Bit02	OFF3: Fast stop	0	YES	1	NO
Bit03	Pulses enabled	0	NO	1	YES
Bit04	RFG enable	0	NO	1	YES
Bit05	RFG start	0	NO	1	YES
Bit06	Setpoint enable	0	NO	1	YES
Bit07	Fault acknowledge	0	NO	1	YES
Bit08	JOG right	0	NO	1	YES
Bit09	JOG left	0	NO	1	YES
Bit10	Control from PLC	0	NO	1	YES
Bit11	Reverse (setpoint inversion)	0	NO	1	YES
Bit13	Motor potentiometer MOP up	0	NO	1	YES
Bit14	Motor potentiometer MOP down	0	NO	1	YES
Bit15	Local / Remote	0	NO	1	YES

<b>r0968</b>	<b>Status word 1</b>	<b>Datatype:</b> U16	<b>Unit:</b> -	<b>Min:</b> -	<b>Def:</b> -	<b>Max:</b> -	<b>Level</b>
	<b>P-Group:</b> COMM						<b>3</b>

Displays active status word of inverter (in binary) and can be used to diagnose which commands are active.

**Bitfields:**

Bit00	Drive ready	0	NO	1	YES
Bit01	Drive ready to run	0	NO	1	YES
Bit02	Drive running	0	NO	1	YES
Bit03	Drive fault active	0	NO	1	YES
Bit04	OFF2 active	0	YES	1	NO
Bit05	OFF3 active	0	YES	1	NO
Bit06	ON inhibit active	0	NO	1	YES
Bit07	Drive warning active	0	NO	1	YES
Bit08	Deviation setpoint / act. value	0	YES	1	NO
Bit09	PZD control	0	NO	1	YES
Bit10	Maximum frequency reached	0	NO	1	YES
Bit11	Warning: Motor current limit	0	YES	1	NO
Bit12	Motor holding brake active	0	NO	1	YES
Bit13	Motor overload	0	YES	1	NO
Bit14	Motor runs right	0	NO	1	YES
Bit15	Inverter overload	0	YES	1	NO

<b>P0970</b>	<b>Factory reset</b>	<b>Datatype:</b> U16	<b>Unit:</b> -	<b>Min:</b> 0	<b>Def:</b> 0	<b>Max:</b> 1	<b>Level</b>
	<b>CStat:</b> C	<b>Active:</b> first confirm	<b>QuickComm.:</b> No				<b>1</b>

P0970 = 1 resets all parameters to their default values.

**Possible Settings:**

- 0 Disabled
- 1 Parameter reset

**Dependency:**

- First set P0010 = 30 (factory settings).
- Stop drive (i.e. disable all pulses) before you can reset parameters to default values.

**Note:**

The following parameters retain their values after a factory reset:

- P0014 Store mode
- r0039 CO: Energy consumption meter [kWh]
- P0100 Europe / North America
- P0918 CB address
- P2010 USS baud rate
- P2011 USS address

<b>P0971</b>	<b>Transfer data from RAM to EEPROM</b>	<b>Datatype:</b> U16	<b>Unit:</b> -	<b>Min:</b> 0	<b>Def:</b> 0	<b>Max:</b> 1	<b>Level</b>
	<b>CStat:</b> CUT	<b>Active:</b> first confirm	<b>QuickComm.:</b> No				<b>3</b>

Transfers values from RAM to EEPROM when set to 1.

**Possible Settings:**

- 0 Disabled
- 1 Start transfer

**Note:**

All values in RAM are transferred to EEPROM.

Parameter is automatically reset to 0 (default) after successful transfer.

The storage from RAM to EEPROM is accomplished via P0971. The communications are reset, if the transfer was successful. During the reset process communications will be interrupted. This creates the following conditions:

- PLC (e.g. SIMATIC S7) enters Stop mode
- Starter automatically recovers communications once they are re-established.
- Drivemonitor is displayed "NC" (not connected) in the status line or "drive busy".
- BOP displays "busy"

After completion of the transfer process, the communication between the inverter and the PC-tools (e.g. Starter) or BOP is automatically re-established.

### 3.12 Setpoint source

<b>P1000</b>	<b>Selection of frequency setpoint</b>				<b>Min:</b> 0	<b>Level</b> <b>1</b>
	<b>CStat:</b> CT	<b>Datatype:</b> U16	<b>Unit:</b> -	<b>Def:</b> 2		
	<b>P-Group:</b> SETPOINT	<b>Active:</b> first confirm	<b>QuickComm.:</b> Yes	<b>Max:</b> 66		

Selects frequency setpoint source.

The selection of settings is detailed in the following table of possible settings, in which the Main setpoint is given by the least significant digit (right-hand position) and the Additional setpoint is given by the most significant digit (left-hand position).

**Possible Settings:**

0	No main setpoint	
1	MOP setpoint	
2	Analog setpoint	
3	Fixed frequency	
4	USS on BOP link	
5	USS on COM link	
6	CB on COM link	
10	No main setpoint	+ MOP setpoint
11	MOP setpoint	+ MOP setpoint
12	Analog setpoint	+ MOP setpoint
13	Fixed frequency	+ MOP setpoint
14	USS on BOP link	+ MOP setpoint
15	USS on COM link	+ MOP setpoint
16	CB on COM link	+ MOP setpoint
20	No main setpoint	+ Analog setpoint
21	MOP setpoint	+ Analog setpoint
22	Analog setpoint	+ Analog setpoint
23	Fixed frequency	+ Analog setpoint
24	USS on BOP link	+ Analog setpoint
25	USS on COM link	+ Analog setpoint
26	CB on COM link	+ Analog setpoint
30	No main setpoint	+ Fixed frequency
31	MOP setpoint	+ Fixed frequency
32	Analog setpoint	+ Fixed frequency
33	Fixed frequency	+ Fixed frequency
34	USS on BOP link	+ Fixed frequency
35	USS on COM link	+ Fixed frequency
36	CB on COM link	+ Fixed frequency
40	No main setpoint	+ USS on BOP link
41	MOP setpoint	+ USS on BOP link
42	Analog setpoint	+ USS on BOP link
43	Fixed frequency	+ USS on BOP link
44	USS on BOP link	+ USS on BOP link
45	USS on COM link	+ USS on BOP link
46	CB on COM link	+ USS on BOP link
50	No main setpoint	+ USS on COM link
51	MOP setpoint	+ USS on COM link
52	Analog setpoint	+ USS on COM link
53	Fixed frequency	+ USS on COM link
54	USS on BOP link	+ USS on COM link
55	USS on COM link	+ USS on COM link
60	No main setpoint	+ CB on COM link
61	MOP setpoint	+ CB on COM link
62	Analog setpoint	+ CB on COM link
63	Fixed frequency	+ CB on COM link
64	USS on BOP link	+ CB on COM link
66	CB on COM link	+ CB on COM link

**Example:**

Setting 12 selects main setpoint (2) derived from analog input with additional setpoint (1) taken from the motor potentiometer.

Example P1000 = 12 :

P1000 = 12    P1075 = 1050	P1075 CI: Additional setpoint
	r1050 CO: Act. Output freq. of the MOP
P1000 = 12    P1070 = 755	P1070 CI: Main setpoint
	r0755 CO: Act. ADC after scal. [4000h]

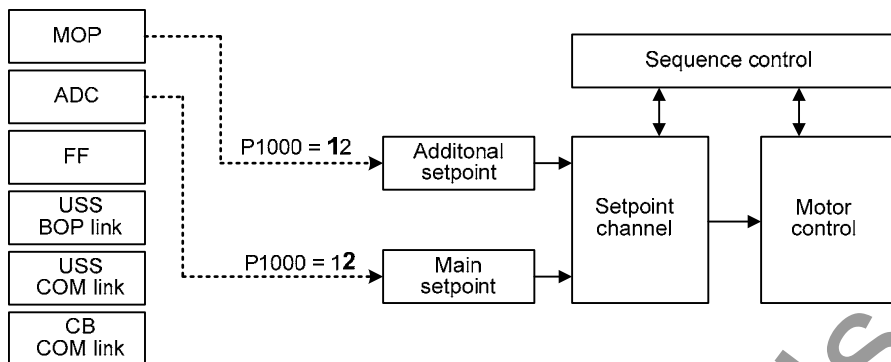

**Caution:** Be aware, by changing of parameter P1000 all BICO parameters (see table below) are modified.

**Note:** Single digits denote main setpoints that have no additional setpoint.

Changing this parameter sets (to default) all settings on item selected (see table).

		P1000 = xy							
		y = 0	y = 1	y = 2	y = 3	y = 4	y = 5	y = 6	
x = 0	0.0	1050.0	755.0	1024.0	2015.1	2018.1	2050.1	P1070	
	1.0	1.0	1.0	1.0	1.0	1.0	1.0	P1071	
	0.0	0.0	0.0	0.0	0.0	0.0	0.0	P1075	
	1.0	1.0	1.0	1.0	1.0	1.0	1.0	P1076	
x = 1	0.0	1050.0	755.0	1024.0	2015.1	2018.1	2050.1	P1070	
	1.0	1.0	1.0	1.0	1.0	1.0	1.0	P1071	
	1050.0	1050.0	1050.0	1050.0	1050.0	1050.0	1050.0	P1075	
	1.0	1.0	1.0	1.0	1.0	1.0	1.0	P1076	
x = 2	0.0	1050.0	755.0	1024.0	2015.1	2018.1	2050.1	P1070	
	1.0	1.0	1.0	1.0	1.0	1.0	1.0	P1071	
	755.0	755.0	755.0	755.0	755.0	755.0	755.0	P1075	
	1.0	1.0	1.0	1.0	1.0	1.0	1.0	P1076	
x = 3	0.0	1050.0	755.0	1024.0	2015.1	2018.1	2050.1	P1070	
	1.0	1.0	1.0	1.0	1.0	1.0	1.0	P1071	
	1024.0	1024.0	1024.0	1024.0	1024.0	1024.0	1024.0	P1075	
	1.0	1.0	1.0	1.0	1.0	1.0	1.0	P1076	
x = 4	0.0	1050.0	755.0	1024.0	2015.1	2018.1	2050.1	P1070	
	1.0	1.0	1.0	1.0	1.0	1.0	1.0	P1071	
	2015.1	2015.1	2015.1	2015.1	2015.1	2015.1	2015.1	P1075	
	1.0	1.0	1.0	1.0	1.0	1.0	1.0	P1076	
x = 5	0.0	1050.0	755.0	1024.0	2015.1	2018.1		P1070	
	1.0	1.0	1.0	1.0	1.0	1.0		P1071	
	2018.1	2018.1	2018.1	2018.1	2018.1	2018.1		P1075	
	1.0	1.0	1.0	1.0	1.0	1.0		P1076	
x = 6	0.0	1050.0	755.0	1024.0	2015.1		2050.1	P1070	
	1.0	1.0	1.0	1.0	1.0		1.0	P1071	
	2050.1	2050.1	2050.1	2050.1	2050.1		2050.1	P1075	
	1.0	1.0	1.0	1.0	1.0		1.0	P1076	

**Example:**

P1000 = 21 → P1070 = 1050.0  
 P1071 = 1.0  
 P1075 = 755.0  
 P1076 = 1.0

### 3.13 Fixed frequencies

<b>P1001</b>	<b>Fixed frequency 1</b>	<b>Datatype:</b> Float	<b>Unit:</b> Hz	<b>Min:</b> -650.00	<b>Level</b> <b>2</b>
	<b>CStat:</b> CUT	<b>Active:</b> Immediately	<b>QuickComm.:</b> No	<b>Def:</b> 0.00	
	<b>P-Group:</b> SETPOINT			<b>Max:</b> 650.00	

Defines fixed frequency setpoint 1.

There are three options available for selection of the fixed frequencies:

1. Direct selection
  2. Direct selection + ON command
  3. Binary coded selection + ON command
1. Direct selection (P0701 - P0703 = 15):
    - In this mode of operation 1 digital input selects 1 fixed frequency.
    - If several inputs are active together, the selected frequencies are summed.
    - E.g.: FF1 + FF2 + FF3.
  2. Direct selection + ON command (P0701 - P0703 = 16):
    - The fixed frequency selection combines the fixed frequencies with an ON command.
    - In this mode of operation 1 digital input selects 1 fixed frequency.
    - If several inputs are active together, the selected frequencies are summed.
    - E.g.: FF1 + FF2 + FF3.
  3. Binary coded selection + ON command (P0701 - P0703 = 17):
    - Up to 7 fixed frequencies can be selected using this method.
    - The fixed frequencies are selected according to the following table:

**Example:**

Binary coded selection :

		DIN3	DIN2	DIN1
0 Hz	FF0	0	0	0
P1001	FF1	0	0	1
P1002	FF2	0	1	0
P1003	FF3	0	1	1
P1004	FF4	1	0	0
P1005	FF5	1	0	1
P1006	FF6	1	1	0
P1007	FF7	1	1	1

Direct selection of FF P1001 via DIN 1:

P0701 = 15 or P0701 = 99, P1020 = 722.0, P1016 = 1  
 P0702 = 15 or P0702 = 99, P1021 = 722.1, P1017 = 1

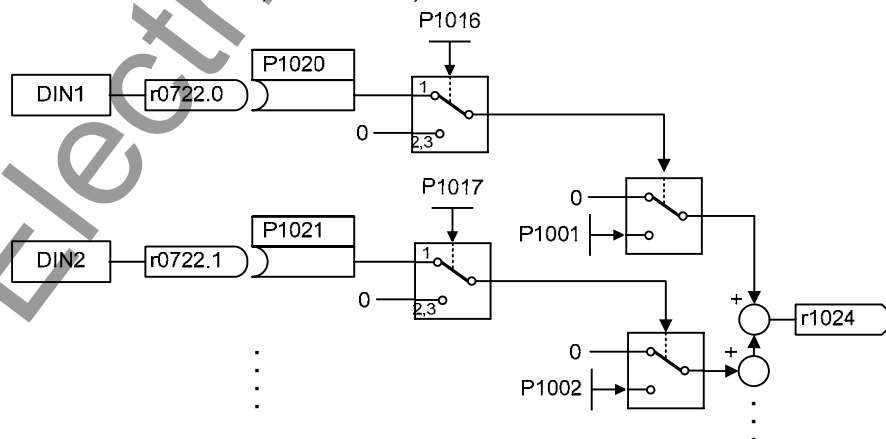

**Dependency:**

Select fixed frequency operation (using P1000).

Inverter requires ON command to start in the case of direct selection (P0701 - P0703 = 15).

**Note:**

Fixed frequencies can be selected using the digital inputs, and can also be combined with an ON command.

<b>P1002</b>	<b>Fixed frequency 2</b>	<b>CStat:</b> CUT	<b>Datatype:</b> Float	<b>Unit:</b> Hz	<b>Min:</b> -650.00	<b>Def:</b> 5.00	<b>Level</b>
	<b>P-Group:</b> SETPOINT	<b>Active:</b> Immediately	<b>QuickComm.:</b> No	<b>Max:</b> 650.00	<b>2</b>		
	Defines fixed frequency setpoint 2.						
<b>Details:</b>	See parameter P1001 (fixed frequency 1).						
<b>P1003</b>	<b>Fixed frequency 3</b>	<b>CStat:</b> CUT	<b>Datatype:</b> Float	<b>Unit:</b> Hz	<b>Min:</b> -650.00	<b>Def:</b> 10.00	<b>Level</b>
	<b>P-Group:</b> SETPOINT	<b>Active:</b> Immediately	<b>QuickComm.:</b> No	<b>Max:</b> 650.00	<b>2</b>		
	Defines fixed frequency setpoint 3.						
<b>Details:</b>	See parameter P1001 (fixed frequency 1).						
<b>P1004</b>	<b>Fixed frequency 4</b>	<b>CStat:</b> CUT	<b>Datatype:</b> Float	<b>Unit:</b> Hz	<b>Min:</b> -650.00	<b>Def:</b> 15.00	<b>Level</b>
	<b>P-Group:</b> SETPOINT	<b>Active:</b> Immediately	<b>QuickComm.:</b> No	<b>Max:</b> 650.00	<b>2</b>		
	Defines fixed frequency setpoint 4.						
<b>Details:</b>	See parameter P1001 (fixed frequency 1).						
<b>P1005</b>	<b>Fixed frequency 5</b>	<b>CStat:</b> CUT	<b>Datatype:</b> Float	<b>Unit:</b> Hz	<b>Min:</b> -650.00	<b>Def:</b> 20.00	<b>Level</b>
	<b>P-Group:</b> SETPOINT	<b>Active:</b> Immediately	<b>QuickComm.:</b> No	<b>Max:</b> 650.00	<b>2</b>		
	Defines fixed frequency setpoint 5.						
<b>Details:</b>	See parameter P1001 (fixed frequency 1).						
<b>P1006</b>	<b>Fixed frequency 6</b>	<b>CStat:</b> CUT	<b>Datatype:</b> Float	<b>Unit:</b> Hz	<b>Min:</b> -650.00	<b>Def:</b> 25.00	<b>Level</b>
	<b>P-Group:</b> SETPOINT	<b>Active:</b> Immediately	<b>QuickComm.:</b> No	<b>Max:</b> 650.00	<b>2</b>		
	Defines fixed frequency setpoint 6.						
<b>Details:</b>	See parameter P1001 (fixed frequency 1).						
<b>P1007</b>	<b>Fixed frequency 7</b>	<b>CStat:</b> CUT	<b>Datatype:</b> Float	<b>Unit:</b> Hz	<b>Min:</b> -650.00	<b>Def:</b> 30.00	<b>Level</b>
	<b>P-Group:</b> SETPOINT	<b>Active:</b> Immediately	<b>QuickComm.:</b> No	<b>Max:</b> 650.00	<b>2</b>		
	Defines fixed frequency setpoint 7.						
<b>Details:</b>	See parameter P1001 (fixed frequency 1).						
<b>P1016</b>	<b>Fixed frequency mode - Bit 0</b>	<b>CStat:</b> CT	<b>Datatype:</b> U16	<b>Unit:</b> -	<b>Min:</b> 1	<b>Def:</b> 1	<b>Level</b>
	<b>P-Group:</b> SETPOINT	<b>Active:</b> first confirm	<b>QuickComm.:</b> No	<b>Max:</b> 3	<b>3</b>		
	Fixed frequencies can be selected in three different modes. Parameter P1016 defines the mode of selection Bit 0.						
<b>Possible Settings:</b>	<ul style="list-style-type: none"> <li>1 Direct selection</li> <li>2 Direct selection + ON command</li> <li>3 Binary coded selection + ON command</li> </ul>						
<b>Details:</b>	See table in P1001 (fixed frequency 1) for description of how to use fixed frequencies.						
<b>P1017</b>	<b>Fixed frequency mode - Bit 1</b>	<b>CStat:</b> CT	<b>Datatype:</b> U16	<b>Unit:</b> -	<b>Min:</b> 1	<b>Def:</b> 1	<b>Level</b>
	<b>P-Group:</b> SETPOINT	<b>Active:</b> first confirm	<b>QuickComm.:</b> No	<b>Max:</b> 3	<b>3</b>		
	Fixed frequencies can be selected in three different modes. Parameter P1017 defines the mode of selection Bit 1.						
<b>Possible Settings:</b>	<ul style="list-style-type: none"> <li>1 Direct selection</li> <li>2 Direct selection + ON command</li> <li>3 Binary coded selection + ON command</li> </ul>						
<b>Details:</b>	See table in P1001 (fixed frequency 1) for description of how to use fixed frequencies.						

<b>P1018</b>	<b>Fixed frequency mode - Bit 2</b>				Min: 1	Level <b>3</b>
	CStat: CT	Datatype: U16	Unit: -	Def: 1		
	P-Group: SETPOINT	Active: first confirm	QuickComm.: No	Max: 3		

Fixed frequencies can be selected in three different modes. Parameter P1018 defines the mode of selection Bit 2.

**Possible Settings:**

- 1 Direct selection
- 2 Direct selection + ON command
- 3 Binary coded selection + ON command

**Details:**

See table in P1001 (fixed frequency 1) for description of how to use fixed frequencies.

<b>P1020</b>	<b>BI: Fixed freq. selection Bit 0</b>				Min: 0:0	Level <b>3</b>
	CStat: CT	Datatype: U32	Unit: -	Def: 0:0		
	P-Group: COMMANDS	Active: first confirm	QuickComm.: No	Max: 4000:0		

Defines origin of fixed frequency selection.

**Common Settings:**

- P1020 = 722.0 ==> Digital input 1  
P1021 = 722.1 ==> Digital input 2  
P1022 = 722.2 ==> Digital input 3

**Dependency:**

Accessible only if P0701 - P0703 = 99 (function of digital inputs = BICO)

<b>P1021</b>	<b>BI: Fixed freq. selection Bit 1</b>				Min: 0:0	Level <b>3</b>
	CStat: CT	Datatype: U32	Unit: -	Def: 0:0		
	P-Group: COMMANDS	Active: first confirm	QuickComm.: No	Max: 4000:0		

Defines origin of fixed frequency selection.

**Dependency:**

Accessible only if P0701 - P0703 = 99 (function of digital inputs = BICO)

**Details:**

See P1020 (fixed frequency selection Bit 0) for most common settings

<b>P1022</b>	<b>BI: Fixed freq. selection Bit 2</b>				Min: 0:0	Level <b>3</b>
	CStat: CT	Datatype: U32	Unit: -	Def: 0:0		
	P-Group: COMMANDS	Active: first confirm	QuickComm.: No	Max: 4000:0		

Defines origin of fixed frequency selection.

**Dependency:**

Accessible only if P0701 - P0703 = 99 (function of digital inputs = BICO)

**Details:**

See P1020 (fixed frequency selection Bit 0) for most common settings

<b>r1024</b>	<b>CO: Act. fixed frequency</b>			Min: -	Level <b>3</b>	
		Datatype: Float	Unit: Hz	Def: -		
	P-Group: SETPOINT			Max: -		

Displays sum total of selected fixed frequencies.

### 3.14 Motorized potentiometer (MOP)

<b>P1031</b>	<b>Setpoint memory of the MOP</b>				<b>Min:</b> 0	Level <b>2</b>
	<b>CStat:</b> CUT	<b>Datatype:</b> U16	<b>Unit:</b> -	<b>Def:</b> 0		
	<b>P-Group:</b> SETPOINT	<b>Active:</b> Immediately	<b>QuickComm.:</b> No	<b>Max:</b> 1		

Saves last motor potentiometer setpoint (MOP) that was active before OFF command or power down.

**Possible Settings:**

- 0 MOP setpoint will not be stored
- 1 MOP setpoint will be stored (P1040 is updated)

**Note:**

On next ON command, motor potentiometer setpoint will be the saved value in parameter P1040 (setpoint of the MOP).

<b>P1032</b>	<b>Inhibit negative MOP setpoints</b>				<b>Min:</b> 0	Level <b>2</b>
	<b>CStat:</b> CT	<b>Datatype:</b> U16	<b>Unit:</b> -	<b>Def:</b> 1		
	<b>P-Group:</b> SETPOINT	<b>Active:</b> first confirm	<b>QuickComm.:</b> No	<b>Max:</b> 1		

This parameter suppresses negative setpoints of the MOP output r1050.

**Possible Settings:**

- 0 Neg. MOP setpoint is allowed
- 1 Neg. MOP setpoint inhibited

**Note:**

The reversing functions (e.g. BOP-Reverse button if P0700 = 1) are not affected by the settings of P1032. Use P1110 to fully prevent change of direction in setpoint channel.

<b>P1035</b>	<b>BI: Enable MOP (UP-command)</b>				<b>Min:</b> 0:0	Level <b>3</b>
	<b>CStat:</b> CT	<b>Datatype:</b> U32	<b>Unit:</b> -	<b>Def:</b> 19:13		
	<b>P-Group:</b> COMMANDS	<b>Active:</b> first confirm	<b>QuickComm.:</b> No	<b>Max:</b> 4000:0		

Defines source for motor potentiometer setpoint increase frequency.

**Common Settings:**

- 722.0 = Digital input 1 (requires P0701 to be set to 99, BICO)
- 722.1 = Digital input 2 (requires P0702 to be set to 99, BICO)
- 722.2 = Digital input 3 (requires P0703 to be set to 99, BICO)
- 722.3 = Digital input 4 (via analog input, requires P0704 to be set to 99)
- 19.D = MOP up via BOP

<b>P1036</b>	<b>BI: Enable MOP (DOWN-command)</b>				<b>Min:</b> 0:0	Level <b>3</b>
	<b>CStat:</b> CT	<b>Datatype:</b> U32	<b>Unit:</b> -	<b>Def:</b> 19:14		
	<b>P-Group:</b> COMMANDS	<b>Active:</b> first confirm	<b>QuickComm.:</b> No	<b>Max:</b> 4000:0		

Defines source for motor potentiometer setpoint decrease frequency.

**Common Settings:**

- 722.0 = Digital input 1 (requires P0701 to be set to 99, BICO)
- 722.1 = Digital input 2 (requires P0702 to be set to 99, BICO)
- 722.2 = Digital input 3 (requires P0703 to be set to 99, BICO)
- 722.3 = Digital input 4 (via analog input, requires P0704 to be set to 99)
- 19.E = MOP down via BOP

<b>P1040</b>	<b>Setpoint of the MOP</b>				<b>Min:</b> -650.00	Level <b>2</b>
	<b>CStat:</b> CUT	<b>Datatype:</b> Float	<b>Unit:</b> Hz	<b>Def:</b> 5.00		
	<b>P-Group:</b> SETPOINT	<b>Active:</b> Immediately	<b>QuickComm.:</b> No	<b>Max:</b> 650.00		

Determines setpoint for motor potentiometer control (P1000 = 1).

**Note:**

- If motor potentiometer setpoint is selected either as main setpoint or additional setpoint, the reverse direction will be inhibited by default of P1032 (inhibit reverse direction of MOP).
  - To re-enable reverse direction, set P1032 = 0.
- For BOP/AOP control P1040 must be greater than the min. frequency P1080.

<b>r1050</b>	<b>CO: Act. Output freq. of the MOP</b>	<b>Min:</b> -	<b>Level</b>
	<b>Datatype:</b> Float <b>Unit:</b> Hz	<b>Def:</b> -	<b>3</b>
<b>P-Group:</b> SETPOINT		<b>Max:</b> -	

Displays output frequency of motor potentiometer setpoint ([Hz]).

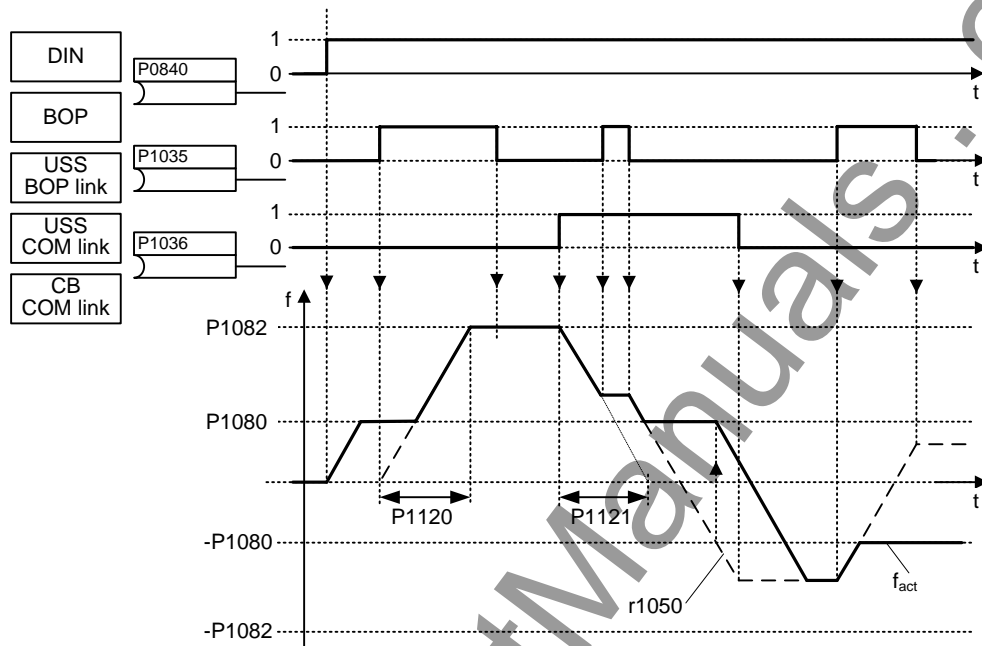

Possible parameter settings for the selection of MOP:

	Selection	MOP up	MOP down
<b>DIN</b>	P0719 = 0, P0700 = 2, P1000 = 1 or P0719 = 1, P0700 = 2	P0702 = 13 (DIN2)	P0703 = 14 (DIN3)
<b>BOP</b>	P0719 = 0, P0700 = 1, P1000 = 1 or P0719 = 1, P0700 = 1 or P0719 = 11	UP button	DOWN button
<b>USS on BOP link (AOP)</b>	P0719 = 0, P0700 = 4, P1000 = 1 or P0719 = 1, P0700 = 4 or P0719 = 41	USS control word r2032 Bit13	USS control word r2032 Bit14
<b>USS on COM link</b>	P0719 = 0, P0700 = 5, P1000 = 1 or P0719 = 1, P0700 = 5 or P0719 = 51	USS control word r2036 Bit13	USS control word r2036 Bit14
<b>CB</b>	P0719 = 0, P0700 = 6, P1000 = 1 or P0719 = 1, P0700 = 6 or P0719 = 61	CB control word r2090 Bit13	CB control word r2090 Bit14

### 3.15 JOG

<b>P1055</b>	<b>BI: Enable JOG right</b>	<b>Min:</b> 0:0	<b>Level</b> <b>3</b>	
	<b>CStat:</b> CT	<b>Datatype:</b> U32		<b>Def:</b> 0:0
	<b>P-Group:</b> COMMANDS	<b>Active:</b> first confirm		<b>Unit:</b> -

Defines source of JOG right.

**Common Settings:**

- 722.0 = Digital input 1 (requires P0701 to be set to 99, BICO)
- 722.1 = Digital input 2 (requires P0702 to be set to 99, BICO)
- 722.2 = Digital input 3 (requires P0703 to be set to 99, BICO)
- 722.3 = Digital input 4 (via analog input, requires P0704 to be set to 99)
- 19.8 = JOG right via BOP

**Dependency:**

Active only when P0719 < 10. See parameter P0719 (Selection of command/setpoint source).

<b>P1056</b>	<b>BI: Enable JOG left</b>	<b>Min:</b> 0:0	<b>Level</b> <b>3</b>	
	<b>CStat:</b> CT	<b>Datatype:</b> U32		<b>Def:</b> 0:0
	<b>P-Group:</b> COMMANDS	<b>Active:</b> first confirm		<b>Unit:</b> -

Defines source of JOG left.

**Common Settings:**

- 722.0 = Digital input 1 (requires P0701 to be set to 99, BICO)
- 722.1 = Digital input 2 (requires P0702 to be set to 99, BICO)
- 722.2 = Digital input 3 (requires P0703 to be set to 99, BICO)
- 722.3 = Digital input 4 (via analog input, requires P0704 to be set to 99)
- 19.9 = JOG left via BOP

**Dependency:**

Active only when P0719 < 10. See parameter P0719 (Selection of command/setpoint source).

<b>P1058</b>	<b>JOG frequency right</b>	<b>Min:</b> 0.00	<b>Level</b> <b>2</b>	
	<b>CStat:</b> CUT	<b>Datatype:</b> Float		<b>Def:</b> 5.00
	<b>P-Group:</b> SETPOINT	<b>Active:</b> Immediately		<b>Unit:</b> Hz

Jogging increases the motor frequency by small amounts. The JOG buttons uses a non-latching switch on one of the digital inputs to control the motor frequency.

If JOG clockwise (jogging clockwise) or JOG counter-clockwise is selected, the speed is increased until the value, set in P1058 is reached.

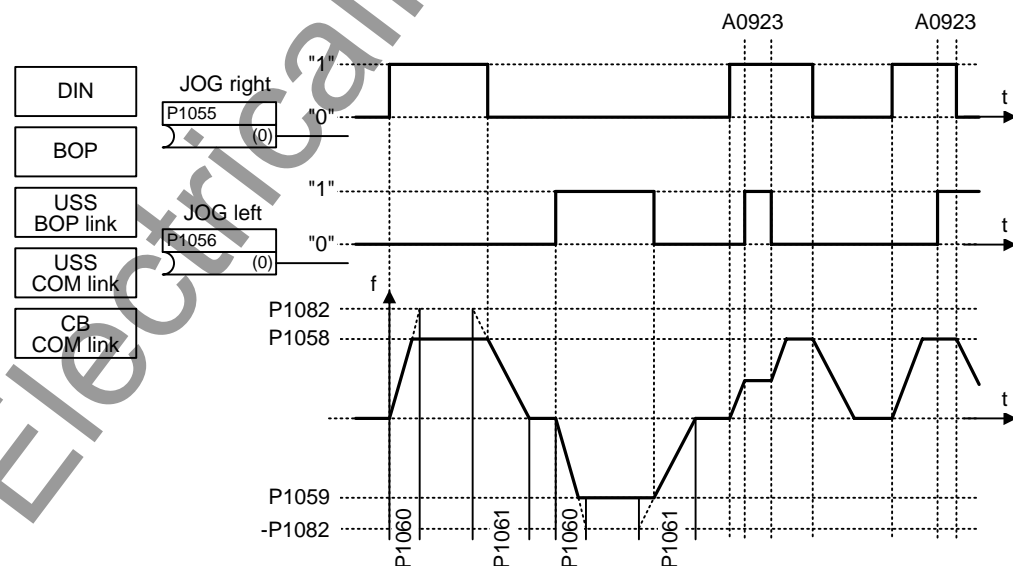

**Dependency:**

P1060 and P1061 set up and down ramp times respectively for jogging.

<b>P1059</b>	<b>JOG frequency left</b>	<b>Min:</b> 0.00	<b>Level</b> <b>2</b>	
	<b>CStat:</b> CUT	<b>Datatype:</b> Float		<b>Def:</b> 5.00
	<b>P-Group:</b> SETPOINT	<b>Active:</b> Immediately		<b>Unit:</b> Hz

While JOG left is selected, this parameter determines the frequency at which the inverter will run.

**Dependency:**

P1060 and P1061 set up and down ramp times respectively for jogging.

<b>P1060</b>	<b>JOG ramp-up time</b>			<b>Min:</b> 0.00	<b>Level</b> <b>2</b>
	<b>CStat:</b> CUT	<b>Datatype:</b> Float	<b>Unit:</b> s	<b>Def:</b> 10.00	
	<b>P-Group:</b> SETPOINT	<b>Active:</b> first confirm	<b>QuickComm.:</b> No	<b>Max:</b> 650.00	

Sets jog ramp-up time. This is the time used while jogging is active.

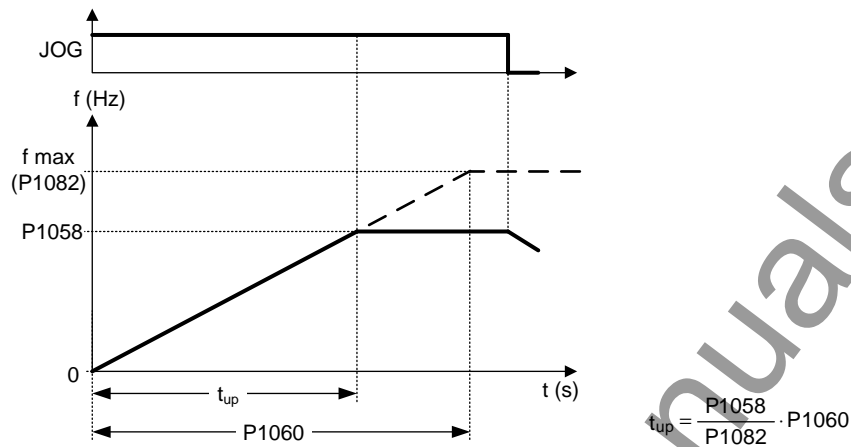

**Notice:**

Ramp times will be used as follows:

- P1060 / P1061 : JOG mode is active
- P1120 / P1121 : Normal mode (ON/OFF) is active
- P1060 / P1061 : Normal mode (ON/OFF) and P1124 is active

<b>P1061</b>	<b>JOG ramp-down time</b>			<b>Min:</b> 0.00	<b>Level</b> <b>2</b>
	<b>CStat:</b> CUT	<b>Datatype:</b> Float	<b>Unit:</b> s	<b>Def:</b> 10.00	
	<b>P-Group:</b> SETPOINT	<b>Active:</b> first confirm	<b>QuickComm.:</b> No	<b>Max:</b> 650.00	

Sets ramp-down time. This is the time used while jogging is active.

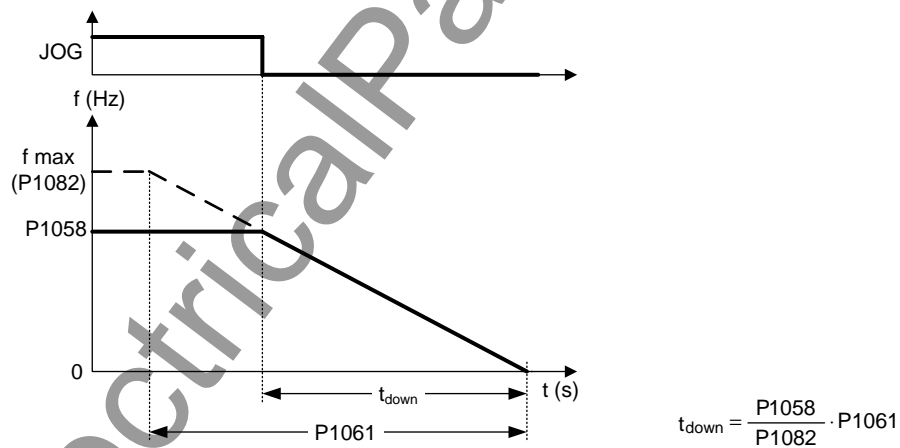

**Notice:**

Ramp times will be used as follows:

- P1060 / P1061 : JOG mode is active
- P1120 / P1121 : Normal mode (ON/OFF) is active
- P1060 / P1061 : Normal mode (ON/OFF) and P1124 is active

### 3.16 Setpoint channel

<b>P1070</b>	<b>CI: Main setpoint</b>			<b>Min:</b> 0:0	Level <b>3</b>
	<b>CStat:</b> CT	<b>Datatype:</b> U32	<b>Unit:</b> -	<b>Def:</b> 755:0	
	<b>P-Group:</b> SETPOINT	<b>Active:</b> first confirm	<b>QuickComm.:</b> No	<b>Max:</b> 4000:0	

Defines source of main setpoint.

**Common Settings:**

755 = Analog input 1 setpoint  
1024 = Fixed frequency setpoint  
1050 = Motor potentiometer (MOP) setpoint

<b>P1071</b>	<b>CI: Main setpoint scaling</b>			<b>Min:</b> 0:0	Level <b>3</b>
	<b>CStat:</b> CT	<b>Datatype:</b> U32	<b>Unit:</b> -	<b>Def:</b> 1:0	
	<b>P-Group:</b> SETPOINT	<b>Active:</b> first confirm	<b>QuickComm.:</b> No	<b>Max:</b> 4000:0	

Defines source of the main setpoint scaling.

**Common Settings:**

755 = Analog input 1 setpoint  
1024 = Fixed frequency setpoint  
1050 = Motor potentiometer (MOP) setpoint

<b>P1074</b>	<b>BI: Disable additional setpoint</b>			<b>Min:</b> 0:0	Level <b>3</b>
	<b>CStat:</b> CUT	<b>Datatype:</b> U32	<b>Unit:</b> -	<b>Def:</b> 0:0	
	<b>P-Group:</b> COMMANDS	<b>Active:</b> first confirm	<b>QuickComm.:</b> No	<b>Max:</b> 4000:0	

Disables additional setpoint

**Common Settings:**

722.0 = Digital input 1 (requires P0701 to be set to 99, BICO)  
722.1 = Digital input 2 (requires P0702 to be set to 99, BICO)  
722.2 = Digital input 3 (requires P0703 to be set to 99, BICO)  
722.3 = Digital input 4 (via analog input, requires P0704 to be set to 99)

<b>P1075</b>	<b>CI: Additional setpoint</b>			<b>Min:</b> 0:0	Level <b>3</b>
	<b>CStat:</b> CT	<b>Datatype:</b> U32	<b>Unit:</b> -	<b>Def:</b> 0:0	
	<b>P-Group:</b> SETPOINT	<b>Active:</b> first confirm	<b>QuickComm.:</b> No	<b>Max:</b> 4000:0	

Defines source of the additional setpoint (to be added to main setpoint).

**Common Settings:**

755 = Analog input 1 setpoint  
1024 = Fixed frequency setpoint  
1050 = Motor potentiometer (MOP) setpoint

<b>P1076</b>	<b>CI: Additional setpoint scaling</b>			<b>Min:</b> 0:0	Level <b>3</b>
	<b>CStat:</b> CT	<b>Datatype:</b> U32	<b>Unit:</b> -	<b>Def:</b> 1:0	
	<b>P-Group:</b> SETPOINT	<b>Active:</b> first confirm	<b>QuickComm.:</b> No	<b>Max:</b> 4000:0	

Defines source of scaling for additional setpoint (to be added to main setpoint).

**Common Settings:**

1 = Scaling of 1.0 (100%)  
755 = Analog input 1 Setpoint  
1024 = Fixed Frequency Setpoint  
1050 = MOP Setpoint

<b>r1078</b>	<b>CO: Total frequency setpoint</b>			<b>Min:</b> -	Level <b>3</b>
		<b>Datatype:</b> Float	<b>Unit:</b> Hz	<b>Def:</b> -	
	<b>P-Group:</b> SETPOINT			<b>Max:</b> -	

Displays sum of main and additional setpoints in [Hz].

<b>r1079</b>	<b>CO: Selected frequency setpoint</b>			<b>Min:</b> -	Level <b>3</b>
		<b>Datatype:</b> Float	<b>Unit:</b> Hz	<b>Def:</b> -	
	<b>P-Group:</b> SETPOINT			<b>Max:</b> -	

Displays selected frequency setpoint.

Following frequency setpoints are displayed:

- r1078 Total frequency setpoint
- P1058 JOG frequency right
- P1059 JOG frequency left

**Dependency:**

P1055 (BI: Enable JOG right) or P1056 (BI: Enable JOG left) define command source of JOG right or JOG left respectively.

**Note:**

P1055 = 0 and P1056 = 0 ==> Total frequency setpoint is selected.

<b>P1080</b>	<b>Min. frequency</b>			<b>Min:</b> 0.00	<b>Level</b> <b>1</b>
	<b>CStat:</b> CUT	<b>Datatype:</b> Float	<b>Unit:</b> Hz	<b>Def:</b> 0.00	
	<b>P-Group:</b> SETPOINT	<b>Active:</b> Immediately	<b>QuickComm.:</b> Yes	<b>Max:</b> 650.00	

Sets minimum motor frequency [Hz] at which motor will run irrespective of frequency setpoint.

The minimum frequency P1080 represents a masking frequency of 0 Hz for all frequency target value sources (e.g. ADC, MOP, FF, USS), with the exception of the JOG target value source (analogous to P1091). Thus the frequency band +/- P1080 is run through in optimum time by means of the acceleration/deceleration ramps. Dwelling in the frequency band is not possible (see example).

Furthermore, an undershoot of the actual frequency  $f_{act}$  below min. frequency P1080 is output by the following signal function.

**Example:**

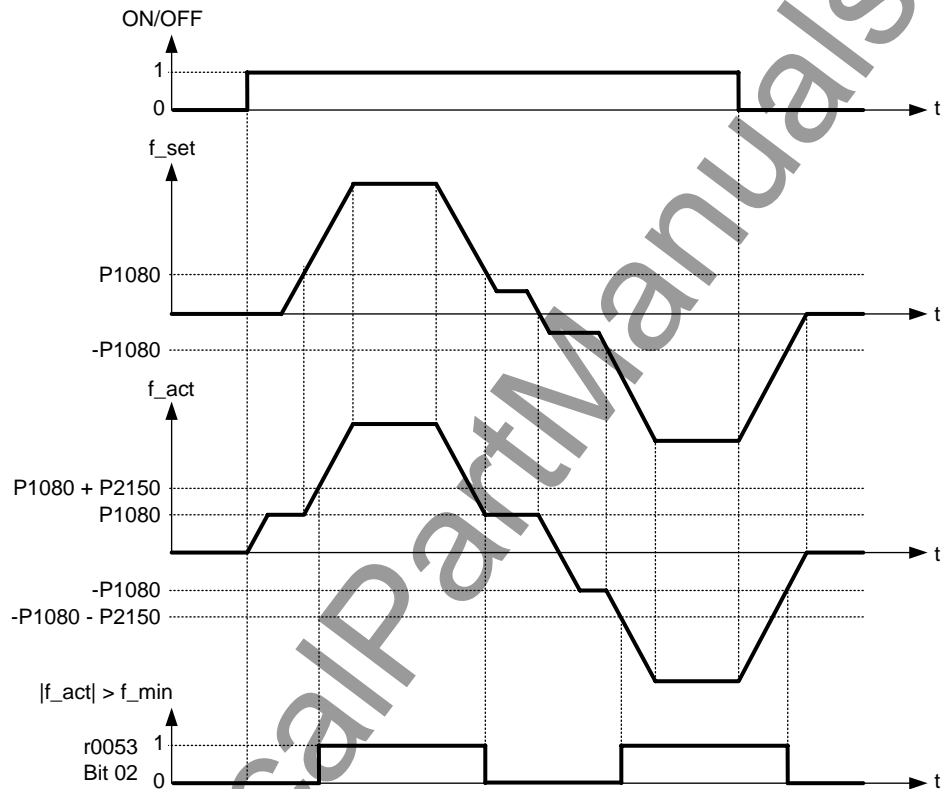

**Note:**

Value set here is valid both for clockwise and for anticlockwise rotation.

Under certain conditions (e.g. ramping, current limiting), motor can run below minimum frequency.

<b>P1082</b>	<b>Max. frequency</b>			<b>Min:</b> 0.00	<b>Level</b> <b>1</b>
	<b>CStat:</b> CT	<b>Datatype:</b> Float	<b>Unit:</b> Hz	<b>Def:</b> 50.00	
	<b>P-Group:</b> SETPOINT	<b>Active:</b> first confirm	<b>QuickComm.:</b> Yes	<b>Max:</b> 650.00	

Sets maximum motor frequency [Hz] at which motor will run irrespective of the frequency setpoint. The value set here is valid for both clockwise and anticlockwise rotation.

Furthermore, the monitoring function  $|f_{act}| \geq P1082$  (r0052 Bit10, see example below) is affected by this parameter.

**Example:**

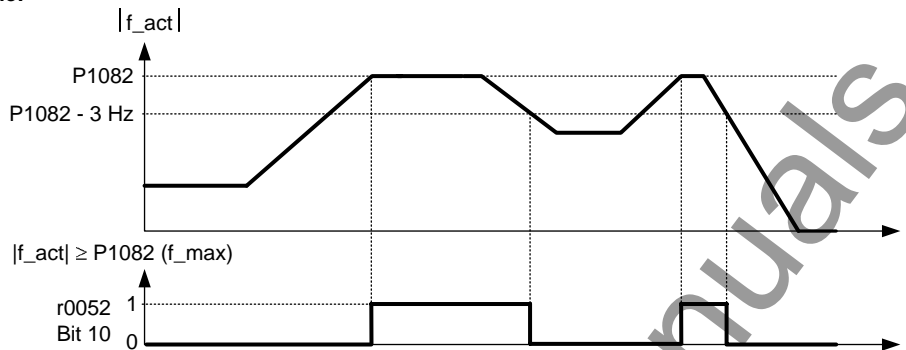

**Dependency:**

The maximal value of motor frequency P1082 is limited to pulse frequency P1800. P1082 is dependent on the derating characteristic as followed:

		P1800			
		2 kHz	4 kHz	6 kHz	8 - 16 kHz
$f_{max}$	P1082	0 - 133.3 Hz	0 - 266.6 Hz	0 - 400 Hz	0 - 650 Hz

The maximum output frequency of inverter can be exceeded if one of the following is active:

- p1335  $\neq$  0 (Slip compensation active) :

$$f_{max}(p1335) = f_{max} + f_{slip,max} = p1082 + \frac{p1336}{100} \cdot \frac{r0330}{100} \cdot p0310$$

- p1200  $\neq$  0 (Flying restart active) :

$$f_{max}(p1200) = f_{max} + 2 \cdot f_{slip,nom} = p1082 + 2 \cdot \frac{r0330}{100} \cdot p0310$$

**Note:**

When using the setpoint source

- Analog Input
- USS
- CB (e.g. PROFIBUS)

The setpoint frequency (in Hz) is cyclically calculated using a percentage value (e.g. for the analog input r0754) or a hexadecimal value (e.g. for the USS r2018[1]) and the reference frequency P2000.

If for example P1082 = 80 Hz, P2000 = 50 Hz and the analog input is parameterised with P0757 = 0 V, P0758 = 0 %, P0759 = 10 V, P0760 = 100 %, a setpoint frequency of 50 Hz will be applied at 10 V of the analog input.

<b>P1091</b>	<b>Skip frequency 1</b>	<b>Min:</b> 0.00	<b>Level</b>
	<b>CStat:</b> CUT	<b>Datatype:</b> Float	<b>Unit:</b> Hz
	<b>P-Group:</b> SETPOINT	<b>Active:</b> Immediately	<b>QuickComm.:</b> No
		<b>Def:</b> 0.00	<b>3</b>
		<b>Max:</b> 650.00	

Defines skip frequency 1 which avoids effects of mechanical resonance and suppresses frequencies within +/- P1101 (skip frequency bandwidth).

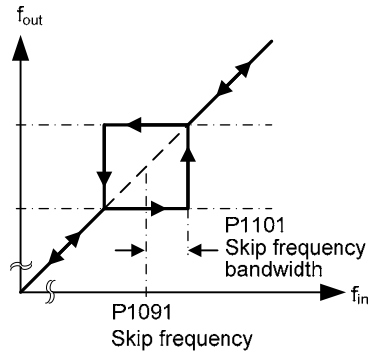

**Notice:**

- Stationary operation is not possible within the suppressed frequency range; the range is merely passed through (on the ramp).
- For example, if P1091 = 10 Hz and P1101 = 2 Hz, it is not possible to operate continuously between 10 Hz +/- 2 Hz (i.e. between 8 and 12 Hz).

<b>P1092</b>	<b>Skip frequency 2</b>	<b>Min:</b> 0.00	<b>Level</b>
	<b>CStat:</b> CUT	<b>Datatype:</b> Float	<b>Unit:</b> Hz
	<b>P-Group:</b> SETPOINT	<b>Active:</b> Immediately	<b>QuickComm.:</b> No
		<b>Def:</b> 0.00	<b>3</b>
		<b>Max:</b> 650.00	

Defines skip frequency 2 which avoids effects of mechanical resonance and suppresses frequencies within +/- P1101 (skip frequency bandwidth).

**Details:**

See P1091 (skip frequency 1).

<b>P1093</b>	<b>Skip frequency 3</b>	<b>Min:</b> 0.00	<b>Level</b>
	<b>CStat:</b> CUT	<b>Datatype:</b> Float	<b>Unit:</b> Hz
	<b>P-Group:</b> SETPOINT	<b>Active:</b> Immediately	<b>QuickComm.:</b> No
		<b>Def:</b> 0.00	<b>3</b>
		<b>Max:</b> 650.00	

Defines skip frequency 3 which avoids effects of mechanical resonance and suppresses frequencies within +/- P1101 (skip frequency bandwidth).

**Details:**

See P1091 (skip frequency 1).

<b>P1094</b>	<b>Skip frequency 4</b>	<b>Min:</b> 0.00	<b>Level</b>
	<b>CStat:</b> CUT	<b>Datatype:</b> Float	<b>Unit:</b> Hz
	<b>P-Group:</b> SETPOINT	<b>Active:</b> Immediately	<b>QuickComm.:</b> No
		<b>Def:</b> 0.00	<b>3</b>
		<b>Max:</b> 650.00	

Defines skip frequency 4 which avoids effects of mechanical resonance and suppresses frequencies within +/- P1101 (skip frequency bandwidth).

**Details:**

See P1091 (skip frequency 1).

<b>P1101</b>	<b>Skip frequency bandwidth</b>	<b>Min:</b> 0.00	<b>Level</b>
	<b>CStat:</b> CUT	<b>Datatype:</b> Float	<b>Unit:</b> Hz
	<b>P-Group:</b> SETPOINT	<b>Active:</b> Immediately	<b>QuickComm.:</b> No
		<b>Def:</b> 2.00	<b>3</b>
		<b>Max:</b> 10.00	

Delivers frequency bandwidth to be applied to skip frequencies (in [Hz]).

**Details:**

See P1091 (skip frequency 1).

<b>P1110</b>	<b>BI: Inhibit neg. freq. setpoint</b>	<b>Min:</b> 0:0	<b>Level</b>
	<b>CStat:</b> CT	<b>Datatype:</b> U32	<b>Unit:</b> -
	<b>P-Group:</b> COMMANDS	<b>Active:</b> first confirm	<b>QuickComm.:</b> No
		<b>Def:</b> 0:0	<b>3</b>
		<b>Max:</b> 4000:0	

This parameter suppresses negative setpoints. Therefore, modification of the motor direction is inhibited to the setpoint channel.

**Common Settings:**

- 0 = Disabled
- 1 = Enabled

**Notice:**

- Where
- If a min. frequency (P1080) and a negative setpoint are given, the motor is accelerated by a positive value in relationship to the min. frequency.
  - This function does not disable the "reverse command functions" (e.g. Reverse, ON left); rather, a reverse command causes motor to run in the positive direction only, as described above.

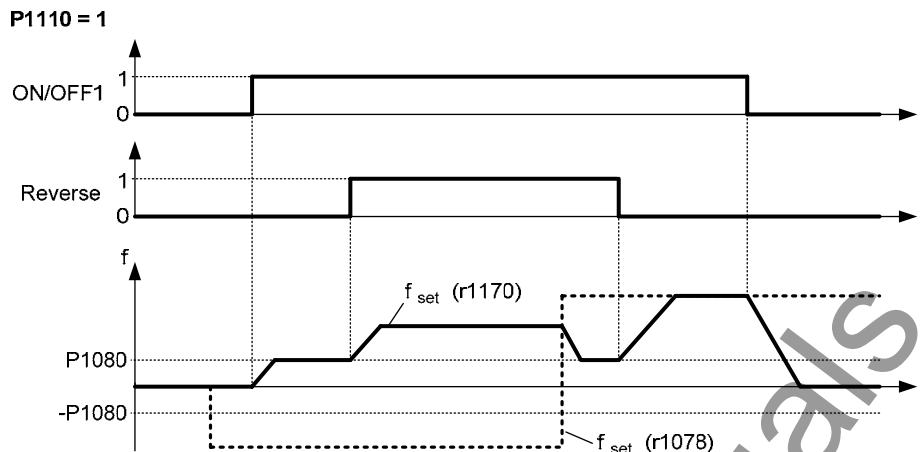

<b>P1113</b>	<b>BI: Reverse</b>	<b>Datatype:</b> U32	<b>Unit:</b> -	<b>Min:</b> 0:0	Level <b>3</b>
	<b>CStat:</b> CT	<b>Active:</b> first confirm	<b>QuickComm.:</b> No	<b>Def:</b> 722:1	
	<b>P-Group:</b> COMMANDS			<b>Max:</b> 4000:0	

Defines source of reverse command.

**Common Settings:**

- 722.0 = Digital input 1 (requires P0701 to be set to 99, BICO)
- 722.1 = Digital input 2 (requires P0702 to be set to 99, BICO)
- 722.2 = Digital input 3 (requires P0703 to be set to 99, BICO)
- 19.B = Reverse via BOP

**Dependency:**

Active only when P0719 < 10. See parameter P0719 (Selection of command/setpoint source).

**Note:**

P1113: =: 0 → Reverse disabled via AOP/BOP Reverse key.

<b>r1114</b>	<b>CO: Freq. setp. after dir. ctrl.</b>	<b>Datatype:</b> Float	<b>Unit:</b> Hz	<b>Min:</b> -	Level <b>3</b>
	<b>P-Group:</b> SETPOINT			<b>Def:</b> -	
				<b>Max:</b> -	

Displays setpoint frequency after change of direction.

### 3.17 Ramp-function generator

<b>r1119</b>	<b>CO: Freq. setpoint before RFG</b>	<b>Datatype:</b> Float	<b>Unit:</b> Hz	<b>Min:</b> -	<b>Level</b> <b>3</b>
	<b>P-Group:</b> SETPOINT			<b>Def:</b> - <b>Max:</b> -	

Displays output frequency after modification by other functions, e.g.:

- P1110 BI: Inhibit neg. freq. setpoint,
- P1091 - P1094 skip frequencies,
- P1080 Min. frequency,
- P1082 Max. frequency,
- limitations,
- etc.

<b>P1120</b>	<b>Ramp-up time</b>	<b>Datatype:</b> Float	<b>Unit:</b> s	<b>Min:</b> 0.00	<b>Level</b> <b>1</b>
	<b>CStat:</b> CUT	<b>Active:</b> first confirm	<b>QuickComm.:</b> Yes	<b>Def:</b> 10.00	
	<b>P-Group:</b> SETPOINT			<b>Max:</b> 650.00	

Time taken for motor to accelerate from standstill up to maximum motor frequency (P1082) when no rounding is used.

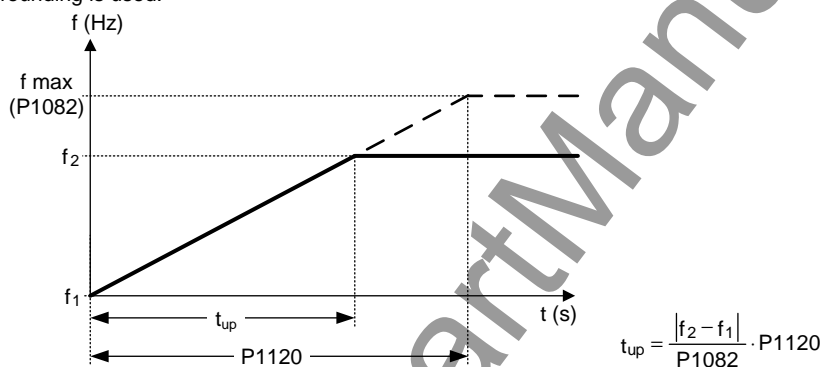

Setting the ramp-up time too short can cause the inverter to trip (overcurrent).

**Note:**

If an external frequency setpoint with set ramp rates is used (e.g. from a PLC). The best way to achieve optimum drive performance is to set ramp times in P1120 and P1121 slightly shorter than those of the PLC.

**Notice:**

Ramp times will be used as follows:

- P1060 / P1061 : JOG mode is active
- P1120 / P1121 : Normal mode (ON/OFF) is active
- P1060 / P1061 : Normal mode (ON/OFF) and P1124 is active

<b>P1121</b>	<b>Ramp-down time</b>	<b>Datatype:</b> Float	<b>Unit:</b> s	<b>Min:</b> 0.00	<b>Level</b> <b>1</b>
	<b>CStat:</b> CUT	<b>Active:</b> first confirm	<b>QuickComm.:</b> Yes	<b>Def:</b> 10.00	
	<b>P-Group:</b> SETPOINT			<b>Max:</b> 650.00	

Time taken for motor to decelerate from maximum motor frequency (P1082) down to standstill when no rounding is used.

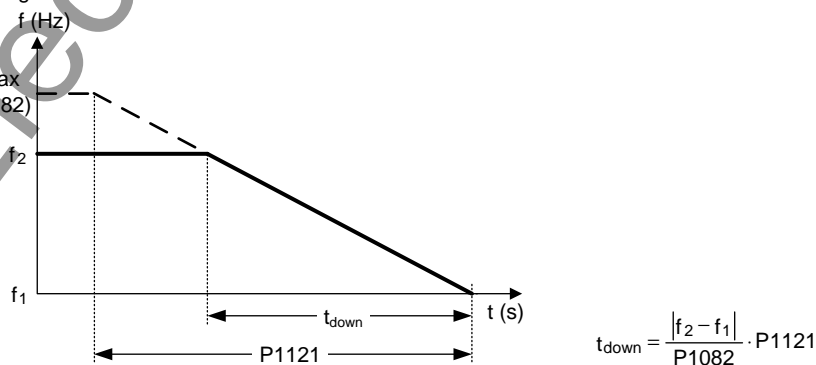

**Notice:**

Setting the ramp-down time too short can cause the inverter to trip (overcurrent (F0001) / overvoltage (F0002)).

Ramp times will be used as follows:

- P1060 / P1061 : JOG mode is active
- P1120 / P1121 : Normal mode (ON/OFF) is active
- P1060 / P1061 : Normal mode (ON/OFF) and P1124 is active

<b>P1124</b>	<b>BI: Enable JOG ramp times</b>	<b>Min:</b> 0:0	<b>Level</b> <b>3</b>	
	<b>CStat:</b> CT	<b>Datatype:</b> U32		<b>Def:</b> 0:0
	<b>P-Group:</b> COMMANDS	<b>Active:</b> first confirm		<b>QuickComm.:</b> No

Defines source for switching between jog ramp times (P1060, P1061) and normal ramp times (P1120, P1121) as applied to the RFG. This parameter is valid for normal mode (ON/OFF) only.

**Common Settings:**

722.0 = Digital input 1 (requires P0701 to be set to 99, BICO)  
 722.1 = Digital input 2 (requires P0702 to be set to 99, BICO)  
 722.2 = Digital input 3 (requires P0703 to be set to 99, BICO)

**Notice:**

P1124 does not have any impact when JOG mode is selected. In this case, jog ramp times (P1060, P1061) will be used all the time.

Ramp times will be used as follows:

- P1060 / P1061 : JOG mode is active
- P1120 / P1121 : Normal mode (ON/OFF) is active
- P1060 / P1061 : Normal mode (ON/OFF) and P1124 is active

<b>P1130</b>	<b>Ramp-up initial rounding time</b>	<b>Min:</b> 0.00	<b>Level</b> <b>2</b>	
	<b>CStat:</b> CUT	<b>Datatype:</b> Float		<b>Def:</b> 0.00
	<b>P-Group:</b> SETPOINT	<b>Active:</b> first confirm		<b>QuickComm.:</b> No

Defines initial rounding time in seconds as shown on the diagram below.

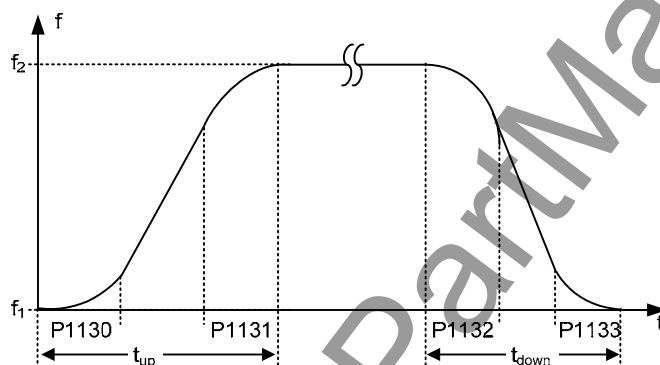

where:

$$\text{for } \frac{f_2 - f_1}{P1082} \cdot P1120 \geq \frac{1}{2} (P1130 + P1131)$$

$$t_{up} = \frac{1}{2} (P1130 + P1131) + \frac{f_2 - f_1}{P1082} \cdot P1120$$

$$\text{for } \frac{f_2 - f_1}{P1082} \cdot P1121 \geq \frac{1}{2} (P1132 + P1133)$$

$$t_{down} = \frac{1}{2} (P1132 + P1133) + \frac{f_2 - f_1}{P1082} \cdot P1121$$

**Note:**

- If short or zero ramp times (P1120, P1121 < P1130, P1131, P1132, P1133) are set, the total ramp up time (t<sub>up</sub>) or ramp down time (t<sub>down</sub>) will not depend on P1130.
- See equations above for valid conditions to calculate t<sub>up</sub> and t<sub>down</sub>.
- Rounding times are recommended, since they prevent an abrupt response, thus avoiding detrimental effects on the mechanics.
- Rounding times are not recommended when analog inputs are used, since they would result in overshoot/undershoot in the inverter response.

<b>P1131</b>	<b>Ramp-up final rounding time</b>	<b>Min:</b> 0.00	<b>Level</b> <b>2</b>	
	<b>CStat:</b> CUT	<b>Datatype:</b> Float		<b>Def:</b> 0.00
	<b>P-Group:</b> SETPOINT	<b>Active:</b> first confirm		<b>QuickComm.:</b> No

Defines rounding time at end of ramp-up as shown in P1130 (ramp-up initial rounding time).

**Details:**

See parameter P1130.

<b>P1132</b>	<b>Ramp-down initial rounding time</b>	<b>Min:</b> 0.00	<b>Level</b> <b>2</b>	
	<b>CStat:</b> CUT	<b>Datatype:</b> Float		<b>Def:</b> 0.00
	<b>P-Group:</b> SETPOINT	<b>Active:</b> first confirm		<b>QuickComm.:</b> No

Defines rounding time at start of ramp-down as shown in P1130 (ramp-up initial rounding time).

**Details:**

See parameter P1130.

<b>P1133</b>	<b>Ramp-down final rounding time</b>	<b>Min:</b> 0.00	<b>Level</b>
	<b>CStat:</b> CUT	<b>Datatype:</b> Float	<b>Unit:</b> s
	<b>P-Group:</b> SETPOINT	<b>Active:</b> first confirm	<b>QuickComm.:</b> No
		<b>Def:</b> 0.00	<b>2</b>
		<b>Max:</b> 40.00	

Defines rounding time at end of ramp-down as shown in P1130 (ramp-up initial rounding time).

**Details:**

See parameter P1130.

<b>P1134</b>	<b>Rounding type</b>	<b>Min:</b> 0	<b>Level</b>
	<b>CStat:</b> CUT	<b>Datatype:</b> U16	<b>Unit:</b> -
	<b>P-Group:</b> SETPOINT	<b>Active:</b> Immediately	<b>QuickComm.:</b> No
		<b>Def:</b> 0	<b>2</b>
		<b>Max:</b> 1	

Defines the smoothing which is active by setpoint modifications during acceleration or deceleration (e.g. new setpoint, OFF1, OFF3, REV).

This smoothing is applied, if the motor is ramped-up or ramped-down and

- P1134 = 0,
- P1132 > 0, P1133 > 0 and
- the setpoint is not yet reached.

**P1132 > 0, P1133 > 0**

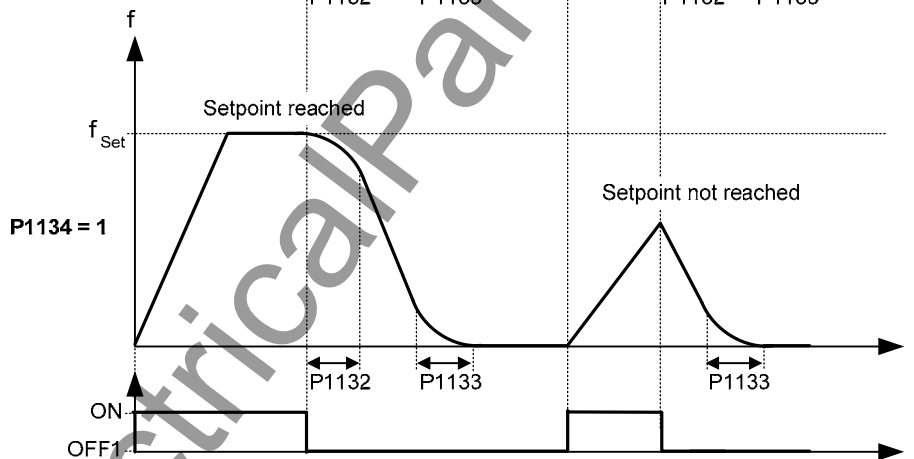
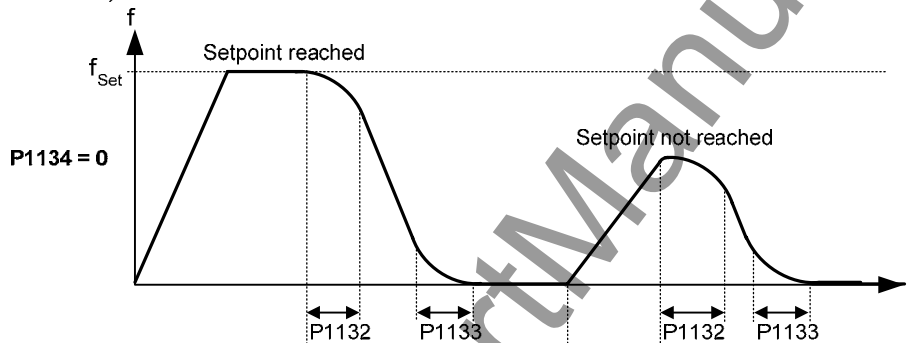

**Possible Settings:**

- 0 Continuous smoothing
- 1 Discontinuous smoothing

**Dependency:**

No effect until P1132 (Ramp-down initial rounding time) or P1133 (Ramp-down final rounding time) > 0 s.

<b>P1135</b>	<b>OFF3 ramp-down time</b>	<b>Min:</b> 0.00	<b>Level</b>
	<b>CStat:</b> CUT	<b>Datatype:</b> Float	<b>Unit:</b> s
	<b>P-Group:</b> SETPOINT	<b>Active:</b> first confirm	<b>QuickComm.:</b> Yes
		<b>Def:</b> 5.00	<b>2</b>
		<b>Max:</b> 650.00	

Defines ramp-down time from maximum frequency to standstill for OFF3 command.

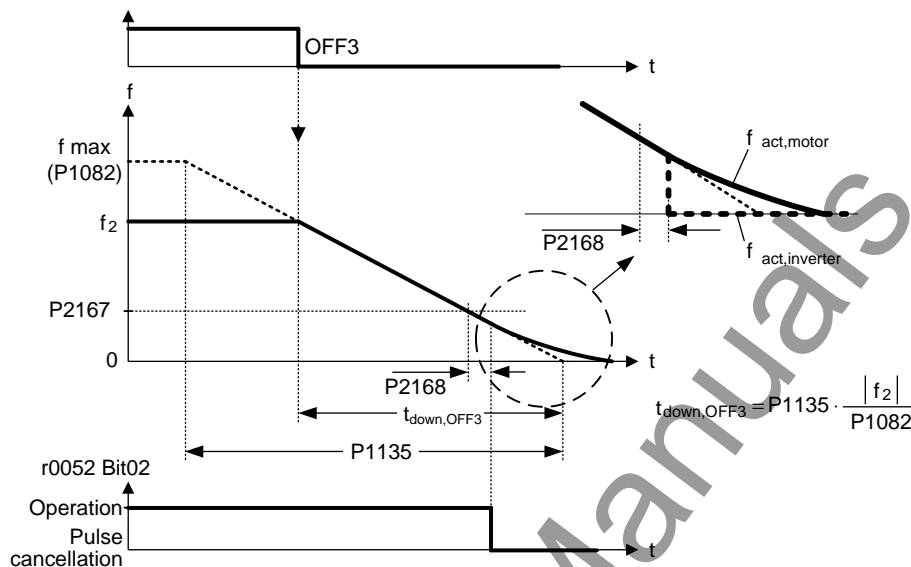

**Note:**

This time may be exceeded if the VDC\_max. level is reached.

<b>P1140</b>	<b>BI: RFG enable</b>	<b>Min:</b> 0:0	<b>Level</b>
	<b>CStat:</b> CT	<b>Datatype:</b> U32	<b>Unit:</b> -
	<b>P-Group:</b> COMMANDS	<b>Active:</b> first confirm	<b>QuickComm.:</b> No
		<b>Def:</b> 1:0	<b>3</b>
		<b>Max:</b> 4000:0	

Defines command source of RFG enable command (RFG: ramp function generator). If binary input is equal to zero then the RFG output will be set immediately to 0.

<b>P1141</b>	<b>BI: RFG start</b>	<b>Min:</b> 0:0	<b>Level</b>
	<b>CStat:</b> CT	<b>Datatype:</b> U32	<b>Unit:</b> -
	<b>P-Group:</b> COMMANDS	<b>Active:</b> first confirm	<b>QuickComm.:</b> No
		<b>Def:</b> 1:0	<b>3</b>
		<b>Max:</b> 4000:0	

Defines command source of RFG start command (RFG: ramp function generator). If binary input is equal to zero then the RFG output is held at it present value.

<b>P1142</b>	<b>BI: RFG enable setpoint</b>	<b>Min:</b> 0:0	<b>Level</b>
	<b>CStat:</b> CT	<b>Datatype:</b> U32	<b>Unit:</b> -
	<b>P-Group:</b> COMMANDS	<b>Active:</b> first confirm	<b>QuickComm.:</b> No
		<b>Def:</b> 1:0	<b>3</b>
		<b>Max:</b> 4000:0	

Defines command source of RFG enable setpoint command (RFG: ramp function generator). If binary input is equal to zero then the RFG input will be set to zero and the RFG output will be ramp-down to zero.

<b>r1170</b>	<b>CO: Frequency setpoint after RFG</b>	<b>Min:</b> -	<b>Level</b>
		<b>Datatype:</b> Float	<b>Unit:</b> Hz
	<b>P-Group:</b> SETPOINT	<b>Active:</b> -	<b>QuickComm.:</b> -
		<b>Def:</b> -	<b>3</b>
		<b>Max:</b> -	

Displays overall frequency setpoint after ramp generator.

### 3.18 Flying restart

<b>P1200</b>	<b>Flying start</b>	<b>Datatype:</b> U16	<b>Unit:</b> -	<b>Min:</b> 0	<b>Level</b> <b>2</b>
	<b>CStat:</b> CUT	<b>Active:</b> first confirm	<b>QuickComm.:</b> No	<b>Def:</b> 0	
	<b>P-Group:</b> FUNC			<b>Max:</b> 6	

Starts inverter onto a spinning motor by rapidly changing the output frequency of the inverter until the actual motor speed has been found. Then, the motor runs up to setpoint using the normal ramp time.

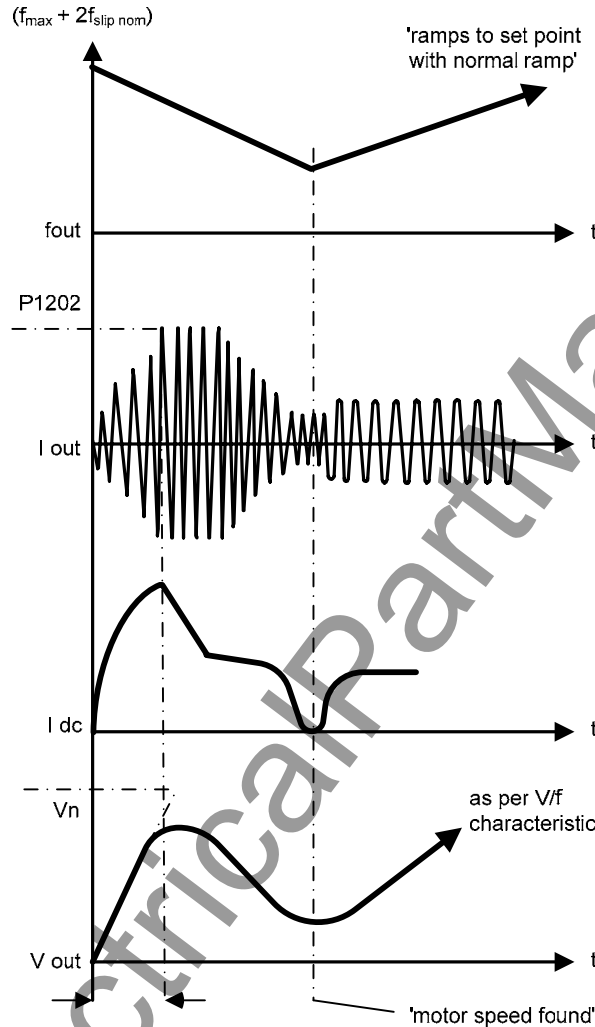

**Possible Settings:**

- 0 Flying start disabled
- 1 Flying start is always active, start in direction of setpoint
- 2 Flying start is active if power on, fault, OFF2, start in direction of setpoint
- 3 Flying start is active if fault, OFF2, start in direction of setpoint
- 4 Flying start is always active, only in direction of setpoint
- 5 Flying start is active if power on, fault, OFF2, only in direction of setpoint
- 6 Flying start is active if fault, OFF2, only in direction of setpoint

**Note:**

- Useful for motors with high inertia loads.
- Settings 1 to 3 search in both directions.
- Settings 4 to 6 search only in direction of setpoint.
- Flying start must be used in cases where the motor may still be turning (e.g. after a short mains break) or can be driven by the load. Otherwise, overcurrent trips will occur.

<b>P1202</b>	<b>Motor-current: Flying start</b>	<b>Datatype:</b> U16	<b>Unit:</b> %	<b>Min:</b> 10	<b>Level</b> <b>3</b>
	<b>CStat:</b> CUT	<b>Active:</b> first confirm	<b>QuickComm.:</b> No	<b>Def:</b> 100	
	<b>P-Group:</b> FUNC			<b>Max:</b> 200	

Defines search current used for flying start. Value is in [%] based on rated motor current (P0305).

**Note:**

- If the search current is reduced, the flying restart behavior can be improved if the system inertia is not very high.

<b>P1203</b>	<b>Search rate: Flying start</b>	<b>Min:</b> 10	<b>Level</b> <b>3</b>	
	<b>CStat:</b> CUT	<b>Datatype:</b> U16		<b>Unit:</b> %
	<b>P-Group:</b> FUNC	<b>Active:</b> first confirm		<b>QuickComm.:</b> No
		<b>Def:</b> 100		
		<b>Max:</b> 200		

Sets factor by which the output frequency changes during flying start to synchronize with turning motor. This value is entered in [%] defines the reciprocal initial gradient in the search sequence (see curve below). Parameter P1203 influences the time taken to search for the motor frequency.

The search time is the time taken to search through all frequencies between max. frequency  $P1082 + 2 \times f\_slip$  to 0 Hz.

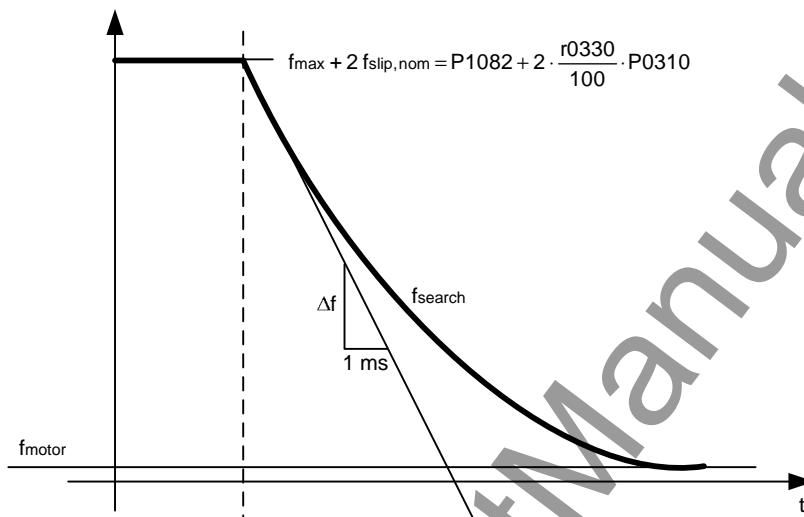

$$P1203[\%] = \frac{\Delta t [\text{ms}]}{\Delta f [\text{Hz}]} \cdot \frac{f_{slip,nom} [\text{Hz}]}{1[\text{ms}]} \cdot 2[\%] \Rightarrow \Delta f = \frac{2[\%]}{P1203[\%]} \cdot \frac{r0330}{100} \cdot P0310$$

P1203 = 100 % is defined as giving a rate of 2 % of  $f\_slip,nom$  / [ms].

P1203 = 200 % would result in a rate of frequency change of 1 % of  $f\_slip,nom$  / [ms].

**Example:**

For a motor with 50 Hz, 1350 rpm, 100 % would produce a maximum search time of 600 ms. If the motor is turning, the motor frequency is found in a shorter time.

**Note:**

- A higher value produces a flatter gradient and thus a longer search time.
- A lower value has the opposite effect.

<b>r1204</b>	<b>CO/BO: Status word: Flying start</b>	<b>Min:</b> -	<b>Level</b> <b>3</b>	
		<b>Datatype:</b> U16		<b>Unit:</b> -
	<b>P-Group:</b> FUNC			<b>Def:</b> -
		<b>Max:</b> -		

Bit parameter for checking and monitoring states during search, if V/f control mode is selected (see P1300).

**Bitfields:**

Bit00	Current applied	0	NO	1	YES
Bit01	Current could not be applied	0	NO	1	YES
Bit02	Voltage reduced	0	NO	1	YES
Bit03	Slope-filter started	0	NO	1	YES
Bit04	Current less threshold	0	NO	1	YES
Bit05	Current-minimum	0	NO	1	YES
Bit07	Speed could not be found	0	NO	1	YES
Bit08	Flying start active	0	NO	1	YES
Bit09	Flying start selected	0	NO	1	YES

### 3.19 Automatic restart

<b>P1210</b>	<b>Automatic restart</b>			<b>Min:</b> 0	<b>Level</b> <b>2</b>
	<b>CStat:</b> CUT	<b>Datatype:</b> U16	<b>Unit:</b> -	<b>Def:</b> 1	
	<b>P-Group:</b> FUNC	<b>Active:</b> first confirm	<b>QuickComm.:</b> No	<b>Max:</b> 6	

Configures automatic restart function

**Possible Settings:**

- |   |  |                |
|---|--|----------------|
| 0 | Disabled                                       |                |
| 1 | Trip reset after power on,                     | P1211 disabled |
| 2 | Restart after mains blackout,                  | P1211 disabled |
| 3 | Restart after mains brownout or fault,         | P1211 enabled  |
| 4 | Restart after mains brownout,                  | P1211 enabled  |
| 5 | Restart after mains blackout and fault,        | P1211 disabled |
| 6 | Restart after mains brown- /blackout or fault, | P1211 disabled |

**Dependency:**

Automatic restart requires constant ON command via a digital input wire link.



**Caution:**

P1210 > 2 can cause the motor to restart automatically without toggling the ON command !

**Notice:**

A "mains brownout" is where the power is interrupted and re-applied before the display on the BOP (if one is fitted to the inverter) has gone dark (a very short mains break where the DC link has not fully collapsed).

A "mains blackout" is where the display has gone dark (a long mains break where the DC link has fully collapsed) before the power is re-applied.

P1210 = 0:  
Automatic restart is disabled.

P1210 = 1:  
The inverter will acknowledge (reset) faults i.e. it will reset a fault when the is re-applied. This means the inverter must be fully powered down, a brownout is not sufficed. The inverter will not run until the ON command has been toggled.

P1210 = 2:  
The inverter will acknowledge the fault F0003 at power on after blackout and restarts the drive. It is necessary that the ON command is wired via digital input (DIN).

P1210 = 3:  
For these settings it is fundamental that the drive only restarts if it has been in a RUN state at the time of the faults (F0003, etc.). The inverter will acknowledge the fault and restarts the drive after a blackout or brownout. It is necessary that the ON command is wired via digital input (DIN).

P1210 = 4:  
For these settings it is fundamental that the drive only restarts if it has been in a RUN state at the time of the fault (F0003). The inverter will acknowledge the fault and restarts the drive after a blackout or brownout. It is necessary that the ON command is wired via digital input (DIN).

P1210 = 5:  
The inverter will acknowledge the faults F0003 etc. at power on after blackout and restarts the drive. It is necessary that the ON command is wired via digital input (DIN).

P1210 = 6:  
The inverter will acknowledge the faults (F0003 etc.) at power on after blackout or brownout and restarts the drive. It is necessary that the ON command is wired via digital input (DIN). Setting 6 causes the motor to restart immediately.

Following table presents an overview of parameter P1210 and its functionality.

P1210	ON always active (permanent)				ON in no-voltage condition	
	Fault F0003 on Blackout	Fault F0003 on Brownout	All other faults on Blackout	All other faults on Brownout	All faults on Blackout	No faults on Blackout
0	-	-	-	-	-	-
1	Fault acknowl.	-	Fault acknowl.	-	Fault acknowl.	-
2	Fault acknowl. + restart	-	-	-	-	Restart
3	Fault acknowl. + restart	Fault acknowl. + restart	Fault acknowl. + restart	Fault acknowl. + restart	Fault acknowl. + restart	-
4	Fault acknowl. + restart	Fault acknowl. + restart	-	-	-	-
5	Fault acknowl. + restart	-	Fault acknowl. + restart	-	Fault acknowl. + restart	Restart
6	Fault acknowl. + restart	Fault acknowl. + restart	Fault acknowl. + restart	Fault acknowl. + restart	Fault acknowl. + restart	Restart

Flying start must be used in cases where the motor may still be turning (e.g. after a short mains break) or can be driven by the load (P1200).

P1211	<b>Number of restart attempts</b>				Min:	0	Level <b>3</b>
	CStat:	CUT	Datatype:	U16	Unit:	-	
	P-Group:	FUNC	Active:	first confirm	QuickComm.:	No	

Specifies number of times inverter will attempt to restart if automatic restart P1210 is activated.

### 3.20 Motor holding brake

<b>P1215</b>	<b>Holding brake enable</b>	<b>Datatype:</b> U16	<b>Unit:</b> -	<b>Min:</b> 0	<b>Level</b> <b>2</b>
	<b>CStat:</b> T	<b>Active:</b> first confirm	<b>QuickComm.:</b> No	<b>Def:</b> 0	
	<b>P-Group:</b> FUNC			<b>Max:</b> 1	

Enables/disables holding brake function. This function applies the following profile to the inverter:

**ON / OFF1/OFF3:**

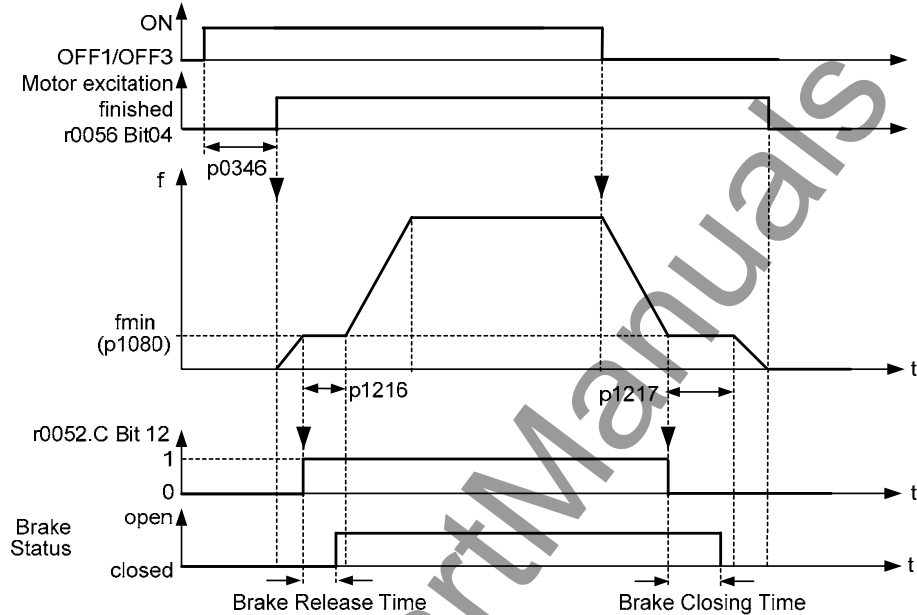

**ON / OFF2:**

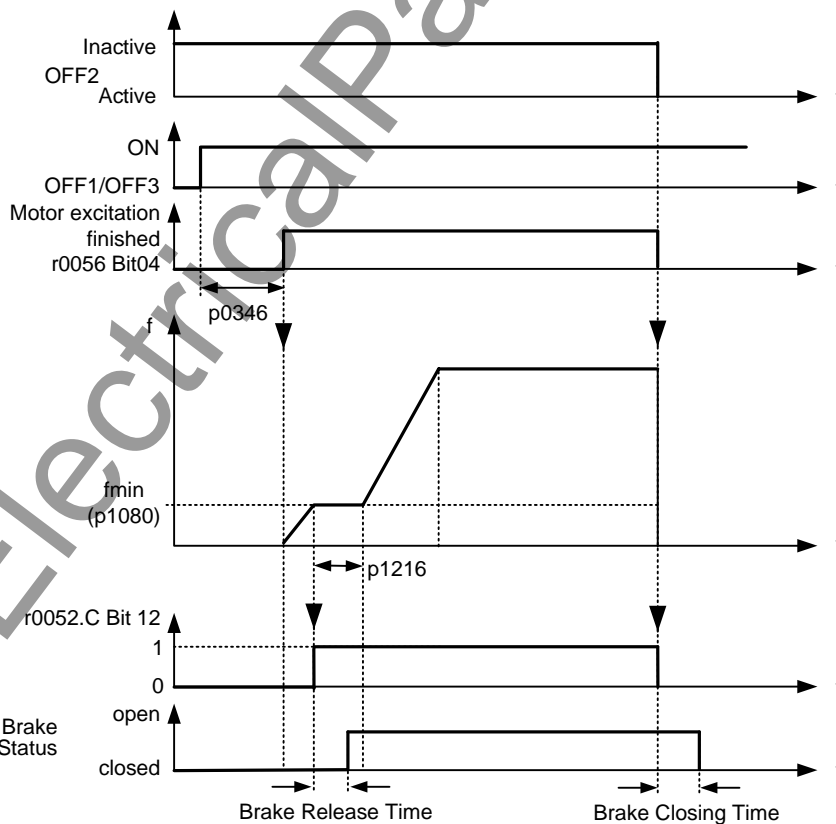

**Possible Settings:**

- 0 Motor holding brake disabled
- 1 Motor holding brake enabled

**Caution:**

1. To activate the motor holding brake, in addition to parameter P1215 = 1, the status signal r0052 bit 12 "motor holding brake active" must be output via a digital output. The user must also select the signal - e.g. in parameter P0731.
2. If the motor holding brake is controlled by the drive inverter, then for potentially hazardous loads (e.g. suspended/hanging loads for crane applications) the drive inverter may not be conditioned unless the load has been secured. Before commissioning, potentially hazardous loads can be secured as follows:
  - lower the load to the floor, or
  - during commissioning or after replacing the drive inverter, prevent the drive inverter from controlling the motor holding brake. Only then should STARTER be used to carry-out a quick commissioning or a parameter download, etc. The motor holding brake terminals can then be re-used (for the motor holding brake, in this case, it is not permissible to parameterize the system so that the digital output P0748 is inverted).
3. In order to hold the motor against the mechanical brake at a certain frequency, it is important that the min. frequency P1080 approximately corresponds to the slip frequency.
  - If the value is selected to be too high, then the current drawn can be too high so that the drive inverter trips (shuts down) due to an overcurrent condition.
  - For a low value, it is possible that the torque cannot be established to hold the load.
4. It is not permissible to use the motor holding brake as operating brake as generally it is only designed and dimensioned for a limited number of emergency braking operations.

**Note:**

Parameter settings:

- To open/close, a digital output controls the motor holding brake at point 1/2 (refer to the diagram). In this case, as prerequisite, the motor holding brake P1215 must be activated as well as the motor holding brake selected at the digital output.
- Brake opening time P1216 greater than/equal to the time for the holding brake to open.
- Brake delay time P1217 greater than/equal to the time to close the holding brake.
- Select the minimum frequency P1080 so that it acts like weight equalization.
- A typical value of the minimum frequency P1080 for the motor holding brake is the slip frequency of the motor r0330. The rated slip frequency can be calculated using the following formula:

$$f_{\text{slip}}[\text{Hz}] = \frac{r0330}{100} \cdot P0310 = \frac{n_{\text{syn}} - n_n}{n_{\text{syn}}} \cdot f_n$$

The following closed-loop control parameters should be observed in conjunction with the motor holding brake:

- P1310, P1311, P1333, P1335 for U/f

<b>P1216</b>	<b>Holding brake release delay</b>	<b>Min:</b> 0.0	<b>Level</b> <b>2</b>	
	<b>CStat:</b> T	<b>Datatype:</b> Float		<b>Unit:</b> s
	<b>P-Group:</b> FUNC	<b>Active:</b> first confirm		<b>QuickComm.:</b> No
		<b>Def:</b> 1.0		
		<b>Max:</b> 20.0		

Defines the brake opening time of the motor holding brake (MHB).

When the motor holding brake (P1215) is activated, then the setpoint enable is delayed by the selected time. The time that it takes to open the mechanical brake is subject to certain fluctuations. This is the reason that the drive inverter applies the min. frequency P1080 to the motor during this time. This means that the brake can reliably open before the motor starts.

$$P1216 \geq \text{Release time of the brake} + \text{relay opening time(s)}$$

**Details:**

See parameter P1215.

<b>P1217</b>	<b>Holding time after ramp down</b>	<b>Min:</b> 0.0	<b>Level</b> <b>2</b>	
	<b>CStat:</b> T	<b>Datatype:</b> Float		<b>Unit:</b> s
	<b>P-Group:</b> FUNC	<b>Active:</b> first confirm		<b>QuickComm.:</b> No
		<b>Def:</b> 1.0		
		<b>Max:</b> 20.0		

Defines the brake delay time of the motor holding brake (MHB).

When the motor holding brake (P1215) is activated, after an off command, the pulse inhibit is delayed by this selected time. The time that it takes to open the mechanical brake is subject to certain fluctuations. This means that after braking to the min. frequency P1080, the motor is held at the minimum frequency for this time. This means that the brake can reliably close before the motor is switched into a no-current condition.

$$P1217 \geq \text{Application time of the brake} + \text{relay closing time}$$

**Details:**

See parameter P1215.

### 3.21 DC braking

<b>P1230</b>	<b>BI: Enable DC braking</b>	<b>Datatype:</b> U32	<b>Unit:</b> -	<b>Min:</b> 0:0	<b>Level</b> <b>3</b>
	<b>CStat:</b> CUT	<b>Active:</b> first confirm	<b>QuickComm.:</b> No	<b>Def:</b> 0:0	
	<b>P-Group:</b> COMMANDS			<b>Max:</b> 4000:0	

Enables DC braking via a signal applied from an external source. Function remains active while external input signal is active.

DC braking causes the motor to stop rapidly by applying a DC braking current (current applied also holds shaft stationary).

When the DC braking signal is applied, the inverter output pulses are blocked and the DC current is not applied until the motor has been sufficiently demagnetized.

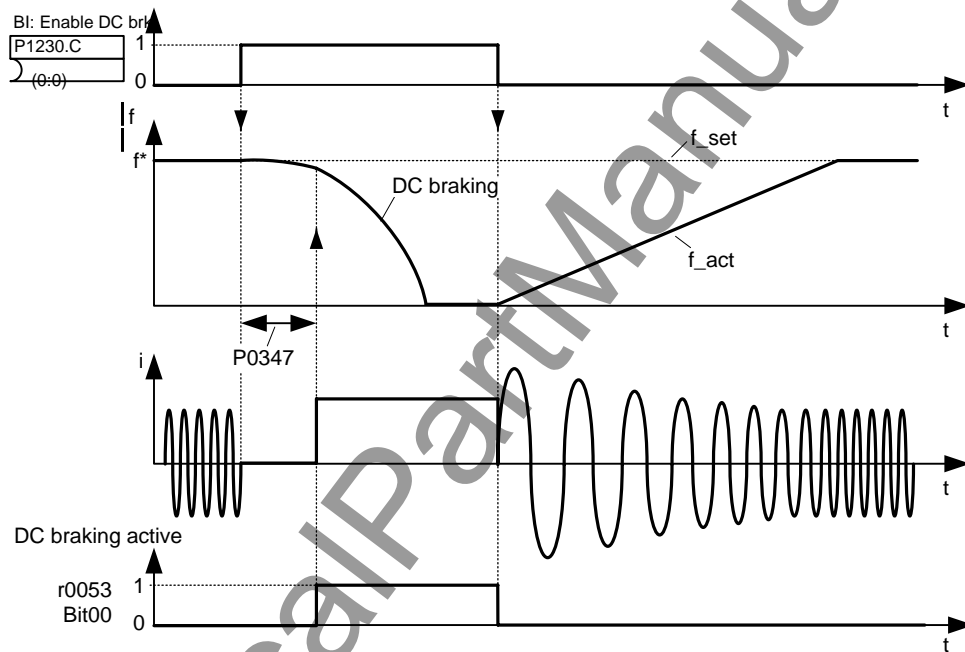

Note: DC brake can be applied in drive states r0002 = 1, 4, 5

The level of DC braking is set in P1232 (DC braking current - relative to the rated motor current) which is set to 100 % by default.

**Common Settings:**

- 722.0 = Digital input 1 (requires P0701 to be set to 99, BICO)
- 722.1 = Digital input 2 (requires P0702 to be set to 99, BICO)
- 722.2 = Digital input 3 (requires P0703 to be set to 99, BICO)
- 722.3 = Digital input 4 (via analog input, requires P0704 to be set to 99)



**Caution:**

With the DC braking, the kinetic energy of the motor is converted into heat in the motor. The drive could overheat if it remains in this status for an excessive period of time !

DC braking is not possible when using a synchronous motor (i.e. P0300 = 2).

**Notice:**

This delay time is set in P0347 (demagnetization time). If this delay is too short, overcurrent trips can occur.

<b>P1232</b>	<b>DC braking current</b>	<b>Datatype:</b> U16	<b>Unit:</b> %	<b>Min:</b> 0	<b>Level</b> <b>2</b>
	<b>CStat:</b> CUT	<b>Active:</b> Immediately	<b>QuickComm.:</b> No	<b>Def:</b> 100	
	<b>P-Group:</b> FUNC			<b>Max:</b> 250	

Defines level of DC current in [%] relative to rated motor current (P0305).

$$r0027_{DC-Brake} [A] = \frac{1}{\sqrt{2}} \cdot P0305 \cdot \frac{P1232}{100 \%}$$

The current of the DC-braking is limited by r0067.

<b>P1233</b>	<b>Duration of DC braking</b>	<b>Datatype:</b> Float	<b>Unit:</b> s	<b>Min:</b> 0.00	<b>Level</b> <b>2</b>
	<b>CStat:</b> CUT	<b>Active:</b> Immediately	<b>QuickComm.:</b> No	<b>Def:</b> 0.00	
	<b>P-Group:</b> FUNC			<b>Max:</b> 250.00	

Defines duration for which DC injection braking is to be active following an OFF1 or OFF3 command. Setting this parameter between 0.01 and 250.00 sets the time duration (in seconds) of the DC injection starting with the OFF1 or OFF3 command.

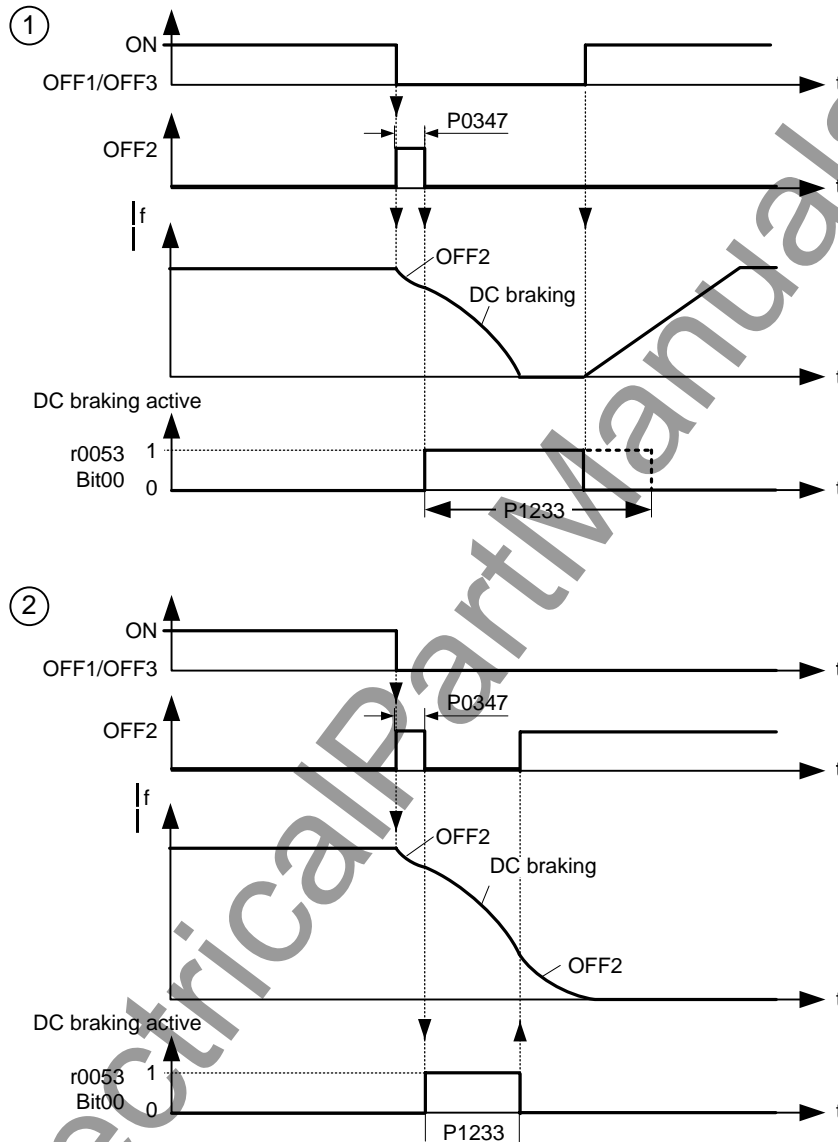

The DC current, that is impressed during time P1233, is specified by parameter P1232.

- Value:**
- P1233 = 0.00 :  
Not active following OFF1 / OFF3.
  - P1233 = 0.01 - 250.00 :  
Active for the specified duration.

**Caution:** With the DC braking, the kinetic energy of the motor is converted into heat in the motor. The drive could overheat if it remains in this status for an excessive period of time !

DC braking is not possible when using a synchronous motor (i.e. P0300 = 2).

**Notice:** The DC braking function causes the motor to stop rapidly by applying a DC braking current (the current applied also holds the shaft stationary). When the DC braking signal is applied, the inverter output pulses are blocked and the DC current not applied until the motor has been sufficiently demagnetized. Demagnetization time is calculated automatically from motor data.

The inverter will not restart if an ON-command is given during this period.

## 3.22 Compound braking

<b>P1236</b>	<b>Compound braking current</b>	<b>Min:</b> 0	<b>Level</b> <b>2</b>	
	<b>CStat:</b> CUT	<b>Datatype:</b> U16		<b>Unit:</b> %
	<b>P-Group:</b> FUNC	<b>Active:</b> Immediately		<b>QuickComm.:</b> No
		<b>Def:</b> 0		
		<b>Max:</b> 250		

Defines DC level superimposed on AC waveform after exceeding DC-link voltage threshold of compound braking. The value is entered in [%] relative to rated motor current (P0305).

If P1254 = 0 :

Compound braking switch-on level

$$U_{DC\_Comp} = 1.13 \cdot \sqrt{2} \cdot V_{mains} = 1.13 \cdot \sqrt{2} \cdot P0210$$

otherwise :

Compound braking switch-on level

$$U_{DC\_Comp} = 0.98 \cdot r1242$$

The Compound Brake is an overlay of the DC brake function with regenerative braking (effective braking at the ramp) after OFF1 or OFF3. This enables braking with controlled motor frequency and a minimum of energy returned to the motor. Through optimization of the ramp-down time and the compound braking an efficient braking without additional HW components is possible.

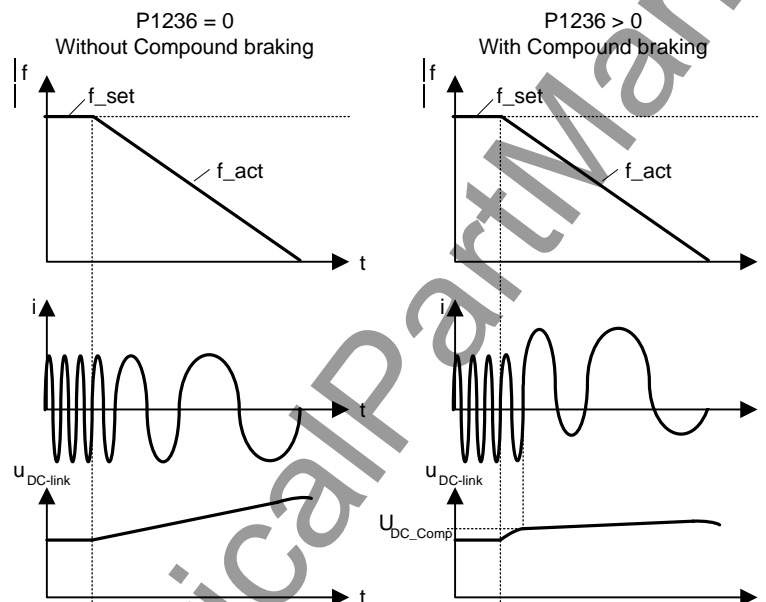

**Value:**

P1236 = 0 :  
Compound braking disabled.

P1236 = 1 - 250 :  
Level of DC braking current defined as a [%] of rated motor current (P0305).

**Dependency:**

Compound braking depends on the DC link voltage only (see threshold above). It will be active with OFF1/OFF3 and at regenerating conditions.

It is disabled, when:

- DC braking is active
- Flying start is active

**Notice:**

Increasing the value will generally improve braking performance; however, if you set the value too high, an overcurrent trip may result. If used with dynamic braking enabled as well compound braking will take priority. If used with the V<sub>dc</sub> max controller enabled the drive behaviour whilst braking may be worsened particularly with high values of compound braking.

### 3.23 Vdc controller

<b>P1240</b>	<b>Configuration of Vdc controller</b>	<b>Min:</b> 0	<b>Level</b>
	<b>CStat:</b> CT <b>Datatype:</b> U16 <b>Unit:</b> - <b>Def:</b> 1	<b>QuickComm.:</b> No	<b>3</b>
	<b>P-Group:</b> FUNC <b>Active:</b> Immediately <b>Max:</b> 1		

Enables / disables Vdc controller.

The Vdc controller dynamically controls the DC link voltage to prevent overvoltage trips on high inertia systems.

**Possible Settings:**

- 0 Vdc controller disabled
- 1 Vdc-max controller enabled

**Note:**

Vdc max controller automatically increases ramp-down times to keep the DC-link voltage (r0026) within limits (r1242).

<b>r1242</b>	<b>CO: Switch-on level of Vdc-max</b>	<b>Min:</b> -	<b>Level</b>
	<b>Datatype:</b> Float <b>Unit:</b> V	<b>Def:</b> -	<b>3</b>
	<b>P-Group:</b> FUNC		

Displays switch-on level of Vdc max controller.

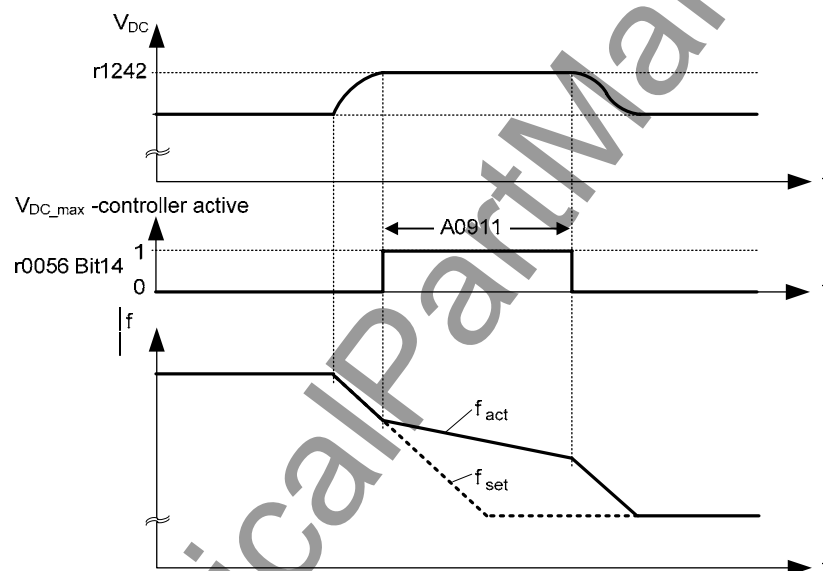

Following equation is only valid, if P1254 = 0 :

$$r1242 = 1.15 \cdot \sqrt{2} \cdot V_{mains} = 1.15 \cdot \sqrt{2} \cdot P0210$$

otherwise :

r1242 is internally calculated

**Note:**

Parameter r1242 (switch-in threshold) is determined by each power cycle, when precharging of the DC-link is finished.

<b>P1243</b>	<b>Dynamic factor of Vdc-max</b>	<b>Min:</b> 10	<b>Level</b>
	<b>CStat:</b> CUT <b>Datatype:</b> U16 <b>Unit:</b> % <b>Def:</b> 100	<b>QuickComm.:</b> No	<b>3</b>
	<b>P-Group:</b> FUNC <b>Active:</b> Immediately <b>Max:</b> 200		

Defines dynamic factor for DC link controller in [%].

**Dependency:**

P1243 = 100 % means parameters P1250, P1251 and P1252 (gain, integration time and differential time) are used as set. Otherwise, these are multiplied by P1243 (dynamic factor of Vdc-max).

**Note:**

Vdc controller adjustment is calculated automatically from motor and inverter data.

<b>P1250</b>	<b>Gain of Vdc-controller</b>	<b>Min:</b> 0.00	<b>Level</b>
	<b>CStat:</b> CUT <b>Datatype:</b> Float <b>Unit:</b> - <b>Def:</b> 1.00	<b>QuickComm.:</b> No	<b>4</b>
	<b>P-Group:</b> FUNC <b>Active:</b> Immediately <b>Max:</b> 10.00		

Enters gain for Vdc controller.

<b>P1251</b>	<b>Integration time Vdc-controller</b>				Level <b>4</b>
	<b>CStat:</b> CUT	<b>Datatype:</b> Float	<b>Unit:</b> ms	<b>Min:</b> 0.1 <b>Def:</b> 40.0	
	<b>P-Group:</b> FUNC	<b>Active:</b> Immediately	<b>QuickComm.:</b> No	<b>Max:</b> 1000.0	

Enters integral time constant for Vdc controller.

<b>P1252</b>	<b>Differential time Vdc-controller</b>				Level <b>4</b>
	<b>CStat:</b> CUT	<b>Datatype:</b> Float	<b>Unit:</b> ms	<b>Min:</b> 0.0 <b>Def:</b> 1.0	
	<b>P-Group:</b> FUNC	<b>Active:</b> Immediately	<b>QuickComm.:</b> No	<b>Max:</b> 1000.0	

Enters differential time constant for Vdc controller.

<b>P1253</b>	<b>Vdc-controller output limitation</b>				Level <b>3</b>
	<b>CStat:</b> CUT	<b>Datatype:</b> Float	<b>Unit:</b> Hz	<b>Min:</b> 0.00 <b>Def:</b> 10.00	
	<b>P-Group:</b> FUNC	<b>Active:</b> Immediately	<b>QuickComm.:</b> No	<b>Max:</b> 600.00	

Limits maximum effect of Vdc max controller.

<b>P1254</b>	<b>Auto detect Vdc switch-on levels</b>				Level <b>3</b>
	<b>CStat:</b> CT	<b>Datatype:</b> U16	<b>Unit:</b> -	<b>Min:</b> 0 <b>Def:</b> 1	
	<b>P-Group:</b> FUNC	<b>Active:</b> Immediately	<b>QuickComm.:</b> No	<b>Max:</b> 1	

Enables/disables auto-detection of switch-on levels for Vdc control functionalities.

Following switch-on levels are calculated

- Switch-on level compound brake
- Switch-on level Vdc\_max controller r1242

**Possible Settings:**

- 0 Disabled
- 1 Enabled

**Note:**

The switch-on thresholds are only calculated during the start-up of the inverter after connection to the mains. An online-adaption is not performed during operation. This means that modification of P1254 does not immediately take effect and variations in the mains are also not initially taken into account.

P1254 = 0 (Automatic Detection disabled):

The above thresholds are calculated via P0210, if automatic detection is disabled.

### 3.24 Control mode

<b>P1300</b>	<b>Control mode</b>	<b>Datatype:</b> U16	<b>Unit:</b> -	<b>Min:</b> 0	<b>Level</b> <b>2</b>
	<b>CStat:</b> CT	<b>Active:</b> first confirm	<b>QuickComm.:</b> Yes	<b>Def:</b> 0	
	<b>P-Group:</b> CONTROL			<b>Max:</b> 3	

Controls relationship between speed of motor and voltage supplied by inverter as illustrated in the diagram below.

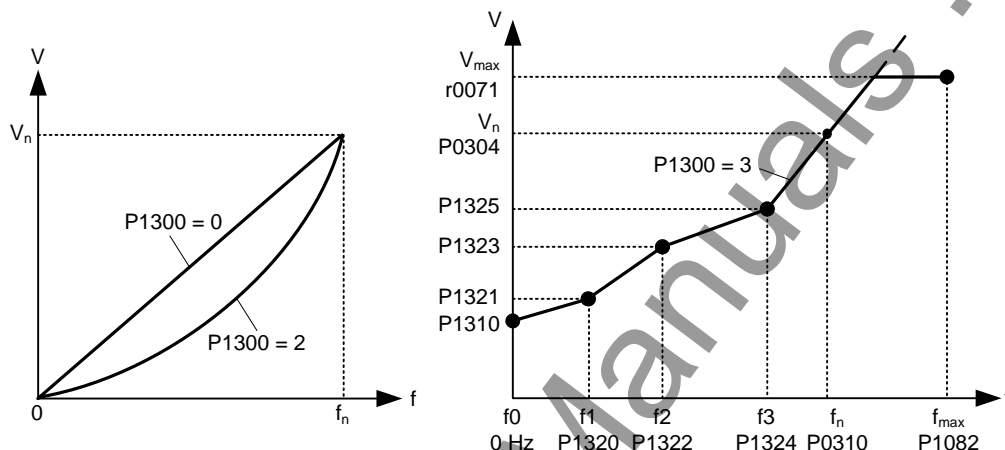

- Possible Settings:**
- 0 V/f with linear characteristic
  - 1 V/f with FCC
  - 2 V/f with parabolic characteristic
  - 3 V/f with programmable characteristic

**Note:**

P1300 = 1 : V/f with FCC (flux current control)  
 - Maintains motor flux current for improved efficiency.  
 - If FCC is chosen, linear V/f is active at low frequencies.

P1300 = 2 : V/f with a quadratic characteristic  
 - Suitable for centrifugal fans / pumps

P1300 = 3 : V/f with a programmable characteristic  
 - User defined characteristic (see P1320)  
 - For synchronous motors (e.g. SIEMOSYN motors)

The following table presents an overview of control parameters (V/f) that can be modify in relationship to P1300 dependencies:

ParNo.	Parameter name	Level	V/f			
			P1300 =			
			0	1	2	3
P1300	Control mode	2	x	x	x	x
P1310	Continuous boost	2	x	x	x	x
P1311	Acceleration boost	2	x	x	x	x
P1312	Starting boost	2	x	x	x	x
P1316	Boost end frequency	3	x	x	x	x
P1320	Programmable V/f freq. coord. 1	3	-	-	-	x
P1321	Programmable V/f volt. coord. 1	3	-	-	-	x
P1322	Programmable V/f freq. coord. 2	3	-	-	-	x
P1323	Programmable V/f volt. coord. 2	3	-	-	-	x
P1324	Programmable V/f freq. coord. 3	3	-	-	-	x
P1325	Programmable V/f volt. coord. 3	3	-	-	-	x
P1333	Start frequency for FCC	3	-	x	-	-
P1335	Slip compensation	2	x	x	x	x
P1336	CO: U/f Slip limit	2	x	x	x	x
P1338	Resonance damping gain V/f	3	x	x	x	x
P1340	I <sub>max</sub> freq. controller prop. gain	3	x	x	x	x
P1341	I <sub>max</sub> controller integral time	3	x	x	x	x
P1345	I <sub>max</sub> controller prop. gain	3	x	x	x	x
P1346	I <sub>max</sub> voltage ctrl. integral time	3	x	x	x	x
P1350	Voltage soft start	3	x	x	x	x

### 3.25 V/f control parameters

<b>P1310</b>	<b>Continuous boost</b>	<b>Datatype:</b> Float	<b>Unit:</b> %	<b>Min:</b> 0.0	<b>Level</b> <b>2</b>
	<b>CStat:</b> CUT	<b>Active:</b> Immediately	<b>QuickComm.:</b> No	<b>Def:</b> 50.0	
	<b>P-Group:</b> CONTROL			<b>Max:</b> 250.0	

P1310 causes a voltage boost depending on the output frequency (see diagram). At low output frequencies the output voltage is low to keep the flux level constant. However, the output voltage may be too low

- for magnetisation the asynchronous motor
- to hold the load
- to overcome losses in the system.

To compensate these effects, the output voltage can be increased using parameter P1310.

Defines boost level in [%] relative to P0305 (rated motor current) applicable to both linear and quadratic V/f curves according to the diagram below:

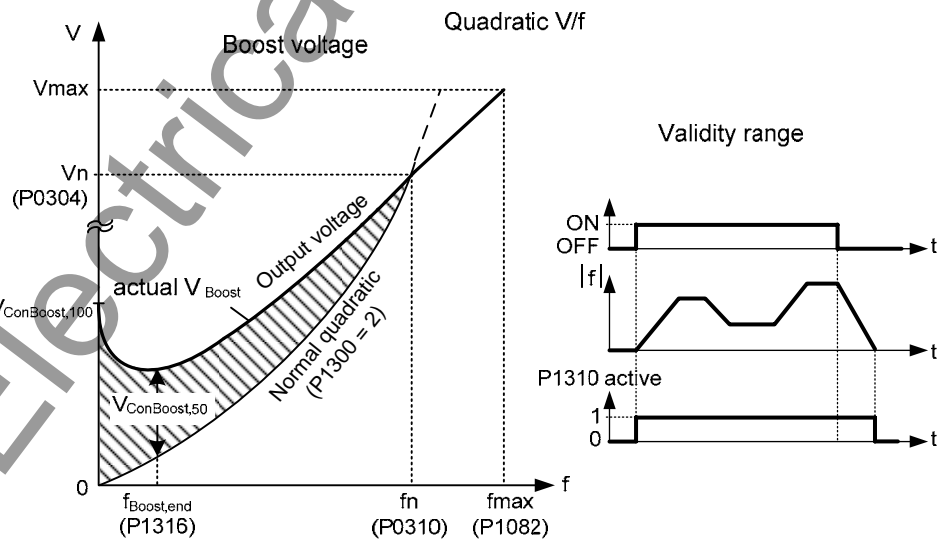
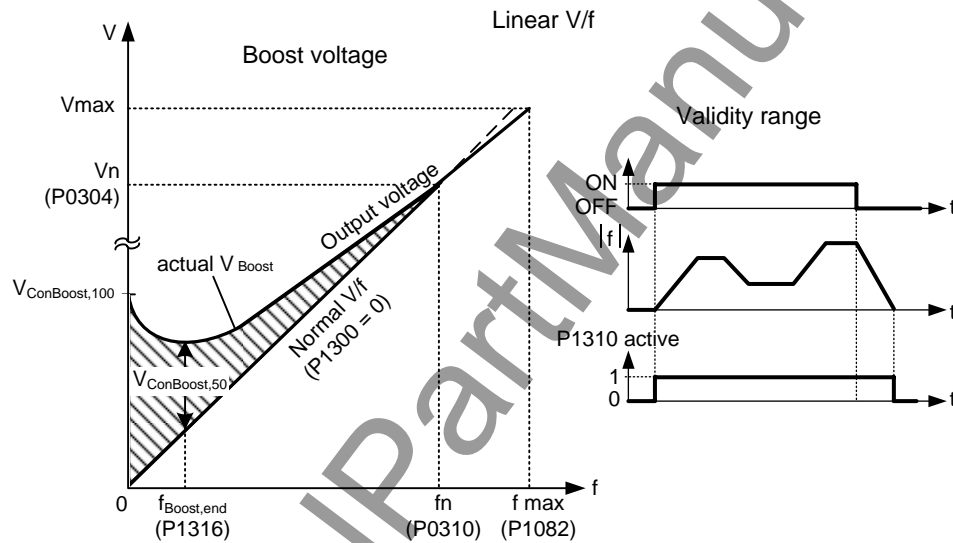

where voltage values are given

$$V_{ConBoost,100} = P0305 \cdot P0350 \cdot \frac{P1310}{100}$$

$$V_{ConBoost,50} = \frac{V_{ConBoost,100}}{2}$$

**Note:**

- Increasing the boost levels increases motor heating (especially at standstill).

- The boost values are combined when continuous boost (P1310) used in conjunction with other boost parameters (acceleration boost P1311 and starting boost P1312).
- However priorities are allocated to these parameters as follows:  
P1310 > P1311 > P1312

- The total boost is limited by following equation:

$$\sum V_{Boost} \leq 3 \cdot R_s \cdot I_{Mot} = 3 \cdot P0305 \cdot P0350$$

- Setting in P0640 (motor overload factor [%]) limits the boost:

$$\frac{\sum V_{Boost}}{P0305 \cdot P0350} \leq \frac{P0640}{100}$$

<b>P1311</b>	<b>Acceleration boost</b>			<b>Min:</b> 0.0	<b>Level</b> <b>2</b>
	<b>CStat:</b> CUT	<b>Datatype:</b> Float	<b>Unit:</b> %	<b>Def:</b> 0.0	
	<b>P-Group:</b> CONTROL	<b>Active:</b> Immediately	<b>QuickComm.:</b> No	<b>Max:</b> 250.0	

P1311 will only produce boost during ramping, and is therefore useful for additional torque during acceleration and deceleration. Contrary to P1312, that is only active when an ON command is given, p1311 is active after each acceleration resp. deceleration. The boost is active, if P1311 > 0 resp. if the conditions given below are fulfilled.

Applies boost in [%] relative to P0305 (rated motor current) following a positive setpoint change and drops back out once the setpoint is reached. It is activated when the setpoint changes and deactivated when the setpoint is reached.

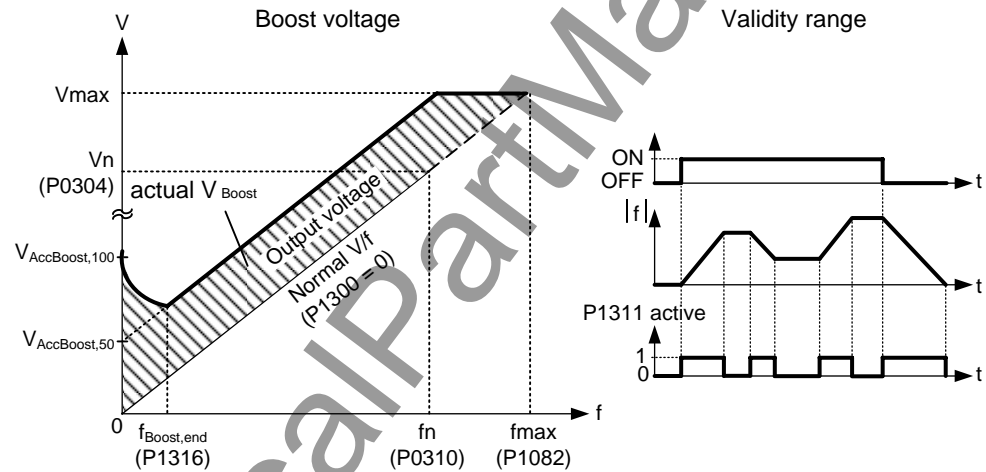

where voltage values are given

$$V_{AccBoost,100} = P0305 \cdot P0350 \cdot \frac{P1311}{100}$$

$$V_{AccBoost,50} = \frac{V_{AccBoost,100}}{2}$$

**Note:** See parameter P1310

<b>P1312</b>	<b>Starting boost</b>			<b>Min:</b> 0.0	<b>Level</b> <b>2</b>
	<b>CStat:</b> CUT	<b>Datatype:</b> Float	<b>Unit:</b> %	<b>Def:</b> 0.0	
	<b>P-Group:</b> CONTROL	<b>Active:</b> Immediately	<b>QuickComm.:</b> No	<b>Max:</b> 250.0	

Applies a constant linear offset (in [%] relative to P0305 (rated motor current)) to active V/f curve (either linear or quadratic) after an ON command and is active until  
 1) ramp output reaches setpoint for the first time respectively  
 2) setpoint is reduced to less than present ramp output

This is useful for starting loads with high inertia.

Setting the starting boost (P1312) too high will cause the inverter to limit the current, which will in turn restrict the output frequency to below the setpoint frequency.

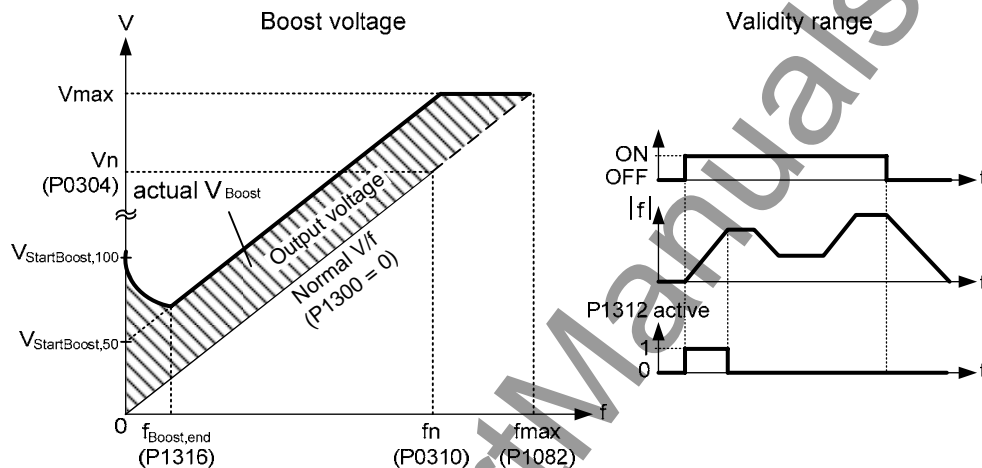

where voltage values are given

$$V_{StartBoost,100} = P0305 \cdot P0350 \cdot \frac{P1312}{100}$$

$$V_{StartBoost,50} = \frac{V_{StartBoost,100}}{2}$$

**Example:**

Setpoint = 50Hz. Ramping up with starting boost. During ramp up, setpoint changed to 20Hz. As soon as setpoint changed, starting boost removed because setpoint smaller than present ramp output.

**Note:**

See parameter P1310

<b>r1315</b>	<b>CO: Total boost voltage</b>			<b>Min:</b> -	<b>Level</b> <b>4</b>
	<b>P-Group:</b> CONTROL	<b>Datatype:</b> Float	<b>Unit:</b> V	<b>Def:</b> -	
				<b>Max:</b> -	

Displays total value of voltage boost (in volts).

<b>P1316</b>	<b>Boost end frequency</b>			<b>Min:</b> 0.0	<b>Level</b> <b>3</b>
	<b>CStat:</b> CUT	<b>Datatype:</b> Float	<b>Unit:</b> %	<b>Def:</b> 20.0	
	<b>P-Group:</b> CONTROL	<b>Active:</b> Immediately	<b>QuickComm.:</b> No	<b>Max:</b> 100.0	

Defines point at which programmed boost reaches 50 % of its value. This value is expressed in [%] relative to P0310 (rated motor frequency).

The default frequency is defined as follows:

$$f_{Boost\ min} = 2 \cdot \left( \frac{153}{\sqrt{P_{motor}}} + 3 \right)$$

**Note:**

- The expert user may change this value to alter the shape of the curve, e.g. to increase torque at a particular frequency.
- Default value is depending on inverter type and its rating data.

**Details:**

See diagram in P1310 (continuous boost).

<b>P1320</b>	<b>Programmable V/f freq. coord. 1</b>	<b>Min:</b> 0.00	<b>Level</b> <b>3</b>
	<b>CStat:</b> CT <b>Datatype:</b> Float <b>Unit:</b> Hz <b>Def:</b> 0.00		
	<b>P-Group:</b> CONTROL <b>Active:</b> Immediately <b>QuickComm.:</b> No <b>Max:</b> 650.00		

Sets V/f coordinates (P1320/1321 to P1324/1325) to define V/f characteristic.

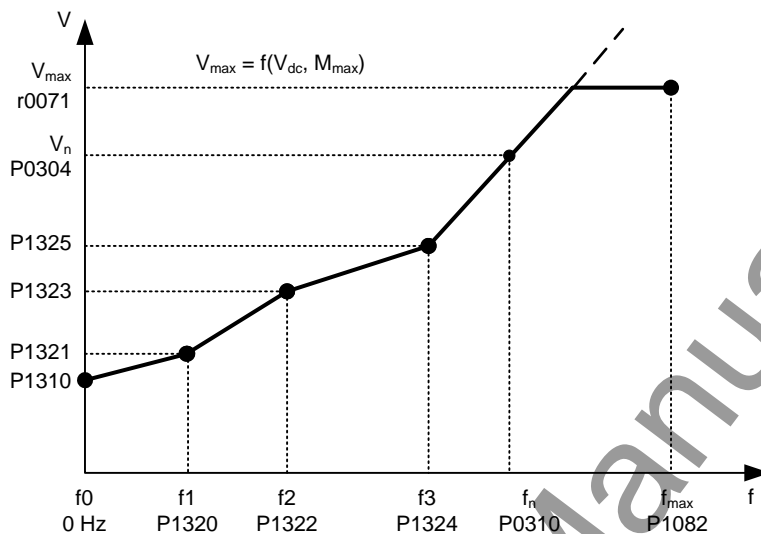

$$P1310[V] = \frac{P1310[\%]}{100[\%]} \cdot \frac{r0395[\%]}{100[\%]} \cdot P0304[V]$$

**Example:**

This parameter can be used to provide correct torque at correct frequency and is useful when used with synchronous motors.

**Dependency:**

To set parameter, select P1300 = 3 (V/f with programmable characteristic).

**Note:**

Linear interpolation will be applied between the individual data points.

V/f with programmable characteristic (P1300 = 3) has 3 programmable points. The two non-programmable points are:

- Continuous boost P1310 at zero 0 Hz
- Rated motor voltage P0304 at rated motor frequency P0310

The acceleration boost and starting boost defined in P1311 and P1312 are applied to V/f with programmable characteristic.

<b>P1321</b>	<b>Programmable V/f volt. coord. 1</b>	<b>Min:</b> 0.0	<b>Level</b> <b>3</b>
	<b>CStat:</b> CUT <b>Datatype:</b> Float <b>Unit:</b> V <b>Def:</b> 0.0		
	<b>P-Group:</b> CONTROL <b>Active:</b> Immediately <b>QuickComm.:</b> No <b>Max:</b> 3000.0		

See P1320 (programmable V/f freq. coord. 1).

<b>P1322</b>	<b>Programmable V/f freq. coord. 2</b>	<b>Min:</b> 0.00	<b>Level</b> <b>3</b>
	<b>CStat:</b> CT <b>Datatype:</b> Float <b>Unit:</b> Hz <b>Def:</b> 0.00		
	<b>P-Group:</b> CONTROL <b>Active:</b> Immediately <b>QuickComm.:</b> No <b>Max:</b> 650.00		

See P1320 (programmable V/f freq. coord. 1).

<b>P1323</b>	<b>Programmable V/f volt. coord. 2</b>	<b>Min:</b> 0.0	<b>Level</b> <b>3</b>
	<b>CStat:</b> CUT <b>Datatype:</b> Float <b>Unit:</b> V <b>Def:</b> 0.0		
	<b>P-Group:</b> CONTROL <b>Active:</b> Immediately <b>QuickComm.:</b> No <b>Max:</b> 3000.0		

See P1320 (programmable V/f freq. coord. 1).

<b>P1324</b>	<b>Programmable V/f freq. coord. 3</b>	<b>Min:</b> 0.00	<b>Level</b> <b>3</b>
	<b>CStat:</b> CT <b>Datatype:</b> Float <b>Unit:</b> Hz <b>Def:</b> 0.00		
	<b>P-Group:</b> CONTROL <b>Active:</b> Immediately <b>QuickComm.:</b> No <b>Max:</b> 650.00		

See P1320 (programmable V/f freq. coord. 1).

<b>P1325</b>	<b>Programmable V/f volt. coord. 3</b>	<b>Min:</b> 0.0	<b>Level</b> <b>3</b>
	<b>CStat:</b> CUT <b>Datatype:</b> Float <b>Unit:</b> V <b>Def:</b> 0.0		
	<b>P-Group:</b> CONTROL <b>Active:</b> Immediately <b>QuickComm.:</b> No <b>Max:</b> 3000.0		

See P1320 (programmable V/f freq. coord. 1).

<b>P1333</b>	<b>Start frequency for FCC</b>			<b>Min:</b> 0.0	<b>Level</b> <b>3</b>
	<b>CStat:</b> CUT	<b>Datatype:</b> Float	<b>Unit:</b> %	<b>Def:</b> 10.0	
	<b>P-Group:</b> CONTROL	<b>Active:</b> Immediately	<b>QuickComm.:</b> No	<b>Max:</b> 100.0	

Defines the FCC starting frequency as a percentage of the rated motor frequency (P0310).

When FCC is activated using P1300 = 1, then as a function of the FCC starting frequency plus hysteresis and the actual frequency, a changeover is made with a continuous transition between the linear V/f characteristic (P1300 = 0) and FCC (refer to the diagram).

$$f_{FCC} = \frac{P0310}{100} \cdot P1333$$

$$f_{FCC+Hys} = \frac{P0310}{100} \cdot (P1333 + 6\%)$$

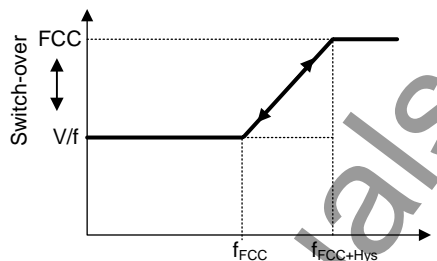

**Notice:**

- A value that is excessively low can result in instability.
- The constant voltage boost P1310 is continuously de-activated - essentially the same as when switching-in FCC.
- Contrary, the voltage boosts P1311 and P1312 remain active over the complete frequency range.

### 3.25.1 Slip compensation

<b>P1335</b>	<b>Slip compensation</b>	<b>Datatype:</b> Float	<b>Unit:</b> %	<b>Min:</b> 0.0	<b>Level</b> <b>2</b>
	<b>CStat:</b> CUT <b>P-Group:</b> CONTROL	<b>Active:</b> Immediately	<b>QuickComm.:</b> No	<b>Def:</b> 0.0 <b>Max:</b> 600.0	

Dynamically adjusts output frequency of inverter so that motor speed is kept constant independent of motor load.

In the V/f-control, the motor speed will always be less than the command speed due to the slip speed. For a given speed command, the speed will drop as load is increased. The speed regulation of drive can be improved by the technique known as slip compensation.

Increasing the load from M1 to M2 (see diagram) will decrease the motor speed from f1 to f2, due to the slip. The inverter can compensate for this by increasing the output frequency slightly as the load increases. The inverter measures the current and increases the output frequency to compensate for the expected slip.

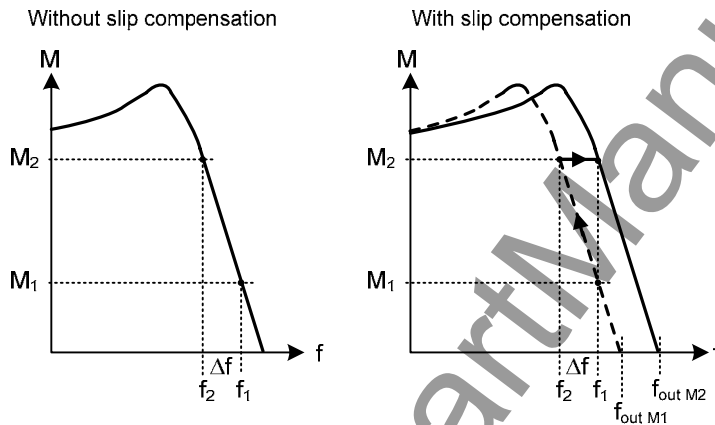

**Value:**

P1335 = 0 % :  
Slip compensation disabled.

P1335 = 50 % - 70 % :  
Full slip compensation at cold motor (partial load).

P1335 = 100 % :  
Full slip compensation at warm motor (full load).

Range of slip compensation :

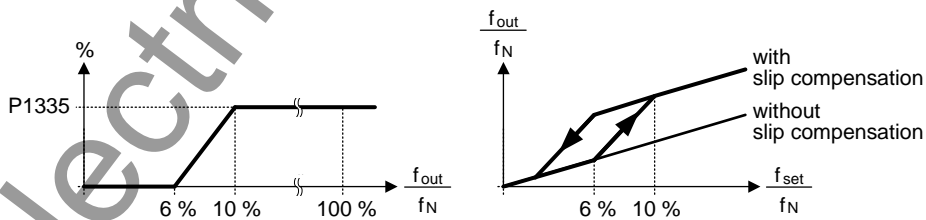

**Notice:**

The applied value of the slip compensation (scaled by P1335) is limited by following equation:

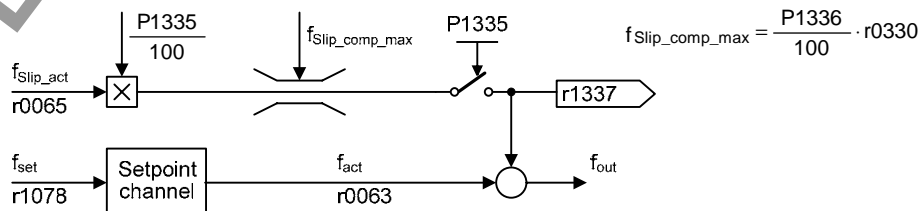

<b>P1336</b>	<b>Slip limit</b>			<b>Min:</b> 0	Level
	<b>CStat:</b> CUT	<b>Datatype:</b> U16	<b>Unit:</b> %	<b>Def:</b> 250	<b>2</b>
	<b>P-Group:</b> CONTROL	<b>Active:</b> Immediately	<b>QuickComm.:</b> No	<b>Max:</b> 600	

Compensation slip limit in [%] relative to r0330 (rated motor slip), which is added to frequency setpoint.

**Dependency:**

Slip compensation (P1335) active.

<b>r1337</b>	<b>CO: V/f slip frequency</b>			<b>Min:</b> -	Level
		<b>Datatype:</b> Float	<b>Unit:</b> %	<b>Def:</b> -	<b>3</b>
	<b>P-Group:</b> CONTROL			<b>Max:</b> -	

Displays actual compensated motor slip as [%]

**Dependency:**

Slip compensation (P1335) active.

### 3.25.2 Resonance damping

<b>P1338</b>	<b>Resonance damping gain V/f</b>			<b>Min:</b> 0.00	Level
	<b>CStat:</b> CUT	<b>Datatype:</b> Float	<b>Unit:</b> -	<b>Def:</b> 0.00	<b>3</b>
	<b>P-Group:</b> CONTROL	<b>Active:</b> Immediately	<b>QuickComm.:</b> No	<b>Max:</b> 10.00	

Defines resonance damping gain for V/f. Here,  $di/dt$  of the active current will be scaled by P1338 (see diagram below). If  $di/dt$  increases the resonance damping circuit decreases the inverter output frequency.

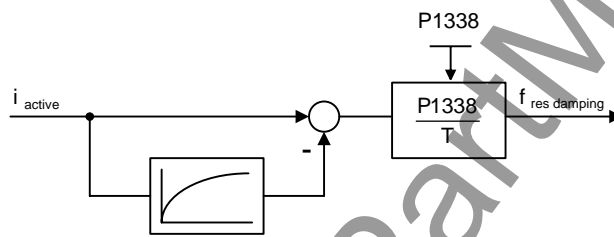
**Note:**

- The resonance damping function is used to dampen oscillations in the active current. These especially occur when rotating field motors are operating under no-load conditions. The parameter is not used to optimize the stabilizing behavior.
- In the V/f control modes (refer to P1300), the resonance damping controller is activate in a range from approximately 5 % up to 70 % of the rated motor frequency (P0310).
- An excessively high value results in instability (positive feedback).

### 3.25.3 I<sub>max</sub> controller

<b>P1340</b>	<b>I<sub>max</sub> controller prop. gain</b>			<b>Min:</b> 0.000	<b>Level</b> <b>3</b>
	<b>CStat:</b> CUT	<b>Datatype:</b> Float	<b>Unit:</b> -	<b>Def:</b> 0.000	
	<b>P-Group:</b> CONTROL	<b>Active:</b> Immediately	<b>QuickComm.:</b> No	<b>Max:</b> 0.499	

Proportional gain of the I<sub>max</sub> frequency controller.

Dynamically controls the inverter if the output current exceeds the maximum motor current (r0067). It does this by first limiting the inverter output frequency (to a possible minimum of the nominal slip frequency). If this action does not successfully remove the overcurrent condition, the inverter output voltage is reduced. When the overcurrent condition has been removed successfully, frequency limiting is removed using the ramp-up time set in P1120.

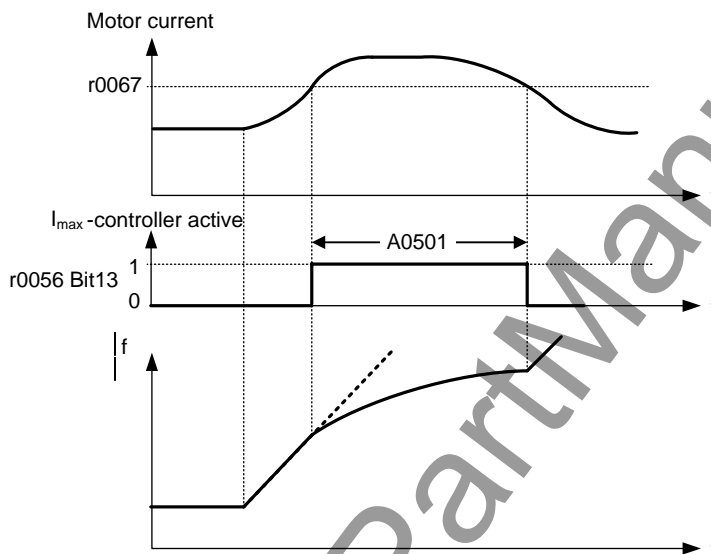

<b>P1341</b>	<b>I<sub>max</sub> controller integral time</b>			<b>Min:</b> 0.000	<b>Level</b> <b>3</b>
	<b>CStat:</b> CUT	<b>Datatype:</b> Float	<b>Unit:</b> s	<b>Def:</b> 0.300	
	<b>P-Group:</b> CONTROL	<b>Active:</b> Immediately	<b>QuickComm.:</b> No	<b>Max:</b> 50.000	

Integral time constant of the I<sub>max</sub> controller.

P1341 = 0 :  
I<sub>max</sub> controller disabled

P1340 = 0 and P1341 > 0 :  
enhanced integral

P1340 > 0 and P1341 > 0 :  
normal PI control

See description in parameter P1340 for further information.

<b>r1343</b>	<b>CO: I<sub>max</sub> controller freq. output</b>			<b>Min:</b> -	<b>Level</b> <b>3</b>
		<b>Datatype:</b> Float	<b>Unit:</b> Hz	<b>Def:</b> -	
	<b>P-Group:</b> CONTROL			<b>Max:</b> -	

Displays effective frequency limitation.

**Dependency:**

If I<sub>max</sub> controller not in operation, parameter normally shows max. frequency P1082.

<b>r1344</b>	<b>CO: I<sub>max</sub> controller volt. output</b>			<b>Min:</b> -	<b>Level</b> <b>3</b>
		<b>Datatype:</b> Float	<b>Unit:</b> V	<b>Def:</b> -	
	<b>P-Group:</b> CONTROL			<b>Max:</b> -	

Displays amount by which the I<sub>max</sub> controller is reducing the inverter output voltage.

<b>P1349</b>	<b>Resonance damping limit</b>				<b>Min:</b> 80.0	<b>Level</b> <b>3</b>
	<b>CStat:</b> CUT	<b>Datatype:</b> Float	<b>Unit:</b> %	<b>Def:</b> 80.0		
	<b>P-Group:</b> CONTROL	<b>Active:</b> Immediately	<b>QuickComm.:</b> No	<b>Max:</b> 100.0		

Defines the upper limit at which resonance damping is active for V/f.

**Note:**

The resonance circuit damps oscillations of the active current which frequently occur during no-load operation (see P1338).

The limit is defined as a percentage of rated motor frequency (P0310). There is a 5% band below the upper limit through which the gain decreases in a linear fashion from full gain to zero gain.

### 3.25.4 Soft starting

<b>P1350</b>	<b>Voltage soft start</b>				<b>Min:</b> 0	<b>Level</b> <b>3</b>
	<b>CStat:</b> CUT	<b>Datatype:</b> U16	<b>Unit:</b> -	<b>Def:</b> 0		
	<b>P-Group:</b> CONTROL	<b>Active:</b> first confirm	<b>QuickComm.:</b> No	<b>Max:</b> 1		

Selecting the soft starting function.

With soft starting, the flux in the motor is established with some delay. This ensures that the motor only rotates in the required direction of rotation even with existing residual magnetism. When activated, at powered-on, the output voltage is ramped-up to the value of the characteristic voltage within the magnetizing time P0346.

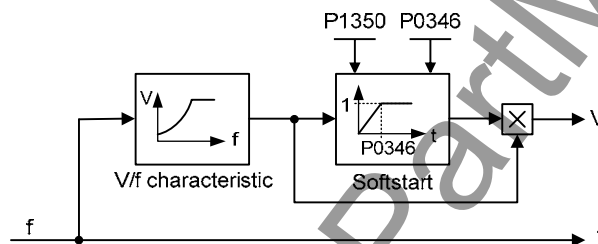
**Possible Settings:**

- 0 OFF
- 1 ON

**Note:**

The settings for this parameter bring benefits and drawbacks:

- P1350 = 0: (jump to boost voltage)  
Benefit: flux is built up quickly  
Drawback: motor may move
- P1350 = 1: (smooth voltage build-up)  
Benefit: motor less likely to move  
Drawback: flux build-up takes longer

## 3.26 Inverter parameters (Modulator)

<b>P1800</b>	<b>Pulse frequency</b>	<b>Min:</b> 2	Level <b>2</b>	
	<b>CStat:</b> CUT	<b>Datatype:</b> U16		<b>Unit:</b> kHz
	<b>P-Group:</b> INVERTER	<b>Active:</b> Immediately		<b>QuickComm.:</b> No
Sets pulse frequency of power switches in inverter. The frequency can be changed in steps of 2 kHz.				
<b>Dependency:</b>				
Minimum pulse frequency depends on P1082 (maximum frequency) and P0310 (rated motor frequency).				
- see derating in P1082				
- $P1800 > 30 * P0310$				
<b>Note:</b>				
- If the pulse frequency is increased, max. inverter current r0209 can be reduced (derating). The derating characteristic depends on the type and power of the inverter (see manual OPERATING INSTRUCTION).				
- If silent operation is not absolutely necessary, lower pulse frequencies may be selected to reduce inverter losses and radio-frequency emissions.				
- Under certain circumstances, the inverter may reduce the switching frequency to provide protection against over-temperature (see P0290).				
<b>r1801</b>	<b>CO: Act. pulse frequency</b>	<b>Min:</b> -	Level <b>3</b>	
	<b>Datatype:</b> U16	<b>Unit:</b> kHz		<b>Def:</b> -
	<b>P-Group:</b> INVERTER	<b>Active:</b> -		<b>Max:</b> -
Actual pulse frequency of power switches in inverter.				
<b>Notice:</b>				
Under certain conditions (inverter overtemperature, see P0290), this can differ from the values selected in P1800 (pulse frequency).				
<b>P1802</b>	<b>Modulator mode</b>	<b>Min:</b> 0	Level <b>3</b>	
	<b>CStat:</b> CUT	<b>Datatype:</b> U16		<b>Unit:</b> -
	<b>P-Group:</b> INVERTER	<b>Active:</b> first confirm		<b>QuickComm.:</b> No
Selects inverter modulator mode.				
<b>Possible Settings:</b>				
0 SVM/ASVM automatic mode				
1 Asymmetric SVM				
2 Space vector modulation				
<b>Notice:</b>				
- Asymmetric space vector modulation (ASVM) produces lower switching losses than space vector modulation (SVM), but may cause irregular rotation at very low frequencies.				
- Space vector modulation (SVM) with over-modulation may produce current waveform distortion at high output voltages.				
- Space vector modulation (SVM) without over-modulation will reduce maximum output voltage available to motor.				
<b>P1803</b>	<b>Max. modulation</b>	<b>Min:</b> 20.0	Level <b>4</b>	
	<b>CStat:</b> CUT	<b>Datatype:</b> Float		<b>Unit:</b> %
	<b>P-Group:</b> INVERTER	<b>Active:</b> Immediately		<b>QuickComm.:</b> No
Sets maximum modulation index.				
<b>Note:</b>				
- $P1803 = 100\%$ : Limit for over-control (for ideal inverter without switching delay).				
<b>P1820</b>	<b>Reverse output phase sequence</b>	<b>Min:</b> 0	Level <b>2</b>	
	<b>CStat:</b> CT	<b>Datatype:</b> U16		<b>Unit:</b> -
	<b>P-Group:</b> INVERTER	<b>Active:</b> first confirm		<b>QuickComm.:</b> No
Changes direction of motor rotation without changing setpoint polarity.				
<b>Possible Settings:</b>				
0 OFF				
1 ON				
<b>Dependency:</b>				
If positive and negative revolution is enabled, frequency setpoint is directly used.				
If both positive and negative revolution are disabled, reference value is set to zero.				
<b>Details:</b>				
See P1000 (select frequency setpoint)				

### 3.27 Motor data identification

<b>P1910</b>	<b>Select motor data identification</b>				Min: 0	Level <b>2</b>
	CStat: CT	Datatype: U16	Unit: -	Def: 0		
	P-Group: MOTOR	Active: first confirm	QuickComm.: Yes	Max: 2		

Performs a motor data identification.

Performs stator resistance measuring.

**Possible Settings:**

- 0 Disabled
- 1 Identification of Rs with parameter change
- 2 Identification of Rs without parameter change

**Dependency:**

No measurement if motor data incorrect.

P1910 = 1 : Calculated value for stator resistance (see P0350) is overwritten.

P1910 = 2 : Values already calculated are not overwritten.

**Note:**

- In order to that the motor identification routine supplies the correct data, before selecting, fast commissioning should be carried-out.
- If the motor data identification routine is activated (e.g. P1910 = 1), then at the next ON command, the measuring operation is started and alarm A0541 is generated. After the measurement is completed, both P1910 and the alarm are reset.

**Notice:**

When choosing the setting for measurement, observe the following:

1. "with parameter change"  
means that the value is actually adopted as P0350 parameter setting and applied to the control as well as being shown in the read-only parameters below.
2. "without parameter change"  
means that the value is only displayed, i.e. shown for checking purposes in the read-only parameter r1912 (identified stator resistance). The value is not applied to the control.

<b>r1912</b>	<b>Identified stator resistance</b>				Min: -	Level <b>2</b>
	Datatype: Float	Unit: Ohm	Def: -	Max: -		
	P-Group: MOTOR					

Displays measured stator resistance value (line-to-line) in [Ohms]

**Note:**

This value is measured using P1910 = 1 or 2 , i.e., identification of all parameters with/without change.

### 3.28 Reference parameters

<b>P2000</b>	<b>Reference frequency</b>	<b>Datatype:</b> Float	<b>Unit:</b> Hz	<b>Min:</b> 1.00	<b>Level</b> <b>2</b>
	<b>CStat:</b> CT	<b>Active:</b> first confirm	<b>QuickComm.:</b> No	<b>Def:</b> 50.00	
	<b>P-Group:</b> COMM			<b>Max:</b> 650.00	

Parameter P2000 represents the reference frequency for frequency values which are displayed/transferred as a percentage or a hexadecimal value. Where:

- hexadecimal 4000 H ==> P2000 (e.g.: USS-PZD)
- percentage 100 % ==> P2000 (e.g.: ADC)

**Example:**

If a BICO connection is made between two parameters or alternatively using P0719 or P1000, the "unit" of the parameters (standardized (Hex) or physical (i.e. Hz) values) may differ. MICROMASTER implicitly makes an automatic conversion to the target value.

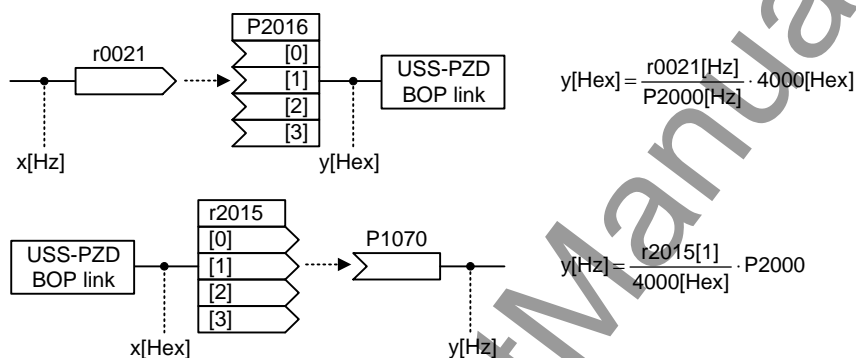

**Caution:**

Parameter P2000 represents the reference frequency of the above mentioned interfaces. A maximum frequency setpoint of 2\*P2000 can be applied via the corresponding interface. Unlike parameter P1082 (Max. Frequency) this limits the inverter frequency internally independent of the reference frequency. By modification of P2000 it will also adapt the parameter to the new settings.

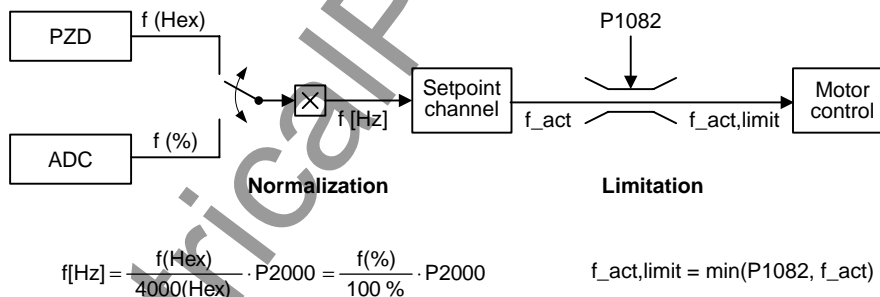

**Notice:**

Reference variables are intended as an aid to presenting setpoint and actual value signals in a uniform manner. This also applies to fixed settings entered as a percentage. A value of 100 % (USS / CB) corresponds to a process data value of 4000H, or 4000 0000H in the case of double values.

In this respect, the following parameters are available:

P2000	Reference frequency	Hz
P2001	Reference voltage	V
P2002	Reference current	A

<b>P2001</b>	<b>Reference voltage</b>	<b>Datatype:</b> U16	<b>Unit:</b> V	<b>Min:</b> 10	<b>Level</b> <b>3</b>
	<b>CStat:</b> CT	<b>Active:</b> first confirm	<b>QuickComm.:</b> No	<b>Def:</b> 1000	
	<b>P-Group:</b> COMM			<b>Max:</b> 2000	

Full-scale output voltage (i.e. 100 %) used over serial link (corresponds to 4000H).

**Example:**

P2001 = 230 specifies that 4000H received via USS denotes 230 V.

If a BICO connection is made between two parameters, the "unit" of the parameters (standardized (Hex) or physical (i.e. V) values) may differ. MICROMASTER implicitly makes an automatic conversion to the target value.

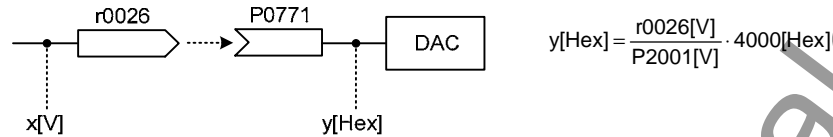

<b>P2002</b>	<b>Reference current</b>	<b>Datatype:</b> Float	<b>Unit:</b> A	<b>Min:</b> 0.10	<b>Level</b> <b>3</b>
	<b>CStat:</b> CT	<b>Active:</b> first confirm	<b>QuickComm.:</b> No	<b>Def:</b> 0.10	
	<b>P-Group:</b> COMM			<b>Max:</b> 10000.00	

Full-scale output current used over serial link (corresponds to 4000H).

**Example:**

If a BICO connection is made between two parameters, the "unit" of the parameters (standardized (Hex) or physical (i.e. A) values) may differ. MICROMASTER implicitly makes an automatic conversion to the target value.

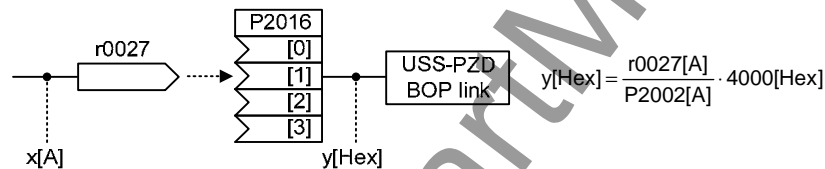

### 3.29 Communication parameters (USS, CB)

<b>P2009[2]</b>	<b>USS denormalization</b>			<b>Min:</b> 0	<b>Level</b> <b>3</b>
	<b>CStat:</b> CT	<b>Datatype:</b> U16	<b>Unit:</b> -	<b>Def:</b> 0	
	<b>P-Group:</b> COMM	<b>Active:</b> first confirm	<b>QuickComm.:</b> No	<b>Max:</b> 1	

Enables denormalization for USS.

**Possible Settings:**

0 Disabled  
1 Enabled

**Index:**

P2009[0] : Serial interface COM link  
P2009[1] : Serial interface BOP link

**Note:**

If denormalization is enabled, the main setpoint (word 2 in PZD) is not interpreted as 100 % = 4000H, but as "absolute" instead (e.g. 4000H = 16384 means 163.84 Hz) if this is a frequency. Denormalization (P2009 = 1) only works for frequencies and is intended for backwards compatibility with MM3.

<b>P2010[2]</b>	<b>USS baudrate</b>			<b>Min:</b> 3	<b>Level</b> <b>2</b>
	<b>CStat:</b> CUT	<b>Datatype:</b> U16	<b>Unit:</b> -	<b>Def:</b> 6	
	<b>P-Group:</b> COMM	<b>Active:</b> first confirm	<b>QuickComm.:</b> No	<b>Max:</b> 9	

Sets baud rate for USS communication.

**Possible Settings:**

3 1200 baud  
4 2400 baud  
5 4800 baud  
6 9600 baud  
7 19200 baud  
8 38400 baud  
9 57600 baud

**Index:**

P2010[0] : Serial interface COM link  
P2010[1] : Serial interface BOP link

<b>P2011[2]</b>	<b>USS address</b>			<b>Min:</b> 0	<b>Level</b> <b>2</b>
	<b>CStat:</b> CUT	<b>Datatype:</b> U16	<b>Unit:</b> -	<b>Def:</b> 0	
	<b>P-Group:</b> COMM	<b>Active:</b> first confirm	<b>QuickComm.:</b> No	<b>Max:</b> 31	

Sets unique address for inverter.

**Index:**

P2011[0] : Serial interface COM link  
P2011[1] : Serial interface BOP link

**Note:**

You can connect up to a further 30 inverters via the serial link (i.e. 31 inverters in total) and control them with the USS serial bus protocol.

<b>P2012[2]</b>	<b>USS PZD length</b>	<b>Datatype:</b> U16	<b>Unit:</b> -	<b>Min:</b> 0	<b>Level</b> <b>3</b>
	<b>CStat:</b> CUT	<b>Active:</b> first confirm	<b>QuickComm.:</b> No	<b>Def:</b> 2	
	<b>P-Group:</b> COMM			<b>Max:</b> 4	

Defines the number of 16-bit words in PZD part of USS telegram.

**Index:**

P2012[0] : Serial interface COM link  
 P2012[1] : Serial interface BOP link

**Notice:**

USS protocol consists of PZD and PKW which can be changed by the user via parameters P2012 and P2013 respectively.

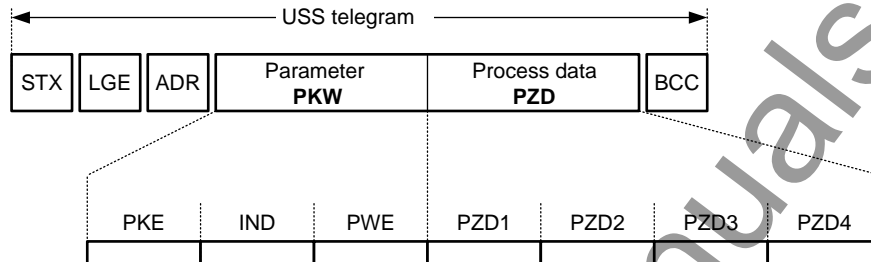

STX	Start of text	PKE	Parameter ID
LGE	Length	IND	Sub-index
ADR	Address	PWE	Parameter value
PKW	Parameter ID value		
PZD	Process data		
BCC	Block check character		

PZD transmits a control word and setpoint or status word and actual values. The number of PZD-words in a USS-telegram are determined by parameter P2012, where the first two words (P2012 >= 2) are either:

- control word and main setpoint or
- status word and actual value.

**Restrictions:**

- If the above serial interface controls the inverter (P0700 or P0719) then the 1st control word must be transferred in the 1st PZD-word.
- If the setpoint source is selected via P1000 or P0719, then the main setpoint must be transferred in the 2nd PZD-word.
- When P2012 is greater than or equal to 4 the additional control word (2nd control word) must be transferred in the 4th PZD-word, if the serial interface controls the inverter (P0700 or P0719).

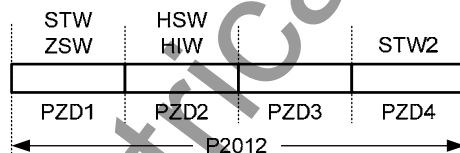

STW	Control word	HSW	Main setpoint
ZSW	Status word	HIW	Main actual value
PZD	Process data		

<b>P2013[2]</b>	<b>USS PKW length</b>			<b>Min:</b> 0	<b>Level 3</b>
	<b>CStat:</b> CUT	<b>Datatype:</b> U16	<b>Unit:</b> -	<b>Def:</b> 127	
	<b>P-Group:</b> COMM	<b>Active:</b> first confirm	<b>QuickComm.:</b> No	<b>Max:</b> 127	

Defines the number of 16-bit words in PKW part of USS telegram.

The PKW part consists of the PKE part (1. word), IND part (2. word) resp. PWE part (3. - n. word). In contrary to the IND and PKE part, the PWE part can be varied. Depending on the particular requirement, 3-word, 4-word or variable word lengths can be parameterized. The PKW part of the USS telegram is used to read and write individual parameter values.

**Possible Settings:**

- 0 No words
- 3 3 words
- 4 4 words
- 127 Variable

**Index:**

- P2013[0] : Serial interface COM link
- P2013[1] : Serial interface BOP link

**Example:**

	Data type		
	U16 (16 Bit)	U32 (32 Bit)	Float (32 Bit)
P2013 = 3	X	Parameter access fault	Parameter access fault
P2013 = 4	X	X	X
P2013 = 127	X	X	X

**Notice:**

USS protocol consists of PZD and PKW which can be changed by the user via parameters P2012 and P2013 respectively. Parameter P2013 determines the number of PKW-words in a USS-telegram.

Setting P2013 to 3 or 4 determines the length of the PKW (3 = three words and 4 = four words). When P2013 set to 127 automatically adjusts the length of the PKW words are required.

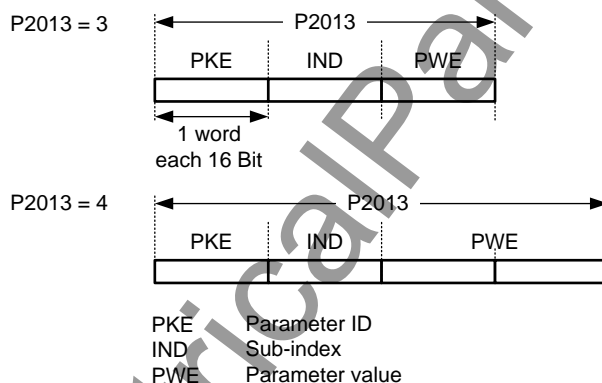

If a fixed PKW length is selected only one parameter value can be transferred. In the case of indexed parameter, you must use the variable PKW length if you wish to have the values of all indices transferred in a single telegram. In selecting the fixed PKW length, it is important to ensure the value in question can be transferred using this PKW length.

P2013 = 3, fixes PKW length, but does not allow access to many parameter values. A parameter fault is generated when an out-of-range value is used, the value will not be accepted but the inverter state will not be affected. Useful for applications where parameters are not changed, but MM3s are also used. Broadcast mode is not possible with this setting.

P2013 = 4, fixes PKW length. Allows access to all parameters, but indexed parameters can only be read one index at a time. Word order for single word values are different to setting 3 or 127, see example below.

P2013 = 127, most useful setting. PKW reply length varies depending on the amount of information needed. Can read fault information and all indices of a parameter with a single telegram with this setting.

**Example:**

Set P0700 to value 5 (0700 = 2BC (hex))

	P2013 = 3	P2013 = 4	P2013 = 127
Master → MM4	22BC 0000 0005	22BC 0000 0000 0005	22BC 0000 0005 0000
MM4 → Master	12BC 0000 0005	12BC 0000 0000 0005	12BC 0000 0005

<b>P2014[2]</b>	<b>USS telegram off time</b>	<b>Min:</b> 0	<b>Level</b>
	<b>CStat:</b> CT	<b>Datatype:</b> U16	<b>Unit:</b> ms
	<b>P-Group:</b> COMM	<b>Active:</b> Immediately	<b>QuickComm.:</b> No
		<b>Def:</b> 0	<b>3</b>
		<b>Max:</b> 65535	

Defines the telegram failure time for the serial interfaces with USS protocol.

The telegram failure time defines the time within which a valid telegram must have been received. If a valid telegram is not received within the specified time, the drive inverter outputs fault F0070.

**Index:**

- P2014[0] : Serial interface COM link
- P2014[1] : Serial interface BOP link

**Notice:**

By default (time set to 0), no fault is generated (i.e. watchdog disabled).

<b>r2015[4]</b>	<b>CO: PZD from BOP link (USS)</b>	<b>Min:</b> -	<b>Level</b>
	<b>P-Group:</b> COMM	<b>Datatype:</b> U16	<b>Unit:</b> -
			<b>Def:</b> -
		<b>Max:</b> -	<b>3</b>

Displays process data received via USS on BOP link (RS232 USS).

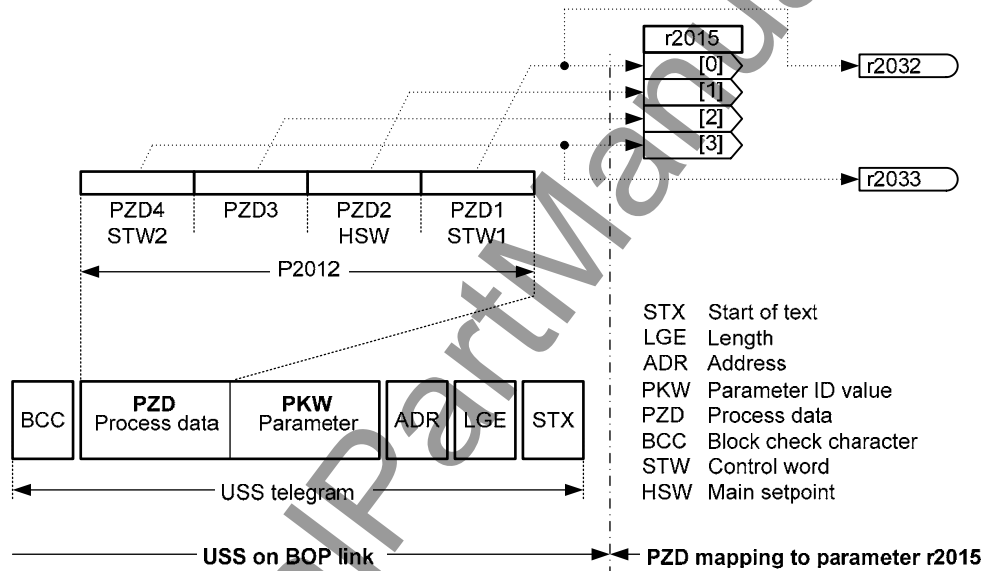

**Index:**

- r2015[0] : Received word 0
- r2015[1] : Received word 1
- r2015[2] : Received word 2
- r2015[3] : Received word 3

**Note:**

The control words can be viewed as bit parameters r2032 and r2033.

**Restrictions:**

- If the above serial interface controls the inverter (P0700 or P0719) then the 1st control word must be transferred in the 1st PZD-word.
- If the setpoint source is selected via P1000 or P0719, then the main setpoint must be transferred in the 2nd PZD-word,
- When P2012 is equal to 4 the additional control word (2nd control word) must transferred in the 4th PZD-word, if the above serial interface controls the inverter (P0700 or P0719).

<b>P2016[4]</b>	<b>CI: PZD to BOP link (USS)</b>				<b>Min:</b> 0:0	<b>Level</b> <b>3</b>
	<b>CStat:</b> CT	<b>Datatype:</b> U32	<b>Unit:</b> -	<b>Def:</b> 52:0		
	<b>P-Group:</b> COMM	<b>Active:</b> Immediately	<b>QuickComm.:</b> No	<b>Max:</b> 4000:0		

Selects signals (process data PZD) to be transmitted to serial interface via USS on BOP link

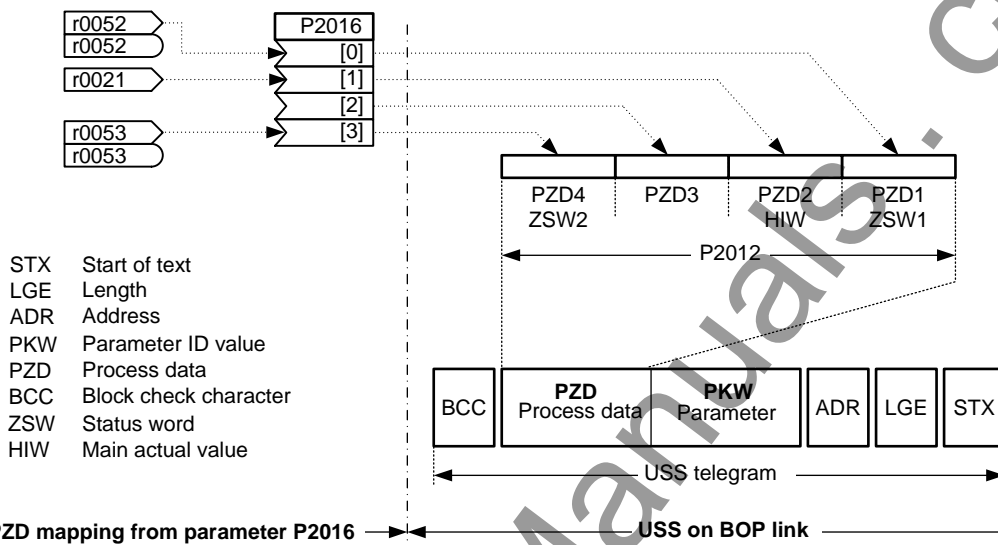

**Index:**

- P2016[0] : Transmitted word 0
- P2016[1] : Transmitted word 1
- P2016[2] : Transmitted word 2
- P2016[3] : Transmitted word 3

**Example:**

P2016[0] = 52.0 (default). In this case, the value of r0052[0] (CO/BO: Status word) is transmitted as 1st PZD to the BOP link.

**Note:**

If r0052 not indexed, display does not show an index (".0").

<b>r2018[4]</b>	<b>CO: PZD from COM link (USS)</b>	<b>Datatype: U16</b>	<b>Unit: -</b>	<b>Min: -</b>	<b>Def: -</b>	<b>Level</b>
	<b>P-Group: COMM</b>			<b>Max: -</b>		<b>3</b>

Displays process data received via USS on COM link.

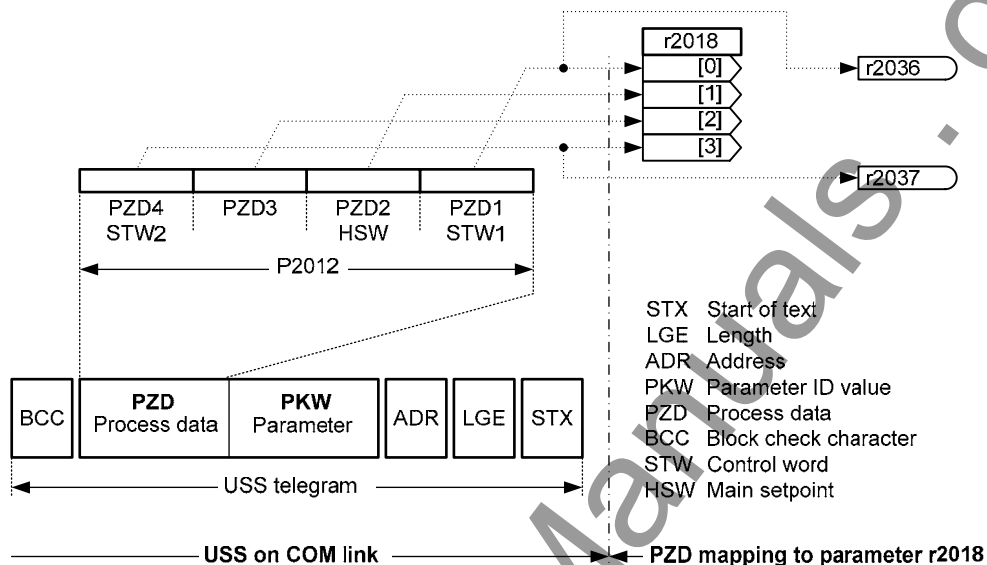

**Index:**

- r2018[0] : Received word 0
- r2018[1] : Received word 1
- r2018[2] : Received word 2
- r2018[3] : Received word 3

**Note:**

The control words can be viewed as bit parameters r2036 and r2037.

**Restrictions:**

- If the above serial interface controls the inverter (P0700 or P0719) then the 1st control word must be transferred in the 1st PZD-word.
- If the setpoint source is selected via P1000 or P0719, then the main setpoint must be transferred in the 2nd PZD-word,
- When P2012 is equal to 4 the additional control word (2nd control word) must transferred in the 4th PZD-word, if the above serial interface controls the inverter (P0700 or P0719).

<b>P2019[4]</b>	<b>CI: PZD to COM link (USS)</b>	<b>Min:</b> 0:0	<b>Level</b> <b>3</b>	
	<b>CStat:</b> CT	<b>Datatype:</b> U32		<b>Def:</b> 52:0
	<b>P-Group:</b> COMM	<b>Active:</b> Immediately		<b>QuickComm.:</b> No

Selects signals (process data PZD) to be transmitted to serial interface via USS on COM link

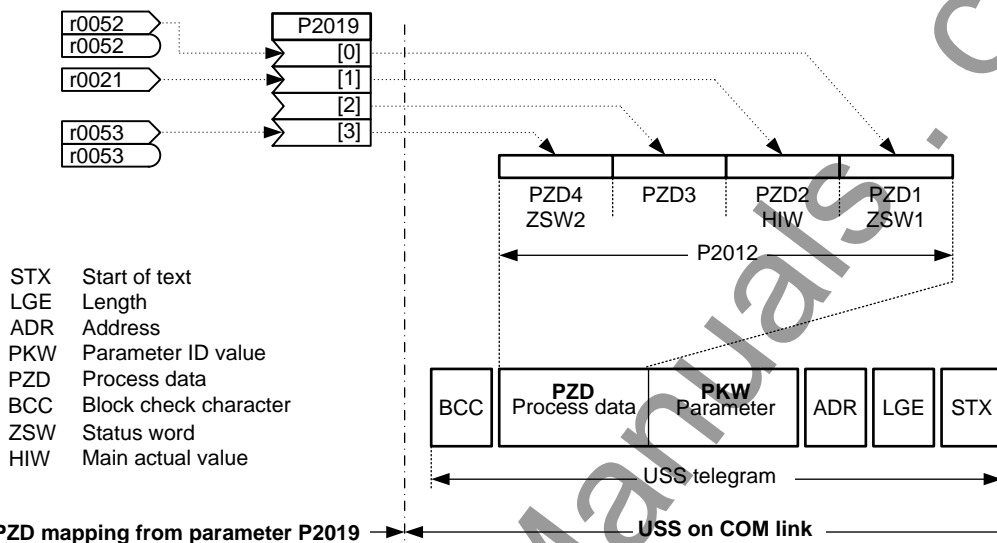

**Index:**

- P2019[0] : Transmitted word 0
- P2019[1] : Transmitted word 1
- P2019[2] : Transmitted word 2
- P2019[3] : Transmitted word 3

**Details:**

See P2016 (PZD to BOP link)

<b>r2024[2]</b>	<b>USS error-free telegrams</b>	<b>Min:</b> -	<b>Level</b> <b>3</b>
	<b>Datatype:</b> U16	<b>Def:</b> -	
	<b>P-Group:</b> COMM	<b>Max:</b> -	

Displays number of error-free USS telegrams received.

**Index:**

- r2024[0] : Serial interface COM link
- r2024[1] : Serial interface BOP link

<b>r2025[2]</b>	<b>USS rejected telegrams</b>	<b>Min:</b> -	<b>Level</b> <b>3</b>
	<b>Datatype:</b> U16	<b>Def:</b> -	
	<b>P-Group:</b> COMM	<b>Max:</b> -	

Displays the number of rejected USS telegrams. The sum of all USS errors (r2026 - r2031) is displayed in parameter r2025.

The following monitoring mechanisms have been implemented

- when a telegram is received, then initially, the correct start of a telegram (start interval + STX) must be identified and then the length must be evaluated (LGE). If the length does not correspond to the selected value for a fixed telegram or it does not have a valid value for a variable telegram length, the telegram is rejected.
- the appropriate times are monitored before and while receiving telegrams.
- the block check character (BCC) is generated while the telegram is received and after the complete telegram has been read-in, this is compared with the received BCC. If these do not match, then the telegram is not evaluated.
- if a character frame error or a parity error has not occurred in any of the received characters, then the node number (ADR) of the received telegram can be evaluated.
- the telegram is rejected if the address byte (ADR) does not correspond to the node number (for slave) or the expected slave node number (for the master).

**Index:**

- r2025[0] : Serial interface COM link
- r2025[1] : Serial interface BOP link

<b>r2026[2]</b>	<b>USS character frame error</b>	<b>Min:</b> -	<b>Level</b> <b>3</b>
	<b>Datatype:</b> U16	<b>Def:</b> -	
	<b>P-Group:</b> COMM	<b>Max:</b> -	

Displays number of USS character frame errors.

**Index:**

- r2026[0] : Serial interface COM link
- r2026[1] : Serial interface BOP link

<b>r2027[2]</b>	<b>USS overrun error</b>	<b>Datatype:</b> U16	<b>Unit:</b> -	<b>Min:</b> - <b>Def:</b> - <b>Max:</b> -	Level <b>3</b>
	<b>P-Group:</b> COMM				
Displays number of USS telegrams with overrun error.					
<b>Index:</b> r2027[0] : Serial interface COM link r2027[1] : Serial interface BOP link					
<b>r2028[2]</b>	<b>USS parity error</b>	<b>Datatype:</b> U16	<b>Unit:</b> -	<b>Min:</b> - <b>Def:</b> - <b>Max:</b> -	Level <b>3</b>
	<b>P-Group:</b> COMM				
Displays number of USS telegrams with parity error.					
<b>Index:</b> r2028[0] : Serial interface COM link r2028[1] : Serial interface BOP link					
<b>r2029[2]</b>	<b>USS start not identified</b>	<b>Datatype:</b> U16	<b>Unit:</b> -	<b>Min:</b> - <b>Def:</b> - <b>Max:</b> -	Level <b>3</b>
	<b>P-Group:</b> COMM				
Displays number of USS telegrams with unidentified start.					
<b>Index:</b> r2029[0] : Serial interface COM link r2029[1] : Serial interface BOP link					
<b>r2030[2]</b>	<b>USS BCC error</b>	<b>Datatype:</b> U16	<b>Unit:</b> -	<b>Min:</b> - <b>Def:</b> - <b>Max:</b> -	Level <b>3</b>
	<b>P-Group:</b> COMM				
Displays number of USS telegrams with BCC error.					
<b>Index:</b> r2030[0] : Serial interface COM link r2030[1] : Serial interface BOP link					
<b>r2031[2]</b>	<b>USS length error</b>	<b>Datatype:</b> U16	<b>Unit:</b> -	<b>Min:</b> - <b>Def:</b> - <b>Max:</b> -	Level <b>3</b>
	<b>P-Group:</b> COMM				
Displays number of USS telegrams with incorrect length.					
<b>Index:</b> r2031[0] : Serial interface COM link r2031[1] : Serial interface BOP link					
<b>r2032</b>	<b>BO: CtrlWrd1 from BOP link (USS)</b>	<b>Datatype:</b> U16	<b>Unit:</b> -	<b>Min:</b> - <b>Def:</b> - <b>Max:</b> -	Level <b>3</b>
	<b>P-Group:</b> COMM				
Displays control word 1 from BOP link (word 1 within USS).					
<b>Bitfields:</b>					
Bit00	ON/OFF1	0	NO	1	YES
Bit01	OFF2: Electrical stop	0	YES	1	NO
Bit02	OFF3: Fast stop	0	YES	1	NO
Bit03	Pulses enabled	0	NO	1	YES
Bit04	RFG enable	0	NO	1	YES
Bit05	RFG start	0	NO	1	YES
Bit06	Setpoint enable	0	NO	1	YES
Bit07	Fault acknowledge	0	NO	1	YES
Bit08	JOG right	0	NO	1	YES
Bit09	JOG left	0	NO	1	YES
Bit10	Control from PLC	0	NO	1	YES
Bit11	Reverse (setpoint inversion)	0	NO	1	YES
Bit13	Motor potentiometer MOP up	0	NO	1	YES
Bit14	Motor potentiometer MOP down	0	NO	1	YES
Bit15	Local / Remote	0	NO	1	YES

<b>r2033</b>	<b>BO: CtrlWrd2 from BOP link (USS)</b>	<b>Datatype:</b> U16	<b>Unit:</b> -	<b>Min:</b> -	<b>Def:</b> -	<b>Max:</b> -	Level <b>3</b>
	<b>P-Group:</b> COMM						

Displays control word 2 from BOP link (i.e. word 4 within USS).

**Bitfields:**

Bit00	Fixed frequency Bit 0	0	NO	1	YES
Bit01	Fixed frequency Bit 1	0	NO	1	YES
Bit02	Fixed frequency Bit 2	0	NO	1	YES
Bit08	PID enabled	0	NO	1	YES
Bit09	DC brake enabled	0	NO	1	YES
Bit13	External fault 1	0	YES	1	NO

**Dependency:**

P0700 = 4 (USS on BOP link) and P0719 = 0 (Cmd / Setpoint = BICO parameter).

<b>r2036</b>	<b>BO: CtrlWrd1 from COM link (USS)</b>	<b>Datatype:</b> U16	<b>Unit:</b> -	<b>Min:</b> -	<b>Def:</b> -	<b>Max:</b> -	Level <b>3</b>
	<b>P-Group:</b> COMM						

Displays control word 1 from COM link (i.e. word 1 within USS).

**Bitfields:**

Bit00	ON/OFF1	0	NO	1	YES
Bit01	OFF2: Electrical stop	0	YES	1	NO
Bit02	OFF3: Fast stop	0	YES	1	NO
Bit03	Pulses enabled	0	NO	1	YES
Bit04	RFG enable	0	NO	1	YES
Bit05	RFG start	0	NO	1	YES
Bit06	Setpoint enable	0	NO	1	YES
Bit07	Fault acknowledge	0	NO	1	YES
Bit08	JOG right	0	NO	1	YES
Bit09	JOG left	0	NO	1	YES
Bit10	Control from PLC	0	NO	1	YES
Bit11	Reverse (setpoint inversion)	0	NO	1	YES
Bit13	Motor potentiometer MOP up	0	NO	1	YES
Bit14	Motor potentiometer MOP down	0	NO	1	YES
Bit15	Local / Remote	0	NO	1	YES

**Details:**

See r2033 (control word 2 from BOP link).

<b>r2037</b>	<b>BO: CtrlWrd2 from COM link (USS)</b>	<b>Datatype:</b> U16	<b>Unit:</b> -	<b>Min:</b> -	<b>Def:</b> -	<b>Max:</b> -	Level <b>3</b>
	<b>P-Group:</b> COMM						

Displays control word 2 from COM link (i.e. word 4 within USS).

**Bitfields:**

Bit00	Fixed frequency Bit 0	0	NO	1	YES
Bit01	Fixed frequency Bit 1	0	NO	1	YES
Bit02	Fixed frequency Bit 2	0	NO	1	YES
Bit08	PID enabled	0	NO	1	YES
Bit09	DC brake enabled	0	NO	1	YES
Bit13	External fault 1	0	YES	1	NO

**Details:**

See r2033 (control word 2 from BOP link).

<b>P2040</b>	<b>CB telegram off time</b>	<b>Datatype:</b> U16	<b>Unit:</b> ms	<b>Min:</b> 0	<b>Def:</b> 20	<b>Max:</b> 65535	Level <b>3</b>
	<b>CStat:</b> CT	<b>Active:</b> Immediately	<b>QuickComm.:</b> No				

Defines time after which a fault will be generated (F0070) if no telegram is received via the link.

The telegram off time defines the time, within which a valid telegram must be received. If no valid telegram is received within that time, the inverter trips with F0070.

**Dependency:**

Setting 0 = watchdog disabled

<b>P2041[5]</b>	<b>CB parameter</b>			<b>Min:</b> 0	<b>Level</b> <b>3</b>
	<b>CStat:</b> CT	<b>Datatype:</b> U16	<b>Unit:</b> -	<b>Def:</b> 0	
	<b>P-Group:</b> COMM	<b>Active:</b> first confirm	<b>QuickComm.:</b> No	<b>Max:</b> 65535	

Configures a communication board (CB).

**Index:**

- P2041[0] : CB parameter 0
- P2041[1] : CB parameter 1
- P2041[2] : CB parameter 2
- P2041[3] : CB parameter 3
- P2041[4] : CB parameter 4

**Details:**

See relevant communication board manual for protocol definition and appropriate settings.

<b>r2050[4]</b>	<b>CO: PZD from CB</b>			<b>Min:</b> -	<b>Level</b> <b>3</b>
		<b>Datatype:</b> U16	<b>Unit:</b> -	<b>Def:</b> -	
	<b>P-Group:</b> COMM			<b>Max:</b> -	

Displays PZD received from communication board (CB).

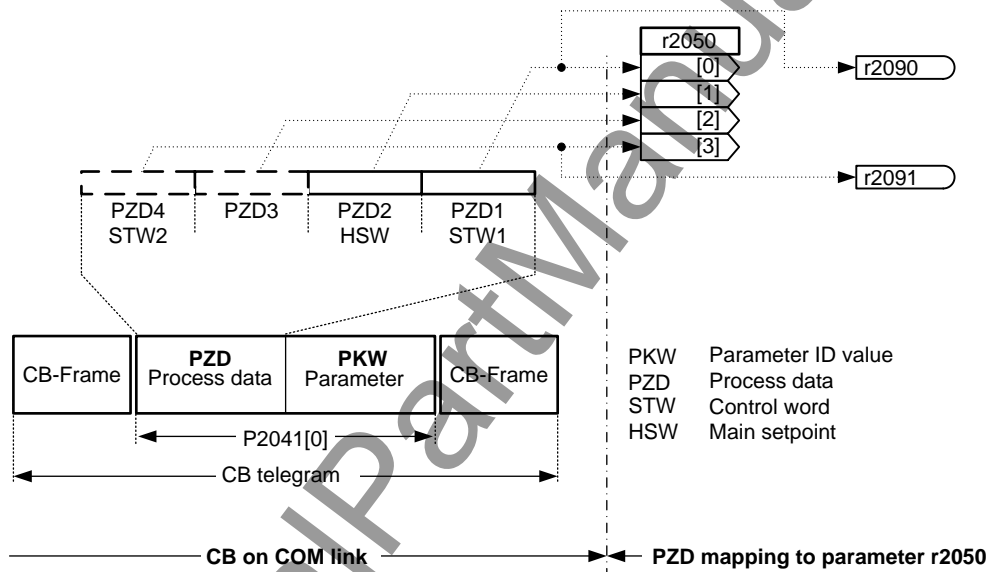

**Index:**

- r2050[0] : Received word 0
- r2050[1] : Received word 1
- r2050[2] : Received word 2
- r2050[3] : Received word 3

**Note:**

The control words can be viewed as bit parameters r2090 and r2091.

**Restrictions:**

- If the above serial interface controls the inverter (P0700 or P0719) then the 1st control word must be transferred in the 1st PZD-word.
- If the setpoint source is selected via P1000 or P0719, then the main setpoint must be transferred in the 2nd PZD-word,
- When P2012 is equal to 4 the additional control word (2nd control word) must transferred in the 4th PZD-word, if the above serial interface controls the inverter (P0700 or P0719).

<b>P2051[4]</b>	<b>CI: PZD to CB</b>	<b>Datatype:</b> U32	<b>Unit:</b> -	<b>Min:</b> 0:0	<b>Level</b> <b>3</b>
	<b>CStat:</b> CT	<b>Active:</b> Immediately	<b>QuickComm.:</b> No	<b>Def:</b> 52:0	
	<b>P-Group:</b> COMM			<b>Max:</b> 4000:0	

Selects signals (process data PZD) to be transmitted via CB on COM link

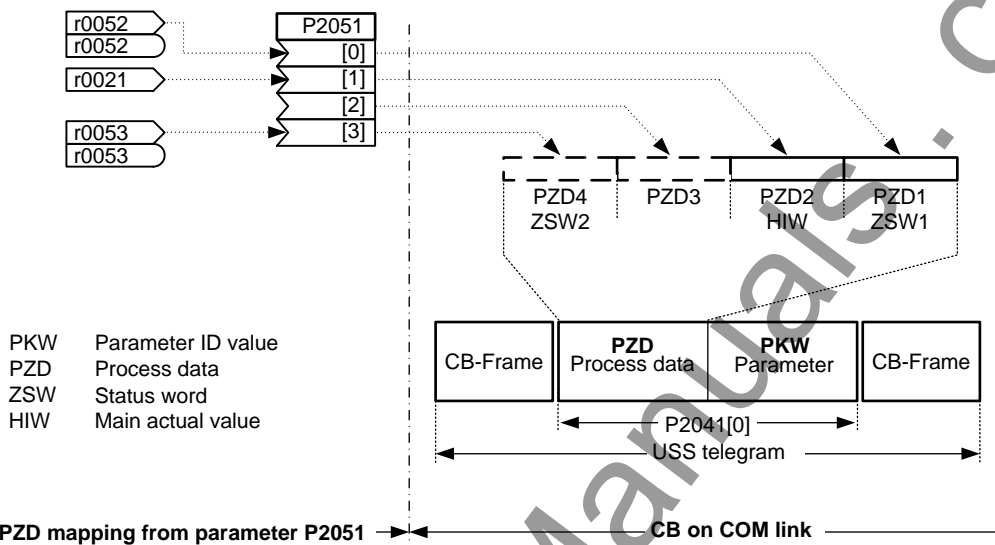

**Index:**

- P2051[0] : Transmitted word 0
- P2051[1] : Transmitted word 1
- P2051[2] : Transmitted word 2
- P2051[3] : Transmitted word 3

**Common Settings:**

- Status word 1 = 52 CO/BO: Act. status word 1 (see r0052)
- Actual value 1 = 21 inverter output frequency (see r0021)
- Other BICO settings are possible

<b>r2053[5]</b>	<b>CB identification</b>	<b>Datatype:</b> U16	<b>Unit:</b> -	<b>Min:</b> -	<b>Level</b> <b>3</b>
	<b>P-Group:</b> COMM			<b>Def:</b> -	
				<b>Max:</b> -	

Displays identification data of the communication board (CB). The different CB types (r2053[0]) are given in the Enum declaration.

**Possible Settings:**

- 0 No CB option board
- 1 PROFIBUS DP
- 2 DeviceNet
- 256 not defined

**Index:**

- r2053[0] : CB type (PROFIBUS = 1)
- r2053[1] : Firmware version
- r2053[2] : Firmware version detail
- r2053[3] : Firmware date (year)
- r2053[4] : Firmware date (day/month)

<b>r2054[7]</b>	<b>CB diagnosis</b>	<b>Datatype:</b> U16	<b>Unit:</b> -	<b>Min:</b> -	<b>Level</b> <b>3</b>
	<b>P-Group:</b> COMM			<b>Def:</b> -	
				<b>Max:</b> -	

Displays diagnostic information of communication board (CB).

**Index:**

- r2054[0] : CB diagnosis 0
- r2054[1] : CB diagnosis 1
- r2054[2] : CB diagnosis 2
- r2054[3] : CB diagnosis 3
- r2054[4] : CB diagnosis 4
- r2054[5] : CB diagnosis 5
- r2054[6] : CB diagnosis 6

**Details:**

See relevant communications board manual.

<b>r2090</b>	<b>BO: Control word 1 from CB</b>	<b>Datatype:</b> U16	<b>Unit:</b> -	<b>Min:</b> -	Level <b>3</b>
	<b>P-Group:</b> COMM			<b>Def:</b> - <b>Max:</b> -	

Displays control word 1 received from communication board (CB).

**Bitfields:**

Bit00	ON/OFF1	0	NO	1	YES
Bit01	OFF2: Electrical stop	0	YES	1	NO
Bit02	OFF3: Fast stop	0	YES	1	NO
Bit03	Pulses enabled	0	NO	1	YES
Bit04	RFG enable	0	NO	1	YES
Bit05	RFG start	0	NO	1	YES
Bit06	Setpoint enable	0	NO	1	YES
Bit07	Fault acknowledge	0	NO	1	YES
Bit08	JOG right	0	NO	1	YES
Bit09	JOG left	0	NO	1	YES
Bit10	Control from PLC	0	NO	1	YES
Bit11	Reverse (setpoint inversion)	0	NO	1	YES
Bit13	Motor potentiometer MOP up	0	NO	1	YES
Bit14	Motor potentiometer MOP down	0	NO	1	YES
Bit15	Local / Remote	0	NO	1	YES

**Details:**

See relevant communication board manual for protocol definition and appropriate settings.

<b>r2091</b>	<b>BO: Control word 2 from CB</b>	<b>Datatype:</b> U16	<b>Unit:</b> -	<b>Min:</b> -	Level <b>3</b>
	<b>P-Group:</b> COMM			<b>Def:</b> - <b>Max:</b> -	

Displays control word 2 received from communication board (CB).

**Bitfields:**

Bit00	Fixed frequency Bit 0	0	NO	1	YES
Bit01	Fixed frequency Bit 1	0	NO	1	YES
Bit02	Fixed frequency Bit 2	0	NO	1	YES
Bit08	PID enabled	0	NO	1	YES
Bit09	DC brake enabled	0	NO	1	YES
Bit13	External fault 1	0	YES	1	NO

**Details:**

See relevant communication board manual for protocol definition and appropriate settings.

### 3.30 Faults, Alarms, Monitoring

<b>P2100[3]</b>	<b>Alarm number selection</b>	<b>Min:</b> 0	<b>Level</b> <b>3</b>	
	<b>CStat:</b> CT	<b>Datatype:</b> U16		<b>Unit:</b> -
	<b>P-Group:</b> ALARMS	<b>Active:</b> first confirm		<b>QuickComm.:</b> No

Selects up to 3 faults or warnings for non-default reactions.

**Index:**

P2100[0] : Fault Number 1  
P2100[1] : Fault Number 2  
P2100[2] : Fault Number 3

**Example:**

If you want F0005 to perform an OFF3 instead of an OFF2, set P2100[0] = 5, then select the desired reaction in P2101[0] (in this case, set P2101[0] = 3).

**Note:**

All fault codes have a default reaction to OFF2. Some fault codes caused by hardware trips (e.g. overcurrent) cannot be changed from the default reactions.

<b>P2101[3]</b>	<b>Stop reaction value</b>	<b>Min:</b> 0	<b>Level</b> <b>3</b>	
	<b>CStat:</b> CT	<b>Datatype:</b> U16		<b>Unit:</b> -
	<b>P-Group:</b> ALARMS	<b>Active:</b> first confirm		<b>QuickComm.:</b> No

Sets drive stop reaction values for fault selected by P2100 (alarm number stop reaction).

This indexed parameter specifies the special reaction to the faults/warnings defined in P2100 indices 0 to 2.

**Possible Settings:**

0 No reaction, no display  
1 OFF1 stop reaction  
2 OFF2 stop reaction  
3 OFF3 stop reaction  
4 No reaction warning only

**Index:**

P2101[0] : Stop reaction value 1  
P2101[1] : Stop reaction value 2  
P2101[2] : Stop reaction value 3

**Note:**

- Settings 0 - 3 only are available for fault codes.
- Settings 0 and 4 only are available for warnings.
- Index 0 (P2101) refers to fault/warning in index 0 (P2100).

<b>P2103</b>	<b>BI: 1. Faults acknowledgement</b>	<b>Min:</b> 0:0	<b>Level</b> <b>3</b>	
	<b>CStat:</b> CT	<b>Datatype:</b> U32		<b>Unit:</b> -
	<b>P-Group:</b> COMMANDS	<b>Active:</b> first confirm		<b>QuickComm.:</b> No

Defines first source of fault acknowledgement, e.g. keypad/DIN, etc. (depending on setting).

**Common Settings:**

722.0 = Digital input 1 (requires P0701 to be set to 99, BICO)  
722.1 = Digital input 2 (requires P0702 to be set to 99, BICO)  
722.2 = Digital input 3 (requires P0703 to be set to 99, BICO)  
722.3 = Digital input 4 (via analog input, requires P0704 to be set to 99)

<b>P2104</b>	<b>BI: 2. Faults acknowledgement</b>	<b>Min:</b> 0:0	<b>Level</b> <b>3</b>	
	<b>CStat:</b> CT	<b>Datatype:</b> U32		<b>Unit:</b> -
	<b>P-Group:</b> COMMANDS	<b>Active:</b> first confirm		<b>QuickComm.:</b> No

Selects second source of fault acknowledgement.

**Common Settings:**

722.0 = Digital input 1 (requires P0701 to be set to 99, BICO)  
722.1 = Digital input 2 (requires P0702 to be set to 99, BICO)  
722.2 = Digital input 3 (requires P0703 to be set to 99, BICO)  
722.3 = Digital input 4 (via analog input, requires P0704 to be set to 99)

<b>P2106</b>	<b>BI: External fault</b>	<b>Min:</b> 0:0	<b>Level</b> <b>3</b>	
	<b>CStat:</b> CT	<b>Datatype:</b> U32		<b>Unit:</b> -
	<b>P-Group:</b> COMMANDS	<b>Active:</b> first confirm		<b>QuickComm.:</b> No

Selects source of external faults.

**Common Settings:**

722.0 = Digital input 1 (requires P0701 to be set to 99, BICO)  
722.1 = Digital input 2 (requires P0702 to be set to 99, BICO)  
722.2 = Digital input 3 (requires P0703 to be set to 99, BICO)  
722.3 = Digital input 4 (via analog input, requires P0704 to be set to 99)

<b>r2110[4]</b>	<b>CO: Warning number</b>	<b>Datatype:</b> U16	<b>Unit:</b> -	<b>Min:</b> - <b>Def:</b> - <b>Max:</b> -	Level <b>2</b>
-----------------	---------------------------	----------------------	----------------	---	-------------------

**P-Group:** ALARMS

Displays warning information.

A maximum of 2 active warnings (indices 0 and 1) and 2 historical warnings (indices 2 and 3) may be viewed.

**Index:**

r2110[0] : Recent Warnings --, warning 1  
r2110[1] : Recent Warnings --, warning 2  
r2110[2] : Recent Warnings -1, warning 3  
r2110[3] : Recent Warnings -1, warning 4

**Note:**

- Indices 0 and 1 are not stored.
- The keypad will flash while a warning is active. The LEDs indicate the warning status in this case.
- If an AOP is in use, the display will show number and text of the active warning.

<b>P2111</b>	<b>Total number of warnings</b>	<b>Datatype:</b> U16	<b>Unit:</b> -	<b>Min:</b> 0 <b>Def:</b> 0 <b>Max:</b> 4	Level <b>3</b>
--------------	---------------------------------	----------------------	----------------	---	-------------------

**CStat:** CUT  
**P-Group:** ALARMS

**Active:** first confirm

**QuickComm.:** No

Displays number of warning (up to 4) since last reset. Set to 0 to reset the warning history.

<b>r2114[2]</b>	<b>Run time counter</b>	<b>Datatype:</b> U16	<b>Unit:</b> -	<b>Min:</b> - <b>Def:</b> - <b>Max:</b> -	Level <b>3</b>
-----------------	-------------------------	----------------------	----------------	---	-------------------

**P-Group:** ALARMS

Displays run time counter.

It is the total time the drive has been powered up. When power goes value is saved, then restored on powerup. The run time counter r2114 will be calculate as followed:

- Multiply the value in r2114[0], by 65536 and then add it to the value in r2114[1].
- The resultant answer will be in seconds.

When AOP is not connected, the time in this parameter is used by r0948 to indicate when a fault has occurred.

**Index:**

r2114[0] : System Time, Seconds, Upper Word  
r2114[1] : System Time, Seconds, Lower Word

**Example:**

If r2114[0] = 1 & r2114[1] = 20864  
We get  $1 * 65536 + 20864 = 86400$  seconds which equals 1 day.

<b>P2115[3]</b>	<b>AOP real time clock</b>				<b>Min:</b> 0	<b>Level</b> <b>3</b>
	<b>CStat:</b> CT	<b>Datatype:</b> U16	<b>Unit:</b> -	<b>Def:</b> 0		
	<b>P-Group:</b> ALARMS	<b>Active:</b> Immediately	<b>QuickComm.:</b> No	<b>Max:</b> 65535		

Displays AOP real time.

All of the frequency inverters have an internal time generator function which is used to time-stamp and log erroneous conditions. Therefore there is no battery-buffered real-time clock (RTC). The frequency inverters can support a software-controlled RTC where the RTC must be set from the AOP or via an interface. When using the AOP, this synchronization is automatic. When a serial interface is used, a task must be sent from the higher-level control to write into the parameter. If the AOP is withdrawn during operation, or if the bus is interrupted, then the real-time clock runs further using the runtime counter. The real-time clock is reset to zero only after power off.

The time is stored in a word array parameter P2115. This parameter number is common to all inverters. Inverters not supporting this feature would respond with parameter not recognised - a Master will ignore this. The time will be set by USS Protocol standard word array parameter write telegrams.

Within the AOP, while it is acting as a USS Master, at each tick of the heartbeat, the list of available USS Slaves will be flagged with a time update request. As the Master runs around the list of USS slaves on its next USS update cycle, if there are no higher priority tasks to perform, and the slave still has its time update flag set, then an array parameter write telegram will be issued, containing the current time. The request for that slave is cancelled if the slave responds correctly. The AOP will not need to read the time from the slave.

Time is maintained in a word array parameter and encoded as follows - the same format will be used in fault report logs.

Index	High Byte (MSB)	Low Byte (LSB)
0	Seconds (0 - 59)	Minutes (0 - 59)
1	Hours (0 - 23)	Days (1 - 31)
2	Month (1 - 12)	Years (00 - 250)

Time is measured from Jan 1st 2000. Values are in binary form.

**Index:**

P2115[0] : Real Time, Seconds+Minutes  
P2115[1] : Real Time, Hours+Days  
P2115[2] : Real Time, Month+Year

**Example:**

P2115[0] = 13625  
P2115[1] = 2579  
P2115[2] = 516

The conversion into binary quantities (U16) results in the following bit pattern:

Seconds + minutes:

- High byte (MSB) = 00110101 corresponding to the number 53, i.e. seconds 53
- Low byte (LSB) = 00111001 corresponding to the number 57, i.e. minutes 57

Hours + days:

- High byte (MSB) = 00001010 corresponding to the number 10, i.e. hours 10
- Low byte (LSB) = 00010011 corresponding to the number 19, i.e. days 19

Months + year:

- High byte (MSB) = 00000010 corresponding to the number 2, i.e. months 2
- Low byte (LSB) = 00000100 corresponding to the number 4, i.e. years 4

This means that the real time displayed in P2115 is 19.02.2004, 10:57:53.

<b>P2120</b>	<b>Indication counter</b>				<b>Min:</b> 0	<b>Level</b> <b>4</b>
	<b>CStat:</b> CUT	<b>Datatype:</b> U16	<b>Unit:</b> -	<b>Def:</b> 0		
	<b>P-Group:</b> ALARMS	<b>Active:</b> Immediately	<b>QuickComm.:</b> No	<b>Max:</b> 65535		

Indicates total number of alarm events. This parameter is incremented whenever an alarm event occurs. It also gets incremented when a warning is cleared or faults are cleared.

This parameter is used by the PC tools.

<b>P2150</b>	<b>Hysteresis frequency f_hys</b>	<b>Min:</b> 0.00	<b>Level</b>
	<b>CStat:</b> CUT	<b>Datatype:</b> Float	<b>Unit:</b> Hz
	<b>P-Group:</b> ALARMS	<b>Active:</b> Immediately	<b>QuickComm.:</b> No
		<b>Def:</b> 3.00	<b>3</b>
		<b>Max:</b> 10.00	

Defines hysteresis level applied for comparing frequency and speed to threshold as illustrated in the diagram below.

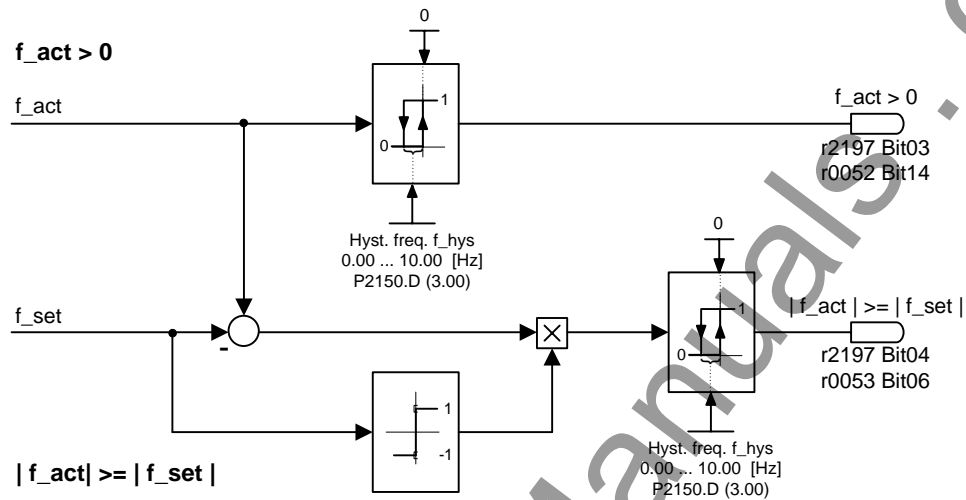

<b>P2155</b>	<b>Threshold frequency f_1</b>	<b>Min:</b> 0.00	<b>Level</b>
	<b>CStat:</b> CUT	<b>Datatype:</b> Float	<b>Unit:</b> Hz
	<b>P-Group:</b> ALARMS	<b>Active:</b> Immediately	<b>QuickComm.:</b> No
		<b>Def:</b> 30.00	<b>3</b>
		<b>Max:</b> 650.00	

Sets a threshold for comparing actual frequency or frequency to threshold values f\_1. This threshold controls status bits 4 and 5 in status word 2 (r0053).

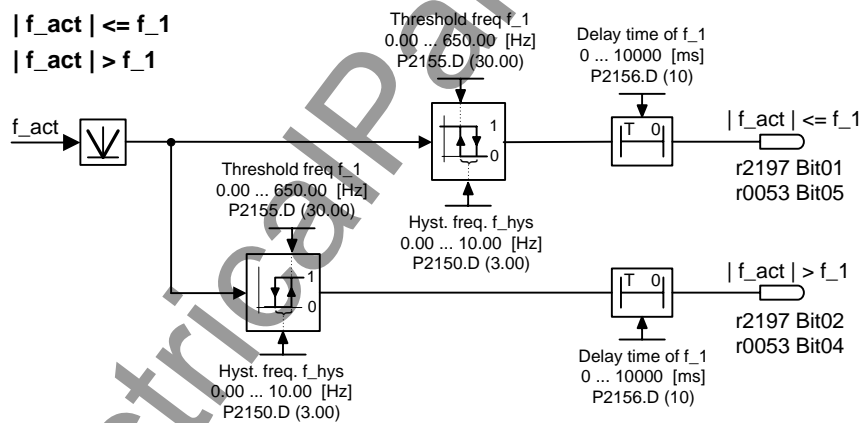

<b>P2156</b>	<b>Delay time of threshold freq f_1</b>	<b>Min:</b> 0	<b>Level</b>
	<b>CStat:</b> CUT	<b>Datatype:</b> U16	<b>Unit:</b> ms
	<b>P-Group:</b> ALARMS	<b>Active:</b> Immediately	<b>QuickComm.:</b> No
		<b>Def:</b> 10	<b>3</b>
		<b>Max:</b> 10000	

Sets delay time prior to threshold frequency f\_1 comparison (P2155).

**Details:**  
See diagram in P2155 (threshold frequency f\_1)

<b>P2164</b>	<b>Hysteresis frequency deviation</b>	<b>Min:</b> 0.00	<b>Level</b>
	<b>CStat:</b> CUT	<b>Datatype:</b> Float	<b>Unit:</b> Hz
	<b>P-Group:</b> ALARMS	<b>Active:</b> Immediately	<b>QuickComm.:</b> No
		<b>Def:</b> 3.00	<b>3</b>
		<b>Max:</b> 10.00	

Hysteresis frequency for detecting permitted deviation (from setpoint). This frequency controls bit 8 in status word 1 (r0052) and bit 6 in status word 2 (r0053).

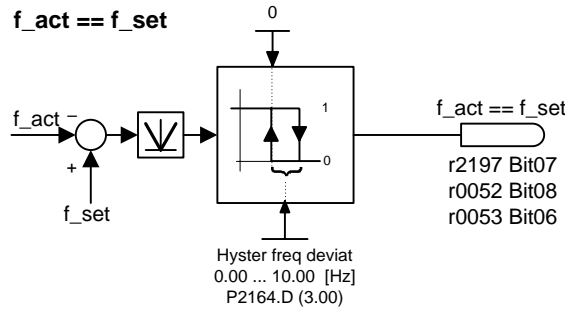

<b>P2167</b>	<b>Switch-off frequency f_off</b>	<b>Min:</b> 0.00	<b>Level</b>
	<b>CStat:</b> CUT	<b>Datatype:</b> Float	<b>Unit:</b> Hz
	<b>P-Group:</b> ALARMS	<b>Active:</b> Immediately	<b>QuickComm.:</b> No
		<b>Def:</b> 1.00	<b>3</b>
		<b>Max:</b> 10.00	

Defines the threshold of the monitoring function  $|f_{act}| \leq P2167 (f_{off})$ .

P2167 influences following functions:

- If the actual frequency falls below this threshold and the time delay has expired, bit 1 in status word 2 (r0053) is reset.
- If a OFF1 or OFF3 was applied and bit 1 is reset the inverter will disable the pulse (OFF2).

Restriction:

- The monitoring function  $|f_{act}| \leq P2167 (f_{off})$  is not updated and pulses are not disabled, if motor holding brake (MHB, P1215 = 1) is enabled.

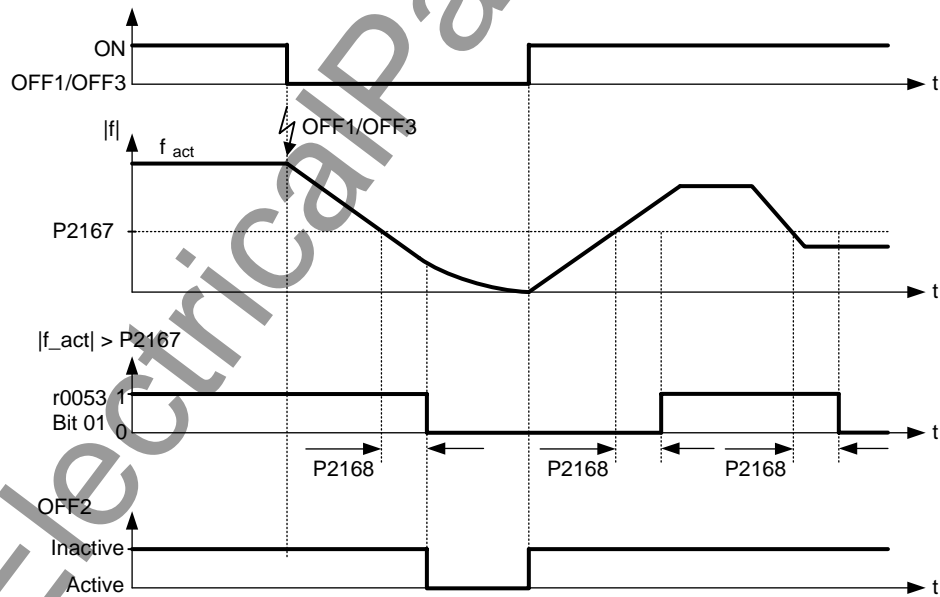

<b>P2168</b>	<b>Delay time T_off</b>	<b>Min:</b> 0	<b>Level</b>
	<b>CStat:</b> CUT	<b>Datatype:</b> U16	<b>Unit:</b> ms
	<b>P-Group:</b> ALARMS	<b>Active:</b> Immediately	<b>QuickComm.:</b> No
		<b>Def:</b> 10	<b>3</b>
		<b>Max:</b> 10000	

Defines time for which the inverter may operate below switch-off frequency (P2167) before switch off occurs.

**Dependency:**

Active if holding brake (P1215) not parameterized.

**Details:**

See diagram in P2167 (switch-off frequency)

<b>P2170</b>	<b>Threshold current I_thresh</b>	<b>Min:</b> 0.0	<b>Level</b>
	<b>CStat:</b> CUT	<b>Datatype:</b> Float	<b>Unit:</b> %
	<b>P-Group:</b> ALARMS	<b>Active:</b> Immediately	<b>QuickComm.:</b> No
		<b>Def:</b> 100.0	<b>3</b>
		<b>Max:</b> 400.0	

Defines threshold current in [%] relative to P0305 (rated motor current) to be used in comparisons of I\_act and I\_Thresh as illustrated in the diagram below.

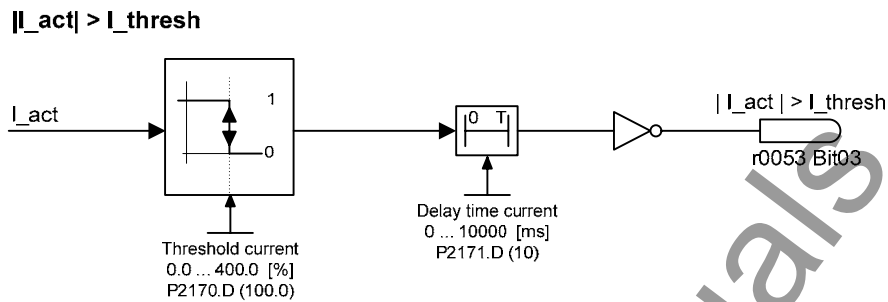

**Note:** This threshold controls bit 3 in status word 3 (r0053).

<b>P2171</b>	<b>Delay time current</b>	<b>Min:</b> 0	<b>Level</b>
	<b>CStat:</b> CUT	<b>Datatype:</b> U16	<b>Unit:</b> ms
	<b>P-Group:</b> ALARMS	<b>Active:</b> Immediately	<b>QuickComm.:</b> No
		<b>Def:</b> 10	<b>3</b>
		<b>Max:</b> 10000	

Defines delay time prior to activation of current comparison.

**Details:** See diagram in P2170 (threshold current I\_thresh)

<b>P2172</b>	<b>Threshold DC-link voltage</b>	<b>Min:</b> 0	<b>Level</b>
	<b>CStat:</b> CUT	<b>Datatype:</b> U16	<b>Unit:</b> V
	<b>P-Group:</b> ALARMS	<b>Active:</b> Immediately	<b>QuickComm.:</b> No
		<b>Def:</b> 800	<b>3</b>
		<b>Max:</b> 2000	

Defines DC link voltage to be compared to actual voltage as illustrated in the diagram below.

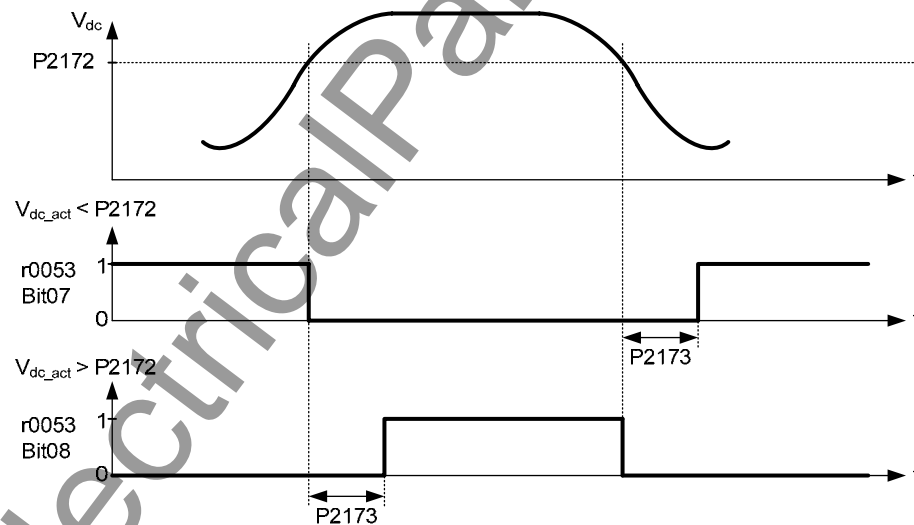

**Note:** This voltage controls bits 7 and 8 in status word 3 (r0053).  
Changing this threshold does not change the threshold of F0002 (Overvoltage).

<b>P2173</b>	<b>Delay time DC-link voltage</b>	<b>Min:</b> 0	<b>Level</b>
	<b>CStat:</b> CUT	<b>Datatype:</b> U16	<b>Unit:</b> ms
	<b>P-Group:</b> ALARMS	<b>Active:</b> Immediately	<b>QuickComm.:</b> No
		<b>Def:</b> 10	<b>3</b>
		<b>Max:</b> 10000	

Defines delay time prior to activation of threshold comparison.

**Details:** See diagram in P2172 (threshold DC-link voltage)

<b>P2179</b>	<b>Current limit for no load ident.</b>	<b>Min:</b> 0.0	<b>Level</b>
	<b>CStat:</b> CUT	<b>Datatype:</b> Float	<b>Def:</b> 3.0
	<b>P-Group:</b> ALARMS	<b>Active:</b> Immediately	<b>QuickComm.:</b> No
		<b>Max:</b> 10.0	<b>3</b>

Threshold current for A0922 (load missing) in [%] relative to P0305 (rated motor current) as illustrated in the diagram below.

**Load missing**

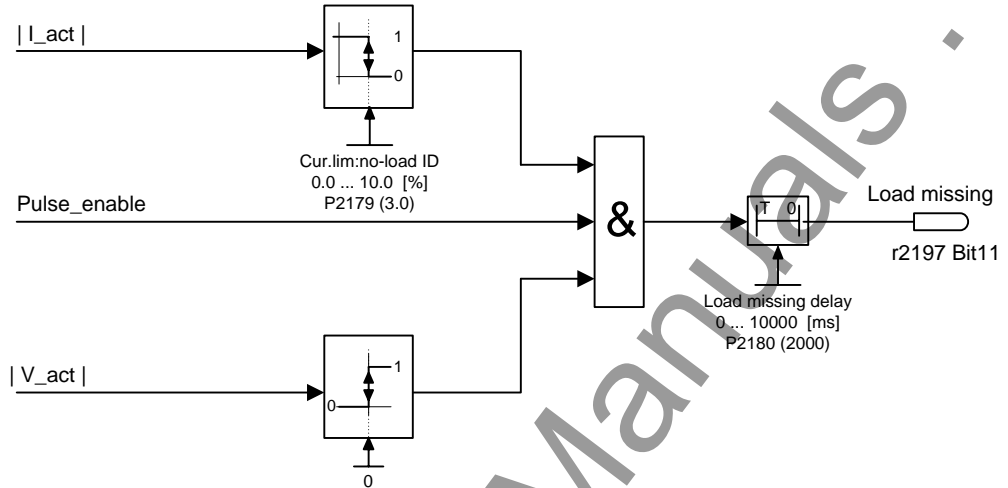

**Note:**

- It may be that the motor is not connected (load missing) or a phase could be missing.
- If a motor setpoint cannot be entered and the current limit (P2179) is not exceeded, Alarm A0922 (no load applied) is issued when delay time (P2180) expires.

<b>P2180</b>	<b>Delay time for load missing</b>	<b>Min:</b> 0	<b>Level</b>
	<b>CStat:</b> CUT	<b>Datatype:</b> U16	<b>Def:</b> 2000
	<b>P-Group:</b> ALARMS	<b>Active:</b> Immediately	<b>QuickComm.:</b> No
		<b>Max:</b> 10000	<b>3</b>

Delay time to identify that the current is less than the threshold defined in P2179.

**Details:**

See diagram in P2179 (current limit for no load identification).

<b>r2197</b>	<b>CO/BO: Monitoring word 1</b>	<b>Min:</b> -	<b>Level</b>
		<b>Datatype:</b> U16	<b>Def:</b> -
	<b>P-Group:</b> ALARMS	<b>Unit:</b> -	<b>Max:</b> -
			<b>2</b>

Monitoring word 1 which indicates the state of monitor functions. Each bit represents one monitor function.

**Bitfields:**

Bit00	f_act <= P1080 (f_min)	0	NO	1	YES
Bit01	f_act <= P2155 (f_1)	0	NO	1	YES
Bit02	f_act > P2155 (f_1)	0	NO	1	YES
Bit03	f_act > zero	0	NO	1	YES
Bit04	f_act >= setp. (f_set)	0	NO	1	YES
Bit05	f_act <= P2167 (f_off)	0	NO	1	YES
Bit06	f_act >= P1082 (f_max)	0	NO	1	YES
Bit07	f_act == setp. (f_set)	0	NO	1	YES
Bit08	Act. current r0027 > P2170	0	NO	1	YES
Bit09	Act. unfilt. Vdc < P2172	0	NO	1	YES
Bit10	Act. unfilt. Vdc > P2172	0	NO	1	YES
Bit11	Load missing	0	NO	1	YES

### 3.31 Technology controller (PID controller)

<b>P2200</b>	<b>BI: Enable PID controller</b>	<b>Datatype:</b> U32	<b>Unit:</b> -	<b>Min:</b> 0:0	<b>Level</b> <b>2</b>
	<b>CStat:</b> CUT	<b>Active:</b> first confirm	<b>QuickComm.:</b> No	<b>Def:</b> 0:0	
	<b>P-Group:</b> TECH			<b>Max:</b> 4000:0	

Allows user to enable/disable the PID controller.

**P2200 settings :**

- 0 : PID controller de-activated
- 1 : PID controller permanently activated
- BICO parameters : PID controller event-controlled, de-activated/activated

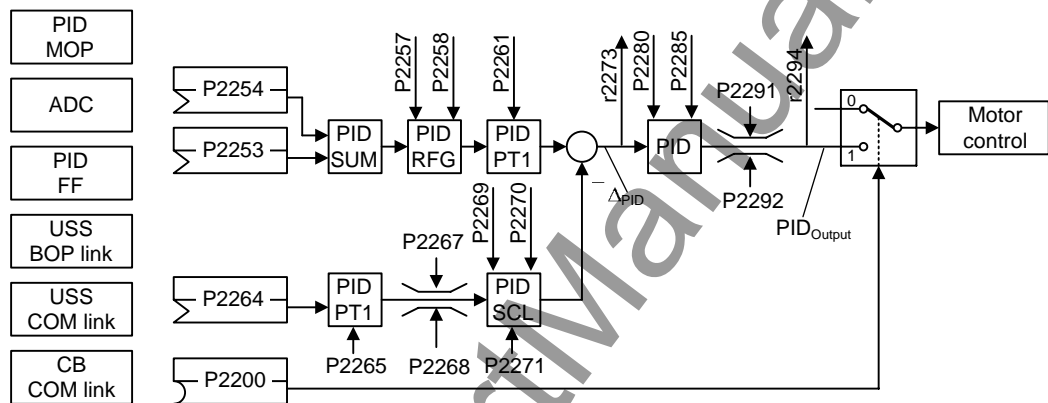

**Common Settings:**

Parameter	Parameter text	Setting	Meaning
P2200	BI: Enable PID controller	0	PID controller de-activated
		1.0	PID controller always active
		722.x	Digital input x
		BICO	BICO parameter
P2253	CI: PID setpoint	2224	Fixed PID setpoint (PID-FF)
		2250	PID-MOP
		2015.1	USS on BOP link
		2019.1	USS on COM link
		2050.1	CB on COM link
P2264	CI: PID feedback	755.0	Analog input

**Dependency:**

Setting 1 automatically disables normal ramp times set in P1120 and P1121 and the normal frequency setpoints.

Following an OFF1 or OFF3 command, however, the inverter frequency will ramp down to zero using the ramp time set in P1121 (P1135 for OFF3).

**Note:**

The PID setpoint source is selected using P2253. The PID setpoint and the PID feedback signal are interpreted as [%] values (not [Hz]). The output of the PID controller is displayed as [%] and then normalized into [Hz] through P2000 (reference frequency) when PID is enabled.

In level 3, the PID controller source enable can also come from the digital inputs in settings 722.0 to 722.2 for DIN1 to DIN3 or from any other BiCo source.

The minimum and maximum motor frequencies (P1080 and P1082) as well as the skip frequencies (P1091 to P1094) remain active on the inverter output. However, enabling skip frequencies with PID control can produce instabilities.

Changes in parameter P2200 are only activated on the next ON command!

<b>P2201</b>	<b>Fixed PID setpoint 1</b>			<b>Min:</b> -200.00	<b>Level</b> <b>2</b>
	<b>CStat:</b> CUT	<b>Datatype:</b> Float	<b>Unit:</b> %	<b>Def:</b> 0.00	
	<b>P-Group:</b> TECH	<b>Active:</b> Immediately	<b>QuickComm.:</b> No	<b>Max:</b> 200.00	

Defines Fixed PID Setpoint 1

There are three options available for selection of the PID fixed setpoints:

1. Direct selection
  2. Direct selection + ON command
  3. Binary coded selection + ON command
1. Direct selection (P0701 - P0706 = 15):
    - In this mode of operation, 1 digital input selects one PID fixed setpoint.
    - If several inputs are active together, the selected setpoints are summed.
    - E.g.: PID-FF1 + PID-FF2 + PID-FF3.
  2. Direct selection + ON command (P0701 - P0706 = 16):
    - In this mode of operation the PID fixed setpoints are combined with an ON command.
    - Description as for 1), except that this type of selection issues an ON command concurrent with any setpoint selection.
    - If several inputs are active together, the selected setpoints are summed.
    - E.g.: PID-FF1 + PID-FF2 + PID-FF3.
  3. Binary coded selection + ON command (P0701 - P0706 = 17):
    - Using this method to select the fixed PID setpoint (FF-PID) allows you to choose up to 8 different PID setpoints.
    - The setpoints are selected according to the following table:

**Example:**

Binary coded selection :

		DIN3	DIN2	DIN1
0 %	PID - FF0	0	0	0
P2201	PID - FF1	0	0	1
P2202	PID - FF2	0	1	0
P2203	PID - FF3	0	1	1
P2204	PID - FF4	1	0	0
P2205	PID - FF5	1	0	1
P2206	PID - FF6	1	1	0
P2207	PID - FF7	1	1	1

Direct selection of PID-FF1 P2201 via DIN 1:

P0701 = 15  
or  
P0701 = 99, P2220 = 722.0, P2216 = 1

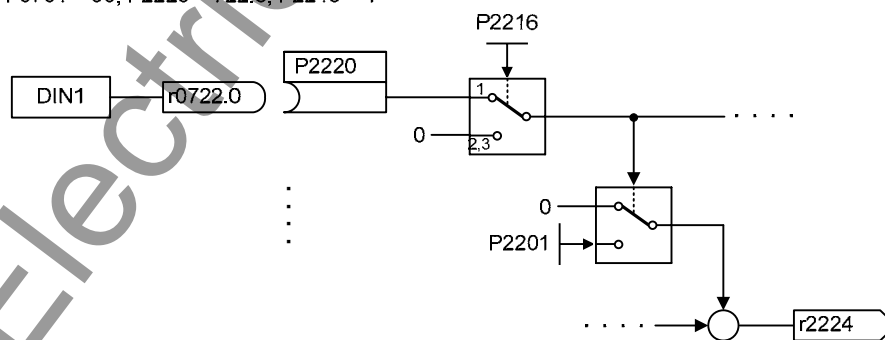

**Dependency:**

P2200 = 1 required in user access level 2 to enable setpoint source.

**Note:**

You may mix different types of frequencies; however, remember that they will be summed if selected together.

P2201 = 100 % corresponds to 4000 hex

<b>P2202</b>	<b>Fixed PID setpoint 2</b> CStat: CUT P-Group: TECH	Datatype: Float Active: Immediately	Unit: % QuickComm.: No	Min: -200.00 Def: 10.00 Max: 200.00	Level <b>2</b>
	Defines Fixed PID Setpoint 2 Details: See P2201 (Fixed PID Setpoint 1).				
<b>P2203</b>	<b>Fixed PID setpoint 3</b> CStat: CUT P-Group: TECH	Datatype: Float Active: Immediately	Unit: % QuickComm.: No	Min: -200.00 Def: 20.00 Max: 200.00	Level <b>2</b>
	Defines Fixed PID Setpoint 3 Details: See P2201 fixed PID setpoint 1 (FF-PID 1).				
<b>P2204</b>	<b>Fixed PID setpoint 4</b> CStat: CUT P-Group: TECH	Datatype: Float Active: Immediately	Unit: % QuickComm.: No	Min: -200.00 Def: 30.00 Max: 200.00	Level <b>2</b>
	Defines Fixed PID Setpoint 4 Details: See P2201 (Fixed PID Setpoint 1).				
<b>P2205</b>	<b>Fixed PID setpoint 5</b> CStat: CUT P-Group: TECH	Datatype: Float Active: Immediately	Unit: % QuickComm.: No	Min: -200.00 Def: 40.00 Max: 200.00	Level <b>2</b>
	Defines Fixed PID Setpoint 5 Details: See P2201 (Fixed PID Setpoint 1).				
<b>P2206</b>	<b>Fixed PID setpoint 6</b> CStat: CUT P-Group: TECH	Datatype: Float Active: Immediately	Unit: % QuickComm.: No	Min: -200.00 Def: 50.00 Max: 200.00	Level <b>2</b>
	Defines Fixed PID Setpoint 6 Details: See P2201 (Fixed PID Setpoint 1).				
<b>P2207</b>	<b>Fixed PID setpoint 7</b> CStat: CUT P-Group: TECH	Datatype: Float Active: Immediately	Unit: % QuickComm.: No	Min: -200.00 Def: 60.00 Max: 200.00	Level <b>2</b>
	Defines Fixed PID Setpoint 7 Details: See P2201 (Fixed PID Setpoint 1).				
<b>P2216</b>	<b>Fixed PID setpoint mode - Bit 0</b> CStat: CT P-Group: TECH	Datatype: U16 Active: first confirm	Unit: - QuickComm.: No	Min: 1 Def: 1 Max: 3	Level <b>3</b>
	Fixed frequencies for PID setpoint can be selected in three different modes. Parameter P2216 defines the mode of selection Bit 0. Possible Settings: 1 Direct selection 2 Direct selection + ON command 3 Binary coded selection + ON command				
<b>P2217</b>	<b>Fixed PID setpoint mode - Bit 1</b> CStat: CT P-Group: TECH	Datatype: U16 Active: first confirm	Unit: - QuickComm.: No	Min: 1 Def: 1 Max: 3	Level <b>3</b>
	BCD or direct selection Bit 1 for PID setpoint. Possible Settings: 1 Direct selection 2 Direct selection + ON command 3 Binary coded selection + ON command				
<b>P2218</b>	<b>Fixed PID setpoint mode - Bit 2</b> CStat: CT P-Group: TECH	Datatype: U16 Active: first confirm	Unit: - QuickComm.: No	Min: 1 Def: 1 Max: 3	Level <b>3</b>
	BCD or direct selection Bit 2 for PID setpoint. Possible Settings: 1 Direct selection 2 Direct selection + ON command 3 Binary coded selection + ON command				

<b>P2220</b>	<b>BI: Fixed PID setp. select Bit 0</b>	<b>Min:</b> 0:0	Level <b>3</b>
	<b>CStat:</b> CT <b>Datatype:</b> U32 <b>Unit:</b> - <b>Def:</b> 0:0		
	<b>P-Group:</b> COMMANDS <b>Active:</b> first confirm <b>QuickComm.:</b> No <b>Max:</b> 4000:0		

Defines command source of fixed PID setpoint selection Bit 0

**Common Settings:**

- 722.0 = Digital input 1 (requires P0701 to be set to 99, BICO)
- 722.1 = Digital input 2 (requires P0702 to be set to 99, BICO)
- 722.2 = Digital input 3 (requires P0703 to be set to 99, BICO)
- 722.3 = Digital input 4 (via analog input, requires P0704 to be set to 99)

<b>P2221</b>	<b>BI: Fixed PID setp. select Bit 1</b>	<b>Min:</b> 0:0	Level <b>3</b>
	<b>CStat:</b> CT <b>Datatype:</b> U32 <b>Unit:</b> - <b>Def:</b> 0:0		
	<b>P-Group:</b> COMMANDS <b>Active:</b> first confirm <b>QuickComm.:</b> No <b>Max:</b> 4000:0		

Defines command source of fixed PID setpoint selection Bit 1.

**Common Settings:**

- 722.0 = Digital input 1 (requires P0701 to be set to 99, BICO)
- 722.1 = Digital input 2 (requires P0702 to be set to 99, BICO)
- 722.2 = Digital input 3 (requires P0703 to be set to 99, BICO)

<b>P2222</b>	<b>BI: Fixed PID setp. select Bit 2</b>	<b>Min:</b> 0:0	Level <b>3</b>
	<b>CStat:</b> CT <b>Datatype:</b> U32 <b>Unit:</b> - <b>Def:</b> 0:0		
	<b>P-Group:</b> COMMANDS <b>Active:</b> first confirm <b>QuickComm.:</b> No <b>Max:</b> 4000:0		

Defines command source of fixed PID setpoint selection Bit 2

**Common Settings:**

- 722.0 = Digital input 1 (requires P0701 to be set to 99, BICO)
- 722.1 = Digital input 2 (requires P0702 to be set to 99, BICO)
- 722.2 = Digital input 3 (requires P0703 to be set to 99, BICO)

<b>r2224</b>	<b>CO: Act. fixed PID setpoint</b>	<b>Min:</b> -	Level <b>2</b>
	<b>Datatype:</b> Float <b>Unit:</b> %	<b>Def:</b> -	
	<b>P-Group:</b> TECH	<b>Max:</b> -	

Displays total output of PID fixed setpoint selection.

**Note:**

r2224 = 100 % corresponds to 4000 hex

<b>P2231</b>	<b>Setpoint memory of PID-MOP</b>	<b>Min:</b> 0	Level <b>2</b>
	<b>CStat:</b> CUT <b>Datatype:</b> U16 <b>Unit:</b> - <b>Def:</b> 0		
	<b>P-Group:</b> TECH <b>Active:</b> Immediately <b>QuickComm.:</b> No <b>Max:</b> 1		

Setpoint memory

**Possible Settings:**

- 0 PID-MOP setpoint will not be stored
- 1 PID-MOP setpoint will be stored (P2240 is updated)

**Dependency:**

If 0 selected, setpoint returns to value set in P2240 (setpoint of PID-MOP) after an OFF command.

If 1 is selected, active setpoint is "remembered" and P2240 updated with current value.

**Details:**

See P2240 (setpoint of PID-MOP)

<b>P2232</b>	<b>Inhibit neg. PID-MOP setpoints</b>	<b>Min:</b> 0	Level <b>2</b>
	<b>CStat:</b> CT <b>Datatype:</b> U16 <b>Unit:</b> - <b>Def:</b> 1		
	<b>P-Group:</b> TECH <b>Active:</b> first confirm <b>QuickComm.:</b> No <b>Max:</b> 1		

This parameter suppresses negative setpoints of the PID-MOP output r2250.

**Possible Settings:**

- 0 Neg. PID-MOP setpoint is allowed
- 1 Neg. PID-MOP setpoint inhibited

**Note:**

Setting 0 enables a change of motor direction using the motor potentiometer setpoint (increase/decrease frequency either by using digital inputs or motor potentiometer up/down buttons).

<b>P2235</b>	<b>BI: Enable PID-MOP (UP-cmd)</b>	<b>Min:</b> 0:0	<b>Level</b> <b>3</b>	
	<b>CStat:</b> CT	<b>Datatype:</b> U32		<b>Def:</b> 19:13
	<b>P-Group:</b> COMMANDS	<b>Active:</b> first confirm		<b>QuickComm.:</b> No

Defines source of UP command.

**Common Settings:**

- 722.0 = Digital input 1 (requires P0701 to be set to 99, BICO)
- 722.1 = Digital input 2 (requires P0702 to be set to 99, BICO)
- 722.2 = Digital input 3 (requires P0703 to be set to 99, BICO)
- 19.D = Keypad UP button

**Dependency:**

- To change setpoint:
1. Use UP / DOWN key on BOP or
  2. Set P0702/P0703 = 13/14 (function of digital inputs 2 and 3)

<b>P2236</b>	<b>BI: Enable PID-MOP (DOWN-cmd)</b>	<b>Min:</b> 0:0	<b>Level</b> <b>3</b>	
	<b>CStat:</b> CT	<b>Datatype:</b> U32		<b>Def:</b> 19:14
	<b>P-Group:</b> COMMANDS	<b>Active:</b> first confirm		<b>QuickComm.:</b> No

Defines source of DOWN command.

**Common Settings:**

- 722.0 = Digital input 1 (requires P0701 to be set to 99, BICO)
- 722.1 = Digital input 2 (requires P0702 to be set to 99, BICO)
- 722.2 = Digital input 3 (requires P0703 to be set to 99, BICO)
- 722.3 = Digital input 4 (via analog input, requires P0704 to be set to 99)
- 19.E = Keypad DOWN button

**Dependency:**

- To change setpoint:
1. Use UP / DOWN key on BOP or
  2. Set P0702/P0703 = 13/14 (function of digital inputs 2 and 3)

<b>P2240</b>	<b>Setpoint of PID-MOP</b>	<b>Min:</b> -200.00	<b>Level</b> <b>2</b>	
	<b>CStat:</b> CUT	<b>Datatype:</b> Float		<b>Def:</b> 10.00
	<b>P-Group:</b> TECH	<b>Active:</b> Immediately		<b>QuickComm.:</b> No

Setpoint of the motor potentiometer.

Allows user to set a digital PID setpoint in [%].

**Note:**

P2240 = 100 % corresponds to 4000 hex

<b>r2250</b>	<b>CO: Output setpoint of PID-MOP</b>	<b>Min:</b> -	<b>Level</b> <b>2</b>	
		<b>Datatype:</b> Float		<b>Def:</b> -
	<b>P-Group:</b> TECH	<b>Unit:</b> %		<b>Max:</b> -

Displays output setpoint of motor potentiometer in [%].

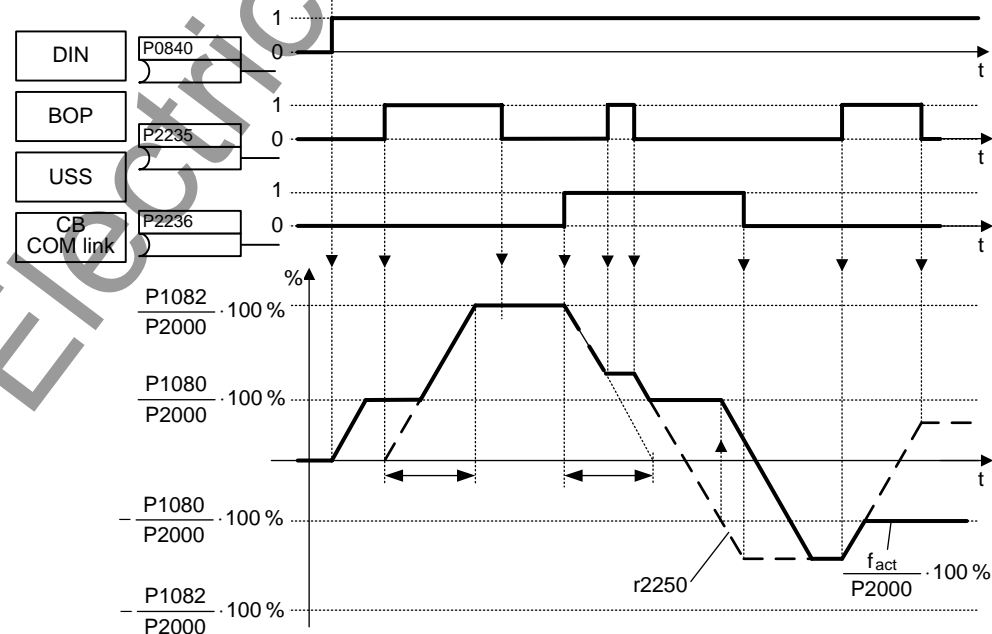

**Note:**

r2250 = 100 % corresponds to 4000 hex

<b>P2253</b>	<b>CI: PID setpoint</b>	<b>Datatype:</b> U32	<b>Unit:</b> -	<b>Min:</b> 0:0	Level <b>2</b>
	<b>CStat:</b> CUT	<b>Active:</b> first confirm	<b>QuickComm.:</b> No	<b>Def:</b> 0:0	
	<b>P-Group:</b> TECH			<b>Max:</b> 4000:0	

Defines setpoint source for PID setpoint input.

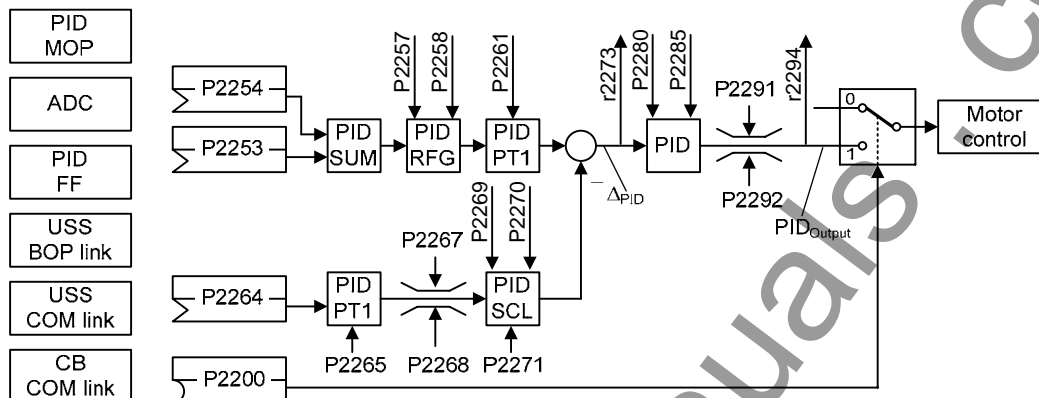

**Common Settings:**

Parameter	Parameter text	Setting	Meaning
P2200	BI: Enable PID controller	0	PID controller de-activated
		1.0	PID controller always active
		722.x	Digital input x
		BICO	BICO parameter
P2253	CI: PID setpoint	2224	Fixed PID setpoint (PID-FF)
		2250	PID-MOP
		2015.1	USS on BOP link
		2019.1	USS on COM link
		2050.1	CB on COM link
P2264	CI: PID feedback	755.0	Analog input

<b>P2254</b>	<b>CI: PID trim source</b>	<b>Datatype:</b> U32	<b>Unit:</b> -	<b>Min:</b> 0:0	Level <b>3</b>
	<b>CStat:</b> CUT	<b>Active:</b> first confirm	<b>QuickComm.:</b> No	<b>Def:</b> 0:0	
	<b>P-Group:</b> TECH			<b>Max:</b> 4000:0	

Selects trim source for PID setpoint. This signal is multiplied by the trim gain and added to the PID setpoint.

**Common Settings:**

See parameter P2253

<b>P2255</b>	<b>PID setpoint gain factor</b>	<b>Datatype:</b> Float	<b>Unit:</b> -	<b>Min:</b> 0.00	Level <b>3</b>
	<b>CStat:</b> CUT	<b>Active:</b> Immediately	<b>QuickComm.:</b> No	<b>Def:</b> 100.00	
	<b>P-Group:</b> TECH			<b>Max:</b> 100.00	

Gain factor for PID setpoint. The PID setpoint input is multiplied by this gain factor to produce a suitable ratio between setpoint and trim.

<b>P2256</b>	<b>PID trim gain factor</b>	<b>Datatype:</b> Float	<b>Unit:</b> -	<b>Min:</b> 0.00	Level <b>3</b>
	<b>CStat:</b> CUT	<b>Active:</b> Immediately	<b>QuickComm.:</b> No	<b>Def:</b> 100.00	
	<b>P-Group:</b> TECH			<b>Max:</b> 100.00	

Gain factor for PID trim. This gain factor scales the trim signal, which is added to the main PID setpoint.

<b>P2257</b>	<b>Ramp-up time for PID setpoint</b>	<b>Min:</b> 0.00	<b>Level</b> <b>2</b>	
	<b>CStat:</b> CUT	<b>Datatype:</b> Float		<b>Unit:</b> s
	<b>P-Group:</b> TECH	<b>Active:</b> Immediately		<b>QuickComm.:</b> No

Sets the ramp-up time for the PID setpoint.

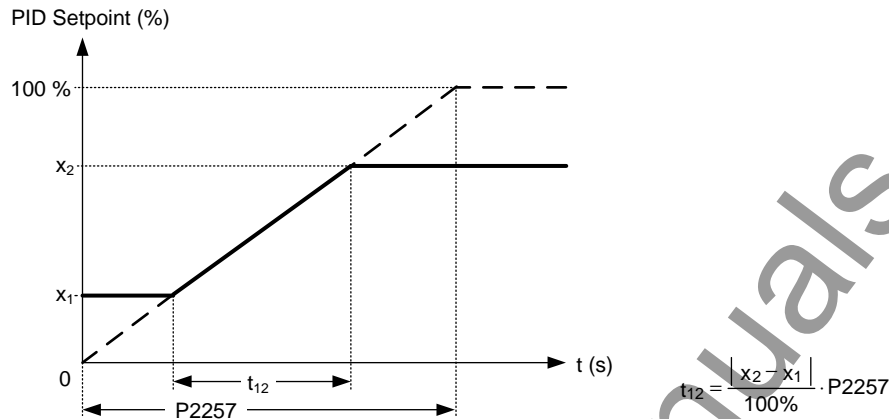

**Dependency:**

P2200 = 1 (PID control is enabled) disables normal ramp-up time (P1120).

PID ramp time effective only on PID setpoint and only active

- when PID setpoint is changed or
- when RUN command is given.

**Notice:**

Setting the ramp-up time too short may cause the inverter to trip, on overcurrent for example.

<b>P2258</b>	<b>Ramp-down time for PID setpoint</b>	<b>Min:</b> 0.00	<b>Level</b> <b>2</b>	
	<b>CStat:</b> CUT	<b>Datatype:</b> Float		<b>Unit:</b> s
	<b>P-Group:</b> TECH	<b>Active:</b> Immediately		<b>QuickComm.:</b> No

Sets ramp-down time for PID setpoint.

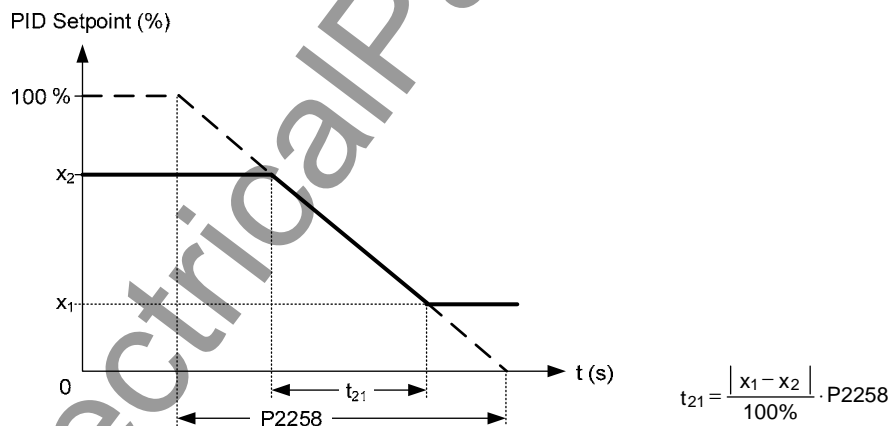

**Dependency:**

- P2200 = 1 (PID control is enabled) disables normal ramp-up time (P1120).

- PID setpoint ramp effective only on PID setpoint changes.

- P1121 (ramp-down time) and P1135 (OFF3 ramp-down time) define the ramp times used after OFF1 and OFF3 respectively.

**Notice:**

Setting the ramp-down time too short can cause the inverter to trip on overvoltage (F0002) / overcurrent (F0001).

<b>r2260</b>	<b>CO: PID setpoint after PID-RFG</b>	<b>Min:</b> -	<b>Level</b> <b>2</b>	
		<b>Datatype:</b> Float		<b>Unit:</b> %
	<b>P-Group:</b> TECH	<b>Max:</b> -		

Displays total active PID setpoint after PID-RFG in [%].

**Note:**

r2260 = 100 % corresponds to 4000 hex

<b>P2261</b>	<b>PID setpoint filter timeconstant</b>	<b>Min:</b> 0.00	<b>Level</b>
<b>CStat:</b> CUT	<b>Datatype:</b> Float	<b>Unit:</b> s	<b>Def:</b> 0.00
<b>P-Group:</b> TECH	<b>Active:</b> Immediately	<b>QuickComm.:</b> No	<b>Max:</b> 60.00
			<b>3</b>

Sets a time constant for smoothing the PID setpoint.

**Note:**

0 = no smoothing

<b>r2262</b>	<b>CO: Filtered PID setp. after RFG</b>	<b>Min:</b> -	<b>Level</b>
	<b>Datatype:</b> Float	<b>Unit:</b> %	<b>Def:</b> -
<b>P-Group:</b> TECH			<b>Max:</b> -
			<b>3</b>

Displays the filtered PID setpoint after the PID ramp-function generator (PID\_HLG) as percentage. Parameter r2262 is obtained from the filtered parameter r2260 that is filtered using the PT1 filter with time constant P2261.

**Note:**

r2262 = 100 % corresponds to 4000 hex

<b>P2264</b>	<b>CI: PID feedback</b>	<b>Min:</b> 0:0	<b>Level</b>
<b>CStat:</b> CUT	<b>Datatype:</b> U32	<b>Unit:</b> -	<b>Def:</b> 755:0
<b>P-Group:</b> TECH	<b>Active:</b> first confirm	<b>QuickComm.:</b> No	<b>Max:</b> 4000:0
			<b>2</b>

Selects the source of the PID feedback signal.

**Common Settings:**

Parameter	Parameter text	Setting	Meaning
P2200	BI: Enable PID controller	0	PID controller de-activated
		1.0	PID controller always active
		722.x	Digital input x
		BICO	BICO parameter
P2253	CI: PID setpoint	2224	Fixed PID setpoint (PID-FF)
		2250	PID-MOP
		2015.1	USS on BOP link
		2019.1	USS on COM link
		2050.1	CB on COM link
P2264	CI: PID feedback	755.0	Analog input

**Note:**

When analog input is selected, offset and gain can be implemented using parameters P0756 to P0760.

<b>P2265</b>	<b>PID feedback filter timeconstant</b>	<b>Min:</b> 0.00	<b>Level</b>
<b>CStat:</b> CUT	<b>Datatype:</b> Float	<b>Unit:</b> s	<b>Def:</b> 0.00
<b>P-Group:</b> TECH	<b>Active:</b> Immediately	<b>QuickComm.:</b> No	<b>Max:</b> 60.00
			<b>2</b>

Defines time constant for PID feedback filter.

<b>r2266</b>	<b>CO: PID filtered feedback</b>	<b>Min:</b> -	<b>Level</b>
	<b>Datatype:</b> Float	<b>Unit:</b> %	<b>Def:</b> -
<b>P-Group:</b> TECH			<b>Max:</b> -
			<b>2</b>

Displays PID feedback signal in [%].

**Note:**

r2266 = 100 % corresponds to 4000 hex

<b>P2267</b>	<b>Max. value for PID feedback</b>	<b>Min:</b> -200.00	<b>Level</b>
<b>CStat:</b> CUT	<b>Datatype:</b> Float	<b>Unit:</b> %	<b>Def:</b> 100.00
<b>P-Group:</b> TECH	<b>Active:</b> Immediately	<b>QuickComm.:</b> No	<b>Max:</b> 200.00
			<b>3</b>

Sets the upper limit for the value of the feedback signal in [%].

**Note:**

- P2267 = 100 % corresponds to 4000 hex
- When PID is enabled (P2200 = 1) and the signal rises above this value, the inverter will trip with F0222 .

<b>P2268</b>	<b>Min. value for PID feedback</b>	<b>Min:</b> -200.00	<b>Level</b>
<b>CStat:</b> CUT	<b>Datatype:</b> Float	<b>Unit:</b> %	<b>Def:</b> 0.00
<b>P-Group:</b> TECH	<b>Active:</b> Immediately	<b>QuickComm.:</b> No	<b>Max:</b> 200.00
			<b>3</b>

Sets lower limit for value of feedback signal in [%].

**Note:**

- P2268 = 100 % corresponds to 4000 hex
- When PID is enabled (P2200 = 1) and the signal rises below this value, the inverter will trip with F0221.

<b>P2269</b>	<b>Gain applied to PID feedback</b>	<b>Min:</b> 0.00	Level
	<b>CStat:</b> CUT	<b>Datatype:</b> Float	<b>Def:</b> 100.00
	<b>P-Group:</b> TECH	<b>Unit:</b> -	<b>Max:</b> 500.00

**3**

Allows the user to scale the PID feedback as a percentage value [%].

A gain of 100.0 % means that feedback signal has not changed from its default value.

<b>P2270</b>	<b>PID feedback function selector</b>	<b>Min:</b> 0	Level
	<b>CStat:</b> CUT	<b>Datatype:</b> U16	<b>Def:</b> 0
	<b>P-Group:</b> TECH	<b>Unit:</b> -	<b>Max:</b> 3

**3**

Applies mathematical functions to the PID feedback signal, allowing multiplication of the result by P2269 (gain applied to PID feedback).

**Possible Settings:**

- 0 Disabled
- 1 Square root (root(x))
- 2 Square (x\*x)
- 3 Cube (x\*x\*x)

<b>P2271</b>	<b>PID transducer type</b>	<b>Min:</b> 0	Level
	<b>CStat:</b> CUT	<b>Datatype:</b> U16	<b>Def:</b> 0
	<b>P-Group:</b> TECH	<b>Unit:</b> -	<b>Max:</b> 1

**2**

Allows the user to select the transducer type for the PID feedback signal.

**Possible Settings:**

- 0 Disabled
- 1 Inversion of PID feedback signal

**Notice:**

It is essential that you select the correct transducer type.

If you are unsure whether 0 or 1 is applicable, you can determine the correct type as follows:

1. Disable the PID function (P2200 = 0).
2. Increase the motor frequency while measuring the feedback signal.
3. If the feedback signal increases with an increase in motor frequency, the PID transducer type should be 0.
4. If the feedback signal decreases with an increase in motor frequency the PID transducer type should be set to 1.

<b>r2272</b>	<b>CO: PID scaled feedback</b>	<b>Min:</b> -	Level
	<b>Datatype:</b> Float	<b>Def:</b> -	<b>2</b>
	<b>Unit:</b> %	<b>Max:</b> -	

Displays PID scaled feedback signal in [%].

**Note:**

r2272 = 100 % corresponds to 4000 hex

<b>r2273</b>	<b>CO: PID error</b>	<b>Min:</b> -	Level
	<b>Datatype:</b> Float	<b>Def:</b> -	<b>2</b>
	<b>Unit:</b> %	<b>Max:</b> -	

Displays PID error (difference) signal between setpoint and feedback signals in [%].

**Note:**

r2273 = 100 % corresponds to 4000 hex

<b>P2280</b>	<b>PID proportional gain</b>	<b>Datatype:</b> Float	<b>Unit:</b> -	<b>Min:</b> 0.000	Level <b>2</b>
	<b>CStat:</b> CUT	<b>Active:</b> Immediately	<b>QuickComm.:</b> No	<b>Def:</b> 3.000	
	<b>P-Group:</b> TECH			<b>Max:</b> 65.000	

Allows user to set proportional gain for PID controller.

The PID controller is implemented using the standard model.

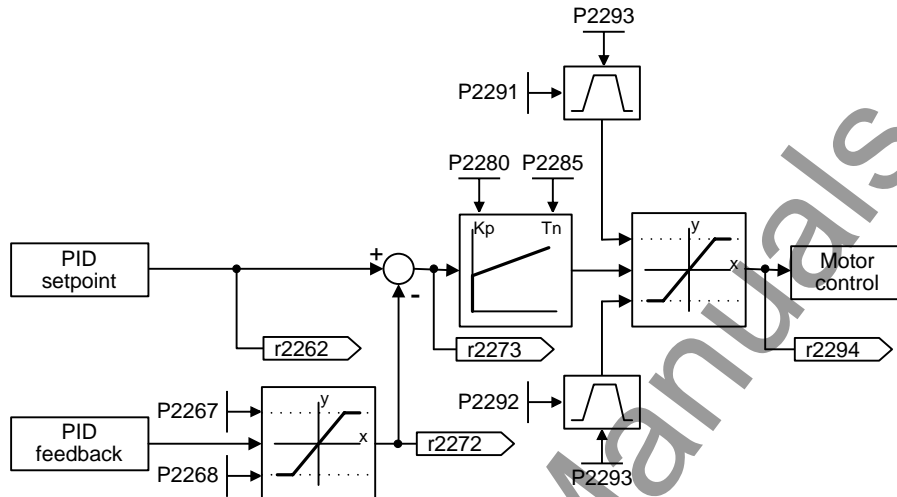

For best results, enable both P and I terms.

**Dependency:**

P2280 = 0 (P term of PID = 0):  
I term acts on the square of the error signal.

P2285 = 0 (I term of PID = 0):  
PID controller acts as a P or PD controller respectively.

**Note:**

- If the system is prone to sudden step changes in the feedback signal, P term should normally be set to a small value (0.5) with a faster I term for optimum performance.

<b>P2285</b>	<b>PID integral time</b>	<b>Datatype:</b> Float	<b>Unit:</b> s	<b>Min:</b> 0.000	Level <b>2</b>
	<b>CStat:</b> CUT	<b>Active:</b> Immediately	<b>QuickComm.:</b> No	<b>Def:</b> 0.000	
	<b>P-Group:</b> TECH			<b>Max:</b> 60.000	

Sets integral time constant for PID controller.

**Details:**

See P2280 (PID proportional gain).

<b>P2291</b>	<b>PID output upper limit</b>	<b>Datatype:</b> Float	<b>Unit:</b> %	<b>Min:</b> -200.00	Level <b>2</b>
	<b>CStat:</b> CUT	<b>Active:</b> Immediately	<b>QuickComm.:</b> No	<b>Def:</b> 100.00	
	<b>P-Group:</b> TECH			<b>Max:</b> 200.00	

Sets upper limit for PID controller output in [%].

**Dependency:**

If F max (P1082) is greater than P2000 (reference frequency), either P2000 or P2291 (PID output upper limit) must be changed to achieve F max.

**Note:**

P2291 = 100 % corresponds to 4000 hex (as defined by P2000 (reference frequency)).

<b>P2292</b>	<b>PID output lower limit</b>	<b>Datatype:</b> Float	<b>Unit:</b> %	<b>Min:</b> -200.00	Level <b>2</b>
	<b>CStat:</b> CUT	<b>Active:</b> Immediately	<b>QuickComm.:</b> No	<b>Def:</b> 0.00	
	<b>P-Group:</b> TECH			<b>Max:</b> 200.00	

Sets lower limit for the PID controller output in [%].

**Dependency:**

A negative value allows bipolar operation of PID controller.

**Note:**

P2292 = 100 % corresponds to 4000 hex

<b>P2293</b>	<b>Ramp-up /-down time of PID limit</b>			<b>Min:</b> 0.00	Level <b>3</b>
	<b>CStat:</b> CUT	<b>Datatype:</b> Float	<b>Unit:</b> s	<b>Def:</b> 1.00	
	<b>P-Group:</b> TECH	<b>Active:</b> Immediately	<b>QuickComm.:</b> No	<b>Max:</b> 100.00	

Sets maximum ramp rate on output of PID.

When PI is enabled, the output limits are ramped up from 0 to the limits set in P2291 (PID output upper limit) and P2292 (PID output lower limit). Limits prevent large step changes appearing on the output of the PID when the inverter is started. Once the limits have been reached, the PID controller output is instantaneous.

These ramp times are used whenever a RUN command is issued.

**Note:**

If an OFF1 or OFF 3 are issued, the inverter output frequency ramps down as set in P1121 (ramp-down time) or P1135 (OFF3 ramp-down time).

<b>r2294</b>	<b>CO: Act. PID output</b>			<b>Min:</b> -	Level <b>2</b>
		<b>Datatype:</b> Float	<b>Unit:</b> %	<b>Def:</b> -	
	<b>P-Group:</b> TECH			<b>Max:</b> -	

Displays PID output in [%]

**Note:**

r2294 = 100 % corresponds to 4000 hex

### 3.32 Inverter parameters

<b>P3900</b>	<b>End of quick commissioning</b>				Min: 0	Level <b>1</b>
	CStat: C	Datatype: U16	Unit: -	Def: 0		
	P-Group: QUICK	Active: first confirm	QuickComm.: Yes	Max: 3		

Performs calculations necessary for optimized motor operation.

After completion of calculation, P3900 and P0010 (parameter groups for commissioning) are automatically reset to their original value 0.

**Possible Settings:**

- 0 No quick commissioning
- 1 Start quick commissioning with factory reset
- 2 Start quick commissioning
- 3 Start quick commissioning only for motor data

**Dependency:**

Changeable only when P0010 = 1 (quick commissioning)

**Note:**

P3900 = 1 :

When setting 1 is selected, only the parameter settings carried out via the commissioning menu "Quick commissioning", are retained; all other parameter changes, including the I/O settings, are lost. Motor calculations are also performed.

P3900 = 2 :

When setting 2 is selected, only those parameters, which depend on the parameters in the commissioning menu "Quick commissioning" (P0010 = 1) are calculated. The I/O settings are also reset to default and the motor calculations performed.

P3900 = 3 :

When setting 3 is selected, only the motor and controller calculations are performed. Exiting quick commissioning with this setting saves time (for example, if only motor rating plate data have been changed).

Calculates a variety of motor parameters, overwriting previous values (see parameter P0340, setting P0340 = 1).

<b>P3950</b>	<b>Access of hidden parameters</b>				Min: 0	Level <b>4</b>
	CStat: CUT	Datatype: U16	Unit: -	Def: 0		
	P-Group: ALWAYS	Active: first confirm	QuickComm.: No	Max: 255		

Accesses special parameters for development (expert only) and factory functionality (calibration parameter).

<b>r3954[13]</b>	<b>CM version and GUI ID</b>				Min: -	Level <b>4</b>
	Datatype: U16		Unit: -	Def: -		
	P-Group: -		Max: -			

Used to classify firmware (only for SIEMENS internal purposes).

**Index:**

- r3954[0] : CM version (major release)
- r3954[1] : CM version (minor release)
- r3954[2] : CM version (baselevel or patch)
- r3954[3] : GUI ID
- r3954[4] : GUI ID
- r3954[5] : GUI ID
- r3954[6] : GUI ID
- r3954[7] : GUI ID
- r3954[8] : GUI ID
- r3954[9] : GUI ID
- r3954[10] : GUI ID
- r3954[11] : GUI ID major release
- r3954[12] : GUI ID minor release

<b>P3980</b>	<b>Commissioning command selection</b>				<b>Min:</b> 0	<b>Level</b> <b>4</b>
	<b>CStat:</b> T	<b>Datatype:</b> U16	<b>Unit:</b> -	<b>Def:</b> 0		
	<b>P-Group:</b> -	<b>Active:</b> first confirm	<b>QuickComm.:</b> No	<b>Max:</b> 67		

Toggles command and setpoint sources between freely programmable BICO parameters and fixed command/setpoint profiles for commissioning.

The command and setpoint sources can be changed independently. The tens digit selects the command source, the ones digit the setpoint source.

**Possible Settings:**

0	Cmd = BICO parameter	Setpoint = BICO parameter
1	Cmd = BICO parameter	Setpoint = MOP setpoint
2	Cmd = BICO parameter	Setpoint = Analog setpoint
3	Cmd = BICO parameter	Setpoint = Fixed frequency
4	Cmd = BICO parameter	Setpoint = USS on BOP link
5	Cmd = BICO parameter	Setpoint = USS on COM link
6	Cmd = BICO parameter	Setpoint = CB on COM link
7	Cmd = BICO parameter	Setpoint = Analog 2 setp
10	Cmd = BOP	Setpoint = BICO parameter
11	Cmd = BOP	Setpoint = MOP setpoint
12	Cmd = BOP	Setpoint = Analog setpoint
13	Cmd = BOP	Setpoint = Fixed frequency
15	Cmd = BOP	Setpoint = USS on COM link
16	Cmd = BOP	Setpoint = CB on COM link
17	Cmd = BOP	Setpoint = Analog 2 setp
40	Cmd = USS on BOP link	Setpoint = BICO parameter
41	Cmd = USS on BOP link	Setpoint = MOP setpoint
42	Cmd = USS on BOP link	Setpoint = Analog setpoint
43	Cmd = USS on BOP link	Setpoint = Fixed frequency
44	Cmd = USS on BOP link	Setpoint = USS on BOP link
45	Cmd = USS on BOP link	Setpoint = USS on COM link
46	Cmd = USS on BOP link	Setpoint = CB on COM link
47	Cmd = USS on BOP link	Setpoint = Analog 2 setp
50	Cmd = USS on COM link	Setpoint = BICO parameter
51	Cmd = USS on COM link	Setpoint = MOP setpoint
52	Cmd = USS on COM link	Setpoint = Analog setpoint
53	Cmd = USS on COM link	Setpoint = Fixed frequency
54	Cmd = USS on COM link	Setpoint = USS on BOP link
55	Cmd = USS on COM link	Setpoint = USS on COM link
57	Cmd = USS on COM link	Setpoint = Analog 2 setp
60	Cmd = CB on COM link	Setpoint = BICO parameter
61	Cmd = CB on COM link	Setpoint = MOP setpoint
62	Cmd = CB on COM link	Setpoint = Analog setpoint
63	Cmd = CB on COM link	Setpoint = Fixed frequency
64	Cmd = CB on COM link	Setpoint = USS on BOP link
66	Cmd = CB on COM link	Setpoint = CB on COM link
67	Cmd = CB on COM link	Setpoint = Analog 2 setp

<b>P3981</b>	<b>Reset active fault</b>				<b>Min:</b> 0	<b>Level</b> <b>4</b>
	<b>CStat:</b> CT	<b>Datatype:</b> U16	<b>Unit:</b> -	<b>Def:</b> 0		
	<b>P-Group:</b> ALARMS	<b>Active:</b> first confirm	<b>QuickComm.:</b> No	<b>Max:</b> 1		

Resets active faults when changed from 0 to 1.

**Possible Settings:**

0	No fault reset
1	Reset fault

**Note:**

Automatically reset to 0.

**Details:**

See r0947 (last fault code)















<b>r3986[2]</b>	<b>Number of parameters</b>				<b>Min:</b> -	<b>Level</b> <b>4</b>
					<b>Def:</b> -	
	<b>P-Group:</b> -	<b>Datatype:</b> U16	<b>Unit:</b> -	<b>Max:</b> -		

Number of parameters on the drive

**Index:**

r3986[0]	: Read only
r3986[1]	: Read & write

# 4 Function Diagrams

Explanation of symbols used in the function diagrams											
<p><b>Setting parameters</b></p> <p>Parameter text                      Min ... Max [Dim]                      PNumber.C/D [3] (Default)</p> <p><b>Monitoring parameters</b></p> <p>Parameter text [Unit]                      Parameter number.Command/Drive data set [Number indexes] (Default)</p> <p><b>BICO parameters</b></p> <p>Binector input (Setting parameter)                      Parameter text [Unit]                      PNum.C/D [3] (Default)</p> <p>Binector output (Monitoring parameter)                      Parameter text                      PNum</p> <p>Connector input (Setting parameter)                      Parameter text                      PNum.C/D [3] (Default)</p> <p>Connector output (Monitoring parameter)                      Parameter text [Unit]                      PNum [3]</p> <p>Connector/Binector output (Monitoring parameter)                      Parameter text                      PNum                      PNum</p>	<p>Summation</p> <p>Multiplication</p> <p>Division</p> <p>Switch</p> <p>Selection switch (1 out of 4)</p> <p>ON delay</p> <p>OFF delay</p> <p>ON and OFF delay</p> <p>AND gate</p> <p>OR gate</p> <p>NOT gate</p> <p>NOT gate</p> <p>A/D converter</p> <p>D/A converter</p>	<p>Filter element</p> <p>Gain element</p> <p>Integrator</p> <p>PI controller</p> <p>Differentiator</p> <p>Limitation</p> <p>Limitation</p> <p>Characteristic</p> <p>Hysteresis</p>	             	<p>1</p>	<p>2</p>	<p>3</p>	<p>4</p>	<p>5</p>	<p>6</p>	<p>7</p>	<p>8</p>
Symbols in function diagrams											
										0010_Symbols.vsd	Function diagram
										16.08.2006	V1.2
										MICROMASTER 420	

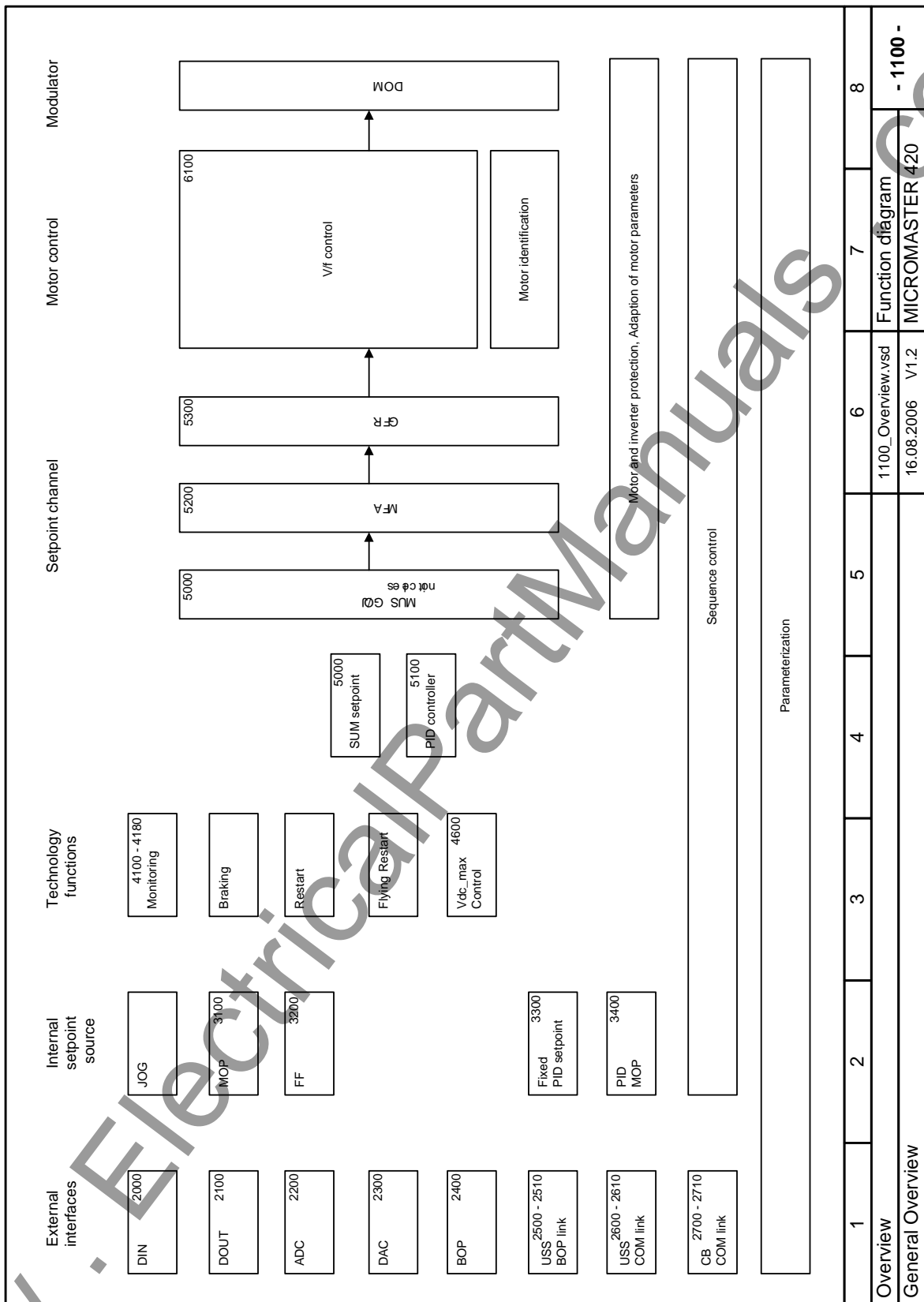

1	2	3	4	5	6	7	8
Overview					1100_Overview.vsd	Function diagram	
General Overview					16.08.2006 V1.2	MICROMASTER 420 - 1100 -	

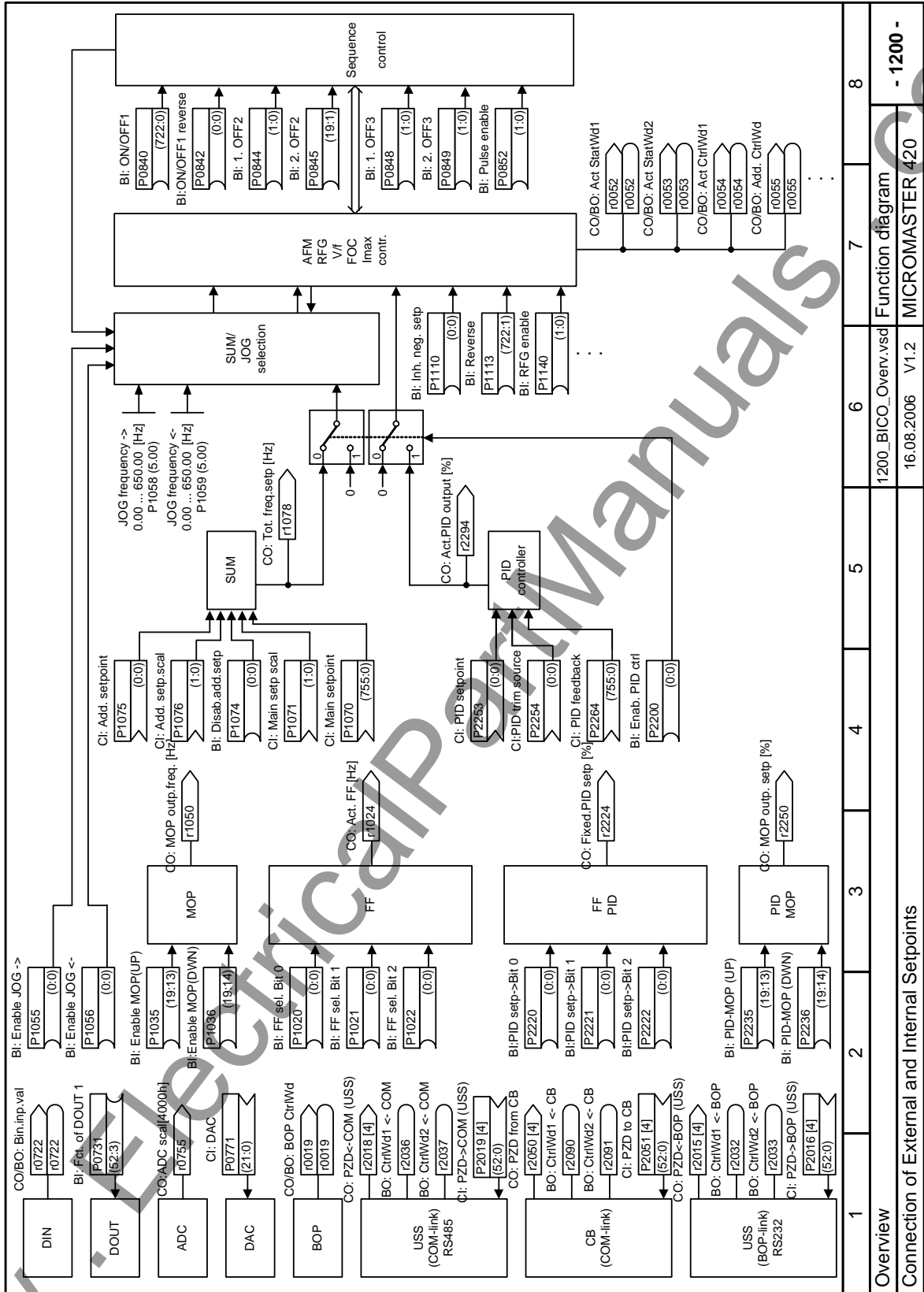

1	2	3	4	5	6	7	8
Overview							
Connection of External and Internal Setpoints							
1200_BICO_Overv.vsd						Function diagram	
16.08.2006 V1.2						MICROMASTER 420	

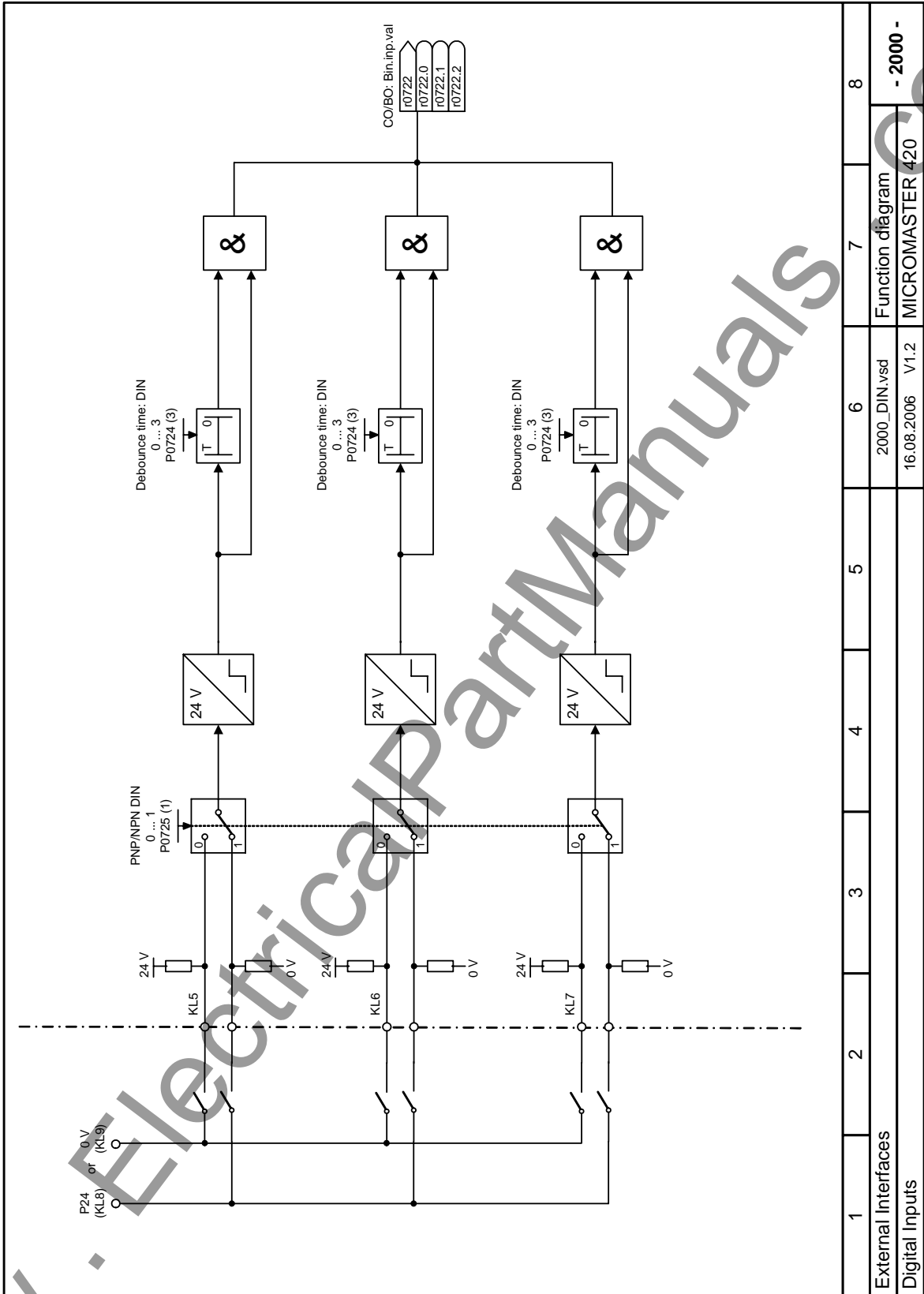

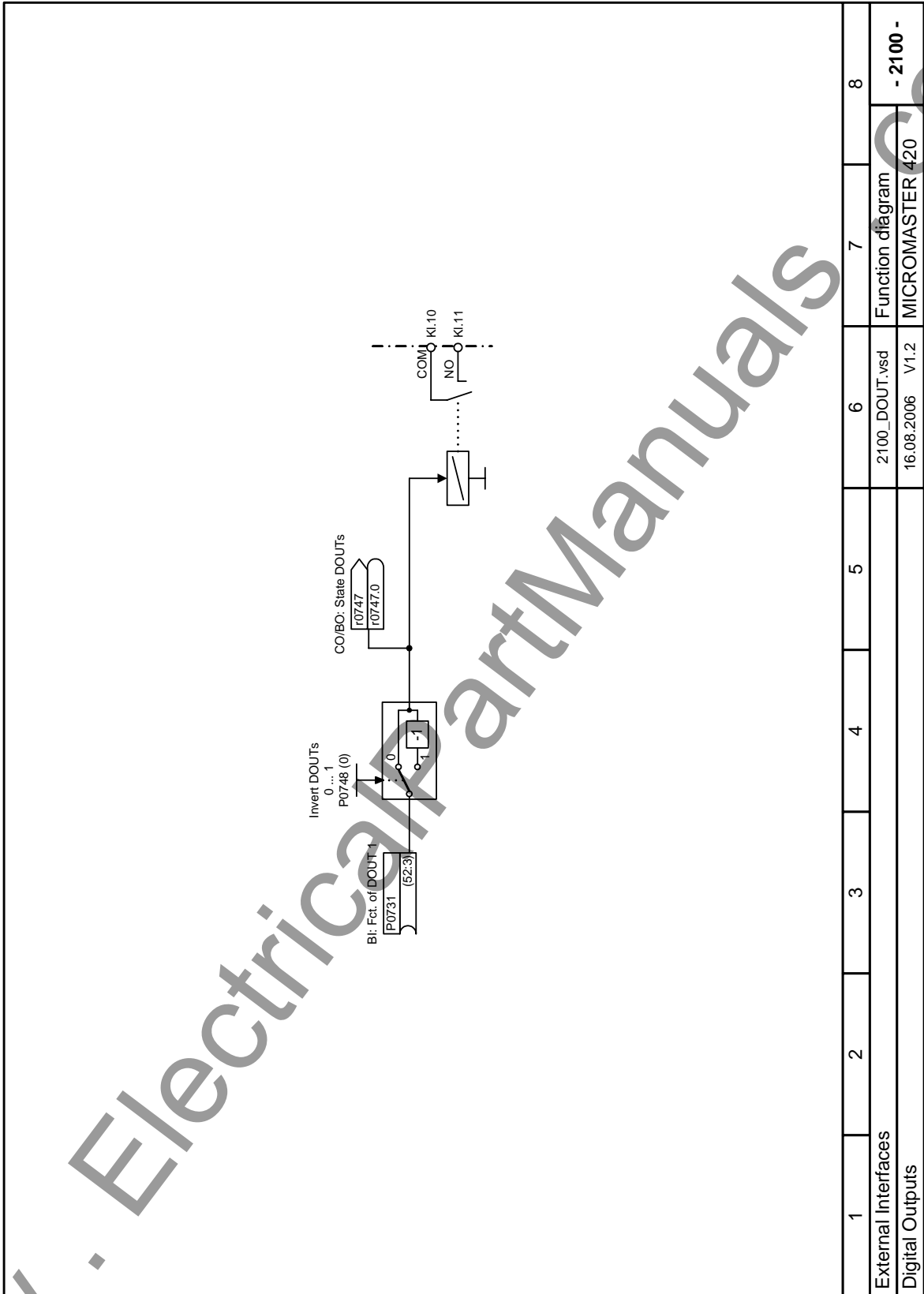

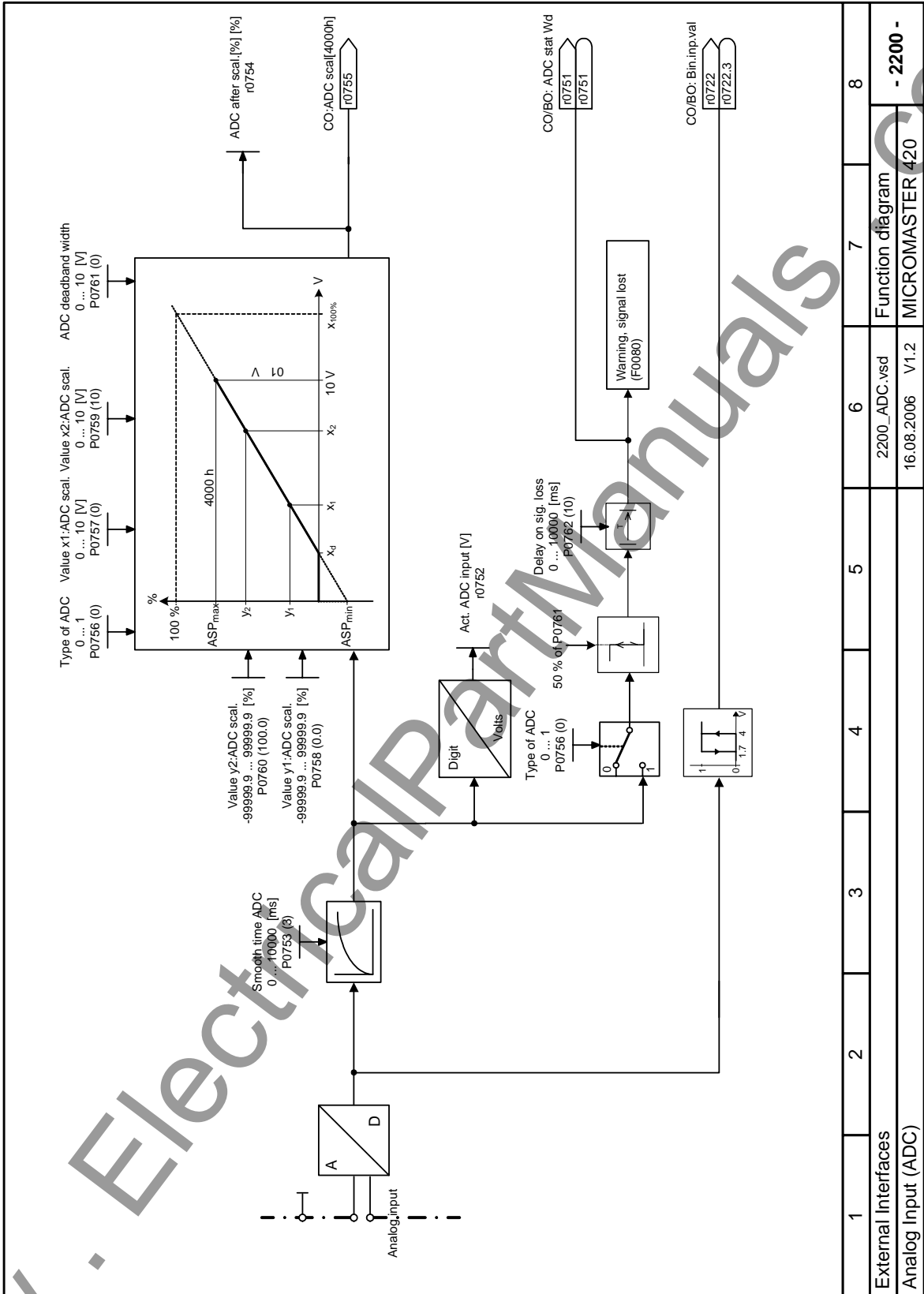

1	2	3	4	5	6	7	8
External Interfaces							
Analog Input (ADC)						Function diagram	- 2200 -
						2200_ADC.vsd	MICROMASTER 420
						16.08.2006	V1.2

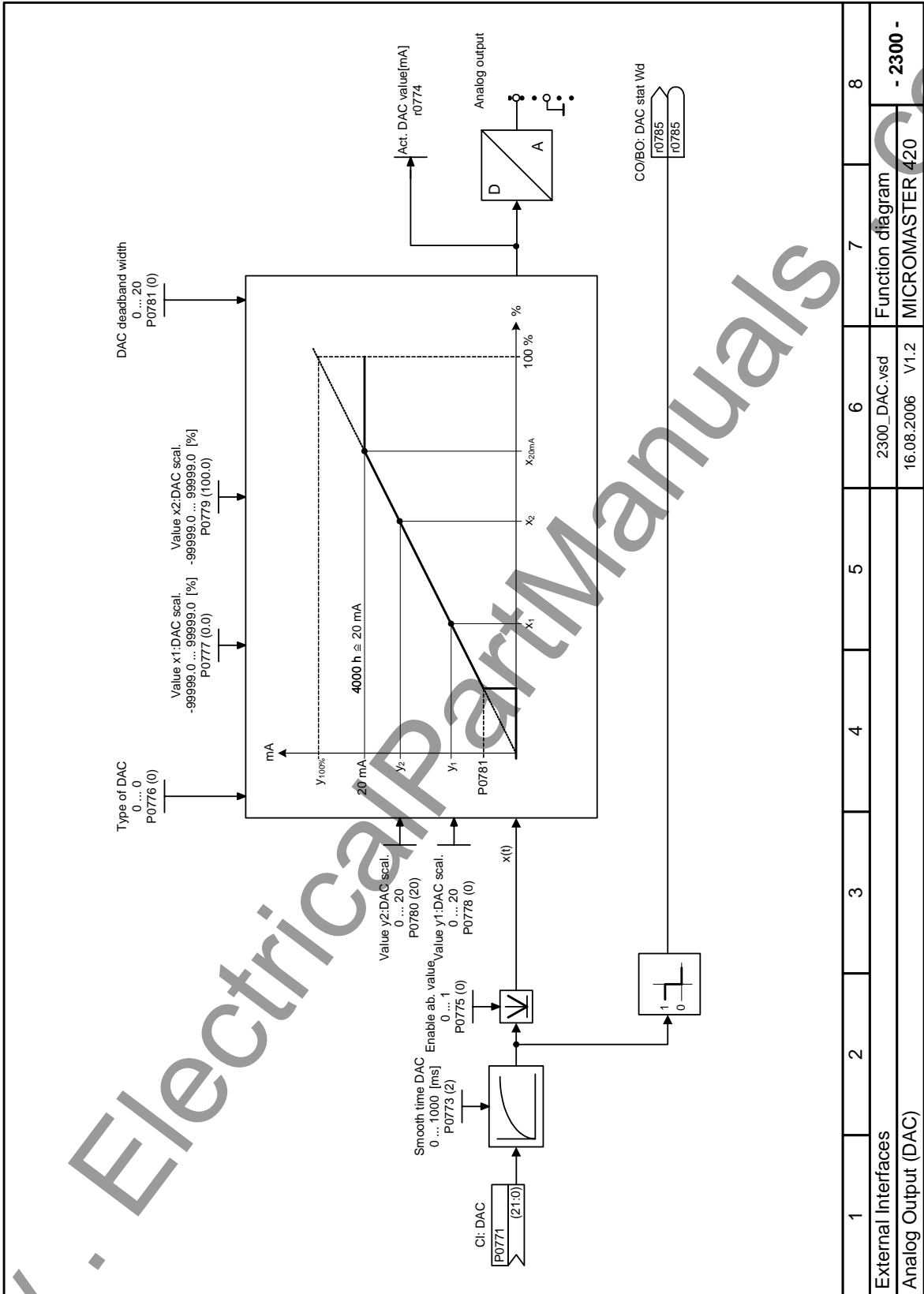

1	2	3	4	5	6	7	8
External Interfaces							
Analog Output (DAC)						Function diagram	- 2300 -
						2300_DAC.vsd	MICROMASTER 420
						16.08.2006	V1.2

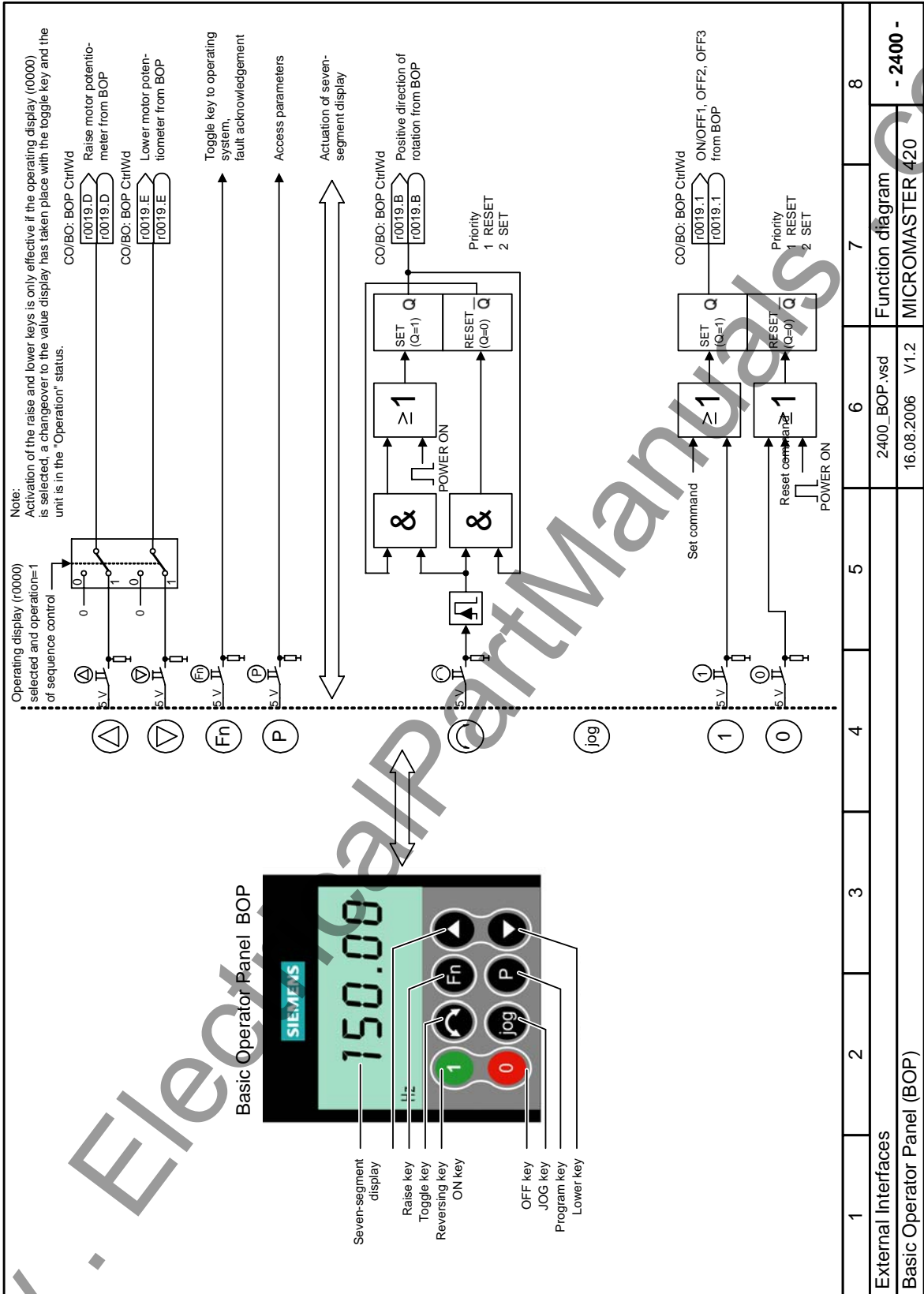

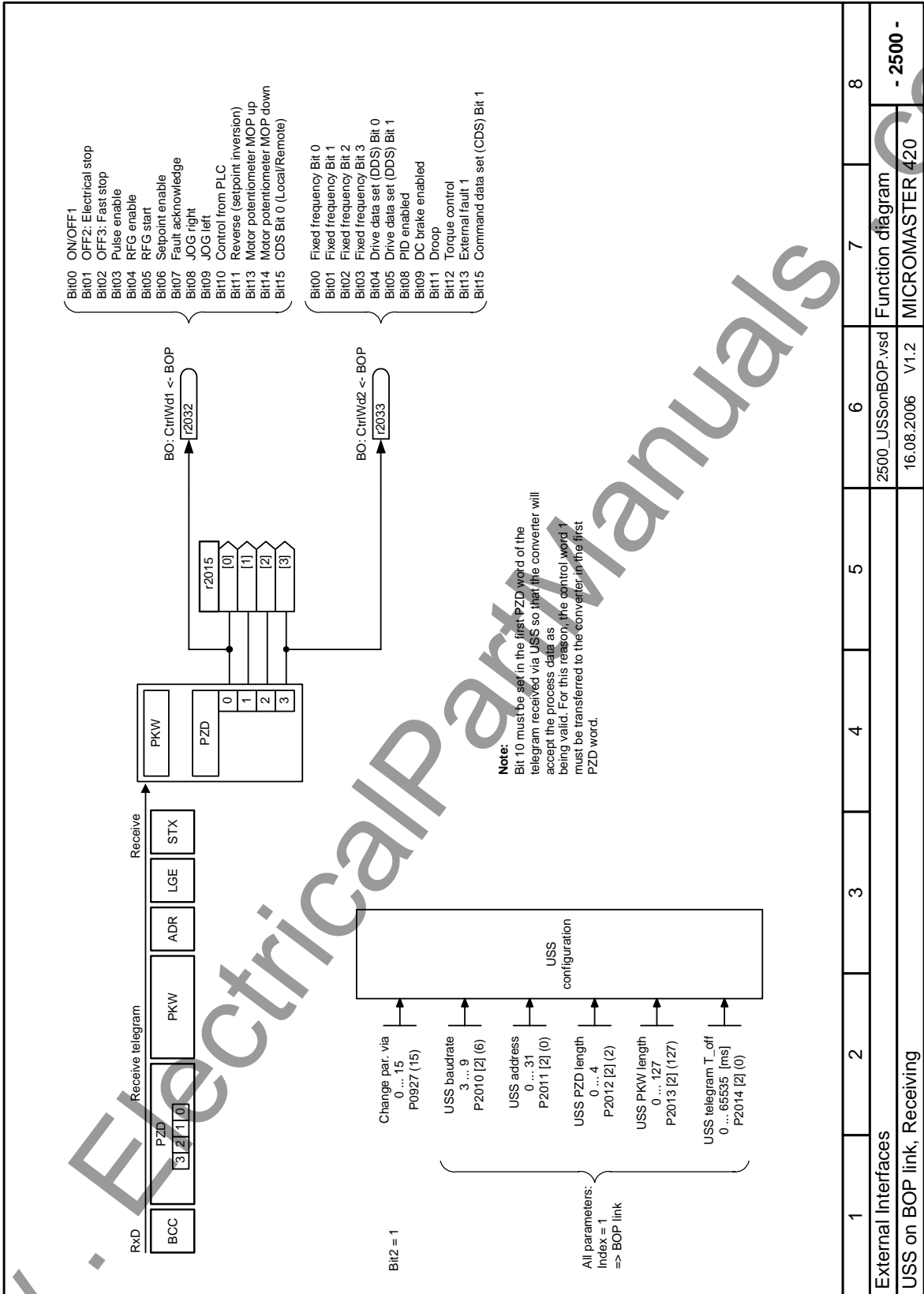

1	2	3	4	5	6	7	8
External Interfaces							
USS on BOP link, Receiving						2500_USSonBOP.vsd	Function diagram
						16.08.2006 V1.2	MICROMASTER 420 - 2500 -

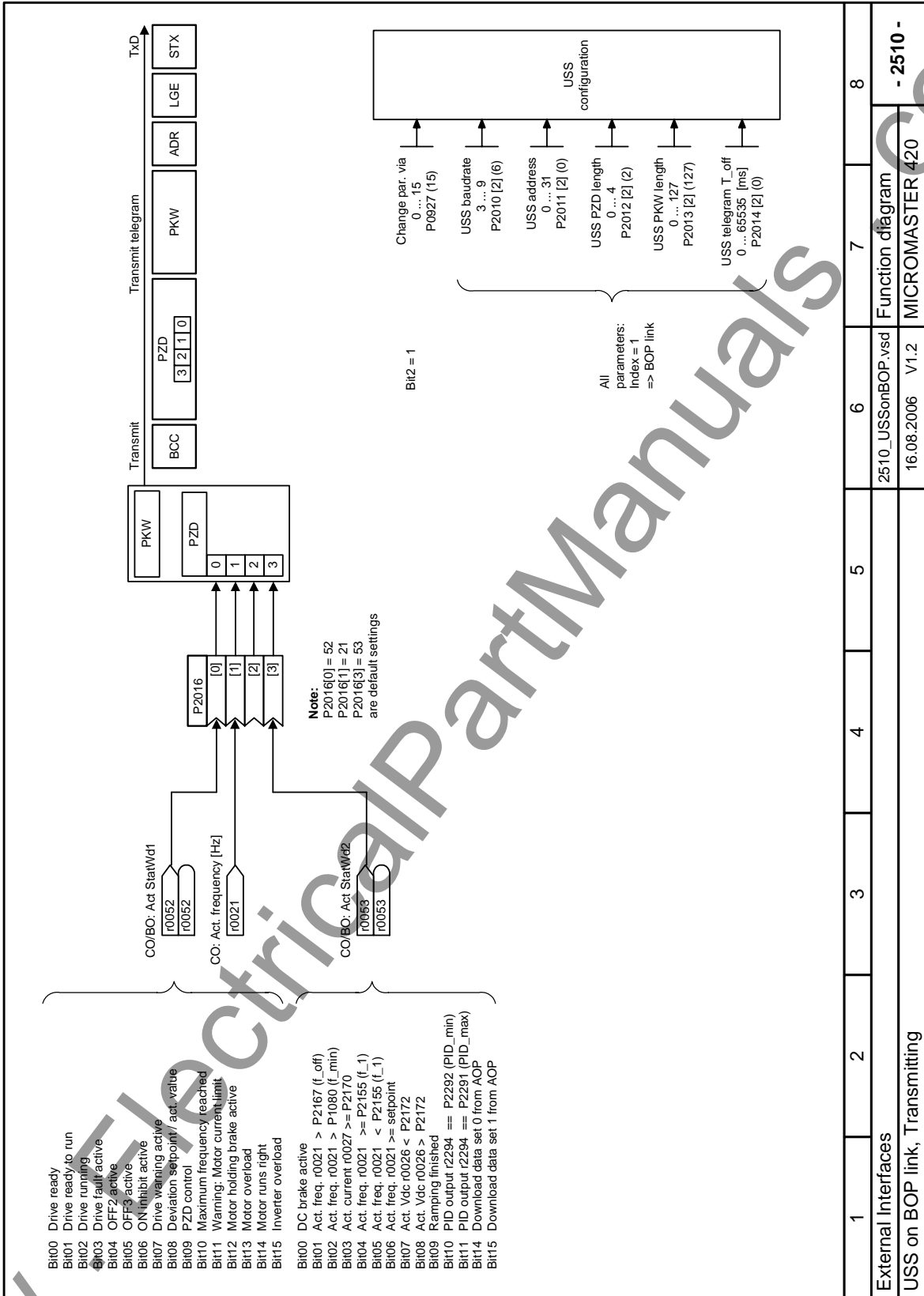

1	2	3	4	5	6	7	8
External Interfaces							
2510_USSonBOP.vsd						Function diagram	
16.08.2006 V1.2						MICROMASTER 420	
<b>- 2510 -</b>							

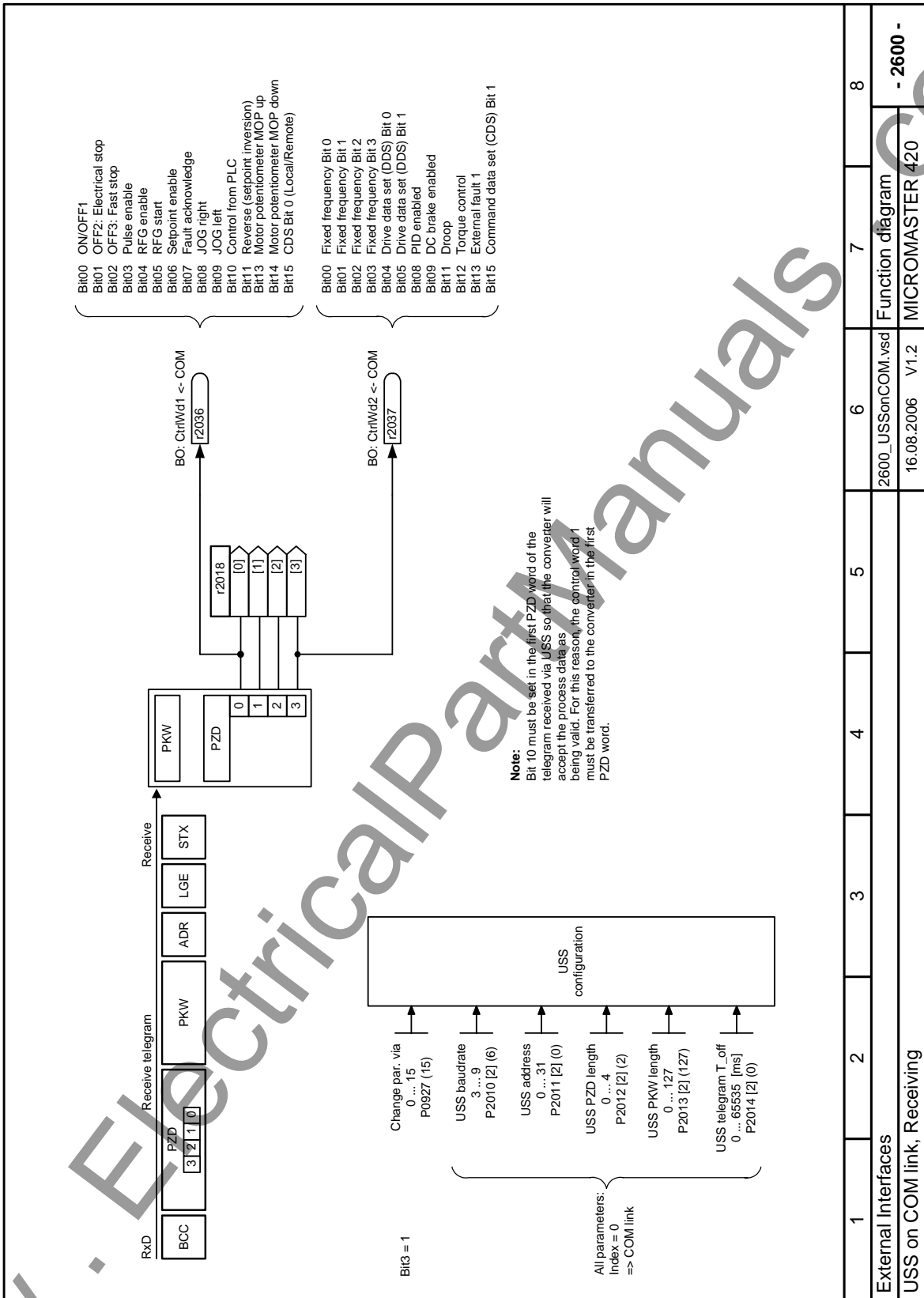

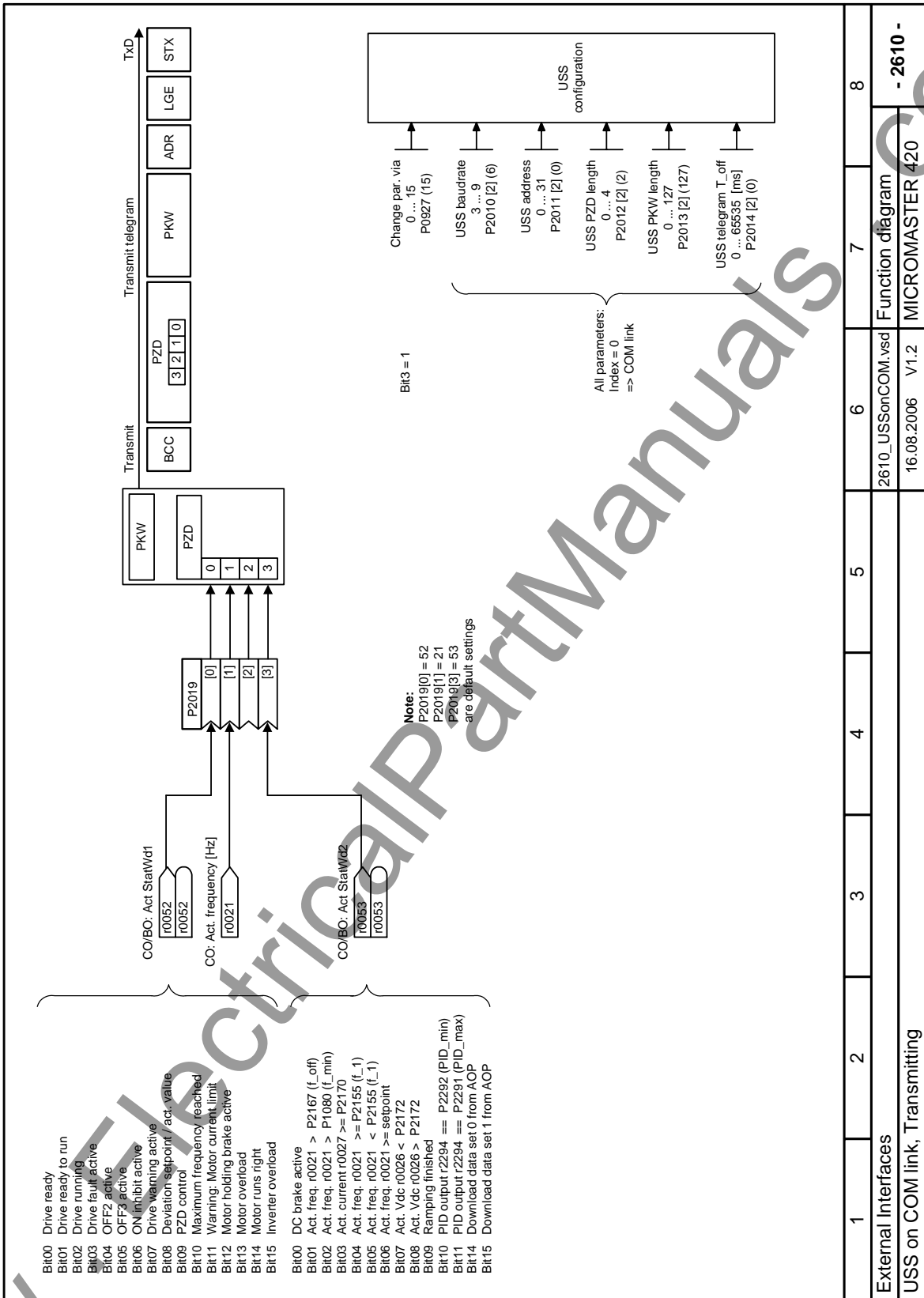

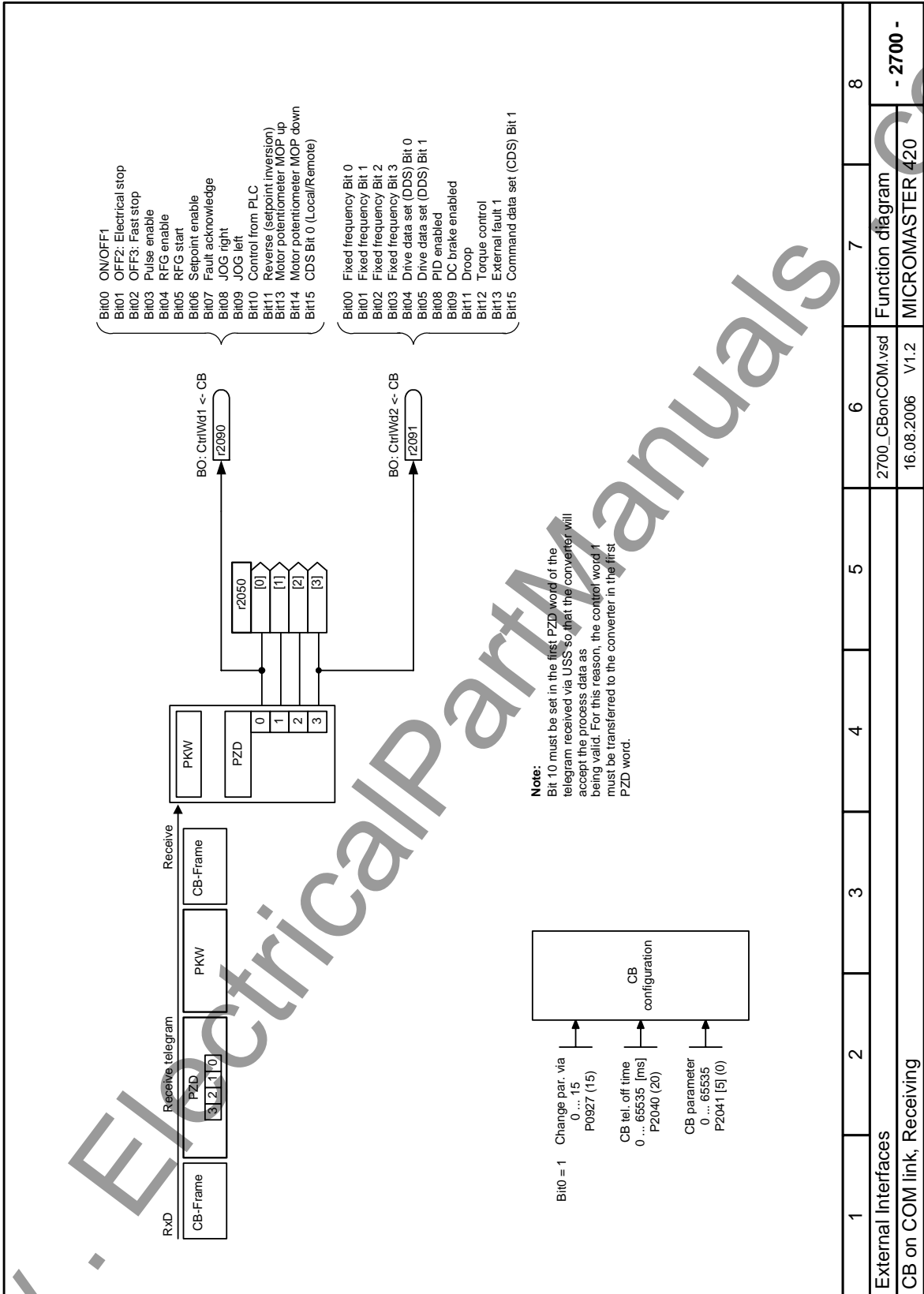

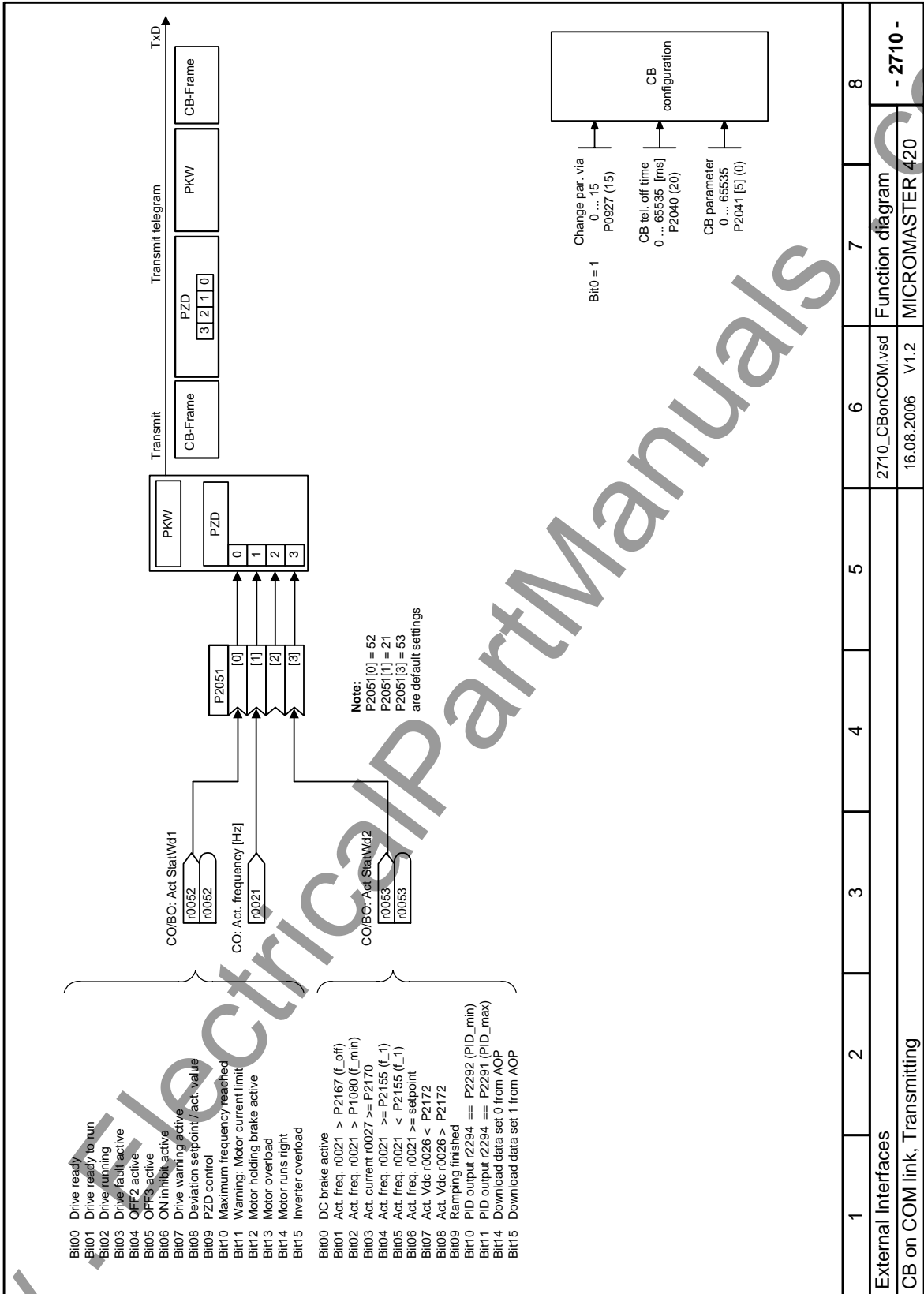

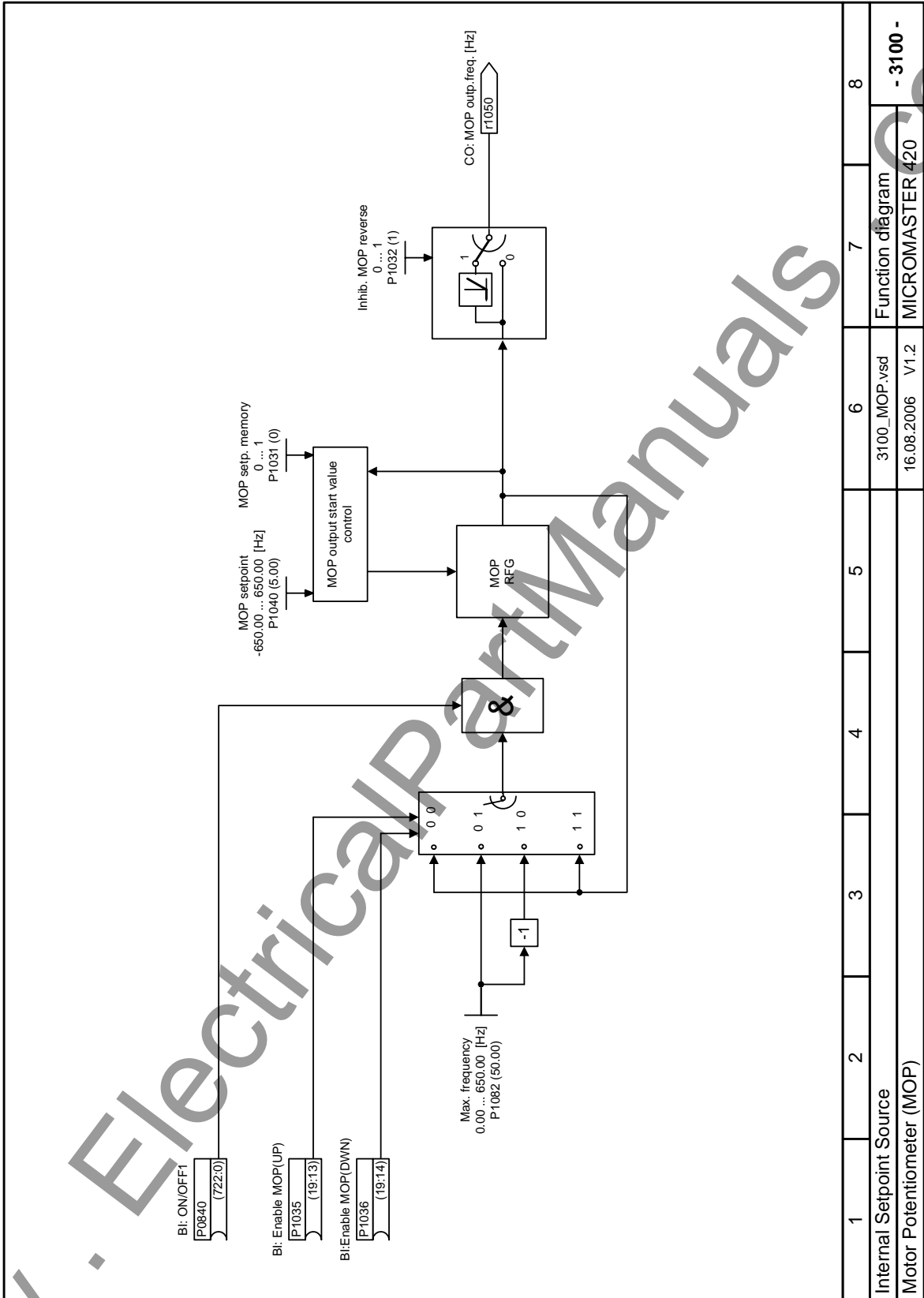

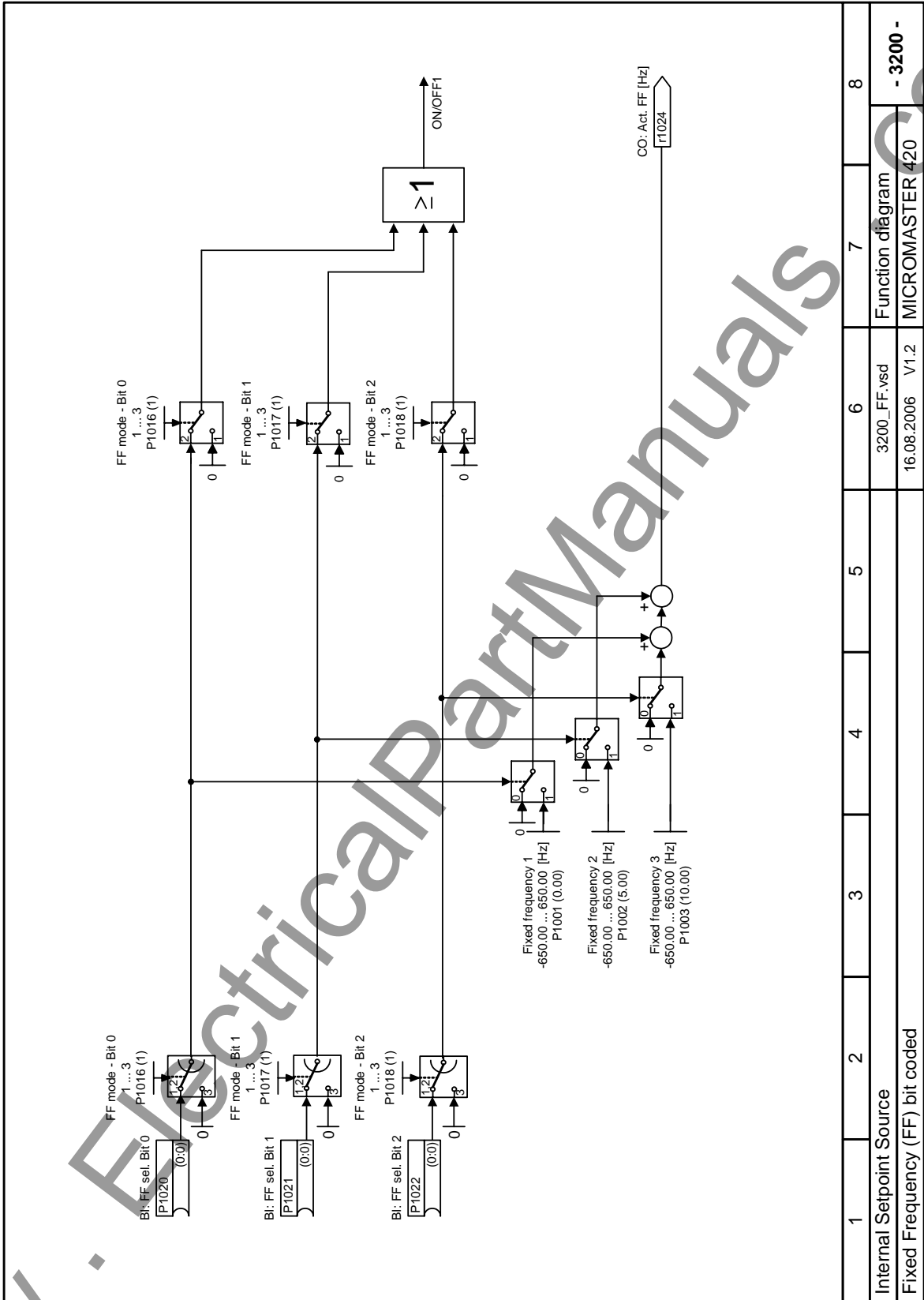

1	2	3	4	5	6	7	8
Internal Setpoint Source							
3200_FF.vsd						Function diagram	
16.08.2006 V1.2						MICROMASTER 420	
- 3200 -							

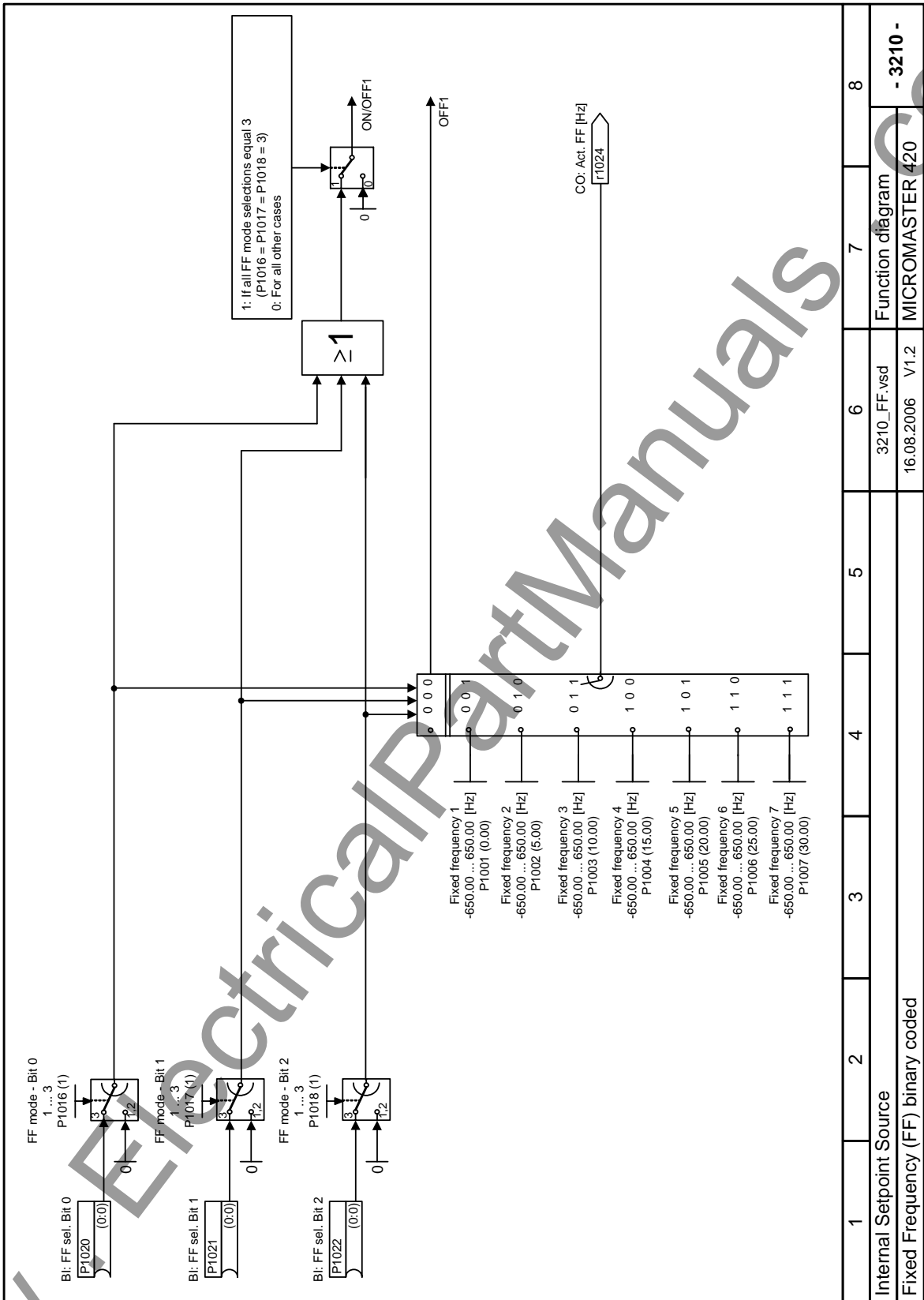

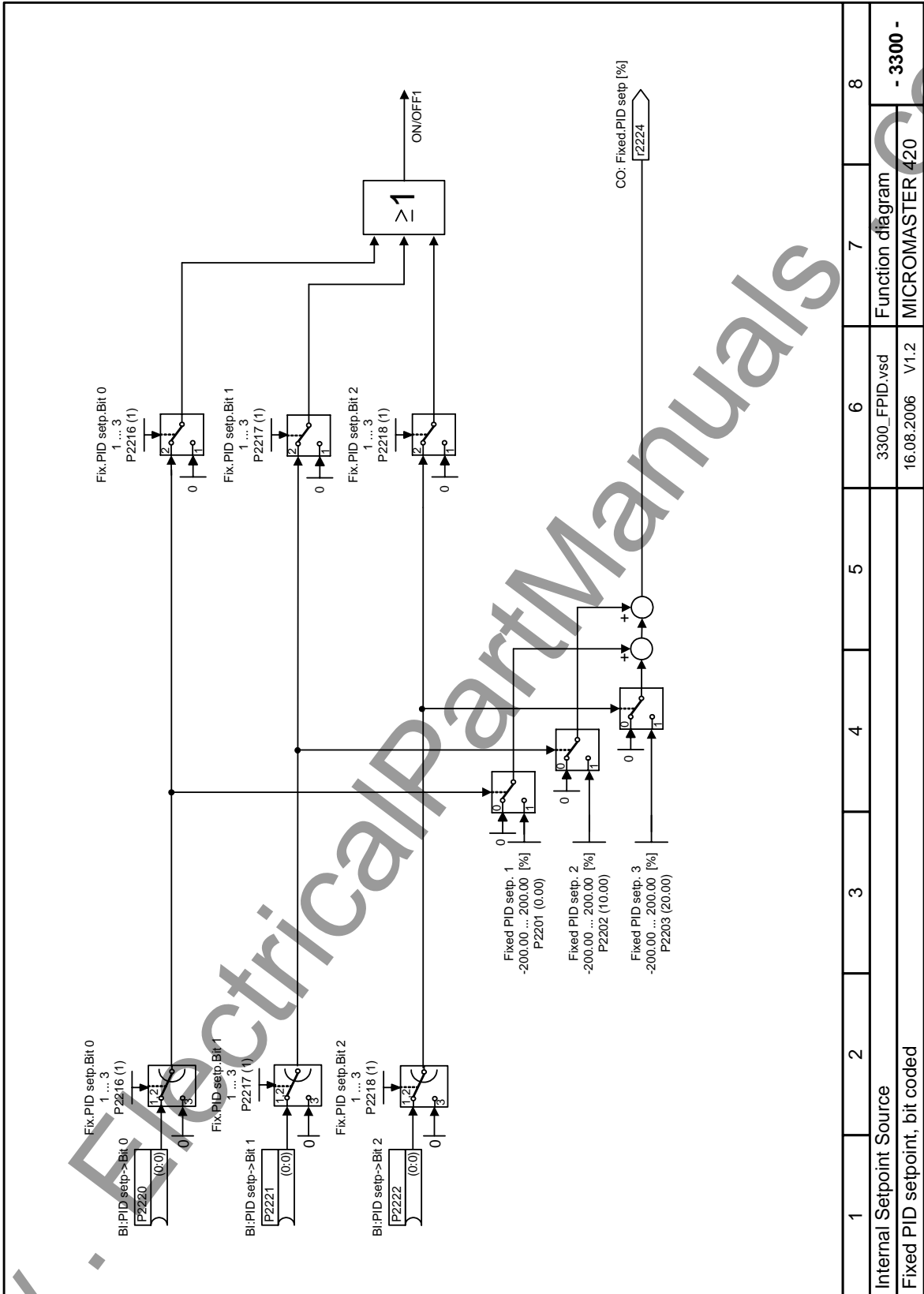

1	2	3	4	5	6	7	8
Internal Setpoint Source							
3300_FPID.vsd						Function diagram	
16.08.2006 V1.2						MICROMASTER 420	
Fixed PID setpoint, bit coded - 3300 -							

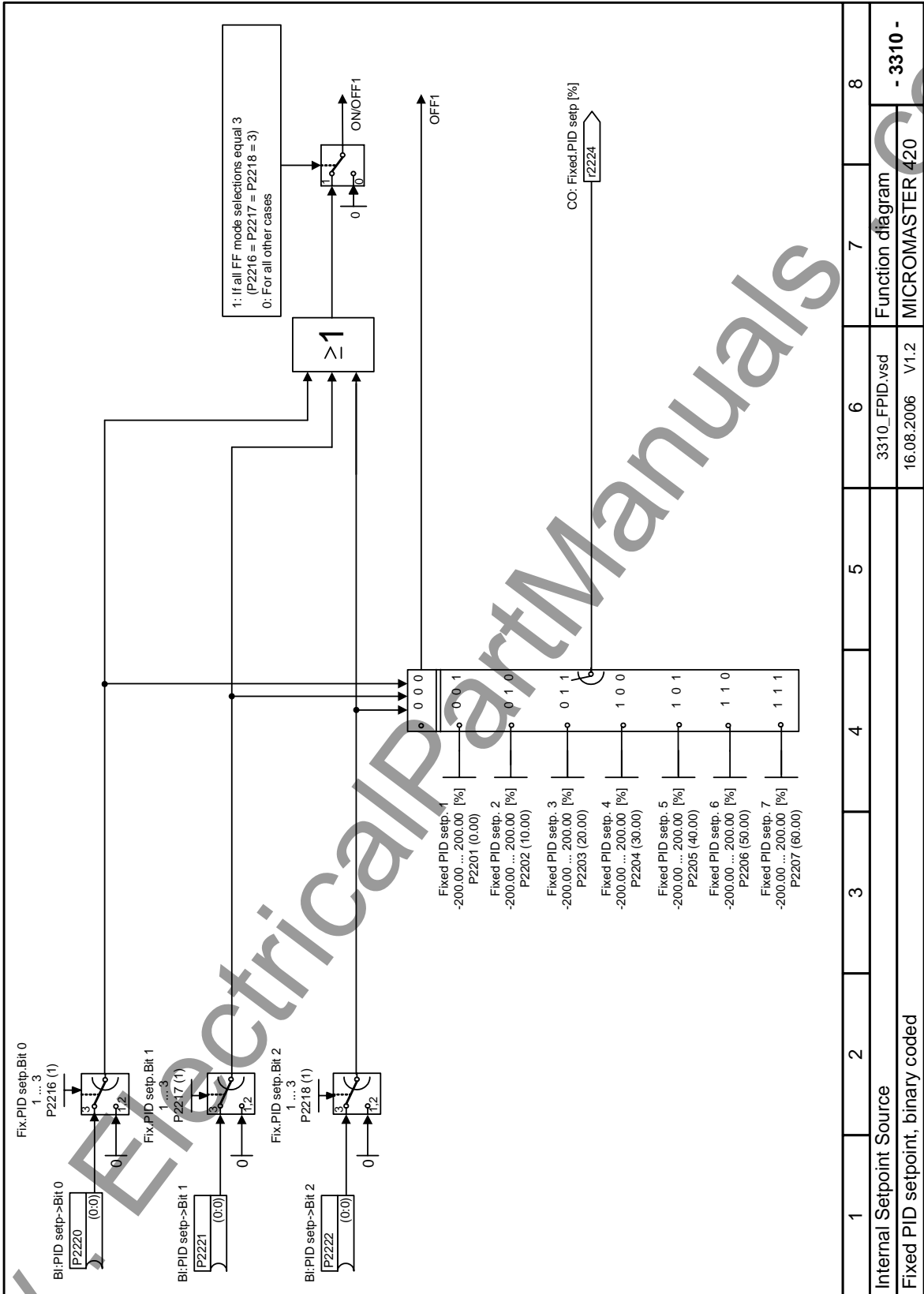

1	2	3	4	5	6	7	8
Internal Setpoint Source						Function diagram	
Fixed PID setpoint, binary coded						MICROMASTER 420	
3310_FPID.vsd						- 3310 -	
16.08.2006 V1.2							

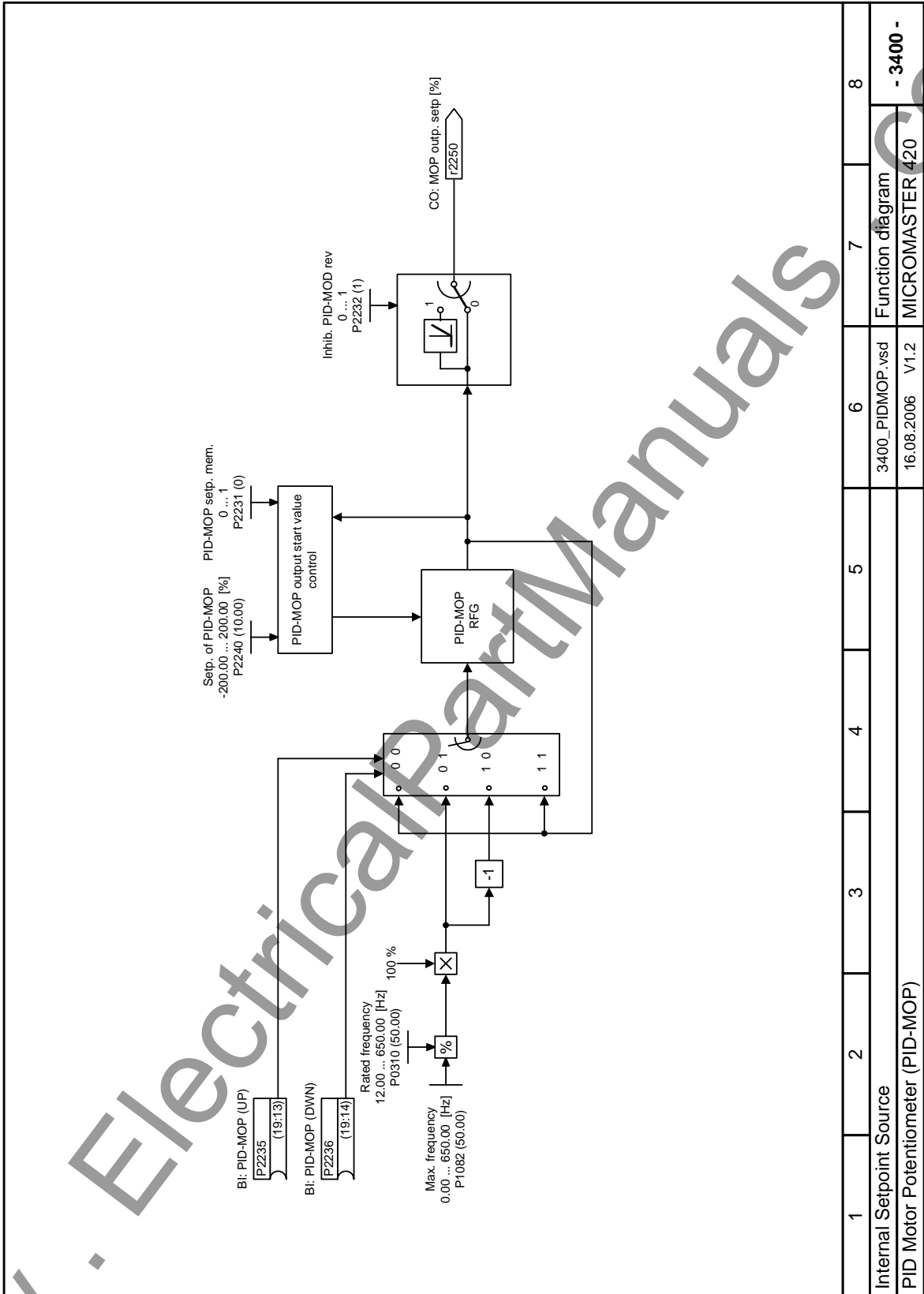

1	2	3	4	5	6	7	8
Internal Setpoint Source							
PID Motor Potentiometer (PID-MOP)							
3400_PIDMOP.vsd					Function diagram		- 3400 -
16.08.2006					V1.2		MICROMASTER 420

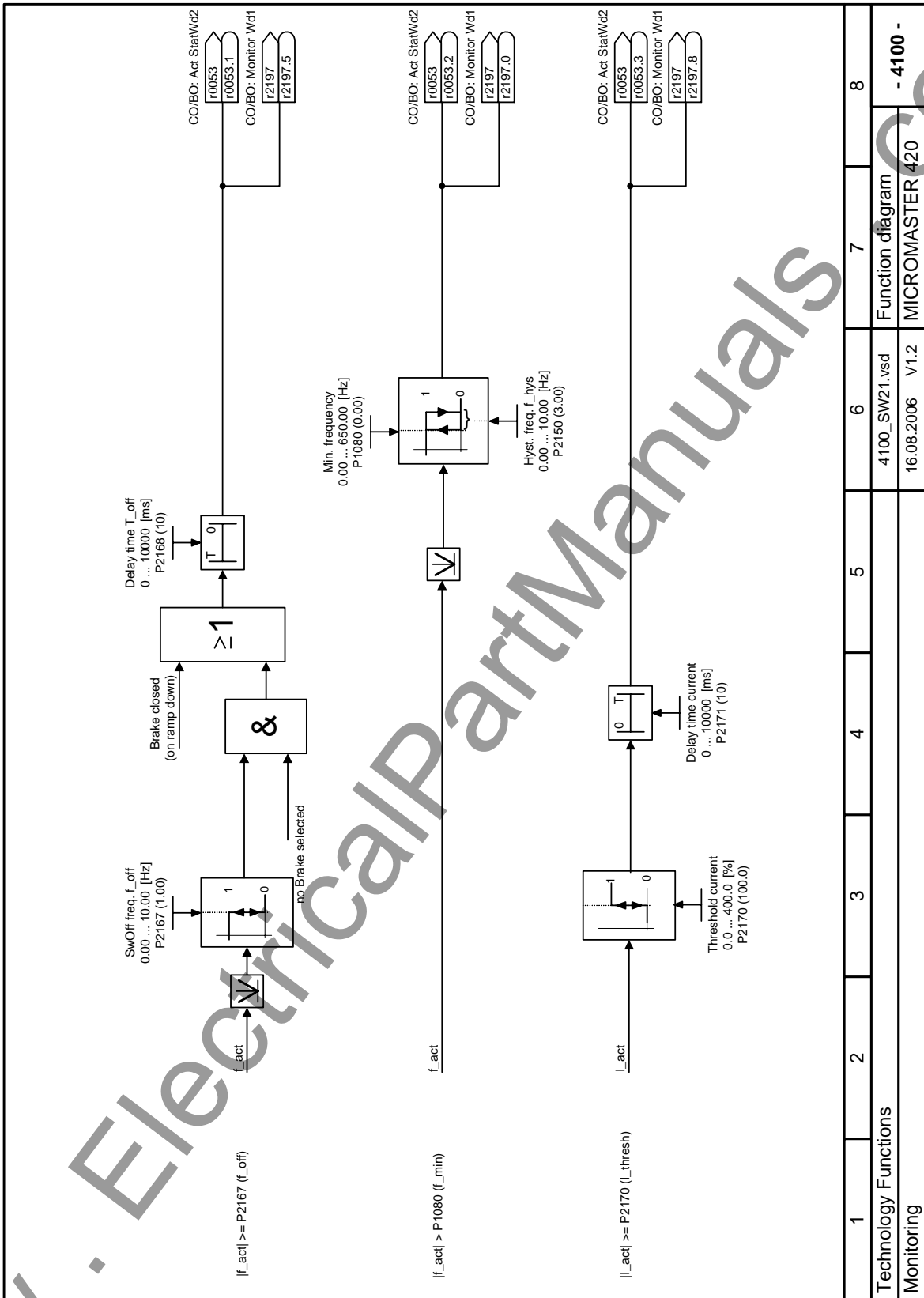

1	2	3	4	5	6	7	8
Technology Functions							
Monitoring							
				4100_SW21.vsd		Function diagram	
				16.08.2006 V1.2		MICROMASTER 420	
						- 4100 -	

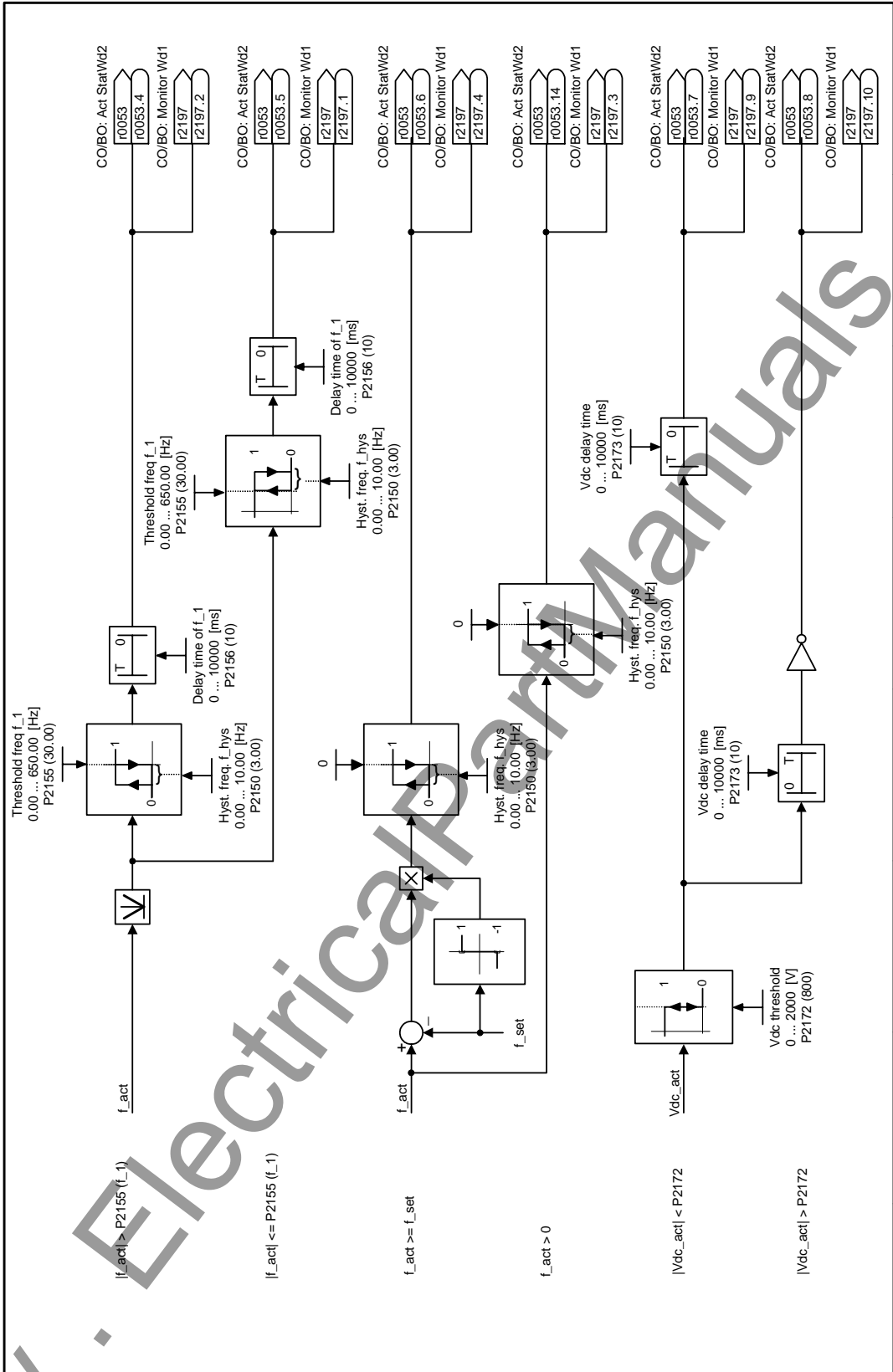

1	2	3	4	5	6	7	8
Technology Functions							
Monitoring							
4110_SW22.vsd						Function diagram	
16.08.2006 V1.2						MICROMASTER 420	
						- 4110 -	



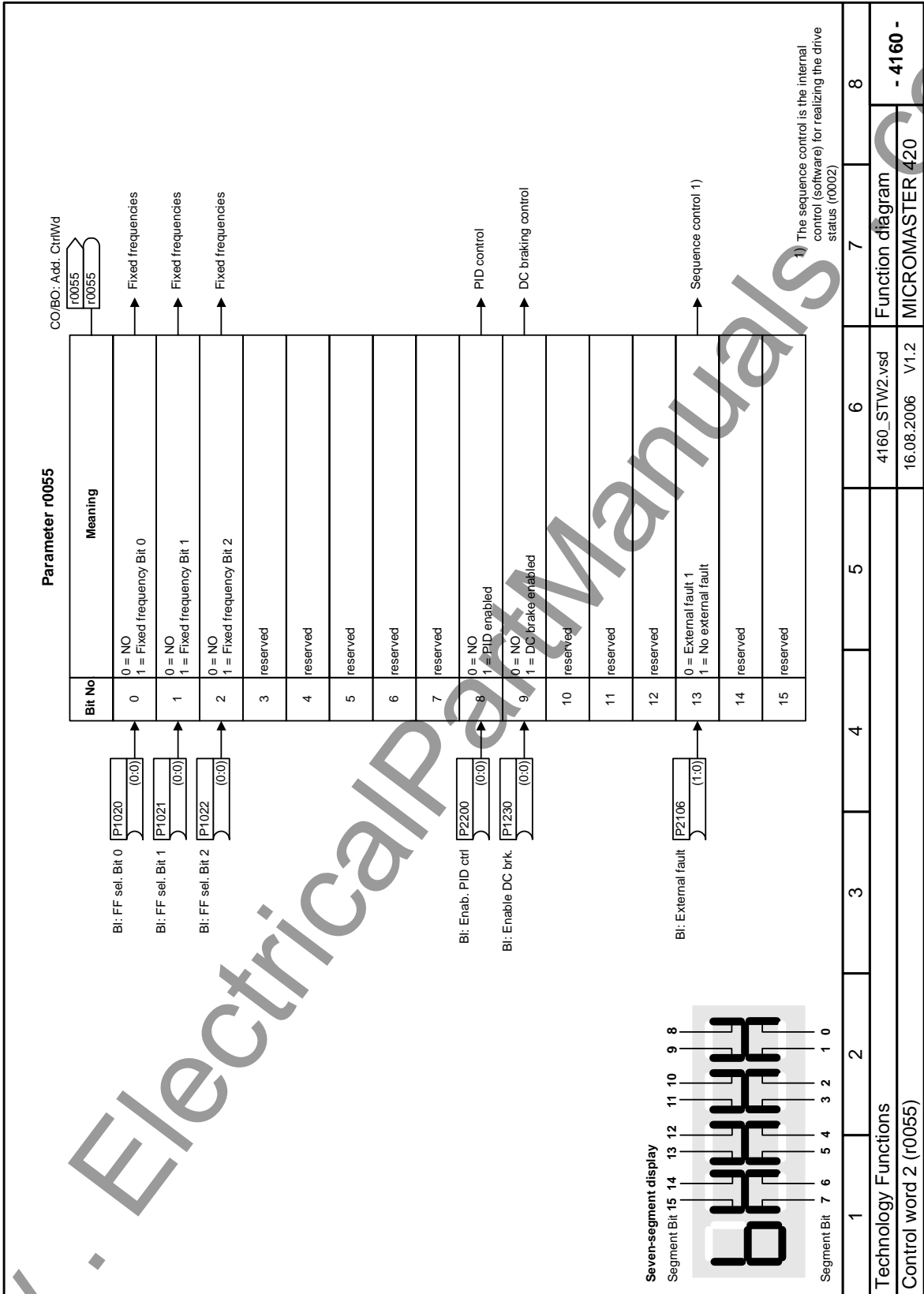

Parameter r0052		COBO: Act StatWd1	
Bit No.	Meaning	r0052	r0052
0	1 = Drive ready 0 = Drive not ready		
1	1 = Drive ready to run (DC link loaded, pulses disabled) 0 = Drive not ready to run		
2	1 = Drive running (voltage at output terminals) 0 = Pulses disabled		
3	1 = Drive fault active (pulses disabled) 0 = No fault	r0052	r0052.03
4	0 = OFF3 active 1 = No OFF3		
5	0 = OFF3 active 1 = No OFF3		
6	1 = ON inhibit active 0 = No On inhibit (possible to switch on)		
7	1 = Drive warning active 0 = No warning		
8	0 = Deviation setpoint / act. value 1 = No deviation setpoint / act. Value		
9	1 = PZD control (always 1)		
10	1 = Maximum frequency reached 0 = Maximum frequency not reached		
11	0 = Warning: Motor current limit 1 = Motor current limit not reached		
12	1 = Motor holding brake active 0 = Motor holding brake not active		
13	0 = Motor overload 1 = No Motor overload		
14	1 = Motor runs right 0 = Motor does not run right		
15	0 = Inverter overload 1 = No inverter overload		

1	2	3	4	5	6	7	8
Technology Functions							
4170_ZSW1.vsd						Function diagram	
16.08.2006 V1.2						MICROMASTER 420	
						- 4170 -	

Signal "Fault active" is inverted by MICROMASTER, if connected to a digital output which means that the relay will be in the de-energised state.

Seven-segment display  
Segment Bit 15 14 13 12 11 10 9 8  
Segment Bit 7 6 5 4 3 2 1 0

**0111111**

<sup>1)</sup> The sequence control is the internal control (software) for realizing the drive status (r0002)

Parameter r0053		CO/BO: Act StatWz2
Bit No.	Meaning	
0	1 = DC brake active 0 = DC brake not active	
1	1 = f_act > P2167 (f_off)	
2	1 = f_act >= P1080 (f_min)	
3	1 = Act. current r0027 >= P2170	
4	1 = f_act > P2155 (f_1)	
5	1 = f_act <= P2155 (f_1)	
6	1 = f_act >= setpoint	
7	1 = Act. Vdc r0026 < P2172	
8	1 = Act. Vdc r0026 > P2172	
9	1 = Ramping finished	
10	1 = PID output r2294 == P2292 (PID_min)	
11	1 = PID output r2294 == P2294 (PID_max)	
12	reserved	
13	reserved	
14	Download data set 0 from AOP	
15	Download data set 1 from AOP	

1	2	3	4	5	6	7	8
Technology Functions							
Status word 2 (r0053)							
4180_ZSW2.vsd						Function diagram	
16.08.2006 V1.2						MICROMASTER 420	
						- 4180 -	

  

Seven-segment display

Segment Bit 15 14 13 12 11 10 9 8

Segment Bit 7 6 5 4 3 2 1 0

1) The sequence control is the internal control (software) for realizing the drive status (r0002)

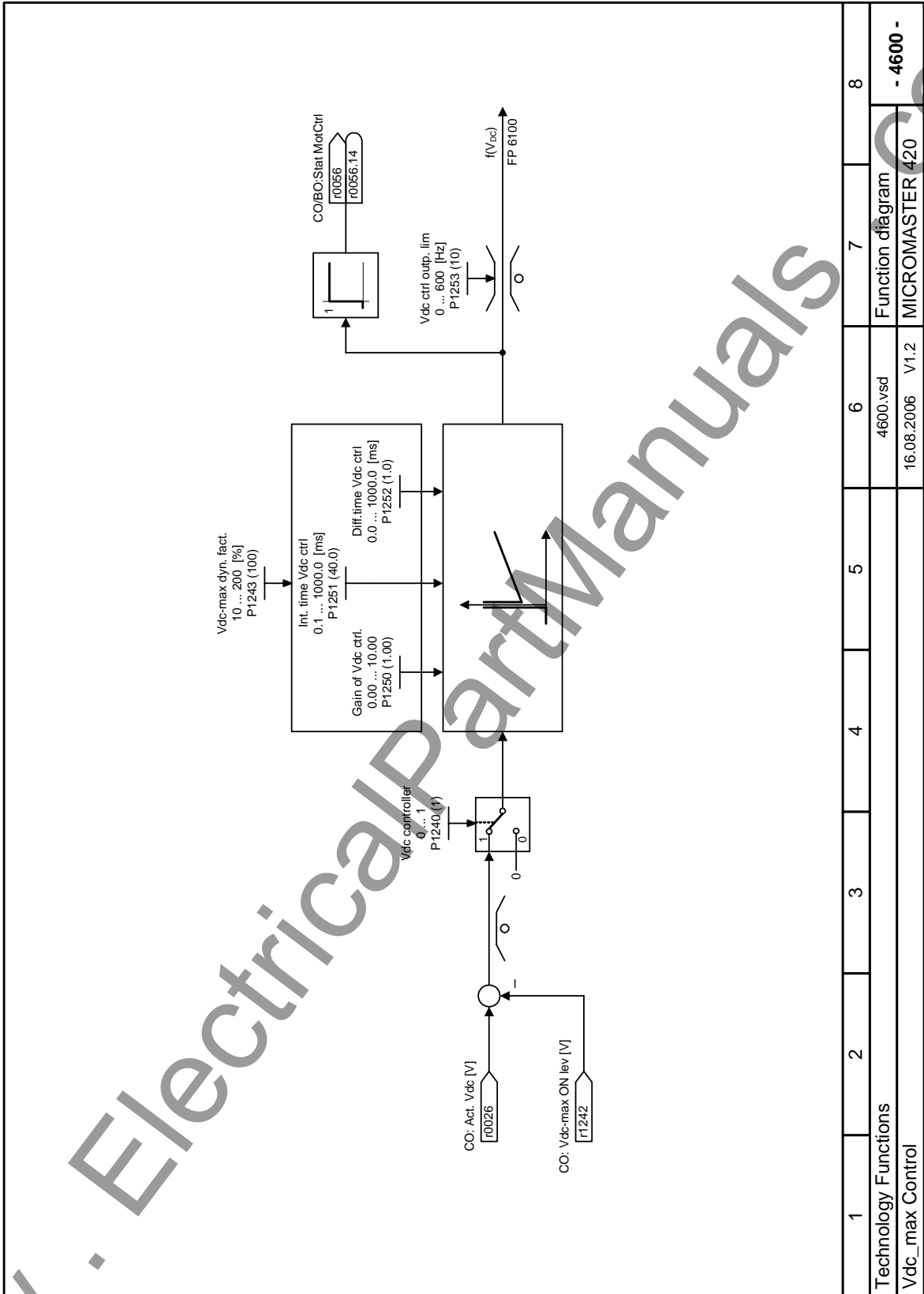

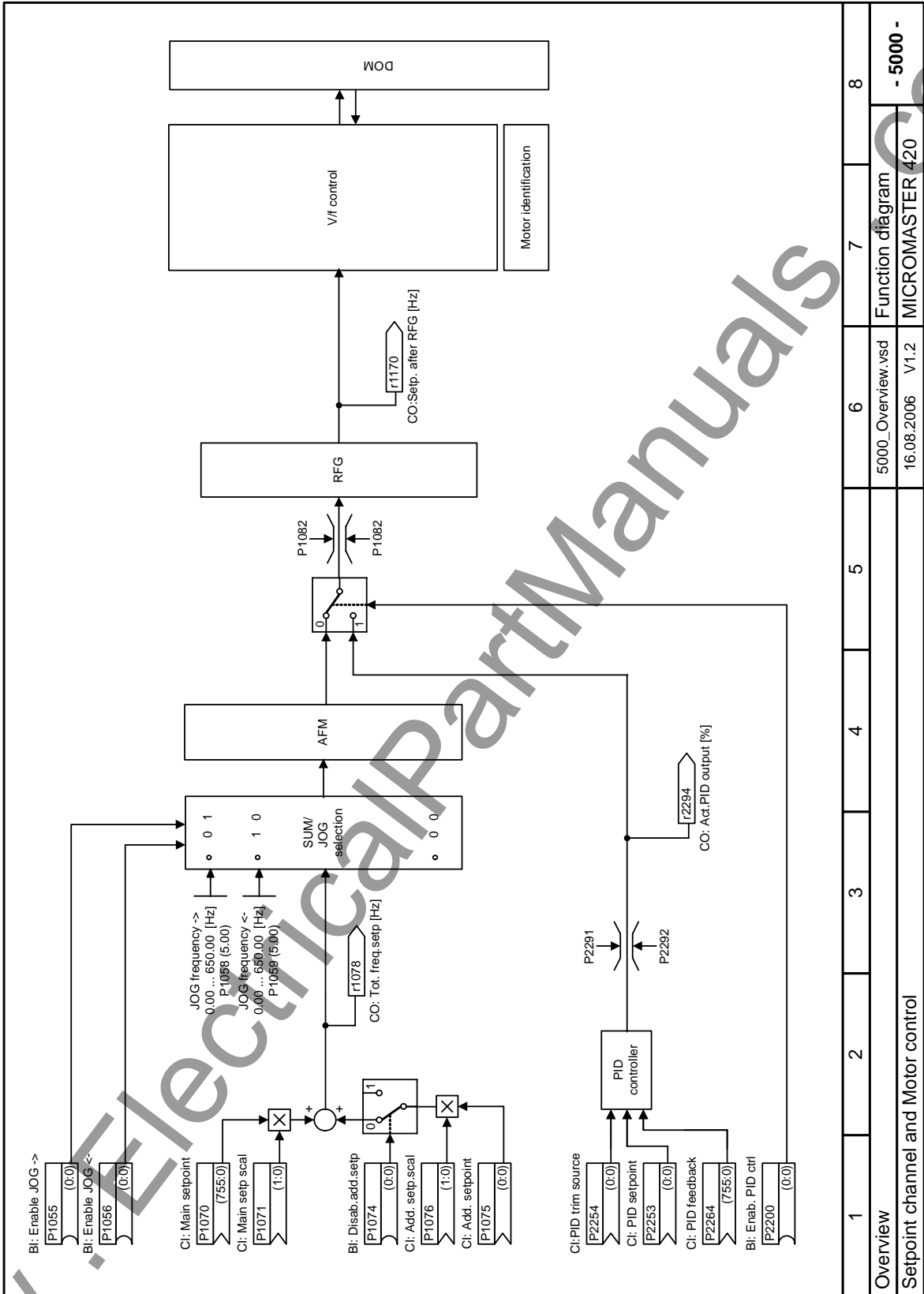

1	2	3	4	5	6	7	8
Overview							
Setpoint channel and Motor control				5000_Overview.vsd 16.08.2006 V1.2		Function diagram MICROMASTER 420	
- 5000 -							

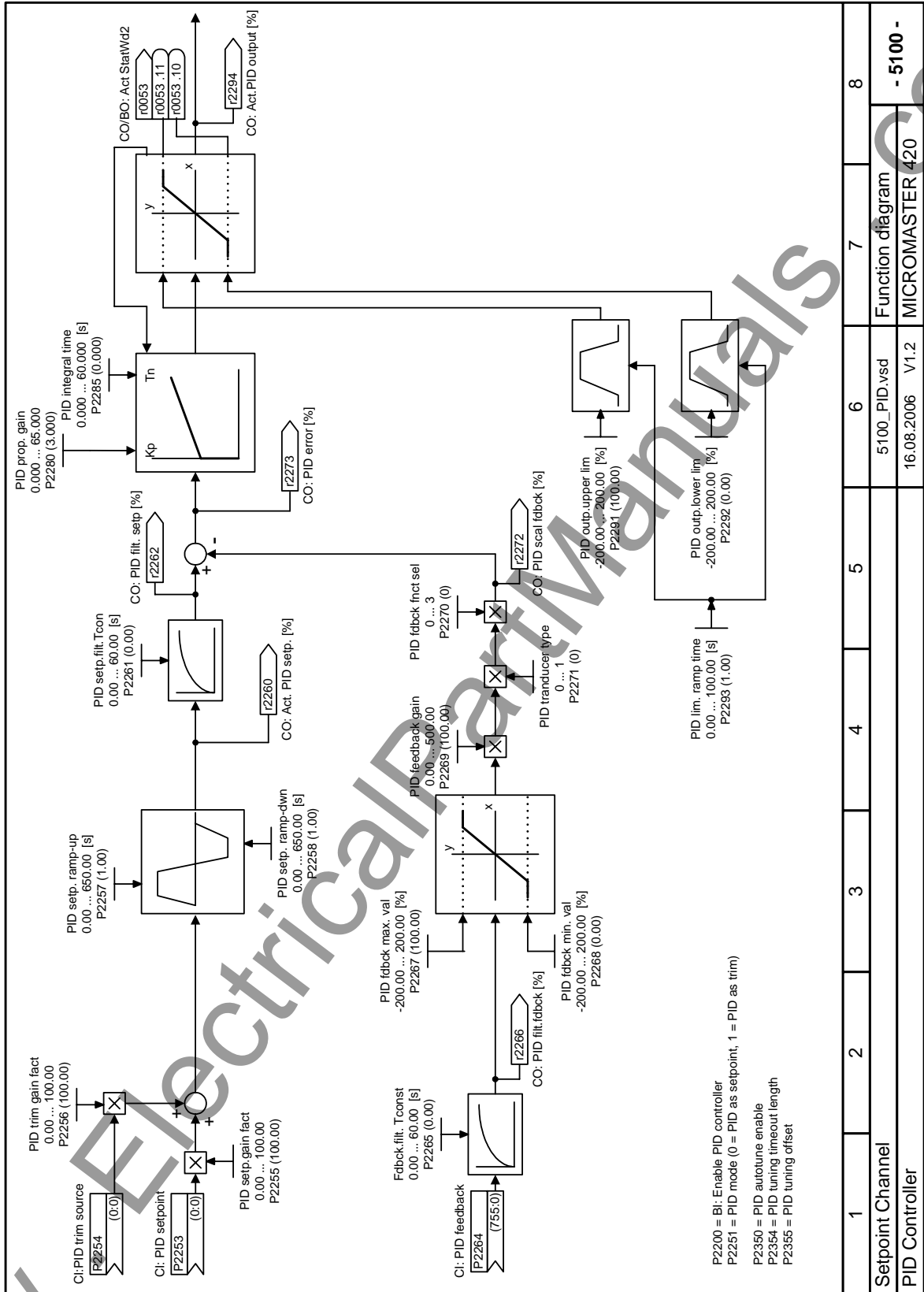

1	2	3	4	5	6	7	8
Setpoint Channel						Function diagram	
PID Controller						5100_PID.vsd	- 5100 -
						16.08.2006	V1.2
						MICROMASTER 420	

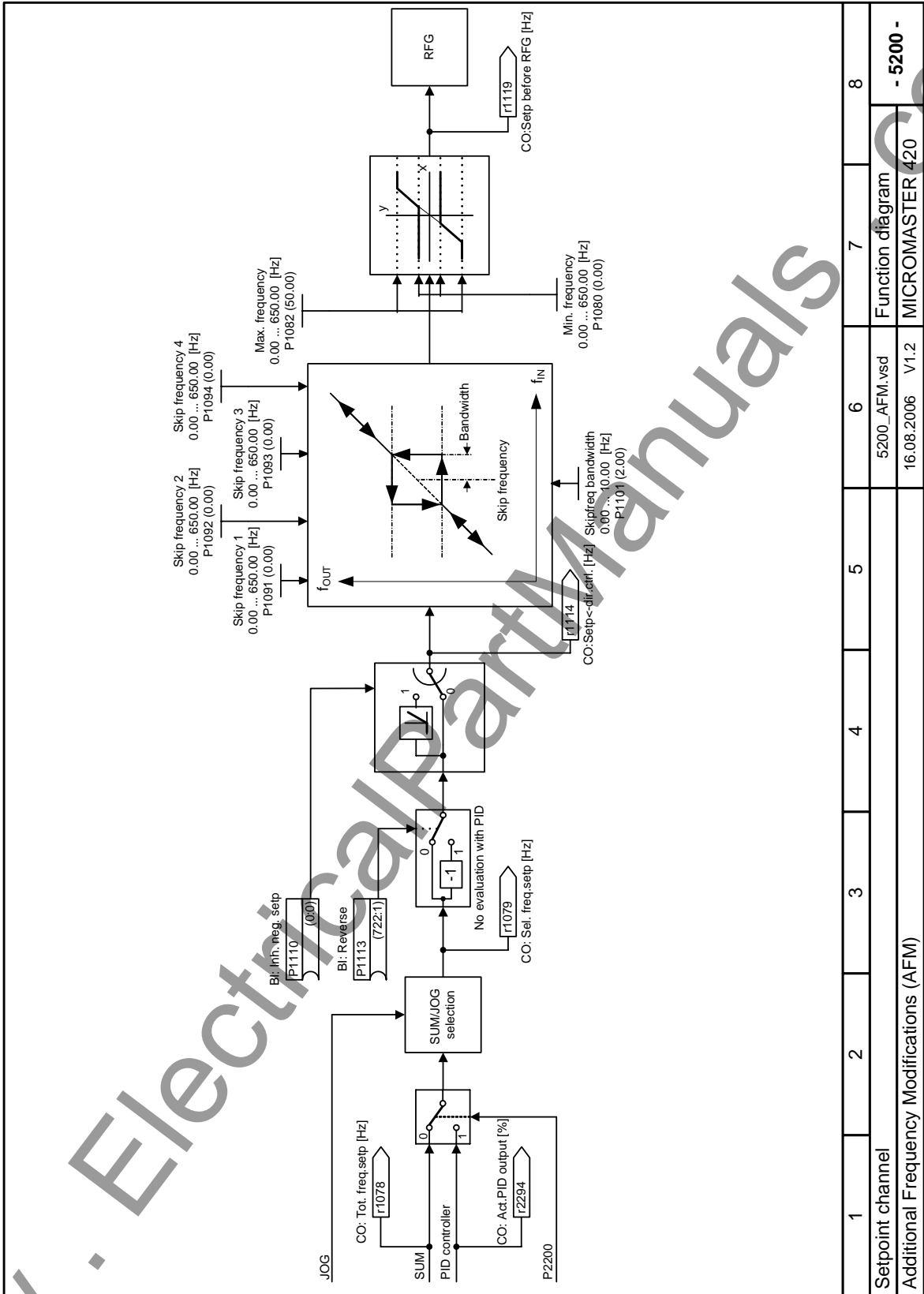

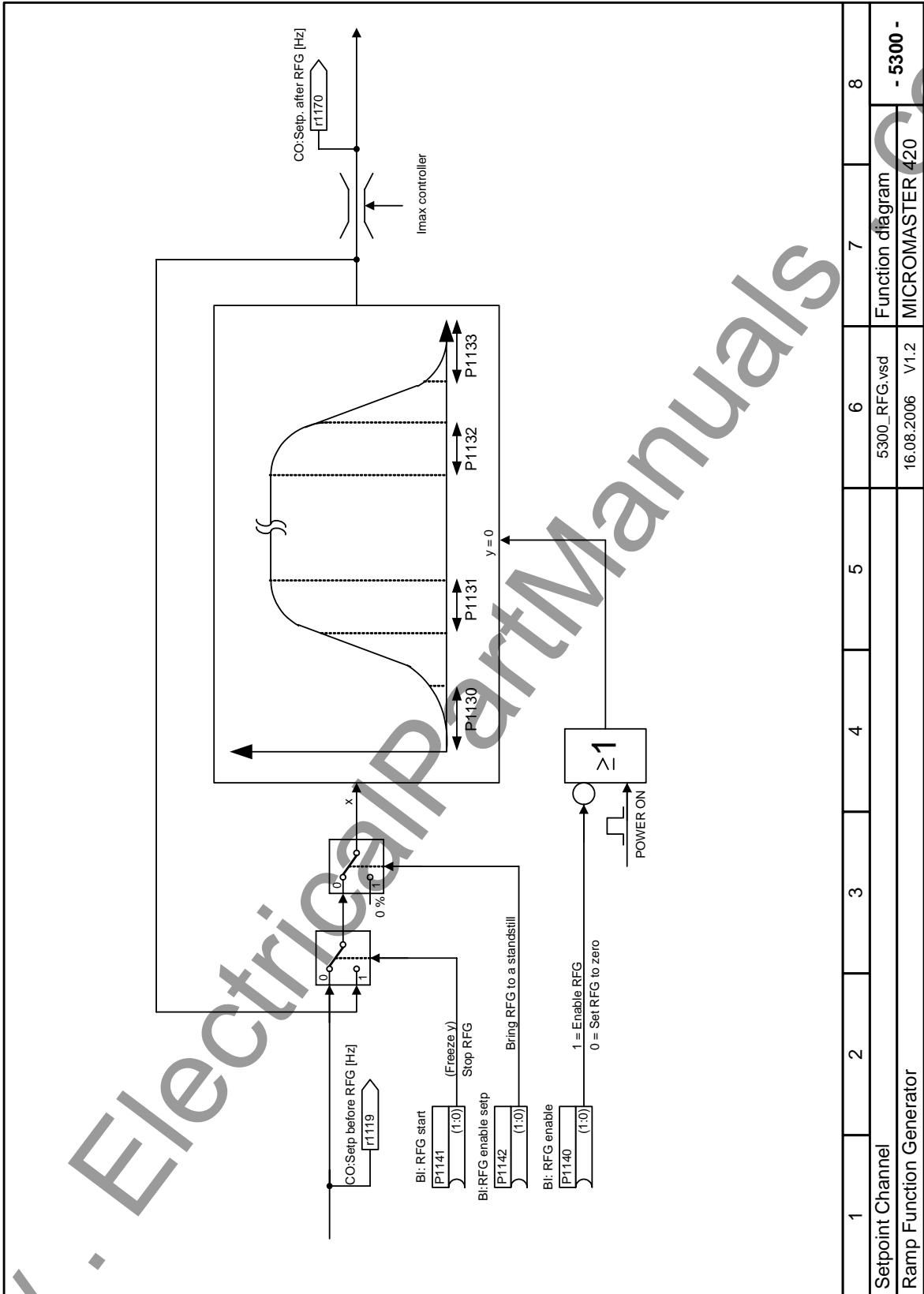

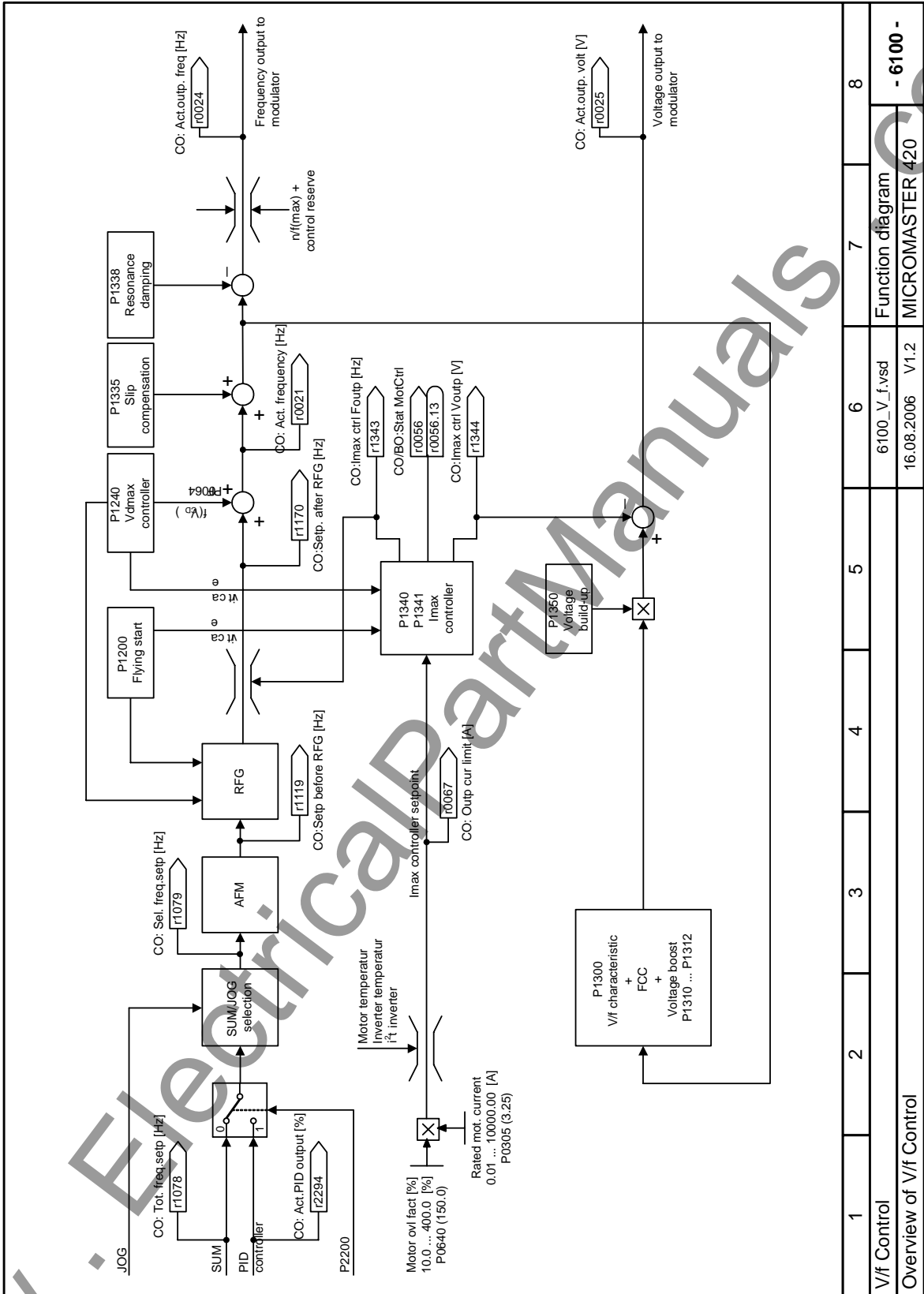

1	2	3	4	5	6	7	8
V/f Control							
Overview of V/f Control							
					6100_V.f.vsd	Function diagram	
					16.08.2006	MICROMASTER 420	
					V1.2	- 6100 -	

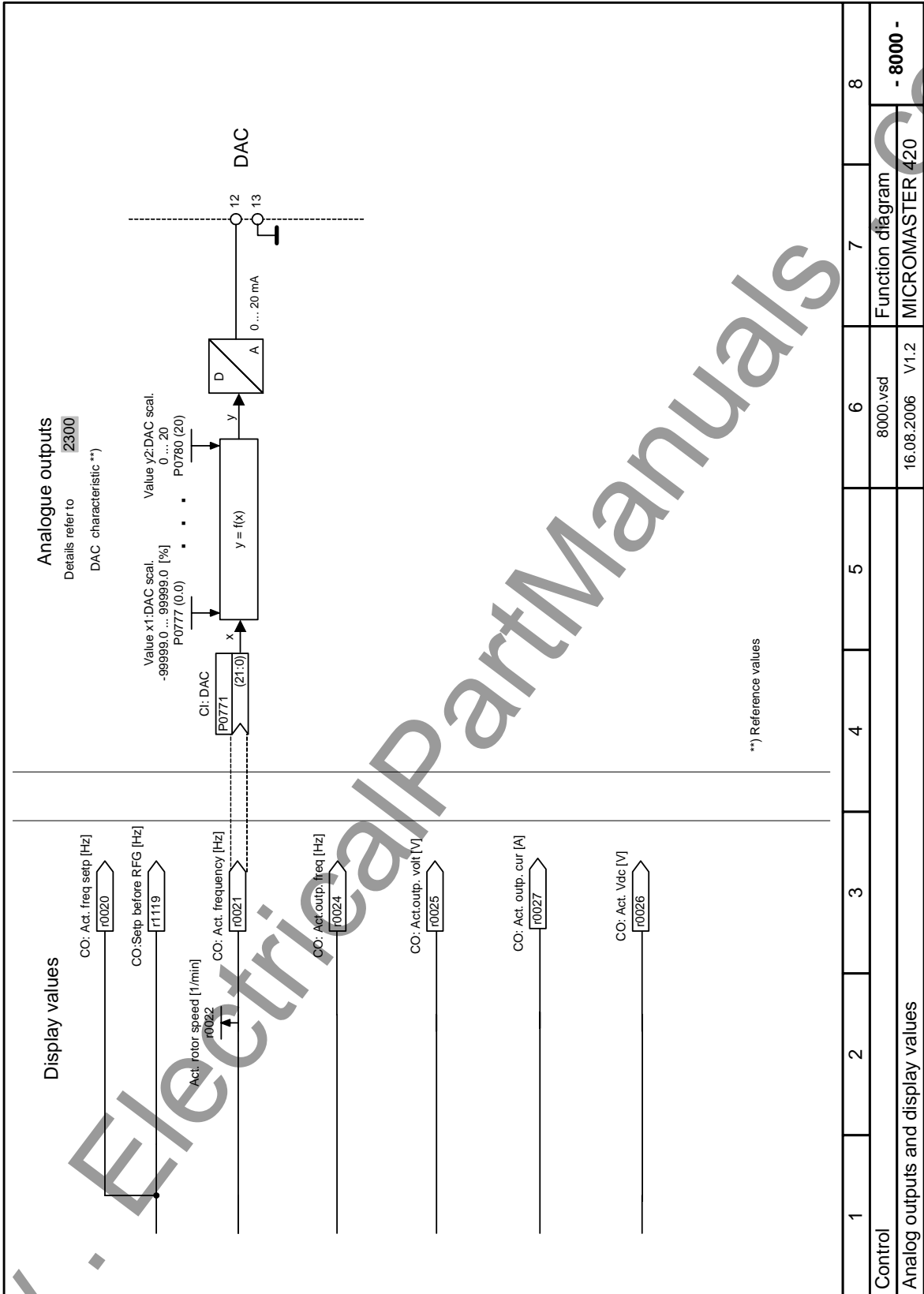

[www.ElectricalPartManuals.com](http://www.ElectricalPartManuals.com)

## 5 Faults and Alarms

### 5.1 Fault messages

In the event of a failure, the inverter switches off and a fault code appears on the display.

#### NOTE

To reset the fault code, one of three methods listed below can be used:

1. Cycle the power to the drive.
2. Press the **Fn** button on the BOP or AOP.
3. Via Digital Input 3 (default setting)

Fault messages are stored in parameter r0947 under their code number (e.g. F0003 = 3). The associated error value is found in parameter r0949. The value 0 is entered if a fault has no error value. It is furthermore possible to read out the point in time that a fault occurred (r0948) and the number of fault messages (P0952) stored in Parameter r0947.

#### F0001 Overcurrent STOP II

##### Quit

Remove fault and reset fault memory by

- disconnecting the drive converter from the line supply and powering-up again
- Press the Fn key on the BOP or AOP
- Acknowledge fault P2103, P2104
- P0952 (complete fault memory)

##### Cause

- short-circuit at the output
- ground fault
- excessively large motor (the motor power rating P0307 is greater than the inverter power r0206)
- defective final stage (end stage)

##### Diagnosis & Remedy

Please check the following:

- are the cable lengths within the limit values ?
- does the motor cable or motor have either a short-circuit or ground fault ?
- do the motor parameters correspond to those of the motor being used ?
- is the motor overloaded or stalled (locked rotor) ?
- increase the accelerating time.
- reduce the gain
- use a motor with a lower power rating
- is the stator resistance value (P0350) correct ?

#### F0002 Overvoltage STOP II

##### Quit

Refer to F0001.

##### Cause

- DC link voltage (r0026) higher than the overvoltage threshold (refer to parameter r0026)
- ground fault

##### Diagnosis & Remedy

Please check the following:

- is the line supply voltage within the permissible range?
- has the DC current DC link monitoring been enabled (P1240) and correctly parameterized?
- extend the deceleration ramp (ramp-down time P1121, P1135)
- remove the ground fault
- is the required braking power within the permissible limits?

#### NOTE

- a higher moment of inertia requires longer deceleration times; if required, use a braking resistor.
- overvoltage can either be caused by an excessively high line supply voltage or by the fact that the motor is generating (regenerative mode).
- the motor can be generating as it is decelerating quickly or due to the fact that an active load is driving the motor.

**F0003 Undervoltage STOP II**

**Quit**

Refer to F0001.

**Cause**

- line voltage failed
- shock stressing outside the permissible limits.

**Diagnosis & Remedy**

Please check the following:

- is the line supply voltage within the permissible range?
- is the line supply voltage stable with respect to sporadic failures and voltage dips (brown-outs) ?

**F0004 Inverter overtemperature STOP II**

**Quit**

Refer to F0001.

**Cause**

- inadequate cooling
- ambient temperature is too high.
- ambient temperature is too high.

**Diagnosis & Remedy**

Please check the following:

- is the pulse frequency P1800 set to the factory setting ? If required reset P1800.
- does the ambient temperature lie within the permissible limits ?
- reduce the load and / or ensure adequate cooling

Please check the following:

- does the fan rotate if the inverter is operational ?

**F0005 Inverter I2T STOP II**

**Quit**

Refer to F0001.

**Cause**

- inverter overloaded.
- load duty cycle too high.
- the motor power rating (P0307) is greater than that of the inverter (r0206).
- 100 % overload reached (refer to utilization r0036)

**Diagnosis & Remedy**

Please check the following:

- does the load duty cycle lie within the permissible limits?
- use a motor with a lower rating (motor power P0307 is greater than Is inverter power r0206)

**F0011 Motor overtemperature I2T STOP II**

**Quit**

Refer to F0001.

**Cause**

Motor overloaded

**Diagnosis & Remedy**

Please check the following:

- is the load cycle correct?
- is the thermal motor time constant (P0611) correct ?
- is the motor I2t alarm threshold correct ?

**F0035 Restart after n STOP II**

**Quit**

reset fault memory or Power On / Stop

**Cause**

- restart fault after n attempts, refer to P1211

<b>F0041</b>	<b>Failure, motor data identification</b>	<b>STOP II</b>
	<p><b>Quit</b> Refer to F0001.</p> <p><b>Cause</b> Motor data identification run unsuccessful (refer to fault value r0949):</p> <ul style="list-style-type: none"> <li>- r0949 = 0: Load missing.</li> <li>- r0949 = 1: Current limit value reached during identification.</li> <li>- r0949 = 2: Identified stator resistance less than 0.1% or greater than 100%.</li> <li>- r0949 = 30: Current controller at voltage limit value</li> <li>- r0949 = 40: Identified data set inconsistent; at least one identification run unsuccessful</li> </ul> <hr/> <p><b>NOTE</b> Percentage values based on the impedance <math>Z_b = V_{mot, rated} / \sqrt{3} / I_{mot, rated}</math></p> <p><b>Diagnosis &amp; Remedy</b> Please check the following:</p> <ul style="list-style-type: none"> <li>- r0949 = 0: Is the motor connected to the inverter ?</li> <li>- r0949 = 1-40: Is the motor data in P0304-P0311 correct ?</li> <li>- r0949 = 1-40: Motor circuit configuration correct (star, delta configuration) ?</li> </ul>	
<b>F0051</b>	<b>Parameter EEPROM fault</b>	<b>STOP II</b>
	<p><b>Quit</b> Refer to F0001.</p> <p><b>Cause</b></p> <ul style="list-style-type: none"> <li>- read or write operation while saving parameters in the EEPROM was unsuccessful.</li> </ul> <p><b>Diagnosis &amp; Remedy</b></p> <ul style="list-style-type: none"> <li>- reset to factory setting and then re-parameterize</li> <li>- if required, change the drive</li> </ul>	
<b>F0052</b>	<b>Power stack fault</b>	<b>STOP II</b>
	<p><b>Quit</b> Refer to F0001.</p> <p><b>Cause</b></p> <ul style="list-style-type: none"> <li>- read error, power data or invalid power module data.</li> </ul> <p><b>Diagnosis &amp; Remedy</b></p> <ul style="list-style-type: none"> <li>- change the drive</li> </ul>	
<b>F0060</b>	<b>Asic time slice overflow</b>	<b>STOP II</b>
	<p><b>Quit</b> Refer to F0001.</p> <p><b>Cause</b></p> <ul style="list-style-type: none"> <li>- internal communications failure/error</li> </ul> <p><b>Diagnosis &amp; Remedy</b></p> <ul style="list-style-type: none"> <li>- if the error still occurs, replace the inverter.</li> <li>- contact customer service!</li> </ul>	
<b>F0070</b>	<b>CB setpoint fault</b>	<b>STOP II</b>
	<p><b>Quit</b> Refer to F0001.</p> <p><b>Cause</b> no setpoints received via the communications bus during the telegram failure time. Triggered by A0702 / A0703 / A0704.</p> <p><b>Diagnosis &amp; Remedy</b></p> <ul style="list-style-type: none"> <li>- check the communications module (CB) and communications partner.</li> <li>- check connection to communication partners and ensure valid control word (see A0702 / A0703 / A0704)</li> </ul>	
<b>F0071</b>	<b>USS(BOP link) setpoint fault</b>	<b>STOP II</b>
	<p><b>Quit</b> Refer to F0001.</p> <p><b>Cause</b></p> <ul style="list-style-type: none"> <li>- no setpoint was received via the USS during the telegram off time</li> </ul> <p><b>Diagnosis &amp; Remedy</b></p> <ul style="list-style-type: none"> <li>- check USS master</li> </ul>	

<b>F0072</b>	<b>USS(COMM link) setpoint fault</b>	<b>STOP II</b>
	<p><b>Quit</b> Refer to F0001.</p> <p><b>Cause</b></p> <ul style="list-style-type: none"> <li>- no setpoints received via the USS during the telegram off time</li> </ul> <p><b>Diagnosis &amp; Remedy</b></p> <ul style="list-style-type: none"> <li>- check USS master</li> </ul>	
<b>F0080</b>	<b>ADC input signal lost</b>	<b>STOP II</b>
	<p><b>Quit</b> Refer to F0001.</p> <p><b>Cause</b></p> <ul style="list-style-type: none"> <li>- wire breakage</li> <li>- signal outside the limit values</li> </ul>	
<b>F0085</b>	<b>External fault</b>	<b>STOP II</b>
	<p><b>Quit</b> Refer to F0001.</p> <p><b>Cause</b></p> <ul style="list-style-type: none"> <li>- external fault as a result of command input via terminals.</li> </ul> <p><b>Diagnosis &amp; Remedy</b></p> <ul style="list-style-type: none"> <li>- inhibit terminal input to initiate fault.</li> </ul>	
<b>F0101</b>	<b>Stack overflow</b>	<b>STOP II</b>
	<p><b>Quit</b> Refer to F0001.</p> <p><b>Cause</b></p> <ul style="list-style-type: none"> <li>- software error or processor failure</li> </ul> <p><b>Diagnosis &amp; Remedy</b></p> <ul style="list-style-type: none"> <li>- carry-out self-test routines</li> </ul>	
<b>F0221</b>	<b>PID feedback below the minimum value</b>	<b>STOP II</b>
	<p><b>Quit</b> Refer to F0001.</p> <p><b>Cause</b></p> <ul style="list-style-type: none"> <li>- PID feedback below the minimum value P2268.</li> </ul> <p><b>Diagnosis &amp; Remedy</b></p> <ul style="list-style-type: none"> <li>- change value of P2268.</li> <li>- set feedback gain.</li> </ul>	
<b>F0222</b>	<b>PID feedback above maximum value</b>	<b>STOP II</b>
	<p><b>Quit</b> Refer to F0001.</p> <p><b>Cause</b></p> <ul style="list-style-type: none"> <li>- PID feedback above maximum value P2267.</li> </ul> <p><b>Diagnosis &amp; Remedy</b></p> <ul style="list-style-type: none"> <li>- change value of P2267.</li> <li>- set the feedback gain.</li> </ul>	
<b>F0422</b>	<b>No load applied to inverter</b>	<b>STOP II</b>
	<p><b>Quit</b> Refer to F0001.</p> <p><b>Cause</b></p> <p>No Load is applied to the inverter. As a result, some functions may not work as under normal load conditions.</p>	

**F0450 Failure BIST tests****STOP II****Quit**

Refer to F0001.

**Cause**

Self-test routine unsuccessful (refer to fault value r0949):

- r0949 = 1: Self-test routine for power module components unsuccessful
- r0949 = 2: Self-test routine for closed-loop control module components unsuccessful
- r0949 = 4: Several function tests were unsuccessful
- r0949 = 8: Several tests carried-out at the I/O module were unsuccessful (only MICROMASTER 420)
- r0949 = 16: Failure of the internal RAM at the switch-on test

**Diagnosis & Remedy**

- the drive is functional, but several functions are not correctly executed.
- replace the drive

## 5.2 Alarm Messages

Alarm messages are stored in parameter r2110 under their code number (e.g. A0503 = 503) and can be read out from there.

### A0501 Current limit value

#### Cause

- the motor power rating does not correspond to the inverter power rating
- motor cables are too long
- ground fault

#### Diagnosis & Remedy

Please check the following:

- does the motor power rating (P0307) match the inverter power rating (r0206) ?
- are the limit values for the cable lengths maintained ?
- does the motor cable or motor have a short-circuit or ground fault ?
- do the motor parameters correspond to those of the motor being used ?
- stator resistance value (P0350) correct ?
- is the motor overloaded or is the rotor locked (cannot rotate) ?
- ramp-up time P1120 too low ?

### A0502 Overvoltage limit value

#### Cause

- the overvoltage limit value has been reached (actual value of the DC link voltage r0026 greater than r1242).

#### Diagnosis & Remedy

- if this alarm is permanently displayed, check the inverter input voltage.
- is the DC link voltage controller (Vdc\_max controller) de-activated (refer to parameter P1240) ?
- short ramp times and/or large flywheel masses (moment of inertia) ?

### A0503 Undervoltage limit value

#### Cause

- line supply has failed.
- line voltage and therefore also the DC link voltage (r0026) below the defined limit value (refer to parameter r0026).

#### Diagnosis & Remedy

- check the line voltage.

### A0504 Inverter overtemperature

#### Cause

- alarm threshold of the inverter heatsink temperature (P0614) was exceeded; this results in a reduction of the pulse frequency and/or the output frequency (dependent on the parameterization in (P0610).

#### Diagnosis & Remedy

Please check the following:

- is the ambient temperature within the permissible limits ?
- are the load and load duty cycle within the permissible limits ?

### A0505 Inverter I2T

#### Cause

- overload alarm limit P0294 is exceeded (refer to utilization r0036)
- the pulse frequency and/or the output frequency is reduced as a function of the setting of parameter P0290.

#### Diagnosis & Remedy

- check whether the load duty cycle lies within the permissible limits.

### A0511 Motor overtemperature I2T

#### Cause

- motor is overloaded.
- load duty cycle is exceeded.

#### Diagnosis & Remedy

Please check the following:

- value P0611 (motor I2t time constant) suitable?
- is P0614 (motor I2t overload alarm) set to a suitable value?

**A0541 Motor data identification routine active****Cause**

- motor data identification routine (P1910) selected and is active

**A0571 Auto restart after fault present****A0600 RTOS data loss alarm****Cause**

- time slice overflow was identified

**Diagnosis & Remedy**

- use lower baud rate for USS
- de-activate inverter functions

**A0700 CB alarm 1****Cause**

- The parameter or configuring settings by the PROFIBUS master are invalid.

**Diagnosis & Remedy**

- Correct the PROFIBUS configuration.

**A0701 CB alarm 2****Cause**

- CB-(communications module)-specific

**Diagnosis & Remedy**

- refer to the CB User Manual

**A0702 CB alarm 3****Cause**

- The link to the PROFIBUS is interrupted.

**Diagnosis & Remedy**

- Check connector, cable and PROFIBUS master.

**A0703 CB alarm 4****Cause**

- No setpoints, or invalid setpoints (control word = 0) are being received from the PROFIBUS master

**Diagnosis & Remedy**

- Check setpoints from the PROFIBUS master. Switch SIMATIC CPU to "RUN".

**A0704 CB alarm 5****Cause**

- At least one configured internode transmitter is not yet active, or has failed.

**Diagnosis & Remedy**

- Activate internode transmitter.

**A0705 CB alarm 6****Cause**

- No actual values received from inverter.

**Diagnosis & Remedy**

- fault is in inverter.

**A0706      CB alarm 7**

**Cause**

- PROFIBUS-DP communication board: Software error.

**Diagnosis & Remedy**

- fault on the PROFIBUS-DP communication board, for details see diagnostic parameter.

**A0707      CB alarm 8**

**Cause**

- CB-(Communications module)-specific

**Diagnosis & Remedy**

- refer to the CB User Manual

**A0708      CB alarm 9**

**Cause**

- CB-(Communications module)-specific

**Diagnosis & Remedy**

- refer to the CB User Manual

**A0709      CB alarm 10**

**Cause**

- CB-(Communications module)-specific

**Diagnosis & Remedy**

- refer to the CB User Manual

**A0710      CB communications error**

**Cause**

- loss of communications with the CB (communications module).

**Diagnosis & Remedy**

- check the CB hardware.

**A0711      CB communications error**

**Cause**

- CB (communications module) signals a communications error.

**Diagnosis & Remedy**

- check the CB parameters

**A0910      Vdc-max controller disabled/switched-out**

**Cause**

- Vdc max controller was de-activated, as it was not able to keep the DC link voltage (r0026) within the limit values (refer to r0026 and P1240).

This occurs,

- if the line supply voltage is permanently too high.
- if the motor is driven by an active load, which means that the motor goes into regenerative operation.
- while decelerating (short down-ramps P1121) for extremely high load torques

**Diagnosis & Remedy**

Please check the following:

- is the input voltage (P0756) within the permissible range ?
- are load duty cycle and load limits within the permissible limits ?

**A0911      Vdc-max controller active**

**Cause**

- Vdc max controller is active
- the ramp-down times are automatically increased in order to keep the DC link voltage (r0026) within the limit values (refer to r0026 and P1240).

**A0912 Vdc-min controller active****Cause**

- Vdc min controller is activated, if the DC link voltage (r0026) falls below the minimum value (refer to r0026 or P1240).
- the kinetic energy of the motor is used to buffer the DC link voltage and therefore to slow down the drive.
- therefore brief line failures no longer automatically result in an undervoltage trip.

**A0920 ADC parameters not correctly set****Cause**

- ADC parameters should not be set to identical values, as this would lead to illogical results.
- Index 0: Parameter settings for output identical.
  - Index 1: Parameter settings for input identical.
  - Index 2: Parameter settings for input do not correspond to ADC type.

**A0921 DAC parameters not set properly.****Cause**

- DAC parameters (P0777 and P0779) have identical values.
- OR
- DAC parameters (P0778 and P0780) have identical values.
- Identical values would produce illogical results.

**Diagnosis & Remedy**

Check the following:

- Output parameter settings. Ensure P0777 and P0779 are not identical.
- Input parameter settings. Ensure P0778 and P0780 are not identical.

**A0922 No load at the inverter****Cause**

- no load is connected to the inverter.
- therefore several functions can run differently than under normal load conditions.

**A0923 JOG counter-clockwise as well as JOG clockwise are requested****Cause**

- both JOG clockwise and JOG counter-clockwise (P1055/P1056) have been requested. This is the reason that the RFG output frequency has been frozen to the actual value.

www.ElectricalPartManuals.com

## 6 Abbreviations

AC	Alternating current
AD	Analog digital converter
ADC	Analog digital converter
ADR	Address
AFM	Additional frequency modification
AIN	Analog input
AOP	Advanced operator panel
AOUT	Analog output
ASP	Analog setpoint
ASVM	Asymmetric space vector modulation
BCC	Block check character
BCD	Binary-coded decimal code
BI	Binector input
BICO	Binector / connector
BO	Binector output
BOP	Basic operator panel
C	Commissioning
CB	Communication board
CCW	Counter-clockwise
CDS	Command data set
CFM	Cubic feet per minute (1 l/s $\cong$ 2,1 CFM)
CI	Connector input
CM	Configuration management
CMD	Commando
CMM	Combimaster
CO	Connector output
CO/BO	Connector output / Binector output
COM	Common (terminal that is connected to NO or NC)
COM-Link	Communication link
CT	Commissining, ready to run
CT	Constant torque
CUT	Commissining, run, ready to run
CW	Clockwise
DA	Digital analog converter
DAC	Digital analog converter
DC	Direct current
DDS	Drive data set
DIN	Digital input
DIP	DIP switch
DOUT	Digital output
DS	Drive state
EEC	European Economic Community
EEPROM	Electrical erasable programmable read-only
ELCB	Earth leakage circuit breaker
EMC	Electro-magnetic compatibility

EMF	Electromotive force
EMI	Electro-magnetic interference
FAQ	Frequently asked questions
FCC	Flux current control
FCL	Fast current limit
FF	Fixed frequency
FFB	Free function block
FOC	Field orientated control
FSA	Frame size A
GSG	Getting started guide
GUI ID	Global unique identifier
HIW	Main actual value
HSW	Main setpoint
HTL	High-threshold logic
HVAC	heating, ventilation, air conditioning
I/O	Input and output
IBN	Commissioning
IGBT	Insulated gate bipolar transistor
IND	Sub-index
JOG	Jog
KIB	Kinetic buffering
LCD	Liquid crystal display
LED	Light emitting diode
LGE	Length
MHB	Motor holding brake
MM4	MICROMASTER 4th. Generation
MOP	Motor potentiometer
NC	Normally closed
NO	Normally open
OPI	Operating instructions
PDS	Power drive system
PID	PID controller (proportional, integral, derivative)
PKE	Parameter ID
PKW	Parameter ID value
PLC	Programmable logic controller
PLI	Parameter list
PPO	Parameter process data object
PTC	Positive temperature coefficient
PWE	Parameter value
PWM	Pulse-width modulation
PX	Power extension
PZD	Process data
QC	Quick commissioning
RAM	Random-access memory
RCCB	Residual current circuit breaker
RCD	Residual current device
RFG	Ramp function generator
RFI	Radio-frequency interference
RPM	Revolutions per minute

SCL	Scaling
SDP	Status display panel
SLVC	Sensorless vector control
STW	Control word
STX	Start of text
SVM	Space vector modulation
TTL	Transistor-transistor logic
USS	Universal serial interface
VC	Vector control
VT	Variable torque
ZSW	Status word

www.ElectricalPartManuals.com

www.ElectricalPartManuals.com

### Suggestions and/or Corrections

To  
Siemens AG  
Automation & Drives Group  
SD SPA PM4  
P.O. Box 3269

D-91050 Erlangen  
Federal Republic of Germany

Email:  
[documentation.sd@siemens.com](mailto:documentation.sd@siemens.com)

Suggestions Corrections
For Publication/Manual: MICROMASTER 420 Parameter List
User Documentation
Order number: 6SE6400-5BA00-0BP0 Date of Issue: 10/06
Should you come across any printing errors when reading this publication, please notify us on this sheet. Suggestions for improvement are also welcome.

**From**

Name:

Company/Service Department

Address: \_\_\_\_\_

Phone: \_\_\_\_\_ / \_\_\_\_\_

Fax: \_\_\_\_\_ / \_\_\_\_\_

[www.ElectricalPartManuals.com](http://www.ElectricalPartManuals.com)

www.ElectricalPartManuals.com

www.ElectricalPartManuals.com

Siemens AG  
Automation and Drives Group (A&D)  
Standard Drives (SD) Division  
Postfach 3269, D-91050 Erlangen  
Federal Republic of Germany

© Siemens AG, 2001, 2002, 2004, 2006  
Subject to change without prior notice

Siemens Aktiengesellschaft

Order No.: 6SE6400-5BA00-0BP0

