

# SIEMENS

## SIMATIC HMI

### WinCC flexible 2005 Runtime

#### User's Manual

#### Preface

---

Introduction to WinCC  
flexible Runtime

---

1

Functional scope

---

2

System prerequisites

---

3

Setting up WinCC flexible  
Runtime

---

4

Runtime functionality

---

5

Operating a project in  
Runtime

---

6

HMI system alarms

---

7

Order number 6AV6691-1BA01-0AB0

Edition 06/2005

A5E00280178-02

## Safety Guidelines

This manual contains notices you have to observe in order to ensure your personal safety, as well as to prevent damage to property. The notices referring to your personal safety are highlighted in the manual by a safety alert symbol, notices referring to property damage only have no safety alert symbol. These notices shown below are graded according to the degree of danger.



### Danger

indicates that death or severe personal injury **will** result if proper precautions are not taken.



### Warning

indicates that death or severe personal injury **may** result if proper precautions are not taken.



### Caution

with a safety alert symbol, indicates that minor personal injury can result if proper precautions are not taken.

### Caution

without a safety alert symbol, indicates that property damage can result if proper precautions are not taken.

### Notice

indicates that an unintended result or situation can occur if the corresponding information is not taken into account.

If more than one degree of danger is present, the warning notice representing the highest degree of danger will be used. A notice warning of injury to persons with a safety alert symbol may also include a warning relating to property damage.

## Qualified Personnel

The device/system may only be set up and used in conjunction with this documentation. Commissioning and operation of a device/system may only be performed by **qualified personnel**. Within the context of the safety notes in this documentation qualified persons are defined as persons who are authorized to commission, ground and label devices, systems and circuits in accordance with established safety practices and standards.

## Prescribed Usage

Note the following:



### Warning

This device may only be used for the applications described in the catalog or the technical description and only in connection with devices or components from other manufacturers which have been approved or recommended by Siemens. Correct, reliable operation of the product requires proper transport, storage, positioning and assembly as well as careful operation and maintenance.

## Trademarks

All names identified by © are registered trademarks of the Siemens AG. The remaining trademarks in this publication may be trademarks whose use by third parties for their own purposes could violate the rights of the owner.

### Copyright Siemens AG 2005. All rights reserved.

The distribution and duplication of this document or the utilization and transmission of its contents are not permitted without express written permission. Offenders will be liable for damages. All rights, including rights created by patent grant or registration of a utility model or design, are reserved.

### Disclaimer of Liability

We have reviewed the contents of this publication to ensure consistency with the hardware and software described. Since variance cannot be precluded entirely, we cannot guarantee full consistency. However, the information in this publication is reviewed regularly and any necessary corrections are included in subsequent editions.

Siemens AG  
Automation and Drives  
Postfach 4848, 90327 Nuremberg, Germany

© Siemens AG 2005  
Technical data subject to change

# Preface

## Preface

### Purpose of this manual

This user manual is part of the WinCC flexible documentation. The manual provides you with a comprehensive overview of working in WinCC flexible Runtime. The manual supports you in simulating new projects on your programming computer, in transferring a project to an HMI device and in working with WinCC flexible Runtime.

The readership addressed by this manual are newcomers, system migrators, operators and engineers who are concerned with operation, configuration, commissioning and service tasks using WinCC flexible.

### Basic Knowledge Requirements

General knowledge in the field of automation engineering is required to understand this manual.

You should also have experience of using PCs running under the Windows 2000 or Windows XP operating systems.

### Scope of the manual

This manual applies to the WinCC flexible 2005 Runtime software package.

### Position in the information scheme

This manual is part of the SIMATIC HMI documentation. The information below presents an overview of the information landscape of SIMATIC HMI.

#### User manual

- WinCC flexible Micro
  - describes the engineering basics based on the WinCC flexible Micro engineering system (ES)
- WinCC flexible Compact/ Standard/ Advanced
  - describes the engineering basics based on the WinCC flexible Compact, WinCC flexible Standard and WinCC flexible Advanced engineering systems (ES)
- WinCC flexible Runtime:
  - Describes how to commission and operate your Runtime project on a PC.

- WinCC flexible Migration:
  - Describes how to convert an existing ProTool project to WinCC flexible.
  - Describes how to convert an existing WinCC project to WinCC flexible.
  - Describes how to migrate ProTool projects with an HMI migration from OP7 to OP 77B or OP 73micro.
  - Describes how to migrate ProTool projects with an HMI migration from OP7 to OP 77B or OP 77A.
  - Describes how to migrate ProTool projects with an HMI migration from OP17 to OP 177B.
  - Describes how to migrate ProTool projects with HMI migration from graphic devices to Windows CE devices.
- Communication:
  - Communication Part 1 describes the connection of the HMI device to SIMATIC PLCs.
  - Communication Part 2 describes the connection of the HMI device to third-party PLCs.

### Operating Instructions

- Operating instructions for SIMATIC operating units:
  - OP 73, OP 77A, OP 77B
  - TP 170micro, TP 170A, TP 170B, OP 170B
  - OP 73micro, TP 177micro
  - TP 177A, TP 177B, OP 177B
  - TP 270, OP 270
  - MP 270B
  - MP 370
- Operating instructions for mobile SIMATIC operating units:
  - Mobile Panel 170
- Operating instructions (compact) for SIMATIC operating units:
  - OP 77B
  - Mobile Panel 170

### Getting Started

- WinCC flexible for first time users:
  - Based on a sample project, this is a step-by-step introduction to the basics of configuring screens, alarms, and recipes, and screen navigation.
- WinCC flexible for advanced users:
  - Based on a sample project, this is a step-by-step introduction to the basics of configuring logs, project reports, scripts, user management, and multilingual projects, and integration into STEP 7.
- WinCC flexible options:
  - Based on a sample project, this is a step-by-step introduction to the basics of configuring the WinCC flexible Audit, Sm@rtServices, Sm@rtAccess and OPC Server options.

### Online availability

The following links provide direct access to technical documentation on SIMATIC products and systems in English, German, French, Italian, and Spanish.

- SIMATIC Guide Technische Dokumentation in Deutsch:  
["http://www.ad.siemens.de/simatic/portal/html\\_00/techdoku.htm"](http://www.ad.siemens.de/simatic/portal/html_00/techdoku.htm)
- SIMATIC Guide for Technical Documentation in English:  
["http://www.ad.siemens.de/simatic/portal/html\\_76/techdoku.htm"](http://www.ad.siemens.de/simatic/portal/html_76/techdoku.htm)

### Guide

Structure of this manual:

- Introduction to WinCC flexible Runtime – Chapters 1-3
- Commissioning WinCC flexible Runtime – Chapter 4
- Operating in Runtime – Chapters 5-6
- HMI system alarms – Chapter 7

### Conventions

This documentation uses the term "HMI device" for all systems operating with WinCC flexible Runtime.

A distinction is made in the naming conventions for the configuration and runtime software:

- "WinCC flexible 2005" refers to the configuration software.
- "Runtime" designates the runtime software running on the HMI devices.
- "WinCC flexible Runtime" designates the visualization product for use on standard PCs or panel PCs.

The term "WinCC flexible" is used in the general context. A version name such as "WinCC flexible 2005" is used whenever it is necessary to distinguish it from other versions.

The following conventions are used in the text and will help you to read the manual more effectively:

Notation	Scope
"Add screen"	<ul style="list-style-type: none"> <li>• Terminology that occurs in the user interface, e.g., dialog names, tabs, buttons, menu commands.</li> <li>• Inputs required, e.g., limit values, tag values</li> <li>• Path information</li> </ul>
"File > Edit"	Operational sequences, e.g., menu commands/shortcut menu commands.
<F1>, <Alt + P>	Keyboard inputs

Please observe notes labeled as follows:

#### Note

Notes containing important information about the product and its use or a specific section of the documentation to which you should pay particular attention.

## Trademarks

HMI®
SIMATIC®
SIMATIC HMI®
SIMATIC ProTool®
SIMATIC WinCC®
SIMATIC WinCC flexible®

Third parties using for their own purposes any other names in this documentation which refer to trademarks might infringe upon the rights of the trademark owners.

## Further Support

If you have any technical questions, please get in touch with your Siemens representative or agent responsible.

You will find your contact person at:

["http://www.siemens.com/automation/partner"](http://www.siemens.com/automation/partner)

You will find a guide to the technical documentation offered for the individual SIMATIC Products and Systems here at:

["http://www.siemens.com/simatic-tech-doku-portal"](http://www.siemens.com/simatic-tech-doku-portal)

The online catalog and order system is found under:

["http://mall.automation.siemens.com/"](http://mall.automation.siemens.com/)

## Training Centers

Siemens offers a number of training courses to familiarize you with the SIMATIC S7 automation system. Please contact your regional training center or our central training center in D 90327 Nuremberg, Germany for details:

Telephone: +49 (911) 895-3200.

Internet: ["http://www.sitrain.com"](http://www.sitrain.com)

## Technical Support

You can reach the Technical Support for all A&D products via the Web formula for the Support Request "<http://www.siemens.com/automation/support-request>"

Phone: + 49 180 5050 222

Fax: + 49 180 5050 223

Additional information about our Technical Support can be found on the Internet pages "<http://www.siemens.com/automation/service>"

## Service & Support on the Internet

In addition to our documentation, we offer our Know-how online on the internet at:

"<http://www.siemens.com/automation/service&support>"

where you will find the following:

- The newsletter, which constantly provides you with up-to-date information on your products.
- The right documents via our Search function in Service & Support.
- A forum, where users and experts from all over the world exchange their experiences.
- Your local representative for Automation & Drives.
- Information on field service, repairs, spare parts and more under "Services".

[www.ElectricalPartManuals.com](http://www.ElectricalPartManuals.com)

## Table of contents

	Preface .....	i
<b>1</b>	<b>Introduction to WinCC flexible Runtime .....</b>	<b>1-1</b>
<b>2</b>	<b>Functional scope.....</b>	<b>2-1</b>
<b>3</b>	<b>System prerequisites .....</b>	<b>3-1</b>
<b>4</b>	<b>Setting up WinCC flexible Runtime.....</b>	<b>4-1</b>
4.1	Installing WinCC flexible Runtime.....	4-1
4.2	Electrical installation .....	4-2
4.3	Connection to the controller.....	4-3
4.4	Settings of the Runtime software.....	4-4
4.5	Test project .....	4-5
4.6	Transferring a project.....	4-6
4.7	Run the project.....	4-8
4.8	Backup configuration data .....	4-9
4.9	Stop runtime.....	4-9
<b>5</b>	<b>Runtime functionality .....</b>	<b>5-1</b>
5.1	Screen objects in Runtime.....	5-1
5.2	Alarms in Runtime.....	5-2
5.3	Tags in Runtime.....	5-4
5.4	Log files in Runtime .....	5-4
5.5	Recipes in Runtime.....	5-6
5.5.1	Recipes in Runtime.....	5-6
5.5.2	Structure of recipes.....	5-7
5.5.3	Structure of recipe data records.....	5-8
5.5.4	Recipe application.....	5-9
5.5.4.1	Transfer of recipe data records.....	5-9
5.5.4.2	Configuration of recipes .....	5-10
5.5.4.3	Scenario: Entering recipe data records in Runtime .....	5-12
5.5.4.4	Scenario: Manual production sequence .....	5-13
5.5.4.5	Scenario: Automatic production sequence .....	5-15
5.5.5	Displaying recipes.....	5-16
5.5.5.1	Viewing and editing recipes in Runtime.....	5-16
5.5.5.2	Behavior of the recipe view in Runtime .....	5-18
5.5.6	Recipe data record administration .....	5-18
5.5.6.1	Recipe data record administration .....	5-18
5.5.6.2	Synchronizing a recipe data record .....	5-20
5.5.6.3	Read recipe data record from PLC .....	5-21
5.5.6.4	Transfer recipe record to PLC.....	5-21

5.5.6.5	Exporting and importing recipe data records .....	5-22
5.5.6.6	Reactions to modifications of the recipe structure .....	5-23
5.5.7	Example .....	5-24
5.5.7.1	Example: Creating a recipe.....	5-24
5.5.7.2	Example: Configuring a recipe screen .....	5-26
5.6	Reports in Runtime .....	5-27
5.7	System functions and scripts in Runtime.....	5-28
5.8	Security in Runtime .....	5-29
5.9	Further operating options in Runtime.....	5-31
<b>6</b>	<b>Operating a project in Runtime .....</b>	<b>6-1</b>
6.1	Basics for operation in Runtime .....	6-1
6.1.1	Introduction .....	6-1
6.1.2	Operation with mouse and keyboard .....	6-2
6.1.3	Operating the touch screen device .....	6-4
6.1.3.1	Operating touch objects .....	6-4
6.1.3.2	Input of values.....	6-5
6.1.3.3	Entering alphanumeric values.....	6-6
6.1.3.4	Entering numeric values.....	6-7
6.1.3.5	Calling the infotext.....	6-8
6.2	Operating graphic objects .....	6-9
6.2.1	Button .....	6-9
6.2.2	Switch.....	6-10
6.2.3	IO field .....	6-12
6.2.4	Graphic I/O field .....	6-14
6.2.5	Symbolic IO field .....	6-15
6.2.6	Alarm indicator .....	6-16
6.2.7	Alarm view.....	6-17
6.2.8	Simple alarm view .....	6-19
6.2.9	Recipe view .....	6-21
6.2.10	Simple recipe view .....	6-24
6.2.11	Bar.....	6-26
6.2.12	Trend view.....	6-27
6.2.13	Slider control .....	6-29
6.2.14	Gauge.....	6-30
6.2.15	Date/time field .....	6-31
6.2.16	Clock .....	6-32
6.2.17	User view .....	6-33
6.2.18	Simple user view .....	6-35
6.2.19	Symbol library .....	6-37
6.2.20	Status force .....	6-38
6.2.21	HTML browser.....	6-40
6.2.22	Sm@rtClient view.....	6-42
<b>7</b>	<b>HMI system alarms.....</b>	<b>7-1</b>

# Introduction to WinCC flexible Runtime

## Introduction

WinCC flexible Runtime is a high-performance and comprehensive software for the visualization of processes in projects you created with the WinCC flexible Advanced programming software.

Modern automation concepts are extremely demanding on process visualization. Process control close to machines must in particular meet the demands for simple, high-performance control of the processes. The goal is to present process data to the operator quickly and clearly in a form that can be easily understood, such as a trend display. This increasingly requires process displays that simplify understanding of the actual process. It is also becoming more important to be able to archive the data, e.g. for quality control. This makes it necessary to log process data at machine level.

WinCC flexible Runtime is designed for visualization and operation of machines and small systems. The Runtime software has a window-based pixel-graphics user interface. Due to its short response times, the software features secure process operation, jogging at the machine and secure data acquisition.

## Licensing

If you install the WinCC flexible Runtime software on a standard PC or a panel PC, you will require a license for unrestricted use. WinCC flexible Runtime runs in a non-licensed mode if the licensing is missing.

- PC: The license is supplied with WinCC flexible Runtime.
- Panel PCs: The license and WinCC flexible Runtime are supplied with the device.

## Components of WinCC flexible

The configuration software WinCC flexible Advanced is used to create your project data on a PC or PG that is operating on a Windows platform.

The process visualization software WinCC flexible Runtime is used to run the user program under Windows and to visualize the process. WinCC flexible Runtime is also used on the configuration computer to test and simulate the compiled project file.

There are also a number of options with enhanced functions available for WinCC flexible Runtime. These can be ordered separately as required.

www.ElectricalPartManuals.com

# Functional scope

## Dependencies of the functions

The functional scope of WinCC flexible Runtime depends on the following conditions:

- Hardware of the HMI device

The functionality is determined by the features of the HMI device used, such as memory capacity and the number of function keys.

- Licensing / licensing model

The scope of functions and performance is determined by the licensing and the licensing model, for example, with respect to the number of tags (power tags.)

- Runtime options

You can access additional functions by installing the options (e.g. remote access using the Sm@rtClient display.)

## Functional scope

Functionality of WinCC flexible Runtime:

- Convenient process visualization on a Windows-type user interface
- Large selection of standard I/O fields, bars, trend displays, vector graphics and buttons
- Integrated alarm system
- Dynamic positioning of objects
- Archiving of alarms and process values
- Recipes
- Visual Basic Script for user functions
- Standard couplings to SIMATIC S7, SIMATIC S5 and SIMATIC 505 as well as to PLCs from other manufacturers
- HTML browser
- Input protection by means of user groups, passwords and log off times
- Remote access using the Sm@rtClient view

www.ElectricalPartManuals.com

# System prerequisites

## System requirements for PCs

If you wish to run WinCC flexible Runtime on a PC, it must satisfy the following system requirements:

- Operating system: Windows 2000 SP4 or Windows XP Professional SP1/SP2
- Processor: minimum Pentium II, 233 MHz; recommended Pentium III, 500 MHz
- Graphic controller: minimum VGA; recommended SVGA with hardware acceleration
- Resolution: minimum 640 x 480 pixels; recommended 1024 x 768 to 1600 x 1200 pixels
- RAM: minimum 64 MB; recommended are 128 MB or more
- Free hard disk space: at least 100 MB (without considering log files)

In addition to the space needed by WinCC flexible Runtime, Windows also requires space on the hard disk, e.g. for the swap file. For further information, refer to your Windows documentation.

- CD-ROM drive
- For WinCC flexible Runtime licensing you must have access to a 3.5"/1.44 MB FD drive (direct or via Ethernet connection).

---

### Note

For multilingual configurations, use the MUI (multilingual user interface) version of the operating system.

---

[www.ElectricalPartManuals.com](http://www.ElectricalPartManuals.com)

# Setting up WinCC flexible Runtime

## 4.1 Installing WinCC flexible Runtime

### Supported devices

WinCC flexible Runtime will run on the following Windows-based systems:

- Standard PC
- SIMATIC Panel PCs: PC 670, PC 677, PC 870, PC 877, PC IL 70, PC IL 77
- SINUMERIK Panel PCs: OP 010, OP 012, OP 015, OP 015A, TP 012, TP 015A
- SIMOTION Panel PCs: P012K, P012T, P015K, P012T, PC-R Key, PC-R Touch

### Installation on the PC

Install System WinCC flexible Runtime on your system, if you have not done that yet.

Install WinCC flexible Runtime from the "WinCC flexible Runtime" CD. A license (license key) is required to run the Runtime software.

---

#### Notice

WinCC flexible Runtime runs in demo mode only if you do not have a license. In demo mode, you are prompted to acknowledge specific messages at regular intervals.

---

1. Install the runtime software from the CD.

If the autorun function is enabled for your CD-ROM drive, the CD browser is run automatically when the CD is inserted. Otherwise, run Setup by selecting "WinCCflexible\Runtime\setup.exe" from the CD.

2. Select the user interface language of the Setup program under "Language."
3. Select "Installation", then run the "WinCC flexible Runtime" setup.
4. Follow the setup instructions on the screen.
5. Install the license when you are prompted to do so.

---

#### Note

If, when installing the Runtime software, you do not have a license, you can install this later using the Automation License Manager. The Automation License Manager is automatically installed during the WinCC flexible installation.

---

## 4.2 Electrical installation

### Connecting the PC to the controller

The PC is connected to the controller via a communication processor or via the COM1 to COM4 ports. Please refer to the hardware description from the manufacturer for the proper electrical installation of your PC.

The table below shows the use of the interfaces:

Controller	PC interface
SIMATIC S5 over AS511	COM1 / COM2 requires an RS232/TTY adapter
SIMATIC S5 via PROFIBUS DP <sup>1)</sup>	via CP CP 5511, CP 5512, CP 5611
SIMATIC S7 via PPI	via CP CP 5511, CP 5512, CP 5611, CP 5613, CP 5614 via PC/PPI adapter <sup>2)</sup>
SIMATIC S7 via MPI	via CP CP 5511, CP 5512, CP 5611, CP 5613, CP 5614 via PC/MPI adapter <sup>3)</sup> via PC adapter USB <sup>3)</sup> via Teleservice V5.1
SIMATIC S7 via PROFIBUS DP <sup>4)</sup>	via CP CP 5511, CP 5512, CP 5611, CP 5613, CP 5614
SIMATIC S7 via Ethernet (TCP/IP)	via CP CP 1512, CP 1612, CP 1613
SIMATIC 505	COM1 / COM2, RS232 interface
SIMATIC 505 via PROFIBUS DP	via CP CP 5511, CP 5512, CP 5611
OPC	Ethernet network cards
Allen Bradley via DF, DH+, DH485	COM1 / COM2
LG (Lucky Goldstar) GLOFA GM	COM1 / COM2
Mitsubishi MELSEC	COM1 / COM2
Modicon MODBUS	COM1 / COM2
GE Fanuc	COM1 / COM2
Omron Hostlink/Multiink	COM1 / COM2

<sup>1)</sup> WinCC flexible Runtime is passive node (DP slave)

<sup>2)</sup> Point-to-point connection with S7-200 only, no configuration transfer

<sup>3)</sup> Point-to-point connection with S7-300 or S7-400 only

<sup>4)</sup> WinCC flexible Runtime is active node

## 4.3 Connection to the controller

### Connection to the controller

Connect your HMI device to the controller in order to allow you to simulate your project online with the controller. You can also test the project by calling the simulator. In this case, you do not need an online connection to the controller.

### Setting the PG / PC interface

#### PROFIBUS DP communication

1. Select "Start > Settings > Control Panel", then select "Set PG/PC interface."  
Select PROFIBUS under used module parameters.
2. Click "Properties". The DP profile is selected in the network parameters.
3. Select universal (DP/FMS), then confirm with OK.
4. Click "Properties" again.
5. Select the DP profile again, then confirm with OK.

#### MPI communication

1. Select "Start > Settings > Control Panel", then select "Set PG/PC interface."
2. Click "Properties", then set the parameters on the MPI network tab for the HMI device so that this is the only master on the bus.  
Only one of several HMI devices may be operated as master on the MPI bus. Verify the network settings of the connected devices.

---

#### Note

For comprehensive information relating to communication between the controller and the HMI device, refer to the communication user manual.

---

## 4.4 Settings of the Runtime software

### Principle

In the configuration software WinCC flexible, make the following settings for the Runtime software:

- Display on the PLC

In WinCC flexible, you configure the Runtime layout of the generated project: Select whether to start the project in full-screen mode, or in a window smaller than the screen size. In full-screen mode, the project is zoomed to the full screen. There will be no window and operator control elements for this view.

---

#### Note

If the HMI screen does not match the configured size (in pixels), the project appears only on a part of the screen when opened in full-screen mode.

---

To start the system in full-screen mode, open the "Device settings" dialog box in the project view in WinCC flexible. Under "Runtime Settings", set the "Full-screen mode" check box. You can hide the taskbar under Windows as required. To hide the taskbar, select "Start > Settings > Taskbar", then reset the "Always on Top" and "Auto hide" check boxes on the "Taskbar properties" dialog box.

- Disabling program switching

In order to prevent the operator from calling other applications in Runtime, you may lock program switching. To do so, open the "Device settings" dialog box in the project view, then set the "Disable program switching" and "Full-screen mode" check boxes. Also hide the taskbar under Windows as described earlier.

---

#### Note

If you decide to lock program switching, you should always configure a function key or button for calling the "StopRuntime" system function. Otherwise, it will not be possible to exit WinCC flexible Runtime or Windows.

When program switching is disabled, the <Ctrl+Alt+Del> keystroke function is also disabled. Under Windows 2000, this will make it impossible, for example, to log in to your device after the screensaver has started. In Windows 2000, you can disable the <Ctrl+Alt+Del> log-in key combination. Open the "Control Panel > Users > Passwords", then reset the "Press Ctrl + Alt + Del before logging on" check box on the "Advanced" tab.

- Screen saver

A screensaver is no longer required for most modern screens and can even damage them. These monitors switch to hibernate mode as soon as the video signal has not changed for a specified time. A conventional screensaver would prevent this and thus reduce the service life of your monitor.

---

**Note**

In case you do want to use a screensaver, please note that WinCC flexible Runtime is only released for operation with the standard Windows screensavers.

---

- Setting the time zone

Make sure that the correct time zone is set on the PC on which the runtime software is installed. To set the time zone in Windows, select Start > Settings > Control Panel > Date/Time.

## 4.5 Test project

### Function

WinCC flexible is supplied with a simulator software which you can use to test your project offline. The simulator is a separate application. It allows you to debug the functions of configured graphics, graphic objects, alarms etc.

The simulator simulates the control as follows:

- Defined modification of the values of configured tags, e.g. in increments or decrements, sine-wave, random or by bit-shifting.

The simulation/runtime components must also be installed on your programming device in order to run a simulation.

### Principle

You have various options of simulating your project:

- Simulation with controller connection

You can simulate you project directly in Runtime. In this case, tags and range pointers will only function if your programming device is interconnected with a corresponding controller.

By connecting your PC / PG to the controller, you can achieve an authentic simulation of your configured HMI device in Runtime. For simulation with WinCC flexible, select "Compiler" > "Start Runtime" from the "Project" menu. Alternatively, click on the  symbol in the "Compiler" toolbar.

- Simulation without controller connection

The simulation program installed with WinCC flexible Runtime allows offline simulation of your project, including its tags and flags. Specify the parameters of flags and tags in a simulation table that will be read by the simulation program of WinCC flexible Runtime.

For simulation with the simulator, select "Compiler > Start Runtime with simulator" from the "Project" menu. Alternatively, click on the  symbol in the "Compiler" toolbar.

- Simulation in integrated mode

An integrated configuration in STEP 7 allows you to simulate a controller connection with PLCSIM. For more information, please see the STEP 7 documentation.

### Handling instructions

The following steps show the basic procedures for simulating a project offline without controller connection.

1. Start by creating a project as it is going to be run later with an interconnected controller.
2. Save and compile the project.
3. Launch the simulator directly from the running configuration software. Select "Compiler" > start Runtime with simulator" from the "Project" menu. Alternatively, click on the  symbol in the "Compiler" toolbar.

When you simulate the project for the first time, the simulator is started with a new, empty simulation table. If you have already created a simulation table for your project, it will be opened.

The simulation table "\*.sim" contains all your settings for the simulation of tags and flags.

4. You now manipulate the tags and flags of your project in the simulation table.  
You can monitor the profile of the changing value by switching the task from simulation to the project.
5. You can save all settings made in this table for project simulation to a file. To do so, select "File > Save" in the Simulator, then type in a file name (\*.sim.)

You can now always retrieve these settings in order to simulate your project again. The condition is here, that you have not reconfigured any of the tags or flags you want to simulate in your project in the meantime.

## 4.6 Transferring a project

### Overview

Various scenarios are possible for transferring the project:

- WinCC flexible Runtime is installed on the same PC as the WinCC flexible programming software.
- WinCC flexible Runtime and the WinCC flexible programming software are installed on different systems. In this case, the project must be downloaded from the programming device to the destination device.
- ◆ In the first step, you need to set the corresponding transfer properties in the "Loader menu" on the HMI device.

---

**Note**

Depending on the configuration, the transfer safety prompt asks if you really want to overwrite the existing recipe data and password lists with the data from the configuration.

---

**The programming software and runtime software are on the same system**

If the configuration software and WinCC flexible Runtime are on the same system, proceed as follows:

1. Create the project and name it, for example, Myproject.hmi. Compile the project data in the next step.  
  
The compiled file with the file name extension \*.fwx will be stored in the folder containing the project file, e.g. "Myproject.fwx."
2. Start WinCC flexible Runtime directly from the running configuration software. Select "Compiler" > start Runtime" from the "Project" menu. Alternatively, click on the  symbol in the "Compiler" toolbar.
3. You may test and operate the project online with the controller if you have configured the corresponding communication.

**Configuration software and Runtime software on different systems**

If the programming software and WinCC flexible Runtime are installed on two different systems, proceed as follows:

1. Create the project and name it, for example, Myproject.hmi. Compile the project data in the next step.  
  
The compiled file with the file name extension \*.fwx, e.g. Myproject.fwx, is stored in the same folder.
2. To transfer the compiled file via cable:  
  
Depending on the required type of transfer, use a suitable standard cable to interconnect the HMI device with the programming device, then switch on the HMI device.

---

**Note**

If the HMI device is a PC, you can transfer the compiled file without using the loader, for example, via Ethernet. To do so, double-click the compiled file on your PC to start Runtime.

---

3. Download the compiled file from the programming device to your PLC.  
  
Windows provides the following options of transferring the compiled file:
  - Copy the file \*.fwx to the PLC via the parallel or serial interface, either via dial-up connection under Windows 2000 or the network.
  - Copy the \*.fwx file to a diskette and then from the diskette to the destination PC.

## 4.7 Runt the project

### Introduction

You can start the project immediately after its transfer.

### Project start modes

Options of starting a WinCC flexible project on a Runtime PC:

- Running it from the Explorer

You can run the project by double-clicking its file name in Windows Explorer.

- Starting together with Runtime

Enter the project file in "HmiRT.ini" in order to run it with the start of WinCC flexible Runtime by means of the Windows Start menu.

- Run from the command line

To run your project, type in the following command either at the MS-DOS prompt, or on the "Start > Run" command line in Windows, and then press <Enter>.

```
c:\Programs\Siemens\SIMATIC WinCC flexible\WinCC flexible 2005  
Runtime\HmiRTm.exe c:\project\myproject.fwx
```

- Autostart

– If your project is linked to the Autostart directory of the Windows start menu, it will be automatically upon system startup.

– It is also possible to define the autostart settings in the "Settings" dialog box of the WinCC flexible Runtime loader.

---

### Note

You can start the loader with the Windows Start menu command

"SIMATIC\WinCC flexible 2005 Runtime\WinCC flexible 2005 Runtime Loader".

---

## 4.8 Backup configuration data

### Principle

Several years of operation in a rugged industrial environment may damage the hard disk drive of your HMI device. To ensure that you can retrieve all programs and settings to the new hard disk, create a backup copy of your hard disk configuration data. Refer to the operating instructions of the HMI device for a detailed description of creating a backup.

### Procedure

1. Run the backup program as directed in the description included with the SIMATIC HMI device.

You have thus prepared the conditions for putting your HMI device into operation again without any significant loss of time after you replace the hard disk drive.

A commonly available software can also be used to generate a backup copy.

## 4.9 Stop runtime

### Introduction

You define the steps in closing Runtime in the user program:

### Procedure

1. When Runtime is running in window mode, you can close it simply by clicking "Close."
2. When Runtime is running in full-screen mode, you can close it by means of the program switching function and the Task Manager.
3. When Runtime is running in full-screen mode and program switching is disabled for the project, the closing sequence of Runtime must be configured separately. Actuate the relevant button to close Runtime.

www.ElectricalPartManuals.com

# Runtime functionality

## 5.1 Screen objects in Runtime

### Overview

WinCC flexible Runtime offers the following objects for operating and monitoring:

- Button
- Switch
- I/O field
- Graphic I/O field
- Symbolic IO field
- Alarm indicator
- Alarm view
- Alarm window
- Recipes view
- Bar
- Trend view
- Slider control
- Gauge
- Date/time field
- Clock
- User view
- Symbol library
- Status force
- HTML browser
- Sm@rtClient view

## 5.2 Alarms in Runtime

### Alarms

Alarms indicate events and states on the HMI device which have occurred in the system, in the process or on the HMI device itself. A status is reported when it is received.

An alarm could trigger one of the following alarm events:

- Activate
- Deactivate
- Acknowledge

The configuration engineer defines which alarms must be acknowledged by the user.

An alarm may contain the following information:

- Date
- Time
- Alarm text
- Location of fault
- Status
- Alarm class
- Alarm number
- Acknowledgement group

### Alarm classes

Alarms are assigned to various alarm classes.

- Operation

Warning alarms usually indicate states of a plant such as "Motor switched on". Alarms in this class do not require acknowledgement.

- Error

Alarms in this class must always be acknowledged. Alarms normally indicate critical errors within the plant such as "Motor temperature too high".

- System

System alarms indicate states or events which occur on the HMI device.

System alarms provide information on occurrences such as operator errors or communication faults.

- STEP 7 alarm classes

- ◆ The alarm classes configured in STEP 7 are also available to the HMI device.

- Custom alarm classes

The properties of this alarm class must be defined in the configuration.

### Alarm buffer

Alarm events are saved to an internal, volatile buffer. The size of this alarm buffer depends on the HMI device type.

### Alarm log

When alarm logging is enabled, alarm events are output directly to the printer.

You can set the logging function separately for each alarm. The system outputs "activated" and "deactivated" alarm events to the printer.

The output of alarms of the "System" class to a printer must be initiated by means of the corresponding alarm buffer. This outputs the content of the alarm buffer to the printer. To be able to initiate this print function, you need to configure a corresponding control object in the project.

### Alarm log

Alarm events are stored in an alarm log, provided this log file is configured. The capacity of the log file is limited by the storage medium and system limits.

### Alarm view

The alarm view shows selected alarms or events from the alarm buffer or alarm log. Whether alarm events have to be acknowledged or not is specified in your configuration.

### Alarm window

If configured, an alarm window shows all pending alarms or alarms awaiting acknowledgement of a particular alarm class. The alarm window is displayed as soon as a new alarm occurs.

You can configure the order in which the alarms are displayed. You can choose to display the alarms in ascending or descending order of their occurrence. The alarm window can also be set to indicate the exact location of the fault, including the date and time of the alarm event.

### Alarm indicator

The alarm indicator is a graphic symbol that is displayed on the screen when an alarm of the specified alarm class is activated.

The alarm indicator can have one of two states:

- Flashing: At least one unacknowledged alarm is pending.
- Static: The alarms are acknowledged but at least one of them is not yet deactivated. The number indicates the number of queued alarms.

## 5.3 Tags in Runtime

### Definition

Tags correspond to defined memory areas on the HMI device, to which values are written and/or from which values are read. This action can be initiated by the PLC, or by the operator at the HMI device.

## 5.4 Log files in Runtime

### Overview

Alarm events and process values can be saved to log files.

Examples of alarm events are the incoming, acknowledged and outgoing events occurring with an alarm message.

Process value logging is used for the following purposes, for example:

- Early detection of danger / fault states
- Increase of productivity
- Enhancement of product quality
- Optimization of maintenance cycles
- Documentation of processes
- Quality assurance

### Memory options

Depending on the configuration, the logs are written to a file or stored in a database set up for this purpose.

- Logging to a CSV file

The project engineer must have specified a folder path for storing the CSV file containing your logged data. This references the storage location.

CSV format table columns are separated by separators, the table rows are terminated by a line break character. This allows you to evaluate or edit your log data using an external text editor or spreadsheet program, for example.

- Logging to a database

By storing your log files in a database, you can utilize the full database functionality for further processing and analysis of the logged data.

- ◆ Databases tested and released for WinCC flexible:
  - MS Data Engine 97 and MS Data Engine 2000
  - MS Access 97 and MS Access 2000
  - MS SQL Server 7.0 and MS SQL Server 2000

Logging methods used in WinCC flexible Runtime:

- Circular log
- Segmented circular log
- Log with level-dependent system alarm
- Log file with data volume-based system alarm

## Alarm logs

Alarms in the project indicate fault states and operating states of a process. They are generally triggered by the controller. Alarms can be output to the HMI in the form of images. WinCC flexible lets you log alarms and document operational states and error states of the plant.

The following data are logged to the file:

- Date and time of alarm
- Alarm number
- Alarm tags (up to 8)
- Alarm status
- Alarm text (optional)
- Fault location (optional)

All alarms are assigned to a specific alarm class. All alarm classes can be logged.

Alarms can be logged either automatically, or by operator intervention.

The contents of log files can be output to the HMI, if a corresponding alarm view has been configured.

## Data logs

In Runtime, the process values are logged, processed and, depending on the project, written either to files or to the log database.

Data logging is controlled by means of cyclic operations and events. Logging cycles are used to ensure continuous acquisition and storage of the data. In addition, data logging can also be triggered by events, e.g. when a value changes.

## 5.5 Recipes in Runtime

### 5.5.1 Recipes in Runtime

#### Overview

Recipes are a collection of associated data, e.g. machine configuration or production data. You can transfer these data, for example, from the HMI device to the controller in a single step in order to change the production variant. If you have programmed directly at the machine, for example, you can transfer the data to your HMI device and write these to the recipe.

#### Operating recipes in Runtime

WinCC flexible offers two options of viewing and editing recipes and the corresponding recipe data records in Runtime on the HMI device:

- Recipes view
- Recipe screen

#### Recipes view

The recipe view is a screen object that is configured in the "Screens" editor. For example, you can specify what operating function the recipe view will have in Runtime:

Entry Name	Value

The recipe view shows recipe data records in tabular form. The Recipe view is particularly useful if data records are small in size or only a few values are to be modified.

## Recipe screen

A recipe screen represents a process screen which you configured as individual input screen form by means of an individual layout of I/O fields and other screen objects in the "Screens" editor. This makes it possible for you to input parameter data in the context of machine visualization. The I/O fields for a recipe can be distributed over multiple recipe screens, with topical organization of recipe elements, for example. The operating functions for the recipe screens must be configured explicitly in the process screens.

## 5.5.2 Structure of recipes

### Introduction

A product often has several variants. For example, product variants can differ with respect to size or quality. This condition is accurately reflected in a recipe.

### Principle

A recipe consists of recipe data records containing values. The structure of a recipe is explained using the example of a filing cabinet.

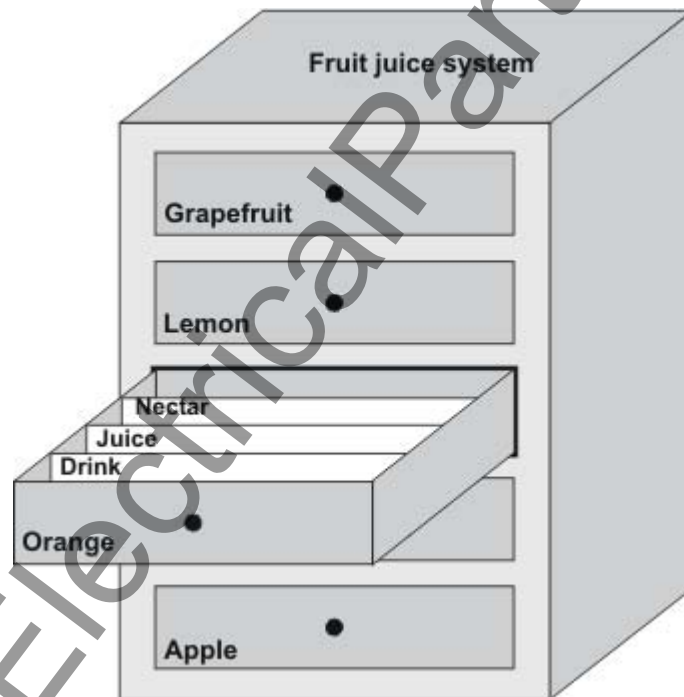

Each recipe represents a drawer of the file cabinet shown, and thus precisely one product. If the fruit juice mixing plant is producing orange, apple, and tropical fruit flavors, you would then configure one recipe for each flavor.

You define the recipe elements in the recipe. A recipe element consists of the display name and a tag. The display names are indicated in the recipe data records and on the HMI device in the recipe view. In Runtime, the appropriate tag value is read from the controller or transferred to the controller.

### 5.5.3 Structure of recipe data records

#### Introduction

A recipe data record corresponds to a file card in an individual drawer and thus to a single product variant. If the fruit juice mixing plant is producing juice, nectar, and fruit drinks, you would then create a recipe data record in the recipe for each product variant. In this case, the product variants consist of the different mixing ratios for the ingredients.

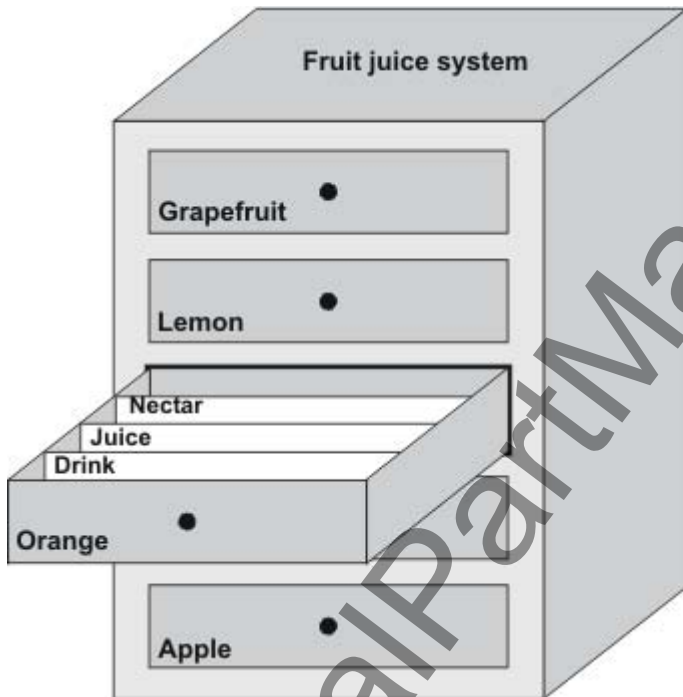

A recipe data record is a set of values for the tags defined in the recipe. You enter the values in the input fields. You can enter the values either during configuration or during runtime on the HMI device or the machine.

Elements		Data records					
	Name	Display name	Numb...	Water	Concentrate	Sugar	Aroma
☰	Beverage	Beverage	1	30	70	45	600
☰	Nektar	Nektar	2	50	50	10	300
☰	Juice	Juice	3	5	95	3	100

To produce a product, you transfer the appropriate recipe data record from the HMI device to the connected controller. The values in the recipe data record cannot be changed on the HMI device unless the configuring engineer has provided for this.

## Editing recipe data records

You can edit recipe data records during configuration or in runtime on the HMI device.

- During configuration, you can define recipes in the "Recipes" editor in the "Elements" tab. You can enter values in the recipe data records in the "Data records" tab.
- During runtime, you have the option of entering recipe data record values directly on the HMI device or importing them via a CSV file. You can also export the recipe data records to a CSV file.

## 5.5.4 Recipe application

### 5.5.4.1 Transfer of recipe data records

#### Introduction

Recipe data records can be transferred in Runtime between external data storage media, e.g. a flash memory, an HMI device and a controller.

#### Principle

The figure below shows how recipe data records can be transferred. You configure the appropriate functionality for transferring data records in the recipe view. In a recipe screen, you use the system functions provided for this purpose.

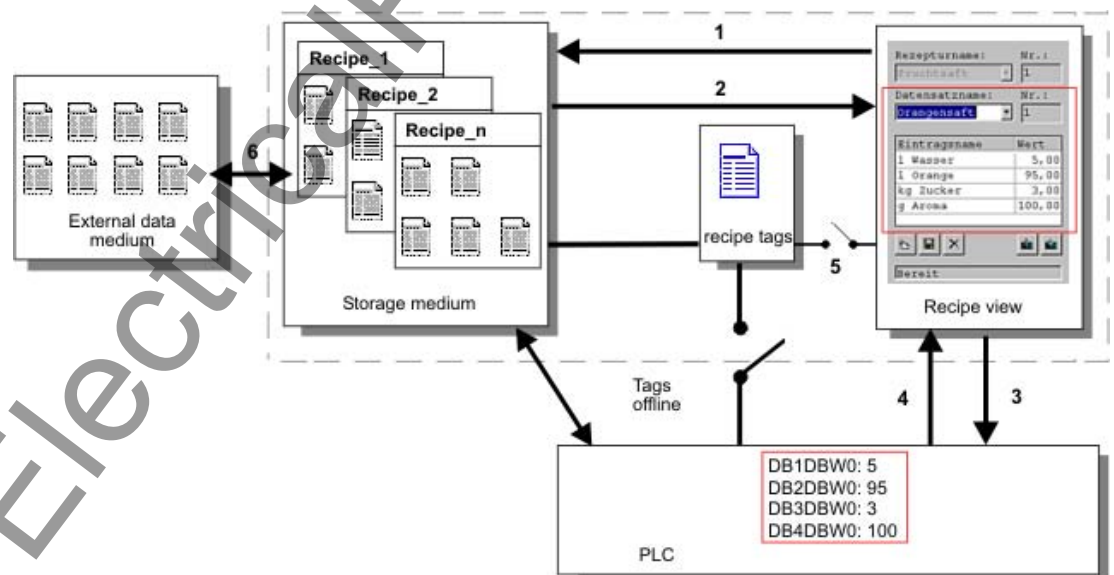

The HMI device stores recipe data records on a storage medium such as a flash memory device or hard disk. You can edit a recipe data record in a recipe view or recipe screen on the HMI device display.

(1) Save: Values you change on the recipe view or recipe screen are written to the recipe data record on the storage medium by executing the "Save" function.

(2) Load: The "Load" function is used to update the values of recipe tags shown on the recipe screen with the values of the recipe data record of the storage medium. The function overwrites any values changed on the recipe screen. The "Load" function is executed for the Recipe view when the data record is selected again.

(3) Write to controller: The values deltas of the recipe view and recipe screen are downloaded to the PLC by calling the "Write to controller" function.

(4) Read from controller: Call the "Read from controller" function to update the indicated values of the recipe view and recipe screen with the controller values. The function overwrites any data changed on the recipe view or screen.

(5) Synchronization with control: In your configuration, you can decide to synchronize the values in the recipe view with the values of the recipe tags by setting the "Synchronization with control" function. After this synchronization, both the recipe tags and the recipe view contain the current updated values. When the "Variables offline" setting is disabled for the recipe, the current values are also applied in the controller.

(6) Import, Export: A data record can be exported to an external data carrier in order to process it in MS Excel, for example. The data record is there stored in \*.csv format.

### 5.5.4.2 Configuration of recipes

#### Introduction

You configure recipes according to your intended application. To write a value to a recipe data record on your HMI device without disturbing the current process, you need configuration settings other than those required for assigning parameters to a machine.

#### Principle

In the configuration settings of a recipe, you specify the behavior of the tags you are using in the recipe. The figure below shows the basic differences when working with recipe data records.

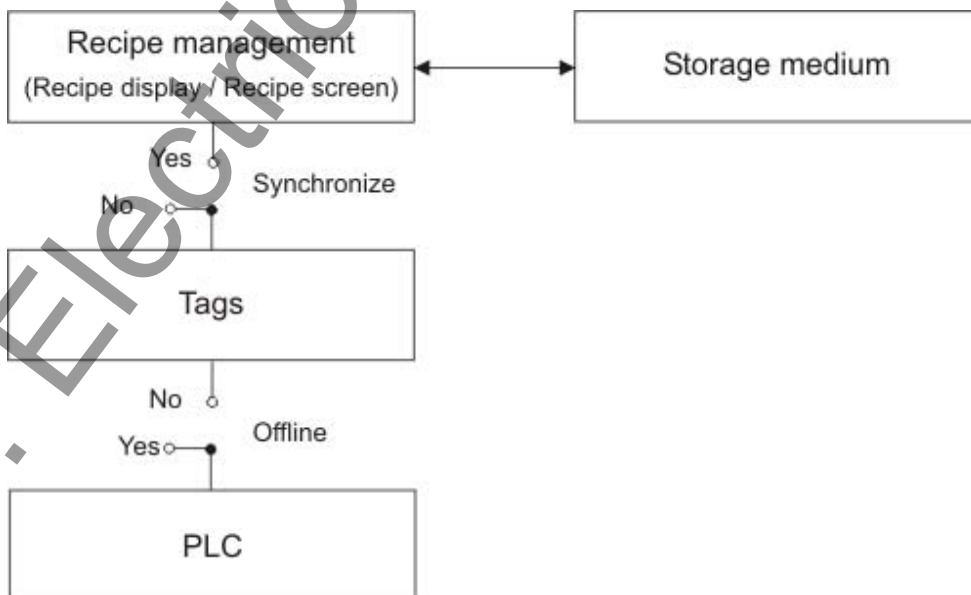

These configuration settings are made under "Settings" in the property view:



### Configuration 1: Recipe without "Synchronize tags"

Data of a data record that has been read are only displayed and can only be edited in the recipe view. Using these same tags outside of the recipe view does not affect their values.

### Configuration 2: Recipe with "Synchronize tags" and with "Tags offline"

The "Synchronize tags" option is used to specify that the data of a data record read from the controller or storage medium are to be written to or read from the tags you have configured for the recipe.

The "Offline" option ensures that the input data are written to the tags without being transferred directly to the controller.

### Configuration 3: Recipe with "Synchronize tags" and without "Tags offline"

The "Synchronize tags" option is used to specify that the data of a data record read from the controller or storage medium are to be written to or read from the tags you have configured for the recipe.

The input or read data are transferred immediately to the controller:

### Synchronization with the controller

In the case of synchronous transfer, both the controller and the HMI device set status bits in the shared data compartment. You can use this mechanism to prevent uncontrolled overwriting of data in either direction in your control program. You define the address range of the data compartment separately for each controller on the "Range pointer" tab in the "Connections" editor.

Applications for synchronous transfer of recipe data records:

- The controller is the "active partner" for the transfer of recipe data records.
- The controller evaluates the data containing the recipe number and name, as well as the recipe data record number and name.
- Triggering the transfer of data records by means of system function or PLC job, e.g. with the system functions "SetDataRecordToPLC" and "GetDataRecordFromPLC", or with the PLC jobs "Set\_Data\_Record\_To\_PLC" and "Get\_Data\_Record\_From\_PLC."

In order to synchronize transfer of data records between the HMI device and the controller, the following requirements must be met during configuration:

- The "Data mailbox" range pointer is located under "Range pointers" in the project view.
- The controller with which the HMI device synchronizes the data record transfer is specified in the recipe properties.

### 5.5.4.3 Scenario: Entering recipe data records in Runtime

#### Objective

You want to enter production data on the HMI device without disturbing the process that is currently underway. Therefore, the production data should not be transferred to the PLC.

#### Sequence

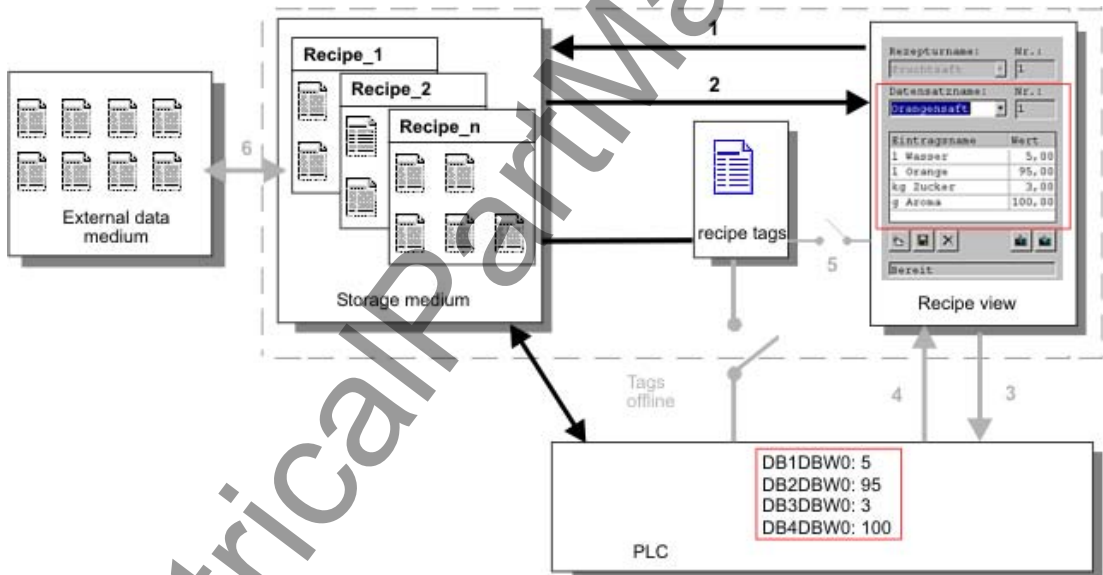

You enter the production data in the recipe view or the recipe screen, assign a recipe data record name, and save the new recipe data record on the storage medium of the HMI device.

### Configuration in WinCC flexible

You configure the recipe along with the associated tags.

Synchronization with the recipe tags is not necessary, because production data (tags) are not intended to be transferred to the PLC. Make the following settings for the recipe in the property view:



Depending on the extent of the recipe, you either configure a recipe view or create a recipe screen.

#### 5.5.4.4 Scenario: Manual production sequence

##### Objective

The production data are to be requested by the PLC according to the work piece to be processed and displayed on the HMI device for inspection. You want to be able to correct the transferred production data online, if necessary.

##### Sequence

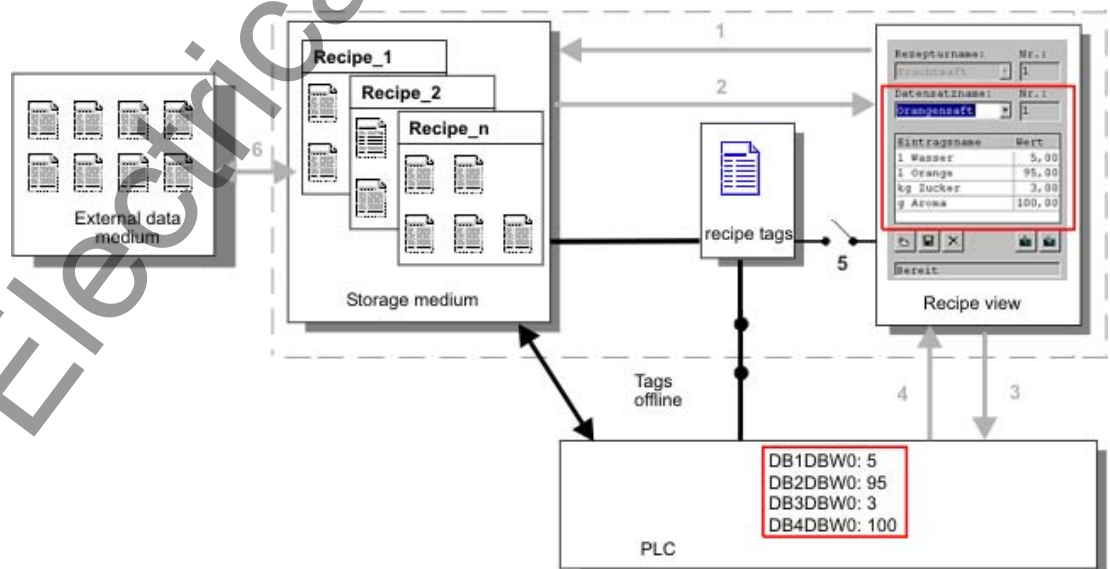

A reading device connected to the PLC reads a bar code on the work piece to be processed. The recipe data record names correspond to the respective bar code names. This will enable the PLC to load the necessary recipe data record from the storage medium of the HMI device. The recipe data record is displayed for inspection. Changes are transferred immediately to the PLC.

**Configuration in WinCC flexible**

You configure the recipe along with the associated tags.

Production data are to be transferred to the PLC, so it is necessary to synchronize with the PLC to prevent the data from accidentally overwriting each other. The tags are to be transferred to the PLC. Make the following settings for the recipe in the property view:

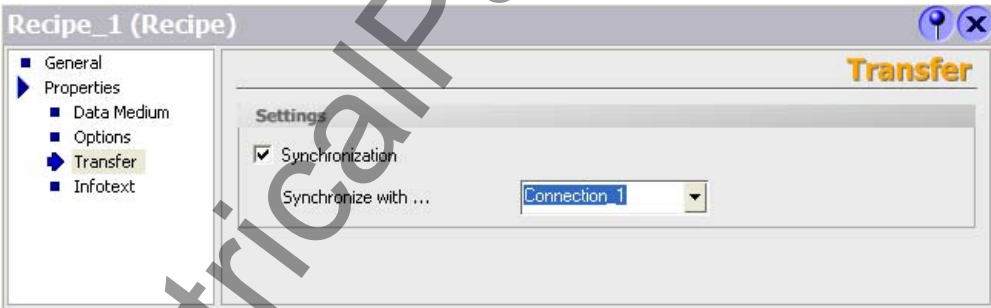
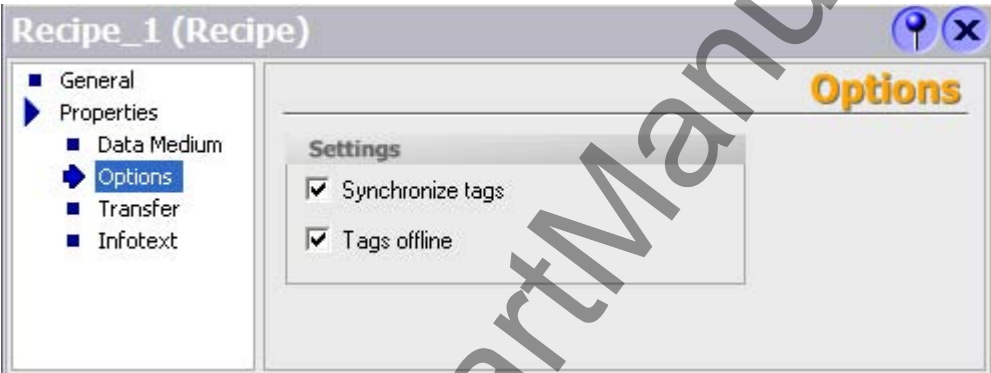

Depending on the extent of the recipe, you either configure a recipe view or create a recipe screen.

### 5.5.4.5 Scenario: Automatic production sequence

#### Objective

You want production to be executed automatically. The production data should be transferred directly to the PLC either from the data storage medium in the HMI device or from an external data storage medium. The production data do not have to be displayed.

#### Sequence

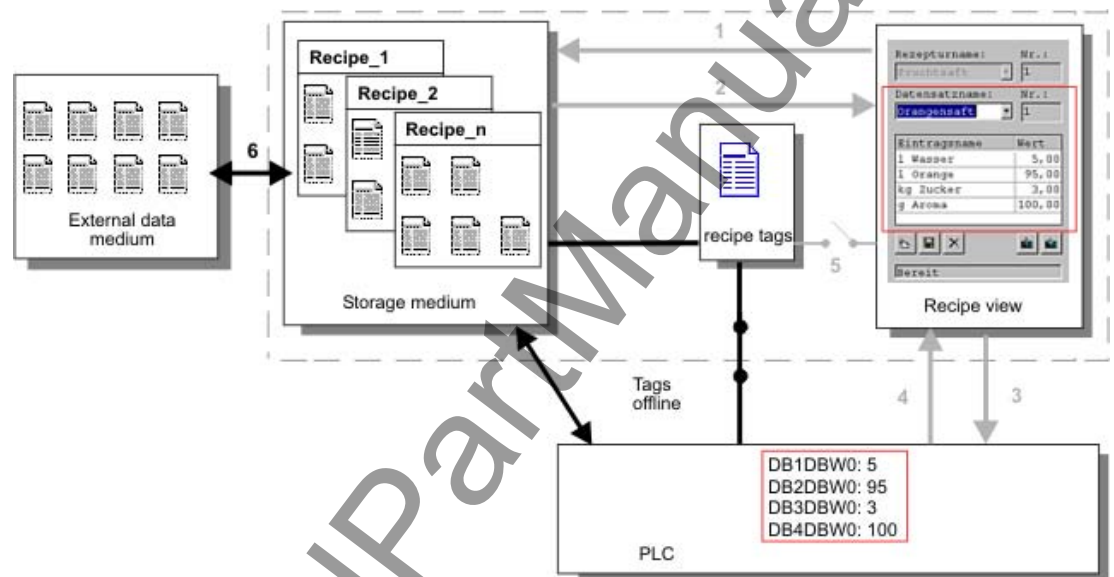

Production can be controlled using one or more "Scripts", which transfer production data records automatically to the PLC. The sequence can be checked using the return values of the utilized functions.

#### Configuration in WinCC flexible

You can implement the automatic production sequence with available system functions. The "ImportDataRecords" system function loads data records from a CSV file to the data medium. The "SetDataRecordTagsToPLC" system function transfers a data record from the data storage medium to the PLC.

## 5.5.5 Displaying recipes

### 5.5.5.1 Viewing and editing recipes in Runtime

#### Introduction

The WinCC flexible ES offers you two configuration options of viewing and editing recipes and their corresponding data records in Runtime on the HMI device:

- Recipes view
- Recipe screen

#### Recipes view

The recipe view is a screen object that is configured in the "Screens" editor. For example, you can specify what operating function the recipe view will have in Runtime:

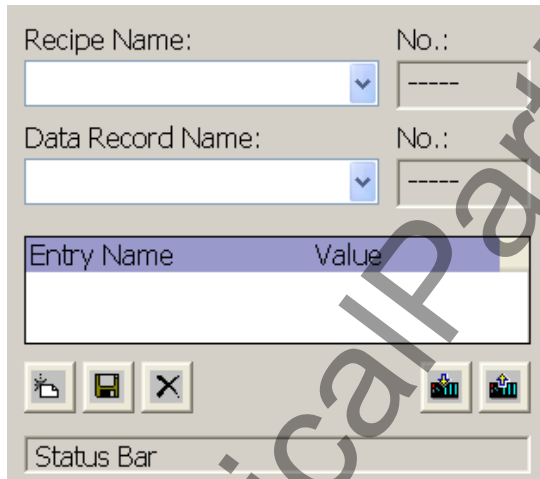

The recipe view shows recipe data records in tabular form. The Recipe view is particularly useful if data records are small in size or only a few values are to be modified.

### Simple recipe view

On HMI devices which have a display smaller than 6" (e.g. OP 77B), the simple Recipe view is used to display and edit recipes.

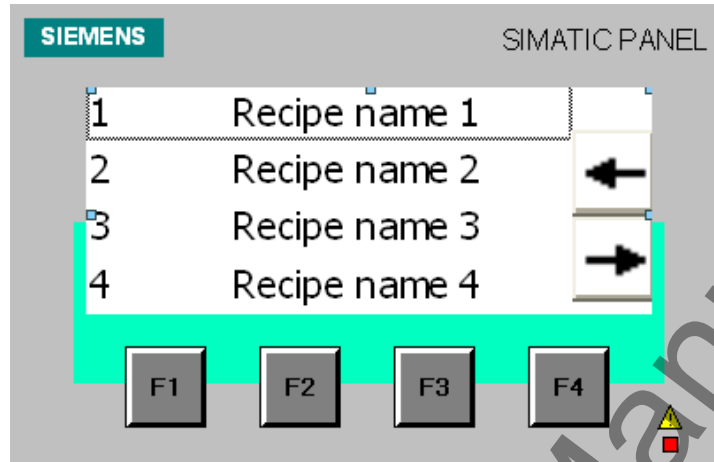

The simple recipe view consists of three areas:

- Recipe selection
- RecipeDataRecordSelection
- Recipe entries

In the simple recipe view, each area is shown separately on the HMI device. The simple recipe view always begins with the recipe selection.

### Recipe screen

A recipe screen is a process screen with a customized input screen form that you create by setting up input/output fields and other screen objects in the "Screens" editor. This makes it possible for you to input parameter data in the context of machine visualization. The I/O fields for a recipe can be distributed over multiple recipe screens, which allows you a topical organization of recipe elements. The operating functions for the recipe screens must be configured explicitly in the process screens.

Litre Water	50	Recipe name	No.:
Litre Concentrate	50	Orange	1
Kilo Sugar	30	Data record name	No.:
Gram Aroma	50	Nectar	2
		Save	Data to PLS
		Load	Data from PLS

### 5.5.5.2 Behavior of the recipe view in Runtime

#### Screen change

If you change to another screen and have not yet saved changes to the recipe data in the recipe view, you will be prompted to save the recipe data. The recipe name and the name of the recipe record are displayed to show which recipe data have not been saved yet.

If you change to a process screen that contains a recipe view with loaded recipe data, the recipe data will be automatically updated.

#### Operating the recipe view with softkeys

The Recipe view can be operated with function keys, e.g. when the HMI device does not have touch functionality. System functions allow you to assign functions such as "Save data record" to the function keys of the HMI device.

#### Display after import of recipe data

If you open the recipe view during the import of recipe data, only the recipe data that is already completely imported will be displayed. The recipe view is not automatically updated with a data import. In order to have a complete view of all recipe data, only open the recipe view after the system alarm informs you that the import of recipe data was successful. Alternatively, update the recipe view after successful completion of the import procedure.

## 5.5.6 Recipe data record administration

### 5.5.6.1 Recipe data record administration

#### Recipe data record administration

In Runtime you can, based on the configuration

- Create new recipe data records
- Copy recipe data records
- Edit recipe data records
- Delete recipe data records

That is, you can either edit recipe data records in the recipe view or screen, or import recipe data records from a CSV file.

### Creating new recipe records

1. Select the recipe on the HMI device in which you want to create a new recipe data record.
2. Use the "Add data record" button in the recipe view or the corresponding button on the HMI device that has this function.  

A new data record with the next available number will be created. If you change the new data record number of an existing data record number, the data record is overwritten.
3. Enter a name for the recipe data records.
4. Enter the values for the recipe data records.  

The configuration data may already contain default values for the recipe data record.
5. Use the "Save" button in the recipe view or the corresponding button on the HMI device that has this function.

### Result

The new recipe data records will be saved to the selected recipe. If the recipe data records already exists, a system alarm will be output to the screen.

### Copying a recipe data record

You copy a recipe record by saving it under a new name.

1. Select the recipe on the HMI device in which you want to edit an existing recipe data record.
2. Select the recipe data record that you want to edit on the HMI device.
3. Assign a new name to the recipe data record.  

As soon as you close the "Recipe data record" input field, the next free recipe data record number will be automatically assigned to the recipe data record. You may change the recipe data record number.
4. Use the "Save" button in the recipe view or the corresponding button on the HMI device that has this function.

### Result

The recipe data record is stored under the new name.

### Modify recipe record

1. Select the recipe on the HMI device in which you want to edit an existing recipe data record.
2. Select the recipe data record that you want to edit on the HMI device.
3. Replace the old values with new ones.
4. Use the "Save" button in the recipe view or the corresponding button on the HMI device that has this function.

## Result

The modified values are applied to the recipe data record.

## Delete recipe data record

1. Select the recipe on the HMI device in which you want to delete an existing recipe data record.
2. Select the recipe data record that you want to delete on the HMI device.
3. On the recipe view, select "Delete data record", or use the relevant HMI device button which is assigned this function.

## Result

The recipe data record is deleted from the data medium of the HMI device.

### 5.5.6.2 Synchronizing a recipe data record

#### Introduction

In the current project, differences between the indicated values and the actual values of the recipe tags may arise as a result of data input in recipe views or modification of recipe tags. Depending on the configuration, you can synchronize the values displayed in the recipe view with the recipe tags and values of the PLC. This synchronization is performed for each one of the recipe tags contained in the recipe data record.

#### Requirement

A recipe data record is displayed in the recipe view. The value of recipe tags can be changed, for example by teach-ins.

#### Procedure

1. Use the "Synchronization with control" button in the recipe view or the corresponding button that has this function.

#### Result

- The system always updates the current value of the recipe view with the up-to-date recipe tag value.
- When the value shown in the recipe view is more recent than the current recipe tag value, the system writes this value to the recipe tag.

### 5.5.6.3 Read recipe data record from PLC

#### Introduction

You can read values from the PLC and write them to a recipe data record. For example, you can do this in machine teach-in mode in order to save the positioning data of axes as a recipe data record.

The read values are written to the recipe record that is currently displayed on the HMI device.

#### Procedure

1. Select the recipe on the HMI device.
2. On the HMI device, select the recipe data record of which you want to fetch the values from the PLC.
3. Use the "Read from PLC" button in the recipe view or the corresponding button on the HMI device that has this function.
4. Use the "Save" button in the recipe view or the corresponding button on the HMI device that has this function.

#### Result

The values are read from the PLC, visualized on the HMI device and saved to the recipe data record.

### 5.5.6.4 Transfer recipe record to PLC

#### Introduction

You can edit recipes offline or online.

- Offline: The data are transferred to the PLC after the relevant command is executed.
- Online: The data are transferred immediately to the PLC

In the recipe view, data are always edited offline. The configuration of the recipe screen determines whether the recipe data are edited offline or online.

When you edit data offline, you have to transfer the changed data to the PLC.

#### Procedure

1. Select the recipe on the HMI device.
2. On the HMI device, select the recipe data record of which you want to transfer the values to PLC.
3. Use the "Write to PLC" button in the recipe view or the corresponding button on the HMI device that has this function.

#### Result

The values of the recipe record are transferred to the PLC.

### 5.5.6.5 Exporting and importing recipe data records

#### Introduction

Based on your configuration, you can either export recipe data records to a CSV file for editing in MS Excel, for example, or import these from a CSV file. The extent to which you can influence these processes is determined by the project configuration. Various input fields may be configured on the user interface:

- Input of the path to the CSV file
- Selection of the recipe data records for export
- Overwriting an existing CSV file

#### Export recipe data record

##### Requirements

Export functions are configured.

##### Procedure

1. Customize the export settings on the user interface of the HMI device.
2. Press the button or the key on the HMI device configured with the "Export recipe records" function.

##### Result

The recipe data record are exported to a CSV file.

---

##### Note

New data records created in runtime can be exported to an external file.

---

#### Importing recipe records

##### Requirements

Import functions are configured.

##### Procedure

1. Customize the import settings on the user interface of the HMI device.
2. Use the button or the key on the HMI device which is assigned the "Import recipe records" function.

## Result

The recipe data records are imported. If the structure of the CSV file is different from the recipe structure, deviations are treated as follows:

- Any additional values in the CSV file will be rejected.
- If the CSV file contains values of the wrong data type, the configured default value is set in the recipe record.

Example:

The CSV file contains values that show the tank contents and were input as floating point numbers. However, the corresponding recipe tag expects an integer value. In this case, the system discards the imported value and uses the configured default.

- The system also applies the configured default value to the recipe data record if the CSV file contains an insufficient number of values.

### 5.5.6.6 Reactions to modifications of the recipe structure

#### Introduction

Engineering for the purpose of machine retrofitting may also influence the recipe structure. Previously created recipe data records can nevertheless continue to be used.

#### Effects

If the structure of the recipe record is different from the defined address ranges in the PLC, deviations are handled as follows:

- Any additional values in the recipe record will be rejected.
- If the recipe record contains values of the incorrect data type, the default will be used in the recipe record.

Example: The recipe record contains values that show the tank contents and were input as floating point numbers. However, the corresponding recipe tag expects an integer value. In this case, the transferred value is rejected and the default value is used.

The system also applies the default value to the recipe data record, if the recipe data record contains an insufficient number of values.

---

#### Caution

When a tag is renamed, the assignment is lost.

---

5.5.7 Example

5.5.7.1 Example: Creating a recipe

Task

In this example, you create three recipes for a fruit juice mixing machine. The fruit juice mixing machine is to be used to produce orange, apple, and tropical fruit flavors, based on mixing ratios for fruit drinks, nectar, and juice.

Settings

The settings relate to an HMI device which is connected to a SIMATIC S7-300 or SIMATIC S7-400 via MPI.

In this example, you need the following tags, flags, recipes, and recipe data record values:

Tags:

Name	PLC connection	Address	Type
Liter water	yes	DB 120, DBW 0	Integer
Liter concentrate	yes	DB 120, DBW 4	Integer
Kilo sugar	yes	DB 120, DBW 8	Integer
Gram flavoring	yes	DB 120, DBW 12	Integer

Flag:

Name	Address
Data set	DB 100, DBW 0

Recipe (basic settings):

Recipe element	Associated tag
Liter water	Liter water
Liter concentrate	Liter concentrate
Kilo sugar	Kilo sugar
Gram flavoring	Gram flavoring

Recipe data record values:

Data record name	Liter water	Liter concentrate	Kilo sugar	Gram flavoring
Fruit drink	30	70	45	600
Nectar	50	50	10	300
Juice	5	95	3	100

## Procedure

1. Create the following tags with the settings indicated earlier: Liter water, Liter concentrate, Kilo sugar and Gram flavoring.
2. Create the orange, apple, and tropical fruit recipes with the settings indicated above.

Name  Display name  Number  Version

**Elements** | Data records

	Name	Display name	Tag	Default value	Decimal point	Infotext
☰	Water	Water	LitreWater	0	0	Water content in liters
☰	Concentrate	Concentrate	LitreConcentrate	0	0	Concentrate content in liters
☰	Sugar	Sugar	KiloSugar	0	0	Sugar content in kilograms
☰	Aroma	Aroma	GrammAroma	0	0	aroma content in grams

3. Configure each recipe in such a way that you can edit the recipe data records on a recipe screen. The values of the recipe tags should not be transferred automatically to the PLC.
4. Create the data records indicated above in each recipe. Enter the values indicated above in each of the data records.

**Elements** | **Data records**

	Name	Display name	Number	Water	Concentrate	Sugar	Aroma
☰	Beverage	Beverage	1	30	70	45	600
☰	Nektar	Nektar	2	50	50	10	300
☰	Juice	Juice	3	5	95	3	100

## Result

The orange, apple, and tropical fruit flavor recipes have been created. In the "Configure recipe screen" example, you create a recipe screen in which you create an individual input screen form.

5.5.7.2 Example: Configuring a recipe screen

Task

In this example, you create a recipe screen for the visualization of values of the fruit juice mixing machine. You use a recipe view to select the recipes and their associated recipe data records. You should be able to load and save the values of the recipe data records, and transfer them to and read them from the PLC.

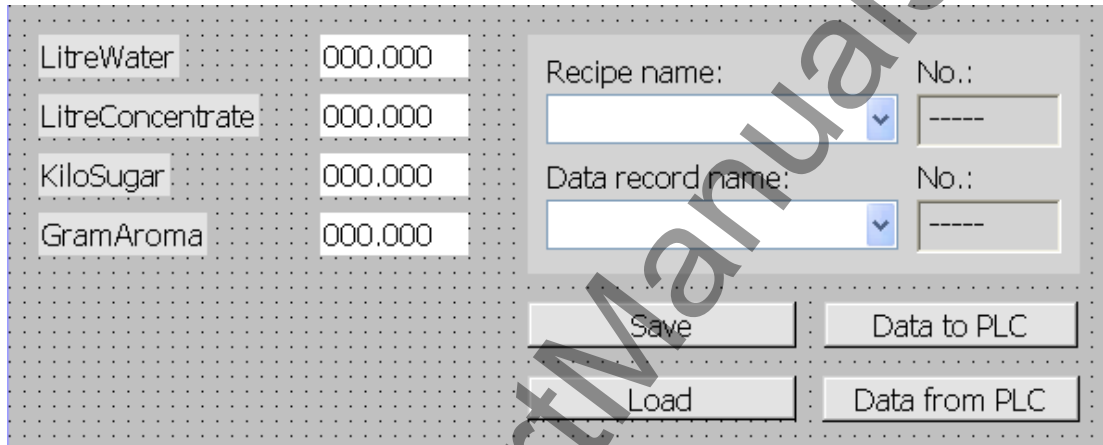

Requirements

The "Creating a recipe" sample application has been carried out.  
 The "Fruit juice mixing machine" process screen has been created and is opened.

Settings

In this example, you need the following tags and buttons with the indicated settings:

Tags:

Name	PLC connection	Type
RecipeNumber	NO	Integer
Data record number	NO	Integer

Buttons:

Labeling	Configured event	System function
Downloading	Press	LoadDataRecord
Save	Press	SaveDataRecord
Data to PLC	Press	SetDataRecordTagsToPLC
Data from the PLC	Press	GetDataRecordTagsFromPLC

## Procedure

1. Drag-and-drop the "Liter water", "Liter concentrate", "Kilo sugar", and "Gram flavoring" tags from the object view to the "Fruit juice mixing machine" process screen.  
Four I/O fields are created and linked by the specified tags.
2. Configure a recipe view containing only the drop-down lists for the recipe name and data record name. Link the recipe view to the "Recipe number" and "Data record number" (recipe data record number) tags in the "General" group in the property view.
3. Assign the settings described above to each one of the four buttons. Transfer each "Recipe number" and "Data record number" tag as a parameter for the recipe number and recipe data record number.

## Result

In Runtime, you can select the recipe and the associated recipe data record from the recipe view. Click "Load" to load the recipe data record values and display these in the configured I/O fields. Click "To PLC" to write the recipe data record values to the associated tags and to transfer the recipe data record values to the PLC.

## 5.6 Reports in Runtime

### Overview

Logs are used to document process data and completed production cycles. The log content and layout are specified in the project, as is the event triggering the printout of the report.

For example, a log can be configured for output at the end of a shift, in order to record downtimes. A log can also be configured for the purpose of the documentation of product testing or quality inspections (ISO 9000).

### Output

Reports are printed in Runtime either automatically, e.g. by means of a scheduler, or manually, e.g. by means of a softkey.

### Printing reports

Reports are output to the printer in graphic mode. The use of a serial printer is not recommended because of the accumulated data volume.

For proper output, the printer must support the paper format and page layout of the report.

---

#### Note

The value of a tag in the report is read and output at the moment of printing. A substantial time may elapse between printing out the first and the last page of a report consisting of several pages. This may lead to the same tag on the last page being output with a different value from that on the first page.

---

## 5.7 System functions and scripts in Runtime

### Application

System functions and scripts are used in Runtime for the following purposes:

- To control the process
- To utilize the properties of the HMI device
- To make system settings online on the HMI device

In WinCC flexible, each system function and each script is linked to an object, such as a button, field or screen, and an event. As soon as the event occurs, the system function is triggered.

### System functions

System functions are predefined functions that are used to implement many tasks in Runtime, such as:

- calculations, e.g. increasing a tag value by a specific or variable amount
- Logging function, e.g. starting a process value log
- Settings, e.g. changing the PLC or setting a bit in the PLC.
- Alarms, e.g. after a different user logs on.

### Scripts

Scripts may also be included in the project for specific applications which may require additional functions. For the creation of scripts, WinCC flexible provides an interface to Microsoft Visual Basic Script (VBScript). This allows you to integrate additional functions, such as:

- conversion of values, e.g. between different physical units (temperatures)
- Automation of production sequences

A script can control a production sequence by transferring production data to a PLC. The status can be checked based on the returned values, and appropriate measures can thus be initiated.

### Events

The object and the selected function determine what events can be defined as triggers for executing a system function.

For example, the events "Change Value", "Below Lower Limit" and "Above Upper Limit" are associated with the "Tag" object. The "Loaded" and "Cleared" events are associated with the "Screen" object.

## 5.8 Security in Runtime

### Overview

The configuration engineer can protect the operation of a project by implementing a security system. The security system is based on authorizations, user groups and users.

The security system of the HMI device is based on authorizations, user groups and users.

If operator control objects protected by a password are operated, the HMI device requests the entry of a password. A login screen is displayed in which you enter your user name and password. After logging in, you can operate the operator control objects for which you have the necessary authorizations.

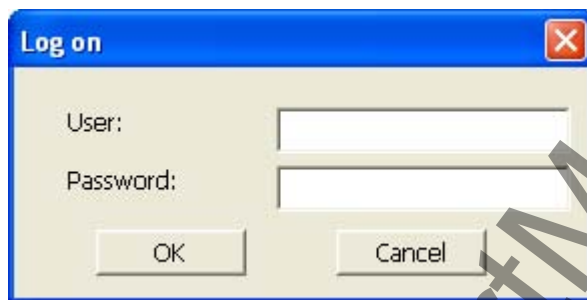

The login dialog can be set up by the configuration engineer via an individual operator control object.

In the same way, the configuration engineer can set up an operator control object to log off. After logging off, objects assigned password protection can no longer be operated; to do so, log in again.

### User groups and authorizations

Project-specific user groups are created by the configuration engineer. The "Administrators" group is included in all projects by default. User groups are assigned authorizations. The authorization required for an operation is specifically defined for each individual object and function in the project.

### Users

Each user is assigned to exactly one user group.

Users can be created as follows:

- By the configuration engineer during configuration
- By the administrator on the HMI device
- By a user with "Administration" authorization to the user administration on the HMI device

### Passwords

Only registered users may log on to Runtime by entering their user name and password. The passwords can be assigned by the configuring engineer, by the "Admin" user (or by users who have "Administration" authorization), or by the user himself.

The authorizations of a user after logging in depends on the user group to the user is assigned.

After the project is transferred, only the administrator is authorized to create user accounts, make user group assignments, and change passwords. Any other users who are subsequently assigned to the "Administrator" group by the administrator may also carry out these tasks.

The user data is encrypted and saved on the HMI device to protect it from loss due to power failure.

---

**Note**

Depending on the transfer settings, changes to the user data are overwritten when the project is transferred again.

---

**Logoff times**

A logoff time is specified in the system for each user. If the time between any two user actions, e.g. entering a value or changing screens, exceeds this logoff time, the user is automatically logged off. The user must then log in again to continue to operate objects assigned password protection.

**User view**

Use the User view to display the users on the HMI device.

User	Password	Group	Logoff time
Admin	*****	Group (9)	5
PLC User	*****	Group (1)	5
User 1	*****	Group (1)	5

**Export and import**

The users, passwords, group assignments and logoff times established on the HMI device can be exported and then imported on a different HMI device. This prevents you having to enter all of the data again on another HMI device.

---

**Notice**

When importing, the currently valid user data is overwritten. The imported user data and passwords are valid immediately.

---

## 5.9 Further operating options in Runtime

### Print functions

Print functions available in online mode: :

- Hardcopy

You can print the content of the currently displayed screen if you utilize the "Print screen" system function in your configuration.

- Printing alarms

Each alarm event that occurs (incoming, outgoing, acknowledgment) is also sent to a printer.

- Printing reports

### LED control

The light-emitting diodes (LED) in the function keys of the SIMATIC HMI devices can be controlled from the PLC. For example, an illuminated or flashing LED can signal the operator to press a specific function key on the device.

www.ElectricalPartManuals.com

# Operating a project in Runtime

## 6.1 Basics for operation in Runtime

### 6.1.1 Introduction

#### Introduction

Operation of a process depends on how the project was created and the options available on the HMI device. This chapter contains general information on the settings for the Runtime software and the operation of predefined screen objects.

Screen objects provide general system functions. Screen objects may have been used and configured in screens of the project.

WinCC flexible Runtime can be operated with the keyboard, mouse or touch screen, depending on the HMI device used.

#### Multiple key operation

If you are using a key device, you can press two function keys at once.



---

#### Caution

When you use a key device, you may not press more than two function keys simultaneously.

If you use a touch device, standard PC or a panel PC, you may only press one function key or button at a time.

In both cases, pressing too many keys may be inadvertently trigger actions.

---

#### Change language

WinCC flexible allows you to configure a multilingual project. Up to five of these project languages can be loaded simultaneously onto the HMI device.

You can switch between the individual languages in Runtime, provided this function has been configured. When languages are switched, the language-dependent objects such as texts or formats are displayed in another language.

Objects that may contain language-relevant texts include:

- Alarms
- Screens
- Text lists
- Operator notes
- Recipes
- Date/time
- Decimal symbol
- Static texts

### Pictograms

HMI devices with integrated keyboard (e.g. Panel PC 670) may be configured with pictograms on the bottom and on the left / right screen margins.

Pictograms are used to clarify the screen-specific functions of the function keys. Use the associated function key to trigger the function symbolized by the pictogram.

## 6.1.2 Operation with mouse and keyboard

### Operation with the keyboard

The navigation options listed in the table can be used for keyboard operations in a screen.

Navigation	PC	SIMATIC Panel PC
Next field right/left	<Shift+Right> / <Shift+Left>	<Right> / <Left>
Next field up/down	<Shift+Down> / <Shift+Up>	<Down> / <Up>
To the right/left in the field	<Right> / <Left>	<Shift+Right> / <Shift+Left>

The other keys have identical functions on the PC and the SIMATIC Panel PC:

Key	Function
<Enter>	Applies a value (e.g. in unmarked input fields) or opens a selection list. If the I/O field is marked (highlighted in color), WinCC flexible Runtime will switch to the special editing mode. Now, only one character will be marked in the field. Use the cursor keys <Up>/<Down> to scroll through a character table. Use the cursor keys Right/Left to move the cursor to the next or previous entry position. Press <Enter> or <Esc> to exit from the entry mode. The characters entered up to this point will be either applied or discarded.
<Esc>	Interrupts the input.
<Tab>	Selects the next available screen object in the configured tab sequence.
<Shift+Tab>	Selects the previously available screen object in the configured tab sequence.

Key	Function
<F1> -... <F12>, <Shift+F1>, ..., <Shift+F12>	On the PC: Triggers a function, e.g. screen selection.
<F1>, ... or <S1>, ... or <K1>, ...	On the SIMATIC Panel PC: triggers a global or local function.



### Caution

If you press a function key after a screen change, the associated function in the new screen may be triggered before the new screen is fully displayed.

### Controlling Windows with the keyboard

You may also use the keyboard to control the operating system of your HMI device. See your Windows manual for detailed information. The most important key combinations for SIMATIC Panel PCs are listed in the following table.

Navigation	HMI device
Open start menu	<Ctrl+Esc>
Show the shortcut menu of the selected element	<Shift+F10>
Select all	<Ctrl+A>
Display properties of the selected element	<Ctrl+Enter>
Explorer:	
Change folder	<F4>
Change display areas	<F6>
Enable menu bar	<F10>
Dialogs:	
Go to next field	<Tab>
Back to previous field	<Shift+Tab>
Open next tab	<Ctrl+Tab>
Open previous tab	<Ctrl+Shift+Tab>

### Operation with the mouse

A lightning symbol attached to the mouse pointer indicates that the screen object, for example a switch, may be operated with the mouse.



### 6.1.3 Operating the touch screen device

#### 6.1.3.1 Operating touch objects

##### Operation

Touch objects represent touch-sensitive operator control objects on the HMI screen such as buttons, I/O fields and alarm windows. Touch objects are basically operated in the same way as conventional keys. You operate touch objects by touching them with your finger.



---

**Caution**

Never touch more than one object on the screen. Do not touch several touch objects simultaneously. Otherwise, you can trigger an unintended action.

---

**Caution**

Do not use any pointed or sharp objects when operating the touch screen in order to avoid damage to its plastic screen membrane.

---

##### Direct keys

With a PROFIBUS DP connection, it is also possible to configure buttons for operation as direct keys in order to allow rapid operator inputs using keys. For example, jog mode requires rapid operator inputs using keys.

PROFIBUS-DP direct keys place bits directly from the HMI device in the I/O area of a SIMATIC S7.

---

**Note**

Direct keys can only be triggered by touch and not by a mouse click from an connected external USB mouse.

---

**Note**

With touch operation, direct keys are triggered independent of any configured password protection.

---

**Notice**

Direct keys are still active when the HMI device is in "offline" mode.

---

##### Operation feedback

The HMI device responds with visual and auditory feedback as soon as it detects the operation of a touch object. This feedback is independent of any communication with the PLC. Therefore, this feedback does not indicate whether the relevant action is actually executed or not.

### Acoustic acknowledgement

The HMI device outputs a beep to signal operation of a touch object. You can disable this beep.

### Optical feedback

The type of optical feedback depends on the operator control object:

- Buttons

The HMI outputs different views of the "Touched" and "Untouched" states, provided the configuration engineer has configured a 3D effect:



Touched      Untouched

The configuring engineer defines the appearance of a selected field (line width and color for the focus).

- Invisible buttons

The focus of hidden buttons is not marked after selection (focus width value is 0, default). In Runtime, the outline of a touched button is indicated as a line when you modify the value for the focus width in the configuration. This outline remains visible until the focus is set on another operating object.

- I/O fields

After you touch an I/O field, a screen keyboard appears as feedback.

### Operating screen objects with buttons

Screen objects with predefined buttons can also be operated with external buttons. To do so, the corresponding system functions must have been linked to this button by the configuring engineer.

In WinCC flexible, these system functions are compiled in the "Keyboard actions for screen objects" group.

#### 6.1.3.2 Input of values

##### Screen keyboard

The HMI device automatically opens the screen keyboard when you touch an input object such as an I/O field. This screen keyboard is also displayed to input of passwords for access to protected functions. The keyboard is automatically hidden again when input is complete.

Based on the configuration of the input object, the HMI device shows a screen keyboard only for the input of numeric or alphanumeric values.

The screen keyboard is activated by selecting an input object in runtime.

### 6.1.3.3 Entering alphanumeric values

#### Alphanumeric screen keyboard

The HMI device automatically opens an alphanumeric on-screen keyboard for inputting character strings and numeric values in hexadecimal format when you touch an input object on the touch screen. The keyboard is automatically hidden again when input is complete.

The <Help> key is only active if an operator note has been programmed for the input object.



#### Keyboard layers

The alphanumeric keyboard is organized in several layers:

- Standard layer (see the figure)
- <Shift> layer
- <Alt Gr> layer
- <Shift+Alt Gr> layer

The <Alt Gr> and <Shift+Alt Gr> layers are used for the input of special characters.

#### Procedure

You enter alphanumeric values character-by-character using the on-screen keyboard buttons. Confirm the input value with <Enter>, or cancel it with <Esc>. Both actions close the screen keyboard.

### 6.1.3.4 Entering numeric values

#### Numerical screen keyboard

The HMI device automatically opens the numerical touch screen keyboard for entering numerical values when you touch an I/O field. The keyboard is automatically hidden again when input is complete.

The <Help> button is only active if an operator note is configured for the I/O field.



#### Procedure

You enter the characters of numeric values using the screen keyboard buttons. Confirm the input value with <Enter>, or cancel it with <Esc>. Both actions close the screen keyboard.

#### Note

Limit values can be configured for numeric input fields. In this case, values are only accepted if they lie within configured limits. If you enter a value that is outside the configured limits, the system rejects this value and restores the original. The HMI outputs a system alarm to indicate this situation.

When you enter the first character, a tooltip appears showing the hi and lo limit values of the input field.

### 6.1.3.5 Calling the infotext

#### Purpose

The configuring engineer uses operator notes to provide additional information and operating instructions with respect to alarms, screens, and operable screen objects. For example, an operator note may contain information about the permissible range of values for an I/O field, or information on the cause and remedy of a fault in the event of an error alarm.

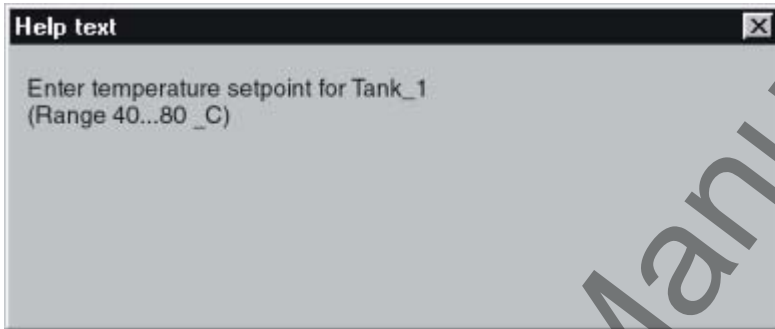

#### Help on messages

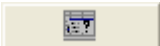
Press  in the alarm window or in the alarm view.

#### Help on input objects

Touch the <Help> button on the on-screen keyboard. This button is only available if you configured an operator note.

#### Help on the current screen

If, for example, the "ShowOperatorNote" function is assigned to a button in your configuration, you can call the configured operator note for the current screen by pressing this button.

#### Help on the focused screen object

Use the <Alt+H> key combination on the screen keyboard or on the connected USB keyboard to display the operator notes configured for the focused screen object.

---

#### Note

To view a new operator note, you first need to close the window showing the current operator note.

---

## 6.2 Operating graphic objects

### 6.2.1 Button

#### Application

A button is a virtual key on the screen of the HMI device that can have one or more functions.



#### Layout

The layout of the button depends on the button type.

- Button with text: The text shown on the button gives information regarding the status of the button.
- Button with graphic: The graphic shown on the button gives information regarding the status of the button.
- Invisible: The button is not visible in Runtime.

#### Operation

Depending on the configuration, you can operate the button in the following ways:

- Standard operation: Click the button.
- Event: An event is triggered when you operate the button, e.g. when you click it. The processing of a function list can be configured to the event.

#### Operation behavior

The operation may be followed with a optical feedback. However, note that the optical feedback only indicates a completed operation and not whether the configured functions were actually executed.

#### Operation with the mouse

1. Click on the button with the mouse pointer.

#### Operation with the keyboard

1. Press the <Tab> key until the button is selected.
2. Press <Enter> or <Space Bar>.

### Alternative operation

Depending on the configuration, you can also operate the button via the function keys.

### Operation behavior

The behavior depends on the configuration.

### Button with text, button with graphic

The operation may be followed with a optical feedback.

## 6.2.2 Switch

### Application

The switch is an operating element and display object with two states: "pressed" and "released." Switches can signal the state of a system component that cannot be seen from the HMI device, e.g. a motor. You can also change the state of that system component at the HMI device.

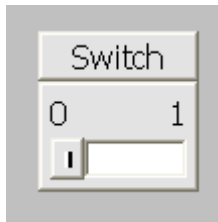

### Layout

The layout of the switch depends on the switch type.

- Switches: The switch has a slider. The position of this slider gives information about the status of the switch.
- Switch with text: The text shown on the switch gives information regarding the status of the switch.
- Switch with graphic: The graphic shown on the switch gives information regarding the status of the switch.

### Operation

Depending on the configuration, you can operate the switch in the following ways:

- Standard operation: Click the switch.
- Event: An event is triggered when you operate the switch, e.g. when you click it. The processing of a function list can be configured to the event.

### Operation behavior

A switch has two stable states: When you activate the switch, it changes to the other state. The switch retains this state until the next operation.

### Operation with the mouse

The behavior depends on the configuration.

### Switch with slider

1. Click on the slider.
2. While holding down the mouse button, drag the slider to the other position.

### Switch with text, switch with graphic

1. Click on the switch.

### Operation with the keyboard

1. Press the <Tab> key until the switch is selected.
2. Press <Enter> or <Space Bar>.

### Operation behavior

The behavior depends on the configuration.

### Switch with slider

The slider jumps to the other position.

### Switch with text, switch with graphic

The switch changes the status.

### 6.2.3 IO field

#### Application

You enter numeric or alphanumeric values in an I/O field. For example, a numeric value could be the number 80 as a temperature reference, an alphanumeric value could be the text "Service" as a user name.



#### Layout

The layout of the I/O field depends on the configuration:

- Numeric I/O field  
For input of numbers in decimal, hexadecimal or binary format.
- Alphanumeric I/O field  
For input of character strings.
- I/O field for date and time  
For input of calendar dates or time information. The format depends on the set configuration.
- I/O field for password entry  
For concealed entry of a password. The entered character string is displayed with placeholders (\*).

#### Operation

Depending on the configuration, you can operate the I/O field in the following ways:

- Standard operation: Enter a value in the I/O field.
- Event: An event is triggered when you operate the I/O field, e.g. when you activate it. The processing of a function list can be configured to the event.

#### Operation behavior

##### Limit value test of numerical values

Tags can be assigned limit values. The entered value is then only accepted if the value lies within the configured limits.

If an entered value exceeds a configured limit value, e.g. 80 with a limit value 78, the entered value is rejected. If an alarm window is configured, then a system alarm is displayed automatically.

### Decimal places for numerical values

If a numeric input field is configured with a specific number of decimal places, decimal places in excess of the limit are ignored. Empty decimal places are filled with "0" after the number is confirmed.

### Hidden input

With the hidden input, each character entered is displayed as an "\*" character. The data format of the value entered cannot be recognized.

### Operation with the mouse

1. Click in the I/O field with the mouse pointer.
2. Type in the relevant value.
3. Confirm your input with <Enter> or cancel it with <Esc>.

### Operation with the keyboard

1. Press the <Tab> key until the I/O field is selected.
2. Set the value.
3. Confirm your input with <Enter> or cancel it with <Esc>.

### Alternative operation with the keyboard

1. Press the <Tab> key until the I/O field is selected.
2. Press <Return>. The object changes to the specific editing mode. Now, only one character will be marked in the field.
3. Use the <Up>/<Down> cursor keys to scroll through a character table.
4. Use the <Right>/<Left> cursor keys to move the cursor to the next or previous input position.
5. Confirm your input with <Enter> or cancel it with <Esc>.

## 6.2.4 Graphic I/O field

### Application

A graphic I/O field can have the following Runtime functions:

- Output of graphic list entries
- Combined entry and output

Example of its use as output field:

To indicate the Runtime status of a valve, the graphic I/O field outputs the image of a closed or open valve.

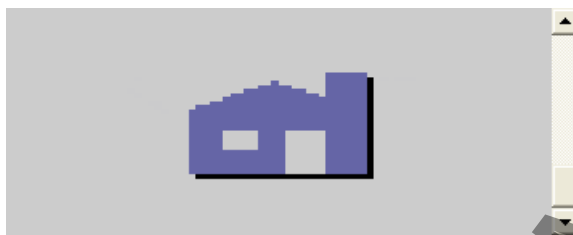

### Operation

Depending on the configuration, you can operate the graphic I/O field in the following ways:

- Standard operation: Select an entry from the graphic list.
- Event: An event is triggered when you operate the graphic I/O field, e.g. when you activate it. The processing of a function list can be configured to the event.

### Operation behavior

If the graphic I/O field displays a cactus image, you have not defined a graphic to be output for a specific value in your project.

The contents of the graphic I/O field change color to show that it is now activated.

### Operation with the mouse

1. Click on the graphic I/O field. The selection list opens.
2. Click on the scroll bar with the mouse pointer. Move the scroll bar in the desired direction while holding down the left mouse button.
3. Select the desired entry. The selection list is closed and the entry is displayed.

### Operation with the keyboard

1. Press the <Tab> key until the graphic I/O field is selected.
2. Press <Enter>. The selection list opens.
3. Select the desired entry from the selection list. Toggle between the next or previous entry by using the cursor keys <Left>, <Right>, <Up> and <Down>.
4. Confirm your input with <Enter> or cancel it with <Tab> or <Esc>.

## 6.2.5 Symbolic IO field

### Application

A symbolic I/O field can have the following Runtime functions:

- Output of text list entries
- Combined entry and output

Example of its use as combination I/O field:

To control a motor in Runtime, the operator selects the text "Motor OFF" or "Motor ON" from the text list. The motor is then started or stopped in accordance with the selection. The symbolic I/O field displays the respective status of the motor.



### Operation

Depending on the configuration, you can operate the symbolic I/O field in the following ways:

- Standard operation: Select an entry from the text list.
- Event: An event is triggered when you operate the symbolic I/O field, e.g. when you activate it. The processing of a function list can be configured to the event.

### Operation behavior

If the symbolic I/O field contains a blank text line in the selection list, no entries have been defined in the project. The contents of the symbolic I/O field change color to show that it is now activated.

### Operation with the mouse

1. Left mouse click on the symbolic I/O field. The selection list opens.
2. Click on the scroll bar with the mouse pointer. Move the scroll bar in the desired direction while holding down the left mouse button.
3. Select the desired entry with the left mouse button. The selection list is closed and the entry is displayed.

### Operation with the keyboard

1. Press the <Tab> key until the symbolic I/O field is selected.
2. Press <Enter>. The selection list opens.
3. Select the desired entry from the selection list. Toggle between the next or previous entry by using the cursor keys <Left>, <Right>, <Up> and <Down>.
4. Confirm your input with <Enter> or cancel it with <Tab> or <Esc>.

## 6.2.6 Alarm indicator

### Application

During Runtime, the alarm indicator is displayed if alarms of the specified alarm class are pending or require acknowledgement.



### Layout

The alarm indicator can have one of two states:

- Flashing: At least one unacknowledged alarm is pending.
- Static: The alarms are acknowledged but at least one of them is not yet deactivated.

### Operation

The icons from the symbol library can only be operated with a mouse or touch screen. Depending on the configuration, you can operate the alarm indicator in the following ways:

- Standard operation: Activate the alarm indicator.
- Event: An event is triggered when you operate the alarm indicator, e.g. when you click it. The processing of a function list can be configured to the event.

### Operation behavior

Depending on the configuration, when operating the alarm indicator an alarm window is opened.

### Operation with the mouse

1. Click on the alarm indicator with the mouse pointer. Depending on the configuration, the alarm window is opened.
2. Use the Close icon to close the Alarm window and be able to operate the screens. The alarm window can be opened again by clicking on the alarm indicator.

## 6.2.7 Alarm view

### Application

The alarm view shows selected alarms or events from the alarm buffer or alarm log.

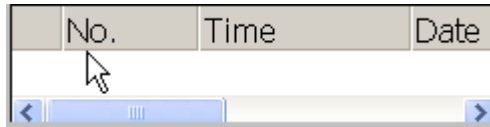

### Layout

Depending on the configuration, in the alarm view different columns with information regarding an alarm or an alarm event are displayed.

To differentiate between the different alarm classes, the first column in the alarm view contains a symbol:

Symbol	Alarm class
!	Error
(empty)	Operation
(depends on the configuration)	Custom alarm classes
\$	System

### Operation

Depending on the configuration you can:

- Change the column sequence
- Change the order in which the alarms are displayed
- Acknowledge alarms
- Edit alarm

### Operator control components

The buttons have the following functions:

Button	Function
	Displays an alarm operator note
	Editing alarms
	Acknowledge alarm

### Mouse and keyboard control

Within an alarm view there is a tabulator sequence that enables the operating elements and the last selected alarm to be selected via the keys of the HMI device.

### Operation with the mouse

1. Click on the alarm to be edited.
2. Click on the operating element you wish to use.

### Operation with the keyboard

1. Press the <Tab> key until the list of displayed alarms is selected in the alarm view.
2. Click on the alarm to be edited. You can use the keys <Home>, <End>, <Up> and <Down> for this
3. Press the <Tab> key until the operating element you wish to use is selected.
4. Press <Enter>.

### Alternative operation

Depending on the configuration, you can also operate the alarm view via the function keys.

### Example: Change the sequence of the columns

1. Choose the column header e.g. the "Date" column header.
2. While holding down the mouse button, drag the column header to the column header "Time".

### Example: Change the order of the columns

1. Click on the column header.
2. Click the same column header again to reverse the sort order.

### Example: Acknowledge alarm

1. Click on the alarm to be edited.
2. Click on the  button.

### Example: Edit alarm

1. Click on the alarm to be edited.
2. Click on the  button.

### Operation behavior

When you edit an unacknowledged alarm, it is acknowledged automatically.

## 6.2.8 Simple alarm view

### Application

The simple alarm view shows selected alarms or alarm events from the alarm buffer or alarm log.

#### Note

The "Single alarm view" object cannot be operated dynamically with a script.

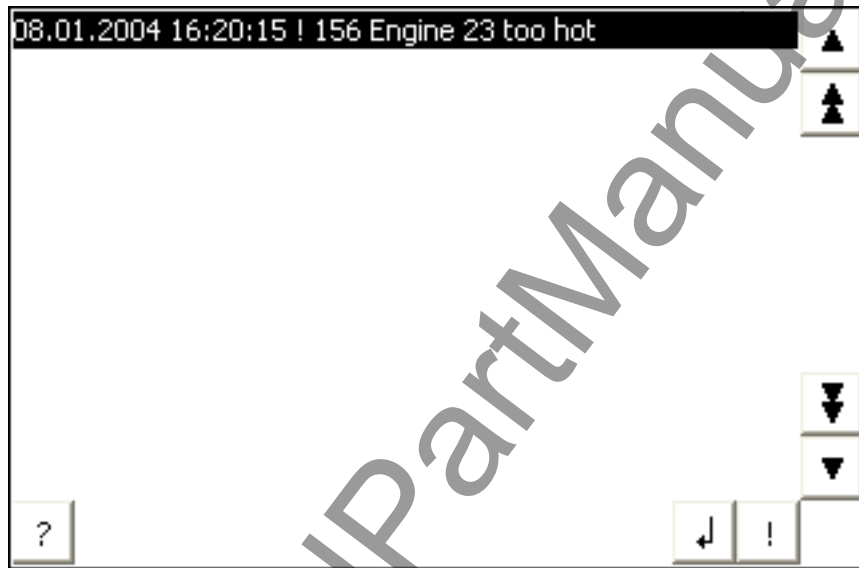

### Layout

Depending on the configuration, in the alarm view different columns with information regarding an alarm or an alarm event are displayed.

To differentiate between the different alarm classes, the first column in the alarm view contains a symbol:

Symbol	Alarm class
!	Error
(empty)	Operation
(depends on the configuration)	Custom alarm classes
\$	System







### Operation

Depending on the configuration you can:

- Acknowledge alarms
- Edit alarm

### Operator control components

The buttons have the following functions:

Button	Function
	Acknowledge alarm
	Edit alarm
	Displays an alarm operator note
	Scrolls one alarm up
	Scrolls one page up in the alarm view
	Scrolls one page down in the alarm view
	Scrolls one alarm down

### Mouse and keyboard control

Within the simple alarm view there is a tabulator sequence that enables the operating elements and the last selected alarm to be selected via the keys of the HMI device.

#### Operation with the mouse

1. Click on the alarm to be edited.
2. Click on the operating element you wish to use.

#### Operation with the keyboard

1. Press the <Tab> key until the list of displayed alarms is selected in the alarm view.
2. Click on the alarm to be edited. You can use the keys <Home>, <End>, <Up> and <Down> for this
3. Press the <Tab> key until the operating element you wish to use is selected.
4. Press <Enter>.

#### Alternative operation

Depending on the configuration, you can also operate the alarm view via the function keys.



### Example: Acknowledge alarm

1. Click on the alarm to be edited.
2. Click on the  button.

### Example: Edit alarm

1. Click on the alarm to be edited.
2. Click on the  button.

### Example: Calling the infotext

1. Click on the alarm to be edited.
2. Click on the  command button.
3. To close the window for displaying the operator note, press the  button or use the key combination <Alt+F4>.

## 6.2.9 Recipe view

### Application

With the recipe view, records can be displayed, edited and managed.

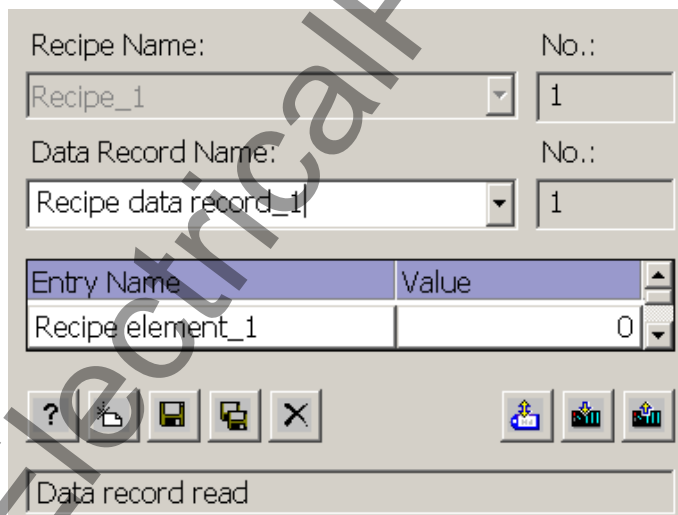

Entry Name	Value
Recipe element_1	0









**Operation**

Depending on the configuration you can:

- Create, change, copy or delete recipe records
- Read recipe records from the controller or transfer to the controller
- Export and import recipe data records

**Operator control components**

The following operator controls can be configured in the recipe view:

Operating element	Function
	Displays the configured operator notes of the given recipe view.
	Creates a new recipe record in the recipe that is displayed in the specified recipe view. The recipe record values are preset with the values that were specified as "Default value" when the recipe was configured.
	Saves the recipe data record which is currently displayed in the recipe view. The storage location is determined during configuration in the properties view for the recipe.
	Saves the recipe record currently being displayed in the recipe view under a new name. The storage location is determined during configuration in the properties view for the recipe.
	Deletes the recipe record that is displayed in the recipe view from the data medium of the HMI device.
	Synchronizes the values of the recipe record that is currently displayed in the recipe view with the associated tags. During synchronization, all values of the recipe record are written to the associated tags. Then the values are read from the tags and used to update the values in the recipe view.
	Transfers the recipe record, which is currently displayed in the recipe view, to the connected PLC.
	Transfers the recipe record, which is currently loaded in the PLC, to the HMI device and displays it in the recipe view.

**Operation behavior.**

When you change to a screen that contains a recipe view loaded with recipe data, the recipe data is automatically updated.

### Create, change, copy or delete recipe records

If the recipe data record already exists, a system alarm will be output to the screen.

If you change to another screen and have not yet saved changes to the recipe data in the recipe view, you will be prompted to save the recipe data. The recipe name and the name of the recipe record are displayed to show which recipe data have not been saved yet.

### Synchronizing a recipe data record

The system always updates the current value of the recipe view with the up-to-date recipe tag value.

When the value shown in the recipe view is more recent than the current recipe tag value, the system writes this value to the recipe tag.

### Operation with the mouse

1. Click on the desired recipe. The records for the recipe are displayed.
2. Click on the record you wish to edit.
3. Click on the operating element you wish to use.

### Operation with the keyboard

1. Press the <Tab> key until the recipe view is selected.
2. Press <Enter>. The selection list opens. Choose a recipe or a record from the list. Toggle between the next or previous entry by using the cursor keys <Left>, <Right>, <Up> and <Down>.
3. Press the <Tab> key until the operating element you wish to use is selected.  
Alternatively, you can operate the recipe view via key combinations.

The table below shows the shortcut keys used to control the recipe view.

Hotkeys	Function
<Ctrl+Space Bar>	Creates a new recipe record in the recipe that is displayed in the specified recipe view. The recipe record values are preset with the values that were specified as "Basic value" when the recipe was configured.
<Ctrl+Enter>	Saves the recipe data record which is currently displayed in the recipe view. The storage location is determined during configuration in the properties view for the recipe.
<Ctrl+*>	Saves the recipe record currently being displayed in the recipe view under a new name. The storage location is determined during configuration in the properties view for the recipe.
<Ctrl+Del>	Deletes the recipe record that is displayed in the recipe view from the data medium of the HMI device.
<Ctrl+=>	Synchronizes the values of the recipe record that is currently displayed in the recipe view with the associated tags.  During synchronization, all values of the recipe record are written to the associated tags. Then the values are read from the tags and used to update the values in the recipe view.

Hotkeys	Function
<Ctrl+Down>	Transfers the recipe record, which is currently displayed in the recipe view, to the connected PLC.
<Ctrl+Up>	Transfers the recipe record, which is currently loaded in the PLC, to the HMI device and displays it in the recipe view.

### Alternative operation

Depending on the configuration, you can also operate the button via the function keys.

### 6.2.10 Simple recipe view

#### Application

On an HMI device with a small display, the simple recipe view is used to display and edit recipes. In the simple recipe view, each area is shown separately on the HMI device. The simple recipe view always begins with the recipe selection.

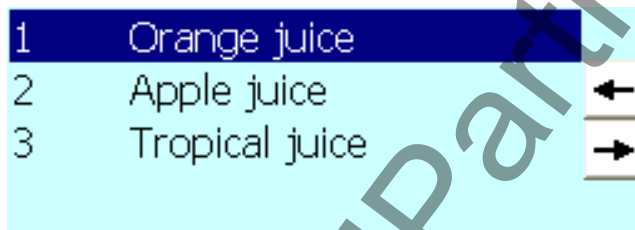

#### Layout

The simple recipe view consists of three areas:

- Recipe selection
- RecipeDataRecordSelection
- Recipe entries

In the simple recipe view, each area is shown separately on the HMI device. The simple recipe view always begins with the recipe selection.

---

#### Note

The "simple recipe view" object cannot be operated dynamically with a script.

---



#### Operation

Depending on the configuration you can:

- Create, change, copy or delete recipe records
- Synchronizing a recipe data record
- Ready recipe records from the controller or transfer to the controller
- Exporting and importing recipe data records

## Operator control components

The buttons have the following functions:

Button	Function
	Returns to the previous selection
	Calls the shortcut menu commands.

## Operation behavior

A command option selection can be called in for each display area by pressing the  button. The command selection lists those commands that are available in the current display area. Each command is assigned a number which you can use to select it directly from the list (without using the <Enter> key).

## Operation with the mouse

1. Click on the desired recipe. The records for the recipe are displayed.
2. Click on the record you wish to edit.
3. Click on the  command button. The menu for context-sensitive commands is opened.
4. Click on the menu entry you would like to use.

## Operation with the keyboard

1. Press the <Tab> key until the simple recipe view is selected.
2. Press <Return>. The records for the recipe are displayed.
3. Press the desired key combination.

The table below shows the shortcut keys used to control the recipe view.

Key	Function
<Right>	Calls the shortcut menu commands. Each command for processing recipes and recipe records is assigned a number that is shown in the command selection. You can select the command directly by pressing the corresponding number key on the HMI device.
<Up>/<Down>:	Selects the previous/next entry.
<Pg Up>/<Pg Down>	Scrolls one page up or down and selects the corresponding entry.
<Home>/<End>	Selects the first/last entry.
<Esc>	Returns to the previous selection
<Enter>	Displays the recipe data records or recipe elements according to the selection.

**Example: Copying a recipe data record**

1. Press the <Tab> key until the simple recipe view is selected.
2. Press <Enter>. The records for the recipe are displayed.
3. Press the cursor key <Right> or click on the  button. The menu for context-sensitive commands is opened.

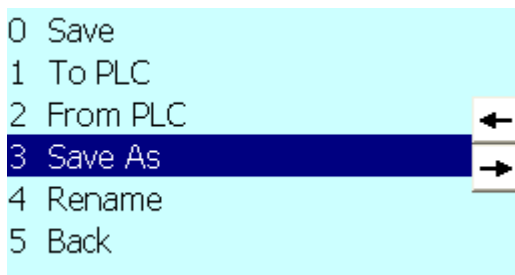

4. Press the <Down> cursor key until the entry "Save as" is selected. Confirm the entry by pressing the <Enter> key.
5. The dialog "Save as" is opened. Under name, enter the name of the record.
6. Click on the "OK" button.

**6.2.11 Bar**

**Application**

The bar represents a value from the controller in the form of a scaled bar graph. The operator at the HMI device can thus see immediately how far the current value is from the configured limit value or whether a reference value has been reached. The bar can display values such as fill levels or batch counts.

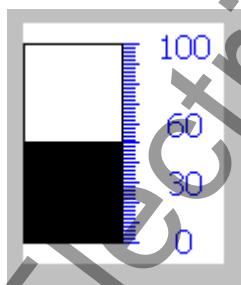

**Layout**

The layout of the bar depends on the configuration. In the bar, for example, lines can identify the configured limit values. Color changes can signal when a limit value has been exceeded or not been met.

**Operation**

The bar is for used only for visualization and can not be operated.

## 6.2.12 Trend view

### Application

The trend view is a dynamic display object. The Trend view can display actual process data and process data from a log continuously when it is supported by the HMI device.

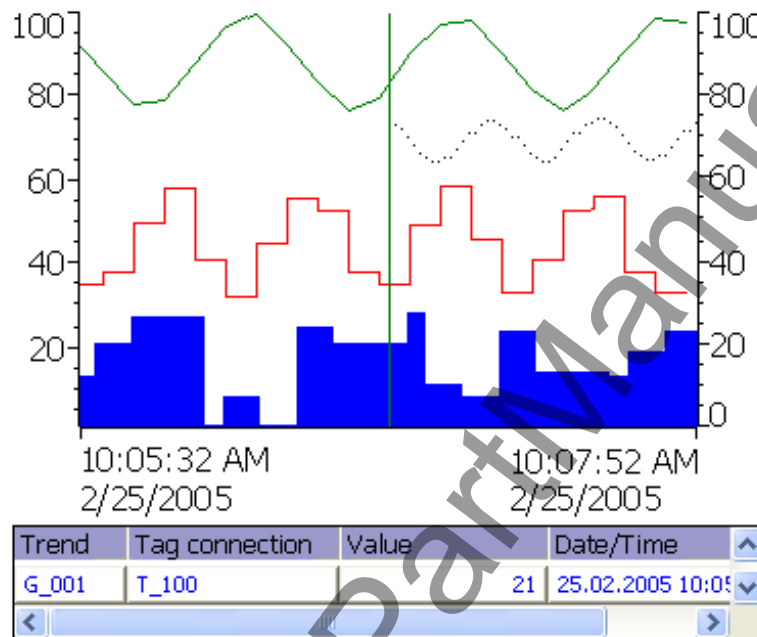

### Layout

The layout of the trend view is based on the configuration. A trend view can show multiple curves simultaneously to allow the user, for example, to compare different process sequences. If the displayed process value exceeds or falls below the configured limit values, the violation of the limit can be displayed by a change of color in the curve.

A ruler can also simplify the reading of the process values from the trend view. The ruler displays the Y-value that belongs to an X-value.









### Operation

Depending on the configuration you can:

- The displayed time section extends.
- The displayed time section reduces.
- Scroll back by one display width.
- Scroll forwards by one display width.
- Stop or continue the trend recording.

**Operator control components**

The buttons have the following functions:

Operating element	Function
	Scrolls back to the beginning of the trend recording. The start values of the trend recording are displayed there.
	Zooms the displayed time section
	Zooms out of the displayed time section
	Moves the ruler backward (to the left).
	Moves the ruler forward (to the right).
	Scrolls one display width backward (to the left).
	Scrolls one display width forward (to the right).
	Shows or hides the ruler. The ruler displays the X-value associated with a Y-value.
	Stops or continues trend recording

**Operation with the mouse**

1. Click on the desired button with the mouse button.

**Operation with the keyboard**

1. Press the <Tab> key until the trend view is selected.
2. Press the desired key combination.

The table below shows the shortcut keys used to control the recipe view.

Key	Key (Panel PC)	Function
<Ctrl+Enter>	<Ctrl+Enter>	Scrolls back to the beginning of the trend recording. The start values of the trend recording are displayed there.
<Ctrl+Plus>	<Ctrl+Plus>	Zooms the displayed time section
<Ctrl+Minus>	<Ctrl+Minus>	Zooms out of the displayed time section
--	<Ctrl+Alt+Left>	Moves the ruler backward (to the left).
--	<Ctrl+Alt+Right>	Moves the ruler forward (to the right).
<Shift+Left>	<Left>	Scrolls one display width backward (to the left).
<Shift+Right>	<Right>	Scrolls one display width forward (to the right).

**Alternative operation**

Depending on the configuration, you can also operate the button via the function keys.

### 6.2.13 Slider control

#### Application

The slider is used to transfer a numerical value to the PLC by moving the slide to the desired position. Each change in the position of a slider element causes the corresponding value in the associated tag to change immediately.

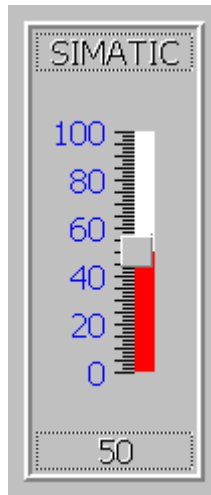

#### Layout

If the slider control is used as a display object, the value represented is determined by the position and configuration of the movable slider.

#### Operation

Depending on the configuration, you can operate the slider control in the following ways:

- Standard operation: Activate the slider.
- Event: An event is triggered when you operate the slider, e.g. when you activate it. The processing of a function list can be configured to the event.

#### Operation behavior

---

**Note**

The displayed value on the slider control may deviate from the actual value in the following circumstances:

- The value range (minimum and maximum value) configured for the slider control does not correspond to the configured limits for the slider control tag.
  - An invalid password has been entered for a password-protected slider control.
-

**Operation with the mouse**

- 1. Click the slider control.
- 2. Move the slider control in the desired direction while holding down the mouse button.

**Operation with the keyboard**

- 1. Press the <Tab> key until the trend view is selected.
- 2. You can operate the slider with the following keys:

Key	Key (Panel PC)	Function
<Up> or <Right>	<Shift+Up> or <Shift+Right>	Increase value
<Down> or <Left>	<Shift+Down> or <Shift+Left>	Reduce value
<Page up>	--	Increase value in 5% increments
<Page down>	--	Reduce value in 5% increments
<Home>	--	Set maximum value
<End>	--	Set minimum value

**6.2.14 Gauge**

**Application**

The gauge is a dynamic display object. The gauge displays numeric values in analog form by means of a pointer. The operator at the HMI device can thus see at a glance, for example, that the boiler pressure is in the normal range.

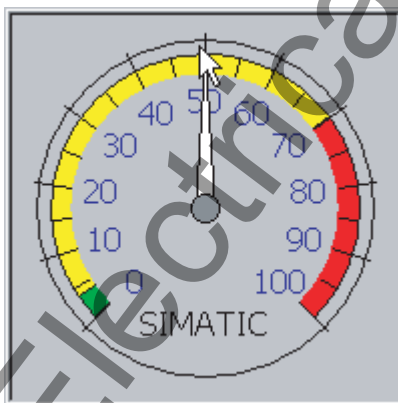

## Layout

The layout of the gauge depends on the configuration.

- Up to three differently colored areas can be set up on the scale to visualize different operating states, such as normal operation, warning range and danger range. With HMI devices with Windows CE the three areas in runtime are not displayed in different colors.
- A trailing pointer can display the maximum value reached so far on the scale. The trailing pointer is reset when the screen is reloaded.
- The label on the scale can show the measured variable, e.g. boiler pressure, and the physical unit, e.g. bar.

## Operation

The gauge is for display only and cannot be controlled by the operator.

### 6.2.15 Date/time field

#### Application

A "Date / time box" may have the following runtime functions:

- Output of the date and time
- Combined input and output; here the operator can edit the output values so as to reset the date and time.



#### Layout

The layout in the date/time field depends on the language set in the HMI device.

The date can be displayed in detail (e.g. Tuesday, 31 December 2003) or in short form (31.12.2003).

#### Operation

Depending on the configuration, you can operate the date/time field in the following ways:

- Standard operation: Change date and time.

#### Operation behavior

When the operator ignores the syntax when entering values, or enters illegal values, the system rejects these. Instead, the original values (plus the time that has elapsed in the meantime) will appear in the date/time field and a system alarm will be displayed on the HMI device.

### Operation with the mouse

1. Click in the date/time field.
2. Type in the relevant value.
3. Confirm your input on the HMI with <Return> or cancel it with <Esc>.

### Operation with the keyboard

1. Press the <Tab> key until the date/time field is selected.
2. Set the value.
3. Confirm your input with <Enter> or cancel it with <Esc>.

### Alternative operation with the keyboard

1. Press the <Tab> key until the date/time field is selected.
2. Press <Enter>. The object changes to the specific editing mode. Now, only one character will be marked in the field.
3. Use the <Up>/<Down> cursor keys to scroll through a character table.
4. Use the <Right>/<Left> cursor keys to move the cursor to the next or previous input position.
5. Confirm your input with <Enter> or cancel it with <Esc>.

## 6.2.16 Clock

### Application

The clock displays the system time of the HMI device.

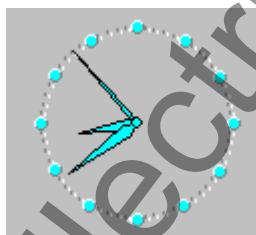

### Layout

The time is displayed in analog or digital form, depending on the configuration. The current date is also displayed in the digital view. The display format depends on the language set on the HMI device.

### Operation

The clock is for display only and cannot be operated. You can use the Date/Time field, for example, to set the date and time.

## 6.2.17 User view

### Application

The user view is used by the administrator to manage user accounts, group assignments and user passwords.

Users can change their passwords and logoff times.

User	Password	Group	Logoff time
Admin	*****	Group (9)	5
PLC User	*****	Group (1)	5
User 1	*****	Group (1)	5

### Layout

The user view contains four columns for the user, password, group and log-off time. The passwords are encrypted by means of asterisks.

- All users on the HMI device system are displayed in the User view to the administrator or to a user with administrator authorizations.
- When user administration authorization is lacking, only the personal user entry is displayed.

### Operation

Depending on the configuration you can:

- Manage users, e.g. create, delete.
- Change existing user data
- Export or import user data

---

#### Note

On an HMI device the number is restricted to 100 users and one PLC user. This restriction does not apply to PCs. On a PC, the maximum number of users is restricted by the physical memory.

---

## Operation behavior

### Change existing user data

The following options are available for the range of changes that can be made:

- The administrator or a user with user administration authorization can change the data for all users on the HMI device system in the user view.
  - User name
  - Group assignment
  - Password
  - Logoff times
- A user without user administration authorization can only change their own user data:
  - Password
  - Logoff time

### Export or import user data

A user view contains all users, passwords, group assignments and logoff times set up on the HMI device. To eliminate the necessity of reentering all data again on another HMI device, you can export the user view, and then import it to another device. However, this is only possible if this function has been configured.

---

#### Note

Do not export the password list immediately after changing it. Exit the "User view" object after making changes and wait until the changes have been written to the internal Flash memory before performing the export.

---

#### Notice

The currently valid passwords are overwritten during an import. The imported user data and passwords are valid immediately.

---

### Operation with the mouse

1. Click in the user view.
2. Click on the user to be edited.
3. Edit the user data.

### Operation with the keyboard

1. Press the <Tab> key until the user view is selected.
2. Click on the user to be edited. You can use the keys <Home>, <End>, <Up> and <Down> for this
3. Edit the user data

#### Example: Create user

1. Click on an empty line in the "User" column of the user view.
2. Then enter the user name. Press <Enter>.
3. Use <Right> to select the next field.
4. Assign a password and a logoff time in the same way and then select the group.

#### Example: Changing group assignments

1. Click in the "Group" field.
2. Select a group from the selection list. Alternatively, you can use the cursor keys <Home>, <End>, <Up> and <Down> for this
3. Confirm the entry with <Enter>.

### 6.2.18 Simple user view

#### Application

On HMI devices with a small display, the simple user view is used to display users on the HMI device.



#### Note

The "simple user view" object cannot be operated dynamically with a script.

#### Layout

The layout depends on the user rights.

- All users on the HMI device system are displayed in the User view to the administrator or to a user with administrator authorizations.
- When user administration authorization is lacking, only the personal user entry is displayed.

### Operation

Depending on the configuration you can:

- Manage users, e.g. create, delete
- Change existing user data
- Export or import user data

---

#### Note

On an HMI device the number is restricted to 100 users and one PLC user. This restriction does not apply to PCs. On a PC, the maximum number of users is restricted by the physical memory.

---

### Operation with the mouse

1. Click on the user name to be edited.
2. Change the user data. Custom user data (name, password, group, logoff time) is entered sequentially in several dialogs.
3. use the "OK" button to confirm the entries.

### Operation with the keyboard

1. Press the <Tab> key until the simple user view is selected.
2. Click on the user to be edited.
3. Confirm the selection by pressing the <Enter> key. You can change the user data in the following dialogs.
4. use the "OK" button to confirm the entries.

The following table shows the available key operations for entering custom user data in the dialogs:

Key	Function
<Up>/<Down>	Selects the previous/next user
<Tab>	Selects the next element in the dialog
<Enter>	Opens the next dialog
<DEL>	Deletes the selected user.

### Example: Changing user data

1. Click on the user name to be edited. The following dialog opens:

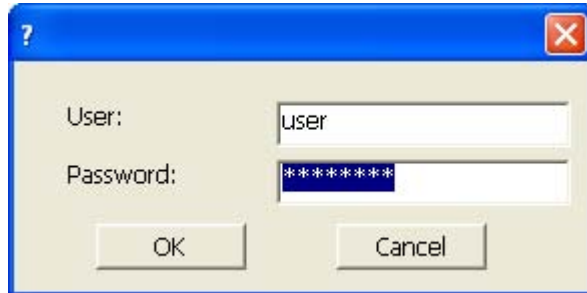

2. If necessary, change the user name and password. Click on the "OK" button. The following dialog opens:



3. If necessary, change the user group and the logoff time. Click on the "OK" button.

## 6.2.19 Symbol library

### Application

The symbol library is a comprehensive library with images from the areas of technology and production.

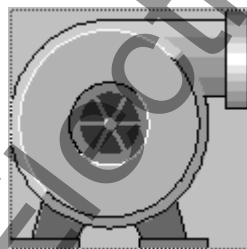

### Operation

Depending on the configuration, you have the following methods of operation:

- Event: An event is triggered when you operate the symbol, e.g. when you activate it. The processing of a function list can be configured to the event.

**Operation behavior**

The active mouse function is signaled in Runtime by a changing cursor icon according to your configuration.

There is no operator feedback, for example with color changes.

**Operation with the mouse**

1. Click on the symbol with the mouse pointer.
2. The functions are event-triggered.

**6.2.20 Status force**

**Application**

You read or write access values of the connected PLC directly in the status / control view. The status / control view allows you to carry out operations such as monitoring or modifying the addresses of the PLC program, without the need of an online connection via PC or PG.

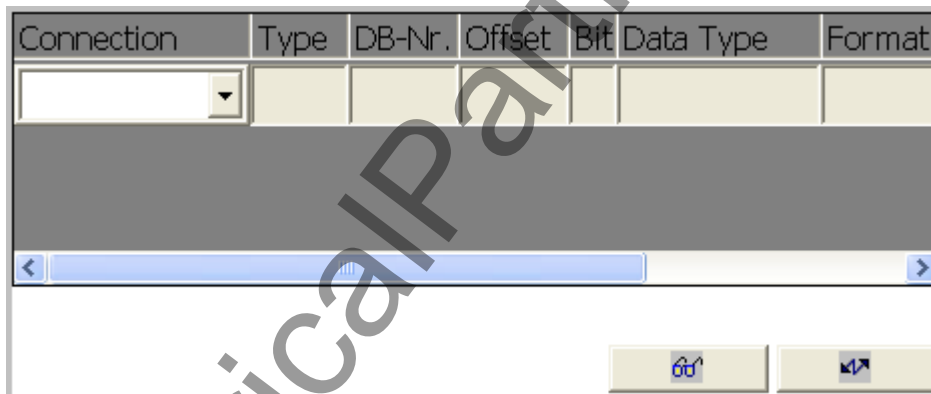

**Note**

The status/control view can only be used in combination with SIMATIC S5 or SIMATIC S7 PLCs.

## Layout

The screen shows the general layout of the status / control screen object. Every row represents an address.

The table shows the meaning of the individual columns.

Column	Function
Connection	The PLC of which the address ranges are to be displayed
Type, DB number, offset, bit	The address range of the operand
Data type, format	The data type of the operand
Status value	The value that was read from the given address of the operand
Control value	The value to be written to the given address of the operand



## Operation

Depending on the configuration you can:

- Change the column sequence  
To reverse the "Format" and "Control value" columns, drag the "Format" header to the "Control value" header while holding down the mouse button.
- Write the control value in the PLC.

## Operator control components

The buttons have the following functions:

Button	Function
	Updates the display in the status value column. The button engages when it is pressed. You cannot operate any input fields until the button is actuated again and the refresh is stopped.
	Accepts the new value in the control value column. The control value is then written to the PLC.

## Operation with the mouse

1. Click on the respective field.
2. Enter the value using the keyboard, or select a value from the selection list.
3. Click the desired buttons to write or read the values.

### Operation with the keyboard

1. Press the <Tab> key until the status/control view is selected.
2. Press the desired key combination.

The following table shows the key combinations for operating the status/control view.

Key	Key (Panel PC)	Function
<Ctrl+Enter>	<Ctrl+Enter>	Operating the "Write" button
<Ctrl+Space Bar>	<Ctrl+Space>	Operating the "Read" button
<Ctrl+Left>	<Ctrl+Shift+Left>	Selects first field in current row
<Ctrl+Right>	<Ctrl+Shift+Right>	Selects last field in current row
<Ctrl+Up>	<Ctrl+Shift+Up>	Selects first field in current column
<Ctrl+Down>	<Ctrl+Shift+Down>	Selects last field in current column
<Ctrl+Del>	<Ctrl+INS/DEL>	Deletes current row
<Enter>	<Enter>	Opens selection list

### 6.2.21 HTML browser

#### Application

You can use the the HTML browser to browse web sites. This allows you to access additional information.



#### Operation

Depending on the configuration you can:

- Update the content of the web page.
- Enter an Internet address.

## Operator control components

The HTML browser may feature the following operator controls, depending on the configuration:

Button	Function
Previous	Returns to the previously displayed page
Forward	Jumps to the page that has already been accessed once from the current page
Update	Updates the displayed contents (reloads the web page)
Cancel	Cancels loading of the page

## Operation behavior

The HTML browser responds in the same way as the Internet Explorer. You click a relevant link to open a further page.

The project engineer can also provide for the input or activation of an Internet address. As soon as you input or activate an address, the HTML browser opens that page.

## Remarks

The functional scope of the HTML browser is limited in comparison to the Internet Explorer:

- VBScript, Java, and JavaScript are not supported.
- ActiveX-Controls are not supported.
- Links to embedded files, for example \*.pdf or \*.xls, are not supported.
- Queries and dialogs that are conducted during the access of corresponding pages are not supported. This means that, for example, access to pages with invalid certificates is possible. In order to access pages which require authentication the user name and the password can be specified in the URL: <http://User\_Name:Password@Server\_Name> (for example, http://otto:asdf@192.168.56.199).

## Operation with the mouse

1. Click in the address line.
2. Enter the Internet address.
3. In order to reach a linked page, click on the link.

## Operation with the keyboard

1. Press the <Tab> key until the address line is activated.
2. Enter the Internet address. The HTML browser opens the page in question.

### 6.2.22 Sm@rtClient view

#### Application

The Sm@rtClient view may be used to start remote monitoring and control of another HMI device. With an appropriate configuration, the Sm@rtClient view can be used to monitor and control a system process from multiple HMI devices with the same authorizations.



#### Layout

The Sm@rtClient view displays the current Runtime screen of the remote device on your HMI device.

You can now monitor and control this screens according to your configuration. Scroll bars are displayed if the screen of the remote HMI device is larger than that of the current HMI device.

#### Operation

Depending on the configuration, you can operate the Sm@rtClient view in the following ways:

- Keys

In operation mode, all keys have the same function as those on the remote HMI device. You can therefore use the <Tab> key to move from one object to another on the remote screen, in the order of the tab configuration.

- Function keys

When you press a function key that has been configured with a function, this function will be executed in your project.

If you press a function key that has not been configured with a function in your project, it will actuate the respective function key on the remote HMI device.

---

- **Note**

In the event of emergency, you can override the operation block on the remotely controlled or currently inactive HMI device by clicking on the user interface five times in succession or pressing the <Shift> key five times in succession. Then you may have to enter a specific (configured) password.

---

## Monitoring mode

On a Sm@rtClient view which is configured for monitoring mode, you can only monitor the remote HMI device. You cannot control its operation.

In this case, the keys retain their standard functions. Press <Tab> to open the next object in the current screen of your project.

## Operation with the mouse

1. Click on the desired control object with the mouse pointer.
2. Click on the scroll bar with the mouse pointer. Move the scroll bar in the desired direction while holding down the left mouse button.
3. Press the left mouse button for a few seconds on an empty area. The shortcut menu is opened.
4. Select the desired menu command.

## Operation with the keyboard

1. Press the <Tab> key until the Sm@rtClient view is selected.
2. Move the scroll bar in the desired direction using <Ctrl+Up> and <Ctrl+Down>.
3. Open a menu line with the key combination <Shift+Ctrl>.
4. Select the desired menu command with <Alt+Shortcut key>.

## Operation behavior

### Call-up

The call for starting remote monitoring or control can be configured in different ways. You can open the view of the runtime of the remote operator device with the following steps, depending on the project:

- Automatically when the device is started (and selection of the screen with the Sm@rtClient view, if this is not the start screen)
- By activating the Sm@rtClient view with the <Tab> key or (on a touch screen device) through a touch
- By entering the IP address of the remote HMI device and, if required, entering a password in the appropriate field in the Sm@rtClient view

---

### Note

If you enter an incorrect password five times in succession, all attempts to establish a connection are rejected for the next ten seconds.

---

### Stop

The screen showing the display of the remote HMI device can be configured to be closed in different ways. Depending on the configuration, you can terminate the remote monitoring or remote operation and open the next object of your own project by taking one of the following steps:

- Press the appropriate key.
- Click "Exit".
- Exit the screen.
- Press <Shift+Ctrl> or (with touch devices) press a clear spot for an extended period. The menu opens with the corresponding menu item.

# HMI system alarms

## Introduction

System alarms on the HMI device provide information about internal states of the HMI device and PLC.

The overview below shows the causes of system alarms and how to eliminate the cause of error.

Some of the system alarms described in this section are relevant to individual HMI devices based on their range of features.

---

### Note

System alarms are only indicated if an alarm window was configured. System alarms are output in the language currently set on your HMI device.

---

## System alarm parameters

System alarms may contain encrypted parameters which are relevant to troubleshooting because they provide a reference to the source code of the Runtime software. These parameters are output after the text "Error code:"

## Meaning of the system alarms

Number	Effect/cause	Remedy
10000	The print job could not be started or was canceled due to an unknown error. Faulty printer setup. Or: No permission is available for accessing the network printer. Power supply failure during data transfer.	Check the printer settings, cable connections and the power supply. Set up the printer once again. Obtain a network printer authorization. If the error persists, contact the Hotline!
10001	No printer is installed or a default printer has not been set up.	Install a printer and/or select it as the default printer.
10002	Overflow of the graphics buffer for printing. Up to two images are buffered.	Allow sufficient intervals between successive print jobs.
10003	Images can now be buffered again.	—
10004	Overflow of the buffer for printing lines in text mode (e.g.alarms). Up to 1000 lines are buffered.	Allow sufficient intervals between successive print jobs.
10005	Text lines can now be buffered again.	—
10006	The Windows printing system reports an error. Refer to the output text and the error ID to determine the possible causes. Nothing is printed or the print is faulty.	Repeat the action if necessary.

Number	Effect/cause	Remedy
20010	An error has occurred in the specified script line. Execution of the script was therefore aborted. Note the system alarm that may have occurred prior to this.	Select the specified script line in the configuration. Ensure that the tags used are of the allowed types. Check system functions for the correct number and types of parameters.
20011	An error has occurred in a script that was called by the specified script. Execution of the script was therefore aborted in the called script. Take the system alarm that may have occurred prior to this into account.	In the configuration, select the script that has been called directly or indirectly by the specified script. Ensure that the tags used are of the allowed types. Check the system functions for the correct number and type of parameters.
20012	The configuration data is inconsistent. The script could therefore not be generated.	Recompile the configuration.
20013	The scripting component of WinCC flexible Runtime is not correctly installed. Therefore, no scripts can be executed.	Reinstall WinCC flexible Runtime.
20014	The system function returns a value that is not written in any return tag.	Select the specified script in the configuration. Check if the script name has been assigned a value.
20015	Too many successive scripts have been triggered in short intervals. When more than 20 scripts are queued for processing, any subsequent scripts are rejected. In this case, the script indicated in the alarm is not executed.	Find what is triggering the scripts. Extend the times, e.g. the polling time of the tags which trigger the scripts.
30010	The tag could not accept the function result, e.g. when it has exceeded the value range.	Check the tag type of the system function parameter.
30011	A system function could not be executed because the function was assigned an invalid value or type in the parameter.	Check the parameter value and tag type of the invalid parameter. If a tag is used as a parameter, check its value.
40010	The system function could not be executed since the parameters could not be converted to a common tag type.	Check the parameter types in the configuration.
40011	The system function could not be executed since the parameters could not be converted to a common tag type.	Check the parameter types in the configuration.
50000	The HMI device is receiving data faster than it is capable of processing. Therefore, no further data is accepted until all current data have been processed. Data exchange then resumes.	—
50001	Data exchange has been resumed.	—
60000	This alarm is generated by the "DisplaySystemAlarms" function. The text to be displayed is transferred to the function as a parameter.	—
60010	The file could not be copied in the direction defined because one of the two files is currently open or the source/target path is not available. It is possible that the Windows user has no access rights to one of the two files.	Restart the system function or check the paths of the source/target files. Using Windows NT/2000/XP: The user executing WinCC flexible Runtime must be granted access rights for the files.
60011	An attempt was made to copy a file to itself. It is possible that the Windows user has no access rights to one of the two files.	Check the path of the source/target file. Using Windows NT/2000/XP with NTFS: The user executing WinCC flexible Runtime must be granted access rights for the files.

Number	Effect/cause	Remedy
70010	The application could not be started because it could not be found in the path specified or there is insufficient memory space.	Check if the application exists in the specified path or close other applications.
70011	The system time could not be modified. The error alarm only appears in connection with area pointer "Date/time PC". Possible causes: <ul style="list-style-type: none"> <li>An invalid time was transferred in the job mailbox.</li> <li>The Windows user has no right to modify the system time.</li> </ul> If the first parameter in the system alarm is displayed with the value 13, the second parameter indicates the byte containing the incorrect value.	Check the time which is to be set. Using Windows NT/2000/XP: The user executing WinCC flexible Runtime must be granted the right to change the system time of the operating system.
70012	An error occurred when executing the function "StopRuntime" with the option "Runtime and operating system". Windows and WinCC flexible Runtime are not closed. One possible cause is that other programs cannot be closed.	Close all programs currently running. Then close Windows.
70013	The system time could not be modified because an invalid value was entered. Incorrect separators may have been used.	Check the time which is to be set.
70014	The system time could not be modified. Possible causes: <ul style="list-style-type: none"> <li>An invalid time was transferred.</li> <li>The Windows user has no right to modify the system time.</li> <li>Windows rejects the setting request.</li> </ul>	Check the time which is to be set. Using Windows NT/2000/XP: The user executing WinCC flexible Runtime must be granted the right to change the system time of the operating system.
70015	The system time could not be read because Windows rejects the reading function.	—
70016	An attempt was made to select a screen by means of a system function or job. This is not possible because the screen number specified does not exist. Or: A screen could not be generated due to insufficient system memory.	Check the screen number in the function or job with the screen numbers configured. Assign the number to a screen if necessary.
70017	Date/Time is not read from the area pointer because the address set in the controller is either not available or has not been set up.	Change the address or set up the address in the controller.
70018	Acknowledgment that the password list has been successfully imported.	—
70019	Acknowledgment that the password list has been successfully exported.	—
70020	Acknowledgment for activation of alarm reporting.	—
70021	Acknowledgment for deactivation of alarm reporting.	—
70022	Acknowledgment to starting the Import Password List action.	—
70023	Acknowledgment to starting the Export Password List action.	—

Number	Effect/cause	Remedy
70024	The value range of the tag has been exceeded in the system function. The calculation of the system function is not performed.	Check the desired calculation and correct it if necessary.
70025	The value range of the tag has been exceeded in the system function. The calculation of the system function is not performed.	Check the desired calculation and correct it if necessary.
70026	No other screens are stored in the internal screen memory. No other screens can be selected.	—
70027	The backup of the RAM file system has been started.	—
70028	The files from the RAM have been copied in the Flash memory. The files from the RAM have been copied in the Flash memory. Following a restart, these saved files are copied back to the RAM file system.	—
70029	Backup of the RAM file system has failed. No backup copy of the RAM file system has been made.	Check the settings in the "Control Panel > OP" dialog and save the RAM file system using the "Save Files" button in the "Persistent Storage" tab.
70030	The parameters configured for the system function are faulty. The connection to the new controller was not established.	Compare the parameters configured for the system function with the parameters configured for the controllers and correct them as necessary.
70031	The controller configured in the system function is not an S7 controller. The connection to the new controller was not established.	Compare the S7 controller name parameter configured for the system function with the parameters configured for the controller and correct them as necessary.
70032	The object configured with this number in the tab order is not available in the selected screen. The screen changes but the focus is set to the first object.	Check the number of the tab order and correct it if necessary.
70033	An e-mail cannot be sent because a TCP/IP connection to the SMTP server no longer exists. This system alarm is generated only at the first attempt. All subsequent unsuccessful attempts to send an e-mail will no longer generate a system alarm. The event is regenerated when an e-mail has been successfully sent in the meantime. The central e-mail component in WinCC flexible Runtime attempts, in regular intervals (1 minute), to establish the connection to the SMTP server and to send the remaining e-mails.	Check the network connection to the SMTP server and re-establish it if necessary.
70034	Following a disruption, the TCP/IP connection to the SMTP server could be re-established. The queued e-mails are then sent.	—
70036	No SMTP server for sending e-mails is configured. An attempt to connect to an SMTP server has failed and it is not possible to send e-mails. WinCC flexible Runtime generates the system alarm after the first attempt to send an e-mail.	Configure an SMTP server: In WinCC flexible Engineering System using "Device settings > Device settings" In the Windows CE operating system using "Control Panel > Internet Settings > E-mail > SMTP Server"

Number	Effect/cause	Remedy
70037	An e-mail cannot be sent for unknown reasons. The contents of the e-mail are lost.	Check the e-mail parameters (recipient etc.).
70038	The SMTP server has rejected sending or forwarding an e-mail because the domain of the recipient is unknown to the server or because the SMTP server requires authentication. The contents of the e-mail are lost.	Check the domain of the recipient address or deactivate the authentication on the SMTP server if possible. SMTP authentication is currently not used in WinCC flexible Runtime.
70039	The syntax of the e-mail address is incorrect or contains illegal characters. The contents of the e-mail are discarded.	Check the e-mail address of the recipient.
70040	The syntax of the e-mail address is incorrect or contains illegal characters.	—
70041	The import of the user management was aborted due to an error. Nothing was imported.	Check your user management or transfer it again to the panel.
80001	The log specified is filled to the size defined (in percent) and must be stored elsewhere.	Store the file or table by executing a 'move' or 'copy' function.
80002	A line is missing in the specified log.	—
80003	The copying process for logging was not successful. In this case, it is advisable to check any subsequent system alarms, too.	—
80006	Since logging is not possible, this causes a permanent loss of the functionality.	In the case of databases, check if the corresponding data source exists and start up the system again.
80009	A copying action has been completed successfully.	—
80010	Since the storage location was incorrectly entered in WinCC flexible, this causes a permanent loss of the functionality.	Configure the storage location for the respective log again and restart the system when the full functionality is required.
80012	Log entries are stored in a buffer. If the values are read to the buffer faster than they can be physically written (using a hard disk, for example), overloading may occur and recording is then stopped.	Archive fewer values. Or: Increase the logging cycle.
80013	The overload status no longer applies. Archiving resumes the recording of all values.	—
80014	The same action was triggered twice in quick succession. Since the process is already in operation, the action is only carried out once.	—
80015	This system alarm is used to report DOS or database errors to the user.	—
80016	The logs are separated by the system function "CloseAllLogs" and the incoming entries exceed the defined buffer size. All entries in the buffer are deleted.	Reconnect the logs.
80017	The number of incoming events cause a buffer overflow. This can be caused, for example, by several copying actions being activated at the same time. All copy jobs are deleted.	Stop the copy action.

Number	Effect/cause	Remedy
80019	The connection between WinCC flexible and all logs were closed, for example, after executing the system function "CloseAllLogs". Entries are written to the buffer and are then written to the logs when a connection is re-established. There is no connection to the storage location and the storage medium may be replaced, for example.	—
80020	The maximum number of simultaneously copy operations has been exceeded. Copying is not executed.	Wait until the current copying actions have been completed, then restart the last copy action.
80021	An attempt was made to delete a log which is still busy with a copy action. Deletion has not been executed.	Wait until the current copying actions have been completed, then restart the last action
80022	An attempt was made to start a sequence log, which is not a sequence log, from a log using the system function "StartSequenceLog". No sequence log file is created.	In the project, check <ul style="list-style-type: none"> <li>• if the "StartSequenceLog" system function was properly configured</li> <li>• if the tag parameters are properly provided with data on the HMI device</li> </ul>
80023	An attempt was made to copy a log to itself. The log is not copied.	In the project, check <ul style="list-style-type: none"> <li>• if the "CopyLog" system function was properly configured</li> <li>• if the tag parameters are properly provided with data on the HMI device</li> </ul>
80024	The "CopyLog" system function does not allow copying when the target log already contains data ("Mode" parameter). The log is not copied.	Edit the "CopyLog" system function in the project if necessary. Before you initiate the system function, delete the destination log file.
80025	You have canceled the copy operation. Data written up to this point are retained. The destination log file (if configured) is not deleted. The cancellation is reported by an error entry \$RT_ERR\$ at the end of the destination log.	—
80026	This alarm is output after all logs are initialized. Values are written to the logs from then on. Prior to this, no entries are written to the logs, irrespective whether WinCC flexible Runtime is active or not.	—
80027	The internal Flash memory has been specified as the storage location for a log. This is not permissible. No values are written to this log and the log file is not created.	Configure "Storage Card" or a network path as the storage location.
80028	The alarm returns a status report indicating that the logs are currently being initialized. No values are logged until the alarm 80026 is output.	—
80029	The number of logs specified in the alarm could not be initialized. The logs are initialized. The faulty log files are not available for logging jobs.	Evaluate the additional system alarms , related to this alarm which is also generated. Check the configuration, the ODBC (Open Database Connectivity) and the specified drive.
80030	The structure of the existing log file does not match the expected structure. Logging is stopped for this log.	Delete the existing log data manually, in advance.
80031	The log in CSV format is corrupted. The log cannot be used.	Delete the faulty file.

Number	Effect/cause	Remedy
80032	Logs can be assigned events. These are triggered as soon as the log is full. If WinCC flexible Runtime is started and the log is already full, the event is not triggered. The log specified no longer logs data because it is full.	Close WinCC flexible Runtime, delete the log, then restart WinCC flexible Runtime. Or: Configure a button which contains the same actions as the event and press it.
80033	"System Defined" is set in the data log file as the data source name. This causes an error. No data is written to the database logs, whereas the logging to the CSV logs works.	Install MSDE again.
80034	An error has occurred in the initialization of the logs. An attempt has been made to create the tables as a backup. This action was successful. A backup has been made of the tables of the corrupted log file and the cleared log was restarted.	No action is necessary. However, it is recommended to save the backup files or delete them in order to make the space available again.
80035	An error has occurred in the initialization of the logs. An attempt has been made to create backups of the tables and this has failed. No logging or backup has been performed.	It is recommended to save the backups or to delete them in order to release memory.
80044	The export of a log was interrupted because Runtime was closed or due to a power failure. It was detected that the export needed to be resume when Runtime restarted.	The export resumes automatically.
80045	The export of a log was interrupted due to an error in the connection to the server or at the server itself.	The export is repeated automatically. Check: <ul style="list-style-type: none"> <li>• the connection to the server</li> <li>• if the server is running</li> <li>• if there is enough free space on the server.</li> </ul>
80046	The destination file could not be written while exporting the log.	Check if there is enough space on the server and if you have permission to create the log file.
80047	The log could not be read while exporting it.	Check if the storage medium is correctly inserted.
80048	—	—
80049	The log could not be renamed while preparing to export it. The job can not be completed."	Check if the storage medium is correctly inserted and if there is sufficient space on the medium.
80050	The log which shall be exported is not closed. The job can not be completed.	Make sure the "CloseAll Logs" system function is called before using the "ExportLog" system function. Change the configuration as required.
90024	No operator actions can be logged due to lack of space on the storage medium for log. The operator action will therefore not be executed.	Make more space available by inserting an empty storage medium or swapping out the log files on the server using "ExportLog".
90025	Because of error state of the archive no user actions can be logged. Therefore the user action will not be executed.	Check if the storage medium is correctly inserted.
90026	No operator actions can be logged because the log is closed. The operator action will therefore not be executed.	Before further operator actions are carried out, the log must be opened again using the system function "OpenAllLogs". Change the configuration as required.
90029	Runtime was closed during ongoing operation (perhaps due to a power failure) or an a storage medium in use is incompatible with Audit Trail. An Audit Trail is not suitable if it belongs to another project or has already be archived.	Ensure that you are using the correct storage medium.

Number	Effect/cause	Remedy
90030	Runtime was closed during ongoing operation (perhaps due to a power failure).	—
90031	Runtime was closed during ongoing operation (perhaps due to a power failure).	—
90032	Running out of space on the storage medium for log.	Make more space available by inserting an empty storage medium or swapping out the log files on the server using "ExportLog".
90033	No more space on the storage medium for log. As of now, no more operator actions requiring logging will be executed.	Make more space available by inserting an empty storage medium or swapping out the log files on the server using "ExportLog".
90040	Audit Trail is switched off because of a forced user action.	Activate the "Audit Trail" again using the system function "StartLog".
90041	A user action which has to be logged has been executed without a logged on user.	A user action requiring logging should only be possible with permission. Change the configuration by setting a required permission for the input object.
90044	A user action which has to be confirmed was blocked, because there is another user action pending.	Repeat the user action if necessary.
110000	The operating mode was changed. "Offline" mode is now set.	—
110001	The operating mode was changed. "Online" mode is now set.	—
110002	The operating mode was not changed.	Check the connection to the controllers. Check if the address area for the area pointer 88 "Coordination" in the controller is available.
110003	The operating mode of the specified controller was changed by the system function "SetConnectionMode". The operating mode is now "offline".	—
110004	The operating mode of the specified controller has been changed by the system function "SetConnectionMode". The operating mode is now "online".	—
110005	An attempt was made to use the system function SetConnectionMode to switch the specified controller to "online" mode, although the entire system is in "offline" mode. This changeover is not allowed. The controller remains in "offline" mode.	Switch the complete system to "online" mode, then execute the system function again.
110006	The content of the "project version" area pointer does not match the user version configured in WinCC flexible. WinCC flexible Runtime is therefore closed.	Check: <ul style="list-style-type: none"> <li>the project version entered on the controller</li> <li>the project version entered in WinCC flexible</li> </ul>
120000	The trend is not displayed because you configured an incorrect axis to the trend or an incorrect trend.	Change the configuration.
120001	The trend is not displayed because you configured an incorrect axis to the trend or an incorrect trend.	Change the configuration.
120002	The trend is not displayed because the tag assigned attempts to access an invalid controller address.	Check if the data area for the tag exists in the controller, the configured address is correct and the value range for the tag is correct.
130000	The action was not executed.	Close all other programs. Delete files no longer required from the hard disk.
130001	The action was not executed.	Delete files no longer required from the hard disk.

Number	Effect/cause	Remedy
130002	The action was not executed.	Close all other programs. Delete files no longer required from the hard disk.
130003	No data medium found. The operation is canceled.	Check, for example, if <ul style="list-style-type: none"> <li>• the correct data medium is being accessed</li> <li>• the data medium is inserted</li> </ul>
130004	The data medium is write-protected. The operation is canceled.	Check if access has been made to the correct data carrier. Remove the write protection.
130005	The file is read only. The operation is canceled.	Check if access has been made to the correct file. Edit the file attributes if necessary.
130006	Access to file failed. The operation is canceled.	Check, for example, if <ul style="list-style-type: none"> <li>• the correct file is being accessed</li> <li>• the file exists</li> <li>• another action is preventing simultaneous access to the file</li> </ul>
130007	The network connection is interrupted. Data records cannot be saved or read over the network connection.	Check the network connection and eliminate the cause of error.
130008	The storage card is not available. Data records cannot be saved to / read from the storage card.	Insert the storage card.
130009	The specified folder does not exist on the storage card. Any files saved to this directory are not backed up when you switch off the HMI device.	Insert the storage card.
130010	The maximum nesting depth can be exhausted when, for example, a value change in a script results in the call of another script and the second script in turn has a value change that results in the call of yet a further script etc. The configured functionality is not supported.	Check the configuration.
140000	An online connection to the controller is established.	—
140001	The online connection to the controller was shut down.	—
140003	No tag updating or writing is executed.	Check the connection and if the controller is switched on. Check the parameter definitions in the Control Panel using "Set PG/PC interface". Restart the system.
140004	No tag update or write operations are executed because the access point or the module configuration is faulty.	Verify the connection and check if the controller is switched on. Check the access point or the module configuration (MPI, PPI, PROFIBUS) in the Control Panel with "Set PG/PC interface". Restart the system.
140005	No tag updating or writing is executed because the HMI device address is incorrect (possibly too high).	Use a different HMI device address. Verify the connection and check if the controller is switched on. Check the parameter definitions in the Control Panel using "Set PG/PC interface". Restart the system.
140006	No tag updating or writing is executed because the	Select a different baud rate in WinCC flexible (according

Number	Effect/cause	Remedy
	baud rate is incorrect.	to module, profile, communication peer, etc.).
140007	Tag are not updated or written because the bus profile is incorrect (see %1). The following parameter could not be written to the registry:: 1: Tslot 2: Tqui 3: Tset 4: MinTsdr 5: MaxTsdr 6: Trdy 7: Tid1 8: Tid2 9: Gap Factor 10: Retry Limit	Check the user-defined bus profile. Check the connection and if the controller is switched on. Check the parameter definitions in the Control Panel using "Set PG/PC interface". Restart the system.
140008	No tag updating or writing is executed because baud rate is incorrect. The following parameters could not be written to the registry: 0: General error 1: Wrong version 2: Profile cannot be written to the registry. 3: The subnet type cannot be written to the registry. 4: The Target Rotation Time cannot be written to the registry. 5: Faulty Highest Address (HSA).	Check the connection and if the controller is switched on. Check the parameter definitions in the Control Panel using "Set PG/PC interface". Restart the system.
140009	Tags are not updated or written because the module for S7 communication was not found.	Reinstall the module in the Control Panel using "Set PG/PC interface".
140010	No S7 communication partner found because the controller is shut down. DP/T: The option "PG/PC is the only master" is not set in the Control Panel under "Set PG/PC interface."	Switch the controller on. DP/T: If only one master is connected to the network, disable "PG/PC is the only master" in "Set PG/PC interface". If several masters are connected to the network, enable these. Do not change any settings, for this will cause bus errors.
140011	No tag updating or writing is executed because communication is down.	Check the connection and that the communication partner is switched on.
140012	There is an initialization problem (e.g. when WinCC flexible Runtime was closed in Task Manager). Or: Another application (e.g. STEP7) with different bus parameters is active and the driver cannot be started with the new bus parameters (transmission rate, for example).	Restart the HMI device. Or: Run WinCC flexible Runtime, then start your other applications.
140013	The MPI cable is disconnected and, thus, there is no power supply.	Check the connections.
140014	The configured bus address is in already in use by another application.	Edit the HMI device address in the controller configuration.
140015	Wrong transmission rate Or: Faulty bus parameters (e.g.HSA) Or: OP address > HSA or: Wrong interrupt vector (interrupt does not arrive at the driver)	Correct the relevant parameters.

Number	Effect/cause	Remedy
140016	The hardware does not support the configured interrupt.	Change the interrupt number.
140017	The set interrupt is in use by another driver.	Change the interrupt number.
140018	The consistency check was disabled by SIMOTION Scout. Only a corresponding note appears.	Enable the consistency check with SIMOTION Scout and once again download the project to the PLC.
140019	SIMOTION Scout is downloading a new project to the controller. Connection to the controller is canceled.	Wait until the end of the reconfiguration.
140020	The version in the controller and that of the project (FWX file) do not match. Connection to the controller is canceled	The following remedies are available: Download the current version to the PLC using SIMOTION Scout. Regenerate the project using WinCC flexible ES, close WinCC flexible Runtime and restart with a new configuration.
150000	No more data is read or written. Possible causes: <ul style="list-style-type: none"> <li>• The cable is defective.</li> <li>• The PLC does not respond, is defective, etc.</li> <li>• The wrong port is used for the connection.</li> <li>• System overload.</li> </ul>	Ensure that the cable is plugged in, the controller is operational, the correct interface is being used. Restart the system if the system alarm persists.
150001	Connection is up because the cause of the interruption has been eliminated.	—
160000	No more data is read or written. Possible causes: <ul style="list-style-type: none"> <li>• The cable is defective.</li> <li>• The PLC does not respond, is defective, etc.</li> <li>• The wrong port is used for the connection.</li> <li>• System overload.</li> </ul>	Ensure that the cable is plugged in, the controller is operational, the correct interface is being used. Restart the system if the system alarm persists.
160001	Connection is up because the cause of the interruption has been eliminated.	—
160010	No connection to the server because the server identification (CLS-ID) cannot be determined. Values cannot be read or written.	Check access rights.
160011	No connection to the server because the server identification (CLS-ID) cannot be determined. Values cannot be read or written.	Check, for example, if <ul style="list-style-type: none"> <li>• the server name is correct</li> <li>• the computer name is correct</li> <li>• the server is registered</li> </ul>
160012	No connection to the server because the server identification (CLS-ID) cannot be determined. Values cannot be read or written.	Check, for example, if <ul style="list-style-type: none"> <li>• the server name is correct</li> <li>• the computer name is correct</li> <li>• the server is registered</li> </ul> Note for advanced users: Interpret the value from HRESULT.
160013	The specified server was started as InProc server. This has not been released and may possibly lead to incorrect behavior because the server is running in the same process area as the WinCC flexible Runtime software.	Configure the server as OutProc Server or Local Server.

Number	Effect/cause	Remedy
160014	Only one OPC server project can be started on a PC/MP. An alarm is output when an attempt is made to start a second project. The second project has no OPC server functionality and cannot be located as an OPC server by external sources.	Do not start a second project with OPC server functionality on the computer.
170000	S7 diagnostics events are not indicated because it is not possible to log in to the S7 diagnostics functions at this device. The service is not supported.	—
170001	The S7 diagnostics buffer cannot be viewed because communication with the controller is shut down.	Set the controller to online mode.
170002	The S7 diagnostics buffer cannot be viewed because reading of the diagnostics buffer (SSL) was canceled with error.	—
170003	An S7 diagnostics event cannot be visualized. The system returns internal error %2.	—
170004	An S7 diagnostics event cannot be visualized. The system returns an internal error of error class %2, error number %3.	—
170007	It is not possible to read the S7 diagnostics buffer (SSL) because this operation was canceled with an internal error of class %2 and error code %3.	—
180000	A component/OCX received configuration data with a version ID which is not supported.	Install a newer component.
180001	System overload because too many actions running in parallel. Not all the actions can be executed, some are rejected.	Several remedies are available: <ul style="list-style-type: none"> <li>• Increase the configured cycle times or basic clock.</li> <li>• Generate the alarms at a slower rate (polling).</li> <li>• Initiate scripts and functions at greater intervals.</li> </ul> If the alarm appears more frequently: Restart the HMI device.
180002	The on-screen keyboard could not be activated. Possible causes: "TouchInputPC.exe" was not registered due to a faulty Setup.	Reinstall WinCC flexible Runtime.
190000	It is possible that the tag is not updated.	—
190001	The tag is updated after the cause of the last error state has been eliminated (return to normal operation).	—
190002	The tag is not updated because communication with the controller is down.	Select the system function "SetOnline" to go online.
190004	The tag is not updated because the configured tag address does not exist.	Check the configuration.
190005	The tag is not updated because the configured controller type does not exist for this tag.	Check the configuration.
190006	The tag is not updated because it is not possible to map the controller type in the data type of the tag.	Check the configuration.
190007	The tag value is not modified because the connection to the controller is interrupted or the tag is offline.	Set online mode or reconnect to the controller.

Number	Effect/cause	Remedy
190008	The threshold values configured for the tag have been violated, for example, by <ul style="list-style-type: none"> <li>• a value entered</li> <li>• a system function</li> <li>• a script</li> </ul>	Observe the configured or current threshold values of the tag.
190009	An attempt has been made to assign the tag a value which is outside the permitted range of values for this data type. For example, a value of 260 was entered for a byte tag or a value of -3 for an unsigned word tag.	Observe the range of values for the data type of the tags.
190010	Too many values are written to the tag (for example, in a loop triggered by a script). Values are lost because only up to 100 actions are saved to the buffer.	Increase the time interval between multiple write actions.
190011	Possible cause 1: The value entered could not be written to the configured controller tag because the high or low limit was exceeded. The system discards the entry and restores the original value. Possible cause 2: The connection to the controller was interrupted.	Make sure that the value entered lies within the range of values of the control tags. Check the connection to the PLC.
190012	It is not possible to convert a value from a source format to a target format, for example: An attempt is being made to assign a value to a counter that is outside the valid, PLC-specific value range. A tag of the type Integer should be assigned a value of the type String.	Check the range of values or the data type of the tags.
190100	The area pointer is not updated because the address configured for this pointer does not exist. Type 1 Warning alarms 2 Error alarms 3 Controller acknowledgment 4 HMI device acknowledgment 5 LED mapping 6 Trend request 7 Trend transfer 1 8 Trend transfer 2 No.: consecutive number shown in WinCC flexible ES.	Check the configuration.
190101	The area pointer is not updated because it is not possible to map the PLC type to the area pointer type. Parameter type and no.: see alarm 190100	—
190102	The area pointer is updated after the cause of the last error state has been eliminated (return to normal operation). Parameter type and no.: See alarm 190100.	—

Number	Effect/cause	Remedy
200000	Coordination is not executed because the address configured in the controller does not exist/is not set.	Change the address or set up the address in the controller.
200001	Coordination is canceled because the write access to the address configured in the PLC is not possible.	Change the address or set the address in the controller at an area which allows write access.
200002	Coordination is not carried out at the moment because the address format of the area pointer does not match the internal storage format.	Internal error
200003	Coordination can be executed again because the last error state is eliminated (return to normal operation).	—
200004	The coordination may not be executed.	—
200005	No more data is read or written. Possible causes: <ul style="list-style-type: none"> <li>• The cable is defective.</li> <li>• The PLC does not respond, is defective, etc.</li> <li>• System overload.</li> </ul>	Ensure that the cable is plugged in and the controller is operational. Restart the system if the system alarm persists.
200100	Coordination is not executed because the address configured in the controller does not exist/is not set.	Change the address or set up the address in the controller.
200101	Coordination is canceled because the write access to the address configured in the PLC is not possible.	Change the address or set the address in the controller at an area which allows write access.
200102	Coordination is not carried out at the moment because the address format of the area pointer does not match the internal storage format.	Internal error
200103	Coordination can be executed again because the last error state is eliminated (return to normal operation).	—
200104	The coordination may not be executed.	—
200105	No more data is read or written. Possible causes: <ul style="list-style-type: none"> <li>• The cable is defective.</li> <li>• The PLC does not respond, is defective, etc.</li> <li>• System overload.</li> </ul>	Ensure that the cable is plugged in and the controller is operational. Restart the system if the system alarm persists.
210000	Jobs are not processed because the address configured in the controller does not exist/has not been set up.	Change the address or set up the address in the controller.
210001	Jobs are not processed because read/write access to the address configured in the controller is not possible.	Change the address or set up the address in the controller in an area which allows read/write access.
210002	Jobs are not executed because the address format of the area pointer does not match the internal storage format.	Internal error
210003	The job buffer is processed again because the last error status has been eliminated (return to normal operation).	—
210004	It is possible that the job buffer will not be processed.	—
210005	A control request with an illegal number was initiated.	Check the controller program.

Number	Effect/cause	Remedy
210006	An error occurred while attempting to execute the control request. As a result, the control request is not executed. Observe the next/previous system alarms.	Check the parameters of the control request. Recompile the configuration.
220001	The tag is not downloaded because the associated communication driver / HMI device does not support the download of Boolean/discrete data types.	Change the configuration.
220002	The tag is not downloaded because the associated communication driver / HMI device does not support write access to the data type BYTE.	Change the configuration.
220003	The communication driver cannot be loaded. The driver may not be installed.	Install the driver by reinstalling WinCC flexible Runtime.
220004	Communication is down and no update data is transferred because the cable is not connected or defective etc.	Check the connection.
220005	Communication is up.	—
220006	The connection between the specified PLC and the specified port is active.	—
220007	The connection to the specified controller is interrupted at the specified port.	<p>Check if</p> <ul style="list-style-type: none"> <li>• the cable is plugged in</li> <li>• the controller is OK</li> <li>• the correct port is used</li> <li>• the configuration is OK (interface parameters, protocol settings, PLC address).</li> </ul> <p>Restart the system if the system alarm persists.</p>
220008	The communication driver cannot access or open the specified port. The port may be in use by another application or the port used is not available on the destination device. There is no communication with the controller.	<p>Close all the applications which access this port and restart the computer.</p> <p>Use another port of the system.</p>
230000	The value entered could not be accepted. The system discards the entry and restores the previous value. Either <ul style="list-style-type: none"> <li>• the value range has been exceeded</li> <li>• illegal characters have been entered</li> <li>• the maximum permitted number of users has been exceeded</li> </ul>	Enter a practical value or delete any unneeded users.
230002	The currently logged in user is not granted write access rights. The system therefore discards the input and restored the previous value.	Log on as a user with appropriate rights.
230003	Changeover to the specified screen failed because the screen is not available/configured. The current screen remains selected.	Configure the screen and check the screen selection function.
230005	The value range of the tag has been exceeded in the IO field. The original value of the tag is retained.	Observe the range of values for the tag when entering a value.

Number	Effect/cause	Remedy
230100	During navigation in the web browser, the system returned a message which may be of interest to the user. The web browser continues to run but may not (fully) show the new page.	Navigate to another page.
230200	The connection to the HTTP channel was interrupted due to an error. This error is explained in detail by another system alarm. Data is no longer exchanged.	Check the network connection. Check the server configuration.
230201	The connection to HTTP channel was established. Data is exchanged.	—
230202	WININET.DLL has detected an error. This error usually occurs when an attempt to connect to the server fails or the server refuses to connect because the client lacks the proper authorization. An unknown server certificate may also be the cause if the connection is encrypted by means of SSL. The alarm text provides details. This text is always in the language of the Windows installation because it is returned by the Windows OS. Process values are no longer exchanged.	Depending on the cause: When an attempt to connect fails or a timeout error occurs: <ul style="list-style-type: none"> <li>• Check the network connection and the network.</li> <li>• Check the server address.</li> <li>• Check if the web server is actually running on the destination computer.</li> </ul> Faulty authorization: <ul style="list-style-type: none"> <li>• The configured user name and/or password do not match those on the server. Establish consistency.</li> </ul> When the server certificate is rejected: Certificate signed by an unknown CA ( ): <ul style="list-style-type: none"> <li>• Either ignore this item in your project, or</li> <li>• Install a certificate that has been signed with a root certificate known to the client computer.</li> </ul> The date of the certificate is invalid: <ul style="list-style-type: none"> <li>• Either ignore this item in your project, or</li> <li>• Install a certificate with a valid date on the server.</li> </ul> Invalid CN (Common Name or Computer Name): <ul style="list-style-type: none"> <li>• Either ignore this item in your project, or</li> <li>• Install a certificate with a name that corresponds to that of the server address.</li> </ul>
230203	Although a connection can be made to the server, the HTTP server refuses to connect because <ul style="list-style-type: none"> <li>• WinCC flexible Runtime is not running on the server, or</li> <li>• the HTTP channel is not supported (503 Service unavailable).</li> </ul> Other errors can only occur if the web server does not support the HTTP channel. The language of the alarm text depends on the web server. Data is not exchanged.	Error 503 Service unavailable: Check if WinCC flexible Runtime is running on the server the HTTP channel is supported.
230301	An internal error has occurred. An English text explains the error in more detail. This may be caused by insufficient memory. OCX does not work.	—
230302	The name of the remote server cannot be resolved. The attempt to connect failed.	Check the configured server address. Check if the DNS service is available on the network.

Number	Effect/cause	Remedy
230303	The remote server is not running on the addressed computer. Wrong server address. The attempt to connect failed	Check the configured server address. Check if the remote server is running on the target computer.
230304	The remote server on the addressed computer is incompatible to VNCOCX. The attempt to connect failed.	Use a compatible remote server.
230305	The authentication has failed because the password is incorrect. The attempt to connect failed.	Configure the correct password.
230306	Error in the connection to the remote server. This may occur as a result of network problems. The attempt to connect failed.	Check if <ul style="list-style-type: none"> <li>the bus cable is plugged in</li> <li>there are network problems</li> </ul>
230307	The connection to the remote server was shut down because <ul style="list-style-type: none"> <li>the remote server was shut down, or</li> <li>the user instructed the server to close all connections.</li> </ul> The connection is closed.	—
230308	This alarm provides information on the connection status. An attempt is made to connect.	—
240000	WinCC flexible Runtime is operating in demo mode. You have no authorization or your authorization is corrupted.	Install the authorization.
240001	WinCC flexible Runtime is operating in demo mode. Too many tags are configured for the installed version.	Load an adequate authorization / powerpack.
240002	WinCC flexible Runtime is operating with a time-limited emergency authorization.	Restore the full authorization.
240003	Authorization failed. Without authorization, WinCC will run in demo mode.	Restart WinCC flexible Runtime or reinstall it.
240004	Error while reading the emergency authorization. WinCC flexible Runtime is operating in demo mode.	Restart WinCC flexible Runtime, install the authorization or repair the authorization (see Commissioning Instructions Software Protection).
240005	The Automation License Manager has detected an internal system fault. Possible causes: <ul style="list-style-type: none"> <li>A corrupt file</li> <li>A defective installation</li> <li>No free space for the Automation License Manager etc.</li> </ul>	Reboot the HMI device or PC. If this does not solve the problem, remove the Automation License Manager and install it again.
250000	The tag in the specified line in "Status force" is not updated because the address configured for this tag is not available.	Check the set address and then verify that the address is set up in the controller.
250001	The tag in the specified line in "Status force" is not updated because the controller type configured for this tag does not exist.	Check the set address.

Number	Effect/cause	Remedy
250002	The tag in the specified line in "Status force" is not updated because it is not possible to map the controller type in the tag type.	Check the set address.
250003	An attempt to connect to the PLC failed. The tags are not updated.	Check the connection to the PLC. Check that the controller is switched on and is online.
260000	An unknown user or an unknown password has been entered in the system. The current user is logged off from the system.	Log on to the system as a user with a valid password.
260001	The logged in user does not have sufficient authorization to execute the protected functions on the system.	Log on to the system as a user with sufficient authorization.
260002	This alarm is triggered by the system function "TrackUserChange".	—
260003	The user has logged off from the system.	—
260004	The user name entered into the user view already exists in the user administration.	Select another user name because user names have to be unique in the user administration.
260005	The entry is discarded.	Use a shorter user name.
260006	The entry is discarded.	Use a shorter or longer password.
260007	The login timeout value entered is outside the valid range of 0 to 60 minutes. The new value is discarded and the original value is retained.	Enter a login timeout value between 0 and 60 minutes.
260008	An attempt was made to read a PTProRun.pwl file created with ProTool V 6.0 in WinCC flexible. Reading the file was canceled due to incompatibility of the format.	—
260009	You have attempted to delete the user "Admin" or "PLC User". These users are fixed components of the user management and cannot be deleted.	If you need to delete a user, because perhaps you have exceeded the maximum number permitted, delete another user.
260012	The passwords entered in the "Change Password" dialog and the confirmation field are not identical. The password has not been changed. User will be logged off.	You have to log on to the system again. Then enter the identical password twice to be able to change the password.
260013	The password entered in the "Change Password" dialog is invalid because it is already in use. The password has not been changed. User will be logged off.	You have to log on to the system again. Then enter a new password that has not been used before.
260014	User has unsuccessfully attempted to log on 3 times in succession. The user has been locked out and assigned to group no. 0.	You can log on to the system with your correct password. Only an administrator can change the assignment to a group.
270000	A tag is not indicated in the alarm because it attempts to access an invalid address in the controller.	Check if the data area for the tag exists in the controller, the configured address is correct and the value range for the tag is correct.
270001	There is a device-specific limit as to how many alarms may be queued for output (see the operating instructions). This limit has been exceeded. The view no longer contains all the alarms. However, all alarms are written to the alarm buffer.	—

Number	Effect/cause	Remedy
270002	The view shows alarms of a log for which there is no data in the current project. Wildcards are output for the alarms.	Delete older log data if necessary.
270003	The service cannot be set up because too many devices want to use this service. A maximum of four devices may execute this action.	Reduce the number of HMI devices which want to use the service.
270004	Access to persistent buffer is not possible. Alarms cannot be restored or saved.	If the problems persist at the next startup, contact Customer Support (delete Flash).
270005	Persistent buffer damaged: Alarms cannot be restored.	If the problems persist at the next startup, contact Customer Support (delete Flash).
270006	Project modified: Alarms cannot be restored from the persistent buffer.	The project was generated and transferred new to the HMI device; The error should no longer occur when the device starts again.
270007	A configuration problem is preventing the restore (a DLL is missing, a directory is unknown, etc.).	Update the operating system and then transfer your project again to the HMI device.
280000	Connection is up because the cause of the interruption has been eliminated.	—
280001	No more data is read or written. Possible causes: <ul style="list-style-type: none"> <li>• The cable is defective.</li> <li>• The PLC does not respond, is defective, etc.</li> <li>• The wrong port is used for the connection.</li> <li>• System overload.</li> </ul>	Check if <ul style="list-style-type: none"> <li>• the cable is plugged in</li> <li>• the controller is OK</li> <li>• the correct port is used</li> </ul> Restart the system if the system alarm persists.
280002	The connection used requires a function block in the controller. The function block has responded. Communication is now enabled.	—
280003	The connection used requires a function block in the controller. The function block has not responded.	Check if <ul style="list-style-type: none"> <li>• the cable is plugged in</li> <li>• the controller is OK</li> <li>• the correct port is used</li> </ul> Restart the system if the system alarm persists. Remedy depends on the error code: <ol style="list-style-type: none"> <li>1: The function block must set the COM bit in the response container.</li> <li>2: The function block must not set the ERROR bit in the response container.</li> <li>3: The function block must respond within the specified time (timeout).</li> <li>4: Go online to the PLC.</li> </ol>
280004	The connection to the controller is interrupted. There is no data exchange at present.	Check the connection parameters in WinCC flexible. Ensure that the cable is plugged in, the controller is operational, the correct interface is being used. Restart the system if the system alarm persists.
290000	The recipe tag could not be read or written. It is assigned the start value. The alarm can be entered in the alarm buffer for up to four more failed tags if necessary. After that, alarm 290003 is output.	Check in the configuration that the address has been set up in the controller.

Number	Effect/cause	Remedy
290001	An attempt has been made to assign a value to a recipe tag which is outside the value range permitted for this type. The alarm can be entered in the alarm buffer for up to four more failed tags if necessary. After that, alarm 290004 is output.	Observe the value range for the tag type.
290002	It is not possible to convert a value from a source format to a target format. The alarm can be entered in the alarm buffer for up to four more failed recipe tags if necessary. After that, alarm 290005 is output.	Check the value range or type of the tag.
290003	This alarm is output when alarm number 290000 is triggered more than five times. In this case, no further separate alarms are generated.	Check in the configuration that the tag addresses have been set up in the controller.
290004	This alarm is output when alarm number 290001 is triggered more than five times. In this case, no further separate alarms are generated.	Observe the value range for the tag type.
290005	This alarm is output when alarm number 290002 is triggered more than five times. In this case, no further separate alarms are generated.	Check the value range or type of the tag.
290006	The threshold values configured for the tag have been violated by values entered.	Observe the configured or current threshold values of the tag.
290007	There is a difference between the source and target structure of the recipe currently being processed. The target structure contains an additional data recipe tag which is not available in the source structure. The data recipe tag specified is assigned its start value.	Insert the specified data recipe tag in the source structure.
290008	There is a difference between the source and target structure of the recipe currently being processed. The source structure contains an additional data recipe tag which is not available in the target structure and therefore cannot be assigned. The value is rejected.	Remove the specified data recipe tag in the specified recipe from the project.
290010	The storage location configured for the recipe is not permitted. Possible causes: Illegal characters, write protection, data carrier out of space or does not exist.	Check the configured storage location.
290011	The data record with the specified number does not exist.	Check the source for the number (constant or tag value).
290012	The recipe with the specified number does not exist.	Check the source for the number (constant or tag value).
290013	An attempt was made to save a data record under a data record number which already exists. The action is not executed.	The following remedies are available: <ul style="list-style-type: none"> <li>• Check the source for the number (constant or tag value).</li> <li>• First, delete the data record.</li> <li>• Change the "Overwrite" function parameter.</li> </ul>

Number	Effect/cause	Remedy
290014	The file specified to be imported could not be found.	Check: <ul style="list-style-type: none"> <li>• The file name</li> <li>• Ensure that the file is in the specified directory.</li> </ul>
290020	Message reporting that the download of data records from the HMI device to the PLC has started.	—
290021	Message reporting that the download of data records from the HMI device to the PLC was completed.	—
290022	Message reporting that the download of data records from the HMI device to the PLC was canceled due to an error.	Check in the configuration whether: <ul style="list-style-type: none"> <li>• The tag addresses are configured in the controller</li> <li>• The recipe number exists</li> <li>• The data record number exist</li> <li>• The "Overwrite" function parameter is set</li> </ul>
290023	Message reporting that the download of data records from the PLC to the HMI device has started.	—
290024	Message reporting that the download of data records from the PLC to the HMI device was completed.	—
290025	Message reporting that the download of data records from the PLC to the HMI device was canceled due to an error.	Check in the configuration whether: <ul style="list-style-type: none"> <li>• The tag addresses are configured in the controller</li> <li>• The recipe number exists</li> <li>• The data record number exist</li> <li>• The "Overwrite" function parameter is set</li> </ul>
290026	An attempt has been made to read/write a data record although the data record is not free at present. This error may occur in the case of recipes for which downloading with synchronization has been configured.	Set the data record status to zero.
290027	Unable to connect to the controller at present. As a result, the data record can neither be read nor written. Possible causes: No physical connection to the controller (no cable plugged in, cable is defect) or the controller is switched off.	Check the connection to the PLC.
290030	This alarm is output after you selected screen which contains a recipe view in which a data record is already selected.	Reload the data record from the storage location or retain the current values.
290031	While saving, it was detected that a data record with the specified number already exists.	Overwrite the data record or cancel the action.
290032	While exporting data records it was detected that a file with the specified name already exists.	Overwrite the file or cancel the process.
290033	Confirmation request before deleting data records.	—

Number	Effect/cause	Remedy
290040	A data record error with error code %1 that cannot be described in more detail occurred. The action is canceled. It is possible that the data record was not installed correctly on the controller.	Check the storage location, the data record, the "Data record" area pointer and if necessary, the connection to the controller. Restart the action after a short time. If the error persists, contact Customer Support. Forward the relevant error code to Customer Support.
290041	A data record or file cannot be saved because the storage location is full.	Delete files no longer required.
290042	An attempt was made to execute several recipe actions simultaneously. The last action was not executed.	Trigger the action again after waiting a short period.
290043	Confirmation request before storing data records.	—
290044	The data store for the recipe has been destroyed and is deleted.	—
290050	Message reporting that the export of data records has started.	—
290051	Message reporting that the export of data records was completed.	—
290052	Message reporting that the export of data records was canceled due to an error.	Ensure that the structure of the data records at the storage location and the current recipe structure on the HMI device are identical.
290053	Message reporting that the import of data records has started.	—
290054	Message reporting that the import of data records was completed.	—
290055	Message reporting that the import of data records was canceled due to an error.	Ensure that the structure of the data records at the storage location and the current recipe structure on the HMI device are identical.
290056	Error when reading/writing the value in the specified line/column. The action was canceled.	Check the specified line/column.
290057	The tags of the recipe specified were toggled from "offline" to "online" mode. Each change of a tag in this recipe is now immediately downloaded to the controller.	—
290058	The tags of the specified recipe were toggled from "offline" to "online" mode. Modifications to tags in this recipe are no longer immediately transferred to the controller but must be transferred there explicitly by downloading a data record.	—
290059	Message reporting that the specified data record was saved.	—
290060	Message reporting that the specified data record memory was cleared.	—
290061	Message reporting that clearing of data record memory was canceled due to an error.	—
290062	The data record number is above the maximum of 65536. This data record cannot be created.	Select another number.

Number	Effect/cause	Remedy
290063	This occurs with the system function "ExportDataRecords" when the parameter "Overwrite" is set to No. An attempt has been made to save a recipe under a file name which already exists. The export is canceled.	Check the "ExportDataRecords" system function.
290064	Message reporting that the deletion of data records has started.	—
290065	Message reporting that the deletion of data records has successfully completed.	—
290066	Confirmation request before deleting data records.	—
290068	Security request to confirm if all data records in the recipe should be deleted.	—
290069	Security request to confirm if all data records in the recipe should be deleted.	—
290070	The data record specified is not in the import file.	Check the source of the data record number or data record name (constant or tag value).
290071	During the editing of data record values, a value was entered which exceeded the low limit of the recipe tag. The entry is discarded.	Enter a value within the limits of the recipe tag.
290072	When editing data record values, a value was entered which exceeds the high limit of the recipe tag. The entry is discarded.	Enter a value within the limits of the recipe tag.
290073	An action (e.g. saving a data record) failed due to an unknown error. The error corresponds to the status alarm IDS_OUT_CMD_EXE_ERR in the large recipe view.	—
290074	While saving, it was detected that a data record with the specified number already exists but under another name.	Overwrite the data record, change the data record number or cancel the action.
290075	A data record with this name already exists. The data record is not saved.	Please select a different data record name.
300000	Faulty configuration of process monitoring (e.g. using PDiag or S7-Graph): More alarms are queued than specified in the specifications of the CPU. No further ALARM_S alarms can be managed by the PLC and reported to the HMI devices.	Change the controller configuration.
300001	ALARM_S is not registered on this controller.	Select a controller that supports the ALARM_S service.
310000	An attempt is being made to print too many reports in parallel. Only one log file can be output to the printer at a given time; the print job is therefore rejected.	Wait until the previous active log was printed. Repeat the print job if necessary.
310001	An error occurred on triggering the printer. The report is either not printed or printed with errors.	Evaluate the additional system alarms related to this alarm. Repeat the print job if necessary.

Number	Effect/cause	Remedy
320000	The movements have already been indicated by another device. The movements can no longer be controlled.	Deselect the movements on the other display units and select the motion control screen on the required display unit.
320001	The network is too complex. The faulty addresses cannot be indicated.	View the network in STL.
320002	No diagnostics alarm selected. The unit belonging to the alarm could not be selected.	Select a diagnostics alarm from the ZP_ALARM alarm screen.
320003	No alarms exists for the selected unit. The detail view cannot visualize any networks.	Select the defective unit from the overview screen.
320004	The required signal states could not be read by the PLC. The faulty addresses cannot be found.	Check the consistency between the configuration on the display unit and the PLC program.
320005	The project contains ProAgent elements which are not installed. ProAgent diagnostic functions cannot be performed.	In order to run the project, install the optional ProAgent package.
320006	You have attempted to execute a function which is not supported in the current constellation.	Check the type of the selected unit.
320007	No error-triggering addresses were found on the networks. ProAgent cannot indicate any faulty addresses.	Switch the detail screen to STL layout mode and check the status of the addresses and exclusion addresses.
320008	The diagnostic data stored in the configuration are not synchronized with those in the PLC. ProAgent can only indicate the diagnostic units.	Download the project to the HMI device again.
320009	The diagnostic data stored in the configuration are not synchronized with those in the PLC. The diagnostic screens can be operated as usual. ProAgent may be unable to show all diagnostic texts.	Download the project to the HMI device again.
320010	The diagnostic data stored in the configuration are not synchronized with those in STEP7. The ProAgent diagnostics data is not up-to-date.	Download the project to the HMI device again.
320011	A unit with the corresponding DB number and FB number does not exist. The function cannot be executed.	Check the parameters of the "SelectUnit" function and the units selected in the project.
320012	The "Step sequence mode" dialog is no longer supported.	Use the ZP_STEP step sequence screen from the corresponding standard project for your project. Instead of calling the Overview_Step_Sequence_Mode function, call the "FixedScreenSelection" function using ZP_STEP as the screen name.
320014	The selected controller cannot be evaluated for ProAgent. The alarm view assigned to the "EvaluateAlarmDisplayFault" system function could not be found.	Check the parameters of the "EvaluateAlarmDisplayFault" system function.
330022	Too many dialogs are open on the HMI device.	Close all dialogs you do not require on the HMI device.

# Index

## A

- Acoustic acknowledgement, 6-5
- Alarm
  - acknowledgment, 6-18, 6-21
  - Calling the infotext, 6-21
  - Editing, 6-18, 6-21
- Alarm buffer
  - In Runtime, 5-3
- Alarm classes
  - In Runtime, 5-2
  - Layout, 6-17, 6-19
- Alarm indicator, 6-16
  - Application, 6-16
  - Behavior, 6-16
  - In Runtime, 5-3
  - Layout, 6-16
  - Operation, 6-16
  - Operation with the mouse, 6-16
- Alarm log
  - In Runtime, 5-3
  - Scope of alarm logging, 5-5
- Alarm view, 6-17
  - Application, 6-17
  - Keyboard operation, 6-18
  - Layout, 6-17, 6-19
  - Mouse operation, 6-18
  - Operation, 6-17
  - Operator control components, 6-17
- Alarm window
  - In Runtime, 5-3
- Alarms
  - In Runtime, 5-2
- Alphanumerical screen keyboard, 6-6
- Alt layer
  - Screen keyboard, 6-6
- Application
  - Alarm indicator, 6-16
  - Alarm view, 6-17
  - Bar, 6-26
  - Button, 6-9
  - Clock, 6-32
  - Date/time field, 6-31
  - Gauge, 6-30

- Graphic I/O field, 6-14
- I/O field, 6-12
- Recipe view, 6-21
- Simple alarm view, 6-19
- Simple recipe view, 6-24
- Simple user view, 6-35
- Slider control, 6-29
- Sm@rtClient view, 6-42
- Status/control, 6-38
- Switch, 6-10
- Symbol, 6-37
- Symbolic I/O field, 6-15
- Trend view, 6-27
- User view, 6-33
- User view, 6-33
- Authorization
  - In Runtime, 5-29

## B

- Bar, 6-26
  - Application, 6-26
  - Layout, 6-26
  - Operation, 6-26
- Behavior
  - Alarm indicator, 6-16
  - Button, 6-9
  - Date/time field, 6-31
  - Graphic I/O field, 6-14
  - HTML browser, 6-41
  - I/O field, 6-12
  - Recipe view, 6-22
  - Simple recipe view, 6-25
  - Sm@rtClient view, 6-43
  - Switch, 6-11
  - Symbol, 6-38
  - Symbolic I/O field, 6-15
- Button, 6-9
  - Application, 6-9
  - Behavior, 6-9
  - Layout, 6-9
  - Operation, 6-9
  - Operation with the keyboard, 6-9
  - Operation with the mouse, 6-9

**C**

## Calling

- Operator note: touch screen device, 6-8
- Operator note: Touch screen device, 6-6
- Operator note:screen keyboard, 6-7
- Operator note:screen keyboard, 6-6
- Operator note:system function, 6-8
- Operator note:touch screen device, 6-7
- Remote control, 6-43
- Remote monitoring, 6-43

## Changing

- Recipe data record in Runtime, 5-19

## Clock, 6-32

- Application, 6-32
- Layout, 6-32
- Operation, 6-32

## Closing

- Remote control and monitoring, 6-44
- Runtime, 4-9

## Configuration, 5-10

- Of recipes, 5-10

## Copy

- Recipe data record in Runtime, 5-19

## create

- Recipe record on the HMI device, 5-19

## CSV file, 5-9

**D**

## Data log

- In Runtime, 5-5

## Data mailbox

- For recipes, 5-11

## Data record

- Exporting, 5-22
- Importing, 5-22

## Data set

- reading, 5-21
- Transfer, 5-21

## Date/time field, 6-31

- Application, 6-31
- Behavior, 6-31
- Layout, 6-31
- Operation, 6-31
- Operation with the keyboard, 6-32
- Operation with the mouse, 6-32

## Deleting

- Recipe data record in Runtime, 5-20

## Direct key, 6-4

**E**

## Editing, 5-9

- Recipe data record in WinCC flexible, 5-9
- Recipe record, 5-9

## Enter

- Alphanumeric values:touch panel, 6-6
- Numeric values:touch panel, 6-7

## Entering alphanumeric values

- Touch screen device, 6-6

## Entering numeric values

- Touch screen device, 6-7

## exporting

- User data, 5-30

## Exporting

- Recipe, 5-22
- Recipe record, 5-22

**F**

## Feedback

- Acoustic, 6-5
- Optical, 6-5
- With touch operation, 6-4

## Forcing

- Permissions in remote operation, 6-42

## Full-screen mode

- Setting, 4-4

## Functional scope

- Dependencies, 2-1
- WinCC flexible Runtime, 2-1

**G**

## Gauge, 6-30

- Application, 6-30
- Layout, 6-31
- Operation, 6-31

## General operation

- Touch screen device, 6-4

## Graphic I/O field, 6-14

- Application, 6-14
- Behavior, 6-14
- Operation, 6-14
- Operation with the keyboard, 6-14
- Operation with the mouse, 6-14

**H**

## Hide

- Screen keyboard, 6-6, 6-7

## HTML browser

- Behavior, 6-41

Operator control components, 6-41

## I

I/O field, 6-12  
 Application, 6-12  
 Behavior, 6-12  
 Layout, 6-12  
 Operation, 6-12  
 Operation with the keyboard, 6-13  
 Operation with the mouse, 6-13  
 importing  
 User data, 5-30  
 Importing  
 Recipe, 5-22  
 Recipe record, 5-22  
 Installation  
 on the PC, 4-1

## K

Keyboard layers, 6-6  
 Keyboard operation  
 Simple user view, 6-36  
 Keyboard operation  
 Alarm view, 6-18  
 Operation with the keyboard, 6-11  
 Recipe view, 6-34  
 Simple recipe view, 6-25  
 Keys  
 Remote control, 6-42

## L

Layout  
 Alarm indicator, 6-16  
 Alarm view, 6-17, 6-19  
 Bar, 6-26  
 Button, 6-9  
 Clock, 6-32  
 Date/time field, 6-31  
 Gauge, 6-31  
 I/O field, 6-12  
 Simple recipe view, 6-24  
 Simple user view, 6-35  
 Slider control, 6-29  
 Sm@rtClient view, 6-42  
 Status/control, 6-39  
 Switch, 6-10  
 Trend view, 6-27  
 User view, 6-33  
 LED control, 5-31

Licensing  
 General information, 1-1  
 Load  
 Recipe data record in Runtime, 5-19  
 Log  
 In Runtime, 5-4  
 Memory options, 5-4  
 Logging  
 Scope of alarm logging, 5-5  
 Logoff time  
 Exporting/importing, 5-30  
 In Runtime, 5-30

## M

Modifying recipe structures, 5-23  
 Monitoring mode  
 Sm@rtClient view, 6-43  
 Mouse operation  
 Alarm view, 6-18  
 Simple recipe view, 6-25  
 Simple user view, 6-36  
 User view, 6-34

## N

Numerical screen keyboard, 6-7

## O

Objects in Runtime  
 Overview, 5-1  
 Operating recipes  
 Copying a recipe data record, 5-19  
 Creating recipe records, 5-19  
 Data record transfer, 5-21  
 Delete recipe data record, 5-20  
 Load recipe data record, 5-19  
 Modify recipe record, 5-19  
 Modifying the recipe structure, 5-23  
 Read recipe data record, 5-21  
 Operating the touch screen device, 6-4  
 Operation  
 Alarm indicator, 6-16  
 Alarm view, 6-17  
 Bar, 6-26  
 Button, 6-9  
 Clock, 6-32  
 Date/time field, 6-31  
 Gauge, 6-31  
 Graphic I/O field, 6-14  
 I/O field, 6-12

- Recipe view, 6-22
- Runtime using the keyboard, 6-2
- Runtime with mouse, 6-3
- Simple alarm view, 6-19
- Simple recipe view, 6-24
- Simple user view, 6-36
- Slider control, 6-29
- Status/control, 6-39
- Switch, 6-10
- Symbol, 6-37
- Symbolic I/O field, 6-15
- Touch objects, 6-4
- Touch screen device, 6-4
- Trend view, 6-27
- Operation feedback, 6-4
- Operation with the keyboard
  - Button, 6-9
  - Date/time field, 6-32
  - Graphic I/O field, 6-14
  - I/O field, 6-13
  - Recipe view, 6-23
  - Simple alarm view, 6-20
  - Slider control, 6-30
  - Sm@rtClient view, 6-43
  - Status/control, 6-40
  - Symbolic I/O field, 6-15
  - Trend view, 6-28
- Operation with the mouse
  - Alarm indicator, 6-16
  - Button, 6-9
  - Date/time field, 6-32
  - Graphic I/O field, 6-14
  - I/O field, 6-13
  - Recipe view, 6-23
  - Simple alarm view, 6-20
  - Slider control, 6-30
  - Sm@rtClient view, 6-43
  - Status/control, 6-39
  - Switch, 6-11
  - Symbolic I/O field, 6-15
  - Trend view, 6-28
- Operator control components
  - Alarm view, 6-17
  - HTML browser, 6-41
  - Recipe view, 6-22
  - Simple alarm view, 6-20
  - Simple recipe view, 6-25
  - Status/control, 6-39
  - Trend view, 6-28
- Operator note
  - calling:screen keyboard, 6-6, 6-7
  - Calling:system function, 6-8
  - Calling:Touch screen device, 6-6, 6-7, 6-8
- Optical feedback, 6-5

## P

- Password
  - Exporting/importing, 5-30
  - In Runtime, 5-29
- Permission
  - forcing (remote operation), 6-42
- Picture
  - Printing, 5-31
- Printing
  - Alarms, 5-31
  - Picture, 5-31
  - Protocol, 5-27
  - Runtime, 5-31
- Program switching
  - disabling for Runtime, 4-4
- Protocol
  - In Runtime, 5-27
  - Printing, 5-27

## R

- Recipe, 5-7, 5-8
  - Basic principles, 5-7
  - Configuration options, 5-10
  - Configuration settings, 5-10
  - Data set, 5-8
  - Display in Runtime, 5-6, 5-16
  - Exporting, 5-22
  - Importing, 5-22
  - Layout, 5-7
  - Synchronizing recipe tags, 5-20
- Recipe record, 5-8
  - Changing, 5-19
  - Copy, 5-19
  - Create on the HMI device, 5-19
  - Deleting, 5-20
  - Editing in WinCC flexible, 5-9
  - Exporting, 5-22
  - Importing, 5-22
  - Layout, 5-7
  - Load, 5-19
  - synchronizing, 5-20
  - Transfer, 5-9
  - Transfer options, 5-9
- Recipe screen, 5-17
  - Overview, 5-17
- Recipe tags
  - synchronizing, 5-20
- Recipe view
  - Application, 6-21
  - Behavior, 6-22
  - Hotkeys, 6-23
  - Keyboard operation, 6-34

- Operation, 6-22
  - Operation with the keyboard, 6-23
  - Operation with the mouse, 6-23
  - Recipes view, 5-16, 6-21
    - Behavior with screen change, 5-18
    - Operation with function keys, 5-18
    - Operator control components, 6-22
    - Overview, 5-16
  - Remote control
    - accessing, 6-43
    - Closing, 6-44
    - Forcing permission, 6-42
  - Remote monitoring
    - accessing, 6-43
    - Closing, 6-44
  - Runtime
    - Change language, 6-1
    - Operation, 6-1
    - Operation with the keyboard, 6-2
    - Operation with the mouse, 6-3
- S**
- Screen keyboard, 6-5
    - Alphanumerical, 6-6
    - Numerical, 6-7
  - Screen objects
    - In Runtime, overview, 5-1
  - Screen saver
    - for Runtime, 4-4
  - Security
    - In Runtime, 5-29
  - Setting
    - in the Runtime configuration, 4-4
  - Shift layer
    - Screen keyboard, 6-6
  - Shift+Alt-Gr layer
    - Screen keyboard, 6-6
  - Simple alarm view, 6-19
    - Application, 6-19
    - Operation, 6-19
    - Operation with the keyboard, 6-20
    - Operation with the mouse, 6-20
    - Operator control components, 6-20
  - Simple recipe view, 6-24
    - Application, 6-24
    - Behavior, 6-25
    - Hotkeys, 6-25
    - Keyboard operation, 6-25
    - Layout, 6-24
    - Mouse operation, 6-25
    - Operation, 6-24
    - Operator control components, 6-25
  - Simple user view, 6-35
    - Application, 6-35
    - Changing user data, 6-37
    - Keyboard operation, 6-36
    - Layout, 6-35
    - Mouse operation, 6-36
    - Operation, 6-36
  - Slider control, 6-29
    - Application, 6-29
    - Layout, 6-29
    - Operation, 6-29
    - Operation with the keyboard, 6-30
    - Operation with the mouse, 6-30
  - Sm@rtClient view, 6-42
    - Application, 6-42
    - Behavior, 6-43
    - Layout, 6-42
    - Monitoring mode, 6-43
    - Operation with the keyboard, 6-43
    - Operation with the mouse, 6-43
  - Softkey
    - Remote control, 6-42
  - Standard layer
    - Screen keyboard, 6-6
  - Status/control, 6-38
    - Application, 6-38
    - Layout, 6-39
    - Operation with the keyboard, 6-40
    - Operation with the mouse, 6-39
    - Operator control components, 6-39
  - Status/control
    - Operation, 6-39
  - Switch, 6-10
    - Application, 6-10
    - Behavior, 6-11
    - Layout, 6-10
    - Operation, 6-10
    - Operation with the keyboard, 6-11
    - Operation with the mouse, 6-11
  - Symbol
    - Application, 6-37
    - Behavior, 6-38
    - Operation, 6-37
  - Symbolic I/O field, 6-15
    - Application, 6-15
    - Behavior, 6-15
    - Operation, 6-15
    - Operation with the keyboard, 6-15
    - Operation with the mouse, 6-15
  - Synchronization
    - With controller, 5-11
  - synchronizing
    - Recipe record, 5-20
  - System alarms

- Meaning, 7-1
- Parameter, 7-1
- System function, 5-9
  - to transfer of recipe data records, 5-9
- System requirements
  - for a PC, 3-1

## T

- Tags
  - In Runtime, 5-4
- Time zone
  - Setting, 4-5
- Touch objects
  - Operating, 6-4
- Transfer, 5-9
  - Of recipe data records, 5-9
- Trend view, 6-27
  - Application, 6-27
  - Layout, 6-27
  - Operation, 6-27
  - Operation with the keyboard, 6-28
  - Operation with the mouse, 6-28
  - Operator control components, 6-28

## U

- User data
  - Exporting/importing, 5-30
- User group
  - In Runtime, 5-29
- User view, 6-33
  - Application, 6-33
  - Change group, 6-35
  - Changing user data, 6-34
  - Create user, 6-35
  - Export user data, 6-34
  - Import user data, 6-34
  - Layout, 6-33
  - Mouse operation, 6-34
- Users
  - In Runtime, 5-29

## W

- WinCC flexible
  - Basics, 1-1
- WinCC flexible Runtime
  - Closing, 4-9
  - Functional scope, 2-1
  - System requirements for a PC, 3-1