

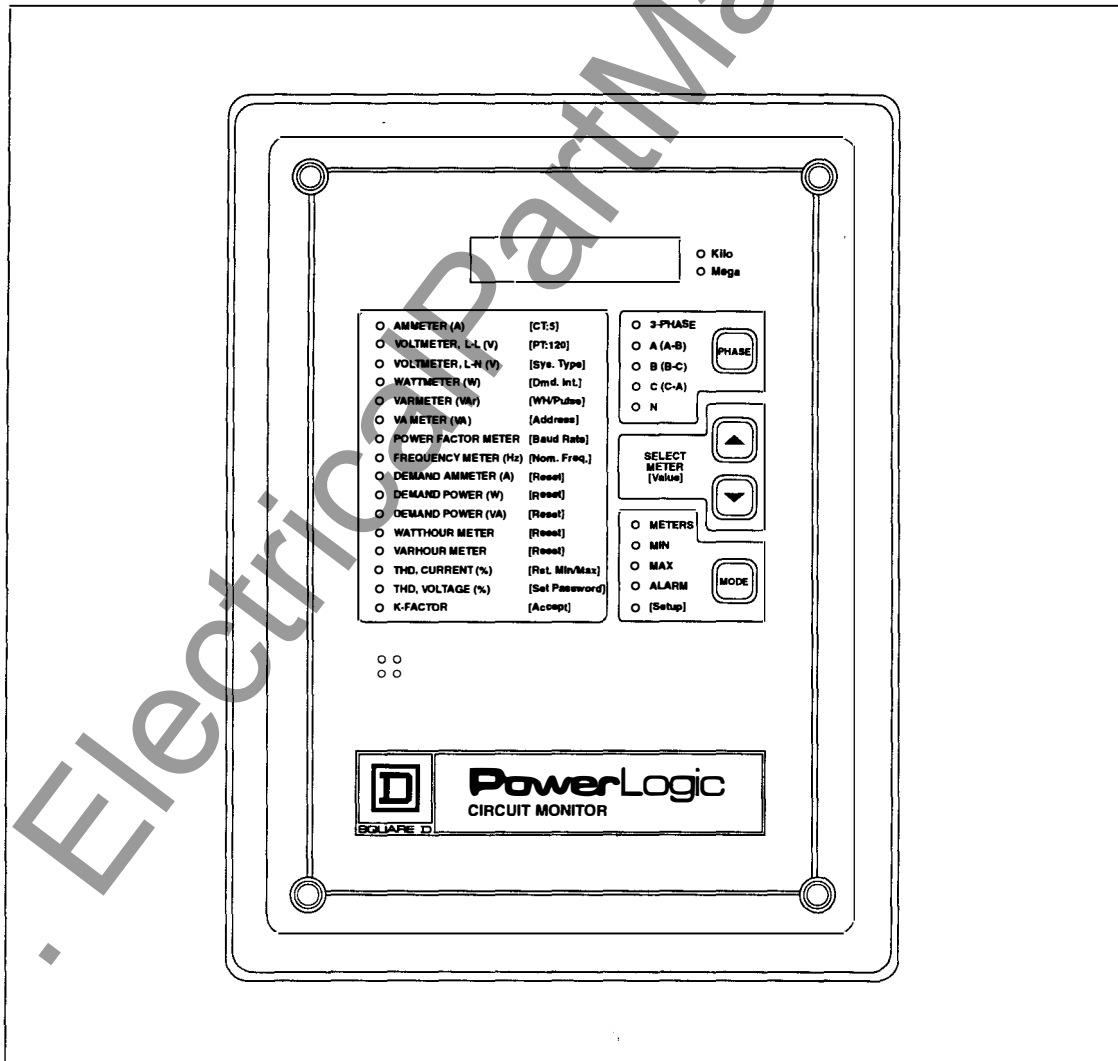

PowerLogic[®]

Circuit Monitor

Series 2000



NOTICE

Read these instructions carefully and look at the equipment to become familiar with the device before trying to install, operate, or maintain it. The following special messages may appear throughout this manual to warn of potential hazards or to call attention to information that clarifies or simplifies a procedure.

DANGER

Used where there is hazard of severe bodily injury or death. Failure to follow a "DANGER" instruction *will* result in *severe* bodily injury or death.

WARNING

Used where there is hazard of bodily injury or death. Failure to follow a "WARNING" instruction may result in bodily injury or death.

CAUTION

Used where there is hazard of equipment damage. Failure to follow a "CAUTION" instruction may result in damage to equipment.

NOTE

Provides additional information to clarify or simplify a procedure.

PLEASE NOTE: Electrical equipment should be serviced only by qualified electrical maintenance personnel, and this document should not be viewed as sufficient for those who are not otherwise qualified to operate, service, or maintain the equipment discussed. Although reasonable care has been taken to provide accurate and authoritative information in this document, no responsibility is assumed by Square D for any consequences arising out of the use of this material.

FCC NOTICE: This equipment complies with the requirements in Part 15 of FCC rules for a Class A computing device. Operation of this equipment in a residential area may cause unacceptable interference to radio and TV reception, requiring the operator to take whatever steps are necessary to correct the interference.

TECHNICAL SUPPORT

For technical support, contact the Power Monitoring and Control Systems Technical Support Center. Hours are 7:30 A.M. to 4:30 P.M., Central Time, Monday through Friday.

Phone: (615) 459-8552 Fax:(615) 459-4294

CONTENTS

CHAPTER 1—INTRODUCTION	1
What is the Circuit Monitor?	1
Safety Precautions	4
Using This Manual	5
Topics Not Covered Here	5
Notational Conventions	5
CHAPTER 2—HARDWARE DESCRIPTION	6
Front Panel	6
Rear Connections	8
CHAPTER 3—INSTALLATION	9
Mounting the Circuit Monitor	10
Wiring CTs, VTs, and Control Power	12
Wiring Multiple Circuit Monitors to a Single Set of VTs/CPT	17
Deriving Control Power from Phase VT Inputs	18
Grounding the Circuit Monitor	19
Communications Wiring	20
Connecting to a System Display	21
Connecting to a Personal Computer	22
Connecting to a POWERLOGIC Network Interface Module	23
Connecting to a SY/MAX Programmable Controller	24
Length of the Communications Link	25
Daisy-Chaining POWERLOGIC Devices	26
Terminating the Communications Link	27
Biasing the Communications Link	28
CHAPTER 4—FRONT PANEL OPERATION	29
The Setup Mode	30
The Configuration Option	30
The Resets Option	30
The Alarm/Relay Option	30
The Diagnostics Option	30
Choosing a Setup Option	31
How the Buttons Work	31
Configuring the Circuit Monitor	32
Factory Defaults	32
General Configuration Procedure	32
Viewing Configuration Data in Protected Mode	35
Setting the Master Password	36
Setting the CT Ratios	37
Setting the PT Ratio	38
Setting the System Type	39
Setting the Demand Interval	39
Setting the Watthour/Pulse Output	41

Setting the Device Address	42
Setting the Baud Rate	43
Setting the Nominal Frequency	44
Resetting Demand, Energy, and Min/Max Values	45
Performing Resets Using the Resets Option	46
Setting Up Alarm/Relay Functions	47
General Setup Procedure	48
Detailed Setup Procedure	49
Viewing Active Alarms	52
Viewing the Priority 1 Log	53
Clearing the Priority 1 Log	54
CHAPTER 5—METERING CAPABILITIES	55
Real-Time Readings	55
Min/Max Values	56
Demand Readings	58
Demand Power Calculation Methods	58
Predicted Demand	59
Peak Demands	59
Energy Readings	60
Power Analysis Values	61
CHAPTER 6—INPUT/OUTPUT CAPABILITIES	62
Input/Output Modules	62
Status Inputs	63
Demand Synch Pulse Input	20
Pulse Demand Metering	64
Analog Inputs	67
Relay Output Operating Modes	69
Mechanical Relay Outputs	71
Setpoint Controlled Relay Functions	72
Solid State KYZ Pulse Output	73
2-Wire Pulse Initiator	73
3-Wire Pulse Initiator	74
Calculating the Watthour-per-pulse Value	75
Analog Outputs	76
CHAPTER 7—ALARM FUNCTIONS	78
Setpoint Driven Alarms	78
Protective Functions	80
CHAPTER 8—LOGGING	84
Event Logging	84
Event Log Storage	84
Data Logging	85
Alarm Driven Data Log Entries	85

Organizing Data Log Files	85
Storage Considerations	86
Maintenance Log	87
CHAPTER 9—WAVEFORM CAPTURE	88
4-Cycle Waveform Capture	88
Manual Waveform Capture	88
Automatic Waveform Capture	88
Waveform Storage	90
12-Cycle Event Capture	91
Manual Event Capture	91
Automatic Event Capture—High-speed Trigger	91
Automatic Event Capture—Setpoint Controlled	93
12-Cycle Event Capture Storage	94
CHAPTER 10—DISTURBANCE MONITORING	95
Introduction	95
High-Speed Events	96
CHAPTER 11—MAINTENANCE AND TROUBLESHOOTING	97
Maintenance	97
Battery-Backed RAM	97
Troubleshooting	98
Getting Technical Support	99
CHAPTER 12—ADVANCED TOPICS	100
The Command Interface	101
Command Codes	101
Operating Relays Using the Command Interface	103
Setting Up Relays for Remote (External) Control	103
Energizing Relays	103
De-Energizing Relays	103
Setting Up Relays for Circuit Monitor (Internal) Control	104
Overriding an Output Relay	104
Releasing an Over-riden Relay	105
Setting Scale Factors For Extended Metering Ranges	106
Setting The Date and Time Using the Command Interface	109
Memory Allocation	110
Memory Example	112
How Power Factor is Stored	112
Changing the VAR/Power Factor Sign Convention	113
Conditional Energy	114
Command Interface Control	114
Status Input Control	115
Incremental Energy	115
Using Incremental Energy	116

Changing the Demand Calculation Method	117
Changing to the Block/Rolling Method	117
Setting Up a Demand Synch Pulse Input	117
Controlling the Demand Interval Over the Communications Link	118

APPENDICES

Appendix A—Circuit Monitor Dimensions	119
Appendix B—Installing and Wiring Optional I/O Modules	121
Appendix C—Installing the Optional Voltage/Power Module	131
Appendix D—Communication Cable Pinouts	135
Appendix E—Abbreviated Register Listing	136
Appendix F—Specifications	155
Appendix G—Calculating Log File Sizes	157
Appendix H—Installing Terminal Strip Covers	158
Appendix I—Alarm Conditions and Alarm Codes	159
Appendix J—Using the Optical Communications Interface	166
Appendix K—Reading and Writing Registers from the Front Panel	168

FIGURES

2-1 Circuit Monitor front panel	7
2-2 Back of the Circuit Monitor	8
3-1 Panel preparation	11
3-2 Circuit Monitor mounted in electrical panel	11
3-3 3-phase, 3-wire delta connection	13
3-4 3-phase, 4-wire wye, ground connection	14
3-5 3-phase, 4-wire wye, ground connection, metered neutral	15
3-6 DC control power connections	16
3-7 Circuit Monitors connected to one set of VTs and one CPT	17
3-8 Deriving control power from phase VT inputs	18
3-9 Grounding the Circuit Monitor	19
3-10 Circuit Monitors connected to a System Display for Circuit Monitors	21
3-11 POWERLOGIC devices connected directly to a personal computer	22
3-12 POWERLOGIC devices connected to a PNIM	23
3-13 POWERLOGIC devices connected to a SY/MAX programmable controller	24
3-14 Daisy-chaining the RS-485 communications terminals	26
3-15 Placement of terminator when the last device on the link is a Circuit Monitor	27
3-16 Multipoint communications adapter connected to a PNIM	28
4-1 Choosing a setup option	31
4-2 Flowchart for front panel configuration	34
4-3 Alarm/Relay setup	48
5-1 Power factor min/max example	57
5-2 Default sign convention	57
5-3 Optional sign convention	57
6-1 Demand synch pulse timing	64
5-7 2-wire pulse train	69
5-8 3-wire pulse train	69

6-2	Pulse demand metering example	66
6-3	Analog input example	68
6-4	2-wire pulse train	74
6-5	3-wire pulse train	74
6-6	Analog output example	77
7-1	Sample event log entry	79
7-2	How the Circuit Monitor handles setpoint-driven alarms	79
9-1	Flowchart illustrating automatic waveform capture	89
9-2	Status input S2 connected to external high-speed relay	92
9-3	12-Cycle event capture example	93
12-1	Memory allocation example (CM-2350 and higher)	111
12-2	Power factor register format	112
12-3	Default sign convention	113
12-4	Optional sign convention	113
B-1	Circuit Monitor dimensions with I/O modules installed	122
B-2	Installing an IOM-11, IOM-18, or IOM-44 module	123
B-3	Installing an IOM-4411 or IOM-4444 module	124
B-4	Typical status input connections	125
B-5	Typical relay output connections	125
B-6	Pulse output	126
B-7	Connections for 0-5 Vdc input signal	127
B-8	Connections for 4-20 mA input signal	127
B-9	Typical analog output wiring connections	128
B-10	I/O Module Terminal Labels	129
B-11	IOM-4411 and IOM-4444 silk screens	130
C-1	Voltage/power module dimensions	132
C-2	Mounting the voltage/power module on the back of the Circuit Monitor	132
C-3	Terminal connections between Circuit Monitor and voltage/power module	133
C-4	Wiring the voltage/power module.....	134
H-1	Installing terminal strip covers	158
J-1	Correct placement of the OCI-2000	167

TABLES

1-1	Summary of Circuit Monitor instrumentation	3
1-2	Class 3020 Circuit Monitors	3
1-3	Circuit Monitor feature comparison	3
3-1	Typical Circuit Monitor mounting locations	10
3-2	Supported system wiring connections	12
3-3	Maximum distances of communications link at varying baud rates	25
4-1	Factory defaults for front panel configuration parameters	32
4-2	Supported system wiring connections	38
4-3	Maximum distances of comms link at varying baud rates	43
5-1	Real-time readings	55
5-2	Demand readings	58
5-3	Energy readings	60
5-4	Power analysis values	61

6-1	Input/Output Modules	62
8-1	Values stored in the maintenance log	87
12-1	Memory configuration example	112
B-1	Input/Output Modules	121

CHAPTER 1—INTRODUCTION

CHAPTER CONTENTS

This chapter offers a general description of the Circuit Monitor, describes important safety precautions, tells how to best use this manual, and lists related documents. Topics are discussed in the following order:

What is the Circuit Monitor?	1
Safety Precautions	4
Using This Manual	5
Topics Not Covered Here	5
Notational Conventions	5

WHAT IS THE CIRCUIT MONITOR?

The POWERLOGIC® Circuit Monitor is a multi-function, digital instrumentation, data acquisition and control device. It can replace a variety of meters, relays, transducers and other components. The Circuit Monitor is equipped with RS-485 communications for integration into a POWERLOGIC power monitoring and control system.

The Circuit Monitor is a true rms meter capable of exceptionally accurate measurement of highly nonlinear loads. A sophisticated sampling technique enables accurate, true rms measurement through the 31st harmonic.

Over 50 metered values plus extensive minimum and maximum data can be viewed from the six-digit LED display. Table 1-1 on page 3 provides a summary of Circuit Monitor instrumentation.

The Circuit Monitor is available in several models to meet a broad range of power monitoring and control applications. Table 1-2 on page 3 lists the Circuit Monitor models. Table 1-3 compares the features available by model.

Circuit Monitor capabilities can be expanded using add-on modules that mount on the back of the Circuit Monitor. A voltage/power module and several input/output modules are available. See Chapter 6—I/O Capabilities for a description of the available I/O modules.

Using POWERLOGIC application software, users can upgrade Circuit Monitor firmware through either the RS-485 or front panel optical communications ports. This feature can be used to keep all Circuit Monitors up to date with the latest system enhancements.

Some of the Circuit Monitor's many features include:

- True rms Metering (31st Harmonic)
- Accepts Standard CT and PT Inputs
- High Accuracy—0.2% Current and Voltage
- Over 50 Displayed Meter Values

**What is the Circuit Monitor?
(cont.)**

- Min/Max Displays for Metered Data
- Power Quality Readings—THD, K-Factor, Crest Factor
- On-board Clock/Calendar
- Easy Front Panel Setup (Password Protected)
- RS-485 Communications Standard
- Front Panel, Optical Communications Port Standard
- Modular, Field-Installable, Digital I/O
- I/O Modules Support Programmable KYZ Pulse Output
- Setpoint-Controlled Alarm/Relay Functions
- On-board Event and Data Logging
- Waveform Capture
- High-speed, Triggered, 12-Cycle Event Capture
- Downloadable Firmware
- System Connections
 - 3-Phase, 3-Wire Delta
 - 3-Phase, 4-Wire Wye
 - Metered or Calculated Neutral
 - Other Metering Connections
- Optional Voltage/Power Module for Direct Connection to 480Y/277V
- Wide Operating Temperature Range, Standard (-25 to +70° C)

Table 1-1
Summary of Circuit Monitor Instrumentation

Real-Time Readings	Energy Readings
<ul style="list-style-type: none"> • Current (per phase, N, G, 3Ø) • Voltage (L-L, L-N) • Real Power (per phase, 3Ø) • Reactive Power (per phase, 3Ø) • Apparent Power (per phase, 3Ø) • Power Factor (per phase, 3Ø) • Frequency • Temperature (internal ambient)* • THD (current and voltage) • K-Factor (per phase) 	<ul style="list-style-type: none"> • Accumulated Energy, Real • Accumulated Energy, Reactive • Accumulated Energy, Apparent* • Bidirectional Readings*
	Power Analysis Values*
	<ul style="list-style-type: none"> • Crest Factor (per phase) • K-Factor Demand (per phase) • Displacement Power Factor (per phase, 3Ø) • Fundamental Voltages (per phase) • Fundamental Currents (per phase) • Fundamental Real Power (per phase) • Harmonic Power • Unbalance (current and voltage) • Phase Rotation
Demand Readings	
<ul style="list-style-type: none"> • Demand Current (per-phase present, peak) • Average Power Factor (3Ø total) • Demand Real Power (3Ø total) • Demand Reactive Power (3Ø total)* • Demand Apparent Power (3Ø total) • Coincident Readings* • Predicted Demands* 	<p>* Available via communications only.</p>

Table 1-2
Class 3020 Circuit Monitors

Type	Description
CM-2050	Instrumentation, 1% accuracy
CM-2150	Instrumentation, 0.2% accuracy
CM-2250	Instrumentation, waveform capture, 0.2% accuracy
CM-2350	Instrumentation, waveform capture, extended memory, 0.2% accuracy

Table 1-3
Circuit Monitor Feature Comparison

Feature	CM-2050	CM-2150	CM-2250	CM-2350
Full Instrumentation	x	x	x	x
RS-485 Comm Port	x	x	x	x
Front Panel Optical Comm Port	x	x	x	x
1% Accuracy Class	x			
0.2% Accuracy Class		x	x	x
Alarm/Relay Functions		x	x	x
On-board Data Logging		x	x	x
Downloadable Firmware		x	x	x
Date/Time for Each Min/Max		x	x	x
Waveform Capture			x	x
12-Cycle Event Capture			x	x
Extended Memory				x
Surge/Sag Detection				x

SAFETY PRECAUTIONS

DANGER

HAZARD OF BODILY INJURY OR EQUIPMENT DAMAGE.

- Only qualified electrical workers should install this equipment. Such work should be performed only after reading this entire set of instructions.
- The successful operation of this equipment depends upon proper handling, installation, and operation. Neglecting fundamental installation requirements may lead to personal injury as well as damage to electrical equipment or other property.
- Before performing visual inspections, tests, or maintenance on this equipment, disconnect all sources of electric power. Assume that all circuits are live until they have been completely de-energized, tested, grounded, and tagged. Pay particular attention to the design of the power system. Consider all sources of power, including the possibility of backfeeding.

Failure to observe this precaution will result in equipment damage, severe personal injury, or death!

USING THIS MANUAL

This document provides the information required to install and operate the Circuit Monitor. The document consists of a table of contents, twelve chapters, and a number of appendices. Chapters longer than a few pages begin with a chapter table of contents. To locate information on a specific topic, refer to the table of contents at the beginning of the document, or the table of contents at the beginning of a specific chapter.

Topics Not Covered Here

Some of the Circuit Monitor's advanced features, such as on-board data log and event log files, must be set up over the communications link using POWERLOGIC application software. This Circuit Monitor instruction bulletin describes these advanced features, but does not tell how to set them up. For instructions on setting up these advanced features, refer to the application software instruction bulletin.

Notational Conventions

This document uses the following notational conventions:

- **Procedures.** Each procedure begins with an italicized statement of the task, followed by a numbered list of steps. Procedures require you to take action.
- **Bullets.** Bulleted lists, such as this one, provide information but not procedural steps. They do not require you to take action.
- **Cross-References.** Cross-references to other sections in the document appear in boldface. Example: see **Mounting the Circuit Monitor** in **Chapter 3**.

CHAPTER 2—HARDWARE DESCRIPTION

FRONT PANEL

The Circuit Monitor front panel is designed for maximum ease of use. The Circuit Monitor has five modes of operation:

- METERS — for viewing real-time metered data
- MIN — for viewing the minimum of the selected metered value
- MAX — for viewing the maximum of the selected metered value
- ALARM — for viewing the status of on-board alarms
- [Setup] — for setting up the Circuit Monitor

The general procedure for displaying data is simple:

1. Press the MODE button to select one of the five available modes.
2. Press the SELECT METER buttons to select a metered value.
3. Press the PHASE button to select a phase.

In [Setup] mode, use the alternate descriptions in grey to the right of the LEDs. In SETUP mode, the PHASE, MODE, and SELECT METER buttons function differently than in the other display modes. For details see **Chapter 4—Front Panel Operation**.

Figure 2-1 shows the front panel of the Circuit Monitor. A description of the front panel follows.

- ① **6-Digit LED display.** For local display of metered values.
- ② **Kilo/Mega LEDs.** The Kilo LED lights when the displayed value is in Kilo units. The Mega LED lights when the displayed value is in Mega units.
- ③ **Meter Indication LEDs.** The lit LED indicates the value being displayed.
- ④ **Setup/Reset Parameters.** These grey, bracketed values are used to set up the Circuit Monitor and perform resets. Refer to these values when in [Setup] mode.
- ⑤ **Phase Indication LEDs.** Indicate the phase for the displayed value.
Note: If you select a metered value that does not provide a reading for the selected phase, the Circuit Monitor automatically jumps to a phase for which a reading exists. For example, assume that you are viewing Phase A Power Factor, then change to Frequency; the Circuit Monitor automatically jumps from Phase A to 3-Phase, since the Circuit Monitor does not provide a Phase A Frequency reading.
- ⑥ **PHASE Select Button.** Press to select the phase for the selected meter value. **Note:** In [Setup] mode, press this button to move from one setup parameter to the next. See **Chapter 4—Front Panel Operation** for details.
- ⑦ **SELECT METER buttons.** Press to change the metered value being displayed. **Note:** In [Setup] mode, press these buttons to change the value of the displayed setup parameter. See **Chapter 4—Front Panel Operation** for details.

- ⑥ **Mode Indication LEDs.** These LEDs indicate the present display mode. The Alarm LED flashes when an alarm is active.
- ⑨ **MODE Select Button.** Press to select the display mode.
- ⑩ **Optical Communications Port.** This port allows the Circuit Monitor to communicate to a portable computer using the optical communications interface (Class 3090 Type OCI-2000). The OCI-2000 mounts magnetically to the Circuit Monitor and provides a standard RS-232 interface. Anything that can be done over the RS-485 communications link—including Circuit Monitor setup—can also be done using the optical communications port. Appendix J tells how to use the OCI-2000.

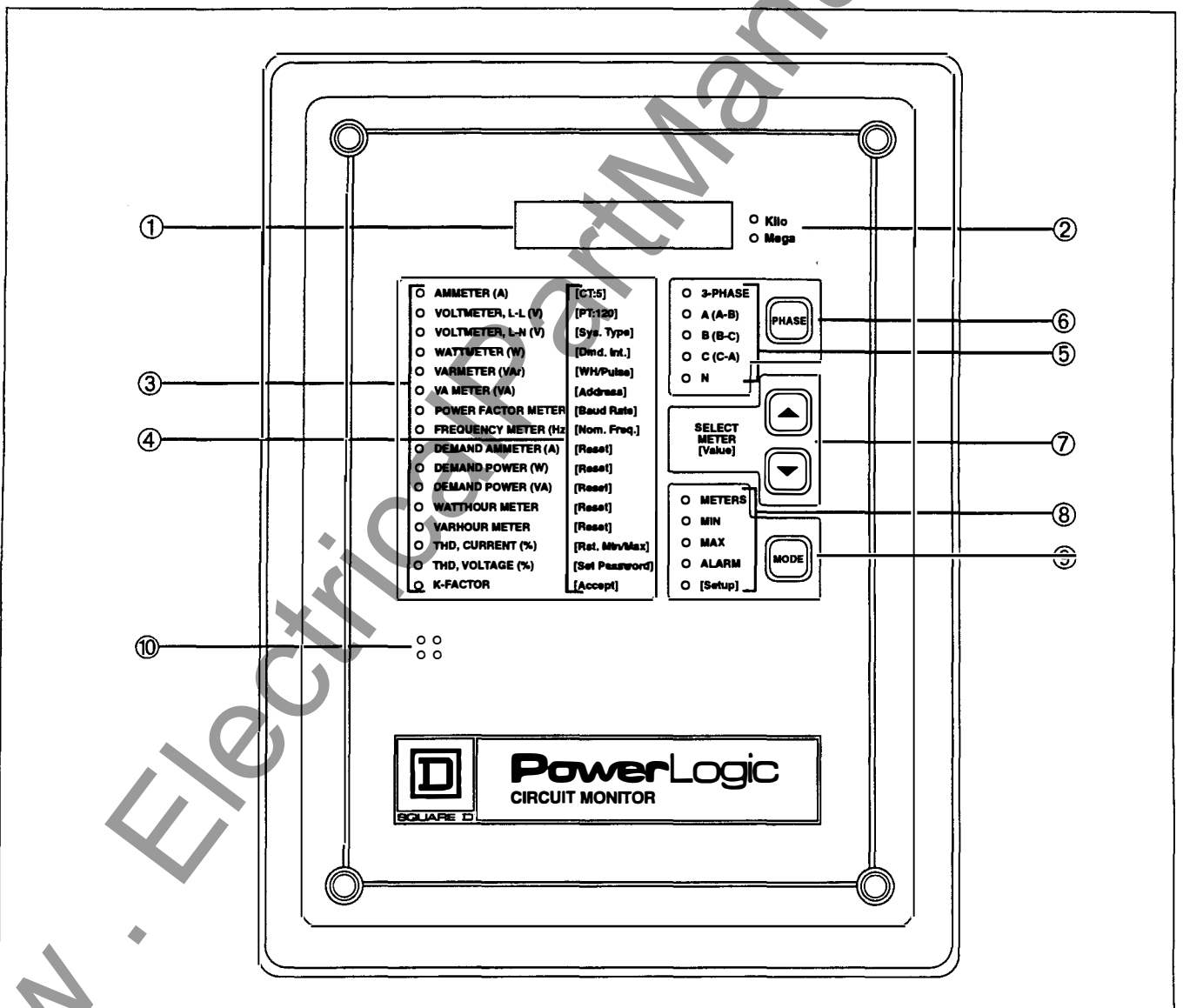

Figure 2-1: Circuit Monitor front panel

REAR CONNECTIONS

Figure 2-2 shows the rear of the Circuit Monitor. A description of each item follows.

Note: See Chapter 3—Installation for wiring instructions.

- ① Auxiliary Current Inputs
- ② 3-Phase Current Inputs
- ③ 3-Phase Voltage Inputs
- ④ RS-485 Communications Terminals
- ⑤ Input/Output Module Connector
- ⑥ Control Power Terminals

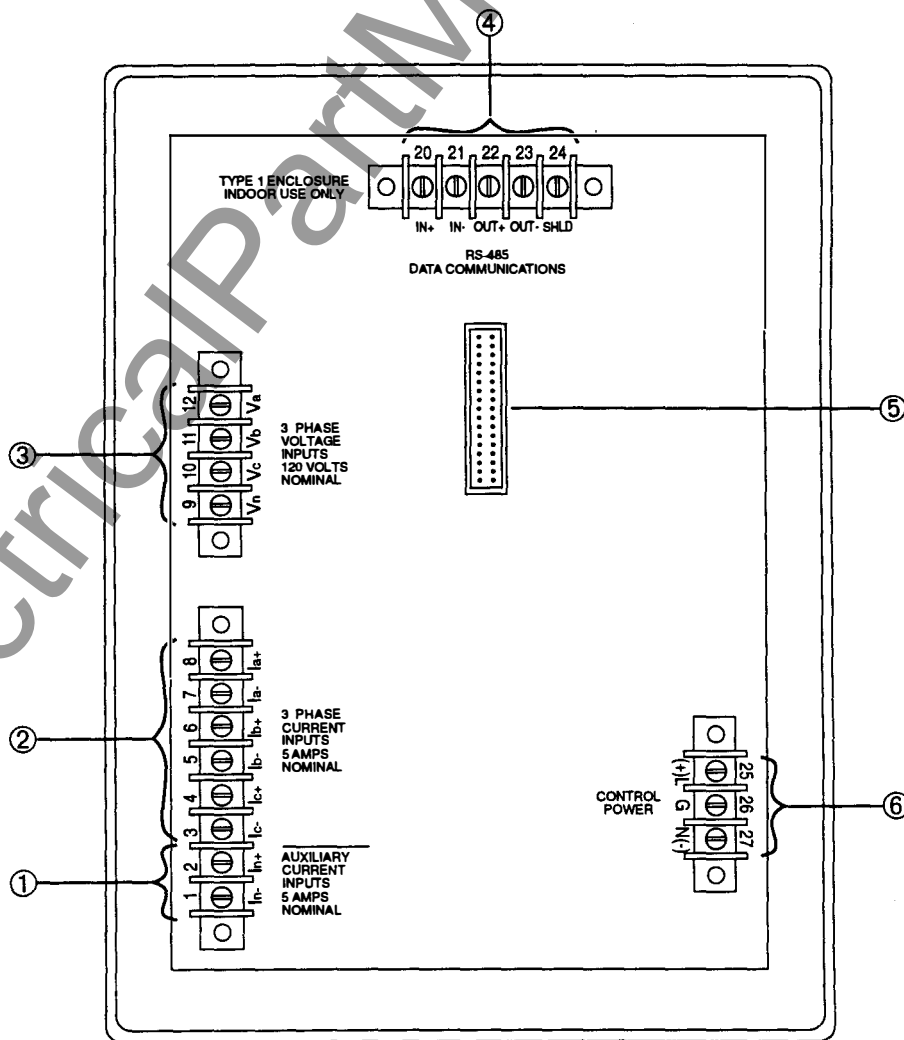

Figure 2-2: Back of the Circuit Monitor

CHAPTER 3—INSTALLATION**CHAPTER CONTENTS**

This chapter tells how to mount and wire the Circuit Monitor. Refer to the table of contents below to locate a specific topic.

Mounting the Circuit Monitor	10
Wiring CTs, PTs, and Control Power	12
Wiring Multiple Circuit Monitors to a Single Set of PTs/CPT	17
Deriving Control Power from Phase PT inputs	18
Grounding the Circuit Monitor	19
Communications Wiring	20
Connecting to a System Display	21
Connecting to a Personal Computer	22
Connecting to a POWERLOGIC Network Interface Module	23
Connecting to a SY/MAX Programmable Controller	24
Length of the Communications Link	25
Daisy-Chaining POWERLOGIC Devices	26
Terminating the Communications Link	27
Biasing the Communications Link	28

DANGER
HAZARD OF PERSONAL INJURY OR DEATH.

Only qualified electrical workers should install and wire this equipment. Such work should be performed only after reading this complete set of instructions.

Failure to observe this precaution will result in severe personal injury or death!

MOUNTING THE CIRCUIT MONITOR

The Circuit Monitor is a flush-mounted device that projects through the back of a panel or breaker cell door. Table 3-1 lists typical mounting locations in various power equipment designs.

Note: Series 2000 Circuit Monitors use the same cutout dimensions and hole patterns as the Series 100, 200 Circuit Monitors, but the required rear clearances have increased.

When choosing a mounting location, consider the following points:

- Allow for easy access to the rear of the Circuit Monitor.
- Allow extra space for all wires, shorting blocks, or other components.
- Consider the depth of the Circuit Monitor. Include extra depth for add-on modules that you might add in the future. See Appendix A for Circuit Monitor dimensions.
- Be sure that ambient conditions fall within the acceptable range: operating temperature -25 to +70° C, relative humidity, 5-95% non-condensing.

NOTE

Before preparing the cutout, refer to **Appendix A** and verify that the required clearances exist.

To mount the Circuit Monitor, complete the following steps:

1. Prepare the cutout and mounting holes. Refer to Figure 3-1 for exact dimensions.
2. Insert the Circuit Monitor through the cutout from the front of the panel or breaker cell door. Guide the Circuit Monitor mounting studs through the holes in the panel.
3. Secure the Circuit Monitor to the panel using four #10-32 hex nuts included in the Circuit Monitor hardware kit (63230-204-16). Figure 3-2 shows the Circuit Monitor mounted in an electrical panel.

Table 3-1
Typical Circuit Monitor Mounting Locations

Equipment Type	Mounting Location
QED Switchboards, Model 6 MCCs	Main Meter Location or Aux. Section
Power Zone III Switchgear	Main Instrument Compartment Door
HVL and Visi/Vac Switchgear	9-inch Front Panel or Instrument Door
Metal-Clad and Substation CBs	Standard Relaying Locations
Isoflex Medium Voltage MCCs	Standard Relaying Locations

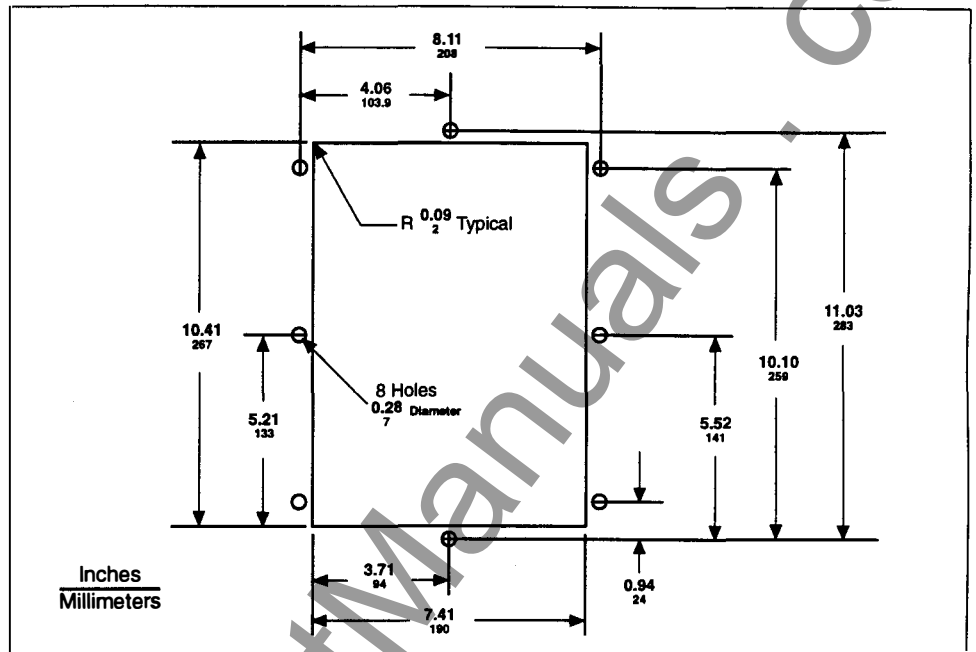

Figure 3-1: Panel preparation

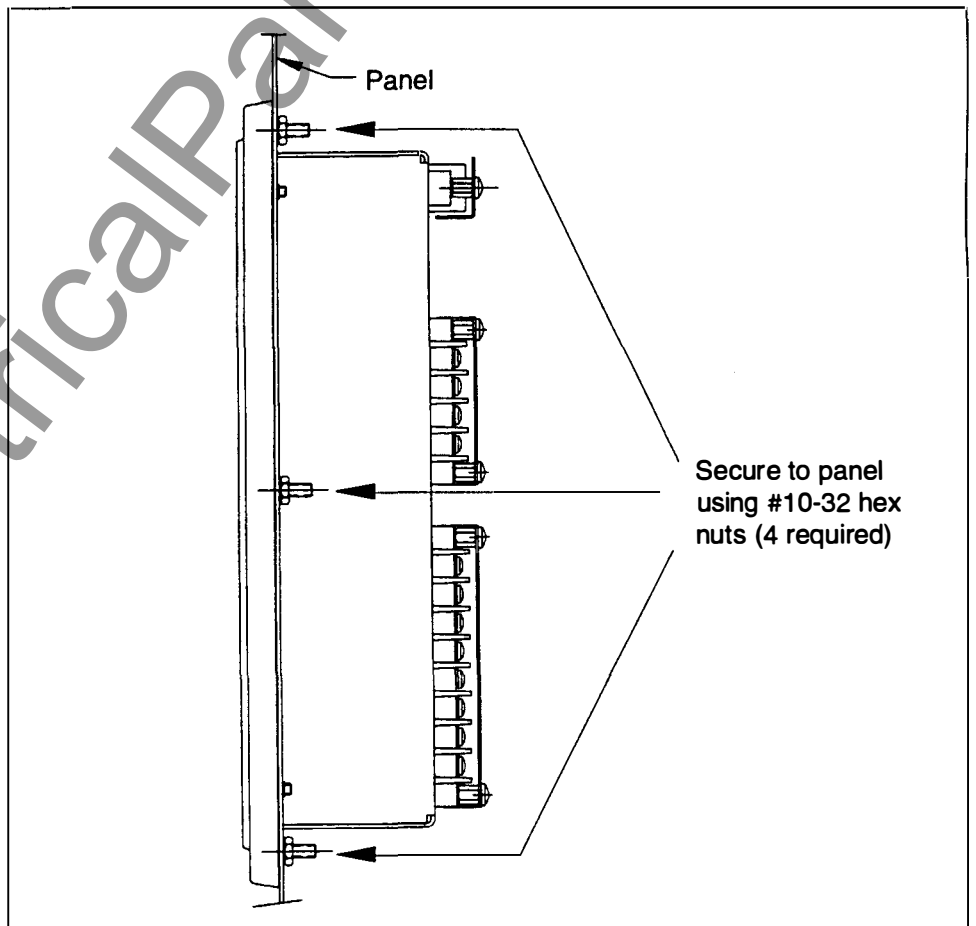

Figure 3-2: Circuit Monitor mounted in electrical panel

WIRING CTS, PTS, AND CONTROL POWER

The Circuit Monitor supports a variety of 3-phase power system wiring connections, including 3-wire delta, and 4-wire wye. Table 3-2 lists the supported system connections. Figures 3-3 through 3-5 show CT, PT, and control power wiring. Figure 3-6 on page 16 shows dc control power.

NOTE

- When wiring the Circuit Monitor, route wires *outward* to make room for add-on modules that you might install in the future.
- Wiring instructions are also included in CM hardware kit.

To wire the Circuit Monitor, complete the following steps:

1. Using a Thomas and Betts crimping tool, catalog no. Wt1455 or equivalent, crimp the blue spade connectors included with the Circuit Monitor onto the wires for the voltage, current, and control power inputs.
2. Connect the spade connectors to the Circuit Monitor terminals as shown in the appropriate wiring diagram. (Figures 3-3 through 3-5 show wiring connections.) Do not overtighten screws, but ensure that they are snug.
3. Ground the Circuit Monitor. See **Grounding the Circuit Monitor** in this chapter for instructions.
4. Install protective terminal strip covers. See **Appendix H** for instructions.

⚠ DANGER

HAZARD OF PERSONAL INJURY OR DEATH.

Only qualified electrical workers should install and wire this equipment. Such work should be performed only after reading this complete set of instructions. Follow proper safety procedures regarding CT secondary wiring. Never open circuit the secondary of a CT.

Failure to observe this precaution will result in severe personal injury or death!

**Table 3-2
 Supported System Wiring Connections**

System Type	Sys ID ^①	# CTS	Aux. CT	# PTs	PT Conn.	Currents	Voltages	Figure #
3∅, 3-wire Delta	30	2	None	2	Open Delta	A, B ^② , C	A-B, B-C, C-A ^②	3-3
3∅, 4-wire Wye, Ground	40	3	None	3	Wye-Wye	A, B, C, N ^②	A-N, B-N, C-N A-B ^② , B-C ^② , C-A ^②	3-4
3∅, 4-wire Wye, Ground	41	3	Neut	3	Wye-Wye	A, B, C, N, G ^②	A-N, B-N, C-N A-B ^② , B-C ^② , C-A ^②	3-5

① The System ID is used during setup to specify the system type.
 ② Indicates a value that is calculated rather than measured directly.

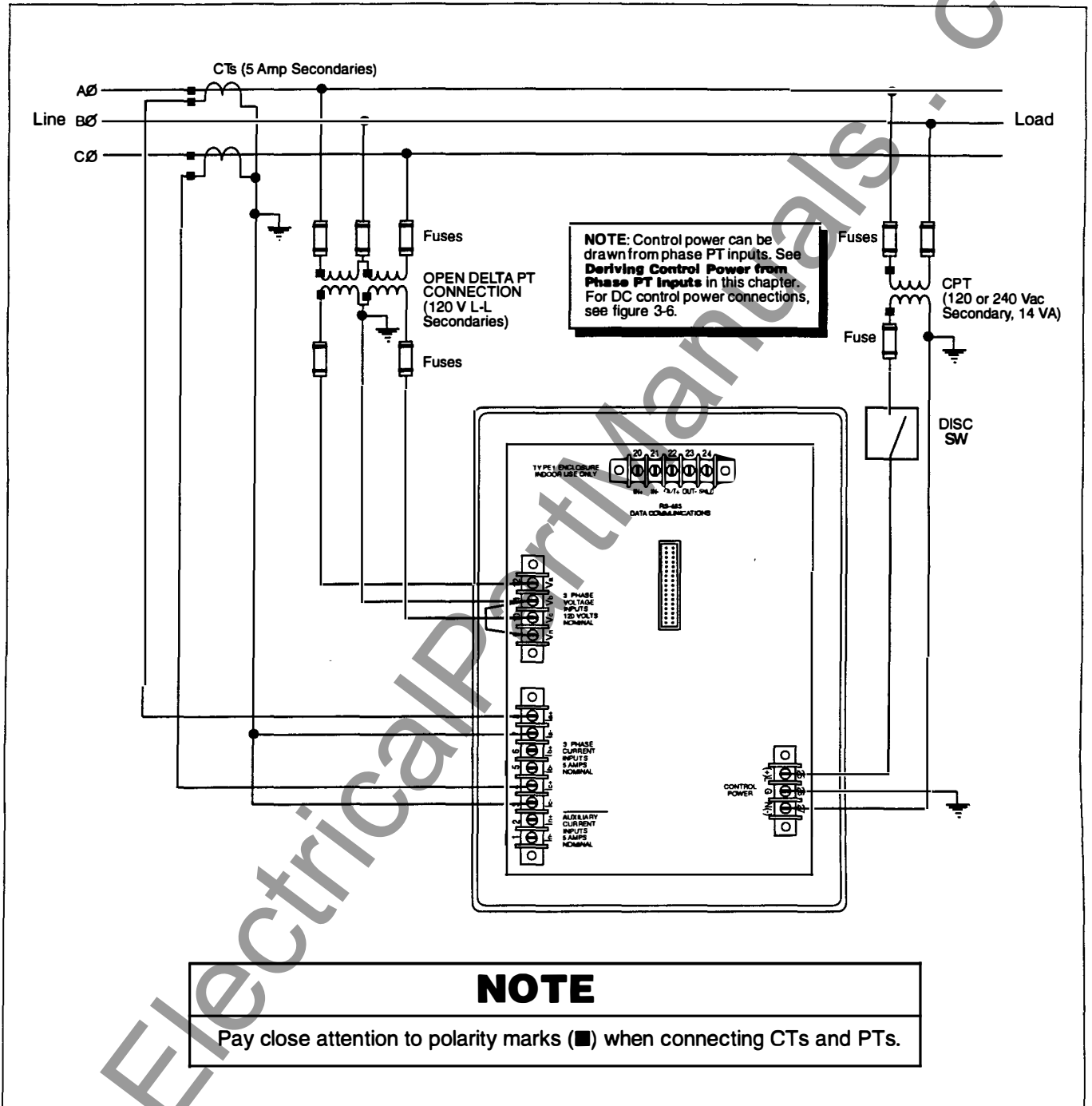

Figure 3-3: 3-phase 3-wire delta connection

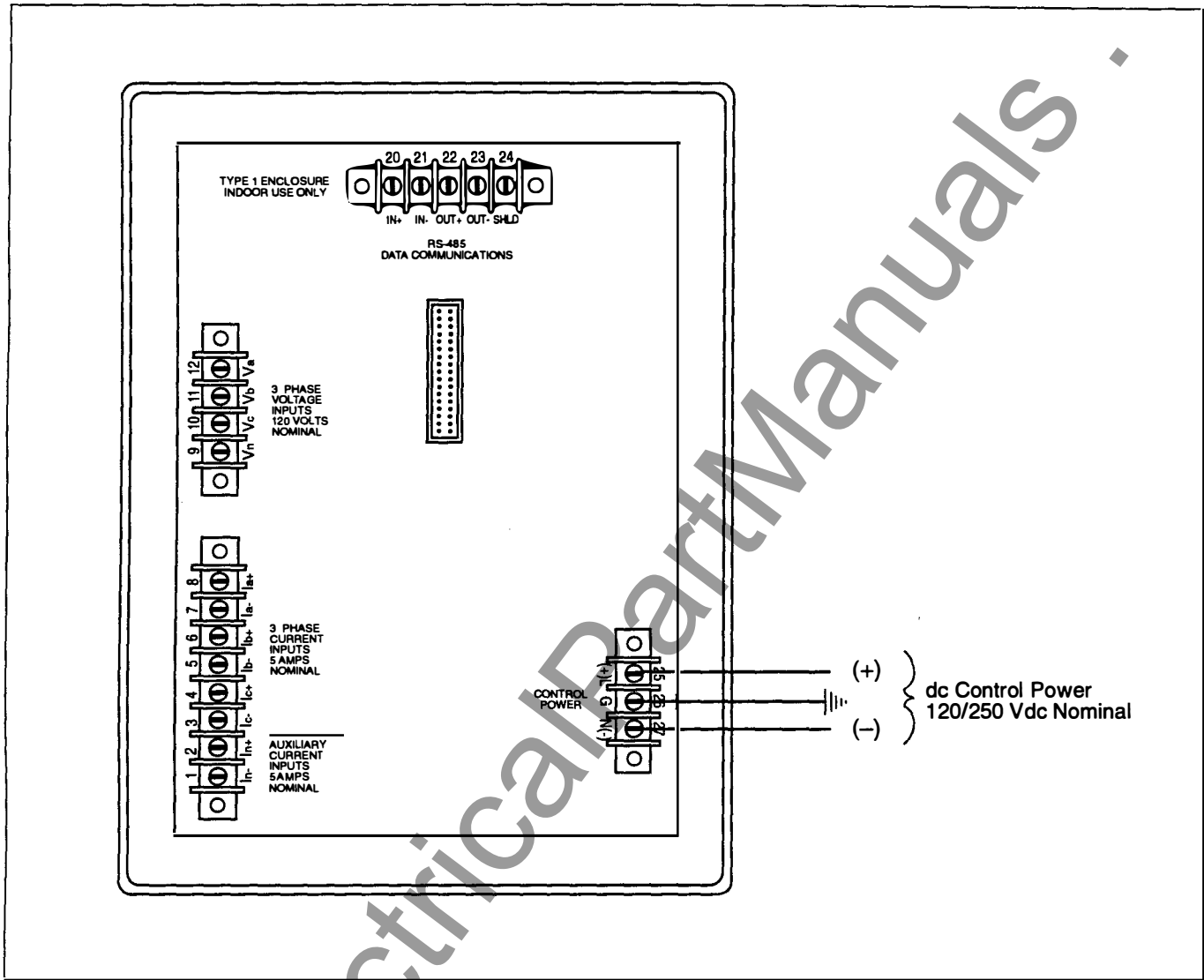

Figure 3-6: DC control power connections

Wiring Multiple Circuit Monitors to a Single Set of PTs/CPT

Multiple Circuit Monitors can share one set of 3-phase PTs. Also, multiple Circuit Monitors can share a single control power transformer (CPT). In all cases, each Circuit Monitor must use a separate set of CTs. Figure 3-7 shows how to connect multiple Circuit Monitors to a single set of PTs and CPT.

NOTE

When using this wiring method, ground the PT secondaries in only one location.

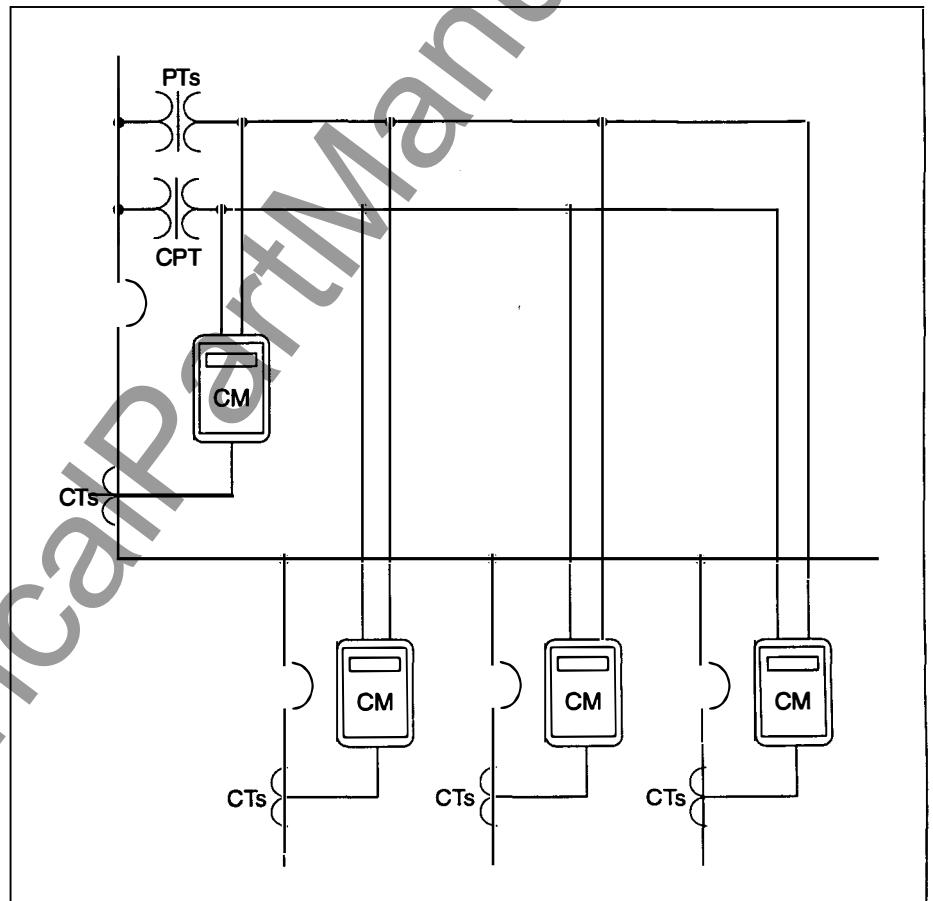



Figure 3-7: Circuit Monitors connected to one set of PTs and one CPT

Deriving Control Power from Phase PT Inputs

Whenever possible, derive Circuit Monitor control power from a stable voltage source. If such a source is unavailable, the Circuit Monitor can derive control power from its phase PT inputs. The procedure below tells how to do this. Figure 3-8 shows the proper connections.

To derive control power from phase PT inputs, complete the following steps:

1. Connect the Va terminal (terminal 12) to the L terminal (terminal 25).
2. Connect the Vn terminal (terminal 9) to the N terminal (terminal 27).
3. Install protective terminal strip covers. See Appendix H for instructions.

 **CAUTION**

HAZARD OF EQUIPMENT DAMAGE.

When deriving control power from the phase PT inputs, the phase PT used must have a VA rating sufficient for all connected burdens.

If the VA rating is exceeded, it could reduce the voltage transformer's accuracy or damage the PT.

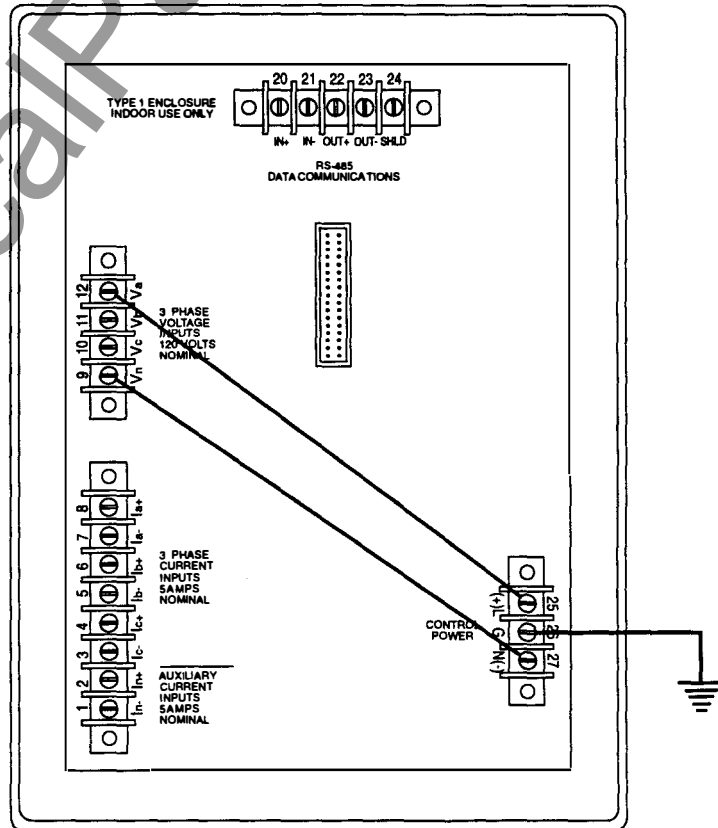

Figure 3-8: Deriving control power from phase PT inputs

GROUNDING THE CIRCUIT MONITOR

For optimal grounding, connect the Circuit Monitor to a true earth ground.

To ground the Circuit Monitor, complete the following steps:

1. Connect the Ground terminal (terminal 26) to a true earth ground, using #14 AWG wire or larger with spade connector (see figure 3-9).
2. Install protective terminal strip cover. See Appendix H for instructions.

⚠ DANGER

HAZARD OF ELECTRIC SHOCK.

Ground the Circuit Monitor as described in these instructions. Failure to properly ground the Circuit Monitor may allow hazardous voltages to be present on the Circuit Monitor chassis.

Failure to observe this precaution will result in severe personal injury or death!

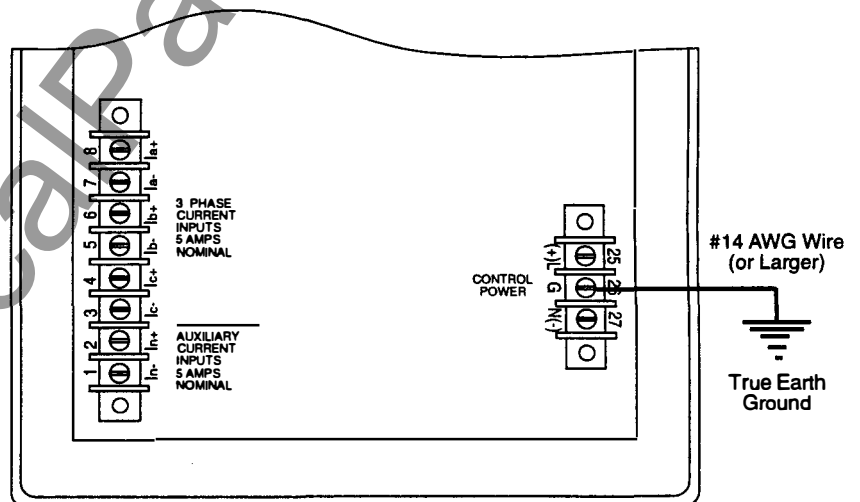

Figure 3-9: Grounding the Circuit Monitor

COMMUNICATIONS WIRING

POWERLOGIC devices are equipped with RS-485 communications. The RS-485 standard lets you daisy-chain up to 32 POWERLOGIC-compatible devices to a single communications port. This document refers to a chain of POWERLOGIC devices connected by communications cable as a *communications link*.

A POWERLOGIC communications link can consist of up to 32 POWERLOGIC-compatible devices connected to a communications port on one of the following:

- POWERLOGIC System Display
- Personal computer
- POWERLOGIC Network Interface Module
- SY/MAX programmable controller
- Other host devices with a POWERLOGIC-compatible port

Figures 3-10 through 3-13 show Circuit Monitors and other POWERLOGIC compatible devices connected in typical systems. The accompanying text describes important considerations for each connection alternative.

The figures also show the placement of communications adapters and terminators. For additional information on using the communications adapter and terminator, see **Terminating the Communications Link**, and **Biasing the Communications Link** in this chapter.

Connecting to a System Display

- Connect up to 32 Circuit Monitors to the System Display for Circuit Monitors (Class 3050 Types SD-200, SD-220). See **Length of the Communications Link** in this chapter for distance limitations at varying baud rates.
- Connect Circuit Monitors to the RS-485 port on the bottom of the System Display.
- Configure the System Display's baud rate to match the baud rate of Circuit Monitors on the communications link.
- Refer to the instruction bulletin for the System Display for Circuit Monitors (Class 3050 Types SD-200, SD-220) for detailed instructions on configuring the System Display.

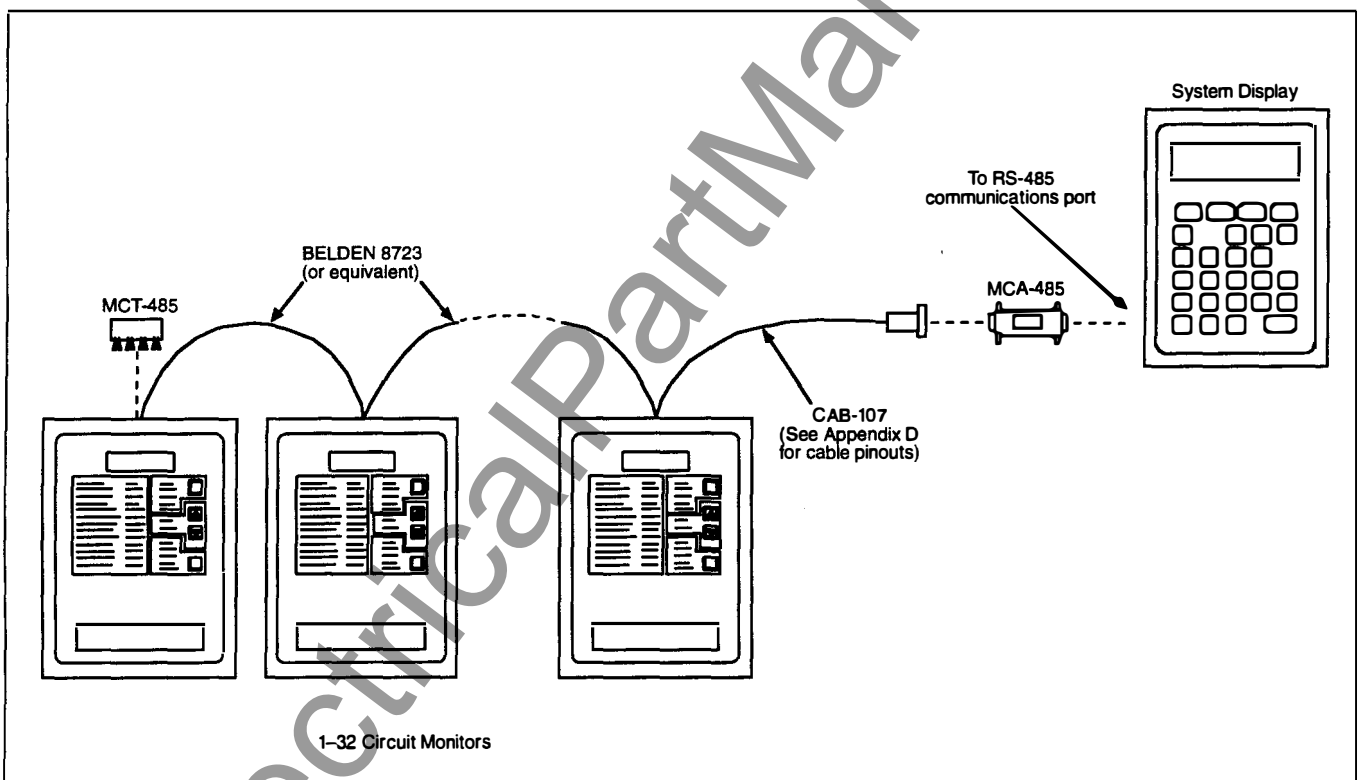

Figure 3-10: Circuit Monitors connected to a System Display for Circuit Monitors

Connecting to a Personal Computer

- Connect up to 32 POWERLOGIC devices to a personal computer. See **Length of the Communications Link** in this chapter for distance limitations at varying baud rates.
- POWERLOGIC devices can be connected to a SY/LINK card installed in the personal computer. To do this, connect the POWERLOGIC devices to the RS-422 port (top port) of the SY/LINK card.
- POWERLOGIC devices can be connected to a serial COMM port on the personal computer. To do this, two things are required:
 1. The POWERLOGIC devices must be connected to an RS-232 to RS-422/RS-485 converter which is connected to the personal computer. POWERLOGIC offers a converter kit for this purpose (Class 3090 Type MCI-101). Refer to the instruction bulletin included with the MCI-101 for connection instructions.
 2. The computer must be equipped with POWERLOGIC Product Communications software (3080 PSW-101). PSW-101 supports serial COMM port communications.

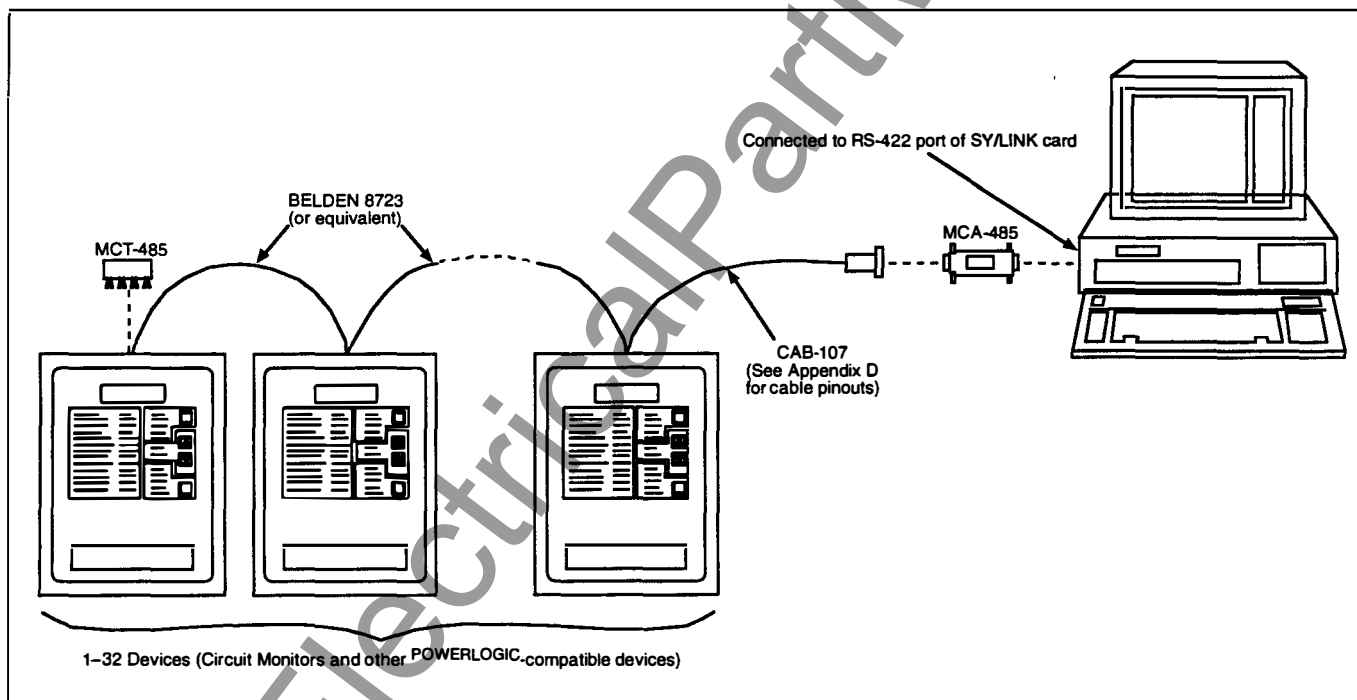

Figure 3-11: POWERLOGIC devices connected directly to a personal computer.

Connecting to a POWERLOGIC Network Interface Module (PNIM)

- Connect up to 32 POWERLOGIC devices to a PNIM. See **Length of the Communications Link** in this chapter for distance limitations at different baud rates.
- Connect POWERLOGIC devices to PNIM port 0 (top RS-485 port) only.
- Configure PNIM port 0 for "POWERLOGIC" mode. (See side of PNIM for instructions on setting dip switches.)
- Configure the baud rate of PNIM port 0 to match the baud rate of the POWERLOGIC devices on the communications link.
- Refer to the PNIM instruction bulletin for detailed instructions on configuring the PNIM.

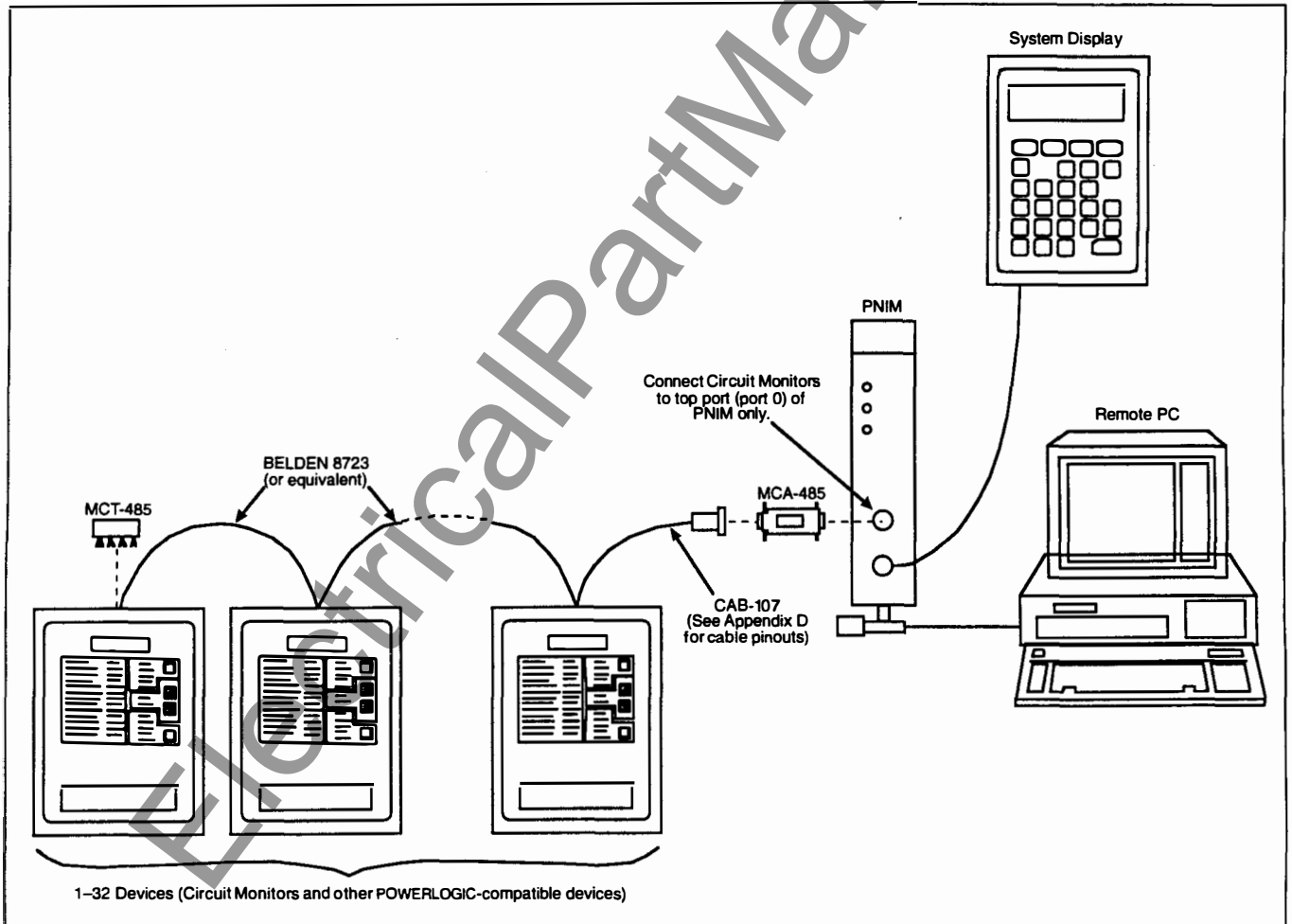

Figure 3-12: POWERLOGIC devices connected to a PNIM.

Connecting to a SY/MAX Programmable Controller

- Connect up to 32 POWERLOGIC devices to a programmable controller. See **Length of the Communications Link** in this chapter for distance limitations at different baud rates.
- Connect POWERLOGIC devices to the RS-422 port of the programmable controller.
- The programmable controller must contain a program to access POWERLOGIC device data.
- Configure the baud rate of the programmable controller's port to match the baud rate of the POWERLOGIC devices on the communications link.
- Refer to the programmable controller instruction manual for detailed instructions on configuring the programmable controller.

NOTE

POWERLOGIC devices can be connected to other manufacturer's systems using available communication interfaces. For further information, contact the POWERLOGIC Technical Support Center. See **Getting Technical Support** in Chapter 6.

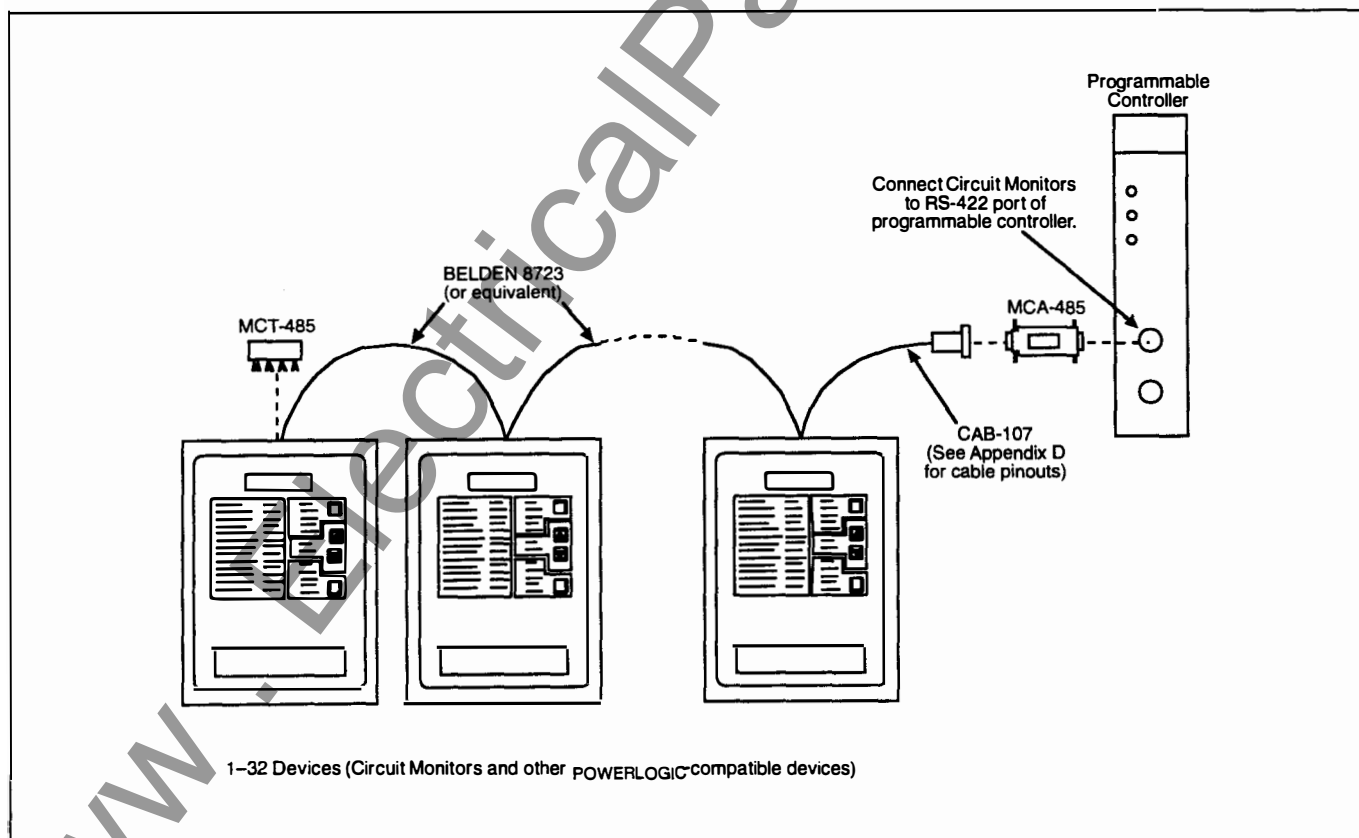

Figure 3-13: POWERLOGIC devices connected to a SY/MAX programmable controller.

Length of the Communications Link

The length of the communications link cannot exceed 10,000 feet (3,050 m). This means that the total length of the communications cable from the PNM, personal computer, System Display, or processor, to the last device in the daisy-chain, cannot exceed 10,000 feet. When 17 or more devices are on a communications link, the maximum distance may be shorter, depending on the baud rate. Table 3-3 shows the maximum distances at different baud rates.

Table 3-3
Maximum Distances of Comms Link at Different Baud Rates

Baud Rate	Maximum Distances	
	1-16 devices	17-32 devices
1200	10,000 ft. (3,050 m)	10,000 ft. (3,050 m)
2400	10,000 ft. (3,050 m)	5,000 ft. (1,525 m)
4800	10,000 ft. (3,050 m)	5,000 ft. (1,525 m)
9600	10,000 ft. (3,050 m)	4,000 ft. (1,220 m)
19200	10,000 ft. (3,050 m)	2,500 ft. (762.5 m)

**Daisy-Chaining
POWERLOGIC Devices**

NOTE

To daisy-chain POWERLOGIC devices, use communications cable containing two twisted-shielded pairs (Belden 8723 or equivalent). Connect the wires to the Circuit Monitor's terminals using the red spade connectors included with the Circuit Monitor. Crimp the red connectors onto the communications wires using a Thomas and Betts crimping tool, catalog no. Wt1455, or equivalent.

Each communicating POWERLOGIC device has five RS-485 terminals for connection to a POWERLOGIC communications link. On all devices, the terminals are labeled IN+, IN-, OUT+, OUT-, and SHLD. On the Circuit Monitor, the IN+, IN-, OUT+, OUT-, and SHLD terminals are numbered 20, 21, 22, 23, and 24, respectively.

To daisy-chain the Circuit Monitor to another POWERLOGIC device, wire the Circuit Monitor's RS-485 communications terminals to the matching communications terminals of the next device. In other words, wire the IN+ terminal of the Circuit Monitor to the IN+ terminal of the next device, wire IN- to IN-, OUT+ to OUT+, OUT- to OUT-, and SHLD to SHLD. See Figure 3-14.

If the Circuit Monitor is the last device on the daisy-chain, terminate it. See **Terminating the Communications Link** in this chapter for instructions. If the Circuit Monitor is the first device on the daisy-chain, connect it to the PNIM, personal computer, System Display, or programmable controller using a CAB-107 or equivalent cable and a Multipoint Communications Adapter. See **Biasing the Communications Link** in this chapter for instructions. See Appendix D for the CAB-107 pinout.

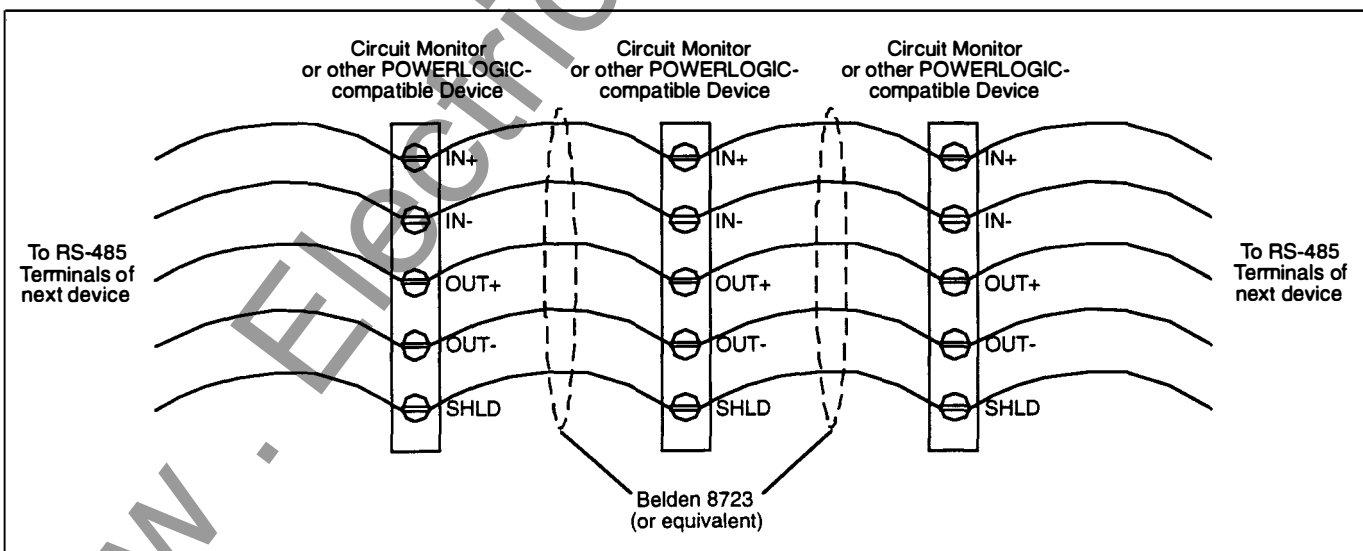

Figure 3-14: Daisy-chaining the RS-485 communications terminals

Terminating the Communications Link

To ensure reliable communications, terminate the last device on a POWERLOGIC communications link. To terminate the last device, use a POWERLOGIC Multipoint Communications Terminator (Class 3090 Type MCT-485).

To terminate a Circuit Monitor, slide the terminator's four spade connectors under the IN+, IN-, OUT+, and OUT- terminals on the back of the Circuit Monitor and tighten. Figure 3-15 shows proper placement of the terminator. Figures 3-10 to 3-13 show the terminator applied in typical systems.

NOTE

Terminate only the last device on the link. If a link has only one device, terminate that device.

NOTE

Some POWERLOGIC devices use a removable communications connector. If the last device on the communications link is not a Circuit Monitor, refer to the instruction bulletin for that device for termination instructions.

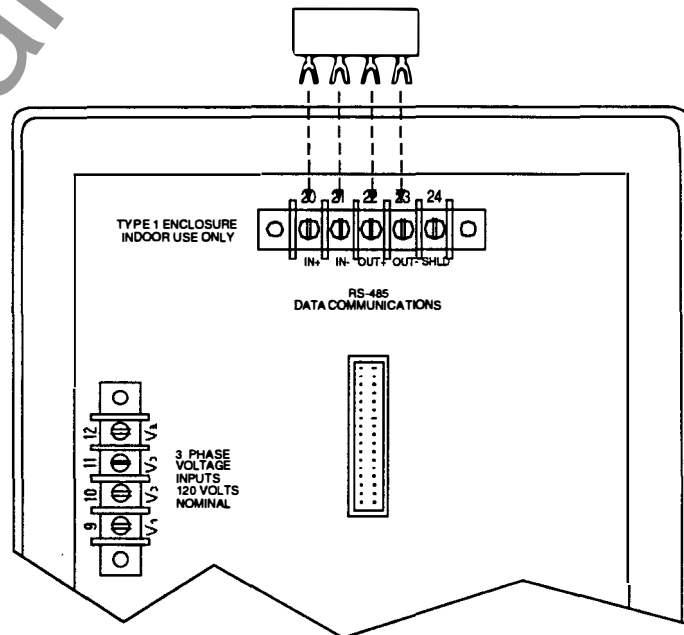

Figure 3-15: Terminator placement when last device on the link is a Circuit Monitor

Biasing the Communications Link

To ensure reliable communications, bias the communications link. To bias the communications link, use a POWERLOGIC Multipoint Communications Adapter (Class 3090 Type MCA-485).

To bias the communications link, plug the adapter into the communications port of the device to which one or more POWERLOGIC devices are connected. Plug the CAB-107 cable connected to the first POWERLOGIC device on the link into the other end of the adapter.

Figure 3-16 shows the adapter connected to a POWERLOGIC Network Interface Module (PNIM). Figures 3-10 to 3-13 show the adapter applied in typical systems.

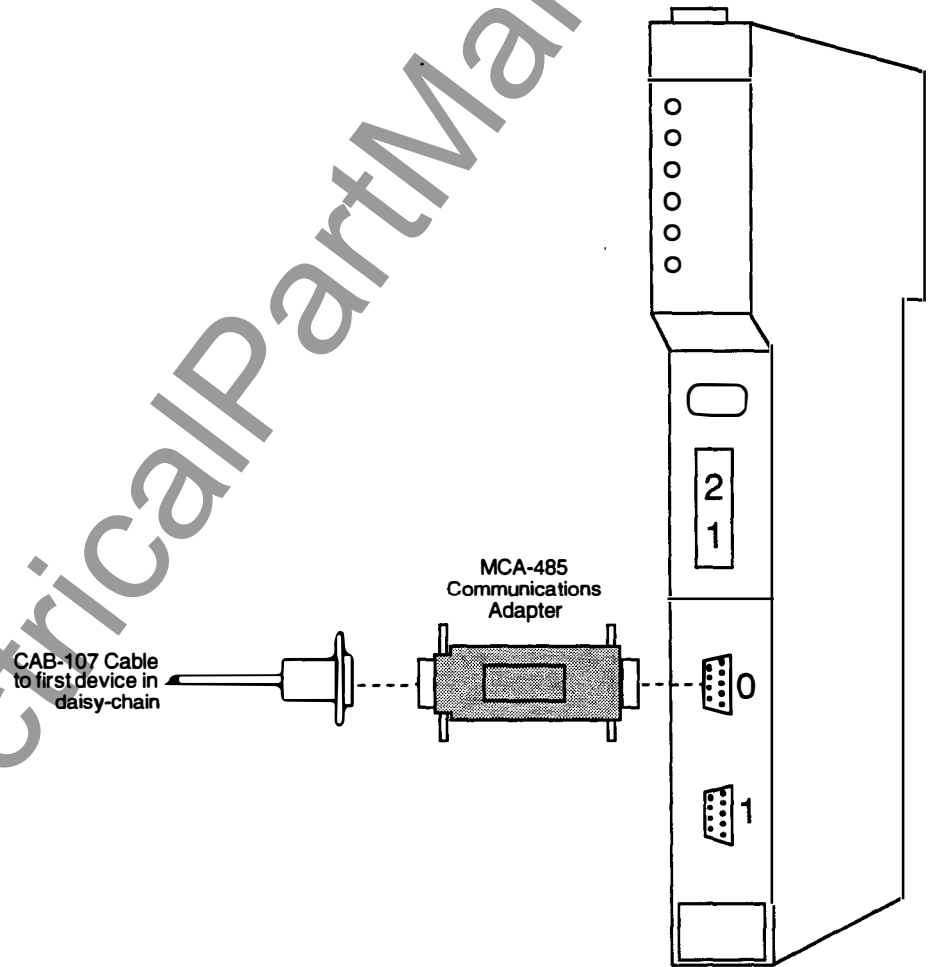

Figure 3-16: Multipoint Communications Adapter connected to PNIM

CHAPTER 4—FRONT PANEL OPERATION

CHAPTER CONTENTS

This chapter tells how to set up the Circuit Monitor from the front panel only. Some advanced Circuit Monitor features, such as event log/data log configuration, must be set up over the communications link. You can set up these advanced features using POWERLOGIC software. Refer to the software instruction bulletin for instructions on setting up advanced features.

The Setup Mode	30
The Configuration Option	30
The Resets Option	30
The Alarm/Relay Option	30
The Diagnostics Option	30
Choosing a Setup Option	31
How the Buttons Work	31
Configuring the Circuit Monitor	32
Factory Defaults	32
General Configuration Procedure	32
Viewing Configuration Data in Protected Mode	35
Setting the Master Password	36
Setting the CT Ratios	37
Setting the PT Ratio	38
Setting the System Type	39
Setting the Demand Interval	39
Setting the Watthour/Pulse Output	41
Setting the Device Address	42
Setting the Baud Rate	43
Setting the Nominal Frequency	44
Resetting Demand, Energy, and Min/Max Values	45
Performing Resets Using The Resets Option	46
Setting Up Alarm/Relay Functions	47
General Setup Procedure	48
Detailed Setup Procedure	49
Viewing Active Alarms	52
Viewing the Priority 1 Log	53
Clearing the Priority 1 Log	54

THE SETUP MODE

To access the Setup Mode, press the MODE button until the red led next to [Setup] is lit. The Circuit Monitor displays "Config"—the first of four setup options. The Circuit Monitor displays the options as abbreviated combinations of uppercase and lowercase letters. The abbreviations displayed by the Circuit Monitor, and their full names are shown below.

<u>Full Name</u>	<u>CM Display</u>
Configuration Option	ConFig
Resets Option	rESETs
Alarm/Relay Option	AL.rLy
Diagnostics Option	diAG

The Configuration Option

The Configuration option lets you configure the following values: CT and PT primaries, system type, demand interval, WH/pulse output, device address, baud rate, nominal frequency, and password. You can also reset energy, demand, and min/max values. See **Configuring the Circuit Monitor**, on the following page, for more information.

The Resets Option

The Resets option lets you reset energy, demand and min/max values. These same reset operations can be done using the Configuration option. The difference is that using the Resets option, you cannot change Circuit Monitor configuration values. See **Performing Resets Using the Resets Option**, in this chapter for more information.

The Alarm/Relay Option

The Alarm/Relay option lets you configure the Circuit Monitor's on-board alarm/relay functions. (See Appendix I for a complete listing of the Circuit Monitor's predefined alarm conditions.) For each of the Circuit Monitor's predefined alarm conditions, you can:

- Enable or disable it
- Assign a priority to it
- Define any required pickup and dropout setpoints, and pickup and dropout time delays
- Setup the Circuit Monitor to operate up to three relay outputs when the alarm condition occurs

See **Setting Up Alarm/Relay Functions**, on page 47, for details on how to use this option.

The Diagnostics Option

The Diagnostics option lets you read and write Circuit Monitor registers. Use this feature with caution. Writing an incorrect value, could cause the Circuit Monitor to operate incorrectly. See **Appendix L** for instructions on reading and writing registers using the Diagnostics option.

Choosing a Setup Option

To enter the [Setup] mode, press the MODE button until the [Setup] LED is lit. The Circuit Monitor displays “ConFig.” To move to a specific option, use the SELECT METER [Value] buttons. To select an option, press the PHASE [Enter] button (see figure 4-1).

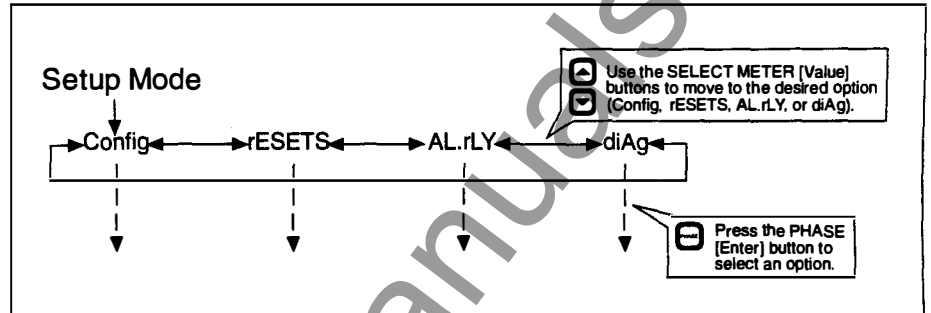

Figure 4-1: Choosing a Setup Option

How the Buttons Work

The Circuit Monitor’s front panel buttons perform different functions in Setup mode than in Meters mode. In Setup mode, the buttons work as described below.



The PHASE [Enter] button. In Setup mode, use this button as an “Enter” key to accept a new configuration value and move to the next configuration item. For example, after changing the CT Primary value, press this button to enter the new value and move to the next configuration item (PT Primary). Also, press this button to move through configuration items that don’t need to be changed, to reach a specific item.



SELECT METER [Value] buttons. In Setup mode, use these buttons to increase or decrease the displayed value. Also, use these buttons to toggle between Yes and No when required.



MODE button. Use this button to exit a setup option after making all desired changes. For example, after making all desired changes within the Configuration option, press the mode key. The Circuit Monitor then asks you to accept or reject your changes.

CONFIGURING THE CIRCUIT MONITOR

This section tells how to use the Configuration option to define the following values: CT and PT ratios, system type, demand interval, WH/pulse output, device address, baud rate, nominal frequency, and password. It also tells how to reset energy, demand and min/max values.

The section **General Configuration Procedure** describes the general steps required to configure the Circuit Monitor. The remaining sections tell how to configure specific values.

Factory Defaults

Table 4-1 lists the front panel configuration parameters, their allowed values, and their factory defaults.

Table 4-1
Factory Defaults for Front Panel Configuration Parameters

Parameter	Allowed Values	Default
CT Primary		
Primary, 3-Phase	1 to 32,767	5
Primary, Neutral	0 to 32,767	5
PT Primary		
Primary, 3-Phase	1 to 1,700,000	120
System Type	30, 40, 41	40
Demand Interval	5 to 60 min.	15
WH/Pulse output	0 to 3276.7 kWh	0
Device Address	0 to 199	1
Baud Rate	1200-19.2K	9600
Frequency (Nom.)	50, 60, 400	60
Password	0 to 9998	0

General Configuration Procedure

This section describes the general steps required to configure the Circuit Monitor from the front panel. The configuration items (and reset items) are the grey items in square brackets on the front panel of the Circuit Monitor. Refer to these items when configuring the Circuit Monitor.

The front panel configuration procedure is described below. Alternately, figure 4-2 on page 34 shows the configuration procedure, with less detail, as a flow chart.

To configure the Circuit Monitor, complete the following steps:

1. Press the MODE button until the red LED next to [Setup] is lit.
The Circuit Monitor displays "ConFig".
2. Press the PHASE [Enter] button to select the Configuration option.
The Circuit Monitor displays the password prompt "P - - - -."

3. Enter the password.

To enter the password, use the SELECT METER [Value] buttons to increase or decrease the displayed value until it reaches the password value. Then press the PHASE [Enter] button. (The Circuit Monitor's default password is 0.)

The red LED next to [CT Primary] flashes.

4. Press the PHASE [Enter] button to select a configuration item.

The red LED next to the selected configuration item flashes.

5. Press the SELECT METER [Value] buttons to increase or decrease the displayed value until the desired value is displayed.

In the case of the [Reset] items, use the SELECT METER [Value] buttons to toggle between *Yes* and *No*. See **Resetting Demand, Energy, and Min/Max Values** in this chapter for more on resets.

6. Repeat steps 4 and 5 until you've made all desired configuration changes.

7. After making all desired configuration changes, press the MODE button once.

The red LED next to [Accept] flashes. The Circuit Monitor display reads *No*, and the red LEDs next to the items that you have changed are lit. Verify that only the LEDs next to the setup items you wish to change are lit.

8. To reject the changes, press the PHASE [Enter] button once.

The Circuit Monitor returns to Meters mode.

9. To accept the changes, press the SELECT METER [Value] button to change from *No* to *Yes*. Then, press the PHASE [Enter] button.

The Circuit Monitor goes through its restart procedure. This indicates that the changes have been made.

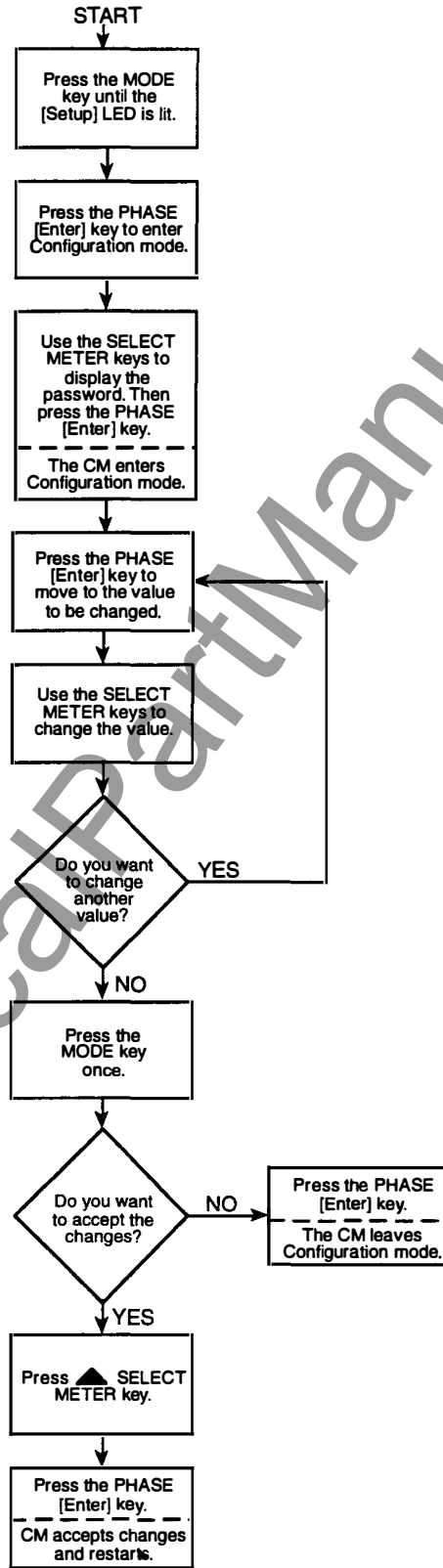

Figure 4-2: Flowchart for front panel configuration

**Viewing Configuration Data
In Protected Mode**

The Circuit Monitor provides a special protected viewing mode that lets you view, but not change, configuration data.

To view configuration data, complete the following steps:

1. Press the MODE button until the red LED next to [Setup] is lit.
The Circuit Monitor displays "ConFig".
2. Press the PHASE [Enter] button.
The Circuit Monitor displays the password prompt "P----."
3. Enter 9999 for the password.
To enter 9999, use the SELECT METER [Value] buttons to increase the displayed value until it reaches 9999. Then press the PHASE [Enter] button.
The Circuit Monitor enters the protected viewing mode.
4. Press the PHASE [Enter] button to move from one configuration item to the next.
5. To exit the protected viewing mode, press the MODE button.
The Circuit Monitor returns to METERS mode.

Setting the Master Password

The Circuit Monitor's four setup modes are password protected. A *master password* can be used to access any of the four setup modes. In addition to the master password, the Circuit Monitor provides a *reset password*. The reset password provides access to the Resets option only. Until you define a unique reset password, the reset password defaults to the master password. For instructions on defining and using the reset password see **Performing Resets Using the Resets Option** in this chapter.

The master password can be any value in the range 0 to 9998. The factory default is 0.

To change the master password, complete the following steps:

1. Press the MODE button until the red LED next to [Setup] is lit.
The Circuit Monitor displays "ConFig."
2. Press the PHASE [Enter] button to select the Configuration option.
The Circuit Monitor displays the password prompt "P ----."
3. Enter the existing master password.
To enter the password, use the SELECT METER [Value] buttons to increase or decrease the displayed value until it reaches the password value. Then press the PHASE [Enter] button. (The Circuit Monitor's default password is 0.)
4. Press the PHASE [Enter] button until the red LED next to [Set Password] flashes.
5. Press the SELECT METER [Value] buttons until the desired password value is displayed.
The password can be any value from 0 to 9998.
6. Press the MODE button once.
The red LED next to [Accept] flashes. The red LED next to [Set Password] glows steadily.
7. To reject the new password, press the PHASE [Enter] button once.
The Circuit Monitor returns to METERS mode.
8. To accept the new password, press the up arrow SELECT METER [Value] button to change from *No* to *Yes*. Then, press the PHASE [Enter] button.
The Circuit Monitor returns to METERS mode.

Setting the CT Ratios

The Circuit Monitor supports two primary CT ratings: one for the phase CTs and one for the neutral CT. The allowable range is 1 to 32,767. The factory default for both CT secondaries is 5.

Note: The neutral CT is optional. If the Circuit Monitor is set up for any system type that does not require a neutral CT, the Circuit Monitor ignores the neutral CT rating (even if neutral currents are reported).

To change the primary CT ratings, complete the following steps:

1. Press the MODE button until the red LED next to [Setup] is lit.
The Circuit Monitor displays "ConFig".
2. Press the PHASE [Enter] button to select the Configuration option.
The Circuit Monitor displays the password prompt "P----."
3. Enter the master password.
To enter the password, use the SELECT METER [Value] buttons to increase or decrease the displayed value until it reaches the password value. Then press the PHASE [Enter] button.
The red LED next to [CT Primary] flashes indicating that the Circuit Monitor is in Configuration mode. The 3-PHASE LED also lights indicating that the Circuit Monitor is displaying the 3-phase, primary CT rating.
4. Press the SELECT METER [Value] buttons until the desired 3-phase, primary CT rating is displayed.
5. Press the PHASE [Enter] button once.
The N (Neutral) phase LED lights, and the Circuit Monitor displays the primary CT rating for the neutral CT.
6. Press the SELECT METER [Value] buttons until the desired neutral primary CT rating is displayed.
7. Press the MODE button once.
The red LED next to [Accept] flashes. The red LED next to [CT Primary] glows steadily.
8. To reject the new CT rating(s), press the PHASE [Enter] button once.
The Circuit Monitor returns to METERS mode.
9. To accept the new CT rating(s), press the UP ARROW SELECT METER [Value] button to change from *No* to *Yes*. Then, press the PHASE [Enter] button.
The Circuit Monitor restarts.

Setting the PT Ratio

The Circuit Monitor supports one primary PT rating. The allowable range is 1 to 1,700,000 volts. The factory default PT secondary is 120V.

To change the primary PT rating, complete the following steps:

1. Press the MODE button until the red LED next to [Setup] is lit.
 The Circuit Monitor displays "ConFig".
2. Press the PHASE [Enter] button to select the Configuration option.
 The Circuit Monitor displays the password prompt "P ----."
3. Enter the master password.
 To enter the password, use the SELECT METER [Value] buttons to increase or decrease the displayed value until it reaches the password value. Then press the PHASE [Enter] button.
3. Press the PHASE [Enter] button twice.
 The red LED next to the [PT Primary] item flashes. The 3-PHASE LED lights, and the Circuit Monitor displays the primary PT rating for the 3-Phase PTs.
4. Press the SELECT METER [Value] buttons until the desired primary PT rating is displayed.
5. Press the MODE button once.
 The red LED next to [Accept] flashes. The red LED next to [PT Primary] glows steadily.
6. To reject the new PT rating, press the PHASE [Enter] button once.
 The Circuit Monitor returns to METERS mode.
7. To accept the new PT rating, press the up arrow SELECT METER [Value] button to change from No to Yes. Then, press the PHASE [Enter] button.

Table 4-2
Supported System Wiring Connections

System Type	# Phase CTs	Aux CT	# PTs	PT Conn.	System Code
3Ø, 3-wire Delta	2	None	2	Open Delta	30
3Ø, 4-wire Wye, Grounded	3	None	3	Wye-Wye	40
3Ø, 4-wire Wye, Grounded	3	1 (Neut)	3	Wye-Wye	41

Setting the System Type

For the Circuit Monitor to meter correctly, you must specify the system connection type. The Circuit Monitor supports three system wiring connections. Table 4-2 shows the system connection types. The factory default is 40.

To change the system type, complete the following steps:

1. Press the MODE button until the red LED next to [Setup] is lit.
The Circuit Monitor displays "ConFig."
2. Press the PHASE [Enter] button to select the Configuration option.
The Circuit Monitor displays the password prompt "P - - - -."
3. Enter the password.
To enter the password, use the SELECT METER [Value] buttons to increase or decrease the displayed value until it reaches the password value. Then press the PHASE [Enter] button.
4. Press the PHASE [Enter] button until the red LED next to [Sys. Type] flashes.
5. Press the SELECT METER [Value] buttons until the system code matching your system type is displayed.
Refer to table 4-2 to determine the system code for your system type.
6. Press the MODE button once.
The red LED next to [Accept] flashes. The red LED next to [Sys. Type] glows steadily.
7. To reject the new system type, press the PHASE [Enter] button once.
The Circuit Monitor returns to METERS mode.
8. To accept the new system type, press the SELECT METER [Value] button to change from *No* to *Yes*. Then, press the PHASE [Enter] button.
The Circuit Monitor restarts.

Setting the Demand Interval

The Circuit Monitor supports several methods to calculate average demand real power. The default method is the thermal demand method. For a description of available demand calculation methods, see **Demand Readings** in Chapter 5.

One optional method is the demand synch pulse input method. In this method, the Circuit Monitor accepts an external synch pulse from another demand meter. The Circuit Monitor then uses the same time interval as the other meter for each demand calculation. For a more detailed description of

PERFORMING RESETS USING THE RESETS OPTION

The Resets option lets you reset energy, demand, and min/max values. The same reset operations can be done using the Configuration option (described on the previous page). The difference is that using the Resets option, you can perform resets only—you cannot change configuration values.

The Resets option is password protected. To access the Resets option, you must enter either the master password, or a special reset password. (See **Setting the Master Password** in this chapter for instructions on defining the master password.)

The reset password can be used to prevent accidental changes to configuration values. For example, you could provide an operator with the reset password only, allowing the operator to perform resets, but not change configuration values.

The reset password defaults to the master password. The Circuit Monitor's factory default master password is 0. Therefore, when you receive a new Circuit Monitor, its reset password is also 0. When you change the master password, the reset password changes to match it. To define a reset password different than the master password, you must write a unique value—in the range 1-9998—to Circuit Monitor register 2031. You can write to register 2031 in one of two ways:

- From a remote PC, using POWERLOGIC application software. (Refer to the software instruction manual for specific instructions on writing to Circuit Monitor registers.)
- From the front panel of the Circuit Monitor, using the Diagnostics option. (See **Appendix K** for instructions on reading and writing registers using the Diagnostics option.)

Important: After you've defined a reset password, you can access the Resets option using either the reset password *or* the master password.

To perform resets, using the Resets option, complete the following steps:

1. Press the MODE button until the red LED next to [Setup] is lit.
The Circuit Monitor displays "ConFig."
2. Press the down arrow SELECT METER button once.
The Circuit Monitor displays "rESETS."
3. Press the PHASE [Enter] button to select the Resets option.
The Circuit Monitor displays the password prompt "P - - - ."
4. Enter either the master password or the reset password.
To enter a password, use the SELECT METER [Value] buttons to increase or decrease the displayed value until it reaches the password value. Then press the PHASE [Enter] button.
5. At this point the procedure is identical to steps 4-9 of the reset procedure described on the previous page. Follow steps 4-9 to perform the desired resets.

SETTING UP ALARM/RELAY FUNCTIONS

The Circuit Monitor (models CM-2150 and higher) can detect over 100 alarm conditions, including over/under conditions, status input changes, phase unbalance conditions, and more. (See **Alarm Conditions and Alarm Codes** in **Appendix I** for a complete listing.)

Each alarm condition can be set up to automatically operate one or more Circuit Monitor relays. Also, multiple alarm conditions can be assigned to operate the same relay(s). For a description of the Circuit Monitor's alarm/relay functions, see **Chapter 7—Alarm Functions**.

You can setup the Circuit Monitor's on-board alarm/relay functions from the Circuit Monitor's front panel. You perform this setup using the Alarm/Relay (ALrLY) option, one of the Circuit Monitor's four setup options. For each alarm condition you can:

- Enable or disable the alarm condition
- Assign a priority level to the alarm condition
- Define any required pickup and dropout setpoints, and pickup and dropout time delays
- Setup the Circuit Monitor to operate up to three relay outputs when the alarm condition occurs

The Circuit Monitor's relay outputs provide ten operating modes. (See **Relay Operating Modes** in **Chapter 6** for descriptions of the modes.) When you assign an alarm condition to operate a relay, from the front panel of the Circuit Monitor, the Circuit Monitor configures the relay to operate in Normal mode. If Normal mode is not acceptable, you'll need to do one of the following:

- Setup the Circuit Monitor's alarm/relay functions over the communications link, using POWERLOGIC application software (which lets you choose from the 10 available modes)
- First setup the alarm/relay functions from the Circuit Monitor's front panel, then change the relay's operating mode by performing register read/writes using either POWERLOGIC application software or the Circuit Monitor's Diagnostics option (see **Appendix K** for instructions on reading and writing registers using the Diagnostics option)

Detailed Setup Procedure (cont.)

You must assign these actions to alarm conditions using POWERLOGIC software.

Depending on the chosen priority level, the Circuit Monitor also performs the actions described below.

P0 - No priority. On the occurrence of a P0 alarm, the Circuit Monitor does the following:

- Puts the alarm number in the list of active alarms, accessible from the front panel (see **Viewing Active Alarms** in **Chapter 4** for instructions on viewing active alarms)

P1 - Highest priority level. On the occurrence of a P1 alarm, the Circuit Monitor does the following:

- Puts the alarm number in the list of active alarms, accessible from the front panel (see **Viewing Active Alarms** in **Chapter 4** for instructions on viewing active alarms)
- Records the occurrence in the Circuit Monitor's event log file
- Enters the alarm number in the P1 log, accessible from the front panel (see **Viewing the Priority 1 Log** in **Chapter 4** for instructions on viewing the P1 log)

P2 - Middle priority level. On the occurrence of a P2 alarm, the Circuit Monitor does the following:

- Puts the alarm number in the list of active alarms, accessible from the front panel (see **Viewing Active Alarms** in **Chapter 4** for instructions on viewing active alarms)
- Records the alarm occurrence in the Circuit Monitor's event log file

P3 - Lowest priority level. On the occurrence of a P3 alarm, the Circuit Monitor does the following:

- Puts the alarm number in the list of active alarms, accessible from the front panel (see **Viewing Active Alarms** in **Chapter 4** for instructions on viewing active alarms)
- Records the alarm occurrence in the Circuit Monitor's event log file

8. Press the PHASE [Enter] button to select the priority level.

The display alternates between "PU SP" (an abbreviation for pickup setpoint) and the setpoint value.

9. Use the SELECT METER [Value] buttons to increase or decrease the displayed value until you reach the desired pickup setpoint.

See **Setpoint-Driven Alarms** in **Chapter 7** for a description of pickup and dropout setpoint and time delays.

If you are configuring an alarm condition that does not require some or all of the pickup and dropout setpoints and delays, for example status input transition alarm conditions, the Circuit Monitor allows you to enter setpoints and delays, but it ignores any values that don't apply.

**Detailed Setup Procedure
(cont.)**

10. Press the PHASE [Enter] button.
The display alternates between "PU dLy" (an abbreviation for pickup delay) and the delay value.
11. Use the SELECT METER [Value] buttons to increase or decrease the displayed value until you reach the desired pickup delay (in seconds).
12. Press the PHASE [Enter] button.
The Circuit Monitor display alternates between "do SP" (an abbreviation for dropout setpoint) and the setpoint value.
13. Use the SELECT METER [Value] buttons to increase or decrease the displayed value until you reach the desired dropout setpoint.
14. Press the PHASE [Enter] button.
The display alternates between "do dLy" (an abbreviation for dropout delay) and the delay value.
15. Use the SELECT METER [Value] buttons to increase or decrease the displayed value until you reach the desired dropout delay (in seconds).
16. Press the PHASE [Enter] button.
The Circuit Monitor displays "r1 No". "r1" stands for relay 1.
17. If you want the Circuit Monitor to operate relay R1 each time the alarm condition occurs, press the up arrow SELECT METER [Value] button to change from No to Yes. Then press the PHASE [Enter] button.
The Circuit Monitor displays "r2 No".
18. If you want the Circuit Monitor to operate relay R2 each time the alarm condition occurs, press the up arrow SELECT METER [Value] button to change from No to Yes. Then press the PHASE [Enter] button.
The Circuit Monitor displays "r3 No".
19. If you want the Circuit Monitor to operate relay R3 each time the alarm condition occurs, press the up arrow SELECT METER [Value] button to change from No to Yes. Then press the PHASE [Enter] button.
The display alternates between "ENABLE" and the priority level.
20. Press the MODE button.
The Circuit Monitor displays "No."
21. To save the configuration changes you just made, press the up arrow SELECT METER [Value] button to change from "No" to "Yes." Then press the PHASE [Enter] button. To discard the changes, press the PHASE [Enter] button.

The Circuit Monitor displays the alarm number. At this point you've completed the configuration process for one alarm condition.

**Detailed Setup Procedure
(cont.)**

22. Repeat steps 5-24 above for each additional alarm condition that you'd like to configure.
23. To leave the Alarm/Relay setup option, press the MODE button while the Circuit Monitor is displaying the "ALr No" prompt.

The Circuit Monitor returns to METERS mode.

VIEWING ACTIVE ALARMS

Each of the Circuit Monitor's alarm conditions has an associated alarm code. The alarm codes of the active alarms can be viewed from the front panel. (The alarm conditions and their associated alarm codes are listed in Appendix I.)

Note: The ALARM mode LED, on the Circuit Monitor's front panel, flashes while at least one of the following conditions is true: a nonzero priority alarm is active, or a priority one alarm has occurred since the last time the priority 1 log was cleared.

To view the active alarm codes, complete the following steps:

1. Press the MODE button until the red LED next to Alarm glows steadily. The Circuit Monitor displays "P1.Log."
2. Press the up arrow SELECT METER [Value] button until "AL.Code" (an abbreviation for *alarm code*) is displayed.
3. Press the PHASE [Enter] button.

The Circuit Monitor displays the lowest active alarm code. If there are no active alarms, the Circuit Monitor displays *-None-*.

Each alarm code is displayed with either an "rLY" extension or an "AL" extension. If you have set up the alarm condition to operate one or more relays, the code appears with an rLY extension (for relay). If you did not set up the alarm condition to operate a relay, the code appears with an AL extension (for alarm only).

4. Press the down arrow SELECT METER [Value] button to cycle through the active alarms.

The Circuit Monitor displays the codes from lowest to highest.

VIEWING THE PRIORITY 1 LOG

To provide a record of high priority alarm occurrences, the Circuit Monitor maintains a *priority 1 log* (P1 log). See **Setting Up Alarm/Relay Functions** in **Chapter 4** for a complete description of the priority levels, and instructions on assigning priority levels from the front panel.

The P1 log stores up to 10 of the last priority 1 alarms. The log operates in a first-in-first-out (FIFO) manner. In other words, when the log is full, the oldest log entry (the *first in*) is removed to make room for the new entry.

When a priority 1 alarm occurs, the Circuit Monitor records it in the P1 log. The alarm remains in the P1 log until one of the following occurs: 10 new P1 alarms occur pushing it out of the log, or you manually clear the P1 log (see **Clearing the Priority 1 Log** on the following page).

Note: The ALARM mode LED, on the Circuit Monitor's front panel, flashes while at least one of the following conditions is true: a nonzero priority alarm is active, or a priority one alarm has occurred since the last time the priority 1 log was cleared.

You can view the P1 log from the Circuit Monitor's front panel. The following procedure tells how.

To view the P1 log, complete the following steps:

1. Press the MODE button until the red LED next to ALARM glows steadily.

The Circuit Monitor displays "P1.Log."

2. Press the PHASE [Enter] button.

The Circuit Monitor displays the alarm code of the lowest priority 1 alarm. If no priority 1 alarms have occurred since the P1 log was last cleared, the Circuit Monitor displays *-None-*.

Each alarm code is displayed with either an "rLY" extension or an "AL" extension. If you have set up the alarm condition to operate one or more relays, the code appears with an rLY extension (for relay). If you did not set up the alarm condition to operate a relay, the code appears with an AL extension (for alarm only).

4. Press the down arrow SELECT METER [Value] button to cycle through the alarm codes.

The Circuit Monitor displays the codes from lowest to highest.

5. To exit the P1 log but remain in the ALARM mode, press the PHASE [Enter] button. To exit the ALARM mode altogether, press the MODE button.

CLEARING THE PRIORITY 1 LOG

To provide a record of high priority alarm occurrences, the Circuit Monitor maintains a *priority 1 log* (P1 log). See **Setting Up Alarm/Relay Functions in Chapter 4** for a complete description of the priority levels, and instructions on assigning priority levels from the front panel. See **Viewing the Priority 1 Log** on the previous page for instructions on viewing the P1 log.

The P1 log stores up to 10 of the last priority 1 alarms. The log operates in a first-in-first-out (FIFO) manner. In other words, when the log is full, the first alarm entry in (the oldest) is the first out.

When a priority 1 alarm occurs, the Circuit Monitor records it in the P1 log. The alarm remains in the P1 log until one of the following occurs: 10 new P1 alarms occur pushing it out of the log, or you manually clear the P1 log. The procedure below tells how to clear the P1 log.

IMPORTANT: Clearing the P1 log causes the Circuit Monitor to release all relays that meet the following conditions:

- The relay must be configured to operate in *latched* mode.
- The relay must be configured for internal control. In other words, you must have set up the Circuit Monitor to operate the relay in response to an alarm condition, or assigned the relay to operate as a pulse initiator output.
- There must be no alarms assigned to operate the relays that are currently active.

To clear the P1 log, complete the following steps:

1. Press the MODE button until the red LED next to ALARM glows steadily.
The Circuit Monitor displays "P1.Log."
2. Press the SELECT METER [Value] buttons until "CLEAR" is displayed.
3. Press the PHASE [Enter] button.
The Circuit Monitor displays "CLr. No".
4. To abort the clear, press the PHASE [Enter] button.
5. To clear the log, press the up arrow SELECT METER [Value] button to change from "CLr. No" to "CLr.YES." Then press the PHASE [Enter] button.

The Circuit Monitor clears the P1 Log, and releases any relays that meet the conditions described above.

CHAPTER 5—METERING CAPABILITIES

CHAPTER CONTENTS

Real-Time Readings	55
Min/Max Values	56
Demand Readings	58
Demand Power Calculation Methods	58
Predicted Demand	59
Peak Demands	59
Energy Readings.....	60
Power Analysis Values	61

REAL-TIME READINGS

The Circuit Monitor measures currents and voltages and reports rms values for all three phases and neutral/ground current. In addition, the Circuit Monitor calculates power factor, real power, reactive power, and more. Table 5-1 lists the real-time readings and their reportable ranges.

Table 5-1
Real-Time Readings

Real-Time Reading	Reportable Range
Current	
Per-Phase	0 to 32,767 A
Neutral	0 to 32,767 A
Ground	0 to 32,767 A
3-Phase Average	0 to 32,767 A
Apparent rms	0 to 32,767 A
Current Unbalance	0 to 100%
Voltage	
Line-to-Line, Per-Phase	0 to 3,276,700 V
Line-to-Neutral, Per-Phase	0 to 3,276,700 V
3-Phase Average	0 to 3,276,700 V
Voltage Unbalance	0 to 100%
Real Power	
3-Phase Total	0 to +/- 3,276.70 MW
Per-Phase	0 to +/- 3,276.70 MW
Reactive Power	
3-Phase Total	0 to +/- 3,276.70 MVAr
Per-Phase	0 to +/- 3,276.70 MVAr
Apparent Power	
3-Phase Total	0 to 3,276.70 MVA
Per-Phase	0 to 3,276.70 MVA
Power Factor (True)	
3-Phase Total	-0.010 to 1.000 to +0.010
Per-Phase	-0.010 to 1.000 to +0.010
Power Factor (Displacement)	
3-Phase Total	-0.010 to 1.000 to +0.010
Per-Phase	-0.010 to 1.000 to +0.010
Frequency	
50/60 Hz	23.00 to 67.00 Hz
Temperature (Internal Ambient)	-100.00 to +100.0 C

DEMAND READINGS

The Circuit Monitor provides a variety of demand readings, including coincident readings and predicted demands. Table 5-2 lists the available demand readings and their reportable ranges.

**Table 5-2
 Demand Readings**

Demand Reading	Reportable Range
Demand Current, Per-Phase	
Present	0 to 32,767 A
Peak	0 to 32,767 A
Avg. Power Factor (True), 3Ø Total	
Present	-0.010 to 1.000 to +0.010
Coincident w/ kW Peak	-0.010 to 1.000 to +0.010
Coincident w/ kVAR Peak	-0.010 to 1.000 to +0.010
Coincident w/ kVA Peak	-0.010 to 1.000 to +0.010
Demand Real Power, 3Ø Total	
Present	0 to +/-3,276.70 MW
Predicted	0 to +/-3,276.70 MW
Peak	0 to +/-3,276.70 MW
Coincident kVA Demand	0 to 3,276.70 MVA
Coincident kVAR Demand	0 to +/-3,276.70 MVAR
Demand Reactive Power, 3Ø Total	
Present	0 to +/-3,276.70 MVAR
Predicted	0 to +/-3,276.70 MVAR
Peak	0 to +/-3,276.70 MVAR
Coincident kVA Demand	0 to 3,276.70 MVA
Coincident kW Demand	0 to +/-3,276.70 MW
Demand Apparent Power, 3Ø Total	
Present	0 to 3,276.70 MVA
Predicted	0 to 3,276.70 MVA
Peak	0 to 3,276.70 MVA
Coincident kW Demand	0 to +/-3,276.70 MW
Coincident kVAR Demand	0 to +/-3,276.70 MVAR

**Demand Power
 Calculation Methods**

To be compatible with electric utility billing practices, the Circuit Monitor provides the following types of demand power calculations:

- Thermal Demand
- Block Interval Demand with Rolling Sub-Interval
- External Pulse Synchronized Demand

The default demand calculation method is Thermal Demand. The Thermal Demand Method and the External Synch Pulse method can be set up from the Circuit Monitor faceplate. (See **Setting the Demand Interval** in Chapter 4 for setup instructions.) Other demand calculation methods can be set up over the communications link. A brief description of each demand method follows.

Demand Power Calculation Methods (cont.)**Thermal Demand:**

The thermal demand method calculates the demand based on a thermal response and updates its demand calculation every 15 seconds on a sliding window basis. The user can select the demand interval from 5 to 60 minutes in 5 minute increments. See **Setting the Demand Interval** in Chapter 4 for instructions. (This is the same method used by the series 100/200 Circuit Monitors.)

Block Interval Demand:

The block interval demand mode supports a standard block interval and an optional subinterval calculation for compatibility with electric utility electronic demand registers.

In the standard block interval mode, the user can select a demand interval from 5 to 60 minutes in 5-minute increments. (See **Setting the Demand Interval** in Chapter 4 for instructions.) The demand calculation is performed at the end of each interval. The present demand value displayed by the Circuit Monitor is the value for the last completed demand interval.

Block Interval Demand with Sub-Interval Option:

When using the block interval method, a demand subinterval can be defined. The user must select both a block interval and a subinterval length. The block interval must be divisible by an integer number of subintervals. (A common selection would be a 15-minute block interval with three 5-minute subintervals.) The block interval demand is recalculated at the end of every subinterval. If the user programs a subinterval of 0, the demand calculation updates every 15 seconds on a sliding window basis.

External Pulse Synchronized Demand:

The Circuit Monitor can be configured to accept—through status input S1—a demand synch pulse from another meter. The Circuit Monitor then uses the same time interval as the other meter for each demand calculation. See **Demand Synch Pulse Input** in Chapter 6 for additional details.

Predicted Demand

The Circuit Monitor calculates predicted demand for kW, kVAr, and kVA. The predicted demand is equal to the average power over a one-minute interval. The predicted demand is updated every 15 seconds.

Peak Demands

The Circuit Monitor maintains, in nonvolatile memory, a running maximum—called “peak demand”—for each average demand current and average demand power value. It also stores the date and time of each peak demand. In addition to the peak demand, the Circuit Monitor stores the coinciding average (demand) 3-phase power factor. The average 3-phase power factor is defined as “demand kW/demand kVA” for the peak demand interval.

Peak demand values can be reset from the Circuit Monitor front panel, or over the communications link using POWERLOGIC application software. To reset peak demand values from the Circuit Monitor front panel, see **Resetting Demand, Energy, and Min/Max Values** in Chapter 4.

ENERGY READINGS

The Circuit Monitor provides energy values for kWh and kVARH. These values can be displayed on the Circuit Monitor, or read over the communications link.

The Circuit Monitor can accumulate these energy values in one of two modes: signed or unsigned (absolute). In signed mode, the Circuit Monitor considers the direction of power flow, allowing the accumulated energy magnitude to both increase and decrease. In unsigned mode, the Circuit Monitor accumulates energy as positive, regardless of the direction of power flow; in other words, the energy value increases, even during reverse power flow. The default accumulation mode is unsigned.

The Circuit Monitor provides additional energy readings that are available over the communications link only. They are:

- *Directional accumulated energy readings.* The Circuit Monitor calculates and stores in nonvolatile memory accumulated values for energy (kWH) and reactive energy (kVARH) both into and out of the load. The Circuit Monitor also calculates and stores apparent energy (kVAH).
- *Conditional accumulated energy readings.* Using these values, energy accumulation can be turned off or on for special metering applications. Accumulation can be turned on over the communications link, or activated from a status input change. The Circuit Monitor stores the date and time of the last reset of conditional energy in nonvolatile memory.
- *Incremental accumulated energy readings.* The real, reactive and apparent incremental energy values reflect the energy accumulated during the last incremental energy period. The increment start time and time interval can be defined by the user. Incremental energy values can be logged in Circuit Monitor memory (models CM-2150 and up) and used for load-profile analysis.

**Table 5-3
 Energy Readings**

Energy Reading, 3-Phase	Reportable Range
Accumulated Energy	
Real (Signed/Absolute)	0 to 9,999,999,999,999 WHR
Reactive (Signed/Absolute)	0 to 9,999,999,999,999 VARH
Real (In)	0 to 9,999,999,999,999 WHR
Real (Out)	0 to 9,999,999,999,999 WHR
Reactive (In)	0 to 9,999,999,999,999 VARH
Reactive (Out)	0 to 9,999,999,999,999 VARH
Apparent	0 to 9,999,999,999,999 VAH
Accumulated Energy, Conditional	
Real (In)	0 to 9,999,999,999,999 WHR
Real (Out)	0 to 9,999,999,999,999 WHR
Reactive (In)	0 to 9,999,999,999,999 VARH
Reactive (Out)	0 to 9,999,999,999,999 VARH
Apparent	0 to 9,999,999,999,999 VAH
Accumulated Energy, Incremental	
Real (In)	0 to 999,999,999,999 WHR
Real (Out)	0 to 999,999,999,999 WHR
Reactive (In)	0 to 999,999,999,999 VARH
Reactive (Out)	0 to 999,999,999,999 VARH
Apparent	0 to 999,999,999,999 VAH

POWER ANALYSIS VALUES

The Circuit Monitor provides a number of power analysis values that can be used to detect and prevent power quality problems, diagnose wiring problems, and more. Table 5-4 summarizes the power analysis values.

THD—Total Harmonic Distortion (THD) is a quick measure of the total distortion present in a waveform. It provides a general indication of the “quality” of a waveform. The Circuit Monitor uses the following equation to calculate THD:

$$\text{THD} = \frac{\sqrt{H_2^2 + H_3^2 + H_4^2 + \dots}}{H_1} \times 100\%$$

thd—An alternate method for calculating Total Harmonic Distortion, used widely in Europe. The Circuit Monitor uses the following equation to calculate thd:

$$\text{thd} = \frac{\sqrt{H_2^2 + H_3^2 + H_4^2 + \dots}}{\text{Total rms}} \times 100\%$$

K-Factor—K-Factor is a simple numerical rating used to specify transformers for nonlinear loads. The Circuit Monitor uses the following formula to calculate K-Factor:

$$K = \frac{\text{SUM } (I_h)^2 h^2}{I_{\text{rms}}^2}$$

Displacement Power Factor—For purely sinusoidal loads, the power factor calculation kW/kVA is equal to the cosine of the angle between the current and voltage waveforms. For harmonically distorted loads, the true power factor equals kW/kVA—but this may not equal the angle between the fundamental components of current and voltage. The displacement power factor is based on the angle between the fundamental components of current and voltage.

Table 5-4
Power Analysis Values

Value	Reportable Range
THD-Voltage, Current	
3-phase, per-phase, neutral	0 to 327.67%
thd-Voltage, Current	
3-phase, per-phase, neutral	0 to 100.00%
K-Factor (per phase)	0.0 to 100.0
K-Factor Demand (per phase)	0.0 to 100.0
Crest Factor (per phase)	0.0 to 100.0
Displacement P.F. (per phase, 3 phase)	-0.010 to 1.000 to +0.010
Fundamental Voltages (per phase)	
Magnitude	0 to 3,276,700 V
Angle	0.0 to 359.9 degrees
Fundamental Currents (per phase)	
Magnitude	0 to 32,767 A
Angle	0.0 to 359.9 degrees
Fundamental Real Power (per phase, 3 phase)	327,670 kW
Fundamental Reactive Power (per phase)	0 to 327,670 kVAR
Harmonic Power (per phase, 3 phase)	0 to 327,670 kW
Phase Rotation	ABC or CBA
Unbalance (current and voltage)	0.0 to 100%

CHAPTER 6—INPUT/OUTPUT CAPABILITIES

CHAPTER CONTENTS

Input/Output Modules	62
Status Inputs	63
Demand Synch Pulse Input	64
Pulse Demand Metering	65
Analog Inputs	67
Relay Output Operating Modes.....	69
Mechanical Relay Outputs	71
Setpoint Controlled Relay Functions	72
Solid State KYZ Pulse Output	73
2-Wire Pulse Initiator	73
3-Wire Pulse Initiator	74
Calculating the Watthour-per-pulse Value	75
Analog Outputs	76

INPUT/OUTPUT MODULES

The Circuit Monitor supports a variety of input/output options through the use of add-on I/O modules. The I/O modules attach to the back of the Circuit Monitor. Each I/O module provides some or all of the following:

- Status Inputs
- Mechanical Relay Outputs
- Solid State KYZ Pulse Output
- Analog Inputs
- Analog Outputs

Table 6-1 lists the available I/O Modules. The remainder of this chapter describes the I/O capabilities. For module installation instructions and detailed technical specifications, see **Appendix B—Installing and Wiring Optional I/O Modules**.

Table 6-1
Input/Output Modules

Class	Type	Description
3020	IOM-11	1 status IN, 1 KYZ pulse OUT
3020	IOM-18	8 status IN, 1 KYZ pulse OUT
3020	IOM-44	4 status IN, 1 KYZ pulse OUT, 3 Form-C relay OUT
3020	IOM-4411-01	4 status IN, 1 KYZ pulse OUT, 3 Form-C relay OUT, 1 Analog IN [Ⓞ] , 1 Analog OUT (0–1 mA)
3020	IOM-4411-20	4 status IN, 1 KYZ pulse OUT, 3 Form-C relay OUT, 1 Analog IN [Ⓞ] , 1 Analog OUT (4–20 mA)
3020	IOM-4444-01	4 status IN, 1 KYZ pulse OUT, 3 Form-C relay OUT, 4 Analog IN [Ⓞ] , 4 Analog OUT (0–1 mA)
3020	IOM-4444-20	4 status IN, 1 KYZ pulse OUT, 3 Form-C relay OUT, 4 Analog IN [Ⓞ] , 4 Analog OUT (4–20 mA)

[Ⓞ] Analog Inputs are 0-5 Vdc. Each analog input can be independently configured to accept a 4-20 mA input by connecting an external jumper wire. See **Analog Inputs** in this chapter for more information.

STATUS INPUTS

The Circuit Monitor's I/O modules offer 1, 4, or 8 status inputs (see Table 6-1 on the previous page). Status inputs can be used to detect breaker status, count pulses, count motor starts, and so on.

The following are important points about the Circuit Monitor's status inputs:

- The Circuit Monitor maintains a counter of the total transitions for each status input.
- Status input S2 is a high-speed status input. Input S2 can be tied to an external relay used to trigger the Circuit Monitor's 12-cycle event capture feature (see **12-Cycle Event Capture** on in Chapter 9). **Note:** The IOM-11 module does not have an input S2.
- Status input transitions can be logged as events in the Circuit Monitor's on-board event log.
- Status input transition events are date and time stamped. For the IOM-11, IOM-18, and IOM-44, the date and time are accurate to within one second—except for input S2 transition events. Input S2 transition events are time stamped with accuracy to the millisecond. For the IOM-4411 and IOM-4444, all status input transition events are time stamped with accuracy to the millisecond, for sequence of events recording.
- Status input S1 can be configured (from the Circuit Monitor front panel) to accept a demand synch pulse from a utility demand meter (see **Demand Synch Pulse Input** on the following page).
- Status inputs can be configured to control conditional energy (see **Conditional Energy** in Chapter 12 for more information).
- Status inputs can be used to count KYZ pulses for demand and energy calculation. By mapping multiple inputs to the same counter register, the Circuit Monitor can totalize pulses from multiple inputs (see **Pulse Demand Metering** in Chapter 6 for more information).

DEMAND SYNCH PULSE INPUT

The Circuit Monitor can be configured to accept—through status input S1—a demand synch pulse from another demand meter. By accepting the demand synch pulses, the Circuit Monitor can make its demand interval “window” match the other meter’s demand interval “window.” The Circuit Monitor does this by “watching” status input S1 for a pulse from the other demand meter. When it sees a pulse, it starts a new demand interval and calculates the demand for the preceding interval. The Circuit Monitor then uses the same time interval as the other meter for each demand calculation. Figure 6-1 illustrates this point.

When in this mode, the Circuit Monitor will not start or stop a demand interval without a pulse. The maximum allowable time between pulses is 60 minutes. If 61 minutes pass before a synch pulse is received, the Circuit Monitor throws out the demand calculations and begins a new calculation when the next pulse is received. Once in synch with the other meter, the Circuit Monitor can be used to verify peak demand charges.

Important facts about the Circuit Monitor’s demand synch feature are listed below:

- The demand synch feature can be activated from the Circuit Monitor’s front panel. To activate the feature, enter a demand interval of zero. (See **Setting the Demand Interval** in Chapter 4 for instructions.)
- When the Circuit Monitor’s demand interval is set to zero, the Circuit Monitor automatically looks to input S1 for the demand synch pulse. The synch pulse output on the other demand meter *must* be wired to Circuit Monitor input S1. (See **Appendix B—Installing and Wiring Optional I/O Modules** for wiring instructions.)
- The maximum allowable interval between pulses is 60 minutes.

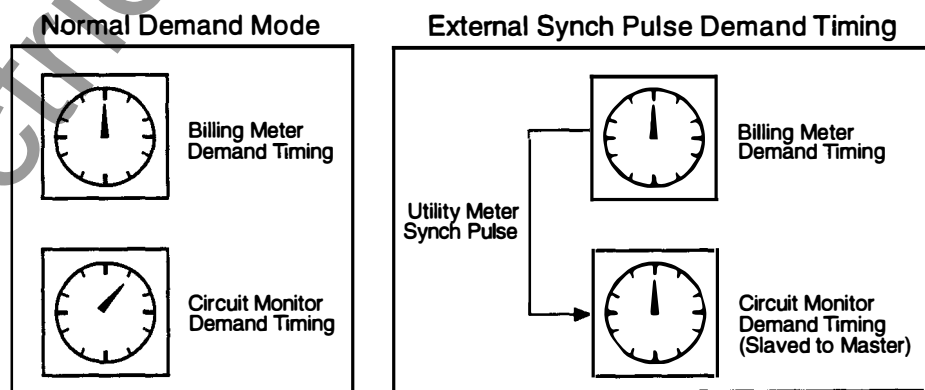

Figure 6-1: Demand synch pulse timing

PULSE DEMAND METERING When equipped with an I/O module, the Circuit Monitor can count pulses from an external source, such as a utility watt-hour meter. This allows the Circuit Monitor to keep track of demand information by counting pulses.

The Circuit Monitor provides ten channels (see figure 6-2). Each channel maintains pulse count data taken from one or more status inputs. For each channel, the Circuit Monitor maintains the following information:

- Present Demand Pulse Count—the number of pulses counted so far during the present demand interval.
- Last Completed Interval Pulse Count—the number of pulses counted during the last completed demand interval.
- Peak Demand Pulse Count—the maximum number of pulses counted during a completed interval since the last demand reset.
- Date/Time of Peak—the date and time of the peak demand pulse count (described above) since the last demand reset.

For each channel, the user can define the following information:

- Units—for example, kWh, kVARh, or kVAh.
- Weight factor—a weight factor for each pulse. For example, you might define that each pulse is equal to 10 kW.
- Status inputs to be monitored—the inputs assigned to the channel. A single channel can count pulses from one status input, or from multiple status inputs for totalization.

Pulse Counting Example

Figure 6-2, on the following page, shows how a user might apply the pulse demand metering feature. In the example, channels 1, 2 have been assigned to count pulses from inputs S1 and S2, respectively. Channel 10 has been assigned inputs S1 and S2. Therefore, channel 10 will totalize the pulses from S1 and S2.

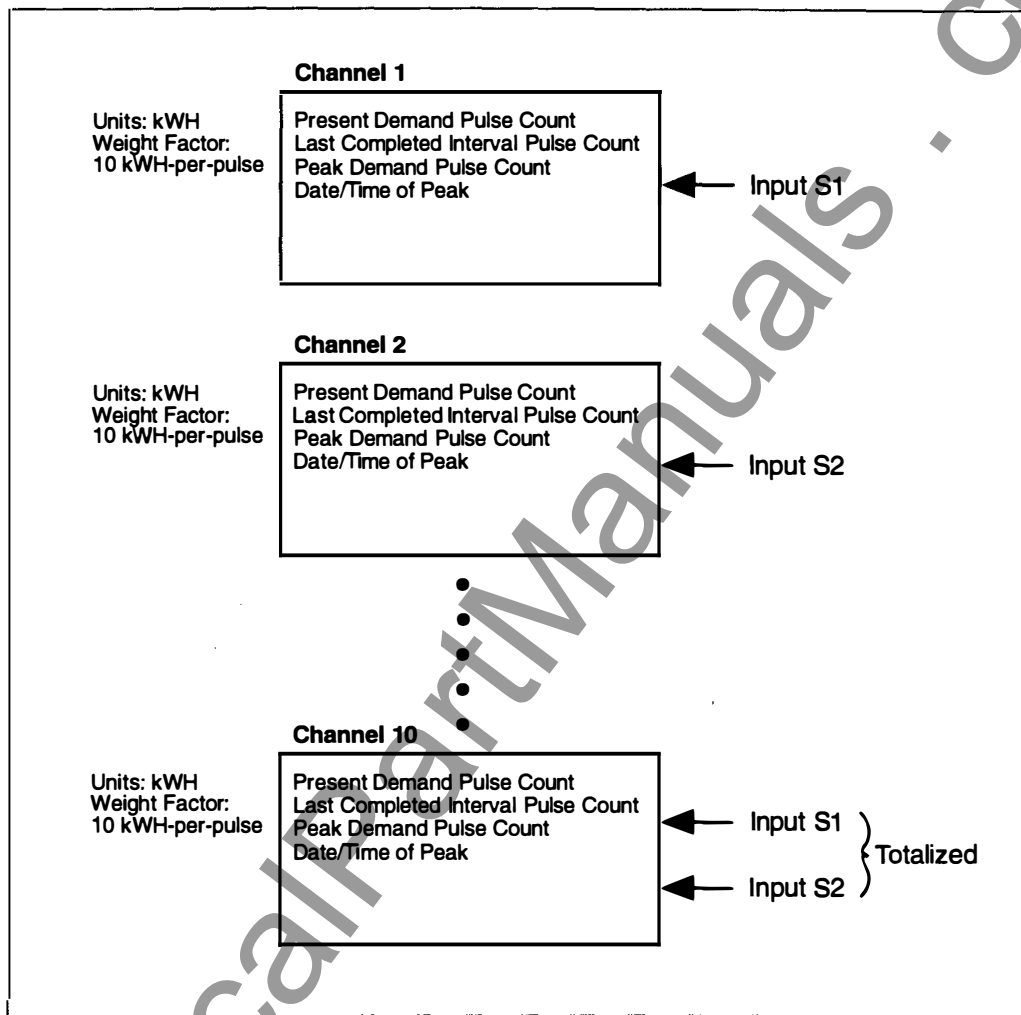

Figure 6-2: Pulse Demand Metering Example

ANALOG INPUTS

The Circuit Monitor supports analog inputs through the use of optional input/output modules. I/O module IOM-4411 offers one analog input. I/O module IOM-4444 offers four analog inputs. Table 6-1, on page 62, lists the available input/output modules.

This section describes the Circuit Monitor's analog input capabilities. For technical specifications and instructions on installing the modules, see **Appendix B—Installing and Wiring Optional I/O Modules**.

Each analog input can accept either a 0–5 Vdc voltage input, or a 4–20 mA dc current input. By default, the analog inputs accept a 0–5 Vdc input. To change an analog input to accept a 4–20 mA signal, the user must connect a jumper wire to the appropriate terminals on the input module. The jumper wire places a 250 ohm resistor (located inside the I/O module) into the circuit. When a 4–20 mA current is run through the resistor, the Circuit Monitor measures an input voltage of 1–5 volts across the resistor. See **Appendix B—Installing and Wiring Optional I/O Modules** for instructions on connecting the jumper wire.

To setup analog inputs, application software is required. Using POWERLOGIC application software, the user must define the following values for each analog input:

- **Units**—A six character label used to identify the units of the monitored analog value (for example, "PSI").
- **Input Type (0-5 V or 4-20 mA)**—Tells the Circuit Monitor whether to use the default calibration constants, or the alternate calibration constants for the internal 250 ohm resistor.
- **Upper Limit**—The value the Circuit Monitor reports when the input voltage is equal to 5 volts (the maximum input voltage).
- **Lower Limit**—The value the Circuit Monitor reports when the input voltage is equal to the *offset voltage*, defined below.
- **Offset Voltage**—The lowest input voltage (in hundredths of a volt) that represents a valid reading. When the input voltage is equal to this value, the Circuit Monitor reports the *lower limit*, defined above.
- **Precision**—The precision of the measured analog value (for example, tenths of degrees Celsius).

The following are important facts regarding the Circuit Monitor's analog input capabilities:

- When the input voltage is below the offset voltage, the Circuit Monitor reports -32,768; POWERLOGIC application software indicates that the reading is invalid by displaying N/A or asterisks.
- When the input voltage is above five volts (the maximum input voltage) the Circuit Monitor reports the upper limit.
- Gain and offset values for each analog input can be adjusted by the user. This is not required, but can be used to compensate for transducer error.

Analog Input Example

Figure 6-3 shows an analog input example. In this example, the analog input has been configured as follows:

Upper Limit: 500
Lower Limit: 100
Offset Voltage: 1 Volt
Units: PSI

The table below shows Circuit Monitor readings at various input voltages.

<u>Input Voltage</u>	<u>Circuit Monitor Reading</u>
.5 V	-32,768 (invalid)
1 V	100 PSI
2 V	200 PSI
2.5 V	250 PSI
5 V	500 PSI
5.5 V	500 PSI

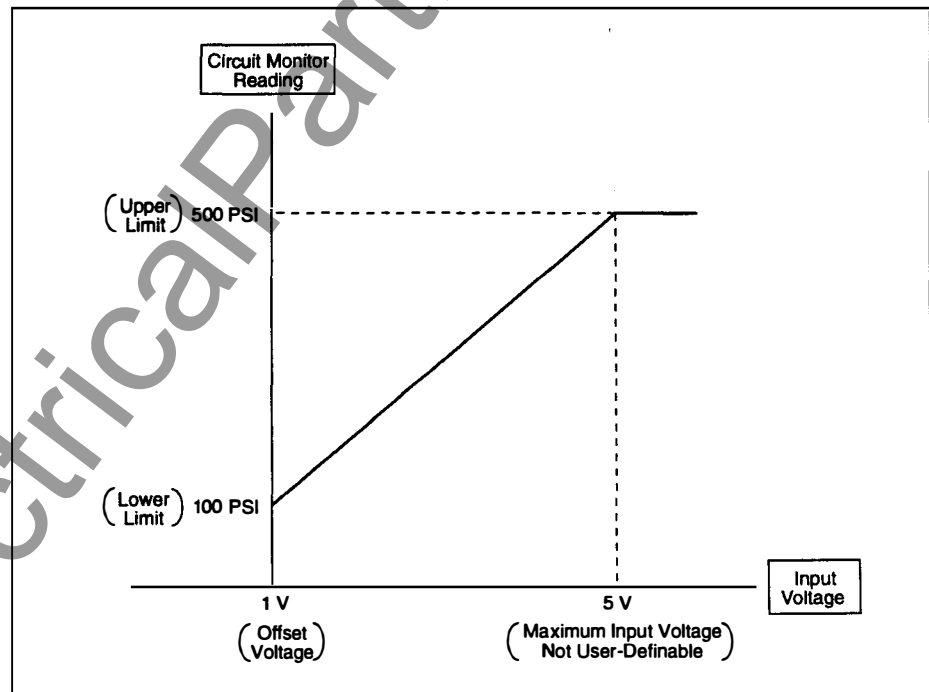

Figure 6-3: Analog Input example

RELAY OUTPUT OPERATING MODES

Before we describe the nine available relay operating modes, it is important to understand the difference between a relay configured for *remote (external) control* and a relay configured for *Circuit Monitor (internal) control*.

Each mechanical relay output must be configured for one of the following

1. Remote (external) control—the relay is controlled either from a PC using POWERLOGIC application software, or using a programmable controller
2. Circuit Monitor (internal) control—the relay is controlled by the Circuit Monitor (models CM-2150 and above), in response to an alarm condition, or as a pulse initiator output

Once you've set up a relay for Circuit Monitor control (option 2 above), you can no longer operate the relay remotely. You can, though, temporarily override the relay, using POWERLOGIC application software.

The first three operating modes—normal, latched, and timed—function differently when the relay is *remotely* controlled versus *Circuit Monitor* controlled. The descriptions below point out the differences in remote versus Circuit Monitor control. Modes 4 through 10—all pulse initiation modes—are Circuit Monitor control modes; remote control does not apply to these modes.

1. Normal

Remotely Controlled: The user must energize the relay by issuing a command from a remote PC or programmable controller. The relay remains energized until a command to de-energize is issued from a remote PC or programmable controller, or until the Circuit Monitor loses control power.

Circuit Monitor Controlled: When an alarm condition assigned to the relay occurs, the relay is energized. The relay is not de-energized until *all* alarm conditions assigned to the relay have dropped out, or until the Circuit Monitor loses control power.

2. Latched

Remotely Controlled: The user must energize the relay by issuing a command from a remote PC or programmable controller. The relay remains energized until a command to de-energize is issued from a remote PC or programmable controller, or until the Circuit Monitor loses control power.

Circuit Monitor Controlled: When an alarm condition assigned to the relay occurs, the relay is energized. The relay remains energized—even after all alarm conditions assigned to the relay have dropped out—until a command to de-energize is issued from a remote PC or programmable controller, or until the Circuit Monitor loses control power.

3. Timed

Remotely Controlled: The user must energize the relay by issuing a command from a remote PC or programmable controller. The relay remains energized until the timer expires, or until the Circuit Monitor loses control power. If a new command to energize the relay is issued before the timer expires, the timer restarts.

Circuit Monitor Controlled: When an alarm condition assigned to the relay occurs, the relay is energized. The relay remains energized for the duration of the timer. When the timer expires, if the alarm has dropped out, the relay will de-energize and remain de-energized. However, if the alarm is still active when the relay timer expires, the relay will de-energize and rapidly re-energize; this sequence will repeat until the alarm condition drops out.

4. Absolute kWH Pulse

This mode assigns the relay to operate as a pulse initiator with a user-defined number of kWH per pulse. In this mode, both forward and reverse energy are treated as additive (as in a tie breaker).

5. Absolute kVARH Pulse

This mode assigns the relay to operate as a pulse initiator with a user-defined number of kVARH per pulse. In this mode, both forward and reverse energy are treated as additive (as in a tie breaker).

6. kVAH Pulse

This mode assigns the relay to operate as a pulse initiator with a user-defined number of kVAH per pulse. Since kVA has no sign, there is only one mode for kVAH pulse.

7. kWH In Pulse

This mode assigns the relay to operate as a pulse initiator with a user-defined number of kWH per pulse. In this mode, only the kWH flowing *into* the load is considered.

8. kVARH In Pulse

This mode assigns the relay to operate as a pulse initiator with a user-defined number of kVARH per pulse. In this mode, only the kVARH flowing *into* the load is considered.

9. kWH Out Pulse

This mode assigns the relay to operate as a pulse initiator with a user-defined number of kWH per pulse. In this mode, only the kWH flowing *out of* the load is considered.

10. kVAr Out Pulse

This mode assigns the relay to operate as a pulse initiator with a user-defined number of kVARH per pulse. In this mode, only the kVARH flowing *out of* the load is considered.

**MECHANICAL RELAY
OUTPUTS**

Input/Output module IOM-44 provides three Form-C 10A mechanical relays that can be used to open or close circuit breakers, annunciate alarms, and more. Table 6-1 on page 62 lists the available Input/Output modules. **Appendix B** tells how to install and wire the I/O modules.

Circuit Monitor mechanical output relays can be configured to operate in one of nine operating modes:

- Normal
- Latched (Electrically Held)
- Timed
- Absolute kWh pulse
- Absolute kVarH pulse
- kVAH pulse
- kWh in pulse
- kVARH in pulse
- kWh out pulse
- kVAr out pulse

See the previous section for a description of the modes.

The last six modes in the above list are for pulse initiator applications. Keep in mind that all Circuit Monitor Input/Output modules provide a solid-state KYZ pulse output rated at 96 mA. The solid-state KYZ output provides the long life—billions of operations—required for pulse initiator applications. The mechanical relay outputs have limited lives: 10 million operations under no load; 100,000 under load. For maximum life, use the solid-state KYZ pulse output for pulse initiation, except when a rating higher than 96 mA is required. See **Solid State KYZ Pulse Output** in this chapter for a description of the solid-state KYZ pulse output.

Setpoint Controlled Relay Functions

The Circuit Monitor can detect over 100 alarm conditions, including over under conditions, status input changes, phase unbalance conditions, and more (see **Chapter 7—Alarm Functions**). Using POWERLOGIC application software, an alarm condition can be assigned to automatically operate one or more relays. For example, you could setup the alarm condition "Undervoltage Phase A" to operate relays R1, R2, and R3. Then, each time the alarm condition occurs—that is, each time the setpoints and time delays assigned to Undervoltage Phase A are satisfied—the Circuit Monitor automatically operates relays R1, R2, and R3 per their configured mode of operation. (See **Relay Operating Modes** in this chapter for a description of the operating modes.)

Also, multiple alarm conditions can be assigned to a single relay. For example, the alarm conditions "Undervoltage Phase A" and "Undervoltage Phase B" could both be assigned to operate relay R1. The relay remains energized as long as either "Undervoltage Phase A" or "Undervoltage Phase B" remains true.

NOTE
Setpoint-controlled relay operation can be used for some types of non-time-critical protective relaying. For more information, see Protective Functions in Chapter 7 .

SOLID-STATE KYZ PULSE OUTPUT

This section describes the Circuit Monitor's pulse output capabilities. For instructions on wiring the KYZ pulse output, see **Appendix B—Installing and Wiring Optional I/O Modules**.

Input/Output modules IOM-11, IOM-18, and IOM-44 are all equipped with one solid-state KYZ pulse output contact (see Table 6-1 on page 62). This solid-state relay provides the extremely long life—billions of operations—required for pulse initiator applications.

The KYZ output is a Form-C contact with a maximum rating of 96 mA. Since most pulse initiator applications feed solid state receivers with very low burdens, this 96 mA rating is generally adequate. For applications where a rating higher than 96 mA is required, the IOM-44 provides 3 relays with 10 amp ratings. Any of the 10 amp relays can be configured as a pulse initiator output, using POWERLOGIC application software. Keep in mind that the 10 amp relays are mechanical relays with limited life—10 million operations under no load; 100,000 under load.

The watthour-per-pulse value can be set from the Circuit Monitor's front panel. When setting the kWh/pulse value, set the value based on a 3-wire pulse output basis. See **Setting the Watthour Pulse Output** in **Chapter 4** for instructions. See **Calculating the Watthour Per Pulse Value** in this chapter for instructions on calculating the correct value.

The Circuit Monitor can be used in 2-wire or 3-wire pulse initiator applications. Each of these applications is described below.

2-Wire Pulse Initiator

Most energy management system digital inputs use only two of the three wires provided with a KYZ pulse initiator. This is referred to as a 2-wire pulse initiator application. Figure 6-4 shows a pulse train from a 2-wire pulse initiator application. Refer to this figure when reading the following points:

- In a 2-wire application, the pulse train looks like alternating open and closed states of a Form-A contact.
- Most 2-wire KYZ pulse applications use a Form-C contact, but tie into only one side of the Form-C contact.
- The pulse is defined as the transition from OFF to ON of one side of the Form-C relay.
- In figure 6-4, the transitions are marked as 1 and 2. Each transition represents the time when the relay flip-flops from KZ to KY. At points 1 and 2, the receiver should count a pulse.
- In a 2-wire application, the Circuit Monitor can deliver up to 5 pulses per second.

3-Wire Pulse Initiator

Some pulse initiator applications require all three wires provided with a KYZ pulse initiator. This is referred to as a 3-wire pulse initiator application. Figure 6-5 shows a pulse train for a 3-wire pulse initiator application. Refer to this figure when reading the following points:

- 3-wire KYZ pulses are defined as transitions between KY and KZ.
- These transitions are alternate contact closures or "flip-flops" of a Form-C contact.
- In figure 6-5 the transitions are marked as 1, 2, 3, and 4. Each transition represents the time when the relay flip flops from KY to KZ, or from KZ to KY. At points 1, 2, 3, and 4, the receiver should count a pulse.
- In a 3-wire application, the Circuit Monitor can deliver up to 10 pulses per second.

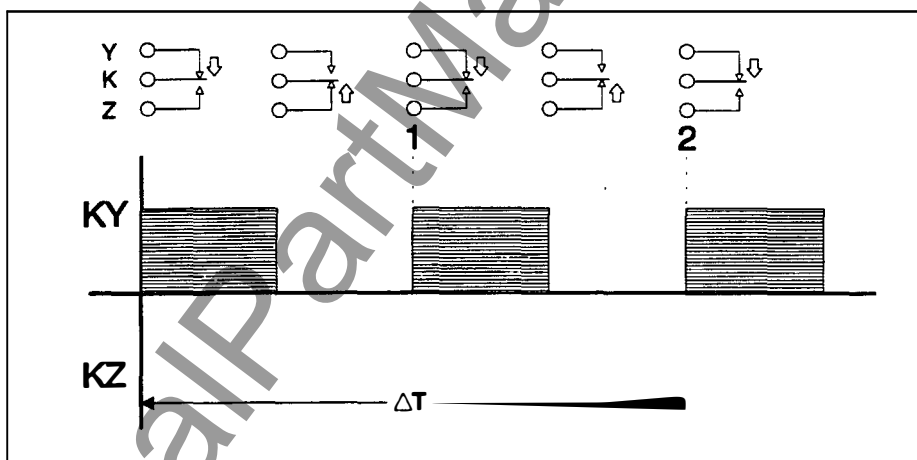

Figure 6-4: 2-wire pulse train

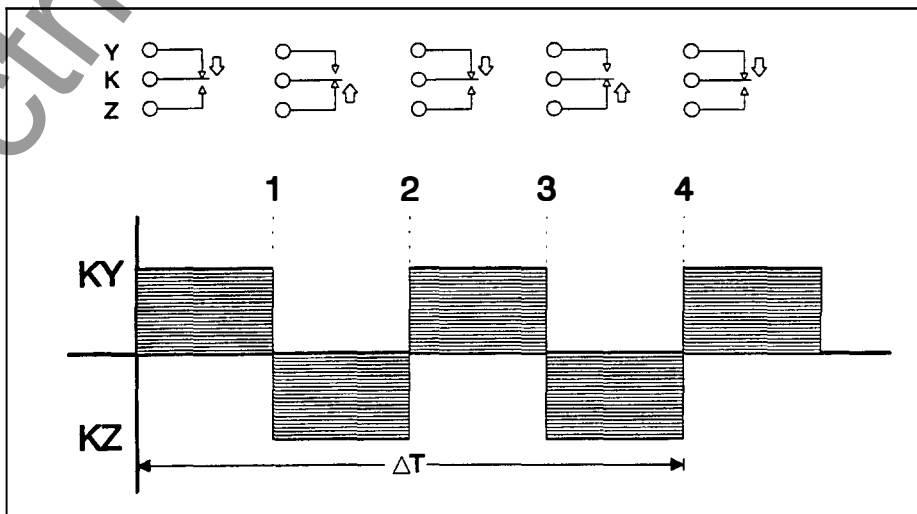

Figure 6-5: 3-wire pulse train

Calculating the Watthour-Per-Pulse Value

This section shows an example of how to calculate the watthour-per-pulse value. To calculate this value, first determine the highest kW value you can expect and the required pulse rate. In this example, the following assumptions are made:

- The metered load should not exceed 1500 kW.
- The KYZ pulses should come in at about two pulses per second at full scale.

Step 1: Translate 1500 kW load into kWh/second.

$$(1500 \text{ kW}) (1 \text{ Hr}) = 1500 \text{ kWh}$$

$$\frac{(1500 \text{ kWh})}{1 \text{ hour}} = \frac{\text{"X" kWh}}{1 \text{ second}}$$

$$\frac{(1500 \text{ kWh})}{3600 \text{ seconds}} = \frac{\text{"X" kWh}}{1 \text{ second}}$$

$$X = 1500/3600 = 0.4167 \text{ kWh/second}$$

Step 2: Calculate the kWh required per pulse.

$$\frac{0.4167 \text{ kWh/second}}{2 \text{ pulses/second}} = 0.2084 \text{ kWh/pulse}$$

Step 3: Round to nearest tenth, since the Circuit Monitor only accepts 0.1 kWh increments.

$$K_e = 0.2 \text{ kWh/pulse}$$

Summary:

- 3-wire basis—0.2 kWh/pulse will provide approximately 2 pulses per second at full scale.
- 2-wire basis—0.1 kWh/pulse will provide approximately 2 pulses per second at full scale. (To convert to the kWh/pulse required on a 2-wire basis, divide K_e by 2. This is required since the Circuit Monitor delivers two pulses—KY and KZ—for every pulse that is counted on a 2-wire basis.)

ANALOG OUTPUTS

The Circuit Monitor supports analog outputs through the use of optional input/output modules. I/O modules IOM-4411-20 and IOM-4444-20 offer one and four 0-20 mA analog outputs, respectively. I/O modules IOM-4411-01 and IOM-4444-01 offer one and four 0-1 mA analog outputs, respectively. Table 6-1, on page 62, lists the available input/output modules.

This section describes the Circuit Monitor's analog output capabilities. For technical specifications and instructions on installing the modules, see **Appendix B—Installing and Wiring Optional I/O Modules**.

To setup analog outputs, application software is required. Using POWERLOGIC application software, the user must define the following values for each analog output:

- **Analog Output Label**—A four character label used to identify the output.
- **Output Range**—The range of the output current: 4-20 mA, for the IOM-4411-20 and IOM-4444-20; 0-1 mA, for the IOM-4411-01 and IOM-4444-01.
- **Register Number**—The Circuit Monitor register number assigned to the analog output.
- **Lower Limit**—The register value that is equivalent to the minimum output current (0 or 4 mA).
- **Upper Limit**—The register value that is equivalent to the maximum output current (1 mA or 20 mA).

The following are important facts regarding the Circuit Monitor's analog output capabilities:

- When the register value is below the *lower limit*, the Circuit Monitor outputs the minimum output current (0 or 4 mA).
- When the register value is above the *upper limit*, the Circuit Monitor outputs the maximum output current (1 mA or 20 mA).
- Gain and offset values for each analog output can be adjusted by the user.

Analog Output Example

Figure 6-6, on the following page, illustrates the relationship between the output range and the upper and lower limit. In this example, the analog output has been configured as follows:

Output Range:	4-20 mA
Register Number:	1042 (Real Power, 3-Phase Total)
Lower Limit:	100 kW
Upper Limit:	500 kW

The table on the next page shows the output current at various register readings.

Register Reading	Output Current
50 kW	4 mA
100 kW	4 mA
200 kW	8 mA
300 kW	12 mA
500 kW	20 mA
550 kW	20 mA

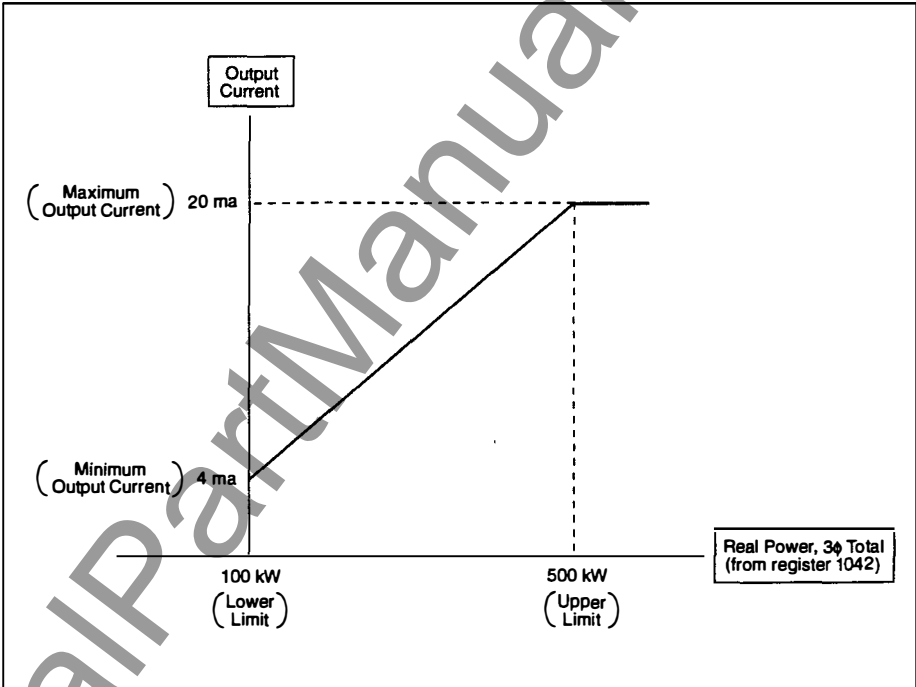

Figure 6-6: Analog output example

CHAPTER 7—ALARM FUNCTIONS

The Circuit Monitor (models CM-2150 and higher) can detect over 100 alarm conditions, including over/under conditions, status input changes, phase unbalance conditions, and more. (See **Alarm Conditions and Alarm Codes** in **Appendix I** for a complete list of alarm conditions.) The Circuit Monitor maintains a counter for each alarm to keep track of the total number of occurrences.

These alarm conditions are the tools that let the Circuit Monitor execute tasks automatically. Using POWERLOGIC application software, each alarm condition can be assigned one or more of the following tasks.

- Force data log entries in up to 14 user-defined data log files (see **Data Logging** in **Chapter 8**)
- Operate one or more mechanical relays (see **Mechanical Relay Outputs** in **Chapter 6**)
- Perform a 4-cycle waveform capture (see **4-Cycle Waveform Capture** in **Chapter 9**)
- Perform a 12-cycle waveform capture (see **12-cycle Event Capture** in **Chapter 9**)

SETPOINT-DRIVEN ALARMS

Many of the alarm conditions—including all over, under, and phase unbalance alarm conditions—require that you define setpoints. Other alarm conditions, such as status input transitions and phase reversals do not require setpoints. For those alarm conditions that require setpoints, you must define the following information:

- Pickup Setpoint
- Pickup Delay (in seconds)
- Dropout Setpoint
- Dropout Delay (in seconds)

For instructions on setting up alarm/relay functions from the Circuit Monitor front panel, see **Setting Up Alarm/Relay Functions** in **Chapter 4**.

To understand how the Circuit Monitor handles setpoint-driven alarms, see figure 7-2. Figure 7-1 shows what the actual event log entries for figure 7-2 might look like, as displayed by POWERLOGIC application software.

Note: The software would not actually display the codes in parentheses—EV1, EV2, M1, M2. These are references to the codes in figure 7-2.

	Priority	Description	Entry/Exit	Value Reached
4/15/93 08:43:12 AM (EV1)	1	Over Current Demand Phase A	Entry	259 (Max1)
4/15/93 08:46:05 AM (EV 2)	1	Over Current Demand Phase A	Exit	302 (Max2)

Figure 7-1: Sample event log entry

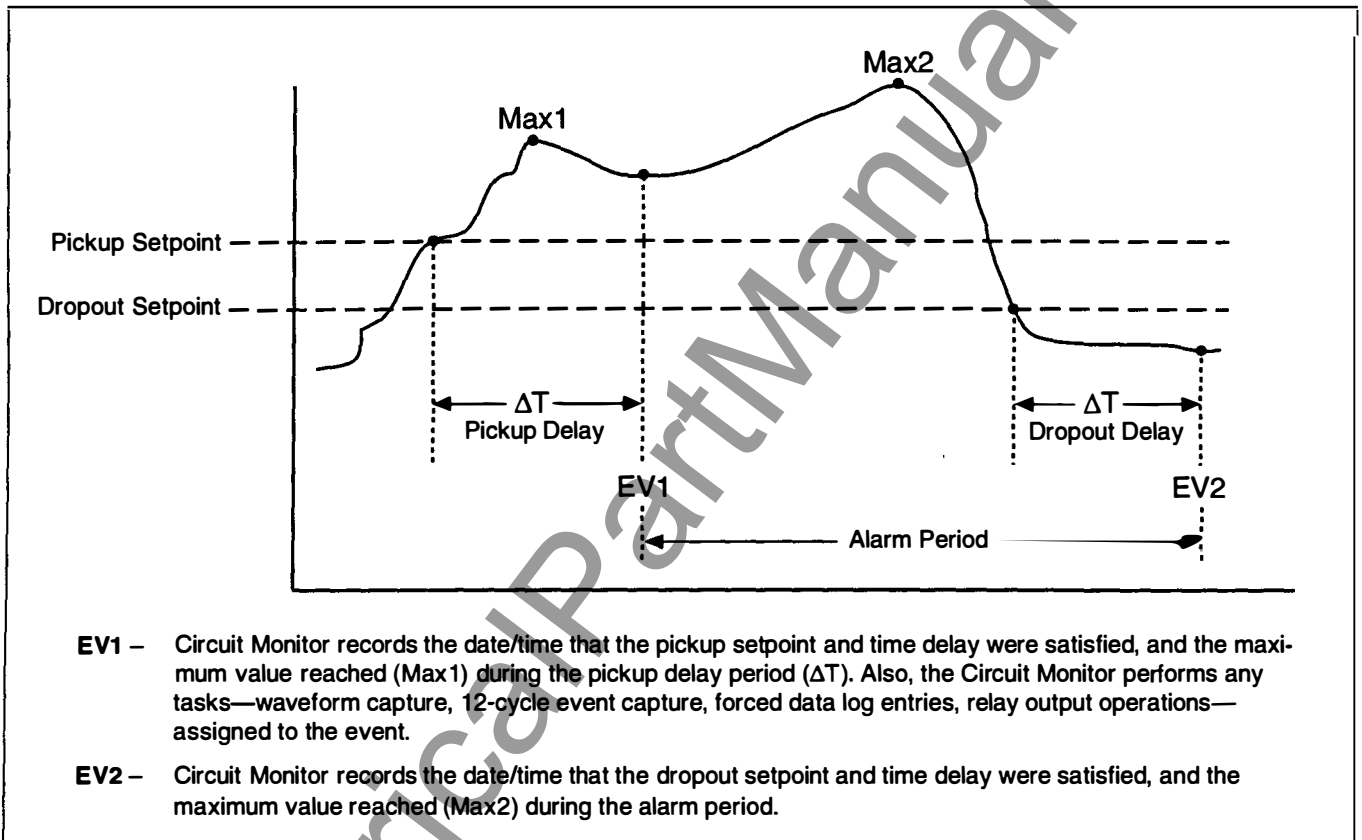

Figure 7-2: How the Circuit Monitor handles setpoint-driven alarms

PROTECTIVE FUNCTIONS

A Circuit Monitor—model CM-2150 (or higher) equipped with an I/O module—can mimic the functions of certain motor protective devices such as phase loss, undervoltage, or reverse phase relays. While the Circuit Monitor is not a primary protective device, it can detect abnormal conditions and respond by operating one or more form-C output contacts. These outputs can be used to operate an alarm horn or bell to annunciate the alarm condition.

Note: The Circuit Monitor is not designed for use as a protective relay. While its protective functions may be acceptable for certain applications, it should not be considered a substitute for proper circuit protection.

If the user determines that the Circuit Monitor's performance is acceptable, the output contacts can be used to mimic the functions of a protective device. When deciding if the Circuit Monitor is acceptable for these applications, keep the following points in mind:

- Circuit Monitors require control power in order to operate properly.
- Circuit Monitors may take up to 5 seconds after control power is applied before protective functions are activated. If this is too long, a reliable source of control power is required.
- When control power is interrupted for more than approximately 100 milliseconds, the Circuit Monitor releases all energized output contacts.
- Standard protective functions may take 2-3 seconds to operate, even if no delay is intended.
- A password is required to program the Circuit Monitor's protective functions.

A description of the most common protective functions follows. For detailed instructions on setting up protective functions from the Circuit Monitor's front panel, see **Setting Up Alarm/Relay Functions** in Chapter 4, and **Appendix I—Alarm Setup Information**.

Under Voltage:

- Pickup and dropout setpoints are entered in volts.
- The under voltage alarm occurs when any phase voltage is equal to or below the pickup setpoint long enough to satisfy the specified pickup delay (in seconds).
- When the under voltage alarm occurs, the Circuit Monitor operates any specified relays.
- Relays configured for normal mode operation remain closed until the under voltage alarm clears. The under voltage alarm clears when *all* of the phases remain above the dropout setpoint for the specified dropout delay period.
- To release any relays that are in latched mode, enter the Circuit Monitor's Alarm mode and select the clear option. For detailed instructions, see **Clearing the Priority 1 Log** in Chapter 4.

Protective Functions (cont.) Over Voltage:

- Pickup and dropout setpoints are entered in volts.
- The over voltage alarm occurs when any phase voltage is equal to or above the pickup setpoint long enough to satisfy the specified pickup delay (in seconds).
- When the over voltage alarm occurs, the Circuit Monitor operates any specified relays.
- Relays configured for normal mode operation remain closed until the over voltage alarm clears. The over voltage alarm clears when *all* of the phases remain below the dropout setpoint for the specified dropout delay period.
- To release any relays that are in latched mode, enter the Circuit Monitor's Alarm mode and select the *Clear* option. For detailed instructions, see **Clearing the Priority 1 Log** in Chapter 4.

Unbalance Current:

- Pickup and dropout setpoints are entered in tenths of percent, based on the percentage difference between each phase current with respect to the average of all phase currents. For example, enter an unbalance of 16.0% as 160.
- The unbalance current alarm occurs when any phase current deviates from the average of the phase currents, by the percentage pickup setpoint, for the specified pickup delay (in seconds).
- When the unbalance current alarm occurs, the Circuit Monitor operates any specified relays.
- Relays configured for normal mode operation remain closed until the unbalance current alarm clears. The unbalance current alarm clears when the percentage difference between each phase and the average of all phases remains below the dropout setpoint for the specified dropout delay period.
- To release any relays that are in latched mode, enter the Circuit Monitor's Alarm mode and select the *Clear* option. For detailed instructions, see **Clearing the Priority 1 Log** in Chapter 4.

Unbalance Voltage:

- Pickup and dropout setpoints are entered in tenths of percent, based on the percentage difference between each phase voltage with respect to the average of all phase voltages. For example, enter an unbalance of 16.0% as 160.
- The unbalance voltage alarm occurs when any phase voltage deviates from the average of the phase voltages, by the percentage pickup setpoint, for the specified pickup delay (in seconds).

- Protective Functions (cont.)**
- When the unbalance voltage alarm occurs, the Circuit Monitor operates any specified relays.
 - Relays configured for normal mode operation remain closed until the unbalance voltage alarm clears. The unbalance voltage alarm clears when the percentage difference between each phase and the average of all phases remains below the dropout setpoint for the specified dropout delay (in seconds).
 - To release any relays that are in latched mode, enter the Circuit Monitor's Alarm mode and select the *Clear* option. For detailed instructions, see **Clearing the Priority 1 Log in Chapter 4**.

Phase Loss—Current:

- Pickup and dropout setpoints are entered in tenths of percent, based on a percentage ratio of the smallest current to the largest current. For example, enter 50% as 500.
- The phase loss current alarm occurs when any current value is equal to or below the pickup setpoint for the specified pickup delay (in seconds).
- When the phase loss current alarm occurs, the Circuit Monitor operates any specified relays.
- Relays configured for normal mode operation remain closed until the phase loss current alarm clears. The phase loss current alarm clears when the ratio of the smallest current to the largest current remains above the dropout setpoint for the specified dropout delay (in seconds).
- To release any relays that are in latched mode, enter the Circuit Monitor's Alarm mode and select the *Clear* option. For detailed instructions, see **Clearing the Priority 1 Log in Chapter 4**.

Phase Loss—Voltage:

- Pickup and dropout setpoints are entered in volts.
- The phase loss voltage alarm occurs when any voltage value is equal to or below the pickup setpoint for the specified pickup delay (in seconds).
- When the phase loss voltage alarm occurs, the Circuit Monitor operates any specified relays.
- Relays configured for normal mode operation remain closed until the phase loss voltage alarm clears. The alarm clears when one of the following is true:
 - *all* of the phases remain above the dropout setpoint for the specified dropout delay (in seconds), OR
 - *all* of the phases drop below the phase loss pickup setpoint.
- If *all* of the phase voltages are equal to or below the pickup setpoint, during the pickup delay, the phase loss alarm will not activate. This is considered an under voltage condition. It should be handled by configuring the under voltage protective functions.

- Protective Functions (cont.)**
- To release any relays that are in latched mode, enter the Circuit Monitor's Alarm mode and select the *Clear* option. For detailed instructions, see **Clearing the Priority 1 Log** in Chapter 4.

Reverse Power:

- Pickup and dropout setpoints are entered in kilowatts.
- The reverse power alarm occurs when the 3-phase power flow in the negative direction remains at or below the negative pickup value for the specified pickup delay (in seconds).
- When the reverse power alarm occurs, the Circuit Monitor operates any specified relays.
- Relays configured for normal mode operation remain closed until the reverse power alarm clears. The alarm clears when the 3-phase power reading remains above the dropout setpoint for the specified dropout delay (in seconds).
- To release any relays that are in latched mode, enter the Circuit Monitor's Alarm mode and select the *Clear* option. For detailed instructions, see **Clearing the Priority 1 Log** in Chapter 4.

Phase Reversal:

- Pickup and dropout setpoints and delays do not apply to phase reversal.
- The phase reversal alarm occurs when the phase voltage waveform rotation differs from the default phase rotation. The Circuit Monitor assumes that an ABC phase rotation is normal. If a CBA phase rotation is normal, the user must change the Circuit Monitor's phase rotation from ABC (default) to CBA.
- When the phase reversal alarm occurs, the Circuit Monitor operates any specified relays.
- Relays configured for normal mode operation remain closed until the phase reversal alarm clears.
- To release any relays that are in latched mode, enter the Circuit Monitor's Alarm mode and select the *Clear* option. For detailed instructions, see **Clearing the Priority 1 Log** in Chapter 4.

CHAPTER 8—LOGGING

CHAPTER CONTENTS

Event Logging	84
Event Log Storage	84
Data Logging	85
Alarm Driven Data Log Entries	85
Organizing Data Log Files	85
Storage Considerations	86
Maintenance Log	87

EVENT LOGGING

The Circuit Monitor provides an event log file to record the occurrence of important events. The Circuit Monitor can be configured to log the occurrence of any alarm condition as an event. The event log can be configured as *first-in-first-out (FIFO)* or *fill and hold*. Using POWERLOGIC application software, the Circuit Monitor's event log memory can be cleared, and the event log can be uploaded for viewing and saved to disk.

Event Log Storage

Circuit Monitor models 2150 and higher provide nonvolatile memory for event log storage. The size of the event log (the maximum number of events) is user-definable. When determining the maximum number of events, take the Circuit Monitor's total storage capacity into consideration. For Circuit Monitor models 2150 and 2250, the total storage capacity must be allocated between the event log and up to 14 data logs. For Circuit Monitor models 2350 and higher, the total data storage capacity must be allocated between an event log, a 4-cycle waveform capture log, a 12-cycle event capture log, and up to 14 data logs. See **Memory Allocation** in **Chapter 12** for additional memory considerations.

DATA LOGGING

Circuit Monitor models CM-2150 and higher are equipped with nonvolatile memory for storing meter readings at regular intervals. The user can configure up to 14 independent data log files. The following items can be configured for each data log file:

- Logging Interval—1 minute to 24 hours
- Offset Time
- First-In-First-Out (FIFO) or Fill & Hold
- Values to be logged—up to 100, including date/time of last log entry

Each data log file can be cleared, independently of the others, using POWERLOGIC application software. For instructions on setting up and clearing data log files, refer to the POWERLOGIC application software instruction bulletin.

Alarm-Driven Data Log Entries

The Circuit Monitor can detect over 100 alarm conditions, including over under conditions, status input changes, phase unbalance conditions, and more. (See Chapter 7—Alarm Functions for more information.) Each alarm condition can be assigned one or more tasks, including forced data log entries into any or all data log files.

For example, assume that you've defined 14 data log files. Using POWERLOGIC software, you could select an alarm condition such as "Overcurrent Phase A" and set up the Circuit Monitor to force data log entries into any of the 14 log files each time the alarm condition occurs.

Organizing Data Log Files

There are many ways to organize data log files. One possible way is to organize log files according to the logging interval. You might also define a log file for entries forced by alarm conditions. For example, you could set up four data log files as follows:

- Data Log 1:** Voltage *logged every minute*. File is large enough to hold 60 entries so that you could look back over the last hour's voltage readings.
- Data Log 2:** Voltage, current, and power *logged hourly* for a historical record over a longer period.
- Data Log 3:** Energy *logged once daily*. File is large enough to hold 31 entries so that you could look back over the last month and see daily energy use.
- Data Log 4:** Report by exception file. File contains data log entries that are forced by the occurrence of an alarm condition. See **Alarm-Driven Data Log Entries** above. **Note:** The same data log file can support both scheduled and alarm driven entries.

Storage Considerations

The following are important storage considerations:

- Circuit Monitor model CM-2150 or higher is required for on-board data logging.
- For Circuit Monitor models CM-2150 and CM-2250, the total storage capacity must be allocated between the event log and up to 14 data logs. For Circuit Monitor models 2350 and higher, the total data storage capacity must be allocated between an event log, a 4-cycle waveform capture log, a 12-cycle event capture log, and up to 14 data logs.
- Circuit Monitor models CM-2150 and CM-2250 store up to 6,144 logged values. Models CM-2350 and higher store up to 51,200 values. (These numbers assume that you've devoted all of the Circuit Monitor's logging memory to data logging.)
- Each defined data log file stores a date and time. To minimize storage space occupied by dates/times, use a few log files that log many values, as opposed to many log files that store only a few values each.
- See **Memory Allocation in Chapter 12** for additional storage considerations.

MAINTENANCE LOG

The Circuit Monitor stores a maintenance log in nonvolatile memory. This log contains several values that are useful for maintenance purposes. Table 8-1 below lists the values stored in the maintenance log and a short description of each. The values stored in the maintenance log are cumulative over the life of the Circuit Monitor and cannot be reset.

You can view the maintenance log using POWERLOGIC application software. For specific instructions, refer to the POWERLOGIC software instruction bulletin.

Table 8-1
Values Stored in Maintenance Log

Value Stored	Description
Number of Demand Resets	Number of times demand values have been reset.
Number of Energy Resets	Number of times energy values have been reset.
Number of Min/Max Resets	Number of times min/max values have been reset.
Number of Output Operations	Number of times relay output has operated. This value is stored for each relay output.
Number of Power Losses	Number of times Circuit Monitor has lost control power.
Number of Firmware Downloads	Number of times new firmware has been downloaded to the Circuit Monitor over communications.
Number of Optical Comms Sessions	Number of times the front panel optical communications port has been used.
Highest Temperature Monitored	Highest temperature reached inside the Circuit Monitor.
Lowest Temperature Monitored	Lowest temperature reached inside the Circuit Monitor.

CHAPTER 9—WAVEFORM CAPTURE

CHAPTER CONTENTS

4-Cycle Waveform Capture	88
Manual Waveform Capture	88
Automatic Waveform Capture	88
Waveform Storage	90
12-Cycle Event Capture	91
Manual Event Capture	91
Automatic Event Capture—High-Speed Trigger	91
Automatic Event Capture—Setpoint-Controlled	93
12-Cycle Event Capture Storage	94

4-CYCLE WAVEFORM CAPTURE

Circuit Monitor models CM-2250 and higher are equipped with waveform capture. Circuit Monitors use a sophisticated, high-speed sampling technique to sample 64 times per cycle, simultaneously, on all current and voltage inputs.

There are two ways to initiate a waveform capture:

- Manually, from a remote personal computer, using POWERLOGIC application software
- Automatically, by the Circuit Monitor, when an alarm condition such as “THD setpoint exceeded” occurs

Both methods are described below.

Manual Waveform Capture

Using POWERLOGIC application software, you can initiate a manual waveform capture from a remote personal computer. To initiate a manual waveform capture, select a Circuit Monitor equipped with waveform capture and issue the capture command. The Circuit Monitor captures the waveform, and the software retrieves and displays it.

POWERLOGIC software lets you view all phase voltage and current waveforms simultaneously, or zoom in on a single waveform that includes a data block with extensive harmonic data.

For instructions on performing manual waveform capture using POWERLOGIC software, refer to the application software instruction manual.

Automatic Waveform Capture

The Circuit Monitor can detect over 100 alarm conditions—such as metering setpoint exceeded and status input changes (see **Chapter 7—Alarm Functions** for more information). The Circuit Monitor can be set up to automatically capture and save the four cycles of waveform data associated with an alarm condition.

Setting Up the Circuit Monitor

The Circuit Monitor must be set up for automatic waveform capture using POWERLOGIC application software. To set up the Circuit Monitor for automatic waveform capture, perform the following steps:

1. Select an alarm condition. (See **Appendix I** for a listing of alarm conditions.)
2. Define the setpoints, if necessary. (This may not be necessary if the selected event is a status input change, for example.)
3. Specify the alarm condition for automatic waveform capture.

Repeat these steps for the desired alarm conditions. For specific instructions on selecting alarm conditions and specifying them for automatic waveform capture, refer to the POWERLOGIC application software instruction manual.

How it Works

At the beginning of every update cycle, the Circuit Monitor acquires four cycles of sample data for metering calculations (see figure 9-1). During the update cycle, the Circuit Monitor performs metering calculations and checks for alarm conditions. If the Circuit Monitor sees an alarm condition, it performs any actions assigned to the alarm condition. These actions can include automatic waveform capture, forced data logs, or output relay operations. For this example, assume that automatic waveform capture has been assigned to the alarm condition. When the Circuit Monitor sees that an alarm condition specified for automatic waveform capture has occurred, it stores the four cycles of waveform data acquired at the beginning of the update cycle.

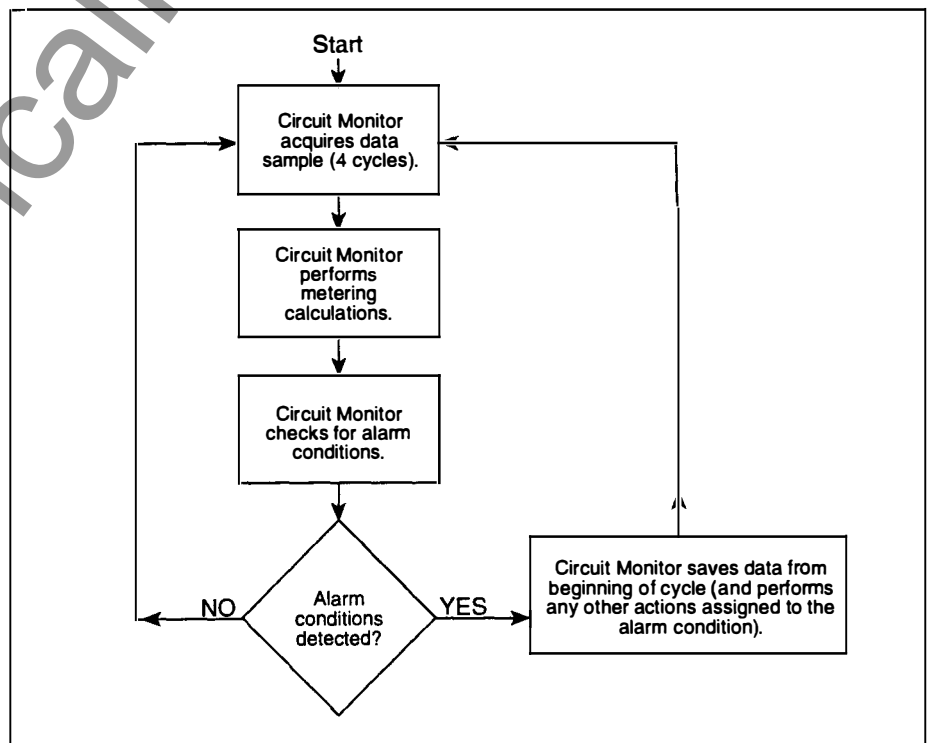

Figure 9-1: Flowchart illustrating automatic waveform capture

Waveform Storage

Circuit Monitor model 2250 stores waveforms differently than models 2350 and higher. The lists below describe how each model stores waveforms.

CM-2250

- Can store only one captured waveform. Each new waveform capture (either manual or automatic) replaces the last waveform data.
- Stores the captured waveform in volatile memory—the waveform data is lost on power-loss.
- The captured waveform does not affect event log and data log storage space. The captured waveform is stored separately.

CM-2350 (and higher)

- Can store multiple captured waveforms.
- Stores the captured waveforms in nonvolatile memory—the waveform data is retained on power-loss.
- The number of waveforms that can be stored is based on the amount of memory that has been allocated to waveform capture. See **Memory Allocation** in Chapter 12.

12-CYCLE EVENT CAPTURE Circuit Monitor models CM-2250 and higher are equipped with a feature called 12-cycle event capture. By connecting the Circuit Monitor to an external, high-speed relay, the Circuit Monitor can capture and provide valuable information on short duration events such as voltage sags and swells.

Each event capture includes 12 cycles of sample data from each voltage and current input. An adjustable trigger delay lets the user adjust the number of pre-event/post-event cycles.

There are three ways to initiate a 12-cycle event capture:

- Manually, from a remote personal computer using POWERLOGIC application software
- Automatically, using an external, high-speed relay to trigger the Circuit Monitor
- Automatically, by the Circuit Monitor, when an alarm condition such as "THD setpoint exceeded" occurs

These methods are described below.

Manual Event Capture

Using POWERLOGIC application software, you can initiate a manual 12-cycle event capture from a remote personal computer. Manual event captures can store 12 cycles of data for steady-state analysis.

To initiate a manual capture, select a Circuit Monitor equipped with 12-cycle event capture and issue the capture command. The Circuit Monitor captures the data, and the software retrieves and displays it. POWERLOGIC software lets you view all 12-cycle phase voltage and current waveforms simultaneously, or zoom in on a single 12-cycle waveform.

For instructions on performing manual 12-cycle event capture using POWERLOGIC software, refer to the application software instruction manual.

Automatic Event Capture— High Speed Trigger

By connecting the Circuit Monitor to an external, high-speed relay, the Circuit Monitor can capture and provide valuable information on short duration events such as voltage sags and swells. (The Circuit Monitor must be equipped with an I/O module.) Figure 9-2 on page 92 shows a block diagram that illustrates the relay-to-Circuit Monitor connections. As shown in figure 9-2, the relay must be wired to status input S2. Status input S2 is a high-speed input designed for this application.

12-Cycle Event Capture Storage

Circuit Monitor model 2250 stores 12-cycle event capture differently than models 2350 and higher. The lists below describe how each model stores 12-cycle event captures.

CM-2250:

- Stores only one captured 12-cycle event. Each new event capture (either manual or automatic) replaces the last captured data.
- Stores the captured data in volatile memory—the data is lost on power-loss.
- The captured data does not affect event log and data log storage space. The captured waveform is stored separately.

CM-2350 (and higher):

- Stores multiple captured 12-cycle events.
- Stores the captured data in nonvolatile memory—the data is retained on power-loss.
- The number of 12-cycle event captures that can be stored is based on the amount of memory that has been allocated to 12-cycle event capture. See **Memory Allocation** in Chapter 12.

CHAPTER 10—DISTURBANCE MONITORING

Chapter 9—Waveform Capture describes the use of Circuit Monitor Models 2250 and higher to record 12 cycles of data simultaneously on all channels, when triggered by an external device such as an undervoltage relay. This chapter describes the use of Circuit Monitor Models 2350 and higher to monitor continuously for disturbances on the current and voltage inputs to the Circuit Monitor.

The CM-2350 can perform continuous monitoring of RMS magnitudes of any of the metered channels of current and voltage. These calculations can be used to detect sags or swells on these channels. The Circuit Monitor calculates RMS magnitudes, based on 16 data points per cycle, every 1/2 cycle. This insures that even single cycle duration RMS variations are not missed. When the Circuit Monitor detects a sag or swell, it can perform the following actions:

- The event log can be updated with a sag/swell pickup event entry, time stamped with 1 millisecond resolution.
- An RMS magnitude corresponding to the magnitude of the sag or swell disturbance event can be stored in the event log.
- A 12 Cycle event capture of the disturbance can be recorded. The event capture includes 12 cycles of data with a resolution of 64 data points per cycle on all metered currents and voltages
- A forced data log entry can be made in up to 14 independent data logs.
- Any of the optional output relays can be operated upon detection of the event.
- At the end of the disturbance, a dropout time stamp can be entered in the event log with 1 millisecond resolution.
- A second RMS magnitude corresponding to the magnitude of the sag or swell can be stored in the Event Log.
- The front panel can indicate, by a flashing Alarm LED, that a sag or swell event has occurred. A list of up to 10 of the prior alarm codes can be viewed in the P1 Log from the Circuit Monitor's front panel.

In addition to these features, the CM-2350 model includes expanded non-volatile memory for logging of up to eight 12-cycle event captures. These recordings each have a resolution of 64 data points per cycle, and they each include simultaneously acquired data from all of the metering input channels. Using POWERLOGIC application software, the user can choose how to allocate the nonvolatile memory among the 14 data logs, the event log, multiple 4-cycle waveform captures and multiple 12-cycle event captures as described above.

As explained in chapter 9, the 12-cycle event capture has a user-programmable number of pre-event cycles ranging from 2 to 10 cycles. This allows the user to tailor the 12-cycle event capture for more or less pre-event data.

POWERLOGIC Application Software can be used to setup each of the sag/swell alarms. For each alarm, the user programs the following data:

- Sag/swell alarm priority
- Pickup setpoint in amps or volts
- Pickup delay in cycles
- Dropout setpoint in amps or volts
- Dropout delay in cycles
- Data and waveform logging instructions
- Relay output actions

POWERLOGIC application software can be used to retrieve the above information for later analysis. Figure 10-1 shows a typical distribution feeder sag as recorded by the CM-2350, and displayed using System Manager Software.

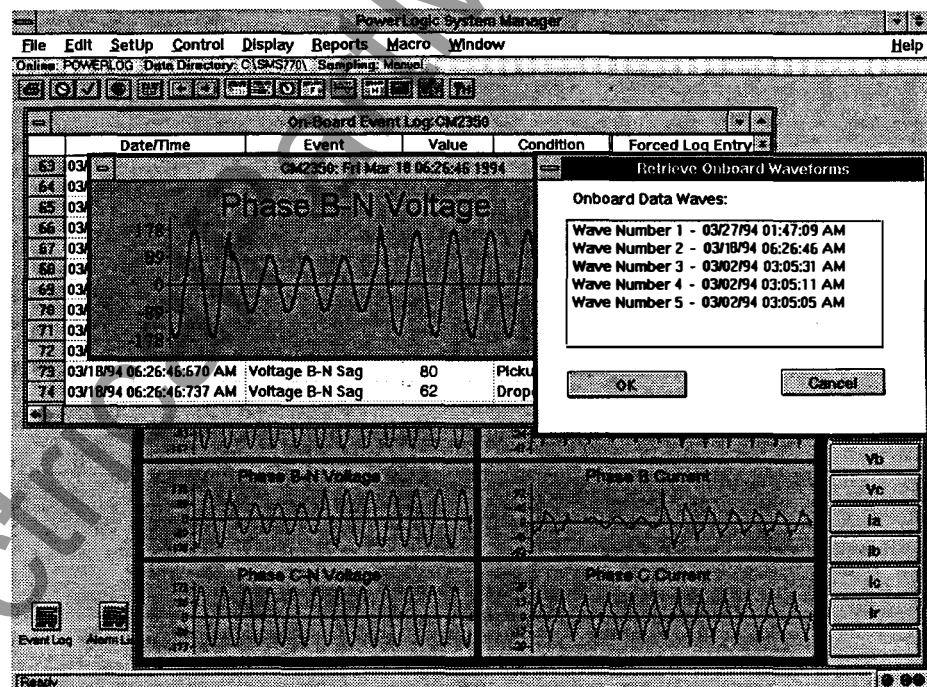

Figure 10-1: Sag recorded by the CM-2350.

CHAPTER 11—MAINTENANCE AND TROUBLESHOOTING

MAINTENANCE

The Circuit Monitor does not require regular maintenance, nor does it contain any user-serviceable parts. If the Circuit Monitor requires service, contact your local Square D sales representative, or call the POWERLOGIC Technical Support Center for assistance. See **Getting Technical Support** in this chapter. *Do not open the Circuit Monitor. Opening the Circuit Monitor may void the warranty.*

Battery-Backed RAM

The Circuit Monitor uses battery-backed nonvolatile RAM to retain all data except calibration constants. Calibration constants are stored in nonvolatile EEPROM, which requires no battery. The Circuit Monitor's battery-backed RAM lasts many decades under typical operating conditions. The battery-backed RAM is activated when the Circuit Monitor is manufactured. With no control power applied to the Circuit Monitor, the battery can back up RAM for a continuous period of 7 years at 70° C. Once control power is applied, the RAM battery is no longer under load. Under no load, the life of the battery-backed RAM is 100 years at 55° C continuous, 40 years at 60° C continuous, and 10 years at 70° C continuous. Should the RAM ever need replacement, contact your Square D representative.

DANGER

HAZARD OF ELECTRIC SHOCK.

Do not attempt to service the Circuit Monitor. CT and PT inputs may contain hazardous currents and voltages. Only authorized Square D service personnel should service the Circuit Monitor.

Failure to observe this precaution will result in severe personal injury or death!

CAUTION

HAZARD OF EQUIPMENT DAMAGE.

Dielectric (Hi-Pot) testing of the Circuit Monitor may damage the unit. Do not Hi-Pot. Before Hi-Pot testing any equipment in which the Circuit Monitor is installed, disconnect all input and output wires to the Circuit Monitor.

Failure to observe this precaution could result in equipment damage.

TROUBLESHOOTING

This section describes three potential problems, their possible causes, and checks and/or cure for each. If, after completing the listed checks, you cannot solve the problem, contact the POWERLOGIC Technical Support Center for assistance. See **Getting Technical Support** on the following page.

PROBLEM: After applying control power to the Circuit Monitor, the display is still blank.

Possible Cause: The Circuit Monitor is not receiving the necessary power.

Check or Cure: Verify that Circuit Monitor L and N terminals (terminals 25 and 27) are receiving the necessary power. If you are using an optional voltage/power module, check to see that the module is properly installed on the Circuit Monitor. See **Appendix C—Installing the Optional Voltage/Power Module**.

PROBLEM: The data being displayed is inaccurate or not what you expect.

Possible Cause: Incorrect setup values.

Check or Cure: Check to see that the correct values have been entered for Circuit Monitor setup parameters (CT and PT ratings, System Type, Nominal Frequency, and so on). See **Configuring the Circuit Monitor in Chapter 4** for setup instructions.

Possible Cause: Circuit Monitor is wired improperly.

Check or Cure: Check that CTs and PTs are connected correctly (proper polarity observed) and energized. Check shorting terminals. See **Wiring CTs, PTs, and Control Power in Chapter 3** for wiring diagrams.

Possible Cause: Incorrect voltage inputs.

Check or Cure: Check Circuit Monitor voltage input terminals (terminals 9, 10, 11,12) to verify that adequate voltage is present.

Possible Cause: Circuit Monitor is grounded incorrectly.

Check or Cure: Verify that the Circuit Monitor is grounded as described in **Grounding the Circuit Monitor in Chapter 3**.

Troubleshooting (cont.)

PROBLEM: Cannot communicate with Circuit Monitor from a remote personal computer.

Possible Cause: Circuit Monitor address is incorrect.

Check or Cure: Check to see that the Circuit Monitor is correctly addressed. See **Setting the Device Address** in Chapter 4 for instructions.

Possible Cause: Circuit Monitor baud rate is incorrect.

Check or Cure: Verify that the baud rate of the Circuit Monitor matches the baud rate of all other devices on its communications link. See **Setting the Baud Rate** in Chapter 4 for instructions.

Possible Cause: Communications lines are improperly biased.

Check or Cure: Check to see that a multipoint communications adapter is being properly used to bias the communication lines. See **Biasing the Communications Link** in Chapter 3 for instructions.

Possible Cause: Communications lines are improperly terminated.

Check or Cure: Check to see that a multipoint communications terminator is properly installed. See **Terminating the Communications Link** in Chapter 3 for instructions.

Possible Cause: Incorrect route statement to Circuit Monitor.

Check or Cure: Check route statement. Refer to the software instruction bulletin for instructions on defining route statements.

GETTING TECHNICAL SUPPORT

POWERLOGIC customers can receive technical support by contacting the POWERLOGIC Technical Support Center, in one of two ways:

- **Fax your request for support to (615) 459-4294**, 24 hours a day, seven days a week. Be sure to include your name and company, address, phone number, type(s) of POWERLOGIC product(s), and a detailed description of your problem. The support center will normally respond within two business hours. Business hours are 7:30 A.M. to 4:30 P.M., Central Time, Monday through Friday—except holidays.
- **Phone (615) 459-8552**, 7:30 A.M. to 4:30 P.M., Central Time, Monday through Friday (except holidays) for assistance from a technical support specialist. If a technical support specialist is not available, leave a voice mail message or, in an urgent situation, speak to an operator who will process your request. The support center will normally respond within two business hours.

CHAPTER 12—ADVANCED TOPICS

CHAPTER CONTENTS

The Command Interface	101
Command Codes	101
Operating Relays Using the Command Interface	103
Setting Up Relays for Remote (External) Control	103
Energizing Relays	103
De-Energizing Relays	103
Setting Up Relays for Circuit Monitor (Internal) Control	104
Overriding an Output Relay	104
Releasing an Overridden Relay	105
Setting Scale Factors For Extended Metering Ranges	106
Setting The Date and Time Using the Command Interface	109
Memory Allocation	110
Memory Example	112
How Power Factor is Stored	112
Changing the VAR/Power Factor Sign Convention	113
Conditional Energy	114
Command Interface Control	114
Status Input Control	115
Incremental Energy	115
Using Incremental Energy	116
Changing the Demand Calculation Method	117
Changing to the Block/Rolling Method	117
Setting Up a Demand Synch Pulse Input	117
Controlling the Demand Interval Over the Communications Link.....	118

THE COMMAND INTERFACE The Circuit Monitor provides a command interface that can be used to perform various operations such as manual relay operation.

To use the command interface, do the following:

1. Write related parameters to the command parameter registers—#7701–7709. (Some commands require no parameters. For these commands, write the command code only to register 7700.)
2. Write a command code to the Circuit Monitor's command interface register—#7700.

Command Codes

The following is a listing of command codes that can be written to the command interface register (7700) and to the command interface parameter registers (7701–7709).

<u>Code</u>	<u>Parameter(s)</u>	<u>Description</u>	<u>Reset Req'd</u>
1110	None	Resets the Circuit Monitor.	N/A
2110	Scale Factors A–E	Change scale factors A–E and reset min/max registers/file. Then reset unit.	N
2120	CT ratio correction factors A,B,C,N	Change CT ratio correction factors	Y
2130	PT ratio correction factors A,B,C	Change PT ratio correction factors	Y
2310	Unit Address	Change unit's address to the address specified and reset unit	N
2320	Baud Rate	Change unit's baud rate to the baud rate specified and reset unit	N
2330	None	Enable unit #01's response to the SY/MAX enquire transmission (default)	N
2331	None	Disable unit #01's response to the SY/MAX enquire transmission	N
2340	None	Set control of conditional energy to status inputs (default)	N
2341	None	Set control of conditional energy to command interface	N
2350	None	Enable front panel comm port (default)	N
2351	None	Disable front panel comm port	N
2360	None	Enable front panel setup (default)	N
2361	None	Disable front panel setup	N
3310	Bit Map Relay Designation	Place specified relays under external control (default)	N
3311	Bit Map Relay Designation	Place specified relays under internal control	N
3320	Bit Map Relay Designation	De-energize designated relays per specified bit map	N
3321	Bit Map Relay Designation	Energize designated relays per specified bit map	N
3340	Bit Map Output Designation	Release specified relays from override control	N
3341	Bit Map Output Designation	Place specified relays under override control.	N

<u>Code</u>	<u>Parameter(s)</u>	<u>Description</u>	<u>Reset Req'd</u>
3390	Bit Map Input Designation	Set control of conditional energy to indicated status inputs.	N
4110	None	Reset Min/Max	N
4310	None	Set VAr/PF sign convention to CM1 convention (default)	Y
4311	None	Set VAr/PF sign convention to alternate convention	Y
4910	None	Trigger 4-cycle waveform capture	N
4911	None	Trigger 12-cycle waveform capture	N
4920	Bit Map	Trigger Data Log Entry	N
5110	None	Reset Peak Demand Currents/K Factors	N
5120	None	Reset Peak Demand Powers and associated average Power Factors	N
5310	None	Set power demand method to thermal (default)	Y
5311	None	Set power demand method to block/rolling	Y
5320	None	Set external demand synch source to input 1	N
5321	None	Set external demand synch source to the command interface	N
5910	None	Start new demand interval	N
6210	None	Clear all accumulated energies	N
6220	None	Clear all conditional energies	N
6310	None	Set energy accumulation method to absolute	N
6311	None	Set energy accumulation method to signed	N
6320	None	Disable conditional energy accumulation	N
6321	None	Enable conditional energy accumulation	N
6330	None	Set reactive energy and demand method to include only the fundamental component	N
6331	None	Set reactive energy and demand method to include the both fundamental and harmonic components	N
6910	None	Start new incremental energy interval	N

Command Result Codes

Note: Command Result codes should match the SY/MAX error codes whenever possible.

<u>Result Condition</u>	<u>Result Code (Hex)</u>
Successful commands	00
Undefined commands	81
Commands with undefined or illegal parameters	82
Protected mode not enabled	200
Time-out, operation not performed	201
Invalid password, operation not performed	202

OPERATING RELAYS USING THE COMMAND INTERFACE

By writing commands to the command interface, you can control Circuit Monitor relay outputs. This section tells how to operate the relay outputs. See Appendix E, registers 2500-2521, for information on relay output configuration.

Setting Up Relays for Remote (External) Control

To set up the Circuit Monitor for remote (external) relay operation, you must configure the Circuit Monitor for remote relay control.

To configure the Circuit Monitor for remote relay control:

1. Write a bitmap (see below) to the command parameter register, specifying the relays to be setup for remote control.

<u>Reg #</u>	<u>Value</u>	<u>Description</u>
7701	Bitmap	Bitmap corresponding to relays to be placed under manual control. Bit 1 corresponds to KYZ, Bit 2 corresponds to Relay 1, Bit 3 corresponds to relay 2, Bit 4 corresponds to relay 3.
7700	3310	Command code to configure relay for remote (external) control

2. Write a command code (3310) to the Circuit Monitor's command interface register (7700).

Energizing a Relay

To energize a relay, do the following:

1. Write a bitmap (see below) to the command parameter register, specifying the relays to be energized.

<u>Reg #</u>	<u>Value</u>	<u>Description</u>
7701	Bitmap	bitmap corresponding to relays to be energized. Bit 1 corresponds to KYZ, Bit 2 corresponds to Relay 1, Bit 3 corresponds to relay 2, Bit 4 corresponds to relay 3.
7700	3321	Command code to energize relay

2. Write a command code (3321) to the Circuit Monitor's command interface register (7700).

De-energizing a Relay

To de-energize a relay, do the following:

1. Write a bitmap (see below) to the command parameter register, specifying the relays to be de-energized.

<u>Reg #</u>	<u>Value</u>	<u>Description</u>
7701	Bitmap	bitmap corresponding to relays to be de-energized. Bit 1 corresponds to KYZ, Bit 2 corresponds to Relay 1, Bit 3 corresponds to relay 2, Bit 4 corresponds to relay 3.
7700	3320	Command code to de-energize relay

2. Write a command code (3320) to the Circuit Monitor's command interface register (7700).

Setting Up Relays for Circuit Monitor (Internal) Control

For the Circuit Monitor to automatically control relays based on alarm conditions or as a pulse initiator output, you must configure the relays for Circuit Monitor (internal) control.

To configure relays for Circuit Monitor (internal) control, do the following:

1. Write a bitmap (see below) to the command parameter register, specifying the relays to be setup for internal control.

<u>Reg #</u>	<u>Value</u>	<u>Description</u>
7701	Bitmap	Bitmap corresponding to relays to be placed under internal control. Bit 1 corresponds to KYZ, Bit 2 corresponds to Relay 1, Bit 3 corresponds to relay 2, Bit 4 corresponds to relay 3.
7700	3311	Command code to configure relay for internal control

2. Write a command code (3311) to the Circuit Monitor's command interface register (7700).

Overriding an Output Relay

It is possible to override a circuit monitor output relay set up for Circuit Monitor (internal) control. Once overridden, the specified relays will respond to manual control.

To override relays, do the following:

1. Write a bitmap (see below) to the command parameter register, specifying the relays to be overridden.

<u>Reg #</u>	<u>Value</u>	<u>Description</u>
7701	Bitmap	Bitmap corresponding to relays to be placed under override control. Bit 1 corresponds to KYZ, Bit 2 corresponds to Relay 1, Bit 3 corresponds to relay 2, Bit 4 corresponds to relay 3.
7700	3341	Command Code to place relay under override control.

2. Write a command code (3341) to the Circuit Monitor's command interface register (7700).

Releasing an Over-Ridden Relay

To return an overridden relay to Circuit Monitor (internal) control, you must release the override.

To release the override, do the following:

1. Write a bitmap (see below) to the command parameter register, specifying the relays to be released from override.

Reg #	Value	Description
7701	Bitmap	Bitmap corresponding to relays to be released from override control. Bit 1 corresponds to KYZ, Bit 2 corresponds to Relay 1, Bit 3 corresponds to relay 2, Bit 4 corresponds to relay 3.
7700	3340	Command Code to release overridden relays.

2. Write a command code (3340) to the Circuit Monitor's command interface register (7700).

**SETTING SCALE FACTORS
FOR EXTENDED
METERING RANGES**

The Circuit Monitor stores instantaneous metering data in single registers. Each register has a maximum range of 32,767. In order to meter extended ranges, or to get additional resolution on small loads, current, voltage, and power readings can accommodate multipliers other than one. Multipliers can be changed from the default value of 1 to other values such as .01, .1, 10, 100, or 1000.

The Circuit Monitor stores these multipliers as scale factors. A scale factor is the multiplier expressed as a power of 10. For example, a multiplier of 10 is represented as a scale factor of 1, since $10^1=10$; a multiplier of 100 is represented as a scale factor of 2, since $10^2=100$.

If the Circuit Monitor displays "-OFLO-" for any reading, the scale factor should be changed to bring the reading back into range. For example, since a Circuit Monitor register cannot store a number as large as 138,000, a 138kV system requires a multiplier of 10. 138,000 should be converted to $13,800 \times 10$. The Circuit Monitor would store this value as 13,800 with a scale factor of 1 (since $10^1=10$). The Circuit Monitor front panel would display the value as 138.00 with the KILO units LED lit.

Using scale factors, it is also possible to gain greater resolution on low voltage circuits. For example, it is possible to report 208V circuits with resolution to 2 decimal places—for example 208.00V. The Circuit Monitor would store this value as 20800 with a scale factor of -2 ($10^{-2}=0.01$). The Circuit Monitor front panel would display the value as 208.00.

Scale factors are arranged in scale groups. The abbreviated register list in Appendix E shows the scale group associated with each metered value.

The Command Interface can be used to change scale factors on a group of metered values. The procedure on the following page tells how.

NOTE

When writing software to read Circuit Monitor data over the communications link, you must account for these scale factors. To correctly read any metered value with a scale factor other than 0, multiply the register value read, by its multiplier.

NOTE

When you change a scale factor, all min/max values are reset.

Setting Scale Factors (cont.) To change scale factors, do the following:

1. Determine the required scale factors

There are 5 scale groups. The desired scale factor for each group must be determined. The following is a listing of the available scale factors for each of the 5 user defined scale groups. The factory default for each scale group is 0. If you need either an extended range or more resolution, you can select any of the available scale factors to suit your need.

Scale Group A - Phase Current

		<u>Scale Factor</u>
Amps	0-327.67 A	-2
	0-3276.7 A	-1
	0-32767 A	0 (default)
	0-327.67 kA	1

Scale Group B - Neutral Current

Amps	0-327.67 A	-2
	0-3276.7 A	-1
	0-32767 A	0 (default)
	0-327.67 kA	1

Scale Group C - Ground Current

Amps	0-327.67 A	-2
	0-3276.7 A	-1
	0-32767 A	0 (default)
	0-327.67 kA	1

Scale Group D Voltage, L-L, L-N

Voltage	0-3276.7 V	-1
	0-32767 V	0 (default)
	0-327.67 kV	1
	0-3276.7 kV	2

Scale Group E Power kW, kVAR, kVA

Power	0-32.767 kW, kVAR, kVA	-3
	0-327.67 kW, kVAR, kVA	-2
	0-3276.7 kW, kVAR, kVA	-1
	0-32767 kW, kVAR, kVA	0 (default)
	0-327.67 MW, MVAR, MVA	1
	0-3276.7 MW, MVAR, MVA	2
	0-32767 MW, MVAR, MVA	3

2. Using PowerLogic Application Software, read the existing scale factors from registers 2020-2024 and write them down.

Register 2020 Scale Group A

Register 2021 Scale Group B

Register 2022 Scale Group C

Register 2023 Scale Group D

Register 2024 Scale Group E

3. Make note of the changes required to the scale groups.

4. Write the appropriate values (see below) to a series of command parameter registers, one for each scale group.

Reg #	Value	Description
7700	2110	Command code to change scale factors. (Min/max will be reset.)
7701-7705	Scale Factors	Scale Group A—write to reg. 7701 Scale Group B—write to reg. 7702 Scale Group C—write to reg. 7703 Scale Group D—write to reg. 7704 Scale Group E—write to reg. 7705
Scale Group A: Ammeter Per Phase		-2 = multiplier of 0.01 -1 = multiplier of 0.10 0 = multiplier of 1.00 (default) 1 = multiplier of 10.0
Scale Group B: Ammeter Neutral		-2 = multiplier of 0.01 -1 = multiplier of 0.10 0 = multiplier of 1.00 (default) 1 = multiplier of 10.0
Scale Group C: Ammeter Ground		-2 = multiplier of 0.01 -1 = multiplier of 0.10 0 = multiplier of 1.00 (default) 1 = multiplier of 10.0
Scale Group D: Voltmeter		-1 = multiplier of 0.10 0 = multiplier of 1.00 (default) 1 = multiplier of 10.0 2 = multiplier of 100.
Scale Group E: kWattmeter, kVarmeter, kVA		-3 = multiplier of 0.001 -2 = multiplier of 0.01 -1 = multiplier of 0.10 0 = multiplier of 1.00 (default) 1 = multiplier of 10.0 2 = multiplier of 100. 3 = multiplier of 1000 4 = multiplier of 10,000 5 = multiplier of 100,000
Scale Group F: Frequency (Determined by CM)		-2 = multiplier of 0.01 (for 50/60 Hz) -1 = multiplier of 0.10 (for 400 Hz)

5. Write a command code (2110) to the Circuit Monitor's command interface register (7700).

SETTING THE DATE AND TIME USING THE COMMAND INTERFACE

The command interface can be used to set the date and time.

To set the date and time, do the following:

1. Write values to a series of command parameter registers, one for each time parameter, YR, MO, DA, HR, MN, SEC.

<u>Reg #</u>	<u>Value</u>	<u>Description</u>
7700	1310	Command code to set date and time.
7701-7706	Sec, min, hr day, mo, yr	Secs corresponds to Register 7701 Mins corresponds to Register 7702 Hours corresponds to Register 7703 Day corresponds to Register 7704 Month corresponds to Register 7705 Year corresponds to Register 7706

2. Write a command code (1310) to the Circuit Monitor's command interface register (7700).

MEMORY ALLOCATION

This section describes memory allocation for nonvolatile *logging* memory only. It does not apply to nonvolatile memory used to store critical values such as setup parameters, min/max values, and energy and demand values. In all Circuit Monitor models, these critical values are stored in a separate nonvolatile memory area.

Circuit Monitors are available with different amounts of nonvolatile logging memory. Depending on the Circuit Monitor model, the available nonvolatile logging memory must be allocated among an event log, 1 to 14 data logs, a waveform capture log, and a 12-cycle event capture log. Specifics for each model are described below.

CM-2050— Provides no nonvolatile logging memory.

CM-2150— Available nonvolatile logging memory must be allocated among an event log and 1 to 14 data logs.

CM-2250— Available nonvolatile logging memory must be allocated among an event log and 1 to 14 data logs.

CM-2350 and Up— Available nonvolatile logging memory must be allocated among an event log, 1 to 14 data logs, a waveform capture log, and a 12-cycle event capture log.

When setting up a Circuit Monitor, the choices you make for the items listed below, directly affect the amount of memory used:

- The number of data log files (1 to 14)
- The quantities logged in each entry (1 to 97), for each data log file
- The maximum number of entries in each data log file
- The maximum number of events in the event log file
- The maximum number of waveform captures in the waveform capture file
- The maximum number of 12-cycle event captures in the 12-cycle event capture file

The number you can enter for each of the above items depends on the amount of the memory that is still available. The amount of memory still available depends on the numbers you've already assigned to the other items.

Figure 12-1 on page 111 shows how the memory might be allocated in a CM-2350. In this figure, the user has set up a waveform capture log, a 12-cycle event capture log, an event log, and three data logs (two small logs, and one larger log). Of the total available nonvolatile memory, about 25% is still available. If the user decided to add a fourth data log file, the file could be no larger than the space still available—25% of the Circuit Monitor's total storage capacity. If the fourth file had to be larger than the space still available, the user would have to reduce the size of one of the other files to free up the needed space.

Memory Allocation (cont.)

POWERLOGIC application software provides a graphical display, similar to figure 12-1. The display uses color coding to show the space devoted to each type of log file along with the space still available. For instructions on setting up log files using POWERLOGIC software, refer to the instruction bulletin included with the software.

For specific instructions on calculating log file sizes, see **Appendix G—Calculating Log File Sizes**.

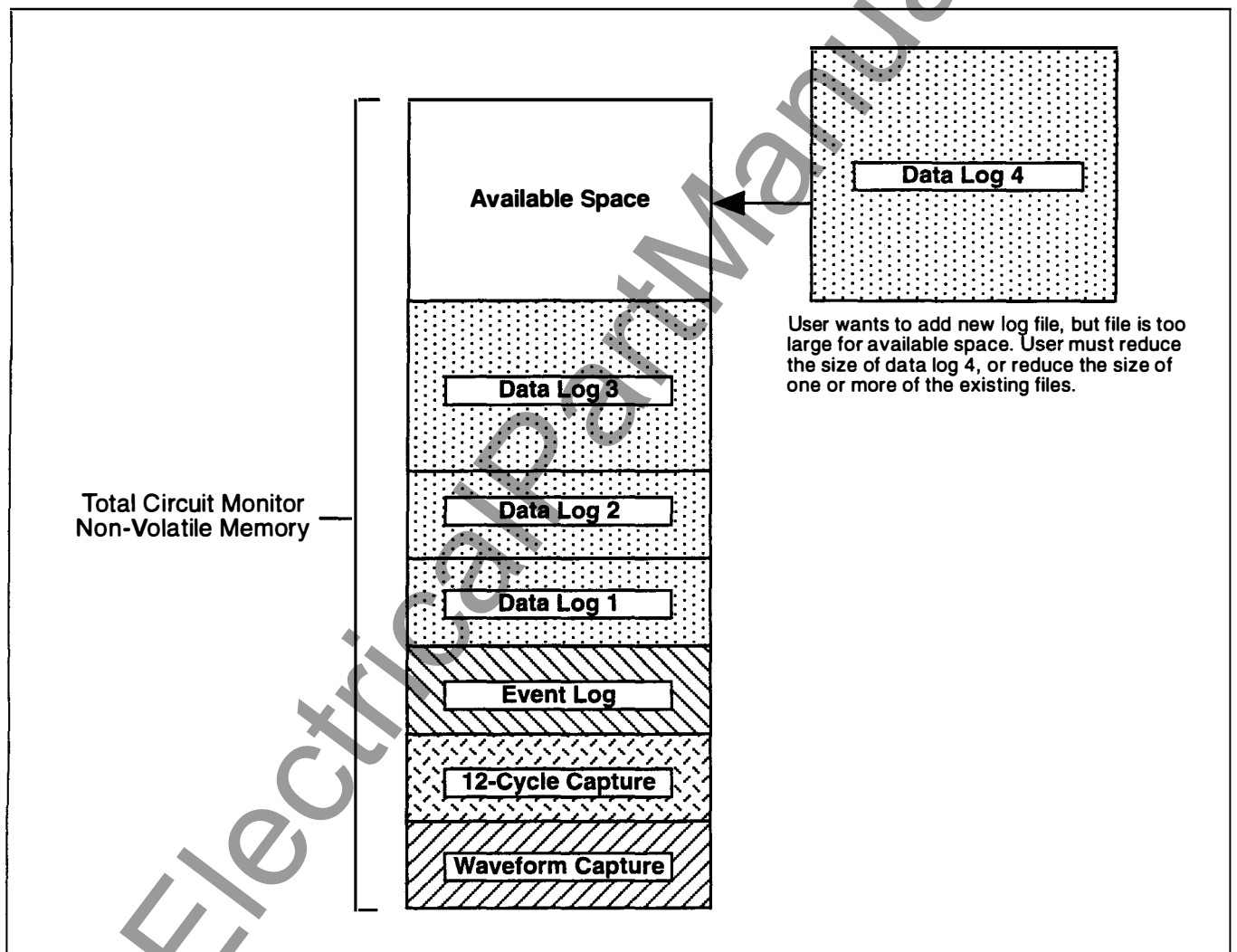

Figure 12-1: Memory allocation example (CM-2350 and higher)

Memory Example

Table 12-1 shows how a user might configure the available memory for various Circuit Monitor models. In this example, the Circuit Monitors have been set up with one data log that stores the following data hourly: 3-phase average amps, volts (L-L, L-N), PF, kW, kVAR, frequency, 3-phase demand for amps, kW, kVA, kWh and kVARH.

The Circuit Monitors store waveform captures and 12-cycle event captures as follows:

- The CM-2250 can store only one waveform capture and one 12-cycle event capture. It stores these in *volatile* memory; therefore they do not reduce the amount of nonvolatile memory available for event and data logs.
- The CM-2350 (and higher) can store multiple waveform captures and 12-cycle event captures. It stores these in *nonvolatile* memory; therefore, they do affect the amount of nonvolatile memory available for event and data logs.

For specific instructions on calculating log file sizes, see Appendix G—Calculating Log File Sizes.

**Table 12-1
 Memory Configuration Example**

Typical Memory Configuration ^①				
	CM-2050	CM-2150	CM-2250	CM-2350/CM-2450
EventLog	N/A	200 Events	200 Events	500 Events
1 Data Log	N/A	8 Days	8 Days	40 Days
Waveform Captures ^②	N/A	N/A	1	3
12 Cycle Event Captures ^②	N/A	N/A	1	3

① The relative size of logfiles is user-defined. This table illustrates a typical memory configuration with one data log that stores the following data hourly: 3Ø avg amps, volts (L-L, L-N), PF, kW, kVAR, freq, 3Ø demand for amps, kW, kVA, and kWh and kVARH.

② Waveform and 12-cycle event captures are stored in nonvolatile memory in the CM-2350 and CM-2450.

HOW POWER FACTOR IS STORED

Each power factor value occupies one register. Power factor values are stored using signed magnitude notation (see figure 12-2). Bit number 16, the sign bit, indicates leading/lagging. A positive value (bit 16=0) indicates leading. A negative value (bit 16=1) indicates lagging. Bits 1-8 store a value in the range 0-100 decimal. Divide power factor values by 100 to get a power factor in the range 0 to 1.00.

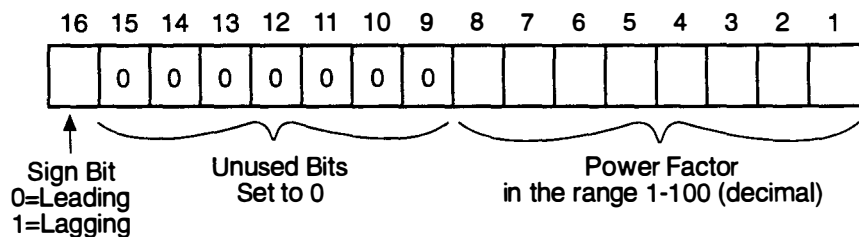

Figure 12-2: Power Factor Register Format

CHANGING THE VAR/ POWER FACTOR SIGN CONVENTION

The Circuit Monitor offers two VAR/Power Factor sign conventions. Figure 12-3 shows the default sign convention. Figure 12-4 shows the alternate sign convention. The procedures below tell how to change the sign convention using the command interface. For a description of the command interface and a complete listing of command codes, see **The Command Interface** in this chapter.

To change to the alternate sign convention, complete the following steps:

1. Write command code 4310 to register 7700.
2. Write command code 1110 to register 7700.

This resets the Circuit Monitor, causing it to use the new convention.

To return to the default sign convention, complete the following steps:

1. Write command code 4311 to register 7700.
2. Write command code 1110 to register 7700.

This resets the Circuit Monitor, causing it to return to the default sign convention.

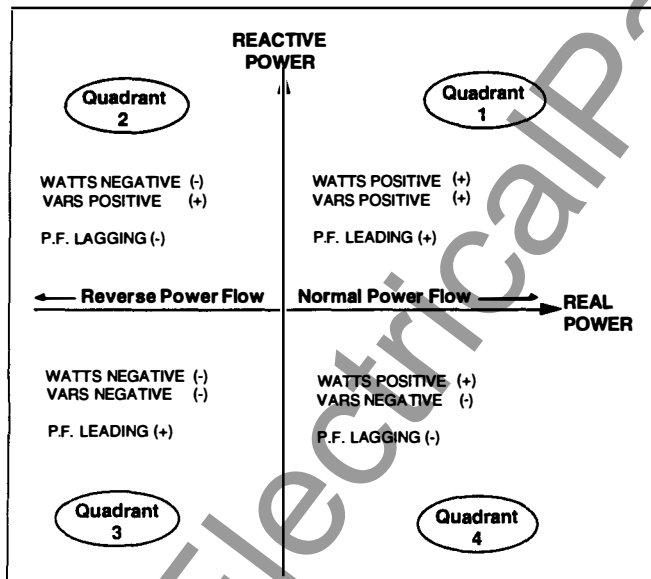

Figure 12-3: Default sign convention

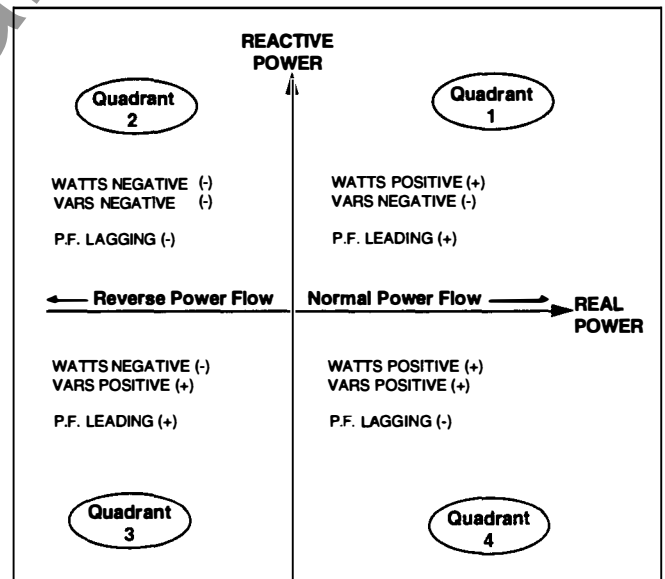

Figure 12-4: Optional sign convention

CONDITIONAL ENERGY

Circuit Monitor registers 1629-1648 are *conditional energy* registers. Conditional energy can be controlled in one of two ways:

- Over the communications link, by writing commands to the Circuit Monitor's command interface
- OR
- By a status input—for example, conditional energy accumulates when the assigned status input is on, but does not accumulate when the status input is off.

The following procedures tell how to set up conditional energy for command interface control, and for status input control. The procedures refer to register numbers and command codes. For a listing of Circuit Monitor registers, see **Appendix E**. For a listing of command codes, see **The Command Interface** in this chapter.

Command Interface Control *To set control of conditional energy to the command interface:*

- Write command code 2341 to register 7700.
To verify proper setup, read register 2081. Bit 6 should read 1, indicating command interface control. Bit 7 should read 0, indicating that condition energy accumulation is off.

To start conditional energy accumulation:

- Write command code 6321 to register 7700.
While conditional energy is accumulating, bit 7 of register 2081 should read 1, indicating that conditional energy accumulation is on.

To stop conditional energy accumulation:

- Write command code 6320 to register 7700.

To clear all conditional energy registers (1629-1648):

1. Write command code 6220 to register 7700.

Status Input Control

To configure conditional energy for status input control:

1. Write command code 2340 to register 7700.
2. Specify the status input that will drive conditional energy accumulation by writing a bitmap to register 7701. Set the appropriate bit to 1 to indicate the desired input (input S1=bit 1, S2=bit 2, S3=bit 3, S4=bit 4).
3. Write command code 3390 to register 7700.

To verify proper setup, read register 2081. Bit 6 should read 0, indicating that conditional energy accumulation is under status input control. Bit 7 should read 0 when the status input is off, indicating that conditional energy accumulation is off. Bit 7 should read 1 when the status input is on, indicating that conditional energy accumulation is on.

To clear all conditional energy registers (1629-1648):

- Write command code 6220 to register 7700.

INCREMENTAL ENERGY

The Circuit Monitor's incremental energy feature allow the user to define a start time and time interval for incremental energy accumulation. At the end of each incremental energy period, the following information is available:

- kWh IN during the last completed interval (reg. 1649-1651)
- kWh OUT during the last completed interval (reg. 1652-1654)
- kVARH IN during the last completed interval (reg. 1655-1657)
- kVARH OUT during the last completed interval (reg. 1658-1660)
- kVAH during the last completed interval (reg. 1661-1663)
- Date/time of the last completed interval (reg. 1869-1871)
- Peak kW during the last completed interval (reg. 1749)
- Date/Time of Peak kW during the last interval (reg. 1878-1880)
- Peak kVAR during the last completed interval (reg. 1750)
- Date/Time of Peak kVAR during the last interval (reg. 1881-1883)
- Peak kVA during the last completed interval (reg. 1751)
- Date/Time of Peak kVA during the last interval (reg. 1884-1886)

The incremental energy data listed above can be logged by the Circuit Monitor. This logged information provide all the information needed to analyze energy and power usage against present or future utility rates. The information is especially useful for doing "what if's" with time-of-use rate structures.

When using the incremental energy feature, keep the following points in mind:

- Peak demands help minimize the size of the data log in cases of sliding or rolling demand. Shorter incremental energy periods make it easier to reconstruct a load profile analysis.
- Since the incremental energy registers are synchronized to the Circuit Monitor clock, it is possible to log this data from multiple circuits and perform accurate totalization.

Using Incremental Energy

To setup incremental energy:

1. Write the desired start date and time to registers 1863-1865.
Incremental energy accumulation begins at the specified date and time. Once the date has arrived, each new day's first incremental energy period begins at the specified time.
2. Write the desired interval length, from 0-1440 minutes, to register 2076.
If incremental energy will be controlled from a remote master, such as a programmable controller, write a value of zero here.

To start a new incremental energy interval from a remote master:

- Write command code 6910 to register 7700.

CHANGING THE DEMAND CALCULATION METHOD

The Circuit Monitor can be configured to use one of three demand power calculation methods:

- thermal demand (Circuit Monitor default)
- external pulse synchronized demand
- block interval demand with rolling subinterval (block/rolling)

For a description of the demand power calculation methods, see **Demand Power Calculation Methods** in Chapter 5.

The thermal demand method is the default. To set up the Circuit Monitor for thermal demand, simply define the demand interval. See **Setting the Demand Interval** in Chapter 4 for instructions.

Changing to the Block/Rolling Method

To change to the block/rolling demand method, the user must write to the command interface over the communications link. (For a description of the command interface and a list of command codes, see **The Command Interface** in this chapter.)

To change to the block/rolling method, complete the following steps:

1. Write command code 5311 to register 7700.
2. Write command code 1110 to command interface register 7700.

This resets the Circuit Monitor causing it to recognize the new demand calculation method.

SETTING UP A DEMAND SYNCH PULSE INPUT

The external pulse synchronized demand method allows a Circuit Monitor, equipped with an I/O module, to accept a demand synch pulse from another demand meter. When this method is used, the Circuit Monitor watches input S1 for a pulse that signals the start of a new demand interval. This allows the Circuit Monitor's demand interval "window" to match the other meter's demand interval "window." For a detailed description of this feature, see **Demand Synch Pulse Input** in Chapter 6.

To set up the Circuit Monitor to accept a demand synch pulse input:

- Set the demand interval to 0. See **Setting the Demand Interval** in Chapter 4 for instructions on setting the demand interval using the Circuit Monitor's front panel.

OR

- Use application software to write command code 5320 to register 7700.

CONTROLLING THE DEMAND INTERVAL OVER THE COMMUNICATIONS LINK

The Circuit Monitor's demand interval can be controlled over the communications link. For example, a programmable controller can signal the start of each new demand interval.

The Circuit Monitor's command interface is used to control the demand interval over the communications link. For a description of the command interface and a list of command codes, see **The Command Interface** in this chapter.

To set demand control to the command interface:

- Write command code 5321 to register 7700.

To start a new demand interval.

- Write command code 5910 to register 7700.

APPENDIX A—CIRCUIT MONITOR DIMENSIONS

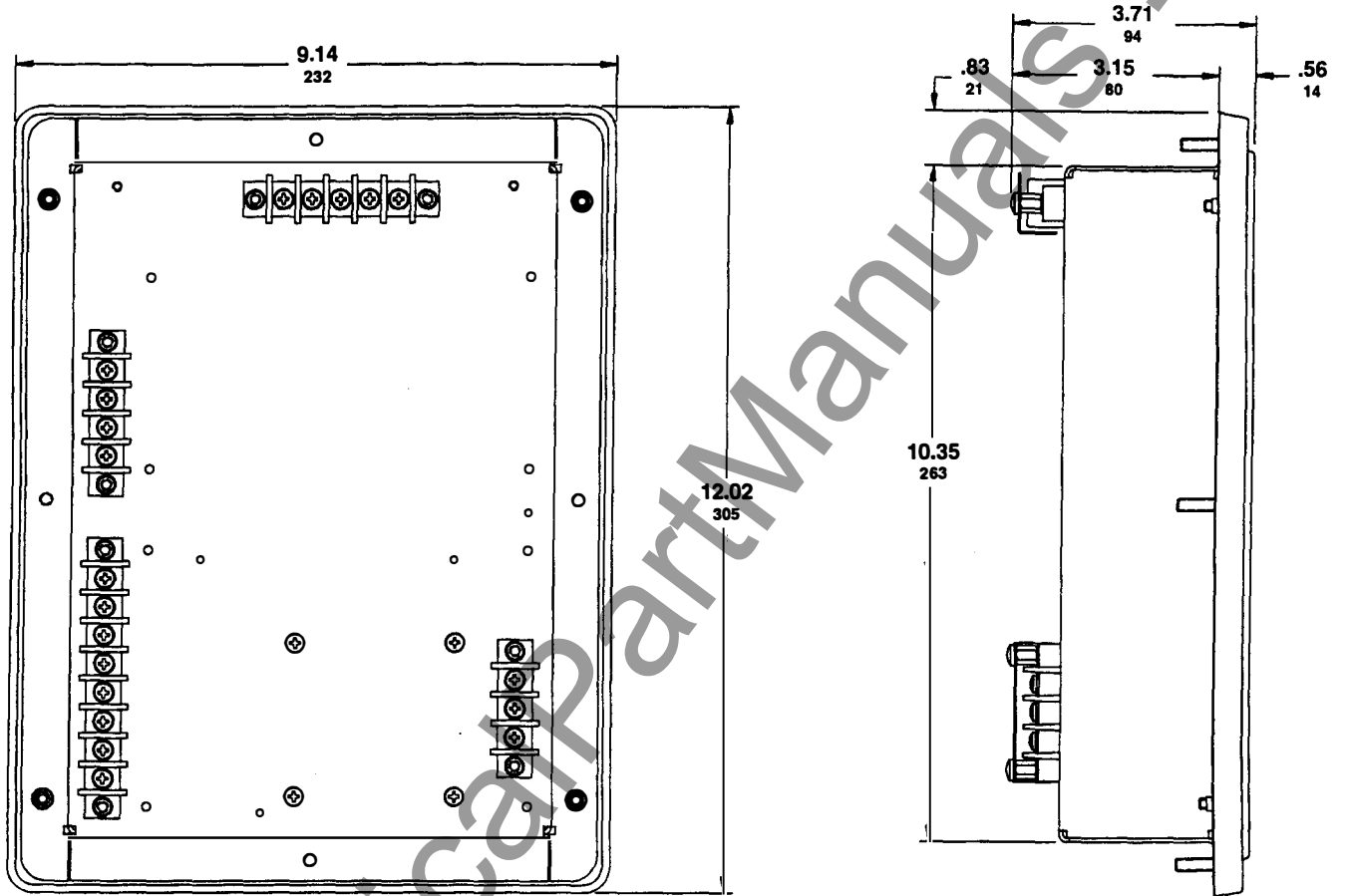

Rear View

Side View

Dimensions	Inches
	Millimeters

Protective covers shown installed.

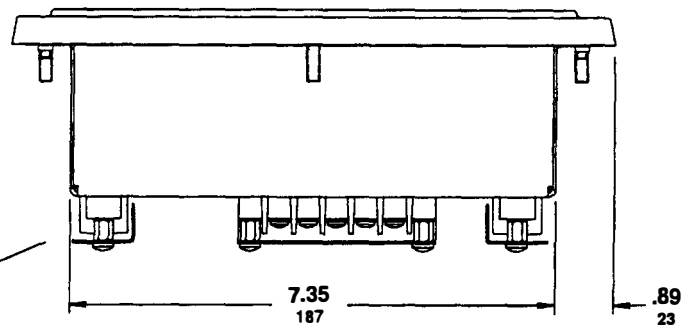

Top View

APPENDIX A (cont.)

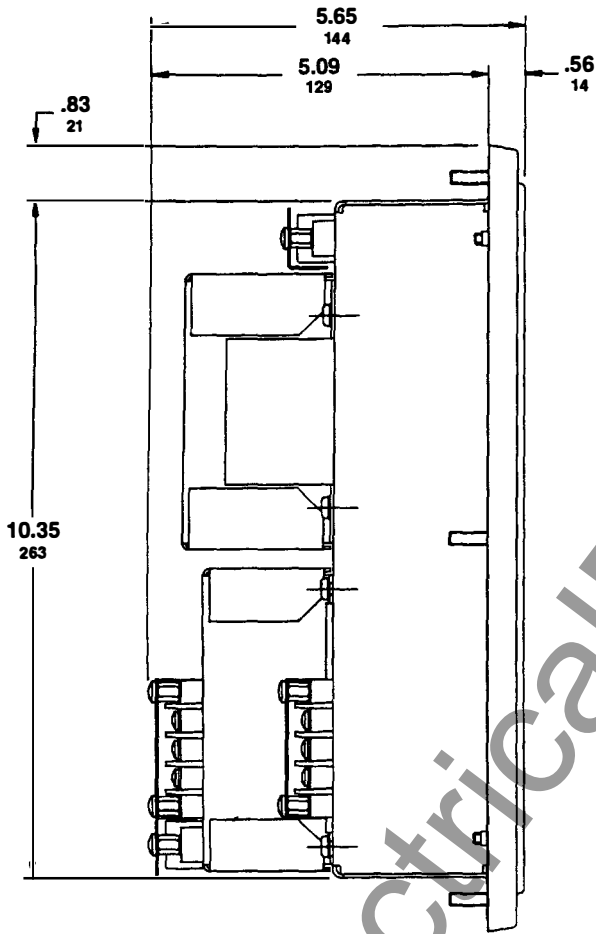

Circuit Monitor with Input/Output and Voltage/Power Modules

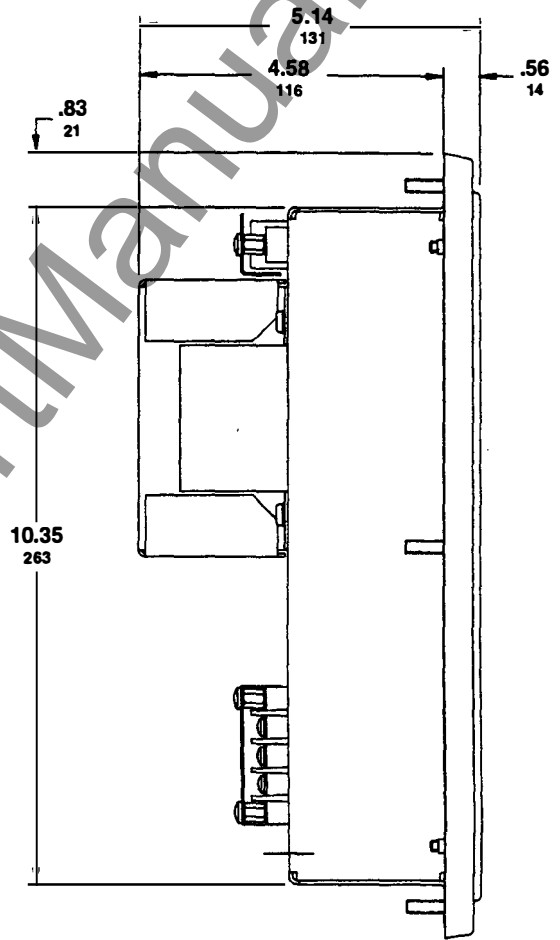

Circuit Monitor with Input/Output Module

Dimensions	<u>Inches</u>
	Millimeters

APPENDIX B—INSTALLING AND WIRING OPTIONAL I/O MODULES

POWERLOGIC offers a number of input/output (I/O) modules for POWERLOGIC Circuit Monitors. Modules are available that provide KYZ pulse outputs, status inputs, relay outputs, analog inputs, and analog outputs. Table B-1 lists the available I/O modules.

This appendix tells how to install an I/O module on the back of the Circuit Monitor. It also lists technical specifications and shows typical I/O wiring connections. For a description of the Circuit Monitor's I/O capabilities, see **Chapter 6—Input/Output Capabilities**.

Table B-1
Input/Output Modules

Class	Type	Description
3020	IOM-11	1 status IN, 1 KYZ pulse OUT
3020	IOM-18	8 status IN, 1 KYZ pulse OUT
3020	IOM-44	4 status IN, 1 KYZ pulse OUT, 3 Form-C relay OUT
3020	IOM-4411-01	4 status IN, 1 KYZ pulse OUT, 3 Form-C relay OUT, 1 Analog IN [Ⓞ] , 1 Analog OUT (0–1 mA)
3020	IOM-4411-20	4 status IN, 1 KYZ pulse OUT, 3 Form-C relay OUT, 1 Analog IN [Ⓞ] , 1 Analog OUT (4–20 mA)
3020	IOM-4444-01	4 status IN, 1 KYZ pulse OUT, 3 Form-C relay OUT, 4 Analog IN [Ⓞ] , 4 Analog OUT (0–1 mA)
3020	IOM-4444-20	4 status IN, 1 KYZ pulse OUT, 3 Form-C relay OUT, 4 Analog IN [Ⓞ] , 4 Analog OUT (4–20 mA)

[Ⓞ] Analog Inputs are 0-5 Vdc. Each analog input can be independently configured to accept a 4-20 mA input by connecting an external jumper wire (see **Analog Input Connections** in this appendix).

SPECIFICATIONS

Status Inputs

Type of isolation	Optical
Voltage operating range	20-138 Vac/Vdc
Input current draw (maximum)	1 mA @ 20 volts; 6 mA @ 138 volts
Must turn on voltage	20 volts rms
Must turn on current	1 mA (at 20 volts)
Must turn off voltage	9 volts rms
Must turn off current (maximum)	0.3 mA (at 9 volts)
Input impedance	27.2K ohms resistive
Turn on time (maximum)	0.5 msec (dc); 8 msec (ac)
Turn off time (maximum)	16 msec

Relay Output Ratings

KYZ	96 mA max. at 240Vac/300Vdc
R1-R3	10A max. at 240Vac/30Vdc

Analog Input Ratings[Ⓞ]

Default Input Range	0-5 Vdc
Optional Input Range [Ⓢ]	0-20 mA
Accuracy	0.25% full scale

Analog Output Ratings[Ⓞ]

Output Range, 4-20 mA models	4-20 mA (20 mA into 600 ohms max.)
Output Range, 0-1 mA models	0-1 mA (1 mA into 10,000 ohms max.)
Accuracy	1% full scale

Ⓞ The IOM-4444 provides 1 shield for all four inputs, and 1 shield for all four outputs.

Ⓢ To accept a 4-20 mA signal, you must connect a jumper wire to the appropriate terminals on the input module (see Analog Input Connections on page 6). The jumper wire places an internal 250 ohm resistor into the circuit.

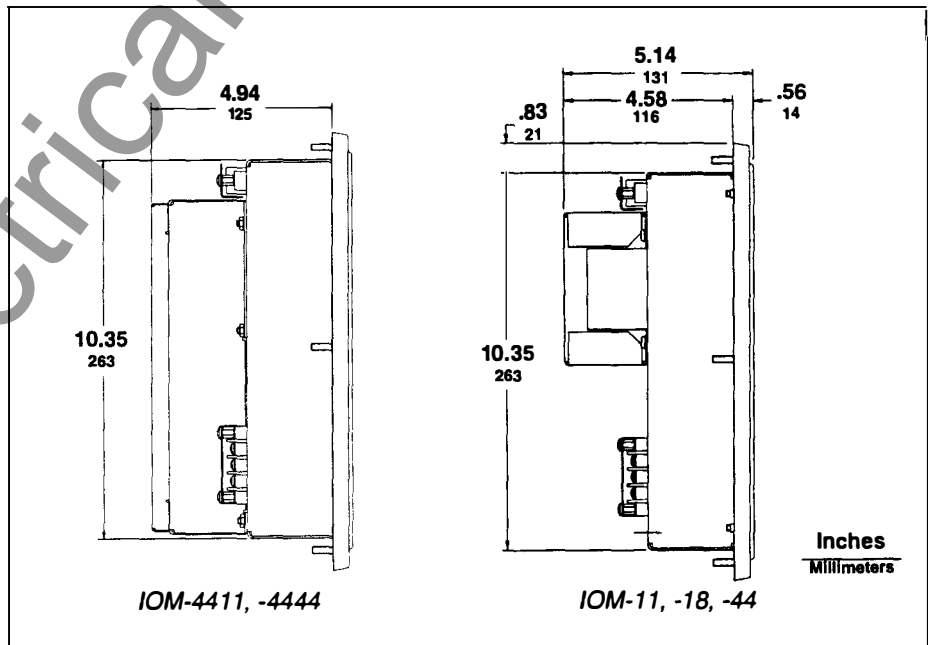

Figure B-1: CM dimensions with I/O modules installed

**INSTALLING AN IOM-11,
IOM-18, OR IOM-44**

This section tells how to install the IOM-11, IOM-18, or IOM-44 on the back of the Circuit Monitor. The procedure is the same for all modules. Figure B-2 illustrates the installation procedure. Figure B-1 shows the dimensions of the Circuit Monitor with the I/O module installed.

To install the module, complete the following steps:

1. Remove the connector guard from the I/O connector protruding through the back of the Circuit Monitor.
2. Plug the I/O module's ribbon cable connector into the I/O connector on the back of the Circuit Monitor.

Do not twist or pinch the ribbon cable as you place the module against the Circuit Monitor.

3. Guide the module's mounting holes onto the four mounting posts on the top half of the Circuit Monitor. Secure the module to the Circuit Monitor using four #6-32 nuts with external tooth washers (supplied with the module's hardware kit 63230-204-19). Tighten to 6–9 lb-in (0.68–1.01 N•m) of torque.

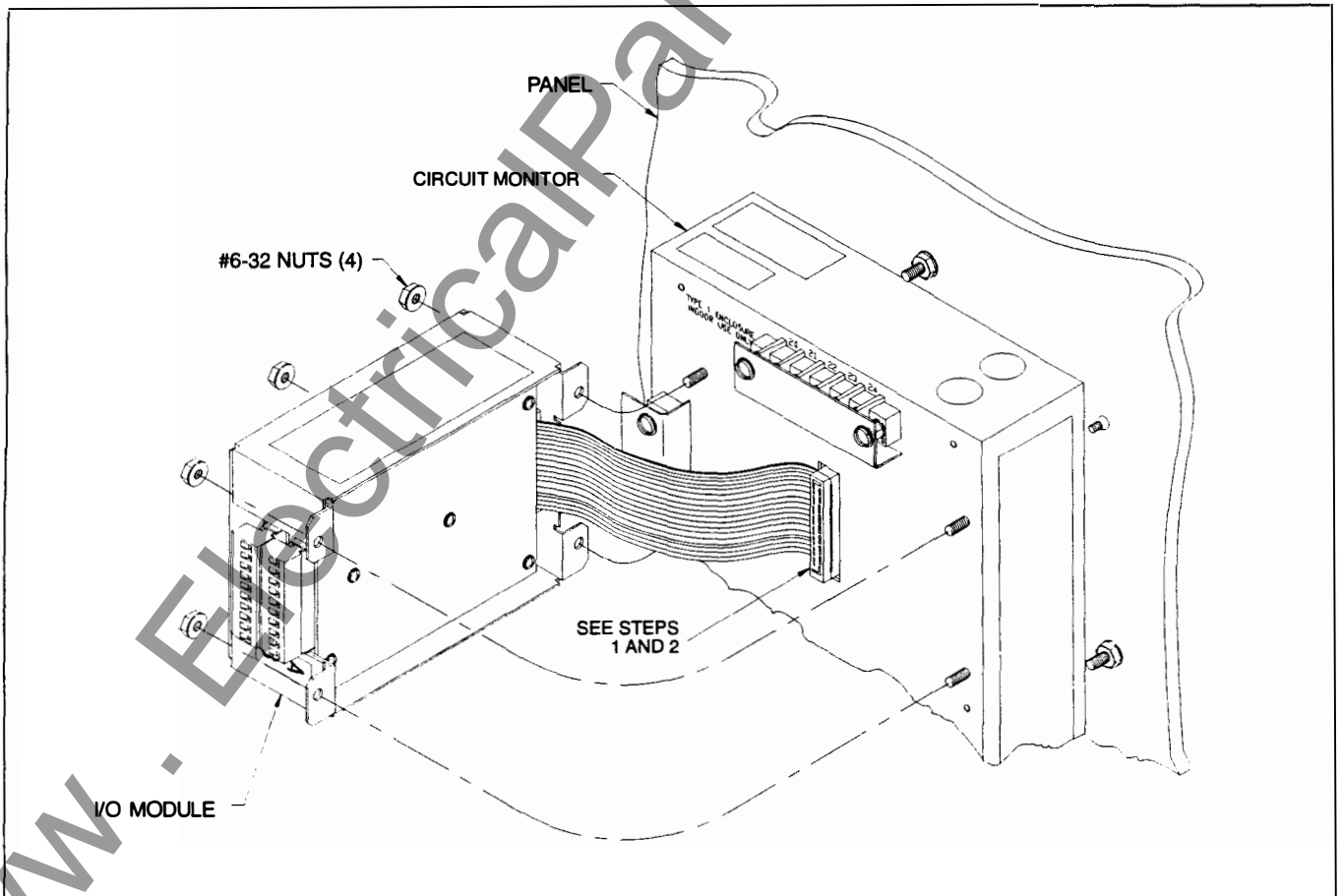

Figure B-2: Installing an IOM-11, IOM-18, or IOM-44

INSTALLING AN IOM-4411 OR IOM-4444

This section tells how to install the IOM-4411, or IOM-4444 on the back of the Circuit Monitor. The procedure is the same for both modules. Figure B-3 illustrates the installation procedure. Figure B-1 shows the dimensions of the Circuit Monitor with the I/O modules installed.

To install the module, complete the following steps:

1. Remove the connector guard from the I/O connector protruding through the back of the Circuit Monitor.
2. Plug the I/O module's ribbon cable connector into the I/O connector on the back of the Circuit Monitor.

Do not twist or pinch the ribbon cable as you place the module against the Circuit Monitor.

3. Guide the module's mounting holes onto the seven mounting posts on the Circuit Monitor. Secure the module to the Circuit Monitor using seven #6-32 nuts (supplied with the I/O module's hardware kit). Tighten to 6-9 lb-in (0.68-1.01 N•m) of torque.

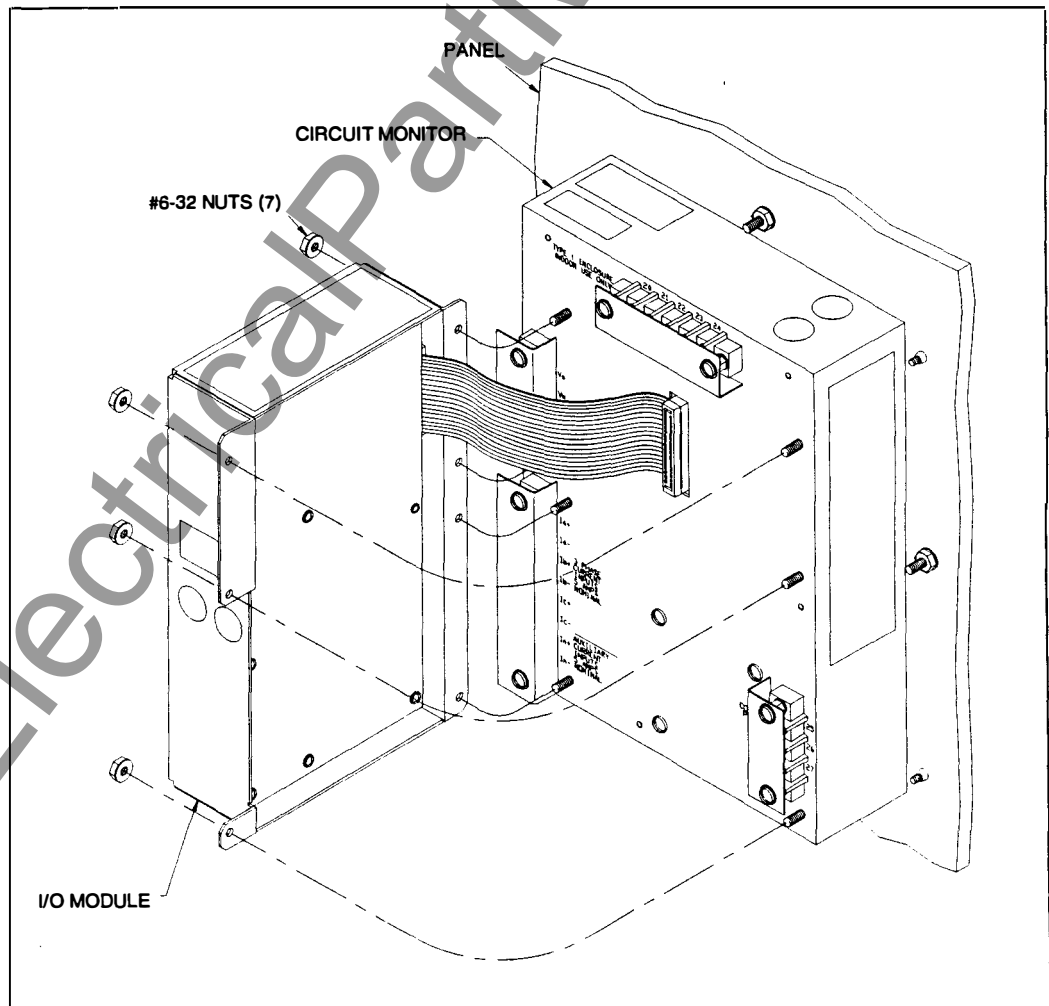

Figure B-3: Installing an IOM-4411 or IOM-4444

STATUS INPUT CONNECTIONS

The IOM-4411 and IOM-4444 modules offer 4 status inputs each. Status inputs can be used to sense the state of external contacts.

Figure B-4 shows typical status input connections. Figure B-10 on page 130 shows the terminal label for each module. When wiring the module, use only 14 to 18 gauge stranded wire. Strip 0.25" (6mm) from the end of each wire being connected to the module.

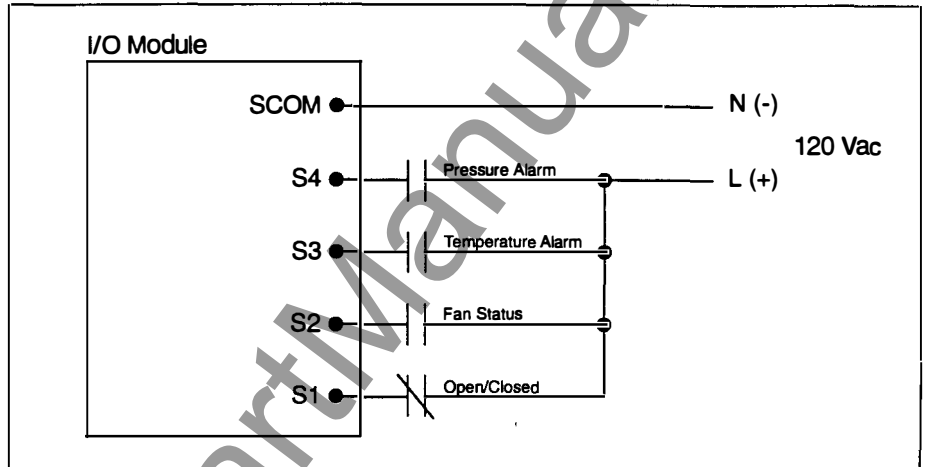

Figure B-4: Typical status input connections

RELAY OUTPUT CONNECTIONS

The IOM-4411 and IOM-4444 modules offer 3 relay outputs each. Relay outputs can be used to open or close circuit breakers or contactors, annunciator alarms, and so on.

Each relay output provides three terminals—normally closed, normally open, and common. Figure B-10 shows the terminal labels for the I/O modules. Figure B-5 shows a typical relay output connection. When wiring the module, use only 14 to 18 gauge stranded wire. Strip 0.25" (6mm) from the end of each wire being connected to the module.

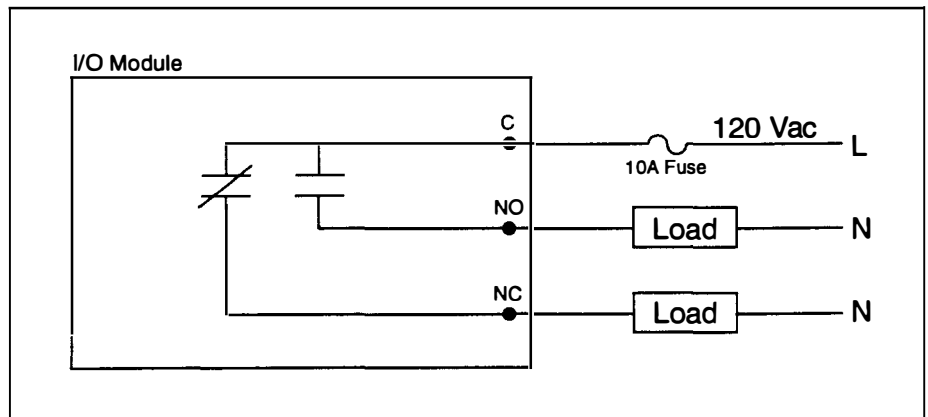

Figure B-5: Typical relay output connections

PULSE OUTPUT CONNECTIONS

Each I/O module provides one solid-state, KYZ pulse output. See **Solid State KYZ Pulse Output** in **Chapter 6** for a description of the Circuit Monitor's pulse output capabilities.

The pulse output can be wired to a 2-wire or 3-wire pulse receiver. To wire to a 2-wire pulse receiver, use the K and Y terminals only (see figure B-4). When wiring the module, use only 14 to 18 gauge stranded wire. Strip 0.25" (6mm) from the end of each wire being connected to the module.

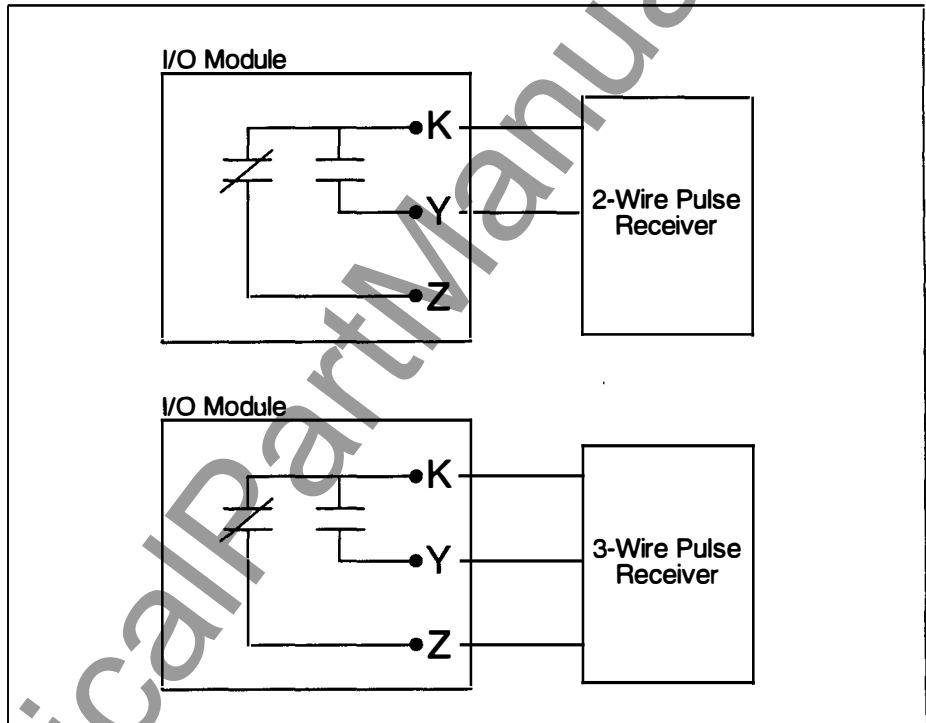

Figure B-6: Pulse output

ANALOG INPUT CONNECTIONS

I/O modules IOM-4411 and IOM-4444 offer one and four analog inputs, respectively (see table 1 on page 1). Analog inputs can be used to monitor analog quantities such as oil pressure, water temperature, and so on.

Figure B-7 shows analog input wiring connections for a 0-5 Vdc input signal. Figure B-8 shows analog input wiring connections for a 4-20 mA signal.

To configure an analog input to accept a 4-20 mA signal, do the following:

1. Connect the jumper to the IN1 (+) and IN1 (-) terminals (see figure B-8). This places a 250 ohm resistor (located inside the I/O module) into the circuit. When a 4-20 mA current is run through the resistor, the Circuit Monitor measures an input voltage of 1-5 volts across the resistor.
2. Using application software, configure the analog input to accept a 4-20 mA input signal. This instructs the Circuit Monitor to use a separate set of calibration constants specifically for the 250 ohm internal resistor. (See the POWERLOGIC software instruction bulletin for instructions.)

When wiring the module, use only 14 to 18 gauge stranded wire. Strip 0.25" (6mm) from the end of each wire being connected to the module.

 <b style="font-size: 1.2em; margin-left: 10px;">WARNING
<p>HAZARD OF ELECTRIC SHOCK.</p> <p>Ground the shield at one end only. Grounding the shield at both ends may create a ground loop, causing hazardous voltages to be present on the Circuit Monitor chassis.</p> <p>Failure to observe this warning may result in injury or death.</p>

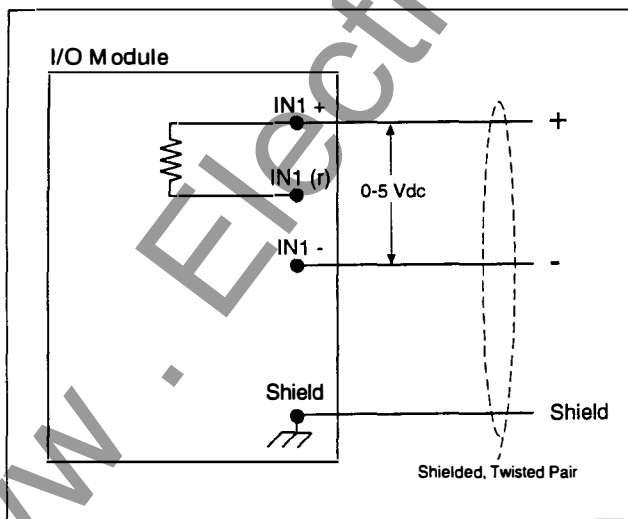

Figure B-7: Connections for 0-5 Vdc Input Signal

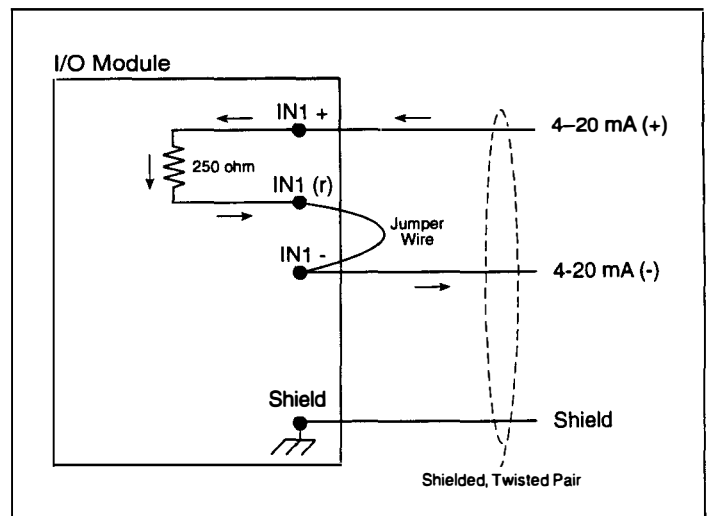



Figure B-8: Connections for 4-20 mA Input Signal

**ANALOG OUTPUT
CONNECTIONS**

I/O modules IOM-4411 and IOM-4444 offer one and four analog outputs, respectively. Each analog output can be associated with a Circuit Monitor register to output an analog signal in direct proportion to the register contents.

Figure B-9 shows typical analog output connections. Figure B-10 on page 130 shows the terminal label for each module. When wiring the module, use only 14 to 18 gauge stranded wire. Strip 0.25" (6mm) from the end of each wire being connected to the module.

 WARNING
HAZARD OF ELECTRIC SHOCK.
Ground the shield at one end only. Grounding the shield at both ends may create a ground loop, causing hazardous voltages to be present on the Circuit Monitor chassis.
Failure to observe this warning may result in injury or death.

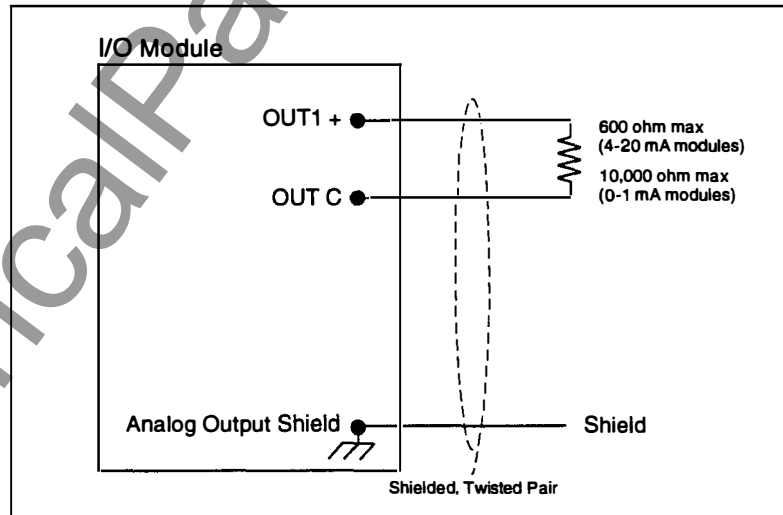

Figure B-9: Typical Analog Output Wiring Connections

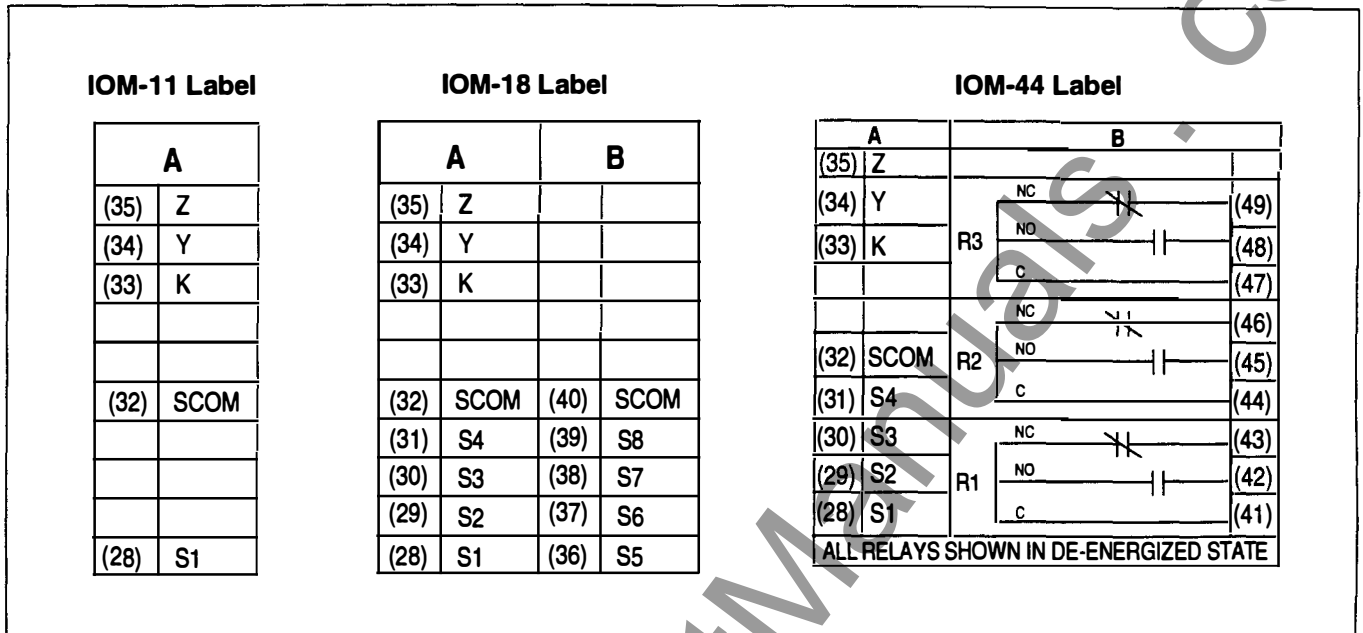

Figure B-10: I/O module terminal labels

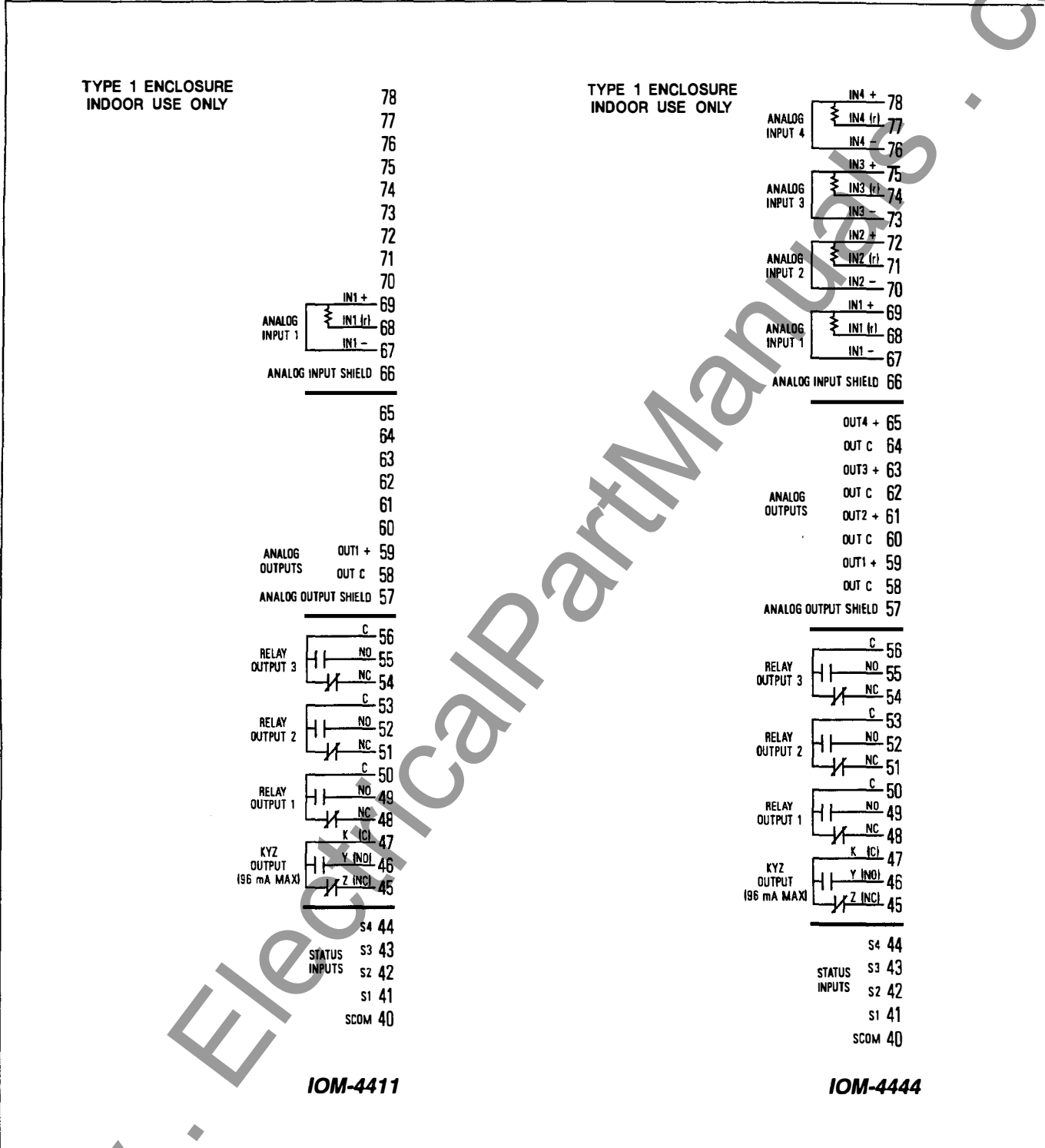

Figure B-11: IOM-4411 and IOM-4444 Silk Screens

APPENDIX C—INSTALLING THE OPTIONAL VOLTAGE/POWER MODULE

The voltage/power module allows direct connection of a single Series 2000 Circuit Monitor to 480Y/277V systems—without the need for voltage transformers or control power transformers. The module is mounted on the back of the Circuit Monitor or on a nearby flat surface, and is wired to the Circuit Monitor.

The voltage/power module provides a 288:120V ratio when connected to the Series 2000 Circuit Monitor voltage inputs. When a VPM-277-C1 is connected to a Series 2000 Circuit Monitor, set up the Circuit Monitor for a 288:120V PT ratio. The VPM-277-C1 will not provide a 288:120V ratio when connected to other devices not specifically designed for use with the VPM-277-C1.

SPECIFICATIONS

Voltage

Nominal Input	480Y/277V
Nominal Control Power Output	120 Vac, 14 VA
Ratio when Connected to Series 2000 Circuit Monitor	288:120 Vac
Metering Accuracy	0.3%
Frequency Range	45 to 65 Hz
Burden (Phase A, control power source)	15 VA
Burden (Phase B and C)	less than 0.1 VA

DANGER

HAZARD OF ELECTRIC SHOCK.

Only qualified electrical workers should install and wire the voltage power module. Such work should be performed only after reading this entire bulletin.

Failure to observe this precaution will result in severe personal injury or death!

CAUTION

HAZARD OF EQUIPMENT DAMAGE.

Each voltage/power module is intended to supply only one Circuit Monitor. Do not attempt to use a voltage/power module with more than one Circuit Monitor.

Failure to observe this precaution could cause overheating, and damage the voltage/power module.

MOUNTING THE MODULE

Figure C-2 shows the voltage/power module mounted on a Circuit Monitor. Refer to figure C-2 when completing the following steps.

To mount the module on the Circuit Monitor, complete the following steps:

1. Align the mounting holes on the voltage/power module with the four mounting posts on the lower half of the Circuit Monitor.
2. Place the module on the posts, and secure the module to the Circuit Monitor using four #6-32 hex nuts with external tooth washers. The hex nuts are included in the voltage/power module's hardware kit.

NOTE

Some electrical codes may not allow 480 volts at the front of the equipment. In this case, mount the voltage/power module where codes permit, and wire to the Circuit Monitor. See figure C-1 for module dimensions.

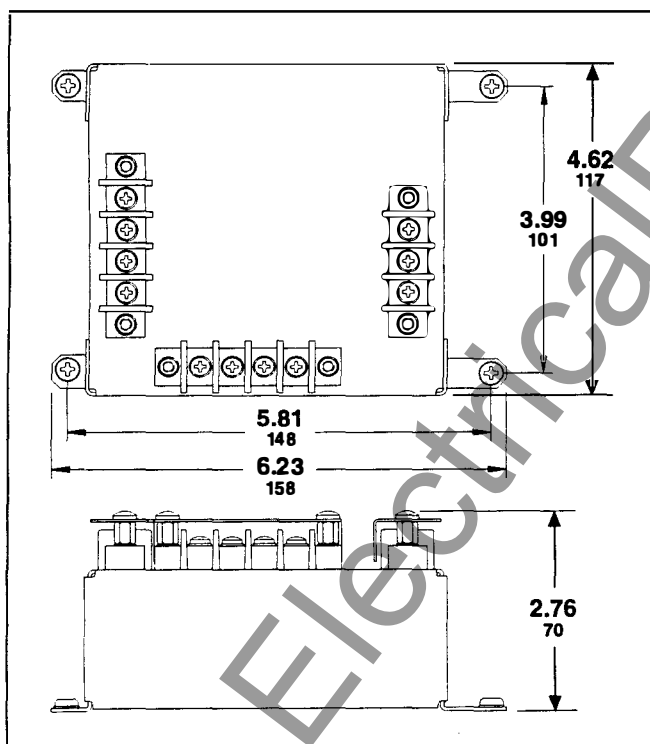

Figure C-1: Voltage/power module dimensions.

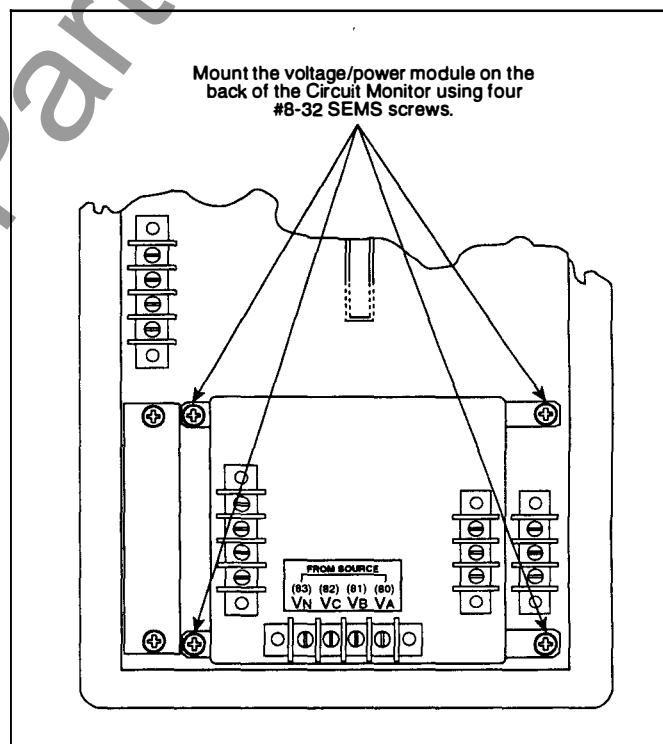

Figure C-2: Mounting the voltage/power module on the back of the Circuit Monitor.

WIRING THE MODULE

Note: The spade connectors and terminal strip covers mentioned below are included in the hardware kit (63230-204-20) supplied with the module. Wiring instructions are also included in the hardware kit.

Refer to figures C-3 and C-4 when completing the following steps.

To wire the module, complete the following steps:

1. Using a Thomas and Betts crimping tool, catalog no. Wt1455 or equivalent, crimp the blue spade connectors onto the wires used to connect the voltage/power module.
2. Connect the Circuit Monitor voltage input terminals 12, 11, 10, and 9 to voltage/power module voltage output terminals 87, 86, 85, and 84, respectively, as shown in figure C-3.
3. Connect Circuit Monitor control power input terminals 25, 26, and 27 to voltage/power module control power input terminals 88, 89, and 90, respectively, as shown in figure C-3.
4. Connect the Circuit Monitor's Ground terminal (terminal 26) to a true earth ground, using a #14 AWG (or larger) wire with a spade connector. See figure C-4.
5. Wire the voltage/power module's voltage input terminals 80, 81, 82, and 83 to the corresponding phase, as shown in figure C-4.
The recommended fuse is BUSS KTK-1 600 volt 1 amp, or equivalent.
6. Install the terminal strip covers over the terminal strips using the #8-32 SEMS screws provided in the hardware kit.

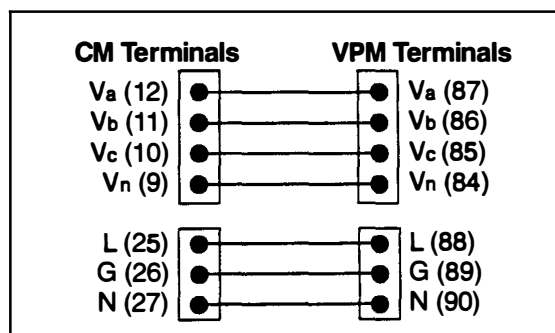

Figure C-3: Terminal connections between Circuit Monitor and voltage/power module.

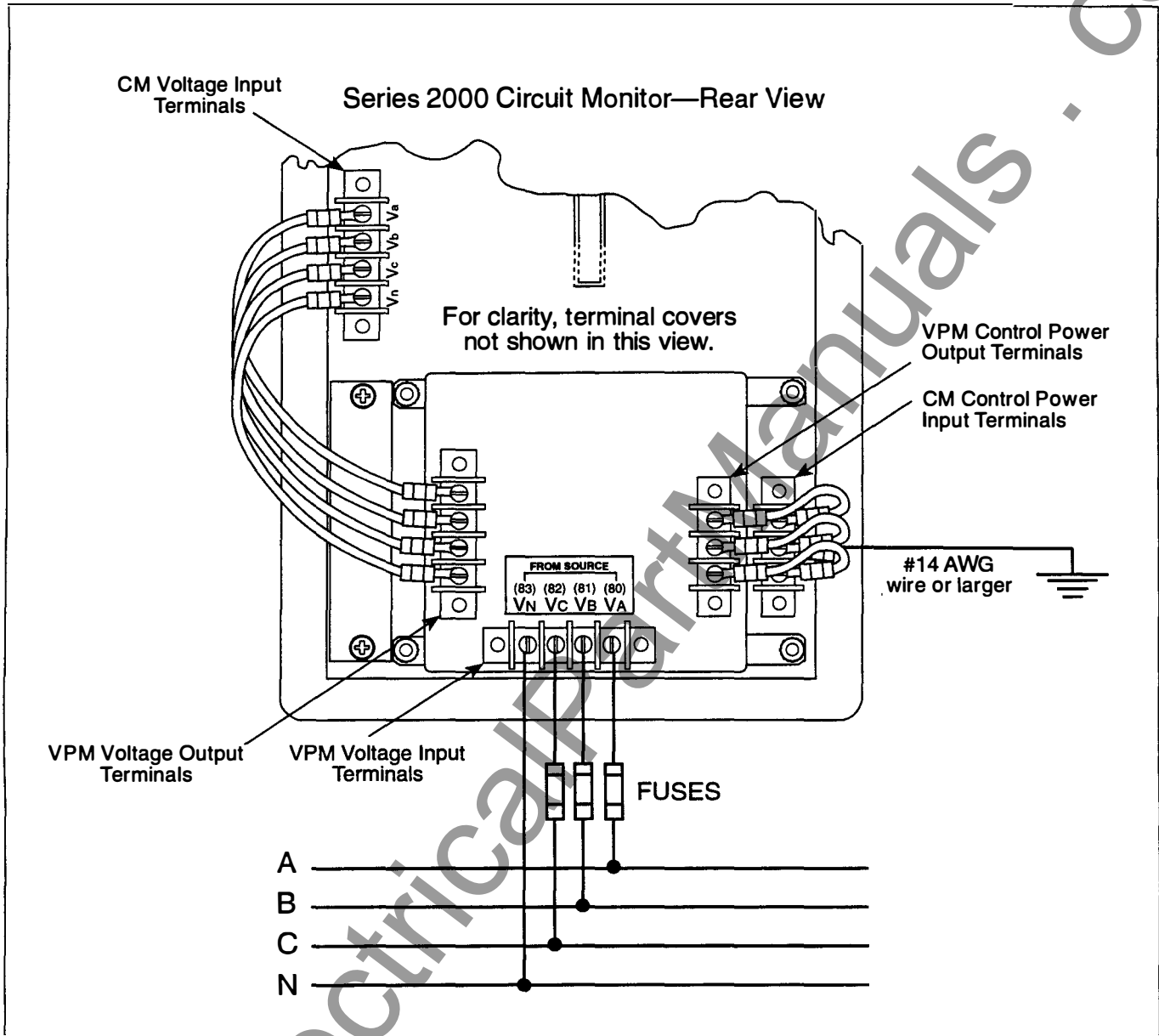
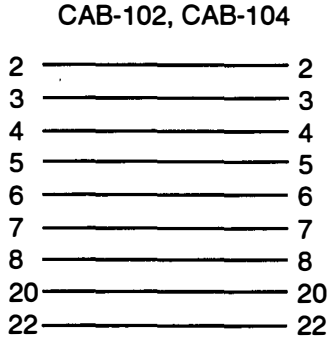
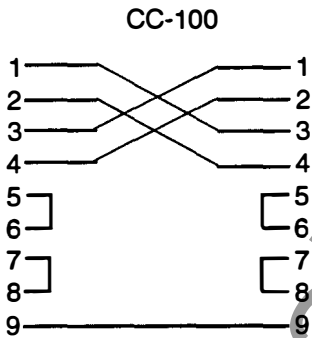
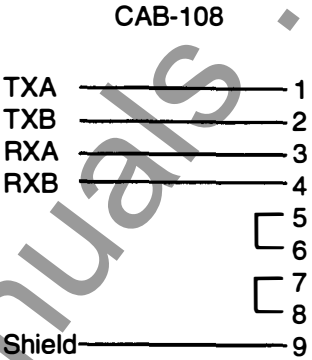
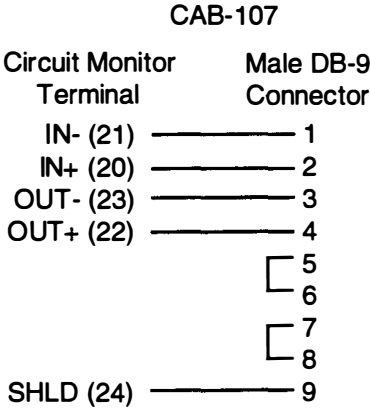

Figure C-4: Wiring the voltage/power module .

APPENDIX D—COMMUNICATION CABLE PINOUTS



APPENDIX E—ABBREVIATED REGISTER LISTING

This appendix offers an abbreviated listing of Circuit Monitor registers. The following values are included in this register listing:

- Real-Time Metered Values
- Real-Time Meter Values Minimum
- Real-Time Meter Values Maximum
- Energy Values
- Demand Values
- Dates and Times
- Status Inputs
- Relay Outputs
- Circuit Monitor Configuration Values

In this appendix, the following information is provided for each register:

- Register Number (see note below)
- Register Description
- Units
- Range

<u>Reg. #</u>	<u>Description</u>	<u>Units</u>	<u>Range</u>
1000	Update Interval	In 1000ths of a second	0 to 10,000
1001	Frequency	Hertz/Scale Factor F	2300 to 6700 (50/60)
1002	Temperature inside CM enclosure	Degrees C in 10ths	-1000 to +1000
1003	Current, Phase A	Amps/Scale Factor A	0 to 32,767
1004	Current, Phase B	Amps/Scale Factor A	0 to 32,767
1005	Current, Phase C	Amps/Scale Factor A	0 to 32,767
1006	Current, Neutral	Amps/Scale Factor B	0 to 32,767
1007	Current, Ground	Amps/Scale Factor C	0 to 32,767
1008	Current, 3-Phase Average	Amps/Scale Factor A	0 to 32,767
1009	Current, Apparent rms	Amps/Scale Factor A	0 to 32,767
1010	Current Unbalance, Phase A	Percent in 10ths	0 to ±1000
1011	Current Unbalance, Phase B	Percent in 10ths	0 to ±1000
1012	Current Unbalance, Phase C	Percent in 10ths	0 to ±1000
1013	Current Unbalance, Worst	Percent in 10ths	0 to ±1000
1014	Voltage, Phase A to B	Volts/Scale Factor D	0 to 32,767
1015	Voltage, Phase B to C	Volts/Scale Factor D	0 to 32,767
1016	Voltage, Phase C to A	Volts/Scale Factor D	0 to 32,767
1017	Voltage L-L, 3-Phase Average	Volts/Scale Factor D	0 to 32,767
1018	Voltage, Phase A to Neutral	Volts/Scale Factor D	0 to 32,767
1019	Voltage, Phase B to Neutral	Volts/Scale Factor D	0 to 32,767
1020	Voltage, Phase C to Neutral	Volts/Scale Factor D	0 to 32,767
1021	Voltage L-N, 3-Phase Average	Volts/Scale Factor D	0 to 32,767
1022	Voltage Unbalance, Phase A-B	Percent in 10ths	0 to ±1000
1023	Voltage Unbalance, Phase B-C	Percent in 10ths	0 to ±1000
1024	Voltage Unbalance, Phase C-A	Percent in 10ths	0 to ±1000
1025	Voltage Unbalance, L-L Worst	Percent in 10ths	0 to ±1000
1026	Voltage Unbalance, Phase A	Percent in 10ths	0 to ±1000
1027	Voltage Unbalance, Phase B	Percent in 10ths	0 to ±1000
1028	Voltage Unbalance, Phase C	Percent in 10ths	0 to ±1000
1029	Voltage Unbalance, L-N Worst	Percent in 10ths	0 to ±1000
1031	True Power Factor, Phase A	In 1000ths	-100 to +1000 to +100
1032	True Power Factor, Phase B	In 1000ths	-100 to +1000 to +100
1033	True Power Factor, Phase C	In 1000ths	-100 to +1000 to +100
1034	True Power Factor, 3-Phase Total	In 1000ths	-100 to +1000 to +100
1035	Displacement Power Factor, Phase A	In 1000ths	-100 to +1000 to +100
1036	Displacement Power Factor, Phase B	In 1000ths	-100 to +1000 to +100
1037	Displacement Power Factor, Phase C	In 1000ths	-100 to +1000 to +100
1038	Displacement Power Factor, 3-Phase Total	In 1000ths	-100 to +1000 to +100
1039	Real Power, Phase A	kW/Scale Factor E	0 to ±32,767
1040	Real Power, Phase B	kW/Scale Factor E	0 to ±32,767
1041	Real Power, Phase C	kW/Scale Factor E	0 to ±32,767
1042	Real Power, 3-Phase Total	kW/Scale Factor E	0 to ±32,767
1043	Reactive Power, Phase A	kVAr/Scale Factor E	0 to ±32,767
1044	Reactive Power, Phase B	kVAr/Scale Factor E	0 to ±32,767
1045	Reactive Power, Phase C	kVAr/Scale Factor E	0 to ±32,767
1046	Reactive Power, 3-Phase Total	kVAr/Scale Factor E	0 to ±32,767
1047	Apparent Power, Phase A	kVA/Scale Factor E	0 to +32,767
1048	Apparent Power, Phase B	kVA/Scale Factor E	0 to +32,767
1049	Apparent Power, Phase C	kVA/Scale Factor E	0 to +32,767
1050	Apparent Power, 3-Phase Total	kVA/Scale Factor E	0 to +32,767

<u>Reg. #</u>	<u>Description</u>	<u>Units</u>	<u>Range</u>
1051	THD Phase A Current	% in 10ths	0 to 32,767
1052	THD Phase B Current	% in 10ths	0 to 32,767
1053	THD Phase C Current	% in 10ths	0 to 32,767
1054	THD Phase Neutral Current	% in 10ths	0 to 32,767
1055	THD Phase A Voltage	% in 10ths	0 to 32,767
1056	THD Phase B Voltage	% in 10ths	0 to 32,767
1057	THD Phase C Voltage	% in 10ths	0 to 32,767
1058	THD Phase A-B Voltage	% in 10ths	0 to 32,767
1059	THD Phase B-C Voltage	% in 10ths	0 to 32,767
1060	THD Phase C-A Voltage	% in 10ths	0 to 32,767
1061	THD Phase A Current	% in 10ths	0 to 32,767
1062	thd Phase B Current	% in 10ths	0 to 32,767
1063	thd Phase C Current	% in 10ths	0 to 32,767
1064	thd Phase Neutral Current	% in 10ths	0 to 32,767
1065	thd Phase A Voltage	% in 10ths	0 to 32,767
1066	thd Phase B Voltage	% in 10ths	0 to 32,767
1067	thd Phase C Voltage	% in 10ths	0 to 32,767
1068	thd Phase A-B Voltage	% in 10ths	0 to 32,767
1069	thd Phase B-C Voltage	% in 10ths	0 to 32,767
1070	thd Phase C-A Voltage	% in 10ths	0 to 32,767
1071	K-Factor, Phase A	In 10ths	0 to 10,000
1072	K-Factor, Phase B	In 10ths	0 to 10,000
1073	K-Factor, Phase C	In 10ths	0 to 10,000
1074	Crest Factor, Phase A	In 100ths	0 to 10,000
1075	Crest Factor, Phase B	In 100ths	0 to 10,000
1076	Crest Factor, Phase C	In 100ths	0 to 10,000
1077	Crest Factor, Neutral	In 100ths	0 to 10,000
1078	Phase A Current, Fundamental rms Magnitude	Amps/Scale Factor A	0 to 32,767
1079	Phase A Current, Fundamental Coincident Angle	In 10ths of degrees	0 to 3,599
1080	Phase B Current, Fundamental rms Magnitude	Amps/Scale Factor A	0 to 32,767
1081	Phase B Current, Fundamental Coincident Angle	In 10ths of degrees	0 to 3,599
1082	Phase C Current, Fundamental rms Magnitude	Amps/Scale Factor A	0 to 32,767
1083	Phase C Current, Fundamental Coincident Angle	In 10ths of degrees	0 to 3,599
1084	Neutral Current, Fundamental rms Magnitude	Amps/Scale Factor B	0 to 32,767
1085	Neutral Current, Fundamental Coincident Angle	In 10ths of degrees	0 to 3,599
1086	Ground Current, Fundamental rms Magnitude	Amps/Scale Factor C	0 to 32,767
1087	Ground Current, Fundamental Coincident Angle	In 10ths of degrees	0 to 3,599
1088	Phase A Voltage, Fundamental rms Magnitude	Volts/Scale Factor D	0 to 32,767
1089	Phase A Voltage, Fundamental Coincident Angle	In 10ths of degrees	0 to 3,599
1090	Phase B Voltage, Fundamental rms Magnitude	Volts/Scale Factor D	0 to 32,767
1091	Phase B Voltage, Fundamental Coincident Angle	In 10ths of degrees	0 to 3,599
1092	Phase C Voltage, Fundamental rms Magnitude	Volts/Scale Factor D	0 to 32,767
1093	Phase C Voltage, Fundamental Coincident Angle	In 10ths of degrees	0 to 3,599
1094	Phase A-B Voltage, Fundamental rms Magnitude	Volts/Scale Factor D	0 to 32,767
1095	Phase A-B Voltage, Fundamental Coincident Angle	In 10ths of degrees	0 to 3,599
1096	Phase B-C Voltage, Fundamental rms Magnitude	Volts/Scale Factor D	0 to 32,767
1097	Phase B-C Voltage, Fundamental Coincident Angle	In 10ths of degrees	0 to 3,599
1098	Phase C-A Voltage, Fundamental rms Magnitude	Volts/Scale Factor D	0 to 32,767
1099	Phase C-A Voltage, Fundamental Coincident Angle	In 10ths of degrees	0 to 3,599
1100	Phase A Fundamental Real Power	KW/Scale Factor E	0 to $\pm 32,767$
1101	Phase B Fundamental Real Power	KW/Scale Factor E	0 to $\pm 32,767$

<u>Reg. #</u>	<u>Description</u>	<u>Units</u>	<u>Range</u>
1102	Phase C Fundamental Real Power	KW/Scale Factor E	0 to ±32,767
1103	3-Phase Total Fundamental Real Power	KW/Scale Factor E	0 to ±32,767
1104	Phase A Fundamental Reactive Power	KW/Scale Factor E	0 to ±32,767
1105	Phase B Fundamental Reactive Power	KW/Scale Factor E	0 to ±32,767
1106	Phase C Fundamental Reactive Power	KW/Scale Factor E	0 to ±32,767
1107	3-Phase Total Fundamental Reactive Power	KW/Scale Factor E	0 to ±32,767
1108	Harmonic Factor, Phase A	% in 10ths	0 to 1000
1109	Harmonic Factor, Phase B	% in 10ths	0 to 1000
1110	Harmonic Factor, Phase C	% in 10ths	0 to 1000
1111	Harmonic Factor, 3-Phase Total	% in 10ths	0 to 1000
1112	Harmonic Power, Phase A	KW/Scale	0 to ±32,767
1113	Harmonic Power, Phase B	KW/Scale	0 to ±32,767
1114	Harmonic Power, Phase C	KW/Scale	0 to ±32,767
1115	Harmonic Power, 3-Phase Total	KW/Scale	0 to ±32,767
1117	Phase Rotation: 0=Normal A-B-C, 1=C-B-A	none	0 to 1

REAL TIME METERED VALUES MINIMUM

1200	Minimum update Interval	In 1000ths of a second	0 to 10,000
1201	Minimum Freq.	Hertz/Scale Factor F	2300 to 6700, (50/60)
1202	Minimum Temp.	Degrees Cent.	±10,000 in 100ths
1203	Minimum Current Phase A	Amps/Scale Factor A	0 to 32,767
1204	Minimum Current Phase B	Amps/Scale Factor A	0 to 32,767
1205	Minimum Current Phase C	Amps/Scale Factor A	0 to 32,767
1206	Minimum Current Neutral (I4)	Amps/Scale Factor A	0 to 32,767
1207	Minimum Current Ground (I5)	Amps/Scale Factor A	0 to 32,767
1208	Minimum Current 3 - Phase Average	Amps/Scale Factor A	0 to 32,767
1209	Minimum Current Apparent rms	Amps/Scale Factor A	0 to 32,767
1210	Minimum Current Unbalance, Phase A	Percent in 10ths	0 to ±1000
1211	Minimum Current Unbalance, Phase B	Percent in 10ths	0 to ±1000
1212	Minimum Current Unbalance, Phase C	Percent in 10ths	0 to ±1000
1213	Minimum Current Unbalance Worst	Percent in 10ths	0 to ±1000
1214	Minimum Volt. Phase A to B	Volts/Scale Factor D	0 to 32,767
1215	Minimum Volt. Phase B to C	Volts/Scale Factor D	0 to 32,767
1216	Minimum Vol. Phase C to A	Volts/Scale Factor D	0 to 32,767
1217	Minimum Volt L-L, 3-Phase Average	Volts/Scale Factor D	0 to 32,767
1218	Minimum Volt. Phase A to Neutral	Volts/Scale Factor D	0 to 32,767
1219	Minimum Volt. Phase B to Neutral	Volts/Scale Factor D	0 to 32,767
1220	Minimum Volt. Phase C to Neutral	Volts/Scale Factor D	0 to 32,767
1221	Minimum Volt L-N, 3-Phase Average	Volts/Scale Factor D	0 to 32,767
1222	Minimum Volt Unbal Phase A-B	Percent in 10ths	0 to ±1000
1223	Minimum Volt Unbal Phase B-C	Percent in 10ths	0 to ±1000
1224	Minimum Volt Unbal. Phase C-A	Percent in 10ths	0 to ±1000
1225	Minimum Volt Unbal. L-L Worst	Percent in 10ths	0 to ±1000
1226	Minimum Volt Unbal. Phase A	Percent in 10ths	0 to ±1000
1227	Minimum Volt Unbal. Phase B	Percent in 10ths	0 to ±1000
1228	Minimum Volt Unbal. Phase C	Percent in 10ths	0 to ±1000
1229	Minimum Volt L-N Unbal Worst.	Percent in 10ths	0 to ±1000
1231	Minimum True, Power Factor A	In 1000ths	-100 to +1000 to +100
1232	Minimum True, Power Factor B	In 1000ths	-100 to +1000 to +100
1233	Minimum True, Power Factor C	In 1000ths	-100 to +1000 to +100
1234	Minimum True, Power Factor, 3 Total	In 1000ths	-100 to +1000 to +100
1235	Minimum Displ. Power Factor, A	In 1000ths	-100 to +1000 to +100
1236	Minimum Displ. Power Factor, B	In 1000ths	-100 to +1000 to +100

<u>Reg. #</u>	<u>Description</u>	<u>Units</u>	<u>Range</u>
1237	Minimum Displ. Power Factor, C	In 1000ths	-100 to +1000 to +100
1238	Minimum Displ. Power Factor, 3-phase Total	In 1000ths	-100 to +1000 to +100
1239	Minimum Real Power, Phase A	kW/Scale Factor E	0 to ±32,767
1240	Minimum Real Power, Phase B	kW/Scale Factor E	0 to ±32,767
1241	Minimum Real Power, Phase C	kW/Scale Factor E	0 to ±32,767
1242	Minimum Real Power 3-Phase Total	kW/Scale Factor E	0 to ±32,767
1243	Minimum Reactive Power Phase A	kVAr/Scale Factor E	0 to ±32,767
1244	Minimum Reactive Power Phase B	kVAr/Scale Factor E	0 to ±32,767
1245	Minimum Reactive Power Phase C	kVAr/Scale Factor E	0 to ±32,767
1246	Minimum Reactive Power 3-Phase Total	kVAr/Scale Factor E	0 to ±32,767
1247	Minimum Apparent Power Phase A	kVA/Scale Factor E	0 to +32,767
1248	Minimum Apparent Power Phase B	kVA/Scale Factor E	0 to +32,767
1249	Minimum Apparent Power Phase C	kVA/Scale Factor E	0 to +32,767
1250	Minimum Apparent Power 3-Phase Total	kVA/Scale Factor E	0 to +32,767
1251	Minimum THD Phase B Current	% in 10ths	0 to 32,767
1252	Minimum THD Phase B Current	% in 10ths	0 to 32,767
1253	Minimum THD Phase C Current	% in 10ths	0 to 32,767
1254	Minimum THD Neutral Current	% in 10ths	0 to 32,767
1255	Minimum THD Phase A Voltage	% in 10ths	0 to 32,767
1256	Minimum THD Phase B Voltage	% in 10ths	0 to 32,767
1257	Minimum THD Phase C Voltage	% in 10ths	0 to 32,767
1258	Minimum THD A-B Voltage	% in 10ths	0 to 32,767
1259	Minimum THD B-C Voltage	% in 10ths	0 to 32,767
1260	Minimum THD C-A Voltage	% in 10ths	0 to 32,767
1271	Minimum K-Factor A	In 10ths	0 to 10,000
1272	Minimum K-Factor B	In 10ths	0 to 10,000
1273	Minimum K-Factor C	In 10ths	0 to 10,000

REAL TIME METERED VALUES MAXIMUM

1400	Maximum update Interval	In 1000ths of a second	0 to 10,000
1401	Maximum Freq.	Hertz/Scale Factor F	2300 to 6700, (50/60)
1402	Maximum Temp.	Degrees Cent. in 100ths	-10,000 to +10,000
1403	Maximum Current Phase A	Amps/Scale Factor A	0 to 32,767
1404	Maximum Current Phase B	Amps/Scale Factor A	0 to 32,767
1405	Maximum Current Phase C	Amps/Scale Factor A	0 to 32,767
1406	Maximum Current Neutral (I4)	Amps/Scale Factor B	0 to 32,767
1407	Maximum Current Ground (I5)	Amps/Scale Factor C	0 to 32,767
1408	Maximum Current 3 - Phase Average	Amps/Scale Factor A	0 to 32,767
1409	Maximum Current, Apparent rms	Amps/Scale Factor A	0 to 32,767
1410	Maximum Current Unbalance, Phase A	Percent in 10ths	0 to ±1000
1411	Maximum Current Unbalance, Phase B	Percent in 10ths	0 to ±1000
1412	Maximum Current Unbalance Phase C	Percent in 10ths	0 to ±1000
1413	Maximum Current Unbalance Worst	Percent in 10ths	0 to ±1000
1414	Maximum Voltage Phase A to B	Volts/Scale Factor D	0 to 32,767
1415	Maximum Voltage Phase B to C	Volts/Scale Factor D	0 to 32,767
1416	Maximum Voltage Phase C to A	Volts/Scale Factor D	0 to 32,767
1417	Maximum Volt L-L, 3-Phase Average	Volts/Scale Factor D	0 to 32,767
1418	Maximum Voltage Phase A to Neutral	Volts/Scale Factor D	0 to 32,767
1419	Maximum Voltage Phase B to Neutral	Volts/Scale Factor D	0 to 32,767
1420	Maximum Voltage Phase C to Neutral	Volts/Scale Factor D	0 to 32,767
1421	Maximum Volt L-N, 3-Phase Average	Volts/Scale Factor D	0 to 32,767
1422	Maximum Volt Unbal Phase A-B	Percent in 10ths	0 to ±1000
1423	Maximum Volt Unbal Phase B-C	Percent in 10ths	0 to ±1000

<u>Reg. #</u>	<u>Description</u>	<u>Units</u>	<u>Range</u>
1424	Maximum Volt Unbal. Phase C-A	Percent in 10ths	0 to ±1000
1425	Maximum Volt Unbal. L-L Worst	Percent in 10ths	0 to ±1000
1426	Maximum Volt Unbal. Phase A	Percent in 10ths	0 to ±1000
1427	Maximum Volt Unbal. Phase B	Percent in 10ths	0 to ±1000
1428	Maximum Volt Unbal. Phase C	Percent in 10ths	0 to ±1000
1429	Maximum Volt L-N. Unbal Worst	Percent in 10ths	0 to ±1000
1431	Maximum True, Power Factor A	in 1000ths	-100 to +1000 to +100
1432	Maximum True, Power Factor B	In 1000ths	-100 to +1000 to +100
1433	Maximum True, Power Factor C	In 1000ths	-100 to +1000 to +100
1434	Maximum True, Power Factor 3-Phase Total	In 1000ths	-100 to +1000 to +100
1435	Maximum Displ. Power Factor Phase A	In 1000ths	-100 to +1000 to +100
1436	Maximum Displ. Power Factor, Phase B	In 1000ths	-100 to +1000 to +100
1437	Maximum Displ. Power Factor Phase C	In 1000ths	-100 to +1000 to +100
1438	Maximum Displ. Power Factor 3-Phase Total	Percent	-100 to +1000 to +100
1439	Maximum Real Power Phase A	kW/Scale Factor E	0 to ±32,767
1440	Maximum Real Power Phase B	kW/Scale Factor E	0 to ±32,767
1441	Maximum Real Power Phase C	kW/Scale Factor E	0 to ±32,767
1442	Maximum Real Power 3 Total	kW/Scale Factor E	0 to ±32,767
1443	Maximum Reactive Power Phase A	kVAr/Scale Factor E	0 to ±32,767
1444	Maximum Reactive Power Phase B	kVAr/Scale Factor E	0 to ±32,767
1445	Maximum Reactive Power Phase C	kVAr/Scale Factor E	0 to ±32,767
1446	Maximum Reactive Power 3-Phase Total	kVAr/Scale Factor E	0 to ±32,767
1447	Maximum Apparent Power Phase A	kVA/Scale Factor E	0 to +32,767
1448	Maximum Apparent Power Phase B	kVA/Scale Factor E	0 to +32,767
1449	Maximum Apparent Power Phase C	kVA/Scale Factor E	0 to +32,767
1450	Maximum Apparent Power 3-Phase Total	kVA/Scale Factor E	0 to +32,767
1451	Maximum THD Phase A Current	% in 10ths	0 to 32,767
1452	Maximum THD Phase B Current	% in 10ths	0 to 32,767
1453	Maximum THD Phase C Current	% in 10ths	0 to 32,767
1454	Maximum THD Neutral Current	% in 10ths	0 to 10,000
1455	Maximum THD Phase A Voltage	% in 10ths	0 to 32,767
1456	Maximum THD Phase B Voltage	% in 10ths	0 to 32,767
1457	Maximum THD Phase C Voltage	% in 10ths	0 to 32,767
1458	Maximum THD A-B Voltage	% in 10ths	0 to 32,767
1459	Maximum THD B-C Voltage	% in 10ths	0 to 32,767
1460	Maximum THD C-A Voltage	% in 10ths	0 to 32,767
1471	Maximum K-Factor Phase A	In 10ths	0 to 10,000
1472	Maximum K-Factor Phase B	In 10ths	0 to 10,000
1473	Maximum K-Factor Phase C	In 10ths	0 to 10,000

ENERGY VALUES

Each energy is kept in 4 registers, except incremental which is kept in 3 registers, modulo 10,000 per register

ACCUMULATED ENERGY

1601-1604	Real Energy In 3-Phase Total	WH	0 to 9,999,999,999,999,999
1605-1608	Reactive Energy In 3-Phase Total	VARh	0 to 9,999,999,999,999,999
1609-1612	Real Energy Out 3-Phase Total	WH	0 to 9,999,999,999,999,999
1613-1616	Reactive Energy Out 3-Phase Total	VARh	0 to 9,999,999,999,999,999
1617-1620	Apparent Energy, 3-Phase Total	VAh	0 to 9,999,999,999,999,999
1621-1624	Real Energy Signed/Absolute 3-Phase Total	WH	0 to ±9,999,999,999,999,999
1625-1628	Reactive Energy Signed/Absolute 3-Phase Total	VARh	0 to ±9,999,999,999,999,999

<u>Reg. #</u>	<u>Description</u>	<u>Units</u>	<u>Range</u>
CONDITIONAL ACCUMULATED ENERGY			
1629-1632	Conditional Real Energy In, 3-Phase Total	WH	0 to 9,999,999,999,999,999
1633-1636	Conditional Reactive Energy In 3-Phase Total	VArH	0 to 9,999,999,999,999,999
1637-1640	Conditional Real Energy Out, 3-Phase Total	WH	0 to 9,999,999,999,999,999
1641-1644	Conditional Reactive Energy Out 3-Phase Total	VArH	0 to 9,999,999,999,999,999
1645-1648	Conditional Apparent Energy 3-Phase Total	VAH	0 to 9,999,999,999,999,999

INCREMENTAL ACCUMULATED ENERGY

1649-1651	Incremental Real Energy In, 3-Phase Total	WH	0 to 999,999,999,999
1652-1654	Incremental Reactive Energy In 3-Phase Total	VArH	0 to 999,999,999,999
1655-1657	Incremental Real Energy Out, 3-Phase Total	WH	0 to 999,999,999,999
1658-1660	Incremental Reactive Energy Out 3-Phase Total	VArH	0 to 999,999,999,999
1661-1663	Incremental Apparent Energy 3-Phase Total	VAH	0 to 999,999,999,999

DEMAND VALUES

CURRENT DEMAND

1700	Present Current Demand 3-Phase Average	Amps/Scale Factor A	0 to 32,767
1701	Present Current Demand Phase A	Amps/Scale Factor A	0 to 32,767
1702	Present Current Demand Phase B	Amps/Scale Factor A	0 to 32,767
1703	Present Current Demand Phase C	Amps/Scale Factor A	0 to 32,767
1704	Present Current Demand Neutral	Amps/Scale Factor A	0 to 32,767
1705	Thermal K-Factor Demand, Phase A	In 10ths	0 to 10,000
1706	Thermal K-Factor Demand, Phase B	In 10ths	0 to 10,000
1707	Thermal K-Factor Demand, Phase C	In 10ths	0 to 10,000
1708	Peak Current Demand 3-Phase Average	Amps/Scale Factor A	0 to 32,767
1709	Peak Current Demand Phase A	Amps/Scale Factor A	0 to 32,767
1710	Peak Current Demand Phase B	Amps/Scale Factor A	0 to 32,767
1711	Peak Current Demand Phase C	Amps/Scale Factor A	0 to 32,767
1712	Peak Current Demand Neutral	Amps/Scale Factor A	0 to 32,767
1713	K-Factor Demand Phase A Coincident Peak Product	In 10ths	0 to 10,000
1714	Current Demand Phase A Coincident Peak Product	Amps/Scale Factor A	0 to 32,767
1715	K-Factor Demand Phase B Coincident Peak Product	In 10ths	0 to 10,000
1716	Current Demand Phase B Coincident Peak Product	Amps/Scale Factor A	0 to 32,767
1717	K-Factor Demand Phase C Coincident Peak Product	In 10ths	0 to 10,000
1718	Current Demand Phase C Coincident Peak Product	Amps/Scale Factor A	0 to 32,767

POWER DEMAND

Reactive Demand may be calculated using either the fundamental only (default), or total harmonics (user selectable).

1730	Average Power Factor Over Interval	Percent in 1000ths	-100 to 1000 to +100
1731	Present Real Power, Demand, 3-Phase Total	kW/Scale Factor E	0 to ±32,767
1732	Present Reactive Power, Demand, 3 Phase Total	kVAr/Scale Factor E	0 to ±32,767
1733	Present Apparent Power Demand 3-Phase Total	kVA/Scale Factor E	0 to 32,767
1734	Peak Real Power Demand 3-Phase Total	kW/Scale Factor E	0 to ±32,767
1735	Average Power Factor for Peak Real	Percent in 1000ths	-100 to 1000 to +100
1736	Reactive Power Demand for Peak Real	kVAr/Scale Factor E	0 to ±32,767
1737	Apparent Power Demand for Peak Real	kVA/Scale Factor E	0 to 32,767
1738	Peak Reactive Power Demand, 3-Phase Total	kVAr/Scale Factor E	0 to ±32,767
1739	Average Reactive Power Factor for Peak Reactive	Percent in 1000ths	-100 to 1000 to +100
1740	Real Power Demand for Peak Reactive	kW/Scale Factor E	0 to ±32,767

Reg. #	Description	Units	Range
1741	Apparent Power Demand for Peak Reactive	kVA/Scale Factor E	0 to 32,767
1742	Peak Apparent Power Demand, 3-Phase Total	kVA/Scale Factor E	0 to 32,767
1743	Average Apparent Power Factor for Peak Apparent	Percent in 1000ths	-100 to 1000 to +100
1744	Real Power Demand for Peak Apparent	kW/Scale Factor E	0 to ±32,767
1745	Reactive Power Demand for Peak Apparent	kVAr/Scale Factor E	0 to ±32,767
1746	Predicted Real Power Demand, 3 Phase Total	kW/Scale Factor E	0 to 32,767
1747	Predicted Reactive Power Demand, 3-Phase Total	kVAr/Scale Factor E	0 to 32,767
1748	Predicted Apparent Power Demand, 3-Phase Total	kVA/Scale Factor E	0 to 32,767
1749	Maximum Sub-Interval Real Power 3-Phase Demand Over Last Inc. Energy Interval	kW/Scale Factor E	0 to 32,767
1750	Maximum Sub-Interval Reactive Power 3-Phase Demand Over Last Inc. Energy Interval	kVAr/Scale Factor E	0 to 32,767
1751	Maximum Sub-Interval Apparent Power 3-Phase Demand Over Last Inc. Energy Interval	kVA/Scale Factor E	0 to 32,767
1752	Time Remaining in Sub Demand Interval	Seconds	0 to 3600

DATE/TIME (Compressed, 3 register format)

The date and time in registers 1800–1802 are stored as follows. Other dates and times (through register 1877) are stored in an identical manner.

*Register 1800, Month (byte 1) = 1–12, Day (byte 2) = 1–31
 Register 1801, Year (byte 1) = 0–199, Hour (byte 2) = 0–23,
 Register 1802, Minutes (byte 1) = 0–59, Seconds (byte 2) = 0–59
 The year is zero based on the year 1900 in anticipation of the 21st century, (e.g. 1989 would be represented as 89 and 2009 would be represented as 109).

1800–1802	Last Restart Date/Time	Month, Day, Yr., Hr., Min., Sec.	*See Above
1803–1805	Date/Time Demand of Peak Current Phase A	Month, Day, Yr., Hr., Min., Sec.	Same as Regs.# 1800–1802
1806–1808	Date/Time Demand of Peak Current Phase B	Month, Day, Yr., Hr., Min., Sec.	Same as Regs.# 1800–1802
1809–1811	Date/Time Demand of Peak Current Phase C	Month, Day, Yr., Hr., Min., Sec.	Same as Regs.# 1800–1802
1812–1814	Date/Time of Peak Demand (Average Real Power)	Month, Day, Yr., Hr., Min., Sec.	Same as Regs.# 1800–1802
1815–1817	Date/Time of Last Reset of Peak Demand Current	Month, Day, Yr., Hr., Min., Sec.	Same as Regs.# 1800–1802
1818–1820	Date/Time of last Min/Max Clear of Instantaneous Values	Month, Day, Yr., Hr., Min., Sec.	Same as Regs.# 1800–1802
1821–1823	Date/Time of Last Write to Circuit Tracker™ Setpoint Register	Month, Day, Yr., Hr., Min., Sec.	Same as Regs.# 1800–1802
1824–1826	Date/Time when Peak Demand was last cleared	Month, Day, Yr., Hr., Min., Sec.	Same as Regs.# 1800–1802

<u>Reg. #</u>	<u>Description</u>	<u>Units</u>	<u>Range</u>
1827-1829	Date/Time When Accumulated Energy Last Cleared	Month, Day, Yr., Hr., Min., Sec.	Same as Regs.# 1800-1802
1830-1832	Date/Time When Control Power Failed Last	Month, Day, Yr., Hr., Min., Sec.	Same as Regs.# 1800-1802
1833-1835	Date/Time When Level 1 Energy Mgmt. Setpt. Alarm Period Was Last Entered	Month, Day, Yr., Hr., Min., Sec.	Same as Regs.# 1800-1802
1836-1838	Date/Time When Level 2 Energy Mgmt. Setpt. Alarm Period Was Last Entered	Month, Day, Yr., Hr., Min., Sec.	Same as Regs.# 1800-1802
1839-1841	Date/Time When Level 3 Energy Mgmt. Setpt. Alarm Period Was Last Entered	Month, Day, Yr., Hr., Min., Sec.	Same as Regs.# 1800-1802
1842-1844	Present/Set Date/Time	Month, Day, Yr., Hr., Min., Sec.	Same as Regs.# 1800-1802
1845-1847	Date/Time of Calibration	Month, Day, Yr., Hr., Min., Sec.	Same as Regs.# 1800-1802
1848-1850	Date/Time of Peak K-Factor Demand A Product	Month, Day, Yr., Hr., Min., Sec.	Same as Regs.# 1800-1802
1851-1853	Date/Time of Peak K-Factor Demand B Product	Month, Day, Yr., Hr., Min., Sec.	Same as Regs.# 1800-1802
1854-1856	Date/Time of Peak K-Factor Demand C Product	Month, Day, Yr., Hr., Min., Sec.	Same as Regs.# 1800-1802
1857-1859	Date/Time of Peak Reactive Demand Power	Month, Day, Yr., Hr., Min., Sec.	Same as Regs.# 1800-1802
1860-1862	Date/Time of Peak Apparent Demand Power	Month, Day, Yr., Hr., Min., Sec.	Same as Regs.# 1800-1802
1863-1865	Incremental Energy Start Time of Day	Month, Day, Yr., Hr., Min., Sec.	Same as Regs.# 1800-1802
1866-1868	Date/Time when Conditional Energy Last Cleared	Month, Day, Yr., Hr., Min., Sec.	Same as Regs.# 1800-1802
1869-1871	Incremental Energy Last Update Date/Time	Month, Day, Yr., Hr., Min., Sec.	Same as Regs.# 1800-1802
1872-1874	Date/Time of Peak 3-Phase Avg Current Demand	Month, Day, Yr., Hr., Min., Sec.	Same as Regs.# 1800-1802
1875-1877	Date/Time of Peak Neutral Current Demand	Month, Day, Yr., Hr., Min., Sec.	Same as Regs. # 1800-1802

<u>Reg. #</u>	<u>Description</u>	<u>Units</u>	<u>Range</u>
DATE/TIME Expanded (6 registers)			
The date and time in registers 700–705 are stored as follows. Other dates and times through register 795 are stored in an identical manner.			
*Seconds (Reg.. 700) = 0–59, Minutes (Reg.. 701) = 0–59, Hours (Reg.. 702) = 0–23, Day (Reg.. 703) 1–31, Month (Reg.. 704) = 1–12, Year (Reg.. 705) = 1900–2099 The date and time are mapped from CM Registers 1800–1802.			
[700–705]	Last Restart Date/Time	Sec, Min, Hour Day, Month, Yr.	*See above
[706–711]	Date/Time Demand of Peak Current Phase A	Sec, Min, Hour Day, Month, Yr.	Same as Regs. # 700–705
[712–717]	Date/Time Demand of Peak Current Phase B	Sec, Min, Hour Day, Month, Yr.	Same as Regs. # 700–705
[718–723]	Date/Time Demand of Peak Current Phase C	Sec, Min, Hour Day, Month, Yr.	Same as Regs. # 700–705
[724–729]	Date/Time of Peak Demand (Average Real Power)	Sec, Min, Hour Day, Month, Yr.	Same as Regs. # 700–705
[730–735]	Date/Time of Last Reset of Peak Demand Current	Sec, Min, Hour Day, Month, Yr.	Same as Regs. # 700–705
[736–741]	Date/Time of last Min/Max Clear of Instantaneous Values	Sec, Min, Hour Day, Month, Yr.	Same as Regs. # 700–705
[742–747]	Date/Time of Last Write to Circuit Tracker™ Setpoint Register	Sec, Min, Hour Day, Month, Yr.	Same as Regs. # 700–705
[748–753]	Date/Time when Peak Demand was last cleared	Sec, Min, Hour Day, Month, Yr.	Same as Regs. # 700–705
[754–759]	Date/Time when Accumulated Energy Last Cleared	Sec, Min, Hour Day, Month, Yr.	Same as Regs. # 700–705
[760–765]	Date/Time when Control Power Failed Last	Day, Month, Yr. Sec, Min, Hour	Regs. # 700–705 Same as
[766–771]	Date/Time When Level 1 Energy Mgmt. Setpt. Alarm Period was Last Entered	Sec, Min, Hour Day, Month, Yr.	Same as Regs. # 700–705
[772–777]	Date/Time When Level 2 Energy Mgmt. Setpt. Alarm Period was Last Entered	Sec, Min, Hour Day, Month, Yr.	Same as Regs. # 700–705
[778–783]	Date/Time When Level 3 Energy Mgmt. Setpt. Alarm Period was Last Entered	Sec, Min, Hour Day, Month, Yr.	Same as Regs. # 700–705
[784–789]	Present/Set Date/Time	Sec, Min, Hour Day, Month, Yr.	Same as Regs. # 700–705
[790–795]	Date/Time of Calibration	Sec, Min, Hour Day, Month, Yr.	Same as Regs. # 700–705

<u>Reg. #</u>	<u>Description</u>	<u>Units</u>	<u>Range</u>
STATUS INPUTS			
2400	Input Status	None	0000 to 00FF Hex
2401	Input Conditional Energy Control	None	0000 to 00FF Hex
2402-2403	Input 1 Label	None	Alpha-Numeric 4 Chars.
2404-2505	Input 1 Count	Counts	0 to 99,999,999
2406	Input 1 On-Timer	Seconds	0 to 32,767
2407-2408	Input 2 Label	None	Alpha-Numeric 4 Chars.
2409-2410	Input 2 Count	Counts	0 to 99,999,999
2411	Input 2 On-Timer	Seconds	0 to 32,767
2412-2413	Input 3 Label	None	Alpha-Numeric 4 Chars.
2414-2415	Input 3 Count	Counts	0 to 99,999,999
2416	Input 3 On-Timer	Seconds	0 to 32,767
2417-2418	Input 4 Label	None	Alpha-Numeric 4 Chars.
2419-2420	Input 4 Count	Counts	0 to 99,999,999
2421	Input 4 On-Timer	Seconds	0 to 32,767
2422-2423	Input 5 Label	None	Alpha-Numeric 4 Chars.
2424-2425	Input 5 Count	Counts	0 to 99,999,999
2426	Input 5 On-Timer	Seconds	0 to 32,767
2427-2428	Input 6 Label	None	Alpha-Numeric 4 Chars.
2429-2430	Input 6 Count	Counts	0 to 99,999,999
2431	Input 6 On-Timer	Seconds	0 to 32,767
2432-2433	Input 7 Label	None	Alpha-Numeric 4 Chars.
2434-2435	Input 7 Count	Counts	0 to 99,999,999
2436	Input 7 On-Timer	Seconds	0 to 32,767
2437-2438	Input 8 Label	None	Alpha-Numeric 4 Chars.
2439-2440	Input 8 Count	Counts	0 to 99,999,999
2441	Input 8 On-Timer	Seconds	0 to 32,767

<u>Reg. #</u>	<u>Name</u>	<u>Units</u>	<u>Range</u>	<u>Description</u>
<u>KYZ and RELAY OUTPUTS</u>				
2500	Output Status	None	0000 to 00FF Hex	Bit Map of the states of the Outputs. A 1=On, a 0=Off. Bit 1 represents the KYZ Output, bits 2-8 represent relays R1-R7, respectively. Register 235 is ghosted as Read Only and does not provide control.
2501	Output Control State Bit Mask	None	0000 to FFFF Hex	Bit Map indicating active Relay Control states. The lower byte indicates the status of internal/external control. A 1 = Relay Control is under internal control and a 0 = Relay Control is under external control. The upper byte indicates the status of override control. A 1 = Relay Control is in override and a 0 = Relay Control is not in override. For each byte, Bit 1 represents the KYZ pulse output, and bits 2-4 represent relays R1-R3, respectively.
2502-2503	KYZ Output Label	None	Alpha-Numeric 4 Chars. (2 Regs.)	Label for KYZ output.
2504	KYZ Output Mode Reg.	None	0 to 4	KYZ Output Mode Register: 0 = Normal, 1=Latched, 2 = Timed, 3 = Absolute kWH pulse, 4 = Absolute kVArH pulse, 5 = kVAH pulse 6 = kWH in pulse, 7 = kVar in pulse, 8 = kWH out pulse, 9 = kVAr out pulse
2505	KYZ Output Parameter Register	Seconds	0 to 32,767	This register specifies the time output 1 is to remain closed for timed and fail-safe modes.
2506	KYZ Output kWH, kVArH or kVAH /Pulse Register	kWH/Pulse or kVArH/Pulse or kVAH/Pulse In 10ths	0 to 32,767	This register specifies the kWH, kVArH or kVAH per pulse for the KYZ output when in those modes.
2507-2508	Relay R1 Label	None	Alpha-Numeric 4 Chars. (2 Regs.)	Label for relay R1.
2509	Relay R1 Mode Reg.	None	0 to 4	Relay R1 Mode Register: 0 = Normal, 1=Latched, 2 = Timed, 3 = Absolute kWH pulse, 4 = Absolute kVArH pulse, 5 = kVAH pulse 6 = kWH in pulse, 7 = kVar in pulse, 8 = kWH out pulse, 9 = kVAr out pulse
2510	Relay R1 Parameter Register	Seconds	0 to 32,767	This register specifies the time relay R1 is to remain closed for timed mode.
2511	Relay R1 kWH, kVArH or kVAH/ Pulse Register	kWH/Pulse or kVArH/Pulse or kVAH/Pulse In 10ths	0 to 32,767	This register specifies the kWH, kVArH or kVAH per pulse for relay R1 when in those modes.

<u>Reg. #</u>	<u>Name</u>	<u>Units</u>	<u>Range</u>	<u>Description</u>
2512-2513	Relay R2 Label	None	Alpha-Numeric 4 Chars. (2 Regs.)	Label for relay R2.
2514	Relay R2 Mode Reg.	None	0 to 4	Relay R2 Mode Register: 0 = Normal, 1=Latched, 2 = Timed, 3 = Absolute kWh pulse, 4 = Absolute kVArH pulse, 5 = kVAH pulse 6 = kWh in pulse, 7 = kVar in pulse, 8 = kWh out pulse, 9 = kVAr out pulse
2515	Relay R2 Parameter Register	Seconds	0 to 32,767	This register specifies the time relay R2 is to remain closed for timed mode.
2516	Relay R2 kWh, kVArH or kVAH/ Pulse Register	kWh/Pulse or kVArH/Pulse or kVAH/Pulse In 10ths	0 to 32,767	This register specifies the kWh, kVArH or kVAH per pulse for relay R2 when in those modes.
2517-2518	Relay R3 Label	None	Alpha-Numeric 4 Chars. (2 Regs.)	Label for relay R3.
2519	Relay R3 Mode Reg.	None	0 to 4	Relay R3 Mode Register: 0 = Normal, 1=Latched, 2 = Timed, 3 = Absolute kWh pulse, 4 = Absolute kVArH pulse, 5 = kVAH pulse 6 = kWh in pulse, 7 = kVar in pulse, 8 = kWh out pulse, 9 = kVAr out pulse
2520	Relay R3 Parameter Register	Seconds	0 to 32,767	This register specifies the time relay R3 is to remain closed for timed mode.
2521	Relay R3 kWh, kVArH or kVAH /Pulse Register	kWh/Pulse or kVArH/Pulse or kVAH/Pulse In 10ths	0 to 32,767	This register specifies the kWh, kVArH or kVAH per pulse for relay R3 when in those modes.

<u>Reg. #</u>	<u>Description</u>	<u>Units</u>	<u>Range</u>
<u>CIRCUIT MONITOR CONFIGURATION VALUES</u>			
2002	CT Ratio 3-Phase Primary Ratio Term	None	1 to 32,767
2003	CT Ratio 3-Phase Secondary Ratio Term	None	1 to 5
2004	CT Ratio Neutral Primary Ratio Term	None	1 to 32,767
2005	CT Ratio Neutral Secondary Ratio Term	None	1 to 5
2006	PT Ratio 3-Phase Primary Ratio Term	None	1 to 32,767
2007	PT Ratio 3-Phase Primary Scale Factor	None	0 to 2
2008	PT Ratio 3-Phase Secondary Ratio Term	None	1 to 600
2009	CT Ratio Correction Factors Phase A	In 10,000ths	5,000 - 20,000
2010	CT Ratio Correction Factors Phase B	In 10,000ths	5,000 - 20,000
2011	CT Ratio Correction Factors Phase C	In 10,000ths	5,000 - 20,000
2012	CT Ratio Correction Factors Neutral /Ground	In 10,000ths	5,000 - 20,000
2013	PT Ratio Correction Factors Phase A	In 10,000ths	5,000 - 20,000
2014	PT Ratio Correction Factors Phase B	In 10,000ths	5,000 - 20,000
2015	PT Ratio Correction Factors Phase C	In 10,000ths	5,000 - 20,000
2016	Nominal System Frequency		

<u>Reg. #</u>	<u>Name</u>	<u>Units</u>	<u>Range</u>	<u>Description</u>
2020	Scale Group A: Ammeter Per Phase	None	-2 to 1	Scale Group A: Ammeter Per Phase -2 = scale by 0.01 -1 = scale by 0.10 0 = scale by 1.00 (default) 1 = scale by 10.0
2021	Scale Group B: Ammeter Neutral	None	-2 to 1	Scale Group B: Ammeter Neutral -2 = scale by 0.01 -1 = scale by 0.10 0 = scale by 1.00 (default) 1 = scale by 10.0
2022	Scale Group C: Ammeter Ground	None	-2 to 1	Scale Group C: Ammeter Ground -2 = scale by 0.01 -1 = scale by 0.10 0 = scale by 1.00 (default) 1 = scale by 10.0
2023	Scale Group D: Voltmeter	None	-1 to 2	Scale Group D: Voltmeter -1 = scale by 0.10 0 = scale by 1.00 (default) 1 = scale by 10.0 2 = scale by 100.
2024	Scale Group E: kwattmeter, kVarmeter, kVa	None	-3 to 3	Scale Group E: kWattmeter, kVarmeter, kVA -3 = scale by .001 -2 = scale by 0.01 -1 = scale by 0.10 0 = scale by 1.00 (default) 1 = scale by 10.0 2 = scale by 100. 3 = scale by 1000 4 = scale by 10,000 5 = scale by 100,000
2025	Scale Group F: Frequency	None	-1 to 2	Scale Group F: Frequency (Determined by CM) -2 = scale by 0.01 (default) -1 = scale by 0.10

<u>Reg. #</u>	<u>Description</u>	<u>Units</u>	<u>Range</u>
2028	Password	None	0 to +/-32,767
2029	Display Setup Password	None	0 to +/-32,767
2040-2041	CM Label	None	Any Valid Alpha-Numeric
2042-2049	CM Nameplate	None	Any Valid Alpha-Numeric
2077	Power Demand Interval	Minutes	0 to 60 @5min. Multiples
2078	Power Demand Sub-Interval	Minutes	0 to 60 @5min. Multiples
2079	Current Demand K-Factor Demand Interval in minutes	Minutes	0 to 60 @5min. Multiples

<u>Reg. #</u>	<u>Name</u>	<u>Units</u>	<u>Range</u>	<u>Description</u>
2080	Energy Accum. Mode Selections Bit map	None	0 or 1	<p>Circuit Monitor Energy Accumulation Mode Selections Bit Map. Bit 1 indicates real & reactive energy accumulation method:</p> <ul style="list-style-type: none"> a 0 indicates absolute a 1 indicates signed
2081	Operating Mode Selections Bit map	None	0 to 7F	<p>Circuit Monitor Operating Mode Selections Bit map</p> <ul style="list-style-type: none"> bit 1 indicates real & reactive energy accumulation method: <ul style="list-style-type: none"> a 0 indicates absolute (default) a 1 indicates signed bit 2 indicates Reactive Energy and Demand accumulation method: <ul style="list-style-type: none"> a 0 specifies fundamental only (default) a 1 specifies to include harmonic cross products (displacement&distortion) bit 3 indicates VAR/PF sign convention: <ul style="list-style-type: none"> a 0 indicates CM1 convention (default) a 1 indicates alternate convention bit 4 indicates Demand Power calculation method: <ul style="list-style-type: none"> a 0 indicates Thermal Demand (default) a 1 indicates a Block/Rolling Interval Demand bit 5 indicates external power demand synch. driver source if applicable: <ul style="list-style-type: none"> a 0 Specifies Input 1 as the source (default) a 1 Specifies Command Interface as the source bit 6 indicates which mechanism controls cond. energy <ul style="list-style-type: none"> a 0 indicates status inputs (default) a 1 indicates command I/F bit 7 indicates status of conditional energy accumulation: <ul style="list-style-type: none"> a 0 indicates Cond Energy Accum is off (default) a 1 indicates Cond Energy Accum is on bit 8 is unused bit 9 indicates status of Unit #1 response to enquire <ul style="list-style-type: none"> a 0 indicates response is enabled (default) a 1 indicates response is disabled bit 10 indicates whether front comm port is enabled <ul style="list-style-type: none"> a 0 indicates front comm port is enabled (default) a 1 indicates front comm port is disabled bit 11 indicates whether front panel setup is enabled <ul style="list-style-type: none"> a 0 indicates front panel setup is enabled (default) a 1 indicates front panel setup is disabled bit 12 indicates status of log and wfc files master enable <ul style="list-style-type: none"> a 0 indicates files are enabled (default) a 1 indicates files are disabled <p>All other bits are unused.</p>

CIRCUIT MONITOR UTILITY REGISTERS

6800–6999	Utility Registers	None	0 to +/-32,767	<p>These read/write registers can be used by the application programmer as required. They are saved in non-volatile memory when the Circuit Monitor loses control power.</p>
-----------	-------------------	------	----------------	--

<u>Reg. #</u>	<u>Description</u>
5780	Event Counter No. 1
5781	Event Counter No. 2
5782	Event Counter No. 3
5783	Event Counter No. 4
5784	Event Counter No. 5
5785	Event Counter No. 6
5786	Event Counter No. 7
5787	Event Counter No. 8
5788	Event Counter No. 9
5789	Event Counter No. 10
5790	Event Counter No. 11
5791	Event Counter No. 12
5792	Event Counter No. 13
5793	Event Counter No. 14
5794	Event Counter No. 15
5795	Event Counter No. 16
5796	Event Counter No. 17
5797	Event Counter No. 18
5798	Event Counter No. 19
5799	Event Counter No. 20
5800	Event Counter No. 21
5801	Event Counter No. 22
5802	Event Counter No. 23
5803	Event Counter No. 23
5804	Event Counter No. 25
5805	Event Counter No. 26
5806	Event Counter No. 27
5807	Event Counter No. 28
5808	Event Counter No. 29
5809	Event Counter No. 30
5810	Event Counter No. 31
5811	Event Counter No. 32
5812	Event Counter No. 33
5813	Event Counter No. 34
5814	Event Counter No. 35
5815	Event Counter No. 36
5816	Event Counter No. 37
5817	Event Counter No. 38
5818	Event Counter No. 39
5819	Event Counter No. 40
5820	Event Counter No. 41
5821	Event Counter No. 42
5822	Event Counter No. 43
5823	Event Counter No. 44
5824	Event Counter No. 45
5825	Event Counter No. 46
5826	Event Counter No. 47
5827	Event Counter No. 48
5828	Event Counter No. 49
5829	Event Counter No. 50
5830	Event Counter No. 51
5831	Event Counter No. 52
5832	Event Counter No. 53
5833	Event Counter No. 54

<u>Reg. #</u>	<u>Description</u>
5834	Event Counter No. 55
5835	Event Counter No. 56
5836	Event Counter No. 57
5837	Event Counter No. 58
5838	Event Counter No. 59
5839	Event Counter No. 60
5840	Event Counter No. 61
5841	Event Counter No. 62
5842	Event Counter No. 63
5843	Event Counter No. 64
5844	Event Counter No. 65
5845	Event Counter No. 66
5846	Event Counter No. 67
5847	Event Counter No. 68
5848	Event Counter No. 69
5849	Event Counter No. 70
5850	Event Counter No. 71
5851	Event Counter No. 72
5852	Event Counter No. 73
5853	Event Counter No. 74
5854	Event Counter No. 75
5855	Event Counter No. 76
5856	Event Counter No. 77
5857	Event Counter No. 78
5858	Event Counter No. 79
5859	Event Counter No. 80
5860	Event Counter No. 81
5861	Event Counter No. 82
5862	Event Counter No. 83
5863	Event Counter No. 84
5864	Event Counter No. 85
5865	Event Counter No. 86
5866	Event Counter No. 87
5867	Event Counter No. 88
5868	Event Counter No. 89
5869	Event Counter No. 90
5870	Event Counter No. 91
5871	Event Counter No. 92
5872	Event Counter No. 93
5873	Event Counter No. 94
5874	Event Counter No. 95
5875	Event Counter No. 96
5876	Event Counter No. 97
5877	Event Counter No. 98
5878	Event Counter No. 99
5879	Event Counter No. 100
5880	Event Counter No. 101
5881	Event Counter No. 102
5882	Event Counter No. 103
5883	Event Counter No. 104
5884	Event Counter No. 105
5885	Event Counter No. 106
5886	Event Counter No. 107
5887	Event Counter No. 108

<u>Reg. #</u>	<u>Description</u>
5888	Event Counter No. 109
5889	Event Counter No. 110
5890	Event Counter No. 111
5891	Event Counter No. 112
5892	Event Counter No. 113
5893	Event Counter No. 114
5894	Event Counter No. 115
5895	Event Counter No. 116
5896	Event Counter No. 117
5897	Event Counter No. 118
5898	Event Counter No. 119
5899	Event Counter No. 120

APPENDIX F—SPECIFICATIONS

Metering Specifications

Current Inputs (Each Channel)	
Current Range	0–7.0A ac
Nominal Current	5A ac
Voltage Inputs (Each Channel)	
Voltage Range	0–180V ac
Nominal Voltage (typical)	120 Vac
Frequency Range	23 to 65 Hz
Harmonic Response—Phase Voltages and Currents	
Frequency 23 Hz to 67 Hz	31st Harmonic
Data Update Rate	1 second typical
Accuracy (CM-2150 and higher)	
Current ^①	±0.15% reading + 0.05% full scale
Voltage	±0.15% reading + 0.05% full scale
Power	±0.30% reading + 0.05% full scale
True Power Factor	±1% (0.5 lag to 0.5 lead)
Displacement Power Factor	±1% (0.5 lag to 0.5 lead)
Energy	±0.30%
Demand	±0.30%
Frequency 50/60 Hz	±0.01 Hz
Temperature (Unit Temperature –25°C to 75°C)	±1°C
Time of Day Clock (At 25°C)	±1.5 second in 24 hours
THD	1.0%
K-Factor	1.0%
Crest Factor	1.0%
Accuracy (CM-2050 only)	
Current ^①	±0.5% reading + 0.25% full scale
Voltage	±0.5% reading + 0.25% full scale
Power	±1.0% reading + 0.25% full scale
True Power Factor	±1% full scale
Displacement Power Factor	±1% full scale
Energy and Demand	±0.5% reading above 50% full scale ±1.0% reading above 20% full scale
Frequency 50/60 Hz	±0.05 Hz
Temperature (Unit Temperature –25°C to 75°C)	±1°C
Time of Day Clock (At 25°C)	±1.5 second in 24 hours
THD	2.0%
K-Factor	2.0%
Crest Factor	2.0%

^①Any CT secondary currents less than 20 mA are reported as zero.

APPENDIX G—CALCULATING LOG FILE SIZES

This appendix tells how to calculate the size of log files. To make sure that the log files you've set up will fit in the available logging memory, calculate the size of each event log, data log, waveform capture log, and 12-cycle event capture log using the instructions below. Then sum all log files to find the total space required. The total space required must be smaller than the numbers listed below:

- CM-2150 and CM-2250. Sum of event log file and all data log files must be smaller than 6144.
- CM-2350 and CM-2450. Sum of event log file, waveform capture log file, 12-cycle event capture, and all data log files must be smaller than 51,200.

Calculating the Size of the Event Log File

1. Multiply the maximum number of events by 8. This is the total size of the file. 1. _____

Calculating the Size of a Data Log File (Do this for each data log file)

1. Multiply the number of cumulative energy readings by 4. 1. _____
2. Multiply the number of incremental energy readings by 3. 2. _____
3. Enter the number of non-energy meter readings. 3. _____
4. Add lines 1, 2, and 3. 4. _____
5. Add 3 to the value on line 4. (For date/time of each entry.) 5. _____
6. Multiply line 5 by the maximum number of entries in the log file. This is the total size of the file. 6. _____

Calculating the Size of the Waveform Capture Log File

1. Multiply the maximum number of waveform captures by 2,560. This is the total size of the file. 1. _____

Calculating the Size of the 12-Cycle Event Capture Log File

1. Multiply the maximum number of 12-cycle event captures by 6,400. This is the total size of the file. 1. _____

APPENDIX H—INSTALLING TERMINAL STRIP COVERS

The hardware kit provided with the Circuit Monitor includes several grey protective terminal strip covers. After wiring the Circuit Monitor, install these terminal strip covers for protection.

Figure H-1 illustrates terminal strip cover installation. Refer to this figure when completing the procedure below.

To install the terminal strip covers, complete the following steps:

1. Bend the terminal strip covers at the crease so they form a right angle.
2. Install each terminal strip cover using two #8-32 SEMS screws, provided in the Circuit Monitor hardware kit.

Be certain to orient the covers so that you can route wires outward. Wires should be routed outward to provide room for future addition of optional modules.

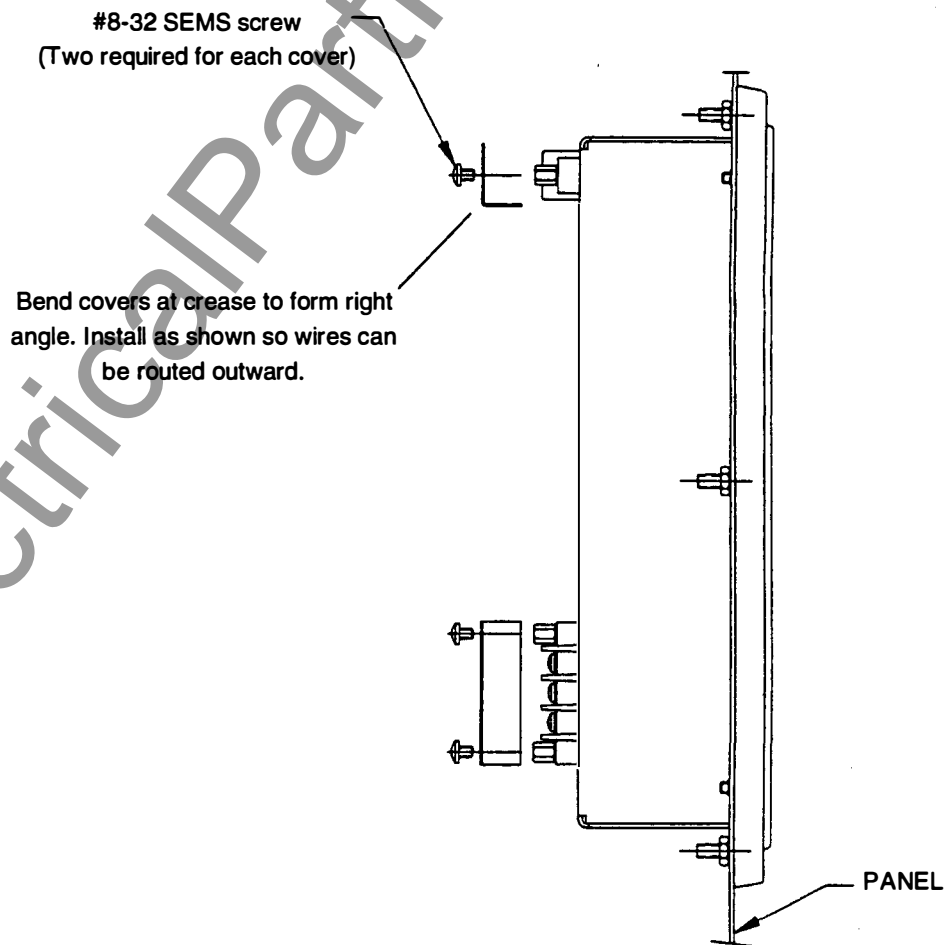

Figure H-1: Installing Terminal Strip Covers

APPENDIX I—ALARM SETUP INFORMATION

The Circuit Monitor is designed to handle a wide range of metering requirements. In order to handle very large and very small metering values the Circuit Monitor uses scale factors to act as multipliers. These scale factors range from .001 up to 1000 and are expressed at powers of 10—for example, $0.001 = 10^{-3}$. These scale factors are necessary because the Circuit Monitor stores data in registers which are limited to integer values between -32767 and +32767. When a value is either larger than 32767, or is a non-integer, it is expressed as an integer in the range of ± 32767 associated with a multiplier in the range of 10^{-3} to 10^3 . For more information on scale factors see **Setting Scale Factors for Extended Metering Ranges** in Chapter 12.

When POWERLOGIC application software is used to set up alarms, it automatically handles the scaling of pickup and dropout setpoints.

When alarm setup is performed from the Circuit Monitor's front panel, the user must:

- determine how the corresponding metering value is scaled, and
- take the scale factor into account when entering alarm pickup and dropout settings.

Pickup and dropout settings must be integer values in the range of -32,767 to +32,767. For example, to set up an under voltage alarm for a 138 KV nominal system the user must decide upon a setpoint value, and then convert it into an integer between -32,767 and +32,767. If the under voltage setpoint were 125,000 V, this would typically be converted to 12500×10 and entered as a setpoint of 12500.

SCALING ALARM SETPOINTS

This section is for users who do not have POWERLOGIC software and must setup alarms from the Circuit Monitor front panel. It tells how to properly scale alarm setpoints.

The Circuit Monitor is equipped with a 6-digit LED display and a two LED's to indicate "Kilo" or "Mega" units, when applicable. When determining the proper scaling of an alarm setpoint first view the corresponding metering value. For example, for an Over Current Phase A alarm, view the Phase A Current. Observe the location of the decimal point in the displayed value and determine if either the "Kilo" or "Mega" light is turned on. This reading can be used to determine the scaling required for alarm setpoints.

The location of the decimal point in the displayed quantity indicates the resolution that is available on this metering quantity. There can be up to 3 digits to the right of the decimal point, indicating whether the quantity is stored in a register as thousandths, hundredths, tenths, or units. The "Kilo" or "Mega" LED indicates the engineering units—Kilowatts or Megawatts—that are applied to the quantity. The alarm setpoint value must use the same resolution as shown in the display.

For example, consider a power factor alarm. If the 3-phase average power factor is 1.000—meaning that the power factor is stored in thousandths—enter the alarm setpoints as integer values in thousandths. Therefore, to define a power factor setpoint of 0.85 lagging, enter -850 (the “-” sign indicates lag).

For another example, consider a Phase A-B Voltage Unbalance alarm. If the V_{A-B} reading is displayed as 138.00 with the Kilo LED turned on, then enter the setpoints in hundredths of kilovolts. Therefore, to define a setpoint of 125,000 volts, enter 12,500 (hundredths of KV). To arrive at this value, first convert 125,000 volts to 125.00 kilovolts; then multiply by 100.

ALARM CONDITIONS AND ALARM CODES

This section lists the Circuit Monitor’s predefined alarm conditions. For each alarm condition, the following information is provided.

- Alarm No.** A code number used to refer to individual alarms
- Alarm Description** A brief description of the alarm condition
- Test Register** The register number that contains the value (where applicable) that is used as the basis for a comparison to alarm pickup and dropout settings.
- Units** The units that apply to the pickup and dropout settings.
- Scale Group** The Scale Group that applies to the test register’s metering value (A-F). For a description of Scale Groups, see **Setting Scale Factors for Extended Metering Ranges** in Chapter 12.
- Alarm Type** A reference to a definition providing details on the operation and configuration of the alarm. See **Alarm Type Definitions** following the list of alarm conditions, for a description of alarm types.

<u>Alarm No.</u>	<u>Alarm Description</u>	<u>Test Register</u>	<u>Units</u>	<u>Scale Group</u>	<u>Alarm Type</u>
01	Over Current Phase A	1003	Amps	A	A
02	Over Current Phase B	1004	Amps	A	A
03	Over Current Phase C	1005	Amps	A	A
04	Over Current Neutral	1006	Amps	B	A
05	Over Current Ground	1007	Amps	C	A
06	Under Current Phase A	1003	Amps	A	B
07	Under Current Phase B	1004	Amps	A	B
08	Under Current Phase C	1005	Amps	A	B
09	Current Unbalance Phase A	1010	Tenths %		A
10	Current Unbalance Phase B	1011	Tenths %		A
11	Current Unbalance Phase C	1012	Tenths %		A
12	Phase Loss, Current	2122	Tenths %		C
13	Over Voltage Phase A	1018	Volts	D	A
14	Over Voltage Phase B	1019	Volts	D	A
15	Over Voltage Phase C	1020	Volts	D	A

<u>Alarm No.</u>	<u>Alarm Description</u>	<u>Test Register</u>	<u>Units</u>	<u>Scale Group</u>	<u>Alarm Type</u>
16	Over Voltage Phase A-B	1014	Volts	D	A
17	Over Voltage Phase B-C	1015	Volts	D	A
18	Over Voltage Phase C-A	1016	Volts	D	A
19	Under Voltage Phase A	1018	Volts	B	A
20	Under Voltage Phase B	1019	Volts	B	A
21	Under Voltage Phase C	1020	Volts	B	A
22	Under Voltage Phase A-B	1014	Volts	B	A
23	Under Voltage Phase B-C	1015	Volts	B	A
24	Under Voltage Phase C-A	1016	Volts	B	A
25	Voltage Unbalance A	1026	Tenths %		A
26	Voltage Unbalance B	1027	Tenths %		A
27	Voltage Unbalance C	1028	Tenths %		A
28	Voltage Unbalance A-B	1022	Tenths %		A
29	Voltage Unbalance B-C	1023	Tenths %		A
30	Voltage Unbalance C-A	1024	Tenths %		A
31	Voltage Loss (Loss of A,B, or C but not all)	2122	Volts	D	D
32	Over KVA 3-Phase Total	1050	KVA	E	A
33	Over KW Into the Load 3-Phase Total	1042	KW	E	A
34	Over KW Out of the Load 3-Phase Total	1042	KW	E	A
35	Over KVAR Into the Load 3-Phase Total	1046	KVAR	E	A
36	Over KVAR Out of the Load 3-Phase Total	1046	KVAR	E	A
37	Over Current Demand Phase A	1701	Amps	A	A
38	Over Current Demand Phase B	1702	Amps	A	A
39	Over Current Demand Phase C	1703	Amps	A	A
40	Over Current Demand 3 Phase Total	1700	Amps	A	A
41	Over Frequency	1001	Hertz	F	A
42	Under Frequency	1001	Hertz	F	B
43	Lagging True Power Factor	1034	Thousandths		E
44	Leading True Power Factor	1034	Thousandths		F
45	Lagging Displacement Power Factor	1038	Thousandths		E
46	Leading Displacement Power Factor	1038	Thousandths		F
47	Reserved				
48	Reserved				
49	Over Value THD Current Phase A	1051	Tenths %		A
50	Over Value THD Current Phase B	1052	Tenths %		A
51	Over Value THD Current Phase C	1053	Tenths %		A
52	Over Value THD Voltage Phase A	1055	Tenths %		A
53	Over Value THD Voltage Phase A	1056	Tenths %		A
54	Over Value THD Voltage Phase A	1057	Tenths %		A
55	Over Value THD Voltage Phase A-B	1058	Tenths %		A
56	Over Value THD Voltage Phase B-C	1059	Tenths %		A
57	Over Value THD Voltage Phase C-A	1060	Tenths %		A
58	Over K-Factor Phase A	1071	Tenths %		A
59	Over K-Factor Phase B	1072	Tenths %		A
60	Over K-Factor Phase C	1073	Tenths %		A
61	Over Predicted KVA Demand	1748	KVA	E	G
62	Over Predicted KW Demand	1746	KW	E	G
63	Over Predicted KVAR Demand	1747	KVAR	E	G
64	Over KVA Demand Level 1	1733	KVA	E	G
65	Over KVA Demand Level 2	1733	KVA	E	G
66	Over KVA Demand Level 3	1733	KVA	E	G
67	Over KW Demand Level 1	1731	KW	E	G

<u>Alarm No.</u>	<u>Alarm Description</u>	<u>Test Register</u>	<u>Units</u>	<u>Scale Group</u>	<u>Alarm Type</u>
68	Over KW Demand Level 1	1731	KW	E	G
69	Over KW Demand Level 1	1731	KW	E	G
70	Over KVAR Demand	1732	KVAR	E	G
71	Over Lagging 3 Phase Avg. Power Factor	1730	Thousandths		H
72	Under 3-Phase Total Real Power	1042	KW	E	I
73	Over Reverse 3-Phase Power	1042	KW	E	J
74	Phase Reversal	1117			K
75	Status Input 1 Transition from Off to On				L
76	Status Input 2 Transition from Off to On				L
77	Status Input 3 Transition from Off to On				L
78	Status Input 4 Transition from Off to On				L
79	Status Input 5 Transition from Off to On				L
80	Status Input 6 Transition from Off to On				L
81	Status Input 7 Transition from Off to On				L
82	Status Input 8 Transition from Off to On				L
83	Status Input 1 Transition from On to Off				M
84	Status Input 2 Transition from On to Off				M
85	Status Input 3 Transition from On to Off				M
86	Status Input 4 Transition from On to Off				M
87	Status Input 5 Transition from On to Off				M
88	Status Input 6 Transition from On to Off				M
89	Status Input 7 Transition from On to Off				M
90	Status Input 8 Transition from On to Off				M
91-98	Reserved				
99	End of Incremental Energy Interval				N
100	Power-Up/Reset				O
101	End of Demand Interval				N
102	End of Update Cycle				N
103	Over Analog Input Channel 1	1191	Integer Value		P
104	Over Analog Input Channel 1	1192	Integer Value		P
105	Over Analog Input Channel 1	1193	Integer Value		P
106	Over Analog Input Channel 1	1194	Integer Value		P
107	Under Analog Input Channel 1	1191	Integer Value		Q
108	Under Analog Input Channel 1	1192	Integer Value		Q
109	Under Analog Input Channel 1	1193	Integer Value		Q
110	Under Analog Input Channel 1	1194	Integer Value		Q
111-120	Reserved				
201	Voltage Surge A-N/A-B		Volts	D	R
202	Voltage Surge B-N		Volts	D	R
203	Voltage Surge C-N/C-B		Volts	D	R
204	Current Surge Phase A		Amps	A	R
205	Current Surge Phase B		Amps	A	R
206	Current Surge Phase C		Amps	A	R
207	Current Surge Neutral		Amps	B	R
208	Voltage Sag A-N/A-B		Volts	D	S
209	Voltage Sag B-N		Volts	D	S
210	Voltage Sag C-N/C-B		Volts	D	S
211	Current Sag Phase A		Amps	A	S
212	Current Sag Phase B		Amps	A	S
213	Current Sag Phase C		Amps	A	S
214	Current Sag Neutral		Amps	B	S

ALARM TYPE DEFINITIONS

<u>Alarm Type</u>	<u>Alarm Description</u>	<u>Alarm Operation</u>
A	Over Value Alarm	If the test register value exceeds the setpoint long enough to satisfy the pickup delay period, the alarm condition will be true. When the value in the test register falls below the dropout setpoint long enough to satisfy the dropout delay period, the alarm will dropout. Pickup and Dropout setpoints are positive, delays are in seconds.
B	Under Value Alarm	If the test register value is below the setpoint long enough to satisfy the pickup delay period, the alarm condition will be true. When the value in the test register rises above the dropout setpoint long enough to satisfy the dropout delay period, the alarm will dropout. Pickup and Dropout setpoints are positive, delays are in seconds.
C	Phase Loss, Current	The unbalance current alarm will occur when any phase current deviates from the average of the phase currents by the percentage pickup value and remains at or above the pickup value long enough to satisfy the specified pickup delay in seconds. When the unbalance between each phase and the average of all phase currents remains below the dropout value for the specified dropout delay period, the alarm will dropout. Pickup and Dropout setpoints are positive, delays are in seconds.
D	Phase Loss, Voltage	The Phase Loss Voltage alarm will occur when any one or two phase voltages (but not all) fall to the pickup value and remain at or below the pickup value long enough to satisfy the specified pickup delay. When all of the phases remain at or above the dropout value for the dropout delay period, or when all of the phases drop below the specified phase loss pickup value, the alarm will dropout. Pickup and Dropout setpoints are positive, delays are in seconds.
E	Lagging P.F.	The Lagging Power Factor alarm will occur when the test register value becomes more lagging than the pickup setpoint (i.e. closer to -0.010) and remains more lagging long enough to satisfy the pickup delay period. When the value becomes equal to or less lagging than the dropout setpoint (i.e. closer to 1.000) and remains less lagging for the dropout delay period, the alarm will dropout. Pickup and Dropout setpoints are negative, delays are in seconds.
F	Leading P.F.	The Leading Power Factor alarm will occur when the test register value becomes more leading than the pickup setpoint (i.e. closer to 0.010) and remains more leading long enough to satisfy the pickup delay period. When the value becomes equal to or less leading than the dropout setpoint (i.e. closer to 1.000) and remains less leading for the dropout delay period, the alarm will dropout. Pickup and Dropout setpoints are positive, delays are in seconds.
G	Over Power Demand	The over power demand alarms will occur when the test register's absolute value exceeds the pickup setpoint and remains above the pickup setpoint long enough to satisfy the pickup delay period. When the absolute value drops to below the dropout setpoint and remains below the setpoint long enough to satisfy the dropout delay period, the alarm will dropout. Pickup and Dropout setpoints are positive, delays are in seconds.

<u>Alarm Type</u>	<u>Alarm Description</u>	<u>Alarm Operation</u>
H	Over Lagging Average P.F.	The Over lagging 3 Phase Average P.F. will occur when the test register is less leading than the pickup setpoint and remains less leading for the pickup delay period. When the value becomes less lagging than the dropout setpoint and remains less lagging for the dropout delay, the alarm will dropout. If a leading P.F. is selected for the pickup setpoint (i.e. a positive P.F.) then the alarm will be active for any lagging P.F. or for any leading P.F. between the pickup setpoint and unity. Pickup and Dropout setpoints can be positive or negative, delays are in seconds
I	Under Power	The Under power alarm will occur when the test register's absolute value is below the pickup setpoint and remains below the pickup setpoint long enough to satisfy the pickup delay period. When the absolute value rises above the dropout setpoint and remains above the setpoint long enough to satisfy the dropout delay period, the alarm will dropout. Pickup and Dropout setpoints are positive, delays are in seconds.
J	Over Reverse Power	The over reverse power alarm will occur when the test register's absolute value exceeds the pickup setpoint and remains above the pickup setpoint long enough to satisfy the pickup delay period. When the absolute value drops to below the dropout setpoint and remains below the setpoint long enough to satisfy the dropout delay period, the alarm will dropout. This alarm will only hold true for Reverse Power conditions, i.e. any positive power value will not cause the alarm to occur. Pickup and Dropout setpoints are positive, delays are in seconds.
K	Phase Reversal	Once enabled the phase reversal alarm will occur whenever the phase voltage waveform rotation differs from the default phase rotation. It is assumed that an ABC phase rotation is normal. If a CBA normal phase rotation is normal, the user should reprogram the Circuit Monitor's phase rotation from ABC (default) to CBA phase rotation. The pickup and dropout setpoints and delays for phase reversal do not apply.
L	Status Input Transitions Off to On	The Status Input transitions alarms will occur whenever the status input changes from off to on. The alarm requires no pickup or dropout setpoints or delays. The Alarm will dropout when the status input changes back to off from on. The pickup and dropout setpoints and delays do not apply.
M	Status Input Transitions On to Off	The Status Input transitions alarms will occur whenever the status input changes from on to off. The alarm requires no pickup or dropout setpoints or delays. The alarm will dropout when the status input changes back to on from off. The pickup and dropout setpoints and delays do not apply.
N	End Of Interval/Update Cycle	The End of Interval alarms mark the end of an interval, or update cycle. The pickup and dropout setpoints and delays do not apply.
O	Power-Up/Reset	The Power-Up/Reset alarm marks any time the Circuit Monitor powers up or resets. The pickup and dropout setpoints and delays do not apply.
P	Over Analog	The Over Analog alarms will occur whenever the test register value is more positive than the pickup setpoint (or less negative) and remains greater than the pickup long enough to satisfy the pickup delay. When the value becomes less positive than the dropout setpoint (or more negative) and remains below the setpoint long enough to satisfy the dropout delay, the alarm will dropout. Pickup and Dropout setpoints can be positive or negative, delays are in seconds.

<u>Alarm Type</u>	<u>Alarm Description</u>	<u>Alarm Operation</u>
Q	Under Analog	The Under Analog alarms will occur whenever the test register value is less positive than the pickup setpoint (or more negative) and remains less than the pickup long enough to satisfy the pickup delay. When the becomes more positive than the dropout setpoint (or less negative) and remains above the setpoint long enough to satisfy the dropout delay, the alarm will dropout. Pickup and Dropout setpoints can be positive or negative, delays are in seconds.
R	Voltage/Current Swell	The Voltage and Current Swell alarms will occur whenever the continuous RMS calculation is above the pickup setpoint and remains above the pickup setpoint for the specified number of cycles. When the continuous RMS calculations fall below the dropout setpoint and remain below the setpoint for the specified number of cycles, the alarm will drop out. Pickup and Dropout setpoints are positive, delays are in cycles.
S	Voltage/Current Sag	The Voltage and Current Sag alarms will occur whenever the continuous RMS calculation is below the pickup setpoint and remains below the pickup setpoint for the specified number of cycles. When the continuous RMS calculations rise above the dropout setpoint and remain above the setpoint for the specified number of cycles, the alarm will drop out. Pickup and Dropout setpoints are positive, delays are in cycles.

APPENDIX J—USING THE OPTICAL COMMUNICATIONS INTERFACE

GENERAL

All Series 2000 Circuit Monitors are equipped with a front panel optical communications port. A portable computer, equipped with POWERLOGIC software, can communicate through the optical port using a POWERLOGIC Optical Communications Interface (Class 3090 Type OCI-2000). Any communications that can be done over the RS-485 communications link—including Circuit Monitor setup and firmware upgrades—can also be done through the optical communications port using the OCI-2000. This appendix tells how to use the OCI-2000.

The OCI-2000 mounts magnetically to the Circuit Monitor and provides a standard nine-pin RS-232 interface. The nine-pin connector at the end of the OCI-2000's 10 foot cable, plugs into the serial port on a personal computer. If the computer has a 25-pin serial port, but no 9-pin serial port, you'll need a 9-pin to 25-pin serial conversion cable (not supplied with the OCI-2000).

The OCI-2000 is powered by a standard 9 volt alkaline battery, or by a 9 volt/100mA dc converter that plugs into a standard 110V ac receptacle. The battery and dc converter are not supplied with the OCI-2000. Use a 9 volt/100mA dc converter with a 3.5 millimeter mono jack.

ATTACHING THE OCI-2000 TO THE CIRCUIT MONITOR

Position the OCI-2000 so that the optical sensors on the OCI-2000 line up with the optical port on the Circuit Monitor. To do this, place the OCI-2000 in the lower left-hand corner of the Circuit Monitor front panel, so that the bottom edge of the OCI-2000 butts up flat against the inside, bottom edge of the Circuit Monitor bezel. Figure J-1 shows the correct placement of the OCI-2000. The OCI-2000 is shown in grey.

USING THE OCI-2000

To use the OCI-2000, complete the following steps:

1. Connect the OCI-2000 cable to the serial port of your computer.
2. Supply the OCI-2000 with power (using either a 9 volt battery or a 9 volt dc converter).
3. Attach the OCI-2000 to the Circuit Monitor as described above.
4. Turn the OCI-2000 on.

The OCI-2000 has a two-position power switch: I=On and O=Off. Turn the switch to the ON (I) position.

After completing steps 1 to 4 above, you should be able to communicate to the Circuit Monitor using POWERLOGIC software. If you cannot communicate, see troubleshooting on the following page.

TROUBLESHOOTING

If you are unable to communicate, perform the following checks:

1. Check to see that the OCI-2000 cable is securely connected to the computer's serial port.
2. Check to see that the OCI-2000 power switch is in the On (I) position.
3. Check to see that the OCI-2000 is properly placed as shown in figure J-1.
4. If using a 9 volt DC adapter, check to see that the jack is plugged all the way into the OCI-2000.
5. If using a battery, replace it with a fresh 9 volt alkaline battery.

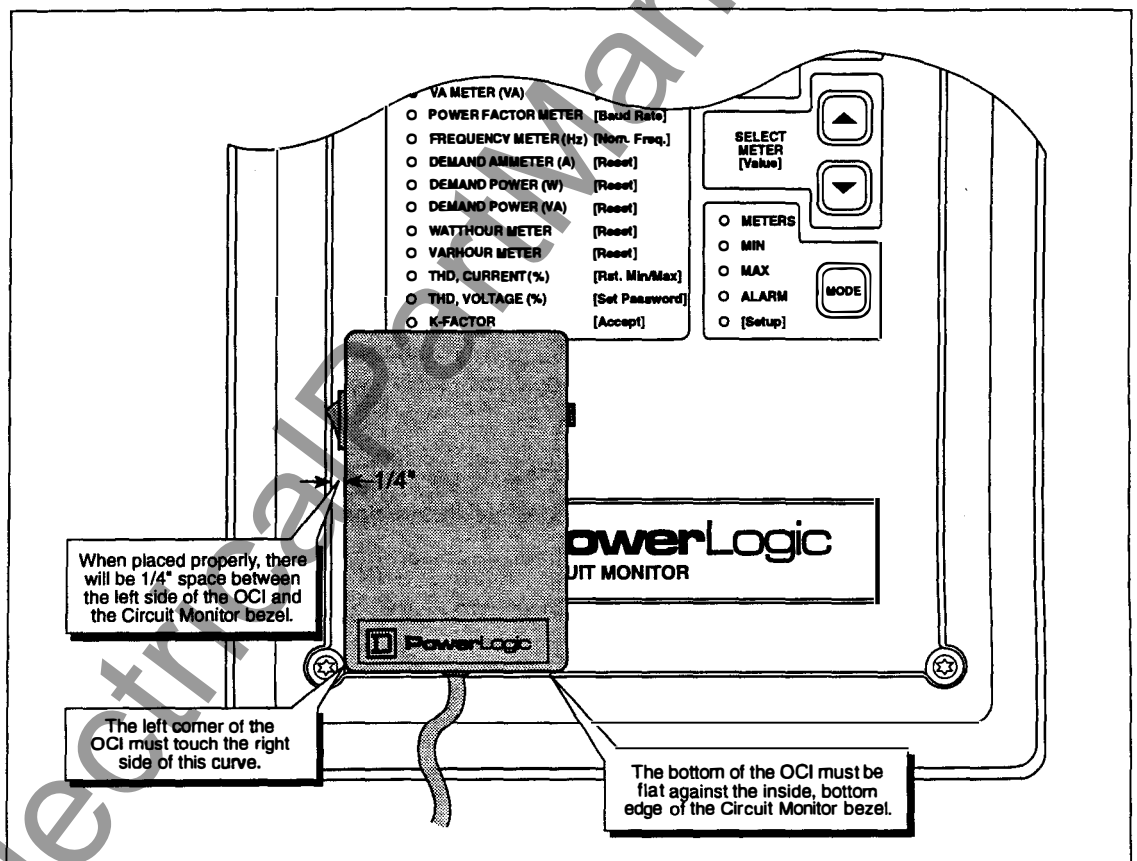

Figure J-1: Correct placement of the OCI-2000

APPENDIX K—READING AND WRITING REGISTERS FROM THE FRONT PANEL

The Circuit Monitor provides four setup modes: Configuration mode, Resets mode, Alarm/Relay mode, and Diagnostics mode. (See **The Setup Modes** in Chapter 4 for a description of these modes.) This appendix tells how to use the Diagnostics mode. Chapter 4 tells how to use the other three setup modes.

The Diagnostics mode lets you read and write Circuit Monitor registers, from the front panel. This capability is most useful to users who 1) need to setup an advanced feature which *cannot* be setup using the Circuit Monitor's normal front panel setup mode, and 2) do not have access to POWERLOGIC software to setup the feature.

For example, the default operating mode for a Circuit Monitor relay output is *normal*. To change a relay's operating mode from normal to some other mode (for example latched mode), you'd need to use either POWERLOGIC software or the Diagnostics setup mode.

NOTE

Use this feature with caution. Writing an incorrect value, or writing to the wrong register could cause the Circuit Monitor to operate incorrectly.

To read and/or write registers, complete the following steps:

1. Press the MODE button until the red LED next to [Setup] is lit.
The Circuit Monitor displays "ConFig."
2. Press the down arrow SELECT METER [Value] button until "diAg" is displayed.
3. Press the PHASE [Enter] button to select the Diagnostics mode.
The Circuit Monitor displays the password prompt "P - - - -."

4. Enter the master password.

To enter the password, use the SELECT METER [Value] buttons to increase or decrease the displayed value until it reaches the password value. Then press the PHASE [Enter] button.

The Circuit Monitor display alternates between "rEg No" (an abbreviation for register number) and "1000" (the lowest available register number).

5. Use the SELECT METER [Value] buttons to increase or decrease the displayed register number until it reaches the desired number.
6. Press the PHASE [Enter] button.

The Circuit Monitor reads the register, then alternately displays the register number (in the format r.xxxx) and the register contents (as a decimal value). If you are viewing a metered value, such as voltage, the Circuit Monitor updates the displayed value as the register contents change. (Note that scale factors are not taken into account automatically when viewing register contents.)

7. To read another register, press the MODE button, then repeat steps 5 and 6 above.

8. To write to a register, continue with step 9 below.

Note: Some Circuit Monitor registers are *read/write*, some are *read only*. You can write to read/write registers only.

9. Use the SELECT METER [Value] buttons to increase or decrease the displayed register number until it reaches the register you'd like to write.

10. Press the PHASE [Enter] button.

The Circuit Monitor alternately displays the register number and the register contents (as a decimal value).

11. Use the SELECT METER [Value] buttons to increase or decrease the displayed decimal value until it reaches the value you'd like to write.

If you've accidentally selected a *read only* register, the Circuit Monitor will not allow you to change the value.

12. Press the MODE button.

The Circuit Monitor displays "No".

13. To abort the register write, press the PHASE [Enter] button.

14. To write the value, press the up arrow SELECT METER [Value] button to change from "No" to "Yes." Then press the PHASE [Enter] button.

The display flashes, indicating that the value has been written, then returns to the register number.

15. To write another register, repeat steps 11-14 above.

16. To leave the Diagnostics mode, press the MODE button while the Circuit Monitor displays "rEg No."

NOTE

You can use the diagnostics mode to execute commands using the Circuit Monitor's command interface. First, write the desired values to the command parameter registers. Then, write the code to execute the command. See **Command Interface** in **Chapter 12** for a description of the command interface.

www.ElectricalPartManuals.com

www.ElectricalPartManuals.com

www.ElectricalPartManuals.com

*Form Mach
814-720-4641*

Square D Company
330 Weakley Rd
Smyrna, TN 37167 U.S.A.

Printed in U.S.A.

Order No. 3020IM9301R3/94
(Replaces 3020IM9301R10/93 dated April, 1993)



SQUARE D