

# Drive<sup>IT</sup> Low Voltage AC Drive

ACS800 Catalog  
Related tools and accessories



www.ElectricalPartManuals.com





www.ElectricalPartMaterials.com

Industrial

# Contents

## General

	pages
ABB	5
Industrial <sup>IT</sup> for drives	5
AC drives	5

## Products

ACS800 for AC motors, compact and complete	6 - 7
Direct Torque Control Technology	8
ACS800 Wall-mounted single drive	9 - 10
ACS800 Free standing single drive	9 - 10
ACS800 Single drive modules	11 - 12
ACS800 4-Quadrant drive	13 - 14
Standard application software	15
Start-up Assistant	16
Adaptive Programming	17

## Control Solutions

ABB's ready-made Control Solutions for specific drive applications	18
Centrifuge Control	19
Extruder Control	19
Pump and Fan Control	20
Spinning Control & Traverse Control	21
Crane Drive Control	22

## Others

ACS800 I/O	23
Control Panel	24
Fieldbus Control	25
Dynamic Braking	26 - 27
Programming Tool - DriveAP	28
Start-up and Maintenance Tool - DriveWindow 2	29
Start-up and Maintenance Tool - DriveWindow Light 2.1	30
Remote Monitoring Tool	31



www.ElectricalPartManuals.com

# Drive<sup>IT</sup> Low Voltage AC Drive ACS800



# Drive<sup>IT</sup> Low Voltage AC Drive

## ACS800

### ABB

ABB is one of the largest technology companies in the world with broad industry knowledge and geographic scope. It has approximately 135,000 employees in over 100 countries and occupies a leading position (1, 2 or 3) in each industry and product area it serves.

ABB offers complete industry and process specific solutions, from products to turnkey projects in utilities, oil, gas and petrochemicals, manufacturing and consumer industries, and process industries. ABB offers world-class collaborative business platforms and solutions based on Industrial<sup>IT</sup> open architecture software.

### Industrial<sup>IT</sup> for drives

As a key element of its business strategy, ABB has committed to a broad program of product development and positioning under the Industrial IT umbrella. This initiative is geared towards increasing standardization of ABB products as the “building blocks” of larger solutions, while building in functionality that will allow multiple products to interact seamlessly as components of real-time automation and information systems.

At the product level ABB's Industrial IT architecture ensures that ABB products can be integrated perfectly. Only products that satisfy a complete list of requirements stipulated by Industrial IT are certified to bear the Industrial IT enabled symbol, a special mark that indicates that the product can be easily integrated into the Industrial IT architecture, in a “plug & produce” manner.

Standardization and an architecture based on open standards increase engineering efficiency, speed of implementation and quality. The final result is higher productivity and more output from your plant. Through versatile connectivity the drives made by ABB can be easily integrated with different process automation systems fulfilling the requirements of Industrial IT.

Our Drive<sup>IT</sup> drive products provide the performance, energy savings and life extension that customers have come to expect from ABB.

### AC drives

AC drives are used to control the speed and torque of a standard induction motor, the workhorse of the industry. ABB is a market leader in both motors and drives worldwide.

AC drive technology extends the motor speed range from zero to high above the rated speed, increasing the productivity of the driven process. When a low capacity is enough, the drive reduces the machine speed and saves energy.

Accurate speed control of the manufacturing process optimizes the quality of the end product. The Direct Torque Control (DTC) developed by ABB has improved control accuracy by making speed encoders unnecessary.

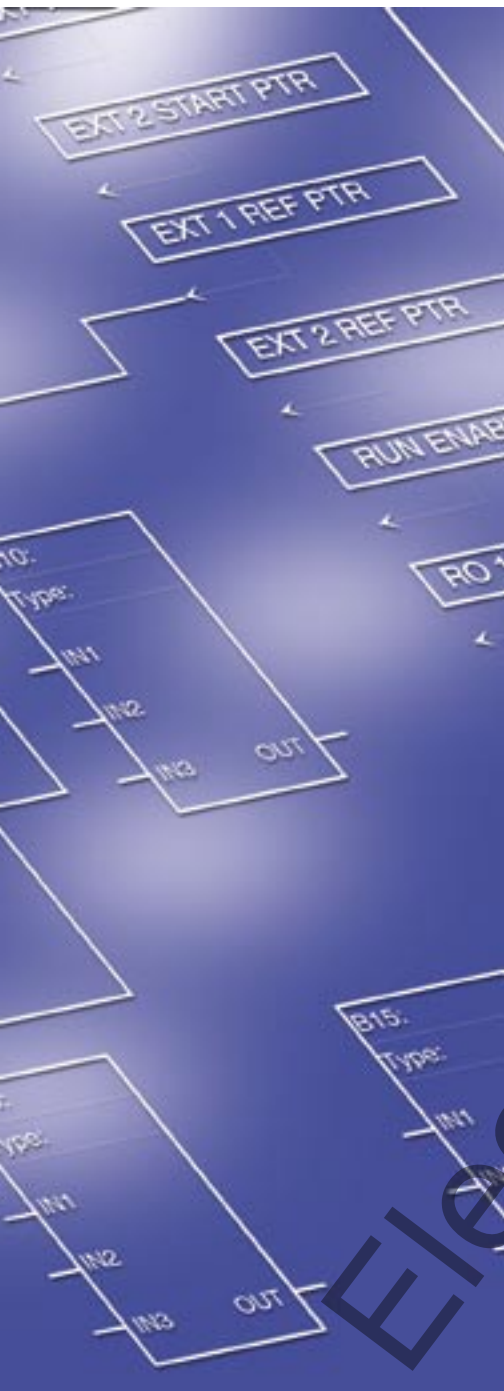

WWW .

# ACS800

for 0.75 to 3500Hp AC motors,  
compact and complete.



## Common technology for different applications

One of the main benefits of the ACS800 series is a wide range of drive products with common technologies. This includes Start-up Assistant, Adaptive Programming and DTC, common user and process interfaces, software tools for sizing, commissioning and maintenance and common spare parts.

## Premium Technology - DTC

The heart of the ACS800 is DTC - Direct Torque Control, its first class motor control system. The consistently excellent performance of the ACS800 guarantees that the drive is not the limiting factor in your process.

DTC technology is well proven in various applications and demanding environments guaranteeing the high reliability of the drive.

## Start-up Assistant

ABB AC drives have always been top of their class in user-friendliness. This product series brings a whole new meaning to “user-friendliness”. Thanks to the Start-up Assistant, the commissioning and tuning of a high performance drive could not be easier.

## Adaptive Programming

The ACS800 goes one step further compared to normal parameter programming with the addition of Adaptive Programming. It is like having a small PLC inside your drive. Adaptive Programming needs no additional hardware or software but is always there when needed.

## Integration and Compact Design

Anything that is required from an AC drive, like EMC and harmonic filters, is inside the drive, so no extra space or cabling is needed. Furthermore, there is always space inside the ACS800 for three option modules for I/O extensions, fieldbuses, pulse encoder interface or a PC connection.

ACS800 voltage power range

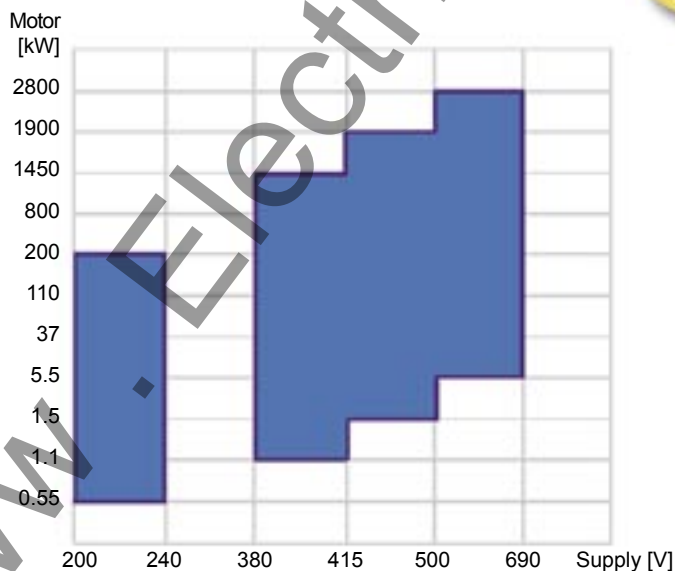

## Environmentally sound products

ABB is a signatory to the ICC (International Chamber of Commerce) Business Charter for Sustainable Development and is working towards fulfilling its requirements. ABB AC drives follow all 16 ICC principles and the basic function of variable speed drives is to minimize the environmental impact by matching the speed of the driven machine to the actual need in the process. This often means that the environmental load reduction in the process is ten times more than the environmental load caused by the manufacture, transport and disposal of the drives.

The manufacturing of AC drives complies with ISO 14001 standards.

## Technical specifications for the ACS800-U1/-U2/-U4/-17

### Mains connection

3-Phase supply voltage:	$U_{2IN} = 208...240\text{ V} \pm 10\%$ $U_{3IN} = 380...415\text{ V} \pm 10\%$ $U_{5IN} = 380...500\text{ V} \pm 10\%$ $U_{7IN} = 525...690\text{ V} \pm 10\%$
Frequency:	48...63 Hz
Power factor:	$\cos\varphi_1 = 0.98$ (fundamental) $\cos\varphi = 0.93...0.95$ (total)
Power factor (ACS800-17):	$\cos\varphi_1 = 1$ (fundamental) $\cos\varphi = 0.99$ (total)

### Efficiency

At nominal power:	
ACS800-Ux	98%
ACS800-17	97%

### Motor connection

3-Phase output voltage:	$0...U_{2IN}/U_{3IN}/U_{5IN}/U_{7IN}$
Frequency control:	$0... \pm 300$ Hz
Field weakening point:	8...300 Hz
Motor control software:	ABB's Direct Torque Control (DTC)
Torque control:	<u>Torque step rise time:</u>
Open loop	<5 ms with nominal torque
Closed loop	<5 ms with nominal torque
	<u>Non-linearity:</u>
Open loop	$\pm 4\%$ with nominal torque
Closed loop	$\pm 1\%$ with nominal torque
Speed control:	<u>Static accuracy:</u>
Open loop	10% of motor slip
Closed loop	0.01% of nominal speed
	<u>Dynamic accuracy:</u>
Open loop	0.3...0.4%sec. with 100% torque step
Closed loop	0.1...0.2%sec. with 100% torque step

### Environmental limits

Ambient temperature:	
Transportation:	-40...+70°C
Storage:	-40...+70°C
Operation:	-15...+50°C, no frost allowed 40...50°C at reduced output current (1%/1°C).
Operation (ACS800-17):	0...+50°C 40...50°C at reduced output current (1.5%/1°C).
Relative humidity:	5 to 95%, no condensation allowed.
Cooling method:	Dry clean air
Altitude:	0...1000 m without derating 1000...4000 m with derating (690 V units 1000...2000 m with derating)

# Direct Torque Control Technology

## DTC Technology - key in the ACS800 family

Direct Torque Control is an optimized motor control method for AC drives that allows direct control of all the core motor variables. This opens up AC drive capabilities never before realized and offers benefits for all applications.

## What is Direct Torque Control?

Direct Torque Control, DTC, is a revolutionary motor control method for AC drives which allows accurate control of both motor speed and torque without pulse encoder feedback from the motor shaft, down to zero speed. In DTC, stator flux and torque are used as primary control variables. The motor state calculations are updated by the high speed digital signal processor at 40,000 times a second in the advanced motor software model. Due to the continuous updating of the motor state and the comparison of the actual values to the reference values, every

single switching in the drive is determined separately. This feature will always produce the optimal switching combination and can instantly react to dynamic changes such as load shocks or power interruptions. In DTC, there is no need for a separate voltage and frequency controlled pulse width modulator.

## Unequalled motor speed & torque control

Open loop dynamic speed control accuracy matches that of AC drives using closed loop flux vector control. The ACS800 delivers static speed control accuracy of 0.1% to 0.5% of nominal speed - more than adequate for most industrial applications. In applications requiring even more precise speed regulation, an optional pulse encoder can be used. With an open loop torque step rise time of less than 5 milliseconds - compared to over 100 ms in AC drives using sensorless flux vector control - the ACS800 AC drive is unbeatable.

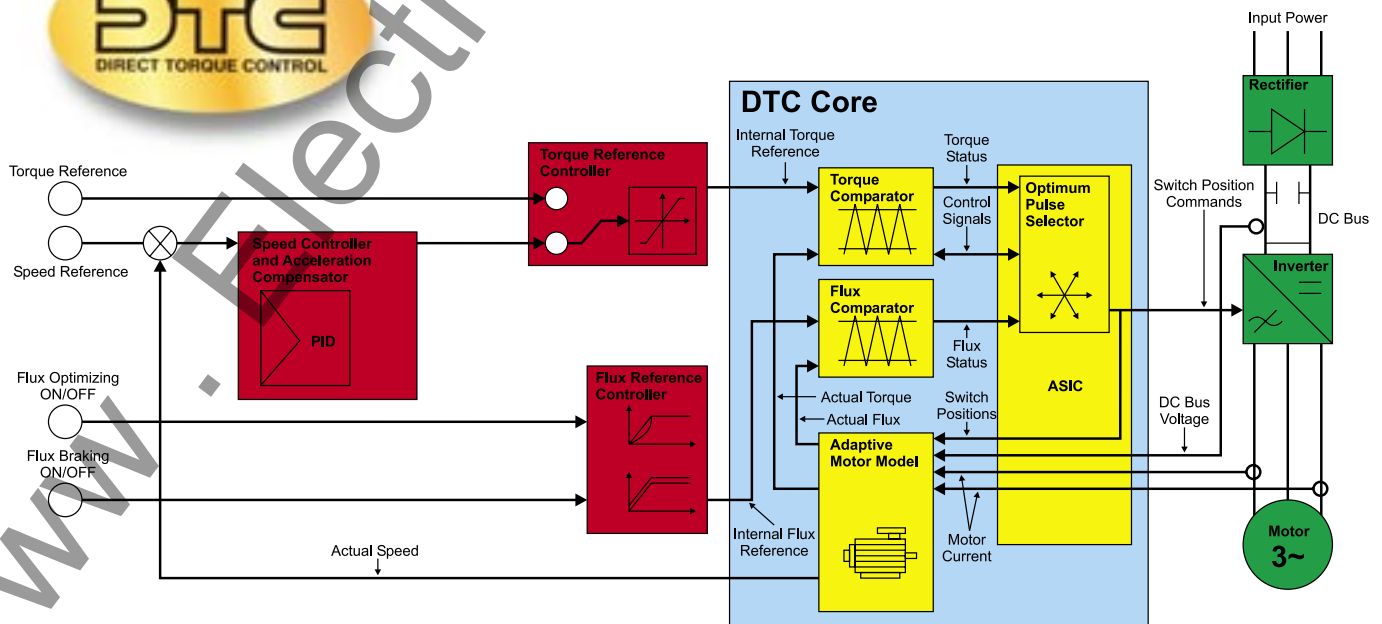
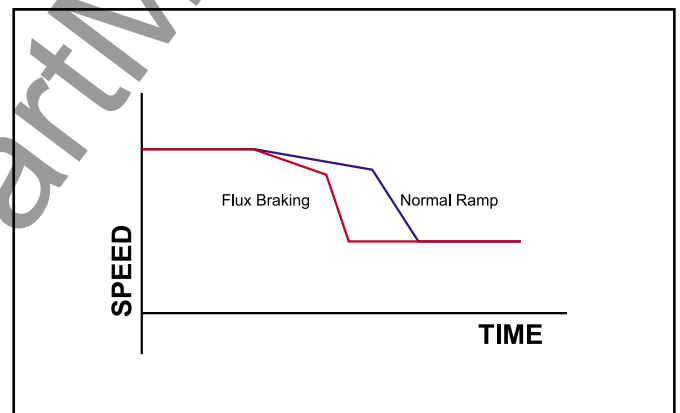
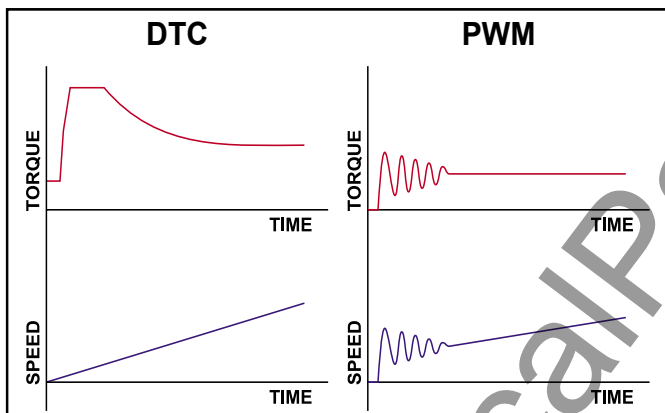

# ACS800 Wall-mounted single drive

ACS800-U1, up to 150 Hp

# ACS800 Free standing single drives

ACS800-U2 and ACS800-02, up to 600 Hp



## Compact Complete Single Drives

ACS 800-U1 offers wall mount capability through 150 HP in NEMA Type 1 and NEMA Type 12 enclosures. ACS800-02 is the floor standing single drive, shown at the right above, available in a NEMA Type 1 enclosure. It offers the slimmest profile available requiring less than 14 inches in width for a 600 HP requirement. ACS800-02 also offers a unique roll in/out feature while leaving customer power terminations untouched. We offer this same ACS800-02 free standing product with an extension enclosure providing a disconnect and fuses and it is called the ACS800-U2.

## Fits anywhere

The ACS800-02 may be mounted in a bookshelf configuration with the slim face forward. When using the bookshelf mount even side by side installations are possible. In addition the ACS800-02 offers the possibility of a flat mount leaving the user the possibility to optimize the depth or the width.

## Everything inside

From the smallest ACS800-U1 to the largest ACS800-02 and ACS800-U2 there is an extensive selection of built-in features and accessories. The standard features include a choke for harmonic filtering and drive protection, extensive and flexible I/O, user friendly control panel with a start up assistant feature and a quiet long lifetime fan.

If even more features are required, a wide selection of built-in options are available. The ACS800-U2 with its extension enclosure offers a disconnect and fuses with top entry and exit as standard, but it allows even more room for built in options.

### Main standard hardware features:

#### Common built-in features:

- NEMA 1 protection class
- Compact design
- Harmonic filtering choke inside
- Long lifetime cooling fan and capacitors
- Extensive, programmable I/O
- Inputs galvanically isolated
- Three I/O and fieldbus extension slots inside
- Alphanumeric, multilingual control panel with a Start-up Assistant feature
- Large power terminals allowing use of over sized or aluminium cable

#### Additionally in ACS800-U2:

- Free standing
- Fused disconnect
- Enclosure extension

### Accessories for the ACS800-U1, -02 and -U2:

- Brake chopper
- EMC filter / two alternatives:
  - EN 61800-3, 2<sup>nd</sup> environment, unrestricted distribution
  - EN 61800-3, 1<sup>st</sup> environment, restricted distribution
- Analog and digital I/O extension modules
- Fieldbus modules
- Pulse encoder interface module

### Accessories for the ACS800-U1:

- NEMA 12

### Accessories for the ACS800-02 and -U2:

- Common mode filters for motor protection - standard for 250 Hp and larger drives (R8 frame)

### Accessories requiring enclosure extension for the ACS800-U2:

- Contactor with emergency stop pushbutton
- 1 or 2 thermistor relays
- 3 Pt100 relays
- Cable top entry and exit
- Customer terminal block

In addition several external accessories available like du/dt filter, brake resistor.

## Enclosure

Degree of Protection:  
NEMA 1 (Standard)  
NEMA 12 (Optional) for ACS800-U1

H1 = Height with conduit box  
H2 = Height without conduit box  
W1 = Width of the standard unit  
W2 = Width with enclosure extension  
N/A = not available

- 1) This dimension applies to bookshelf mounting. For flat type mounting the width and depth change places.
- 2) With enclosure extension the depth is increased by 1" due to the fused disconnect handle.
- 3) Not available at the time of printing.
- 4) ACS800-U1 without conduit box does not fulfill NEMA 1 requirements.

Type	Nominal ratings					Module Type	Noise	Cooling Air Flow Requirements	
	Max. Current	Normal use		Heavy-duty use				Noise level dBA	Heat Dissipation Watts
	$I_{MAX}$ A	$I_{2N}$ A	$P_N$ Hp	$I_{2hd}$ A	$P_{hd}$ Hp				
Three phase supply voltage 200, 208 or 230 V. The power ratings are valid at nominal voltage (230 V)									
ACS800-U1-0001-2	6.5	4.9	1	3.5	.75	R2	62	100	21
ACS800-U1-0002-2	8.2	6.6	1.5	4.6	1	R2	62	100	21
ACS800-U1-0003-2	10.8	8.1	2	6.6	1.5	R2	62	100	21
ACS800-U1-0004-2	13.8	11	3	7.5	2	R2	62	120	21
ACS800-U1-0006-2	24	21	5	13	3	R3	62	160	41
ACS800-U1-0009-2	32	27	7.5	17	5	R3	62	200	41
ACS800-U1-0011-2	46	34	10	25	7.5	R3	62	250	41
ACS800-U1-0016-2	62	42	15	31	10	R4	62	340	61
ACS800-U1-0020-2	72	54	20	42	15	R4	62	440	61
ACS800-U1-0025-2	86	69	25	54	20	R5	65	530	99
ACS800-U1-0030-2	112	80	30	68	25	R5	65	610	99
ACS800-U1-0040-2	138	104	40	80	30	R5	65	810	99
ACS800-U1-0050-2	164	132	50	104	40	R6	65	1190	236
ACS800-U1-0060-2	202	157	60	130	50	R6	65	1190	236
ACS800-U1-0070-2	282	192	75	154	60	R6	65	1440	236

$I_{MAX}$ : Maximum current available for 10 seconds at start.  
 $I_{2N}$ : Continuous base current at 40°C (104°F) allowing 110% overload for 1 minute in every 5 minutes.  
 $I_{2hd}$ : Continuous base current at 40°C (104°F) allowing 150% overload for 1 minute in every 5 minutes.

$P_{hd}$ ,  $P_N$ : Typical motor power.  
 The current ratings are the same regardless of the supply voltages.  
 The rated current of the ACS 800 must be higher than or equal to the rated motor current to achieve the rated motor power given in the table.

Type	Nominal Ratings					Module Type	Noise	Cooling Air Flow Requirements	
	Max. Current	Normal use		Heavy-duty use				Noise level dBA	Heat Dissipation Watts
	$I_{max}$ A	$I_{2N}$ A	$P_N$ Hp	$I_{2hd}$ A	$P_{hd}$ Hp				
Three phase supply voltage 380, 400, 415, 440, 460, 480 or 500 V. The power ratings are valid at nominal voltage (500 V)									
ACS800-U1-0004-5	6.5	4.9	3.0	3.4	2.0	R2	62	120	21
ACS800-U1-0005-5	8.2	6.2	3.0	4.2	2.0	R2	62	140	21
ACS800-U1-0006-5	10.8	8.1	5.0	5.6	3.0	R2	62	160	21
ACS800-U1-0009-5	13.8	11	7.5	8.1	5.0	R2	62	200	21
ACS800-U1-0011-5	17.6	14	10	11	7.5	R2	62	250	21
ACS800-U1-0016-5	24	21	15	15	10	R3	62	340	41
ACS800-U1-0020-5	32	27	20	21	15	R3	62	440	41
ACS800-U1-0025-5	46	34	25	27	20	R3	62	530	41
ACS800-U1-0030-5	62	42	30	34	25	R4	62	610	61
ACS800-U1-0040-5	72	52	40	37	30	R4	62	810	61
ACS800-U1-0050-5	86	65	50	52	40	R5	65	990	99
ACS800-U1-0060-5	112	79	60	65	50	R5	65	1190	99
ACS800-U1-0070-5	138	96	75	77	60	R5	65	1440	99
ACS800-U1-0100-5	164	124	100	96	75	R6	65	1940	236
ACS800-U1-0120-5	202	157	125	124	100	R6	65	2310	236
ACS800-U1-0140-5	282	180	150	156	125	R6	65	2810	236
ACS800-U2-0170-5	326	192	150	162	125	R7	71	3150	360
ACS800-U2-0210-5	404	240	200	192	150	R7	71	3550	360
ACS800-U2-0260-5	432	284	200	224	150	R7	71	4600	360
ACS800-U2-0270-5	480	316	250	240	200	R8	72	4950	718
ACS800-U2-0300-5	568	361	300	302	250	R8	72	5350	718
ACS800-U2-0320-5	568	435	350	340	250	R8	72	5350	718
ACS800-U2-0400-5	720	510	400	370	300	R8	72	6650	718
ACS800-U2-0440-5	904	545	450	490	400	R8	72	6800	718
ACS800-U2-0490-5	1017	590	500	515	450	R8	72	7250	718
ACS800-U2-0550-5	1017	670	550	590	500	R8	72	8900	718
ACS800-U2-0610-5	1017	704	600	590	500	R8	72	10050	718

Frame	NEMA 1 Enclosure										NEMA 12 Enclosure									
	H1		H2		W1		W2		Depth		Weight		H1		W1		Depth		Weight	
	mm	in	mm	in	mm	in	mm	in	mm	in	kg	lbs	mm	in	mm	in	mm	in	kg	lbs
R2	405	15.94	370	14.57	165	6.496	N/A	N/A	226	8.898	9	19	528	20.79	263	10.35	242	9.528	16	35
R3	471	18.54	420	16.54	173	6.811	N/A	N/A	265	10.43	12	26	528	20.79	263	10.35	272	10.71	19	42
R4	606	23.86	490	19.29	240	9.449	N/A	N/A	271	10.67	20	44	780	30.71	320	12.6	280	11.02	28	62
R5	739	29.09	602	23.7	265	10.43	N/A	N/A	286	11.26	30	66	780	30.71	320	12.6	295	11.61	40	88
R6	900	35.43	700	27.56	300	11.81	N/A	N/A	360	14.17	60	132	3)	3)	3)	3)	3)	3)	3)	3)
R7	1503	59.17	N/A	N/A	250 <sup>1)</sup>	9.84	609	23.98	495 <sup>1)2)</sup>	19.49	100	220	3)	3)	3)	3)	3)	3)	3)	3)
R8	2130	83.86	N/A	N/A	350 <sup>1)</sup>	13.78	800	31.5	585 <sup>1)2)</sup>	23.03	230	506	3)	3)	3)	3)	3)	3)	3)	3)

# ACS800 Single drive modules

ACS800-U4, up to 600 Hp



## Optimized construction

The ACS800-U4 has several benefits that make it the optimal choice for panel builders.

No special EMC proof cabinets are needed. ACS800-U4 drives feature built-in EMC filtering, which restricts both radiated and conducted emissions within EN 61800-3 limits without the need for any extra hardware.

Innovative mounting hardware minimizes the number of bolts required to attach the drive module. Mounting of the control unit and control panel is easy thanks to the DIN rail mounting and new type of mounting platform.

Detailed cabinet assembly instructions are provided with every drive. The instructions include cabinet layout examples, the required air volumes and other necessary information.

The compact size, with plenty of integral options, minimizes both space requirements and the amount of assembly work needed.

## Easy cabling

The easily accessible power terminals provide plenty of space around them, making power cabling for the ACS800-U4 easy. Additionally, a separate control unit enables easy access to the I/O terminals. The control unit can be

optimally positioned inside the cabinet to enable access to the I/O terminals without needing to open the drive module.

The need for busbars and cables in the cabinet has been minimized by having the incoming power terminals on the top of the module. This enables use of the optimal cabling route.



### Main standard hardware features:

- Optimized design for cabinet assembly
- EMC compliant to 2nd environment, restricted distribution
- Modular design allowing wide variety of variants
- Easy access to power terminals
- Easy access to I/O terminals
- Compact design
- AC line reactor for harmonic filtering
- Long life time cooling fan and capacitors
- Extensive, programmable I/O
- Inputs galvanically isolated
- Three I/O and fieldbus extension option slots available
- Large power terminals allowing use of oversized or aluminium cable

### Accessories for the ACS800-U4

#### Built-in options:

- Brake chopper
- EMC filter:
  - EN 61800-3, 2<sup>nd</sup> environment, unrestricted distribution
- Common mode filters for motor protection - standard for 250 Hp and larger
- Analog and digital I/O extension modules
- Fieldbus modules
- Pulse encoder interface module

#### Other options:

- Remote control panel and mounting platform

Type	Nominal ratings					Module Type	Noise	Cooling Air Flow Requirements	
	Max. Current	Normal use		Heavy-duty use				Noise level dBA	Heat Dissipation Watts
	$I_{MAX}$ A	$I_{2N}$ A	$P_N$ Hp	$I_{2hd}$ A	$P_{hd}$ Hp				
Three phase supply voltage 380, 400, 415, 440, 460, 480 or 500 V. The power ratings are valid at nominal voltage (500 V)									
ACS800-U4-0170-5	326	192	150	162	125	R7	71	3050	324
ACS800-U4-0210-5	404	240	200	192	150	R7	71	3850	324
ACS800-U4-0260-5	432	284	200	224	200	R7	71	4550	324
ACS800-U4-0270-5	480	316	250	240	200	R8	72	6850	732
ACS800-U4-0300-5	568	361	300	302	250	R8	72	6850	732
ACS800-U4-0320-5	568	435	350	340	300	R8	72	6850	732
ACS800-U4-0400-5	720	510	400	370	350	R8	72	7850	732
ACS800-U4-0440-5	904	545	450	490	400	R8	72	7600	732
ACS800-U4-0490-5	1017	590	500	515	450	R8	72	8100	732
ACS800-U4-0550-5	1017	670	550	590	500	R8	72	9100	732
ACS800-U4-0610-5	1017	704	600	632	550	R8	72	9700	732

#### Nominal Ratings:

$I_{MAX}$ : maximum output current. Available for 10 s at start.

#### Typical Ratings: Normal duty use

$I_{2N}$ : continuous current allowing 110%  $I_N$  for 1min/ 5 min at 40°C.

$P_N$ : typical motor power in normal duty use.

#### Heavy-duty use

$I_{2hd}$ : continuous current allowing 150%  $I_{hd}$  for 1min/ 5 min at 40°C.

$P_{hd}$ : typical motor power in heavy-duty use.

The current ratings are the same regardless of the supply voltage within one voltage range.

The ratings apply at 40°C ambient temperature. At higher temperatures (up to 50°C) the derating is 1%/1°C.

### Enclosure

Degree of Protection:  
IP 00  
Paint color:  
NCS 1502-Y (RAL 90021/PMS 420C)

Type	Height mm/in	Width mm/in	Depth mm/in
(RDCU control unit *)	282/41	126/4.96	41/1.61

\*) provided as standard with every unit

### Bookshelf design

Type	Height mm/in	Width mm/in	Depth mm/in	Weight kg/lbs.
R7	1120/44	435/17.1	467/18.4	100/225
R8	1555/61.2	575/22.6	564/22.1	205/451

Width dimension without cable connection plate.

# ACS800 4-Quadrant drive

Air cooled regenerative drive.

ACS800-17, 75 to 1250 Hp



## Complete 4-Quadrant drive

The high performance ACS800-17 4-Quadrant drive allows full power flow in motoring and generating. Transition between modes is fast due to the ultrafast DTC control method. Stepping from Pn to -Pn or vice versa takes only a few milliseconds. No dead time in transition is required. The drive provides full output voltage and even more. Output voltage can be boosted, which means that 100% output voltage is available even when the input voltage is 90%.

## Friendly but robust power line

Power companies set limits for the permissible harmonic content of current and voltage in order to prevent damage to equipment in the same environment. The ACS800-17 removes low order harmonics with line converter DTC control and high order harmonics with an LCL filter. The result is very clean power for 6, 12, 18 and 24 pulse rectifier solutions. The ultrafast DTC can even compensate for fast variations in line voltage. There is no risk of component damage due to voltage drops as in thyristor-based rectifiers in AC and DC drives.

## Energy savings

Most of the adjustable speed drive costs are energy costs. Often the investment is only a small fraction of total costs. Compared with the other braking methods like mechanical and resistor braking, the energy savings can be significant. Braking resistors also take up installation space and the handling of waste heat can be a problem.

## Easy and flexible

The standard software contains the Adaptive Programming feature that enables the user to make small modifications to the software. Other software alternatives are also available for special applications. There are two features that facilitate commissioning: the line converter is a plug and play product, so no settings are needed. The motor inverter parameters can be easily adjusted from the control panel with the new interactive software, Start-up Assistant.

## Excellent supply side features

The unique DTC/LCL filter features:

- Unity fundamental power factor
- Extremely low current and voltage harmonics
- Very small commutating notches

## DTC type control has several advantages:

- Ultra-fast response to load changes
- No fixed switching frequency, which avoids the risk of resonating
- Switching only when needed, resulting in less switching losses

## Other features resulting from the DTC's high stability:

- Needs no tuning according to grid inductance
- Plug and play line inverter

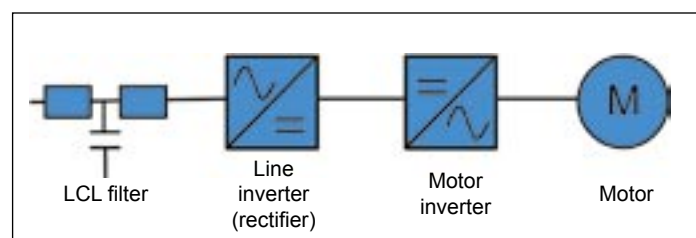

ACS800 main modules

## Excellent motor side features

The active line rectifier together with DTC ensures robust behavior even in demanding conditions.

- Torque is always stable even with unstable net voltage
- Excellent line voltage dip operation
- Extremely fast and smooth operation in motoring-regenerating-motoring transitions

The motor converter uses the standard ACS800 DTC motor control. This ultra-fast control loop enables fast responses to load and line voltage changes. The adjustable DC voltage boost function makes it possible to shift the field weakening point to higher frequencies. In many cases this feature enables a one size smaller motor to be selected.

In moderate voltage drops the control can maintain full DC voltage and the motors get full power. In heavy voltage drops power cannot be obtained from the line, but the drive can be kept ready to produce power immediately when voltage returns. The time between maximum motoring and regenerating power is in the range of milliseconds.

Type	Nominal Ratings				Module Type	Noise	Cooling Air Flow Requirements	
	Normal Duty use		Heavy Duty use				Noise level dBA	Heat Dissipation Watts
	$I_{2N}$ A	$P_N$ Hp	$I_{2hd}$ A	$P_{hd}$ Hp				
Three phase supply voltage 380, 400, 415, 440, 460, 480 or 500 V. The power ratings are valid at nominal voltage (500 V)								
ACS800-17-0100-5	112	100	84	60	R6i	65	3.4	1152
ACS800-17-0140-5	164	125	135	100	R7i	65	4.9	1152
ACS800-17-0215-5	246	200	185	150	R8i	65	7.2	2190
ACS800-17-0255-5	295	250	221	150	R8i	65	8.8	2190
ACS800-17-0325-5	368	300	276	200	R8i	65	11.1	2190
ACS800-17-0395-5	448	350	336	250	R9i	65	13.7	2190
ACS800-17-0495-5	565	450	424	350	R9i	65	17.4	2190
ACS800-17-0770-5	887	700	665	500	R11i	70	27.3	4368
ACS800-17-0935-5	1073	900	805	700	R11i	70	31.7	4368
ACS800-17-1090-5	1263	1000	947	800	R12i	73	38.9	6198
ACS800-17-1385-5	1593	1250	1195	1000	R12i	73	48.7	6198

## Enclosure

Degree of Protection:  
NEMA 1 (IP 21) Standard  
Paint color:  
Light beige RAL 7035 semi-gloss

Type	Height (in.)	Width (in.)	Depth (in.)	Weight (lbs.)	Noise (dBA)	Heatloss (kW)	Airflow (ft <sup>3</sup> /min)	Module Type	Cable Entry/Exit
ACS 800-17-0100-5	81.9	28.7	25.4	670	65	3.4	824	R6i	TOP/TOP
ACS 800-17-0140-5	81.9	28.7	25.4	670	65	4.9	824	R7i	TOP/TOP
ACS 800-17-0215-5	83.8	48.4	25.4	1980	65	7.2	2266	R8i	TOP/TOP
ACS 800-17-0255-5	83.8	48.4	25.4	1980	65	8.8	2266	R8i	TOP/TOP
ACS 800-17-0325-5	83.8	48.4	25.4	1980	65	11.1	2266	R8i	TOP/TOP
ACS 800-17-0395-5	83.8	48.4	25.4	2140	65	13.7	2266	R9i	TOP/TOP
ACS 800-17-0495-5	83.8	48.4	25.4	2140	65	17.4	2266	R9i	TOP/TOP
ACS 800-17-0770-5	83.8	158.7	25.4	3800	70	27.3	4562	R11i	TOP/TOP <sup>1)</sup>
ACS 800-17-0935-5	83.8	158.7	25.4	3800	70	31.7	4562	R11i	TOP/TOP <sup>1)</sup>
ACS 800-17-1090-5	83.8	204.7	25.4	6100	73	39.9	6386	R12i	TOP/TOP <sup>2)</sup>
ACS 800-17-1385-5	83.8	204.7	25.4	6100	73	48.7	6386	R12i	TOP/TOP <sup>2)</sup>

## Alternatives in reducing line harmonics

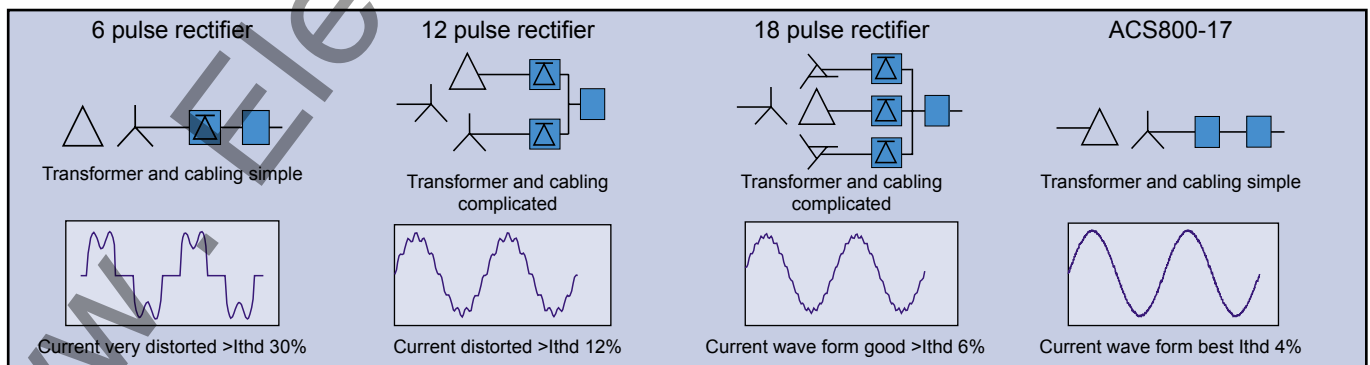

# Standard application software



Based on the Direct Torque Control technology, the ACS800 offers highly advanced features as standard. ACS800 standard application software provides solutions for virtually all AC drives applications.

## The standard application macros

The ACS800 features built-in, pre-programmed application macros for configuration of parameters such as inputs, outputs and signal processing.

- FACTORY SETTINGS for basic industrial applications
- HAND/AUTO CONTROL for local and remote operation
- PID CONTROL for closed loop processes
- SEQUENTIAL CONTROL for repetitive cycles
- TORQUE CONTROL for processes where torque control is required
- USER MACRO 1 & 2 for user's own parameter settings

## Software features

A complete set of standard software features offers premium functionality and flexibility.

- Accurate speed control
- Accurate torque control without speed feedback
- Adaptive Programming
- Automatic reset
- Automatic start
- Constant speeds
- Controlled torque at zero speed
- DC hold
- DC Magnetizing
- Diagnostics
- Flux braking
- Flux optimization
- IR compensation
- Master/follower control
- Mechanical brake control
- Motor identification
- Parameter lock
- Power loss ride-through
- Process PID control
- Programmable I/O
- Scalar control
- Speed controller tuning
- Start-up Assistant
- Trim function
- User-selectable acceleration and deceleration ramps

## Pre-programmed protection functions

A wide feature range provides protection for the drive, motor and the process.

- Ambient temperature
- DC overvoltage
- DC undervoltage
- Drive temperature
- Input phase loss
- Overcurrent
- Power limits
- Short circuit

## Programmable protection functions

- Adjustable power limits
- Control signal supervision
- Critical frequencies lock-out
- Current and torque limits
- Earth fault protection
- External fault
- Motor phase loss
- Motor stall protection
- Motor thermal protection
- Motor underload protection
- Panel loss

# Start-up Assistant

The easy way of commissioning.



L <- 0.0 rpm 0  
\*\* INFORMATION \*\*  
Press FUNC to start  
guided motor set up

Basic set up  
LANGUAGE ?  
[ENGLISH]  
Select(arrows)+ENTER

Motor set up  
MOTOR NOM CURRENT ?  
0 A  
Press FUNC for info

**READY TO START**

ABB AC drives have always been top of their class in user-friendliness. The new ACS800 AC drive brings a whole new meaning to “user-friendliness”. Thanks to the Start-up Assistant, the commissioning and tuning of a high performance drive could not be easier.

## Faster and easier commissioning

When you turn on your drive for the first time, the Start-up Assistant actively guides you through the commissioning procedure. You do not need to worry which parameters should be set, the Start-up Assistant does that.

To ensure a convenient commissioning procedure, the Start-up Assistant provides 14 different languages. It asks for motor nominal values as well as the I/O configuration and application specific parameters like acceleration and deceleration times. After this, the ACS800 is ready for your process.

All this saves you time, enabling you to concentrate on essential issues.

## On-line info system

To make it easier and more informative, there is an on-line info system available at each step, helping to set the correct values for each parameter. Just one push of the button and useful hints and information for that specific stage are available to you.

Each step also includes reference to the printed manuals if even more specific information is needed.

## Features

- Easy and fast commissioning procedure
- Intelligent guide to assist you through the commissioning
- Your own language
- On-line info system always available

The ACS800 offers you all this as a standard feature.

# Adaptive Programming

No extra hardware or software needed.



The freely programmable I/O and the extensive parameter selections make the ACS800 highly suitable for most applications. The ACS800, however, goes one step further with the addition of Adaptive Programming as a standard feature. It is like having a small PLC inside your drive. Adaptive Programming needs no additional hardware or software but is always there when needed.

## Programming done in a few minutes

Adaptive Programming consists of a set of blocks, which can be programmed to perform any of 20 predefined functions. All the common functions for making a real block program are available to you.

The user can freely define inputs to the blocks, wiring between the blocks and connections to the drive I/O or to the drive control. In this way the user is able to create new input and/or output signals and modify the drive's speed or torque control.

Programming the new ACS800 could not be any easier. All you need is the control panel and the programming is as simple as setting parameters. With Adaptive Programming the user is really able to modify the new ACS800 to suit the process perfectly.

Because no extra hardware or software is needed, the programming can be done in a few minutes even on-site.

## Optimal adaptability

- PLC like functions inside the drive
- Program your drive on-site during commissioning
- Create your own I/O signals, modify speed or torque reference chain or set a timer
- Do it without any additional hardware or software
- As simple as setting a parameter

There is also a Windows-based PC tool available for Adaptive Programming.

## Features

- 20 programmable function blocks
- Available functions:
  - Logical: AND, OR and XOR
  - Mathematical: add, mul, div, abs, max and min
  - Other: timer, switch, comparator, filter, SR, PI and user defined warnings or faults
- Freely definable execution order
- Easy documentation

The ACS800 offers you all this as a standard feature!

# Control Solutions

ABB's ready-made Control Solutions for specific drive applications.



## Centrifuge Control

Practical programmable sequences for conventional centrifuges. Decanter Control for accurate speed difference control of two shafts.

## Extruder Control

High starting torque, accurate speed/torque control and overload protection for demanding extruder applications.

## Pump and Fan Control

Pump and Fan Control provides better flow control and cost savings for up to 5 parallel motors in various industrial pump and fan applications.

## Spinning Control & Traverse Control

Spinning Control and Traverse Control make a perfect pair for precise control of spinning and traverse drives in textile machines.

## Crane Drive Control

The cost effective crane drive with optimal operational safety and outstanding performance already built in.

## Master/Follower Control

Reliable control via fiber optic link of several drives when motor shafts are coupled together.

## The main advantages of ABB's control solutions:

- Application-dedicated features
- Improved production
- No external PLC required
- User-friendly
- Easy to use
- Energy savings
- Smooth power loss ride-through
- Reduced costs
- Adaptive protective functions

# Control Solutions

## Centrifuge Control.



### Centrifuge Control features

- Centrifuge patterns
- Common DC-link configuration

### Additional Decanter Control features

- Direct communication between bowl and auger drive through optical fibers
- Automatic scaling of process speed based on the given gear box and belt ratio
- Speed difference control
- Load compensation of auger drive

### Centrifuge & Decanter Centrifuge as one

The Centrifuge application consists of programmable sequences for centrifuges e.g. in the food and beverage industries. The Decanter Control is integrated with the Centrifuge Control. This feature can be applied in all applications needing co-ordinated speed difference control.

A decanter (separator, centrifuge) is used to separate solid particles from fluid. In a typical decanter two rotating shafts called bowl and auger are used. Direct Torque Control enables smooth operation with different kinds of fluid viscosity and automatically adapts to load changes.

# Control Solutions

## Extruder Control.

### AC drives designed for extruder applications

An extruder is an application where material, typically in granulate or pulverized form, is driven through a screw to achieve a continuous material form to be further modified in the manufacturing process. Due to the material characteristics high starting torque is often needed. The screw and also the delicate mechanical parts of the machinery need to be protected against overload.

### Extruder application features

- High starting torque, excellent speed accuracy without encoder
- Adaptive torque limitation feature
- Two sets of parameter stall protection functions
- Digital potentiometer with two different accelerating and decelerating ramp times
- Four control locations



# Control Solutions

## Industrial Pump and Fan Control.



### Introduction

There are many pump and fan installations with quite extensive flow variations, such as water and sewage systems, paint spraying, mixture control, and metering. A common solution for these applications is to run several fixed speed pumps in parallel, with flow control accomplished by turning the pumps on and off. This kind of control causes discontinuous flow and adds a risk of damage caused by pressure transients.

Better flow control can be achieved with adjustable speed drives. The cost can be reduced by putting an adjustable speed drive on one pump and controlling the fixed speed pumps with the Pump and Fan Control application, PFC.

### Features

- The maximum number of units (pumps or fans) in parallel is 5 (1 with speed control and 4 with fixed speed)
- PI controller with
  - setpoint adjustment internal or external
  - actual value with five selectable units
- Setpoint steps for 4 motors
- Sleep and wake up level and delay settings
- Start and low frequency settings for 4 motors
- Start and stop delays
- Autochange delay and level settings
- Automatic interlocking between motors

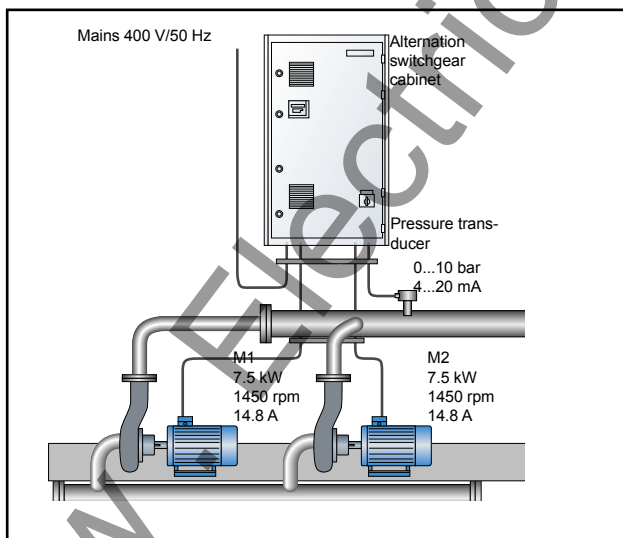

Pumping station for two pumps. ACS800 is installed inside the switchgear cabinet.

# Control Solutions

## Spinning Control & Traverse Control.



ACS800 Spinning Control is a solution for the precise control of spinning machine and for preventing yarn breakages. The ACS800 drive features allow maximum production and prevent yarn breakages during start-up and any power losses.

The Traverse Control is designed to run traverse drives guiding yarn into a yarn package for textile machines. To avoid layering at the reversal points of the yarn guide an instantaneous change, a P-jump, is made at speed.

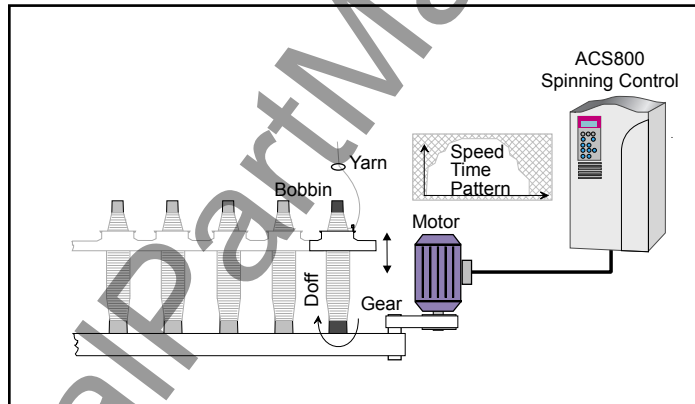

The principle of the Spinning Control.

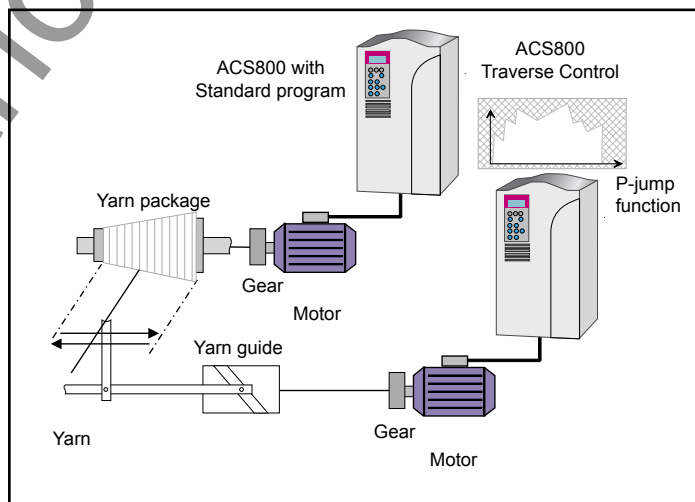

The principle of the Traverse Control.

### Features for Spinning Control:

- Wobulation function
- Shiftwise production calculation
- Automatic doff (pattern) selection
- 4 speed time patterns

### Features for Traverse Control:

- Wide selection for base speed reference
- Dynamic quick steps, real or proportional steps

# Control Solutions

## Crane Drive Control.



Standard ready-to-use crane drive solution with optimal operational safety and outstanding crane drive performance.

### Crane Drive Control

The cost-effective crane drive with safety and performance already built in.

- Easy installation and start-up reduces the total project costs
- Ready to use with proven modular crane functionality
- Accurate and fast torque response increases the operational productivity
- Smooth crane operation reduces maintenance and damage costs
- Available as single drive and multi drive with dynamic and regenerative braking

### Flexible user interface

- Joystick interface, with step or continuous speed reference
- Pendant control, with built in motor potentiometer
- Radio control, with step or continuous speed reference
- Fieldbus communication, for connection to PLC
- Limit switches, to ensure the crane works within a safe operation area

### Operational safety

- Mechanical brake functions for controlling and supervising the brake
- Adjustable fast stop procedure in case of overload or slack rope etc.
- Torque proving ensures that the motor has produced sufficient torque when opening the brakes
- Speed monitoring ensures that the speed stays within given limits. Also zero speed detection
- Torque monitoring supervises the correlation between the speed command and actual motor speed

### Outstanding performance

- Start and stop logic ensures that torque is available before the brake is released
- 4 different ramp times. Individual settings for acceleration and deceleration ramp times in both directions
- Torque memory presets torque when starting the hoist with suspended load, used for avoiding load drops when mechanical brake is released
- Power optimization ensures maximum hoist speed relative to the load. This optimizes the crane's capacity
- Optical master-follower link, used for load sharing between two mechanically connected motors. This can also be used for redundancy applications
- Electrical shaft function, for synchronizing two drives and motors without mechanical connection.
- Adjustable control for position correction



Analog and digital I/O channels are used for different functions such as control, monitoring and measurement purposes (e.g. motor temperature). In

addition, optional I/O extension modules are available providing additional analog or digital connections.

Below are the standard control connections of the ACS800 single drive with Factory Macro. For other ACS800 application macros, consult the appropriate firmware manual.

### Standard I/O on RMIO-01 Board

- **3 analog inputs:** differential, common mode voltage, galvanically isolated as a group.
  - One  $\pm 0(2) \dots 10$  V, 12 bit resolution
  - Two  $0(4) \dots 20$  mA, 12 bit resolution
- **2 analog outputs:**
  - $0(4) \dots 20$  mA, 10 bit resolution
- **7 digital inputs:** galvanically isolated as a group (can be split in two groups)
  - Input voltage 24 V
  - Filtering (HW) time 1 ms
- **3 relay (digital) outputs:**
  - Switchover contact
  - 24 V or 115/230 V AC
  - Max. 2 A
- **Reference voltage output:**
  - $\pm 10$  V  $\pm 0.5\%$ , max. 10 mA
- **Auxiliary power output:**
  - $+24$  V  $\pm 10\%$ , max. 250 mA

### Optional I/O

#### Analog I/O Extension Module RAIO-01

- **2 analog inputs:** galvanically isolated from 24 V supply and ground
  - $\pm 0(2) \dots 10$  V,  $0(4) \dots 20$  mA or  $\pm 0 \dots 2$  V, 12 bit resolution
- **2 analog outputs:** galvanically isolated from 24 V supply and ground
  - $0(4) \dots 20$  mA, 12 bit resolution

#### Digital I/O Extension Module RDIO-01

- **3 digital inputs:** individually galvanically isolated
  - Signal level 24 to 250 V or 115/230 V AC
- **2 relay (digital) outputs:**
  - Switchover contact
  - 24 V or 115/230 V AC
  - Max. 2 A

#### Pulse Encoder Interface Module RTAC-01

- **1 incremental encoder input:**
  - Channels A, B and Z (zero pulse)
  - Signal level and power supply for the encoder is 24 or 15 V
  - Single ended or differential inputs
  - Maximum input frequency 200 kHz

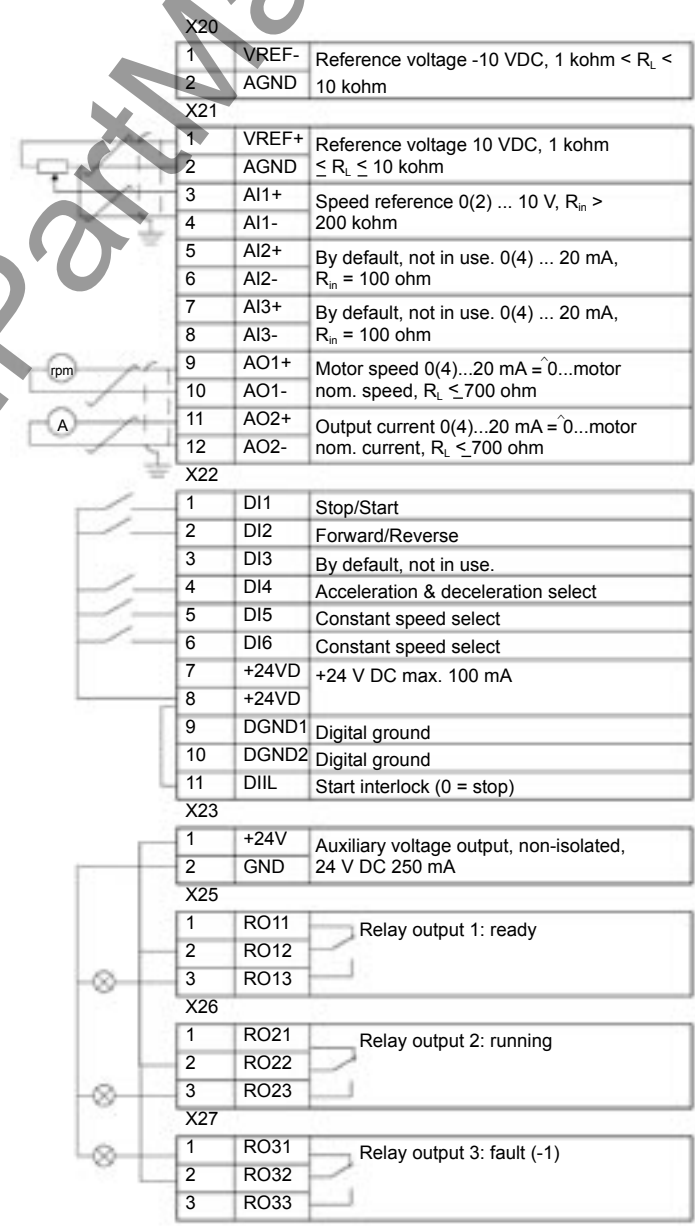

# Control Panel

ACS800 with user-friendly functionality.

The ACS800 control panel provides a great deal of information in plain, easy-to-understand language.

```
1 L -> 1242.0 RPM 1
SPEED 1242.0 RPM
CURRENT 76.00 A
TORQUE 86.00 %
```

## Actual value

The ACS800 control panel can display three separate actual values simultaneously.

Examples of these are:

- Motor speed
- Frequency
- Current
- Torque
- Power
- References
- DC bus voltage
- Output voltage
- Heatsink temperature
- Operating hours
- Kilowatt hours

## Control Panel

Multilingual alphanumeric display (4 lines x 20 characters) – plain text messages in 14 languages.

Intelligent removable control panel can be mounted on the ACS800 enclosure or remotely using a panel mounting option kit.

Local drive operation from control panel, including LOCAL/REMOTE selection, START/STOP, RESET, MOTOR ROTATION DIRECTION and REFERENCE setting.

## Fault memory

A built-in fault memory stores information relating to the latest 64 faults, each with a time stamp.

```
1 L -> 1242.0 RPM 1
2 LAST FAULT
OVERVOLTAGE
1121 H 1 MIN
```

## Parameter copying

Parameter copy feature allows all drive parameters to be copied from one frequency converter to another to simplify commissioning.

```
1 L -> 1242.0 RPM 1
UPLOAD <=<=<
DOWNLOAD =>=>=>
CONTRAST 4
```

## Centralized control

One panel can control up to 31 drives.

```
> > < >
1 21 40 100
>
III
```

## Simple arrangement

Parameters are organised into groups for easy programming.

```
1 L -> 1242.0 RPM 1
11 REFERENCE SELECT
3 EXT REF 1 SELECT
R11
```

## Start-up Assistant

Easy commissioning with the Start-up Assistant.

The Start-up Assistant actively guides you through the commissioning procedure.

```
MOTOR SETUP 4/10
MOTOR NOM CURRENT ?
(75.5 A)
ENTER: OK RESET: BACK
```

## Adaptive Programming

No extra hardware or software required for Adaptive Programming.

```
1 L -> 0.0 RPM 0
84 ADAPTIVE PROGRAM
05 BLOCK1
(MAX)
```



# Fieldbus Control

## Gateway to your process.



ABB AC drives have the connectivity to major automation systems. This is achieved with a dedicated gateway concept between the fieldbus systems and ABB drives.

The fieldbus gateway is a snap-on module that can be easily mounted inside the drive. As a result of the wide range of fieldbus gateways, your choice for an automation system becomes independent of your decision to use first-class ABB AC drives.

### Manufacturing Flexibility

#### Drive control

The drive Control Word (16 bit) provides a wide variety of functions from Start, Stop and Reset to Ramp Generator control. Typical setpoint values like Speed, Torque and Position can be transmitted to the drive with 15 bit accuracy.

#### Drive monitoring

A set of drive parameters and/or actual signals, like torque, speed, position, current etc., can be selected for cyclic data transfer providing fast data for operators and the manufacturing process.

#### Drive diagnostics

Accurate and reliable diagnostic information can be obtained via the drive Alarm, Limit and Fault Words reducing the down time of the drive and therefore also the down time of the manufacturing process.

#### Drive parameter handling

Total integration of the drives in the production process is achieved by single parameter read/write up to complete parameter set-up or download.

#### Easy to expand

Serial communication simplifies the latest trend of modular machine design enabling expansion of the installation at a later stage with low effort.

### Reduced Installation and Engineering Effort

#### Cabling

Substituting the large amount of conventional Drive Control cabling with a single twisted pair reduces costs and increases system reliability.

#### Design

The use of Fieldbus Control reduces engineering time at installation due to the modular structure of the hardware and software.

#### Commissioning and assembly

The modular machine configuration allows pre-commissioning of single machine sections and provides easy and fast assembly of the complete installation.

### Currently Available Gateways

- PROFIBUS-DP
- DeviceNet
- CANopen
- ControlNet
- ModbusPlus
- LONWORKS®
- Modbus
- Ethernet
- InterBus-S

# Dynamic Braking

## Brake Choppers and Resistors.

### Brake Chopper

The ACS800 series has built-in brake choppers for all types. Therefore, no additional space or installation time is needed. The brake chopper is part of the R2 and R3 frames. For all other frames a brake chopper is a selectable option.

Braking control is integrated into the ACS800 series. It controls the braking, supervises the system status and detects failures such as brake resistor and resistor cable short circuits, chopper short circuit, and calculated resistor overtemperature.

### Brake Resistor

The brake resistors are separately available for all ACS800 types. Resistors other than the standard resistors may be used providing the specified resistance value is not decreased, and the heat dissipation capacity of the resistor is sufficient for the drive application.

For ACS800 units, no separate fuses in the brake circuit are required if the following conditions are met:

- The ACS800 input power cable is protected with fuses
- No input power cable/fuse overrating takes place

Frame Size	Drive Part Number	Peak Braking HP	Duty Cycle=3sec regen, 27sec off						Duty Cycle=10sec regen, 50sec off					
			Part Number ABB 48431 <sup>(3)</sup>	Rohm	kwatt	Max Size			Part Number ABB 48431 <sup>(3)</sup>	Rohm	kwatt	Max Size		
						H	W	D				H	W	D
ACS800-U1-														
R2	0004-5	2 <sup>(1,4)</sup>	-020	44	.32	5	12	5	-020	44	.32	5	12	5
	0005-5	2.9 <sup>(1,4)</sup>	-020	44	.32	5	12	5	-020	44	.32	5	12	5
	0006-5	4 <sup>(1,4)</sup>	-020	44	.32	5	12	5	-021	44	.8	5	12	7
	0009-5	5.4 <sup>(1,4)</sup>	-021	44	.8	5	12	7	-021	44	.8	5	12	7
	0011-5	7.4 <sup>(1,4)</sup>	-021	44	.8	5	12	7	-022	44	1.2	5	12	10
R3	0016-5	10 <sup>(1,4)</sup>	-002	22	.82	6	12	11	-004	22	1.4	6	13	16
	0020-5	14.7 <sup>(1,4)</sup>	-003	22	1.14	6	13	13	-006	22	2.2	6	13	20
	0025-5	20 <sup>(1,4)</sup>	-004	22	1.4	6	13	16	-007	22	2.43	6	16	20
R4	0030-5	35 <sup>(1,4)</sup>	-031	13	1.87	6	13	20	-033	13	3.33	6	16	27
	0040-5	44 <sup>(1,4)</sup>	-032	13	2.2	6	19	20	-035	13	4.21	6	16	27
R5	0050-5	60 <sup>(1,4)</sup>	-096	8.5	2.75	6	27	13	-068	11	4.4	13	29	18
	0060-5	75 <sup>(1,4)</sup>	-097	8.5	5.3	13	29	18	-097	8.5	5.3	13	29	18
	0070-5	90 <sup>(1,4)</sup>	-120	8	6.27	13	29	18	-099	8.5	7.65	10	28	22
R6	0100-5	110 <sup>(1,4)</sup>	-159	5.3	4.77	13	29	18	-184	4.3	10.75	22	29	18
	0120-5	150 <sup>(1,4)</sup>	-183	4.3	6.2	13	29	18	-185	4.3	17.7	22	29	18
	0140-5	180 <sup>(1,4)</sup>	-184	4.3	10.7	22	29	18	-185	4.3	17.7	22	29	18
ACS800-U2-														
R7	0170-5	188	-271	2.9	14.2	22	29	18	-272	2.9	16.3	22	29	18
	0210-5	225	-271	2.9	14.2	22	29	18	-273	2.9	23.5	4	29	18
	0260-5	225	-271	2.9	14.2	22	29	18	-273	2.9	23.5	40	29	18
R8	0320-5	330	-331	2.2	17.8	31	29	18	-332	2.2	26.6	40	29	18
	0400-5	450	-393	1.7	24.5	40	30	18	-395	1.7	46.3	67	29	18
	0440-5	600	-480	1.2	32.7	49	30	23	-482	1.2	60.8	76	29	18
	0490-5	675	-514	1	34.2	49	30	23	-517	1	67.6	85	29	18
	0550-5	750	-514	1	34.2	49	30	23	-517	1	67.6	85	29	18
	0610-5	900	-515	1	40	58	30	18	-518	1	90	77	30	28

- 1 Resistors are mounted in a screened enclosure with separate termination compartment, removable cover, conduit knockouts, with NC thermal switch sensing unsafe temperature.
- 2 Quantity (2) resistor banks, field wired in series. The dimensions shown are for each resistor bank, the price shown is for both resistor banks.
- 3 Order acknowledgements may contain an R or P in the part number, indicating vendor information.
- 4 These values represent peak and continuous braking power of the braking chopper.

Frame Size	Drive Part Number	Peak Braking HP	Duty Cycle=30sec regen, 180sec off						Duty Cycle=60sec regen, 180sec off					
			Part Number	Rohm	kwatt	Max Size			Part Number	Rohm	kwatt	Max Size		
						H	W	D				H	W	D
ACS800-U1-														
R2	0004-5	2 <sup>(1,4)</sup>	-020	44	.32	5	12	5	-021	44	.8	5	12	7
	0005-5	2.9 <sup>(1,4)</sup>	-021	44	.8	5	12	7	-021	44	.8	5	12	7
	0006-5	4 <sup>(1,4)</sup>	-021	44	.8	5	12	7	-022	44	1.2	5	12	10
	0009-5	5.4 <sup>(1,4)</sup>	-022	44	1.2	5	12	10	-023	44	3	5	26.5	10
	0011-5	7.4 <sup>(1,4)</sup>	-023	44	3	5	26.5	10	-023	44	3	5	26.5	10
R3	0016-5	10 <sup>(1,4)</sup>	-006	22	2.2	6	13	20	-009	22	5.63	6	22	28
	0020-5	14.7 <sup>(1,4)</sup>	-008	22	3.17	6	13	28	-009	22	5.63	6	22	28
	0025-5	20 <sup>(1,4)</sup>	-008	22	3.17	6	13	28	-009	22	5.63	6	22	28
R4	0030-5	35 <sup>(1,4)</sup>	-035	13	4.2	6	16	27	-037	13	8.13	6	22	28
	0040-5	44 <sup>(1,4)</sup>	-036	13	6.3	6	22	28	-038	13	11.7	22	29	18
R5	0050-5	60 <sup>(1,4)</sup>	-069	11	6.88	6	19	28	-100	8.5	12.3	22	29	18
	0060-5	75 <sup>(1,4)</sup>	-100	8.5	12.27	22	29	18	-101	8.5	16.5	31	29	18
	0070-5	90 <sup>(1,4)</sup>	-100	8.5	12.27	22	29	18	-101	8.5	16.5	31	29	18
R6	0100-5	110 <sup>(1,4)</sup>	-162	5.3	13.2	22	29	18	-211	4	22.5	31	29	18
	0120-5	150 <sup>(1,4)</sup>	-185	4.3	17.1	22	29	18	-187	4.3	27.5	40	29	18
	0140-5	180 <sup>(1,4)</sup>	-211	4	22.5	31	29	18	-188	4.3	34.8	58	29	18
ACS800-U2-														
R7	0170-5	188	-273	2.9	23.5	40	29	18	-275	2.9	41.8	58	29	18
	0210-5	225	-274	2.9	29	49	29	18	-276	2.9	52.8	76	29	18
	0260-5	225	-274	2.9	29	49	29	18	-276	2.9	52.8	76	29	18
R8	0320-5	330	-334	2.2	40.1	58	29	18	(Qty 2)-514 <sup>(2)</sup>	(2)1	(2)34.2	49	30	23
	0400-5	450	-396	1.7	58.1	76	29	18	(Qty 2)-544 <sup>(2)</sup>	(2)9	(2)45.6	67	30	18
	0440-5	600	-484	1.2	81.1	58	29	18	(Qty 2)-573 <sup>(2)</sup>	(2)6	(2)73.5	76	30	18
	0490-5	675	-518	1	90	77	29	18	C/F					
	0550-5	750	-518	1	90	77	29	18	C/F					
	0610-5	750	-518	1	90	77	29	18	C/F					

- 1 Resistors are mounted in a screened enclosure with separate termination compartment, removable cover, conduit knockouts, with NC thermal switch sensing unsafe temperature.
- 2 Quantity (2) resistor banks, field wired in series. The dimensions shown are for each resistor bank, the price shown is for both resistor banks.
- 3 Order acknowledgements may contain an R or P in the part number, indicating vendor information.
- 4 These values represent peak and continuous braking power of the braking chopper.

# Programming Tool

## DriveAP for Adaptive Programming.

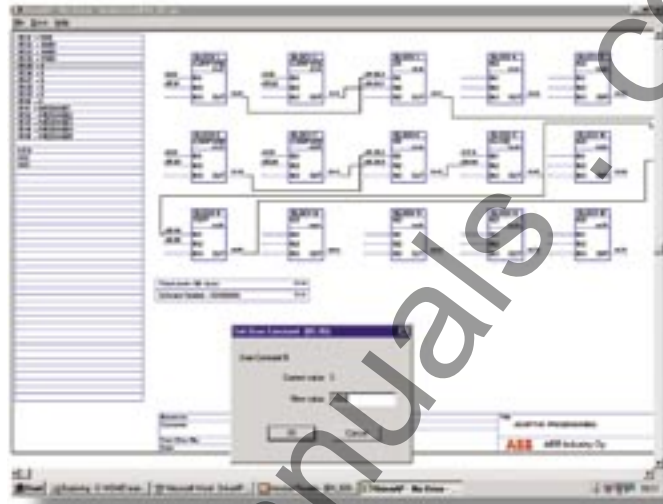

### Easy to use PC tool

DriveAP is a PC tool to create, document, edit and download Adaptive Programs. Adaptive Programming can be done with the standard control panel or with DriveAP. DriveAP offers a clear and easy way to develop, test and document Adaptive Programs with a PC.

DriveAP is a user-friendly tool to modify function blocks and their connections. No special programming skills are required. Basic knowledge about block programming is enough.

Adaptive Programming results are easy to document as hard copies or store as PC files with DriveAP.

### Upload or download

Adaptive Programs can be uploaded from connected drives and displayed graphically on a PC screen e.g. for service or documentation purposes.

Ready made Adaptive Programs can be downloaded to any of the connected drives.

### Three operating modes

- Stand Alone Mode - DriveAP is not connected to a drive. Adaptive Programming can be carried out in the office and downloaded later on
- Off-Line Mode - DriveAP is connected to a drive. Adaptive Programming is carried out in batch mode
- On-Line Mode - DriveAP is connected to a drive. Changes to the program are written immediately to the drive and actual values are shown on the screen in real time

DriveAP is part of the Drive<sup>IT</sup> folder of the Industrial<sup>IT</sup>.

### Features

- Easy to use tool, no special skills required
- Create and download new programs
- Document your programs
- Upload existing programs from the drive
- Operating modes
  - Stand Alone
  - Off-Line
  - On-Line

# Start-up and Maintenance Tool

## DriveWindow 2

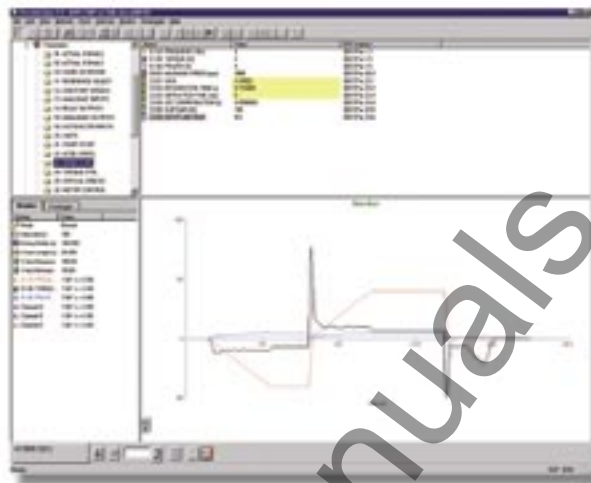

### Windows™ -based, user-friendly

ABB's DriveWindow is an advanced, easy-to-use tool for the commissioning and maintenance of drive systems in different industries. Its host of features and clear, graphical presentation of the operation make it a valuable addition to your system providing information necessary for troubleshooting, maintenance and service, as well as training.

DriveWindow is a 32 bit software that runs in the newer Microsoft® Windows environments. DriveWindow has connection kits for both laptop and desktop PCs.

With DriveWindow the user is able to follow the operation of two or more drives simultaneously by collecting the actual values from the drives onto a single screen or printout.

Additionally, the client part of DriveWindow may reside on one Local Area Network PC, and the server side on another PC closer to the drives. This enables plant-wide monitoring to be easily accomplished with two PCs.

### Powerful and versatile

- DriveWindow can access all drives connected to the high speed fiber optic network
- Signal values can be viewed as graphs from the drive/drives
- A screenful of signals and parameters from the drive can be monitored and edited at one time (off-line or on-line)
- View data collected and stored in the drive
- Fault diagnosis; DriveWindow indicates the status of drives, and also reads fault history data from the drive
- Remote monitoring, plant wide monitoring with two PCs
- Back-up of drive parameters; in fault situations the file can be easily reloaded, resulting in time savings
- Back-up parameters or software from the drive into PC files. This version allows the entire control board content to be saved and restored later - even to empty control boards. One empty spare control card can function as a spare part for many different sizes of drives

DriveWindow is part of the Drive<sup>IT</sup> folder of the Industrial<sup>IT</sup>.

### Features

- Easy-to-use tool for commissioning and maintenance
- Several drives connected and monitored at the same time
- Monitor, edit or save signals and parameters, clear graphical presentation
- High speed communication between PC and drive
- Versatile back-up functions

# Start-up and Maintenance Tool

## DriveWindow Light 2.1

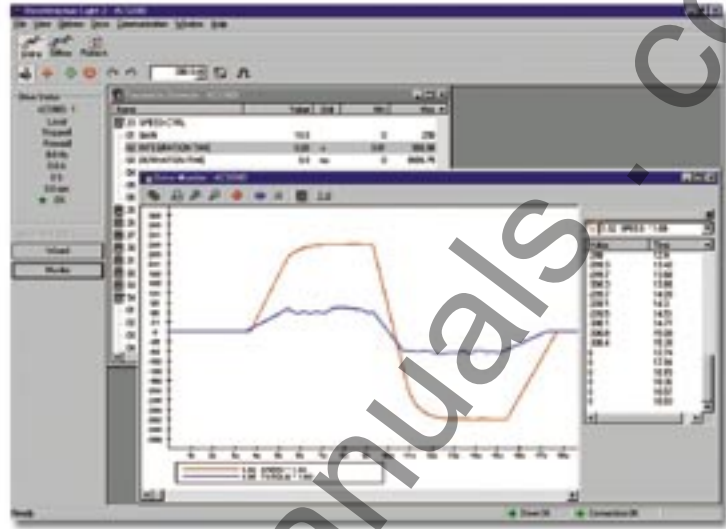

### Simple to use

DriveWindow Light 2.1 is a comprehensive commissioning and maintenance tool for ABB drives. This easy-to-use software is for editing, uploading and downloading drive parameters and, for example, monitoring the actual values and status information of the drive system.

DriveWindow Light 2.1 enables most drive parameters to be set offline in the office when uploaded from the drive, and then saved in the drive-specific files. The files can be further modified and downloaded to the respective drives at the installation site.

The configuration can then be tested and fine-tuned using the software's monitoring feature. The final parameter settings can be saved for back-up purposes and also printed out easily for customer documentation.

The DriveWindow Light 2.1 package consists of the software tool, based on 32-bit architecture of Microsoft® Windows environment, and the RS-232/RS-485 PC connection unit kit hardware. DriveWindow Light can also be used for the ACS140 and ACS400 with an RS-485/232 adapter (purchased separately).

DriveWindow Light is part of the Drive<sup>IT</sup> folder of the Industrial<sup>IT</sup>.

### Practical functions

- Parameter browser for editing (online/offline) and viewing parameter values online
- Parameter compare function for parameters in a drive and a parameter file
- Parameter back-up and restore
- Easy adjustment of pointer type parameters, e.g. Adaptive Programming
- Graphical and numerical monitoring of signals

# Remote Monitoring Tool

The intelligent Ethernet module NETA-01.



## Browser-based, user-friendly

The intelligent Ethernet module gives simple access to the drive via the Internet communicating via a standard web browser. The user can set up a virtual monitoring room wherever there is a PC with an Internet connection or via a simple dial-up modem connection. This enables remote monitoring, configuration, diagnostics and, when needed, control. The drive can also provide process related information, such as load level, run time, energy consumption and I/O data, the bearing temperature of the driven machine, for instance.

## No PC needed at local end

The intelligent Ethernet module has an embedded server with the necessary software for the user interface, communication and data storage. This gives ease of access, real time information and the possibility for two-way communication with the drive, enabling immediate response and actions, saving time and money. This is possible without using a PC at the local end, as required by other remote solutions.

## E-mail alerts

The module can also send condition triggered event alerts to predefined email addresses. This opens new possibilities for the monitoring and maintenance of unmanned applications across a range of industries, for instance water, wind power, building services and oil & gas, as well as any decentralised application where the user needs access to the drives from more than one location. It also provides an opportunity for OEMs and system integrators to support their installed base globally.

## Powerful and versatile

Up to nine drives can be connected to the intelligent Ethernet module via fiber optic links. It is available as an option for new drives, as well as an upgrade for existing systems. Ethernet allows the integration of office and process environments into a global network. The module supports the usual HTTP, IP, TCP, SMTP, BOOTP, UDP, Telnet and FTP protocols, as well as Modbus/TCP based process control. Access to the module is secured by user ID and passwords. Multiple security level enables the allocation of different access rights to normal users and administrators. Even higher levels of security can be achieved using a Virtual Private Network (VPN) connection.

The module is mounted onto a standard mounting rail inside or outside the drive unit, depending on drive type and configuration. It connects to the drive with fiber optic cables. The size of the module is 3.66" (h) x 1.38" (w) x 3.01" (d).

The IP address of the Ethernet module can be allocated freely. The user interface with the drive is created using embedded Java applets. The web page of the module is opened like any other web address. The home page shows a general overview of the system with traffic lights and action buttons to guide the user through the different sections.

## Features

- Virtual monitoring room for
  - Monitoring
  - Configuration of parameters
  - Diagnostics
  - Control, if needed
- Browser based access via
  - Intra-/extra-/Internet or
  - Simple dial-up modem connection
- E-mail alerts to predefined addresses
- No PC needed at the local end
- Can be used as a Modbus/TCP bridge for control purposes

# The ABB Product Family

## Small AC Drives

The Comp-AC family includes the ACS 140, and ACS 400, covering sizes from ¼ hp to 50 hp and voltages from 200 to 480 V.



## Large AC Drives

The ACS 800 Single and Multi-Drive family includes drives from 0.75 hp to 3,500 hp and voltages from 230 to 690 V.



## Medium-Voltage Drives

ABB's highly reliable ACS 1000 is available from 400 hp to 6,700 hp and voltages of 2.3, 3.3, and 4.16 kV.



## DC Drives and Motors

DCS 500 and DCS 400 DC Drives are available from 5 hp to 10,000 hp and voltages from 230 to 1,000 V. A wide range of DC motors are also available.



## Motors

Low-voltage AC motors from ABB range from ¼ hp to 800 hp and voltages from 208 to 480 V. Medium-voltage AC motors are also available.



# ABB

ABB Inc.  
Drives and Motors  
16250 W. Glendale Drive  
New Berlin, WI 53151  
Telephone (800) 752-0696  
Fax (262) 785-0397  
Internet <http://www.abb-drives.com>

ABB Oy  
Drives  
P. O. Box 184  
FIN - 00381 Helsinki  
Finland  
Telephone +358 10 22 11  
Telefax +358 10 222 2681  
Internet <http://www.abb.com/motors&drives>

ACS800-US-01 Rev. B  
Effective: 8/15/03  
Supersedes: Rev. A