

Substation Automation and Protection Division

Industrial Ground Current Fault Indicator - Ungrounded or High Resistance Grounded Distribution

Introduction - Remote Ground Fault Indicator

The Remote Ground Fault Indicator (RGFI) is a sensor and indicating device that provides a visual signal when a ground fault is present on a particular electric power circuit. The RGFI signals when a ground fault is located anywhere downstream of the monitored circuit. Many units are utilized on a distribution network. They are placed at points along the feeders, at branch circuit connections, and at loads.

The RGFI senses the presence of a 60-Hz residual current and a 600-Hz pilot signal. It consists of a current transformer, indicator unit, and a connecting two-wire cable. The device is self-powered; the current transformer is both a sensor and a power transformer for the indicator unit.

The indicator shows the fault path, traced by the residual and pilot currents, by illuminating two Light Emitting Diodes (LED's) on the face of the housing. All the detectors along the circuit path between the pilot signal generator and the fault location will illuminate during a fault. Those detectors with darkened LED's denote healthy circuits. The electrician can quickly trace the path of lighted detectors to the fault. The user installs the RGFI on the three-phase feeders and the drop-cables to loads. The preferred installation locations are at circuit junctions, where the electrician must be able to determine on which branch circuit the fault is located. The detectors are also placed at points along a single circuit to resolve the section that contains the fault. Figure 1 shows a typical cement strategy for placing RGFI's.

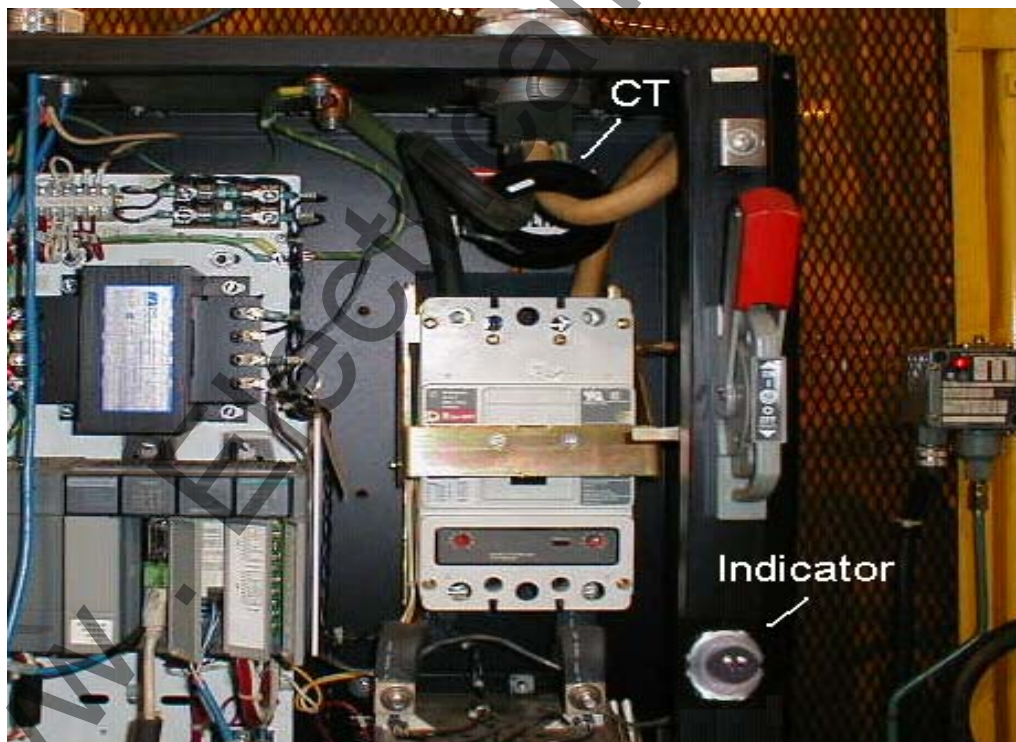

Figure 1 – Fault Indicator installed on a Welding Control Unit.



Figure 2 – Fault Indicator (RGFI)

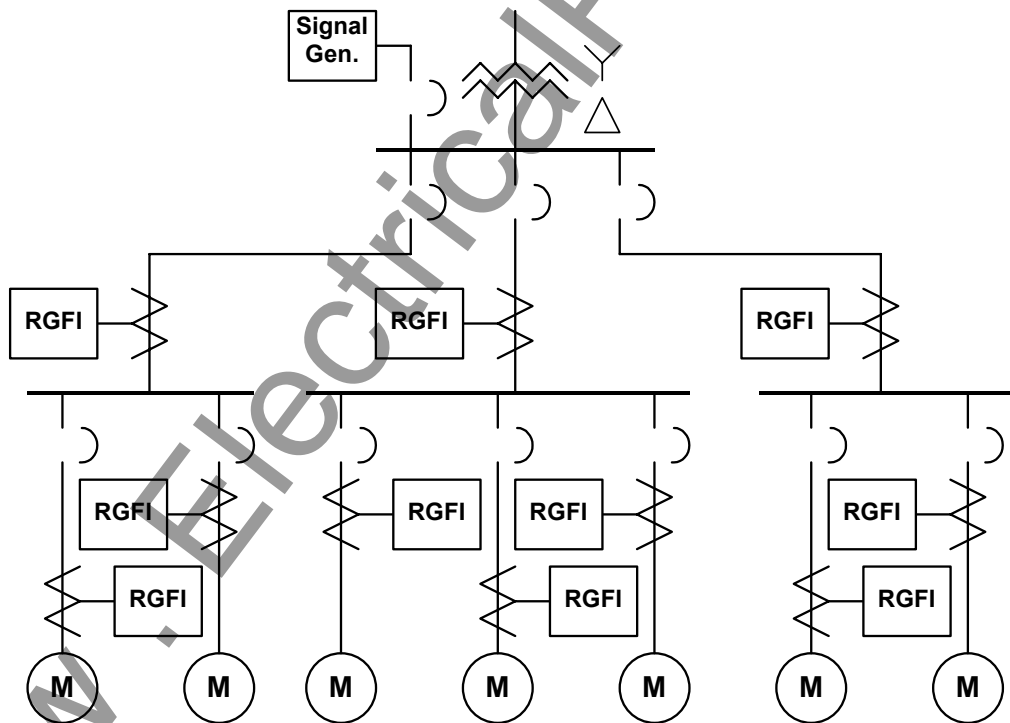

Figure 3 - Typical Application of the Remote Ground Fault Indicator.

Operation

The RGFI senses and powers a set of indicator LED's from the flow of the system's capacitance charging current or the pilot signal current during a ground fault. A unique current transformer with very low losses detects these currents. The transformer is configured as a current sensor that is sensitive to small residual currents (3-A to 10-A) of a two-, three-, or four-wire circuit. When there are residual feeder currents, a current signal flows from the current transformer to an indicator circuit. This circuit consists of two LED's placed on the housing face of the indicator, and protecting resistors and surge arrestors. The LED's are connected in anti-parallel to provide a light signal for an ac current. Each diode conducts on one-half of the cycle. High brightness diodes with a 30-degree viewing angle permit the indicator to be seen beyond 40-ft. The illuminating light gives indication of the presents of a network fault.

Electrical Circuit of the Remote Ground Fault Indicator.

The electrical environment in which the RGFI is place can experience significant large current flows during some types of fault conditions. The upper range of these currents is in the range of 200-kA, several orders of magnitude to the signal currents. The RGFI is designed to withstand the stress that comes from these current levels. The transformer is the first level of protection. It limits the energy delivered to the secondary circuit by operating in a saturation mode. Using wound tape construction for the core and using high-performance steels, the transformer has a very square saturation curve. For large primary currents the burden of the secondary circuit increases and quickly drives the current transformer into a deep saturation. When operating in the saturation region, the transformer can only deliver a limited amount of energy to the secondary circuit.

The effect of a current transformer operating in saturation mode is that the effective turns-ratio decreases. However, a consequence of saturation is that the voltage peaks on the transformer secondary. A series of resistors and metal oxide varistors (MOV's) snub the voltage to an appropriate level for the LED's. The total resistance is sized so that during normal operation, the voltage burden of the secondary circuit is below the saturation level of the current transformer. The resistance is divided into three components to form voltage dividers with the MOV's. During operation in the saturation mode, the voltage dividers deliver a voltage and current to the LED's that is greater than the design values but within the operating tolerances of the LED's.

Together, the saturating current transformer and the snubbing circuit provide protection for the LED's during large current flows in the primary circuit. Unlike electronic regulators, the saturating transformer core does not reach a breakdown threshold that will permit damaging energy to pass on through to the LED's.

The electrical environment for the RGFI is defined in Table 1. This includes the normal signal levels for illuminating the LED's, and the typical ranges of the large fault currents that may flow in the primary circuit. Other environmental parameters are listed which represent the industrial application.

Table 1 - Environmental Parameters for the Remote Ground Fault Indicator.

Parameter	Symbol	Min	Typical	Max
Input 60-Hz Voltage	V_{prim}		120 – 600-V	1000-V
Input 60-Hz Current (Note 1)	I_{prim}		10-kA – 67-kA	200-kA
Input 600-Hz Current	I_{signal}	3-A	7-A	15-A
Transient Voltages	V_{BIL}			45-kV
Operating Temperature	T_A	-40 C		+125 C

NOTES: 0.5s duration, one every 4 hours.

Application Notes

1. Normal application is at the load apparatus equipment.
2. All connections are three phases or line-line. Do not include ground or neutral conductors.
3. Applications at branch circuits may require grounding resistor adjustments.
4. Not for use on grounded distribution.

Contributed by:
Edward Hassick
Revision 0, 01/24/03

ABB Inc.
7036 Snowdrift Road
Allentown, PA 18106
800-634-6005 Fax 610-395-1055
Email: powerful.ideas@us.abb.com
Web: www.abb.com/substationautomation