

# TABLE OF CONTENTS

INTRODUCTION .....	3
DESCRIPTION .....	3
Latched Contactors .....	5
Anti-single-phase Mechanism .....	6
Nomenclature Description .....	6
Contacts .....	7
Operating Magnets .....	7
Disconnect Assembly .....	7
Arc Chutes .....	8
Power and Control Disconnects .....	9
Fuse Clips .....	9
INSTALLATION .....	9
MAINTENANCE .....	12
Inspections .....	12
Contacts .....	13
When to Replace Contacts .....	13
Contact Alignment .....	14
Measuring Contact Forces .....	14
Replacing Contacts (200- and 400-ampere only) .....	14
Replacing Contact Springs .....	15
Arc Chute Assembly .....	15
AC Magnet Assembly .....	18
DC Magnet Assembly .....	20
Replacing Magnet Coils .....	20
Replacing Side Frames .....	21
Replacing Main Shaft Assembly .....	21
Replacing Blowout Coil Base .....	22
Replacing Fuse Base .....	22
Power Stab Fingers .....	23
HARDWARE .....	23
TIGHTENING TORQUES .....	23
ELECTRICAL INTERLOCKS – IC2814E250, E251, E550, E551 and E451 Models .....	24
Adjustments .....	24
Interlock Ratings .....	25
Maintenance .....	25
Replacing and Rearranging Movable and Stationary Contacts .....	25
When to Replace or Service Electrical Interlocks .....	26
Replacing Complete Electrical Interlock Assembly .....	26
Models IC2814E411 thru E451 .....	26
Introduction .....	26
Description .....	27
Installation .....	27
Maintenance .....	27
IC2814 Latched Contactors .....	28
Adjustments .....	28
Anti-single-phase Mechanism .....	29
IC2814B211 CONTACTORS .....	31
Adjustments .....	31
When to Replace Contacts .....	32
RENEWAL PARTS .....	32

*These instructions do not purport to cover all details or variations in equipment nor to provide for every possible contingency to be met in connection with installation, operation or maintenance. Should further information be desired or should particular problems arise which are not covered sufficiently for the purchaser's purposes, the matter should be referred to the General Electric Company.*

[www.ElectricalPartManuals.com](http://www.ElectricalPartManuals.com)

# HIGH-VOLTAGE CONTACTORS

Before any adjustments, servicing, parts replacement or any other act is performed requiring physical contact with the electrical working components or wiring of this equipment, the POWER SUPPLY MUST BE DISCONNECTED.

## INTRODUCTION

These instructions cover high voltage, ac airbreak contactors. The contactors are designed for equipment used in starting ac motors with a line voltage from 600 volts to a maximum of 5,000 volts. Available contactors are listed in Table 1.

TABLE 1 AVAILABLE MODELS

CATALOG NUMBER	TYPE OF MAGNET	VOLTAGE	TYPE OF FUSE	POWER DISCONNECT STAB ON CHUTE ASSEMBLY	AUXILIARY ELECTRICAL INTERLOCKS
<b>400-AMPERE CONTACTORS</b>					
IC2814E210	AC	5000	No fuse	No	No
E211	DC	5000	No fuse	No	No
E220	AC	4800	Clip	Yes	No
E221	DC	4800	Clip	Yes	No
E230	AC	2400	Clip	Yes	No
E231	DC	2400	Clip	Yes	No
E240	AC	5000 <sup>1</sup>	Shorting Bar	Yes	No
E241	DC	5000	Shorting Bar	Yes	No
E250	AC	"	Clip <sup>1</sup>	Yes <sup>1</sup>	Yes
E251	DC	"	Clip <sup>1</sup>	Yes <sup>1</sup>	Yes
E270	AC	7200	Clip	Yes	No
E271	DC	7200	Clip	Yes	No
E620	AC	4800	Bolted	Yes	No
E621	DC	4800	Bolted	Yes	No
E630	AC	2400	Bolted	Yes	No
E631	DC	2400	Bolted	Yes	No
E670	AC	7200	Bolted	Yes	No
E671	DC	7200	Bolted	Yes	No
<b>200-AMPERE CONTACTORS</b>					
IC2814E510	AC	5000	No fuse	No	No
E511	DC	5000	No fuse	No	No
E520	AC	4800	Clip	Yes	No
E521	DC	4800	Clip	Yes	No
E530	AC	2400	Clip	Yes	No
E531	DC	2400	Clip	Yes	No
E540	AC	5000	Shorting Bar	Yes	No
E541	DC	5000	Shorting Bar	Yes	No
E550	AC	"	Clip <sup>1</sup>	Yes <sup>1</sup>	Yes
E551	DC	"	Clip <sup>1</sup>	Yes <sup>1</sup>	Yes
E570	AC	7200	Clip	Yes	No
E571	DC	7200	Clip	Yes	No
E720	AC	4800	Bolted	Yes	No
E721	DC	4800	Bolted	Yes	No
E730	AC	2400	Bolted	Yes	No
E731	DC	2400	Bolted	Yes	No
E770	AC	7200	Bolted	Yes	No
E771	DC	7200	Bolted	Yes	No
<b>700-AMPERE CONTACTOR</b>					
IC2814E411	DC	5000	No fuse	No	No
E421	DC	4800	Bolted	Yes	No
E431	DC	2400	Bolted	Yes	No
E441	DC	5000	Shorting Bar	Yes	No
E451	DC	"	Bolted <sup>1</sup>	Yes <sup>1</sup>	Yes

<sup>1</sup> Forms available for either 2400 or 4800 volts.

<sup>2</sup> Standard forms have fuses and disconnect stab.

<sup>3</sup> Special forms available without fuses and bolted connection.

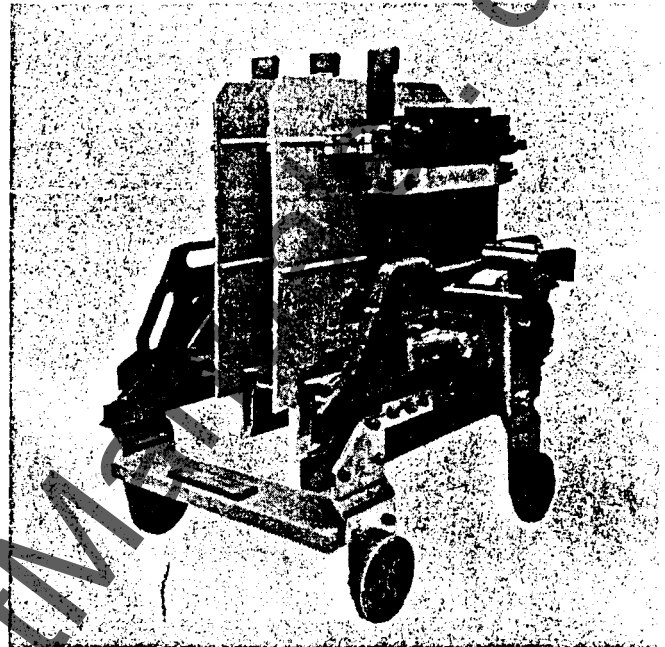

Fig. 1A. IC2814E220 one-high contactor less power fuses

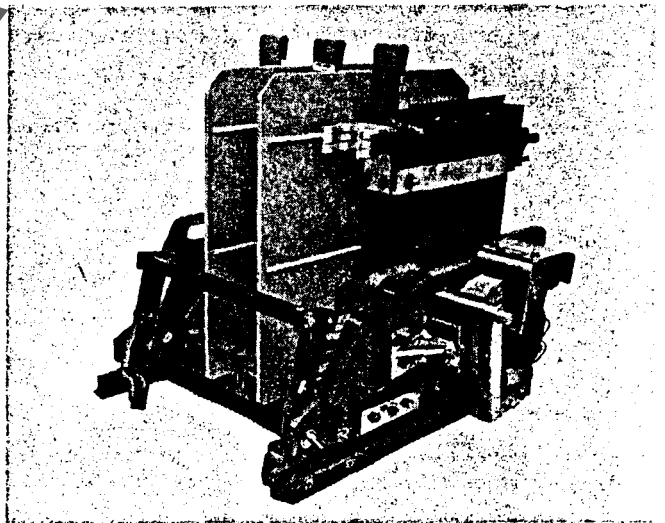

Fig. 1B. IC2814E220 three-high contactor less power fuses

## DESCRIPTION

The IC2814E210 thru E241 and E620 thru E671 are 400-ampere contactors with features and voltage ratings listed in Table 1.

The IC2814E510 thru E541 and E720 thru E771 are 200-ampere contactors with features and voltage ratings listed in Table 1.

[www.ElectricalPartManuals.com](http://www.ElectricalPartManuals.com)

## GEH-3102C, High-voltage Ac Contactors

The IC2814E411 thru E451 are 700-ampere contactors with features and voltage ratings listed in Table 1. Refer to pages 26 and 27 for special description of these contactors.

The IC2814E250, E251, E551 and E451 contactors are essentially versions of the IC2814E220 thru E241, E520 thru E541 and E421 contactors with 3 normally open (NO) and 3 normally closed (NC) electrical interlocks mounted on the magnet side of the contactor as shown in Fig. 5.

The IC2814B211 contactor (see Fig. 55 and 56, page 31) has 3 NC poles and is used primarily in dynamic braking applications. The contactor can only be used to make or establish an electrical circuit. Since it does not have blow-out coils and arc chutes, the contactor should not be opened with current flowing. Refer to special section (page 31) for maintenance instructions.

Contactors that are used in Limitamp® equipment that meets Underwriters Standard 347 are shown in Fig. 2A and 2B.

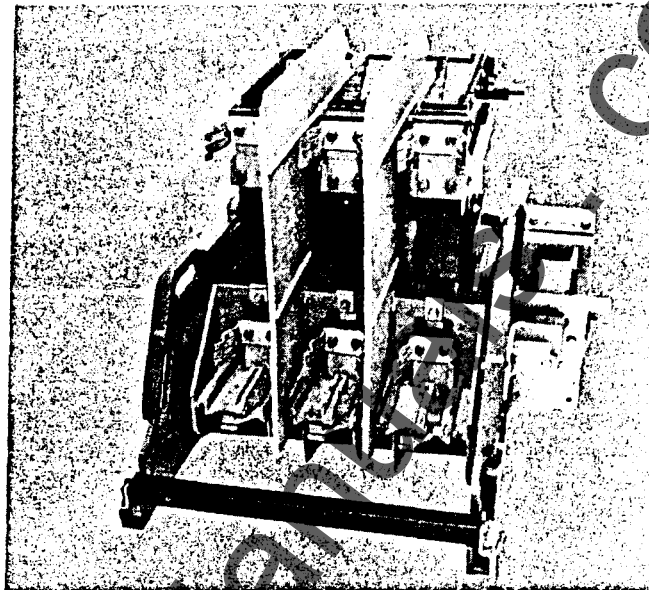

Fig. 2B. IC2814E220 three-high contactor for Limitamp that meets Underwriters Standard 347

The two forms of contactors are basically the same with the following exceptions. The one-high contactor has five-inch diameter wheels and intermediate power voltage stabs (see Fig. 1A). The three-high contactor has a positioning handle and intermediate control voltage stabs (see Fig. 1B).

Contactors having different nameplate stamping but which are mechanically the same are not directly interchangeable. If two contactors are to be interchangeable, their respective nameplate stamping must be identical.

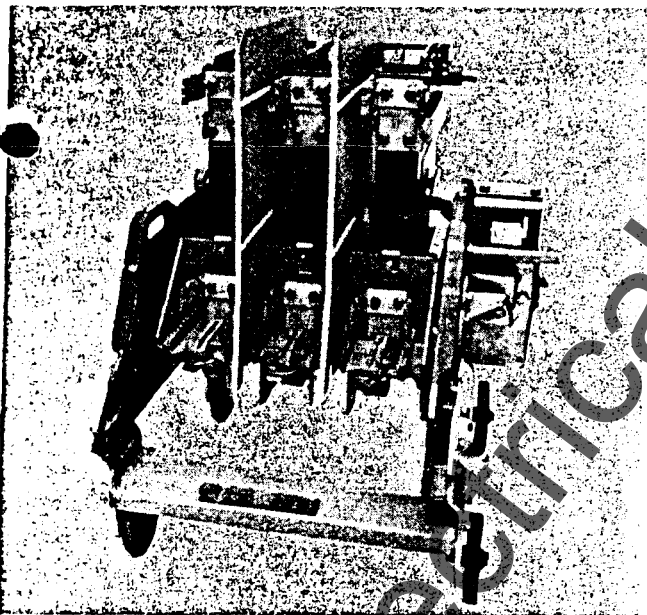

Fig. 2A. IC2814E220 one-high contactor for Limitamp that meets Underwriters Standard 347

All standard contactors, except the IC2814E211, have 3 normally open (NO) poles and have stab connections for both power and control voltages. When these contactors are rolled or slid into their enclosure, all power and control connections are made automatically.

Since these contactors were designed primarily for use in the IC7160 limitamp controller, two basic forms of contactor for each catalog number were designed. One form for use in the one-high enclosure as shown in Fig. 1A and one for use in a two- or three-high enclosure as shown in Fig. 1B.

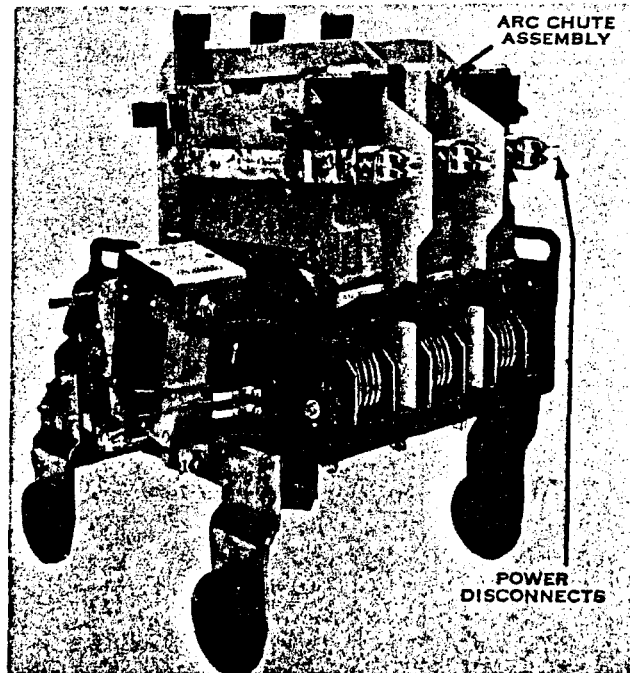

Fig. 3. IC2814E220 one-high contactor showing power-disconnect assembly in its closed position

[www.ElectricalPartManuals.com](http://www.ElectricalPartManuals.com)

With the exception of the IC2814E210, E211, E510, E511 and E411, power can be removed from the contactor by moving the power-disconnect fingers, located on the archute assembly, as shown in Fig. 3, out of engagement with the vertical bus. This is done by rotating the complete archute assembly or by moving the complete contactor.

By means of a mechanical interlock arrangement in the enclosure, the contactor must be in its de-energized position before the disconnect assembly can be operated.

**CAUTION:** *The disconnect assembly is a non-load-break device and must not be operated with any current flowing.*

With the exception of IC2814E250, E251, E550, E551 and E451, the contactors do not have auxiliary electrical interlocks. The interlocks for these contactors are located in the IC7160 enclosure as shown in Fig. 4.

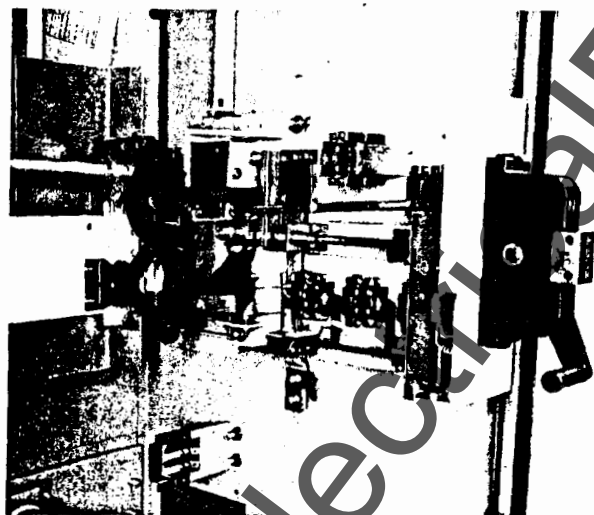

Fig. 4. Isolation switch and electrical interlocks of IC7160 Limitamp which utilizes IC2814 contactors

Although these contactors were designed for Limitamp® forms with special features such as bolted connections, counterweight, etc. are available.

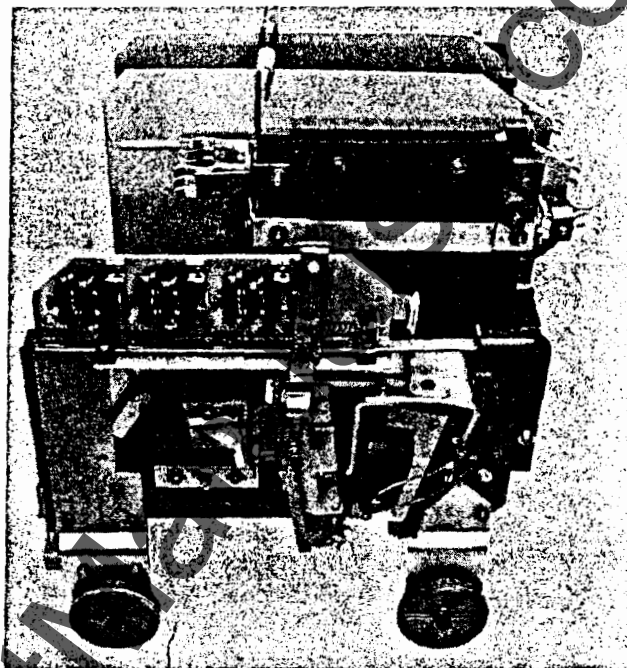

Fig. 5. IC2814E250 with interlock mounted

#### LATCHED CONTACTORS

A latch as shown in Fig. 5A can be furnished with all contactors so that they can be mechanically held closed. Latches are available to allow the contactor to be closed and opened both electrically and manually, or combinations of these functions.

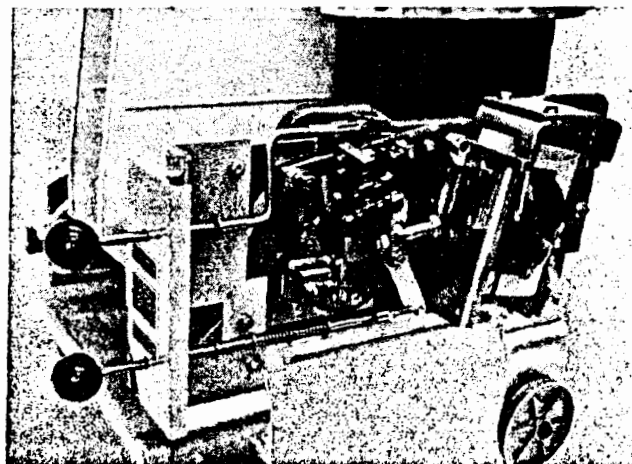

Fig. 5A. Latch mechanism with manual close and release

[www.ElectricalPartManuals.com](http://www.ElectricalPartManuals.com)

# GEH-3102C, High-voltage Ac Contactors

## ANTI-SINGLE-PHASE MECHANISM

All contactors with bolted fuses can be supplied with an anti-single-phase trip-bar which offers single-phasing protection resulting from a blown fuse (see Fig. 5B).

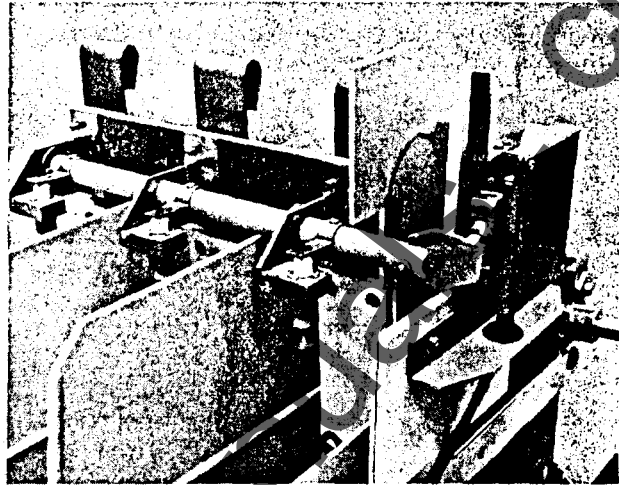
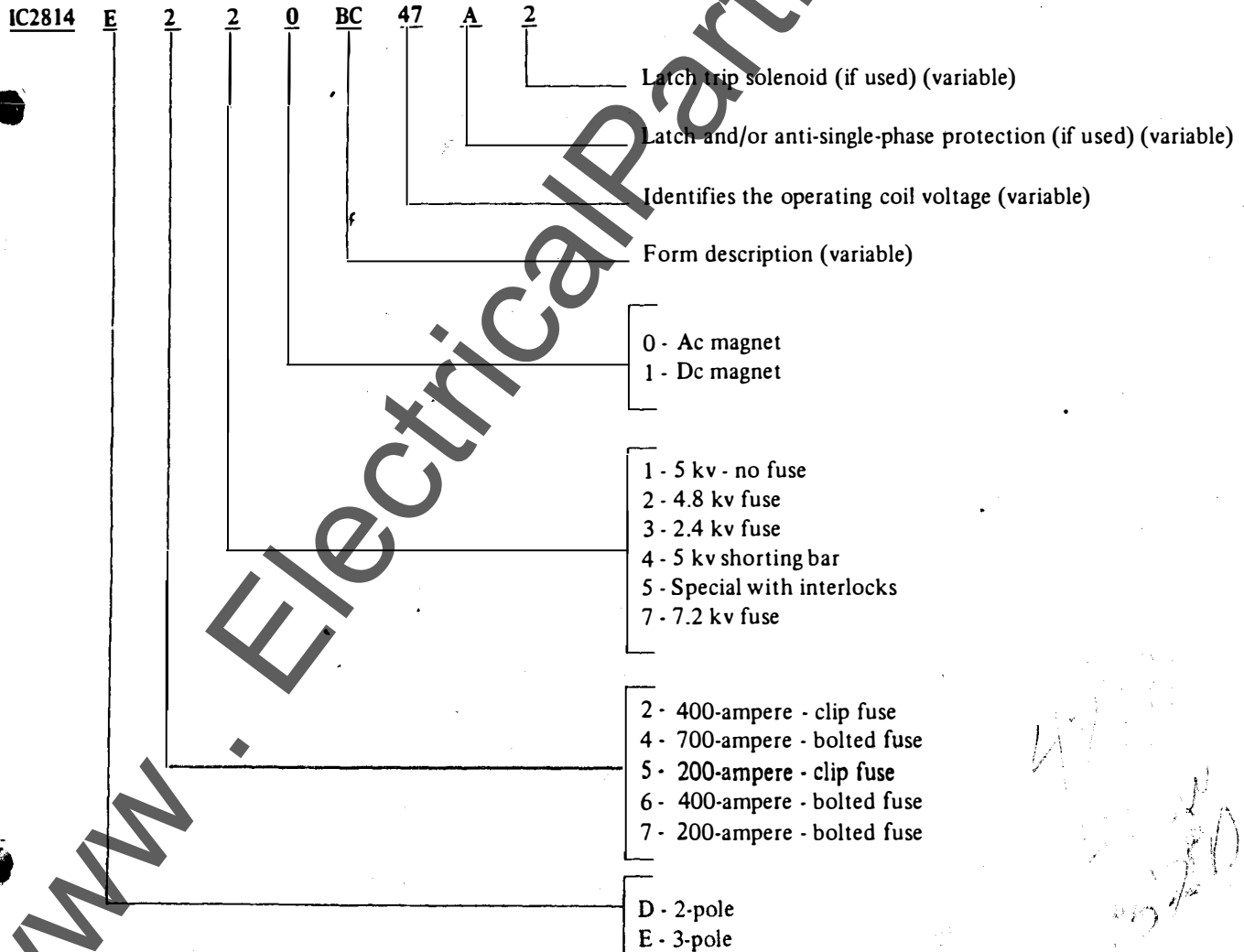

Fig. 5B. Anti-single-phase mechanism

## NOMENCLATURE DESCRIPTION

The contactors can be identified through the nomenclature description, a sample is shown below.



[www.ElectricalPartManuals.com](http://www.ElectricalPartManuals.com)

## CONTACTS

The contacts (see Fig. 6 and 6A) are provided with a special facing which will assist in properly making, carrying and interrupting electrical power. This facing also gives additional life through its ability to resist erosion during making and breaking of electrical power. It is imperative that the contacts be replaced before any part of one contact makes contact with the base material of its mating contact. The special facing reduces loss of facing material during making and breaking electrical power.

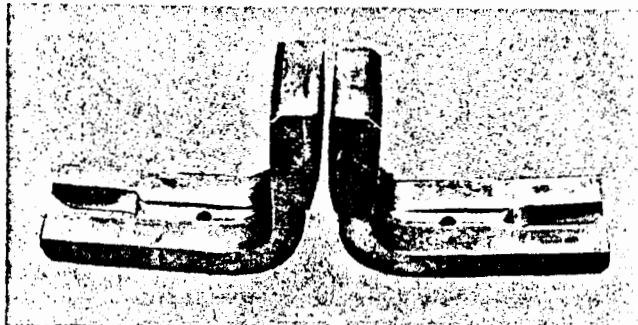

Fig. 6. 400-ampere power tips

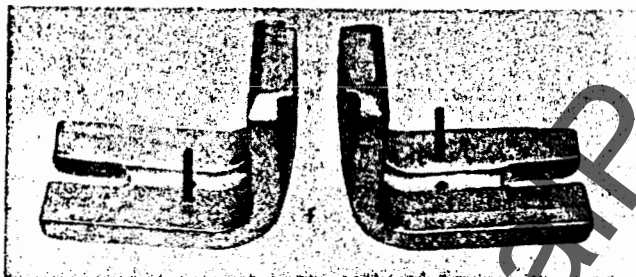

Fig. 6A. 700-ampere power tips

## OPERATING MAGNETS

The ac magnets have continuously rated coils. The dc magnets have intermittently rated coils with a holding resistor.

Control voltage for energizing the coils should be within 85 to 110 percent of the control voltage rating of the ac coils - 80 to 110 percent of the control voltage rating of dc coils.

Voltage less than the minimum will result in poor pickup and possible contact welding; voltage higher than the maximum will greatly decrease the coil life and, in the case of ac magnets, cause the armature to pound the magnet severely. The pounding will result in misalignment, overheating, decreased contact life, etc.

Magnets and coils are designed for a 40 C ambient. If operated at much higher temperature, coil life is greatly reduced and defective operation could occur. Special coils for higher voltages and temperatures can be supplied if required.

## DISCONNECT ASSEMBLY

The disconnect assembly for these contactors is a complete unit containing arc chutes, power disconnects, power fuses, intermediate power or control stabs, grounding straps, interphase barriers, and operating shaft assemblies (see Fig. 7). This assembly is mounted on the contactor in such a manner that it can rotate. It can be rotated into positions shown in Fig. 8 for inspection or service of the contactor.

When the contactor is pushed into a Limitamp® enclosure, the operating shaft assemblies engage the isolation switch operating mechanism (see Fig. 4). Then when the switch handle is pushed into the ON position, the disconnect assembly is rotated so that the power disconnects engage the vertical bus.

Other electrical manufacturers connect or disconnect the contactor to the power bus by moving the complete contactor assembly in or out of the stab position.

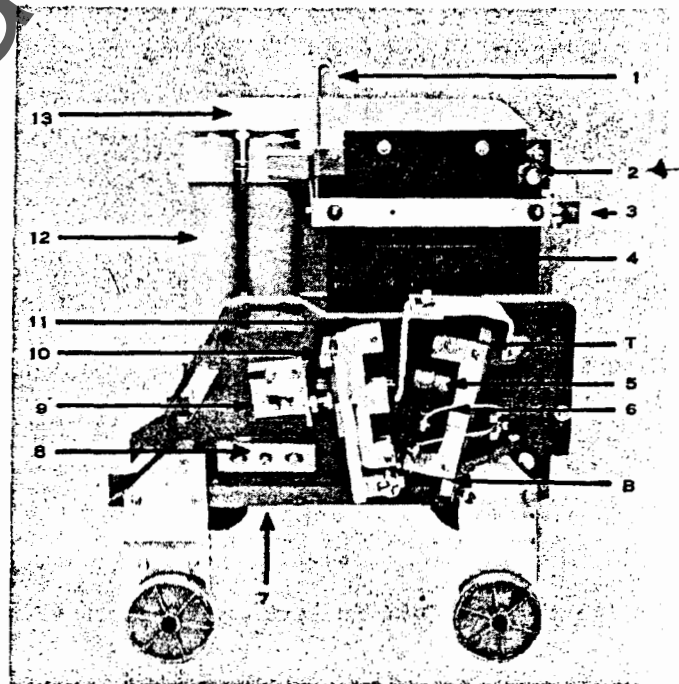

- |                     |                                  |
|---------------------|----------------------------------|
| 1—GROUND STRAP      | 8—STUB SHAFT                     |
| 2—OPERATING SHAFT   | 9—ARMATURE STOP                  |
| 3—POWER FINGER      | 10—ELECTRICAL INTERLOCK OPERATOR |
| 4—ARC CHUTE         | 11—MOVEABLE ARMATURE             |
| 5—COIL              | 12—FUSES                         |
| 6—STATIONARY MAGNET | 13—INTERPHASE BARRIER            |
| 7—INTERMEDIATE STAB |                                  |

Fig. 7. IC2814E220 showing magnet and disconnect assembly

[www.ElectricalPartManuals.com](http://www.ElectricalPartManuals.com)

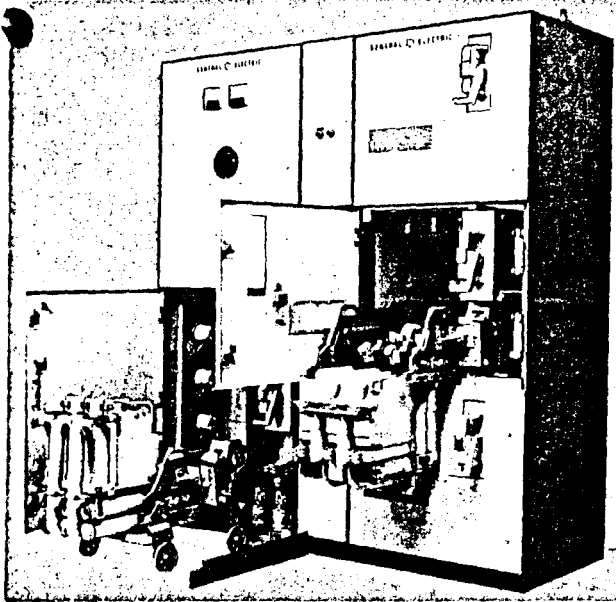

Fig. 8. One-high and three-high contactors in service position

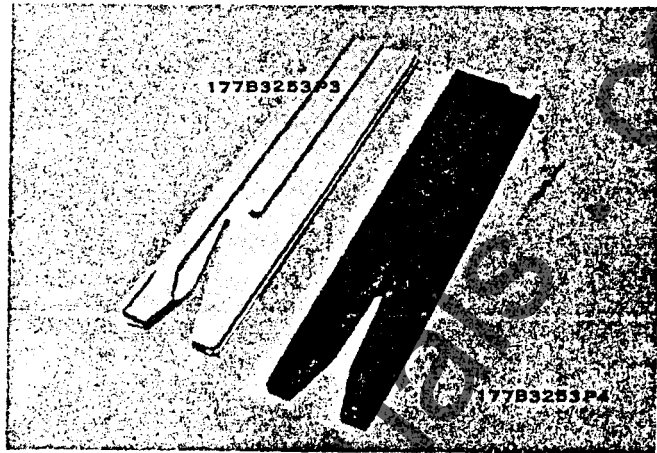

Fig. 9A. Comparison of arc barriers

## 2. Ceramic - 177B3253 P3 and P4

These vanes are light tan and consist of two different parts. One part has a "V" slot that is canted to the right, as shown in Fig. 9B. When these two parts are assembled into an arc chute, they are assembled alternately so that the "V" of a particular vane veers in the opposite direction of the "V" in the vane adjacent to it. These vanes can be used in any contactor, but are required in all contactors with a voltage rating above 5000 volts, all 700-ampere contactors regardless of voltage, and containers which meet UL Standard 347.

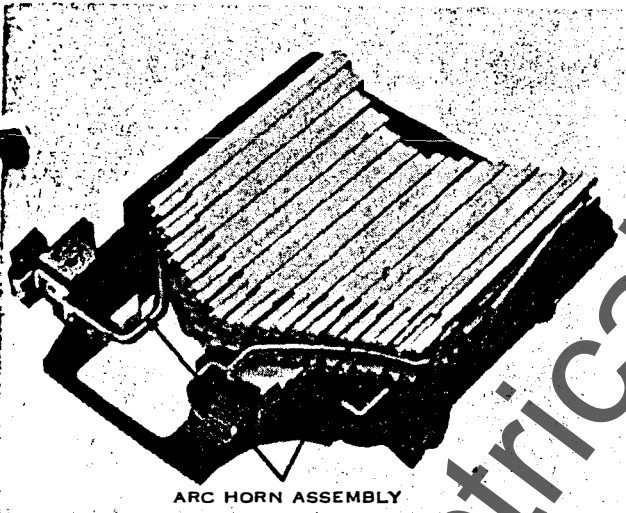

Fig. 9. Open view of arc chute showing vanes and arc horns

## ARC CHUTES

The individual arc chutes contain replaceable vanes and arcing horns (see Fig. 9). Two different kinds of vanes and two different kinds of arc horns are available. The description of each is listed below:

### Vanes

#### 1. Molded Compound - 106B9931

These vanes are light gray and have a "V" on the centerline of the part as shown in Fig. 9A. These can be used in any 200- or 400-ampere contactor with a voltage rating up to and including 5000 volts.

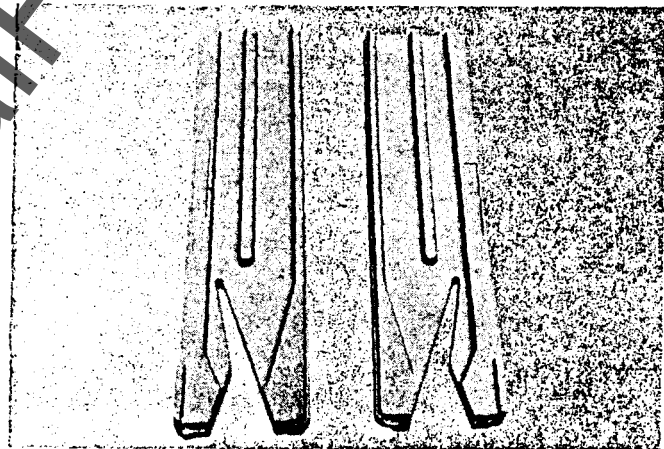

Fig. 9B. Ceramic vanes 177B3253P3 and P4

### Arc Horns

#### 1. Standard

These arc horns as shown in Fig. 9 are used in all 200- and 400-ampere contactors with voltage ratings up to and including 5000 volts.

#### 2. Coated

These arc horns have a coating of special material which aids interruption. These arc horns are required for all 700-ampere contactors and all contactors with a voltage rating above 5000 volts.

[www.ElectricalPartManuals.com](http://www.ElectricalPartManuals.com)

If the contactor is used in a humid atmosphere, or if moisture is present in its vicinity, space heaters are recommended to keep the arc chutes dry, since moisture limits the interruption ability of the arc chutes.

It is not necessary to replace vanes that are cracked. Cracked vanes do not effect the operation of the contactor provided no parts are loose and fall out.

## POWER AND CONTROL DISCONNECTS

Power disconnects (see Fig. 3) are provided so that contactors can be removed or installed in enclosures without having to disconnect or connect cables. Control disconnects are also provided for this same purpose.

Figure 11 and 12 show the location of the power stabs and fingers, as well as the control disconnect fingers, with reference to the contactor side or wheels.

No lubrication is required on any of these disconnects, but if desired, General Electric Contact Lubricant D50 H47 can be applied to the power-disconnect stabs. Do not apply this lubricant to the control disconnect fingers.

## FUSE CLIPS (Contactors with fuse clips)

Fuse clips on the arc-chute assembly must hold the fuses very securely. Fuses must enter the clip with a force of 20 pounds exerted on each end of the fuse. This can be assured by maintaining the setting of the "U" clip of the fuse clips to a 3.10-inch  $\pm$  0.25-inch dimension (see Fig. 10).

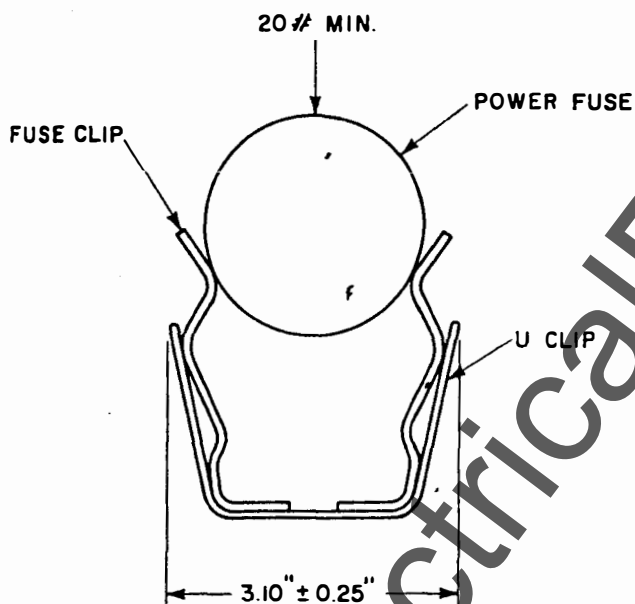

Fig. 10. Force for inserting power fuses into fuse clip

## INSTALLATION

For convenience and safety in lifting or moving the contactor, a lifting device as shown in Fig. 13 should be purchased. It is not intended that the lifting device should be used as a means of transporting the contactor in the raised position. The contactor should be transported with the lifting device in its lowered position.

If the contactor is not installed in a metal enclosure, at least eight to ten feet of arcing clearance in front of the unit is advised for protection of personnel.

Observe the following precautions before applying power to the contactor for the first time.

1. Remove the shipping supports, blocks, or ties used for protecting the contactor in transit.

[www.ElectricalPartManuals.com](http://www.ElectricalPartManuals.com)

NOTE: All dimensions in inches.

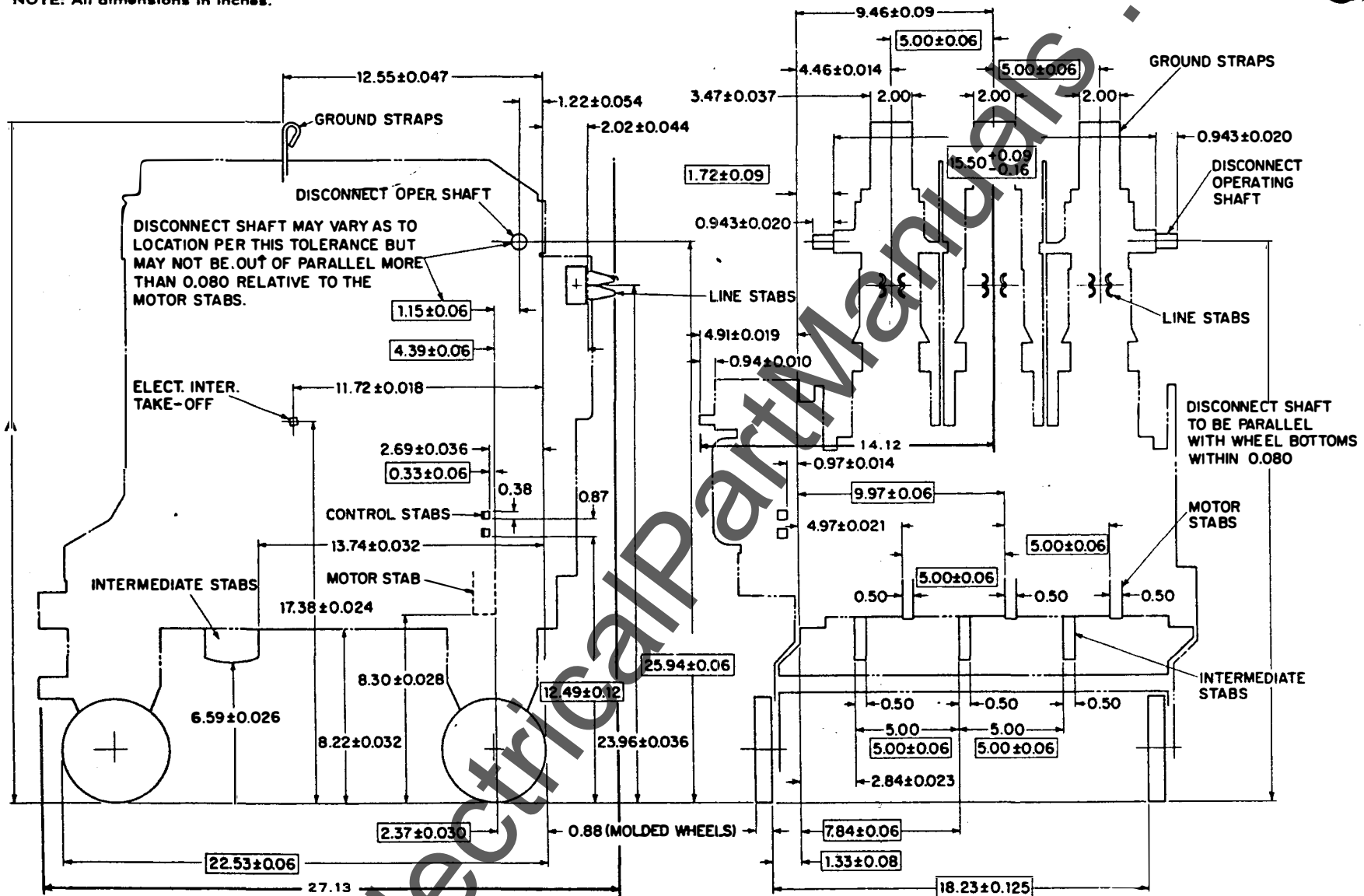

The dimensions in the boxes are those that are most critical.

REAR VIEW

DIMENSION	CONTACTOR DESCRIPTION
31.88	ALL 200- AND 400- AMPERE CONTACTORS WITH CLIP FUSES
36.62	ALL CONTACTORS WITH BOLTED FUSES

GEH-3102C, High-voltage Ac Contactors

Fig. 11 Outline of high-voltage contactor showing location of power stabs and control stabs (one-high contactor)

[www.ElectricalPartManuals.com](http://www.ElectricalPartManuals.com)

NOTE: All dimensions in inches.

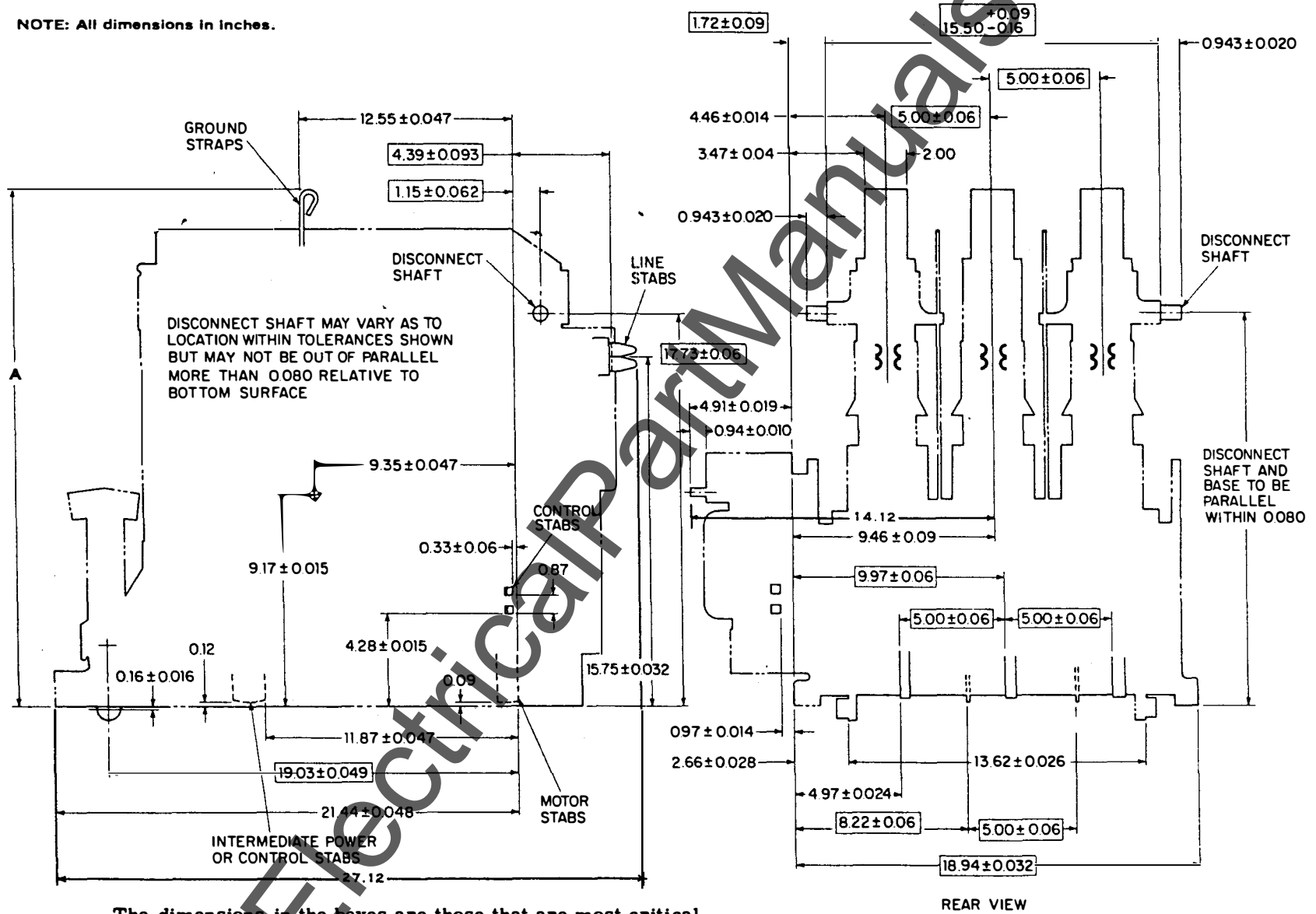

The dimensions in the boxes are those that are most critical.

DIMENSION	CONTACTOR DESCRIPTION
23.67	ALL 200- AND 400- AMPERE CONTACTORS WITH CLIP FUSES
28.40	ALL CONTACTORS WITH BOLTED FUSES

Fig. 12. Outline of high-voltage contactor showing location of power stabs and control stabs (three-high contactor)

[www.ElectricalPartManuals.com](http://www.ElectricalPartManuals.com)

## GEH-3102C, High-voltage Ac Contactors

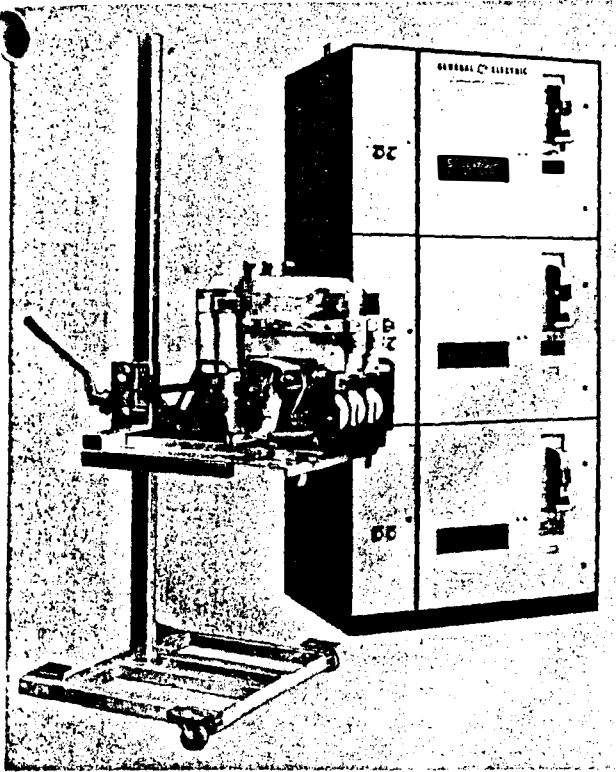

Fig. 13. A lifting device should be used to assure safe handling of the contactor during moving

and should be quiet. Ac magnets will have an ac hum, but should not make an appreciable noise. Appreciable noise would indicate magnet misalignment; therefore the magnets should be aligned according to the "Ac Magnet Assembly" section of "Maintenance" instructions.

8. Rotate the disconnect assembly to insure that when the arc chute enters between its mating pole pieces, a gap of 1/8 inch is maintained between the chute and pole pieces. Also, the interphase barrier should clear the hardware mounting the pole pieces to the blowout core by 1/8 inch.

## MAINTENANCE

The following instructions are applicable to all contactors, but it should be noted that some special instructions apply to 700-ampere contactors. Refer to special section "Models IC2814E411 thru E451," page 26.

Special instructions for the IC2814B211 can also be found in special section "Model IC2814B211," page 31.

Refer to special section "Latched Contactors," page 28, for instructions relative to the latch mechanism.

This electrical apparatus will provide maximum trouble-free service if given the benefit of inspection, preventive maintenance, and periodic cleaning. It is important that a definite inspection schedule be maintained. The frequency of the inspection periods will depend upon the operating conditions.

Contact life depends on the severity of service required for the device. The contactor should be thoroughly inspected after every 50,000 operations, or more often if operated very infrequently.

## INSPECTIONS

Move the contactor to its service position as shown in Fig. 8. To place disconnect assembly of the three-high contactor into its inspection position, it is necessary to first remove the special positioning handle.

In these routine inspections, check for the following per the reference instructions: (Reference instructions are in parenthesis and can be found in later pages of these instructions under the same heading.)

1. Loose screws, nuts and bolts.

2. Loose electrical interlocks - ("Electrical Interlocks—IC2814E250, E251, E550, E551, and E451 Models").

2. Carefully inspect all parts of the contactor. Operate it by hand to see that all parts work freely. Be sure that the contacts strike squarely with their sides in line within 0.09 inch. Remove foreign objects or matter which may have collected in the magnet or tip gaps during transit or storage.

3. Remove any protective grease or oil which may be on the magnet face, as the grease could collect dust and dirt, thus causing a sticking of the magnet.

4. See that all parts of the contactor are clean. High-voltage equipment fails if too much dirt accumulates.

5. Check the arc chutes according to the "Arc Chute" sections of "Description" and "Maintenance."

6. With the power disconnect assembly in its closed position (see Fig. 3), operate the magnetic armature assembly by hand again to see that all parts operate freely and that moving parts do not rub on the arc chutes.

7. Operate the contactor electrically with the disconnect assembly in the closed position. This is accomplished by connecting rated control power to the control disconnect fingers. The proper picking-up of the contactor can thus be checked. At rated coil voltage it should pick up completely until the stationary and movable magnets hit

[www.ElectricalPartManuals.com](http://www.ElectricalPartManuals.com)

3. Accumulation of dust and foreign material such as coal dust, cement dust or lamp black. This material must be periodically blown off the contactor if inspection shows any accumulation. The blowout base must be wiped clean at regular intervals, as dust collects moisture and can cause a voltage breakdown.

Dust accumulation on the arc chutes is detrimental for the same reason.

4. Contacts should be checked for general condition and replaced if necessary – (“When to Replace Contacts” and “Contact Alignment”).

5. Ac magnets (Item 1, 2, 3, 4 and 7 of “Ac Magnet Assembly”).

6. Dc magnets (“Dc Magnet Assembly”).

7. Loose bolted connections – Hardware at connection points must be assembled securely at all times.

8. Collars on each side of the movable power tip shaft next to the bearing blocks should be set for 0.030- to 0.050-inch side play of the shaft, and still allow for proper alignment of the power tips and magnet assembly.

If the contactor has been required to interrupt power above its rated interruption capacity, or has interrupted power without pertinent adjustments per these instructions, and/or the contactor has been operating for a year since the last thorough inspection, the following checks must be made:

1. Contact forces must be measured directly per Table 2 and the springs replaced if the forces are not within limits.

2. Contacts should be inspected (“When to Replace Contacts” and “Contact Alignment”).

3. Arcing-horn assemblies – (“Arcing Horn Assemblies and Pole Pieces”).

4. Arc Chutes – (“Arc Chutes”).

5. Dc Magnets – (“Dc Magnet”).

6. Electrical interlocks – (“Electrical Interlocks– IC2814E250, E251, E550, E551 and E451 Models”).

7. Power disconnects – (“Power Disconnects”).

8. Fuse Clips – (“Fuse Clips”).

9. Shaft bearings – Shaft bearings do not require lubricant during the life of the contactor.

## CONTACTS

### When To Replace Contacts

The contacts will be pitted and show various shades of black after considerable usage. The pitted-contact surfaces are characteristic of ac applications and will not interfere with proper operation as long as proper contact pressures are maintained per Table 2. If the contacts are wearing away with the contacts misaligned more than 0.09 inch, the contacts should be replaced, as the misaligned condition can only get worse and accentuate the wear of the bearing hole in the bronze movable-contact support.

Outlined below is the proper method for determining when it is necessary to replace contacts:

1. (See Fig. 14 and Fig. 15.) With the contacts just touching, measure the magnet gap “A” per Fig. 15. If the gap is less than 0.23 inch, replace both the movable and stationary contacts. Contacts not replaced at this time may overheat or weld together. Wedge the top of the armature away from its supporting bracket as far as it will go (see Fig. 15) when measuring the “A” dimension.

2. The contacts must also be replaced if misalignment as mentioned above exists.

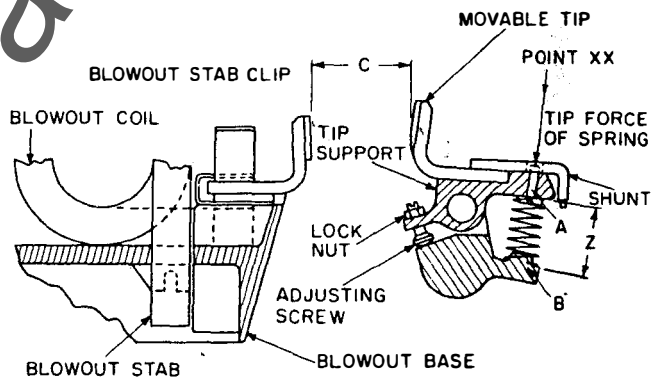

Fig. 14. Movable and stationary contact structures

TABLE 2 CONTACT DIMENSION

Contactor Description	"A" Dimension (wiper) Fig. 15 Contacts just touching See Note 1		Contact Forces See Note 2	
	New Contacts (Inches)	Replace when measurement "A" reaches (Inches)	Initial Contacts Open (Pounds)	Final Contacts Closed (Pounds)
All 200- and 400-ampere contactors with voltage rating up to and including 5000 volts	0.47 ±0.03	0.23	23 - 31	28 - 36
All 200- and 400-ampere contactors with voltage rating above 6000 volts	.47 ±0.03	.23	32 - 39	58 - 71
All 700-ampere contactors	.47 ±0.03	.23	66 - 74	100 - 116
IC2814B211	Refer to Special Section for IC2814B211			

NOTES: 1. Measure per section on "When to Replace Contacts".  
2. Initial force is the force in direction of arrow at "XX" that will just start the movable contact in motion. Final force is the force in the same direction at "XX" that will just part contacts when they are fully closed.

[www.ElectricalPartManuals.com](http://www.ElectricalPartManuals.com)

## Contact Alignment

The contacts are adjusted to make at the same time within 1/64 inch. When replacing the contacts, check this adjustment by picking up the contactor mechanically until the contacts of the first pole are just touching each other. The maximum gap between the contacts of any other pole of a contactor must not exceed 1/64 inch. Adjust the movable-contact position to obtain this requirement as well as the wipe per Table 2, by means of the set-screw in each movable-tip support. The set-screws should be locked in their final position by means of their locknuts (see Fig. 14).

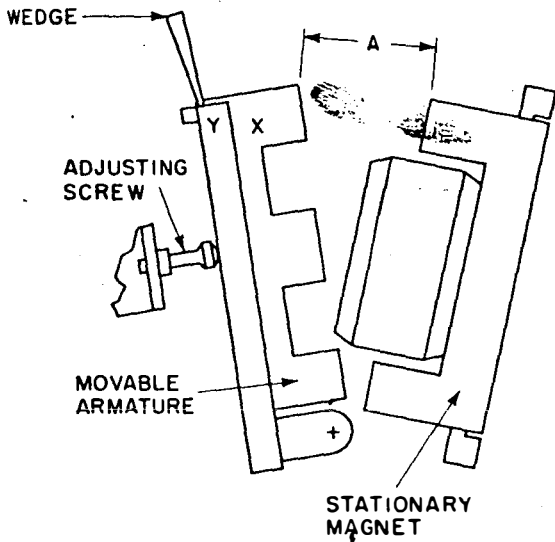

Fig. 15. Magnet structure (ac and dc)

The angular position of one contact with reference to the other, when they first touch each other and with the contactor fully closed, is not critical as the special facing for each contact substantially assists the contacts in making, carrying, and interrupting electrical power. Their relative positions with reference to each other may also change considerably during the life of the contacts.

The contacts of a pole must also make with the back surfaces approximately parallel per Fig. 16. The contacts must also be aligned from left to right within 0.09 inch maximum per Fig. 17. These requirements must be met to increase the life of the contacts and movable-contact supports. These requirements will be present also with replacement contacts unless the alignment of the pole assembly has been disturbed.

The main shaft assembly can be moved left to right slightly to help obtain these requirements.

## Measuring Contact Forces

Open the disconnect assembly to its service position; the contact forces, per values given in Table 2 can

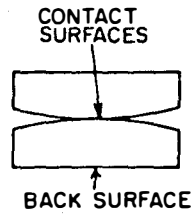

Fig. 16. Contacts with back surfaces parallel

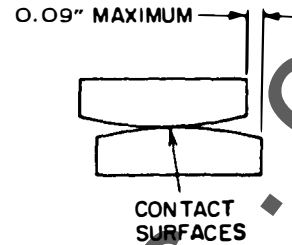

Fig. 17. Maximum sideways misalignment of contact surfaces

then be easily measured directly over the spring seat as shown in Fig. 14.

Initial contact force will be maintained if the "Z" dimension between A and B on the spring's centerline is  $1.68 \pm 0.06$  inch. Final contact force will be maintained if the "Z" dimension, when the magnet is fully closed, is  $1.52 \pm 0.06$  inch. This dimension "Z" applies to all ac and dc magnets.

Contact gap "C" (see Fig. 14) must be 1.00 inch per Table 2. The "C" dimension can be obtained by slightly moving the back-stop adjusting screw. When the "A" dimension with tips fully open and just touching and the "C" gap are obtained, the initial and final contact forces should be properly set without further adjustment.

## Replacing Contacts (200- and 400-ampere only) (See special Section for 700-ampere)

1. Rotate the disconnect assembly to the service position (see Fig. 8).
2. Rotate the pole pieces out of position as shown in Fig. 18.

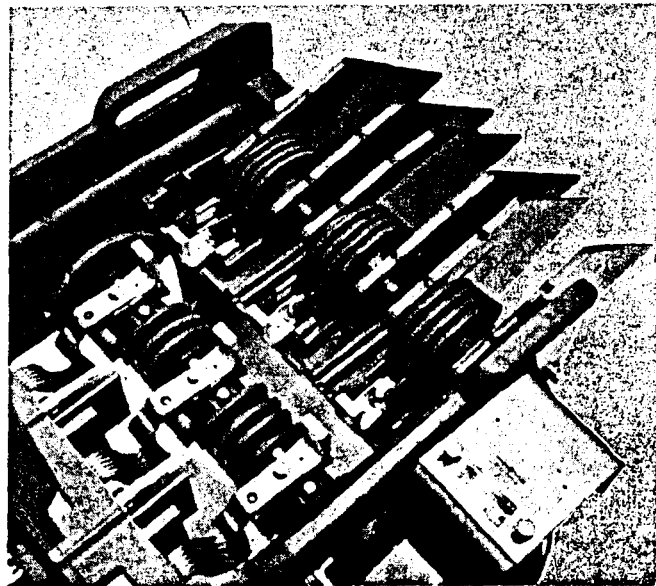

Fig. 18. Contactor open with pole pieces rotated out of position

[www.ElectricalPartManuals.com](http://www.ElectricalPartManuals.com)

3. With a socket wrench, loosen bolt securing contact. Since the contact is slotted (see Fig. 6) raise the contact to clear the locating pin as shown in Fig. 19. When loosening the bolt, on the stationary contact, care should be taken so that the dimension across the arc-horn stab is not disturbed. Do not remove bolts.

4. To replace the movable contact, lift up the shunt and slide the tip into place. Make sure the hole in the contact engages the previously mentioned locating pin.

5. To replace the stationary contact, slide the contact between the blowout-coil pad and the arc-horn stab. Make sure the hole engages the locating pin.

6. After new contacts have been securely fastened, check to make certain contact gap, wipe, and alignment are correct.

7. Check to make certain that the screw used as a spring seat for the movable contact spring is tight. The shunt terminal should tend to angle away from the magnet structure. This will insure that the shunt will flex properly during operation. Shunt shape should never be altered manually.

8. Rotate the pole pieces back to their proper position before disconnect assembly is rotated back to its proper position.

It is recommended that both contacts of a pole be replaced at the same time. If only one contact (movable or stationary) is replaced, the electrical current make and carry ability of the pair of contacts will be impaired.

### Replacing Contact Springs

The contact springs (see Fig. 19) must be replaced if they have been overheated from interruptions above the contactor ratings or damaged from rough handling. Contactors having contact springs with a grayish-black color should have the contact pressures checked per Table 2 as they have probably been overheated. Any initial and final contact forces outside of those of Table 2 will require that the springs be replaced. These spring forces are necessary to allow the contactor to properly make, carry, and interrupt electric power.

To replace a contact spring, remove the movable-contact assembly from the shaft by loosening the hardware shown in Fig. 19.

### ARC-CHUTE ASSEMBLY

The arc chutes on this contactor are a unit that has mounted to it power fuse clips, grounding strap and power disconnects (see Fig. 20).

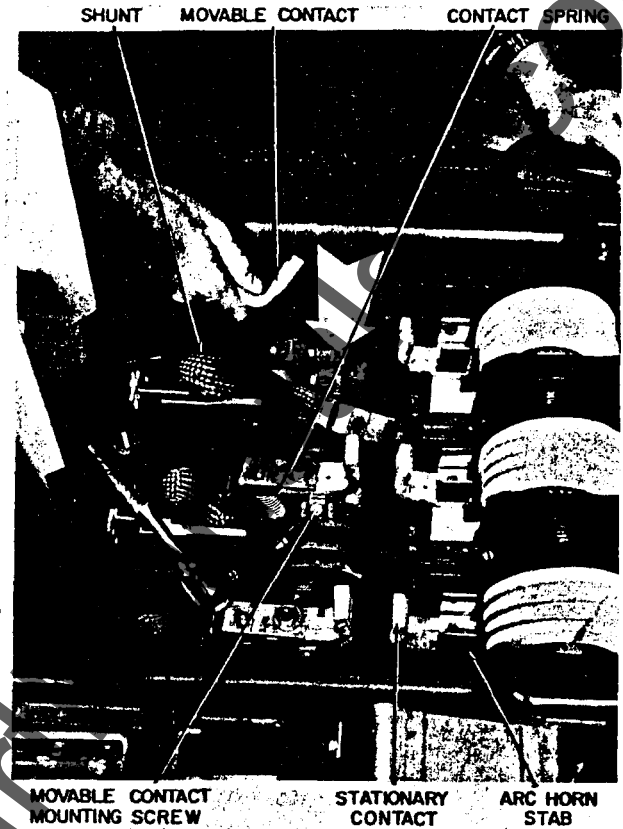

Fig. 19. Contactor open for servicing. Arrow points to pin for locating power contacts

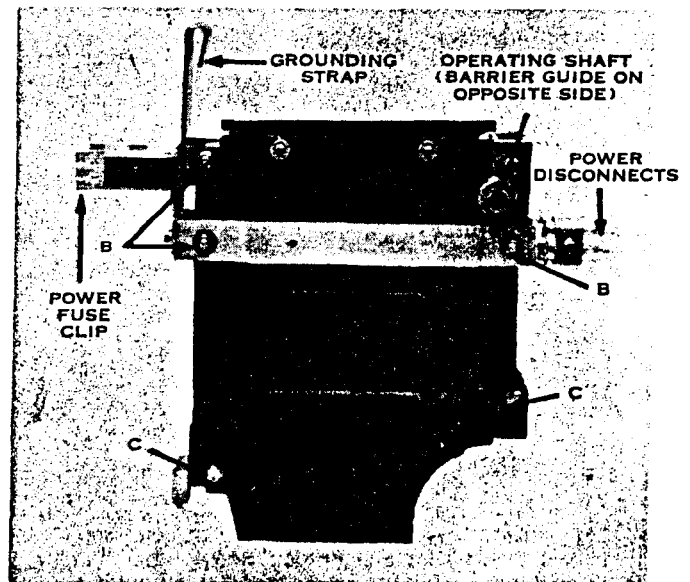

Fig. 20. Arc-chute assembly with power fuse clip, grounding strap and power disconnects

[www.ElectricalPartManuals.com](http://www.ElectricalPartManuals.com)

## GEH-3102C, High-voltage Ac Contactors

The arcing horns, as shown in Fig. 9, are built into the arc-chute sides. Arc-horn assemblies should never have to be replaced except for mechanical damage. Spatter of arc-horn material onto insulation strips should be removed after every 50,000 operations or more often if the contactor is frequently interrupting at high currents. To aid in inspecting for spatter, remove the vanes from the arc chute and look into the chute.

Any spatter on the ends of the arc horns near the contacts must be removed to maintain the 1/8-inch minimum spacing between the contacts and arc horns. A chisel or file is a satisfactory tool for this cleaning operation. Salient points formed on the arc-horn ends near the contacts should be removed because they may allow electrical charge build-ups which can cause voltage breakdowns across the horns.

After the contactor has been required to interrupt power above its rated interruption capacity, or has interrupted power without proper pertinent adjustments in accordance with these instructions, the following checks must be made:

1. The arc barriers or vanes inside the arc chutes must be checked for excessive gutting from the arcing at the "V" notches. Excessively gutted vanes, those having enlargements 1/4 inch or greater, must be replaced.
2. The vanes should be checked for continuous beads resulting from the gutting which makes a continuous path across more than a few vanes (3) of the arc chute. (see Fig. 21). These beads offer a current-conducting path which reduces the length of the interrupting arc. Any vanes with the continuous bead between them must be replaced.

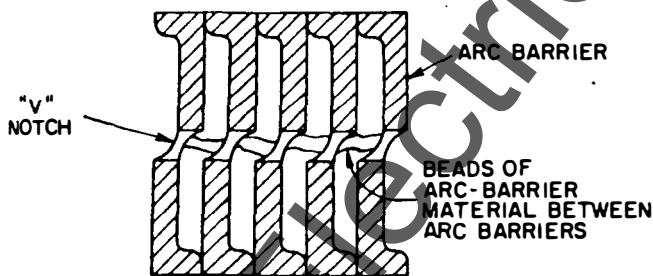

Fig. 21. Arc barriers with connecting beads

Since all vanes are molded, these vanes will vary in overall width and thickness. Therefore, the side play of arc barriers, (see Fig. 22), must not exceed "X" dimension of 0.145 inch. Clearance at "Y" must not exceed the thickness of one barrier.

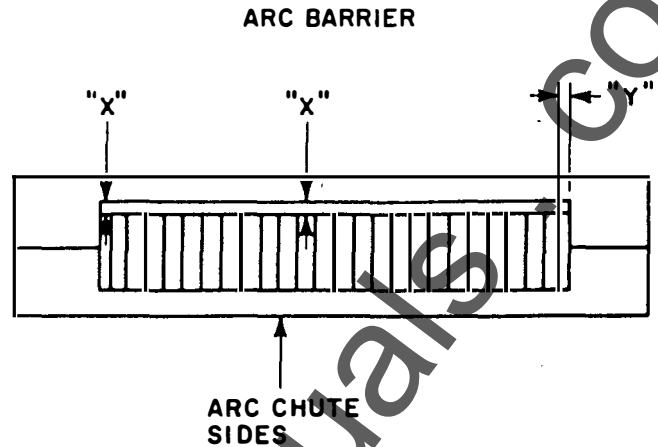

Fig. 22. Arc-chute dimensions

These dimensions will be held on arc-chute assemblies shipped from the factory, but can be exceeded if the contactor interrupts current above the limits or without proper adjustments. "X" dimensions outside the requirements can only be corrected with new arc-chutes sides and/or new arc barriers or by replacing the complete chutes. If the limits of these dimensions are exceeded, hot gasses at high power interruptions will by-pass the arc barriers and limit the arc extinguishing ability.

Should it be necessary to replace arc barriers, the retainer, as shown in Fig. 23 should be removed first. Then the barriers that require replacing can be removed as shown in Fig. 24. Be sure to replace the retainer before putting the contactor back into service.

If replacement of a complete arc-chute assembly is necessary, the following steps are recommended:

1. Remove all arc barriers from the chute to be replaced. This will reduce weight and possibility of damage to the barriers.
2. Remove the bolts that mount the lower power fuse clips and mounting bracket "A" as shown in Fig. 25.
3. Rotate the disconnect assembly to the service position and remove the tie bar (see Fig. 26). Care should be taken to insure that holes in the chute and tie bar that contain roll pins are not damaged.
4. Slide the chute horizontally out of the fuse base assembly.
5. Slide the new chute into position and reassemble the tie bar. Line up holes in tie bar with pins in remaining original chutes, then bolt in place.

[www.ElectricalPartManuals.com](http://www.ElectricalPartManuals.com)



Fig. 23. Removal of arc-barrier retainer

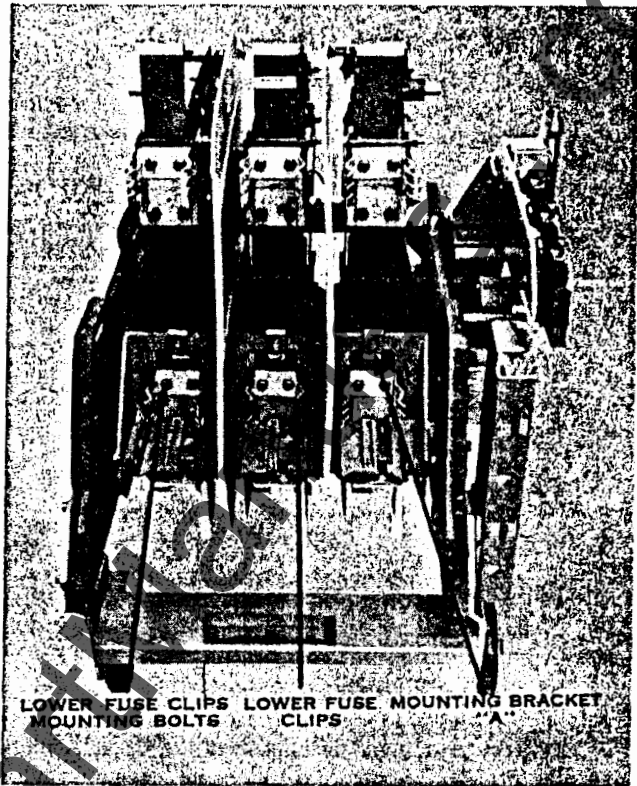

Fig. 25. IC2814E250 contactor

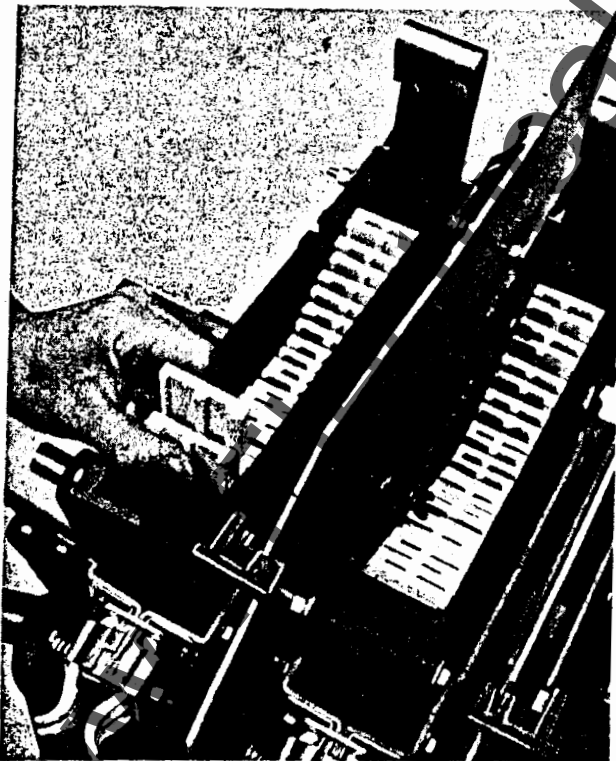

Fig. 24. Removal of arc barrier

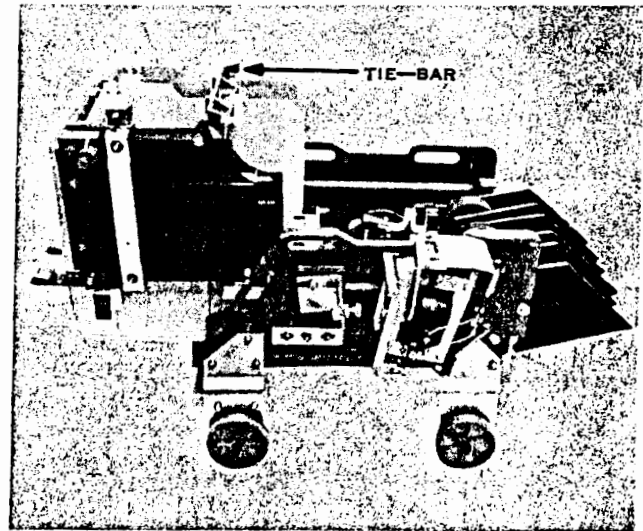

Fig. 26. IC2814E220 contactor with disconnect assembly and pole pieces rotated to the service position

[www.ElectricalPartManuals.com](http://www.ElectricalPartManuals.com)

## GEH-3102C, High-voltage Ac Contactors

6. Rotate complete disconnect assembly to the operating position and reassemble mounting bracket "A" and fuse clips. Note that the connection strap is sandwiched between the phosphor-bronze spring and the fuse clip.

7. Check location of operating shaft (outside chutes only) and power disconnect finger (see Fig. 11 and 12). Then drill and pin tie-bar to the new arc-chute assembly.

8. When the arc-chute assembly is dropped into place, the arc horns must line up within the outer surfaces of their respective contact tips.

9. Insert barriers into the arc chute. Do not apply power to the main contact tips with barriers removed from the chute.

If arc horns or arc chute sides are to be replaced, remove the chute as previously described, then proceed as follows:

1. Remove operating shaft and interphase barrier guide (see Fig. 20). Since these parts are pinned to the chute, care should be taken to insure that parts are not damaged during removal.

2. Remove the hardware at points "B" that mount the clip and stab assembly to the chute. Remove this assembly as a complete unit, so that the power finger assembly will not be disturbed.

3. Remove the "U" shaped insulation at "B" and hardware at "C." (Newer arc chutes do not have this insulation).

4. Open chute and replace parts as required (see Fig. 27).

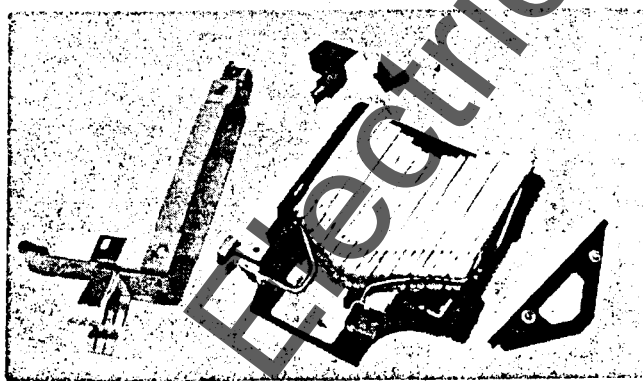

Fig. 27. Components of an arc-chute assembly

5. Replace side. Care should be taken to locate insulation strips, mounted to the arc horns, in slots in the chute side. This can be done by inserting a hand in the open end of the chute and positioning the parts.

6. Replace the hardware at "C" and tighten finger tight.

7. Replace "U" shaped insulation, fuse clip and stab assembly, operating shaft, and the interphase barrier. All hardware should be finger tight.

8. Replace chute assembly on the contactor and make adjustments called for "when replacing" complete chute assembly. Tighten all hardware securely.

9. Adjust the gap across the arc horns to the dimension shown in Fig. 28.

10. Insert arc barriers before applying power to the contactor.

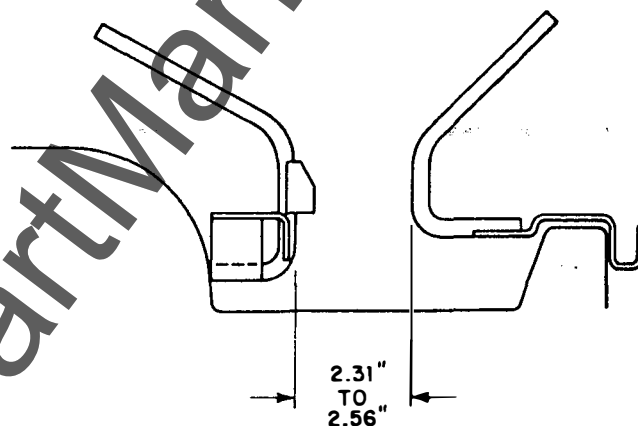

Fig. 28. Arc horn adjustment

### AC MAGNET ASSEMBLY

1. The top and side surfaces of the armature and stationary-magnet frame (see Fig. 29) must be aligned within 1/32 inch. More misalignment will allow the magnets to wear unevenly and must be corrected to give the proper alignment if quiet operation is to be achieved. If the magnet contact surfaces are worn and misaligned more than 1/16 inch, and the magnet is noisy, both the armature and stationary-magnet frame must be replaced. Magnets operating with excessive noise will reduce the life of their operating coils because the picked-up magnet will eventually draw excessive magnetizing current.

2. The contact faces of the armature and magnet frame must seat flush against each other without any rolling action or the magnet will be noisy in operation. Magnet shims between the magnet and contactor frame at "T" and "B" (see Fig. 7) can be changed to obtain proper seating of the magnets.

[www.ElectricalPartManuals.com](http://www.ElectricalPartManuals.com)

3. The armature in picked-up position must have a minimum of 1/64-inch spacing between it and its armature bracket (see Fig. 29). The fulcrum plate must always be assembled with its emboss toward its armature bracket per Fig. 29.

NOTE: All dimensions in inches.

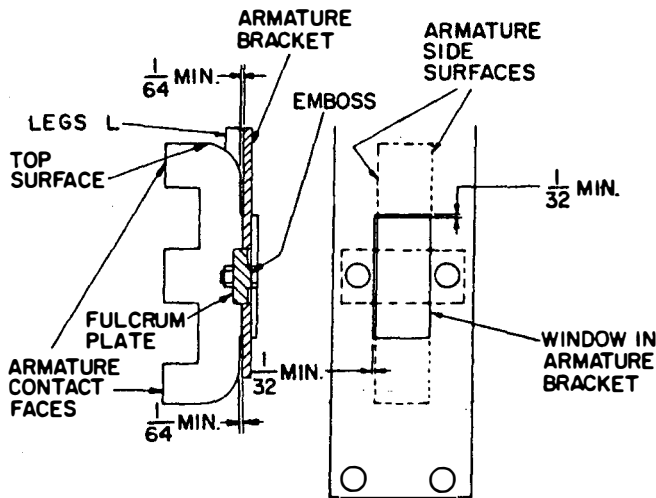

Fig. 29. Ac magnet assembly shown with contactor closed

4. The armature bracket must be assembled to its shaft supporting bracket in such a manner that the armature has a vertical end play in its armature support of 1/32-inch minimum (see Fig. 29). The armature width is such that a side play of 1/32 inch exists. This freedom of the armature in all directions is necessary to allow it to seat properly against the magnet frame.

5. All three contact faces (see Fig. 29) of the magnet frame are machined in the same plane. The outside contact faces of the armature are machined in the same plane. All of these contact faces are machined very accurately with a good finish to allow satisfactory operation. The armature's middle leg is machined 0.003 to 0.007 inch below the plane of the outside leg (see Fig. 30). This machining was done to give magnet life without magnet operating noise.

6. Both magnets should be replaced when the armature legs are worn so that the center leg hits on the center leg of the magnet frame. Both magnets which are worn at all with the misalignment present of Item 1 must also be replaced, as magnets when realigned will have some rolling action present and will be very noisy.

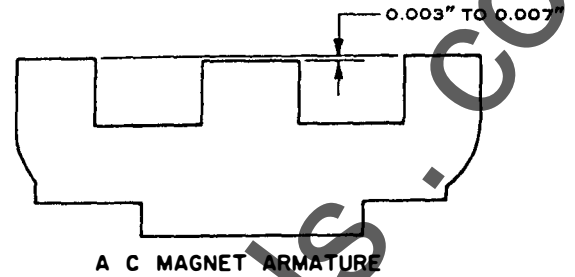

Fig. 30. Ac armature

7. Check to see if one side on the top and bottom of the movable magnet armature is worn more than the other side. This shows that it doesn't have correct clearances per Item 3 and 4 and must be readjusted.

8. Check to be sure that the armature doesn't hit on the coil and that the coil leads and retaining springs or bracket (see Fig. 32 or Fig. 34) haven't been left in the way so that armature hits them when it closes.

9. The machined faces of the armature and magnet frame must be free of all foreign material including grease.

10. Pole shaders. These contactors will have either of two types of pole shaders with different methods for retaining them.

(a) Flat pole shaders (see Fig. 32 or 34)

The pole shaders must be assembled tightly to the magnet frame so that the pole-shader retaining ears and the pole shader itself are appreciably below the machined faces making contact with the armature. Bend the pole-shader retaining ears down over the pole shader to hold it tightly and keep it from rattling.

(b) Curved pole shaders (see Fig. 31)

Curved pole shaders must be snapped into slots A and B on magnet frames without retaining ears as shown in Fig. 31. Do not use any tool that will nick or change the shape of the pole shader. It must not be squeezed to tighten it in the magnet slots. In its final position, it must not have enough freedom to rise above the machined faces of the magnet.

[www.ElectricalPartManuals.com](http://www.ElectricalPartManuals.com)

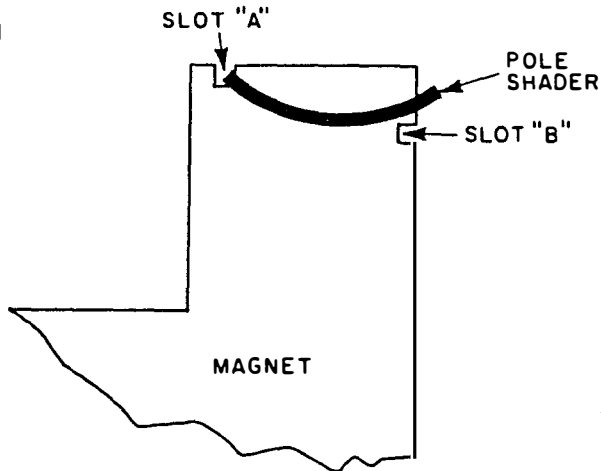

Fig. 31. Curved pole shader

## DC MAGNET ASSEMBLY

1. Top surfaces of armature and stationary-magnet frame (see Fig. 29) must be aligned within 1/16 inch. Alignment is not so important as with ac magnets as noise problems are not encountered. Armature must be approximately centered laterally over stationary-magnet frame.
2. Contact faces of magnet can be made to seat flush against each other in same manner as for ac magnets. Alignment is again not so important for reasons mentioned in Item 1 above.
3. Armature in picked-up position must have a minimum of 1/64-inch spacing between it and armature bracket (see Fig. 29). Fulcrum plate must be always assembled with its emboss toward its armature bracket per Fig. 29.
4. The armature bracket must be assembled to its shaft-supporting bracket in such a manner that the armature has a vertical end play in its armature support of 1/32-inch minimum (see Fig. 29). Armature width is made so that a side play of 1/32-inch exists. This freedom of the armature in all directions is necessary to allow it to seat properly against the magnet frame.
5. Check also to be sure armature doesn't hit on coil, and that coil leads and retaining springs or bracket (see Fig. 32 or 34) haven't been left in the way so that armature hits them when it closes.
6. Magnet coils can be replaced per "Replacing Magnet Coils" section of these instructions. Magnets must be replaced when air gap between their center legs reaches 1/64-inch to insure proper drop out. This air gap with new magnets is 1/32-inch.

## REPLACING MAGNET COILS

To replace an operating coil, the following steps are recommended:

1. Loosen the backstop support bolts and rotate the backstop in the position (see Fig. 33 and 35).
2. Disconnect coil leads at the coil (see Fig. 32 and 34).

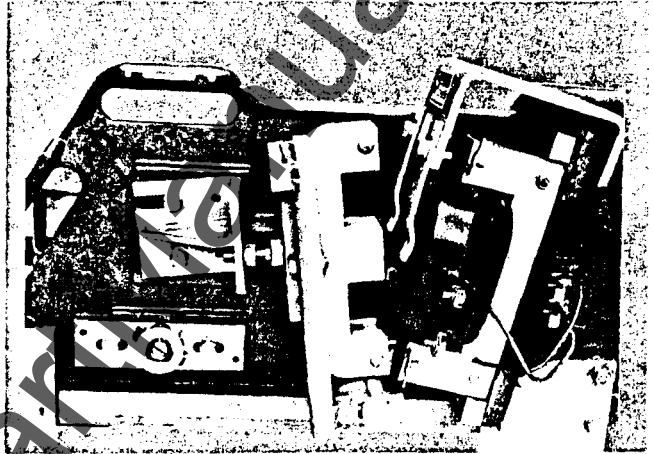

Fig. 32. Magnet structure with old style coil-retaining assembly

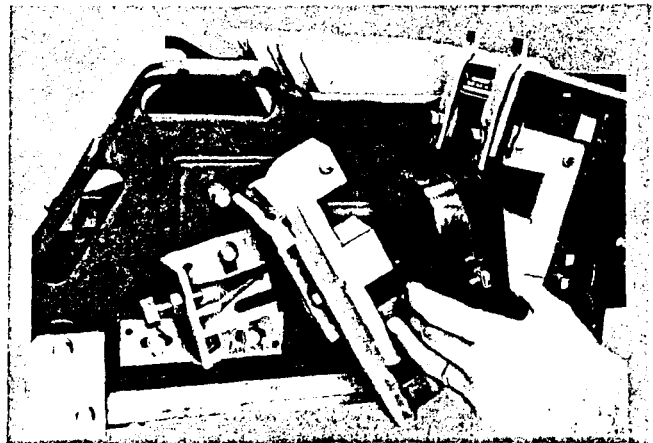

Fig. 33. Backstop rotated to permit removal of coil

3. For contactors that have a coil retainer as shown in Fig. 32, loosen bolts that secure the two coil retaining springs and rotate the springs 180 degrees, as shown in Fig. 33, and remove the coil.

[www.ElectricalPartManuals.com](http://www.ElectricalPartManuals.com)

3a. For contactors having a coil retainer as shown in Fig. 34, remove hardware that bolts the coil retainer to its support. Remove retainer as shown in Fig. 35 to allow removal of the coil.

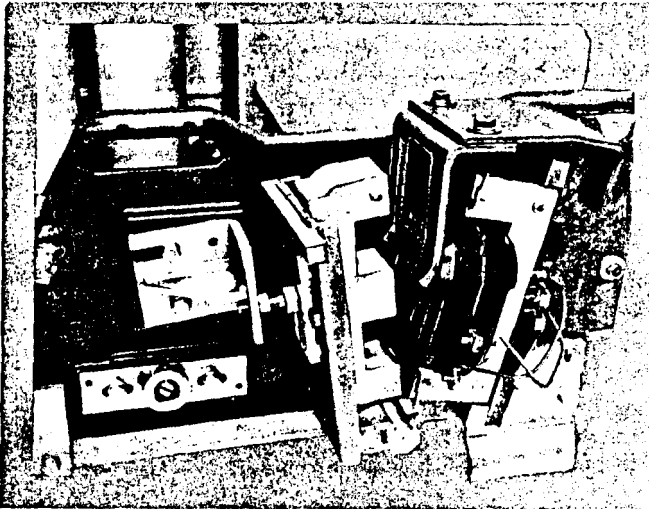

Fig. 34. Magnet structure with new style coil retainer

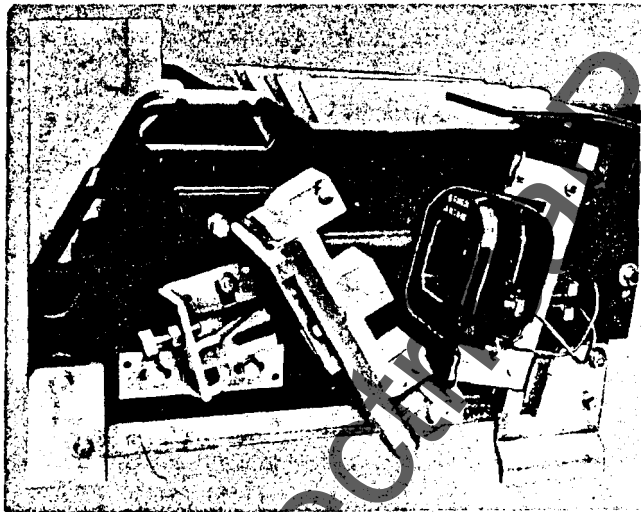

Fig. 35. New style coil retainer removed to allow removal of coil

### REPLACING SIDE FRAMES

When necessary to replace a side frame, it is recommended that the following steps be followed:

1. Rotate disconnect assembly to position for one-high contactor as shown in Fig. 26, so that the assembly is supported by the interphase barriers. Place blocks under the blowout base to support it when the side has been removed.

2. If replacing the side to which the magnet assembly is mounted, remove stationary magnet from side and remove movable-armature assembly from the shaft.

3. The side can now be removed by loosening hardware that mounts the side to the blowout base, and mounts the wheel brackets, stub shaft assembly and the bearing block to the side.

4. Replace the side, then position the side so that the proper tip gap, wipe and lineup as described in section "When to Replace Contacts."

5. Replace stub shaft assembly, then position disconnect assembly to obtain dimensions locating operating shaft, power disconnects and intermediate stabs per Fig. 11 or 12 (see Fig. 7 for identification and location of parts).

6. After tightening all bolts, drill and pin side to the blowout base. Do not use pilot hole in side as it may run into existing hole in the blowout base. Also, drill and pin the stub shaft assembly to the new side.

7. When mounting armature assembly to shaft, care should be taken to use special high-strength bolts that have been provided.

### REPLACING MAIN SHAFT ASSEMBLY

When necessary to replace shaft assembly, it is recommended that the following steps be followed:

1. Remove armature assembly from shaft. Then remove movable-tip assemblies from the shaft by removing the 1/4 - 20 bolts that secure the small shaft, on which the movable-tip support rotates, to the main shaft.

If new movable tip assemblies are part of the replacement shaft, then it will only be necessary to remove the shunts from the old shaft assembly.

2. Remove left side (side opposite magnet) as described in section "Replacing Side Frames."

3. Remove collars from old shaft and place on new shaft.

4. Replace shaft and side frame. Then replace movable-tip supports, if necessary, and armature assembly.

5. Make adjustments as described in "Replacing Side Frames."

6. Adjust collars, to maintain a shaft end play of 0.030 inch to 0.050 inch. Set-screws in the collar should be tightened with sufficient torque to insure that screws will not loosen. This can be accomplished by twisting the wrench 90 degrees.

[www.ElectricalPartManuals.com](http://www.ElectricalPartManuals.com)

## GEH-3102C, High-voltage Ac Contactors

### REPLACING BLOWOUT COIL BASE

1. When replacing the base of a one-high contactor, support the overhanging portion of the disconnect assembly, as removing the weight of the base will cause the contactor to tip over.

2. Remove the stationary-magnet assembly to allow access to mounting hardware.

3. Remove the blowout-coil assemblies, arc-horn stabs and stationary tips by removing screws "A" and "B" as shown in Fig. 36, and bolts located below the base, that secure the blowout-coil stab to the base. Care should be taken to observe how parts are assembled so that they can be re-assembled properly on the new base.

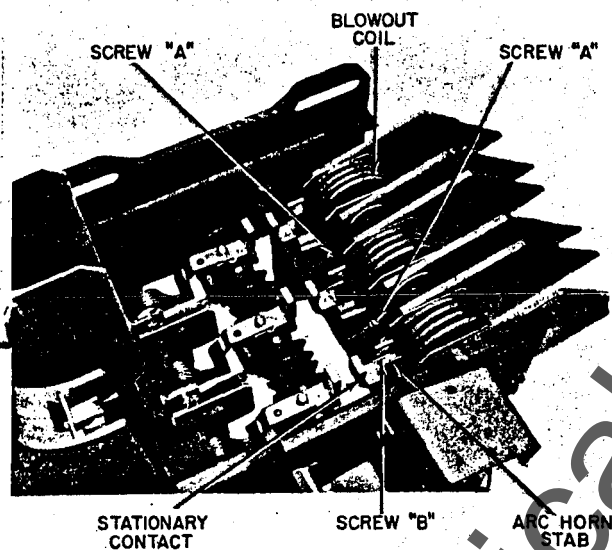

Fig. 36. Blowout base and main shaft assembly

4. Scribe the outside of the base on the inside of the side frames. This will help to position new base.

5. Remove the hardware mounting the sides to the base and pry sides away from the base to disengage roll pins. Remove pins that remain in the side frames.

6. Assemble new base to the side frames. Line up base with the scribe marks on the sides. Snug up hardware.

7. Assemble the blowout-coil assemblies, arc-horn stabs and the stationary tips to the base. When replacing the hardware that secures the blowout stab to the base, assemble the stab against the base (see Fig. 14). The special regular nut must be against the slot in the base.

8. Adjust base to obtain tip gap, wipe, and lineup as given in section "When to Replace Contacts."

9. Check to insure that the blowout-coil stabs properly engage the finger assembly in the enclosure.

10. Drill and pin sides to the base after all adjustments are made.

11. Check to insure the gap across the arc-horn stab is 0.56 inch to 0.70 inch to insure electrical connection to the arc horn.

12. Rotate the disconnect assembly to insure that the arc chutes will have a clearance of 1/8 inch to 3/16 inch between the chute and its corresponding pole pieces. Bend the pole pieces to obtain this dimension. Also, the interphase barrier must miss the blowout and core hardware by a minimum of 1/8 inch. Also check the dimensions locating the operating shaft, power disconnects and intermediate stabs per Fig. 11 or 12.

### REPLACING FUSE BASE

Should it be necessary to replace the fuse base, it is recommended that the following steps be followed. If replacing fuse base on a three-high contactor, raise the contactor approximately one foot. Keep the area below the fuse base clear.

1. Remove the shunt terminal from the movable-tip assembly and push shunts below shaft assembly.

2. Rotate the disconnect assembly to its operating position.

3. Remove the lower power fuse clips and mounting bracket "A", as shown in Fig. 25, from all poles.

4. Remove the stub shaft assembly from both side frames being careful not to damage holes in side frame that contain the roll pins.

5. Lower the fuse base to the floor or below the centerline of the shaft so that the interphase barriers can be removed.

6. Lift fuse base out from between side frames.

7. Bolt mounting block, containing tapped holes for lower fuse clips, to new base. Mount connection strap, shunt and intermediate stab assembly to new base. Tighten hardware finger tight.

8. Position new base assembly below centerline of shaft and between side frames and replace interphase barriers.

9. Raise fuse base to engage the three arc-chute assemblies and interphase barriers. Maintain in position by replacing the stub shaft assembly on side frames.

[www.ElectricalPartManuals.com](http://www.ElectricalPartManuals.com)

10. Replace lower fuse clips and bracket. Tighten hardware.

11. Rotate disconnect assembly to service position and tighten hardware on underside. Care should be taken to position silver plated stab against its steel back support.

12. Check locating dimensions for intermediate stabs, operating shaft and power disconnect finger per Fig. 11 or 12.

13. Drill and pin stub shaft assembly. It may be possible to pin in existing holes in side frames.

### POWER-STAB FINGERS

Power-stab fingers must be maintained in location per "Power and Control Disconnects" section (page 9) instructions so that the proper power connections will be made at all times. Only very rough handling would cause these fingers to change in location. They should be free to rock 1/8 inch in each direction.

A pressure of 45 to 55 pounds on a stationary or male stab must be maintained to make proper connections. These pressures were properly set at the factory and should not change unless the assemblies have loosened through rough handling or the power finger springs have been damaged.

These pressures can be set on the power fingers with the following procedure (see Fig. 37).

1. Select, for a finger spacer, a piece of metal that is  $1/2 \pm 0.002$ -inch thick. Cold-rolled steel of this thickness would be very satisfactory as its tolerance is within this range.
2. With the adjusting nut located for weak spring pressure, insert the finger spacer between the pairs of fingers.
3. Tighten the adjusting nut until there is a very slight drag on the finger spacer when trying to pull it out of engagement.
4. Record the position of the nut by placing pencil marks on the nut and finger guide opposite each other. Set proper pressure by turning the nut through exactly one full turn in the direction to increase the spring pressure. If the finger assembly uses a bellville washer-type spring, turn the nut through  $1/2$  turns. The nut will remain in position as it is a self-locking nut.

The power fingers and control-disconnect fingers do not need lubrication; but grease (Nebula\* No. 1 of Exxon or equal) can be added to the power-finger surfaces mating

with the stabs, if desired. All fingers have been tested in contaminants such as cement, metal, dust and paper-mill atmospheres and have been found to function satisfactorily without grease. If foreign matter collects on the stabs or power fingers (condition is worse with grease as it holds dust, etc.), it must be removed by blowing or brushing as this matter will interfere with the ease of operation of the disconnect assembly and stabbing in general.

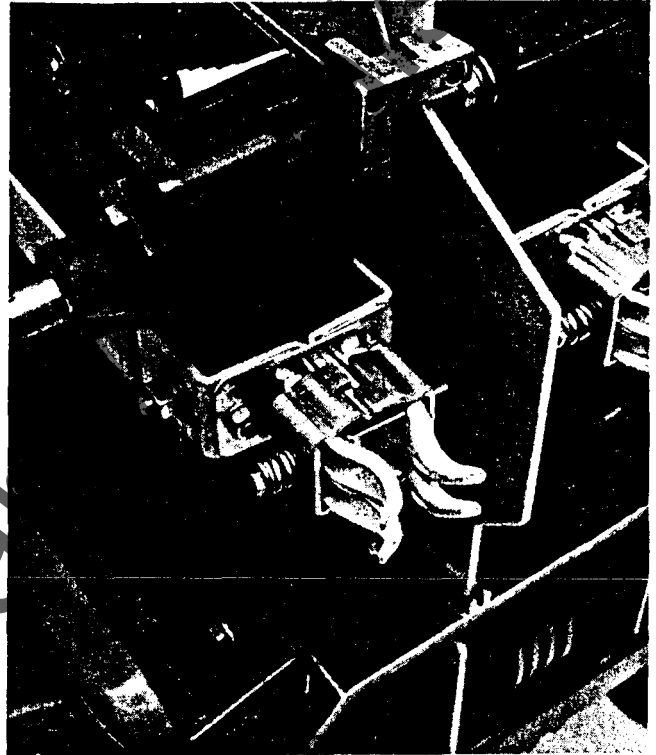

Fig. 37. Power-stab fingers

### HARDWARE

Special, high-strength bolts and washers are used in various areas to mount or bolt parts together. This special hardware can be easily recognized because it does not have a zinc-chromate finish. When replacing parts, care should be taken to reuse this hardware. Do not replace this hardware with standard hardware.

### TIGHTENING TORQUES

When making bolted assemblies, the following consideration should be generally followed. The tightening torques are determined by the size of hardware used.

1. Metal-to-Metal – Apply standard tightening torque as listed:

Thread Size	Torque (In.-Lb)
8-32	14- 20
10-32	20- 30
1/4-20	40- 60
5/16-18	168- 228
3/8-16	240-360

\*Trademark of Exxon Company USA.

[www.ElectricalPartManuals.com](http://www.ElectricalPartManuals.com)

## GEH-3102C, High-voltage Ac Contactors

2. Metal-to-Insert Molded in Compound Part – Apply approximately 2/3 of standard tightening torque.

3. Compound-to-Insert Molded in Compound Part – Apply approximately 1/2 of standard tightening torque.

4. Compound-to-Compound – Apply approximately 1/2 of standard tightening torque.

### ELECTRICAL INTERLOCKS IC2814E250, E251, E550, E551 and E451 MODELS

The electrical interlock consists of three contact units, each with contacts for two (2) circuits. Each contact unit as supplied will contain one normally open and one normally closed circuit. These contact units (see Fig. 5) are operated by a sensor bar that engages the activator bar on the armature bracket.

#### ADJUSTMENTS

Adjustment of these interlocks is critical to the operation of the contactor. The following adjustments should be maintained:

1. With the interlock assembly mounted on the contactor and the contactor units in the de-energized position, adjust the guide bar and the sensor bar, relative to the activator pin on armature support, to dimensions shown in Fig. 38.

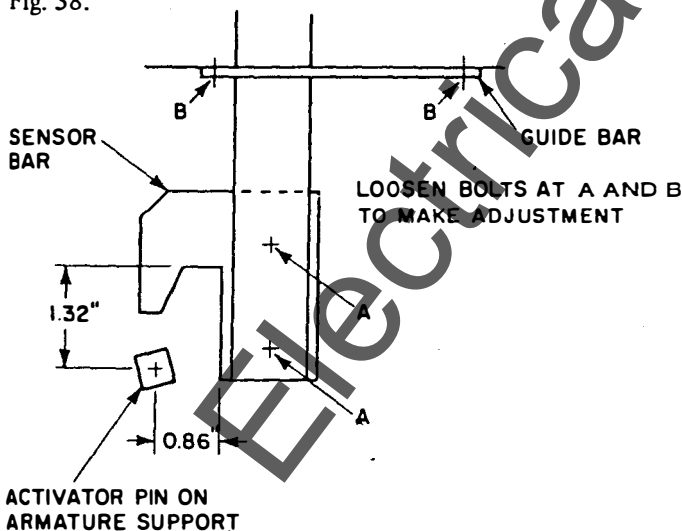

Fig. 38. Location of activator pin to sensor bar with contactor de-energized

2. The engagement of activator pin on armature support with sensor bar should be such that an overlap of 0.25 inch to 0.42 inch exists. If necessary, shims may be used to obtain this dimension (see Fig. 39).

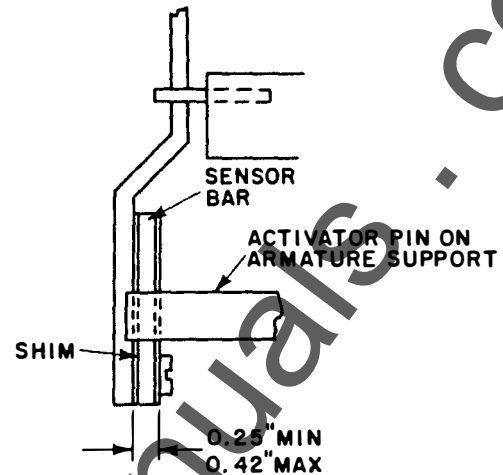

Fig. 39. Overlap of activator pin and sensor bar

3. To assure "Free-closing" of armature in connection with sensor bar, a minimum of 0.12 inch of additional travel of sensor bar should exist when armature is fully picked up (see Fig. 40).

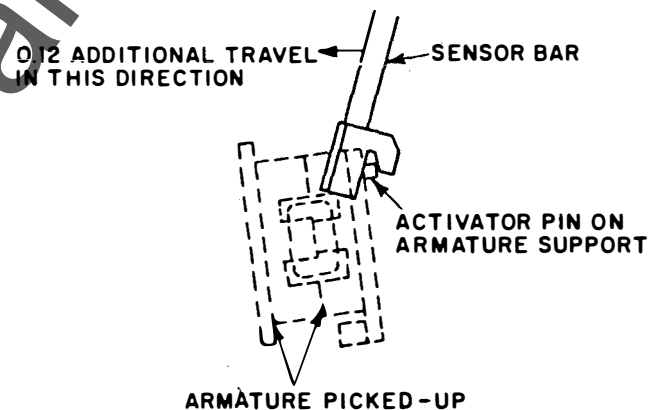

Fig. 40. Activator pin engaged in sensor bar with contactor energized

4. When contactor drops out, check to insure that the spring-loaded sensor bar returns to its fully open position.

5. After sensor bar has been properly located, adjust the gap between the interlock plungers and the depressor brackets as shown in Fig. 41. Slots are provided in the depressor bars to permit adjustment.

6. With the contactor armature in its fully closed or energized position, check all interlocks to see that the following tip gap and wiper are maintained:

- (a) Normally closed tip gap—5/64-inch minimum
- (b) Normally open tip wiper—3/64-inch minimum

[www.ElectricalPartManuals.com](http://www.ElectricalPartManuals.com)

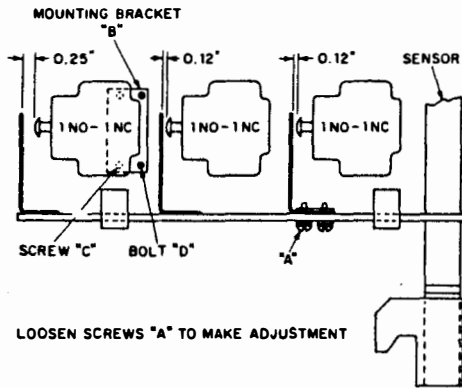

Fig. 41. Adjustments of interlock assembly

Interlock contacts should be applied in circuits consistent with the make, break, and interruption ratings of Table 3. Contacts applied outside of these ratings will have reduced life and may not operate satisfactorily.

TABLE 3 INTERLOCK RATINGS (In Amperes)

Number of Contacts	Carry	Make	Interrupt							
			Dc Inductive*			Ac†				
			125V	250V	600V	110V	220V	440V	600V	
One Set	10	60	1.8	0.5	0.2	6	3	1.5	1.2	
Two Sets in Series	10	60	4.0	1.2	0.35					

\* Non-inductive dc interrupting rating is 1.5 times inductive.

† Capable of interrupting inrush current of 60 amperes at 110 volts, 30 amperes at 220 volts, 15 amperes at 440 volts, and 12 amperes at 600 volts a limited number of times.

## MAINTENANCE

The locating of the electrical interlocks with reference to the assembly which operates them must be maintained in accordance with the introductory section concerning electrical interlocks. If the hardware has not loosened because of abnormal handling, these adjustments will be maintained.

### Replacing or Rearranging Movable and Stationary Contacts

This interlock has been designed so that the movable or stationary contacts can be replaced or rearranged to change an individual assembly to give a different number of normally open or closed contacts. When these operations are performed, the parts must be reassembled in accordance with Fig. 42, 43 and 44, the previous instructions and the following requirements.

**NOTE:** If the contacts in an electrical-interlock housing are changed from normally open to normally closed or vice versa, the contactor

involved will not agree with its nameplate and will not be identical with another contactor with the same nameplate stamping

1. The spring ends must not protrude into the holes (A), slots (B), or keys (C), which serve as guides for the operating rod (see Fig. 42).

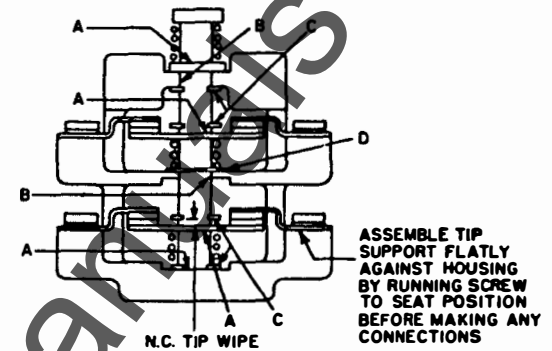

Fig. 42. Interlock block with normally closed contacts in unoperated position

2. The stationary-contact assemblies must be driven down over the molded-brass inserts in the molded housings in such a manner that they lay flat against the housing.

3. Contact blocks with two normally closed circuits require a spring spacer (D) as shown in Fig. 42 to assure that the center spring is properly in place.

Because of the circuit rearrangement feature, a spring spacer is supplied with all two-circuit contact blocks, as shown in Fig. 43 and 44.

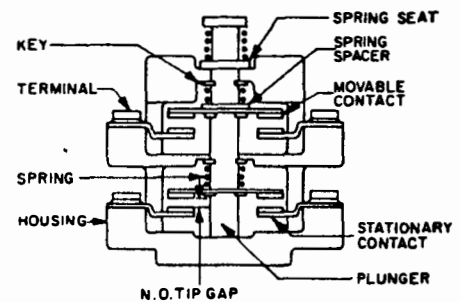

Fig. 43. Interlock block with normally open contacts in unoperated position

4. When circuits are rearranged to obtain one normally open and one normally closed circuit, the normally closed circuit must be located at the bottom as shown in Fig. 42.

5. On the completed interlock, the operating rod must operate freely without excessive winding or scraping which would indicate improper assembly.

6. The contacts of a movable-contact assembly must also make with their corresponding stationary contacts at

[www.ElectricalPartManuals.com](http://www.ElectricalPartManuals.com)

## GEH-3102C, High-voltage Ac Contactors

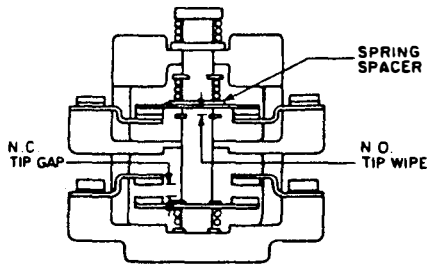

Fig. 44. Interlock block with one set of normally open contacts and one set of normally closed contacts in operated position

the same time within 1/64 inch. Bend the stationary-contact support up or down with the fingers to obtain this requirement.

### When To Replace and Service Electrical Interlocks

Contact assemblies or preferably the whole interlock assembly (one assembly includes contacts for two circuits) should be replaced when the following conditions exist:

1. The contacts are badly pitted to the point where the bottoms of the pits are close to touching the steel backing of the silver facings of the contacts. The top of the steel backing is obvious from looking at the side of the contact. The bad build-ups on the one contact opposite the pits of the mating contact can be removed and thus extend the life of the contacts through forcing the contacts to make on other areas.

**NOTE:** Tarnish on the silver facings does not have to be removed, as with power the tarnish breaks down into products which are conducting.

2. If the contacts are worn so that they are thrown very badly out of alignment, the contact assemblies should be replaced to reduce friction between the movable parts of the interlock.

3. When the wipe is reduced to one half of the minimum values shown in the general section of "Electrical Interlocks," the contact assemblies should be replaced to obtain proper pressures to allow the interlock to operate satisfactorily. The wipe is the compression in inches of movable-contact spring between the energized and de-energized positions of contactor (see Fig. 42 and 44).

### Replacing Complete Electrical Interlock Assembly

An electrical interlock can be replaced by following the steps outlined below (see Fig. 41).

1. Tag the wires and then disassemble the wires of the interlock to be replaced.

2. Each interlock, plus its mounting bracket "B," can then be removed through loosening bolts "D."

3. Each interlock assembly can then be removed from its bracket "B" by removing self-tapping screws "C."

4. The interlock can be replaced by following the reverse of the steps outlined above.

5. Interlocks should be adjusted in accordance with instructions per the general section of "Electrical Interlocks."

## MODELS IC2814E411 THRU IC2814E451

### INTRODUCTION

These contactors have a 700-ampere open rating for use in 600- to 5000-volt applications (see Fig. 45).

These contactors are applied in substantially the same enclosures as the IC2814E220 family of contactors. Slight extensions on doors are required to accommodate the larger fuses. The contactor fuse-grounding fingers of the enclosure must be raised one inch. Male stabs in the enclosure must have silver inlays (1/32-inch thick) brazed to each side for the contactor stab fingers to slide on.

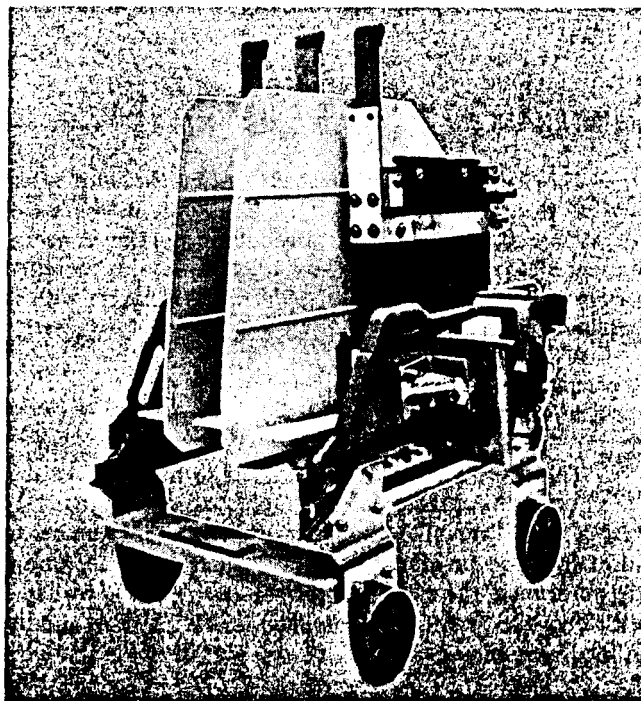

Fig. 45. 700-ampere contactor without fuses

[www.ElectricalPartManuals.com](http://www.ElectricalPartManuals.com)

**DESCRIPTION**

The current-carrying portions of this contactor are different from the 200- and 400-ampere family of contactors and are not interchangeable. The parts involved are as follows:

1. The blowout coils consist of a single-turn primary coil which is in series with a six-turn auxiliary coil during interruption only (see Fig. 46).

2. Special arc horns are used for the increased interruption rating. These are modified to clear the insulated-bolt assembly at the stationary tip. Flathead screws are used to attach the copper block to the long arc horn.

3. The contact tips are 1 3/4-inch wide and have beveled upper corners (see Fig. 6A).

4. The shunts are thicker and are formed differently.

5. Male stabs on the blowout coil and on the bottom of the fuse assembly have silver inlays brazed on each side for the enclosure stab fingers to slide on.

6. Bus assemblies on each side of the upper chute are brazed together and have silver overlays brazed on the stab end for stab fingers to rest on.

7. There are special bus supports for the top and bottom of each fuse.

8. These contactors will only use dc operating magnets.

9. Movable-contact tip springs (see Table 2).

10. The interphase barriers are thicker and larger in size and are not interchangeable with those of the 200- and 400-ampere family of contactors. They are assembled in the same manner.

**INSTALLATION**

These contactors can be installed using the same procedure as the 200- and 400-ampere family of contactors. It should be noted that these contactors will use only bolted fuses.

**MAINTENANCE**

The following procedure must be followed in maintenance inspections:

1. General inspection can be accomplished by rotating the disconnect assembly until the interphase barriers rest against the pan between the wheel supports. It can then be held in position while making inspections.

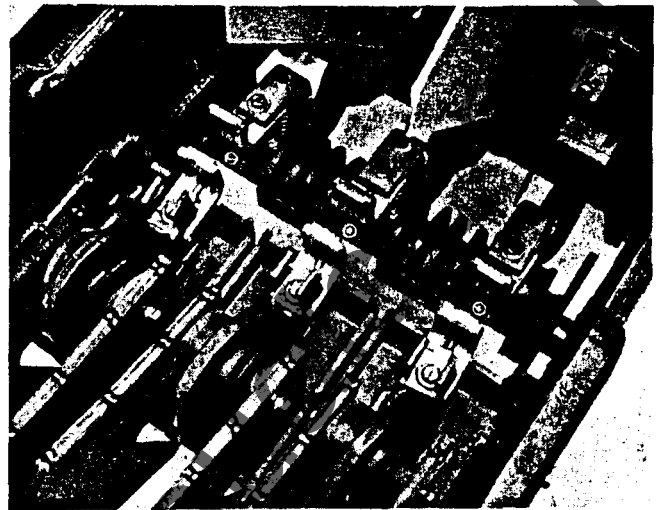

Fig. 46. Blowout assembly of 700-ampere contactor

2. If parts are to be changed, block the disconnect assembly in place before replacing parts.

3. As stated previously, the blowout-coil assembly consists of two coils, therefore, when changing the stationary-contact tips it is most important to make sure that the blowout-coil connections are correct. The following procedure should be noted:

- (a) A special bolt assembly and insulation pads are utilized to insulate auxiliary coil so that it is in the circuit only during interruption.
- (b) The auxiliary-coil terminals and insulation must be assembled as shown in Fig. 47.
- (c) The lower terminal of the auxiliary coil must be against the stationary tip.

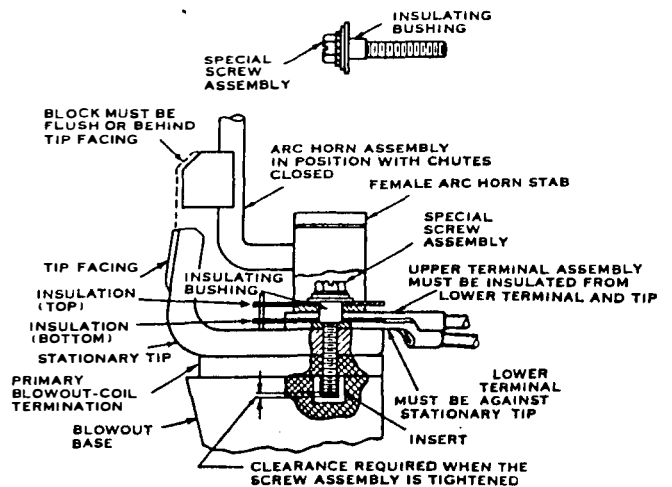

Fig. 47. Blowout-coil connection assembly

[www.ElectricalPartManuals.com](http://www.ElectricalPartManuals.com)

[www.ElectricalPartManuals.com](http://www.ElectricalPartManuals.com)

[www.ElectricalPartManuals.com](http://www.ElectricalPartManuals.com)