

**Instructions**

Utilization Voltage—  
2300, 4000 & 4600 Vac  
Distribution Voltage—  
2400, 4160 & 4800 Vac



# IC7160 Limitamp<sup>®</sup>

## Controllers with Draw-out Air-break Contactor

**CAUTION:** Before installing in a nuclear application, determine that the product is intended for such use.

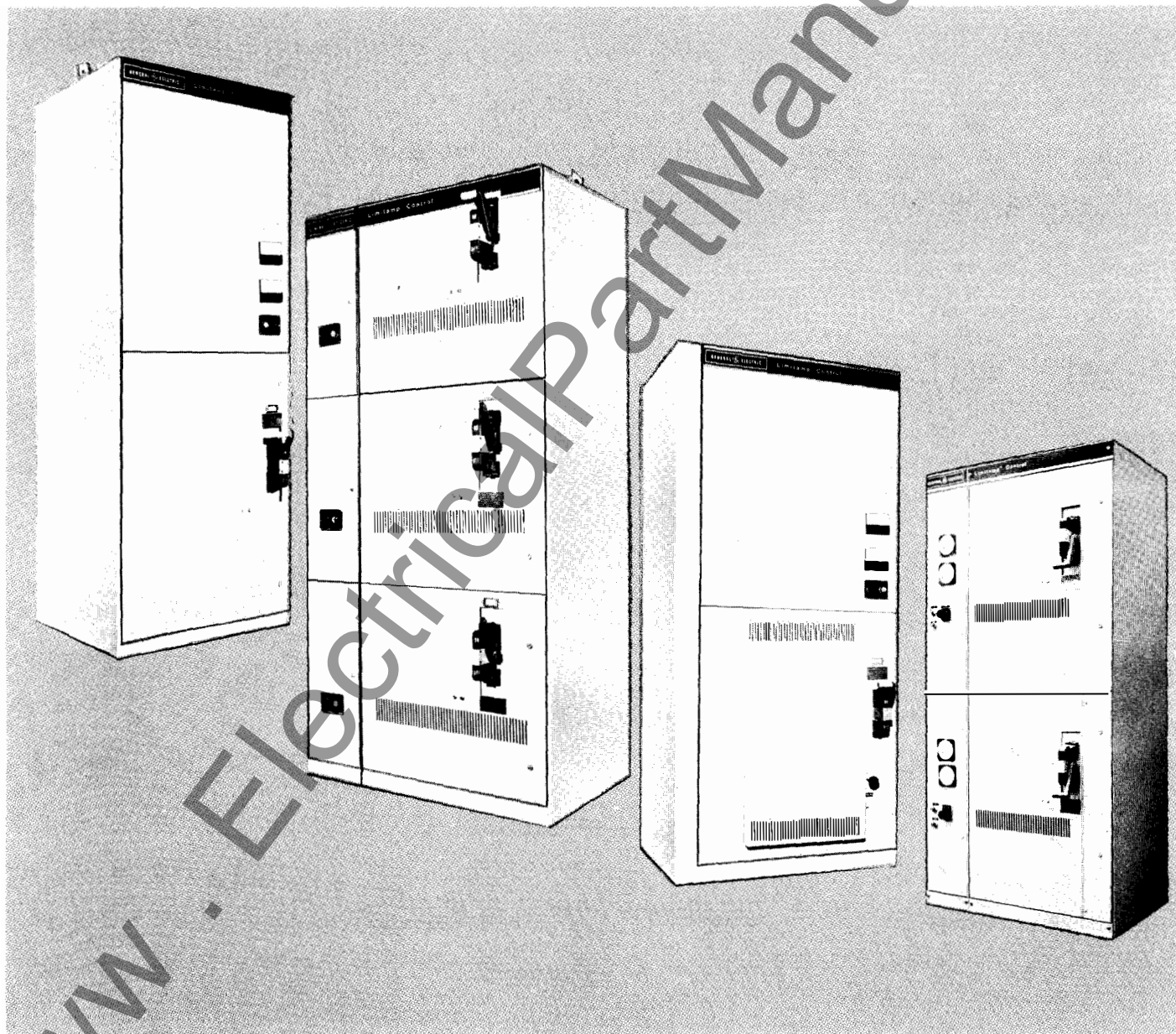

## CONTENTS

	Page
INTRODUCTION . . . . .	3
DESCRIPTION . . . . .	4
Equipment Identification – IC Number Designation . . . . .	4
General . . . . .	4
Ratings . . . . .	5
High-voltage Contactors . . . . .	5
Manual Disconnect or Isolating Mechanism . . . . .	7
Mechanical Interlocking . . . . .	7
Auxiliary Enclosures . . . . .	8
Dimensions . . . . .	8
Power Fuses . . . . .	8
Starting Autotransformers and Reactors . . . . .	8
INSTALLATION . . . . .	9
General . . . . .	9
Receiving . . . . .	9
Handling . . . . .	9
Placement of Enclosure . . . . .	11
Disassembly – One-high Designs . . . . .	11
Disassembly – Two-high Designs . . . . .	14
Disassembly – Three-high Designs . . . . .	17
Grounding . . . . .	20
Incoming Power Connections . . . . .	20
Motor Connections . . . . .	23
Power Cable Termination . . . . .	25
Control Connections . . . . .	30
Reassembly – One-, Two- and Three-high Designs . . . . .	31
Mechanical Operation Check . . . . .	32
Assembly of Outdoor Enclosures . . . . .	33
OPERATION . . . . .	33
General . . . . .	33
Test-power Circuit . . . . .	33
Preparation of Controller for Operation . . . . .	34
Normal Operation . . . . .	34
Door Opening Procedure . . . . .	34
INSPECTION, MAINTENANCE, AND SERVICING . . . . .	36
Drawout Contactor . . . . .	36
Isolating Mechanism and Mechanical Interlock . . . . .	36
Adjustment of Electrical Interlocks . . . . .	42
Power Stabs . . . . .	43
Preventive Maintenance Guide . . . . .	43
RENEWAL PARTS . . . . .	44
APPENDIX (Outline Drawings) . . . . .	46

## PUBLICATION REFERENCES

Renewal Parts for Contactor . . . . .	GEF-4337
Instructions for Contactor . . . . .	GEH-3102
Synchronous Motor Control . . . . .	GEH-3133
Application Data . . . . .	GET-3140

*These instructions do not purport to cover all details or variations in equipment nor to provide for every possible contingency to be met in connection with installation, operation or maintenance. Should further information be desired or should particular problems arise which are not covered sufficiently for the purchaser's purposes, the matter should be referred to the General Electric Company.*

# IC7160 LIMITAMP<sup>®</sup> CONTROLLERS

*Before any adjustments, servicing, parts replacement or any other act is performed requiring physical contact with the electrical working components or wiring of this equipment, the POWER SUPPLY MUST BE DISCONNECTED.*

## INTRODUCTION

Limitamp controllers are designed to comply with NEMA Part ICS2-324, "A-c General-Purpose High-Voltage Class E Controllers", and may be described as metal-enclosed high-interrupting capacity, drawout, magnetic-contactor-type starter equipments with manual isolation. Individual starters and controllers are designed for specific applications; the components and functions being dictated by the Purchaser specifications and needs. Controllers may be fused or unfused.

The essential control functions for all types of a-c motors consist of starting, stopping, and overload protection. Limitamp controllers also include short-circuit protection, but other functions are provided in each controller as they are applicable to the type of motor being controlled (such as synchronous and wound-rotor motors). Also, special

functions are provided in great variety as may be required for particular applications.

These instructions are prepared as a guide to handling, installation, operation, and maintenance of all types of Limitamp controllers. This includes the 34-inch-wide one-high, 42-inch-wide one-high, and 44-inch-wide two- and three-high designs. Fig. 1 shows the 34-inch-wide one-high controller, Fig. 2 shows the 44-inch-wide two-high controller, Fig. 3 shows the 44-inch-wide three-high controller, and Fig. 4 shows the 42-inch-wide one-high controller.

The intent of these instructions is to give the Purchaser the necessary general information to identify his controller as to type and function, to describe suggested methods of installation, and to demonstrate some techniques of operation and maintenance. Separate instructions covering components are not included in this publication, but are available upon request. The Purchaser should interpret these instructions for applicability to his particular controller by referring to the nameplate data on the controller and to the electrical diagrams supplied with the controller.

If the controller is for a synchronous motor, these instructions should be used with GEH-3133.

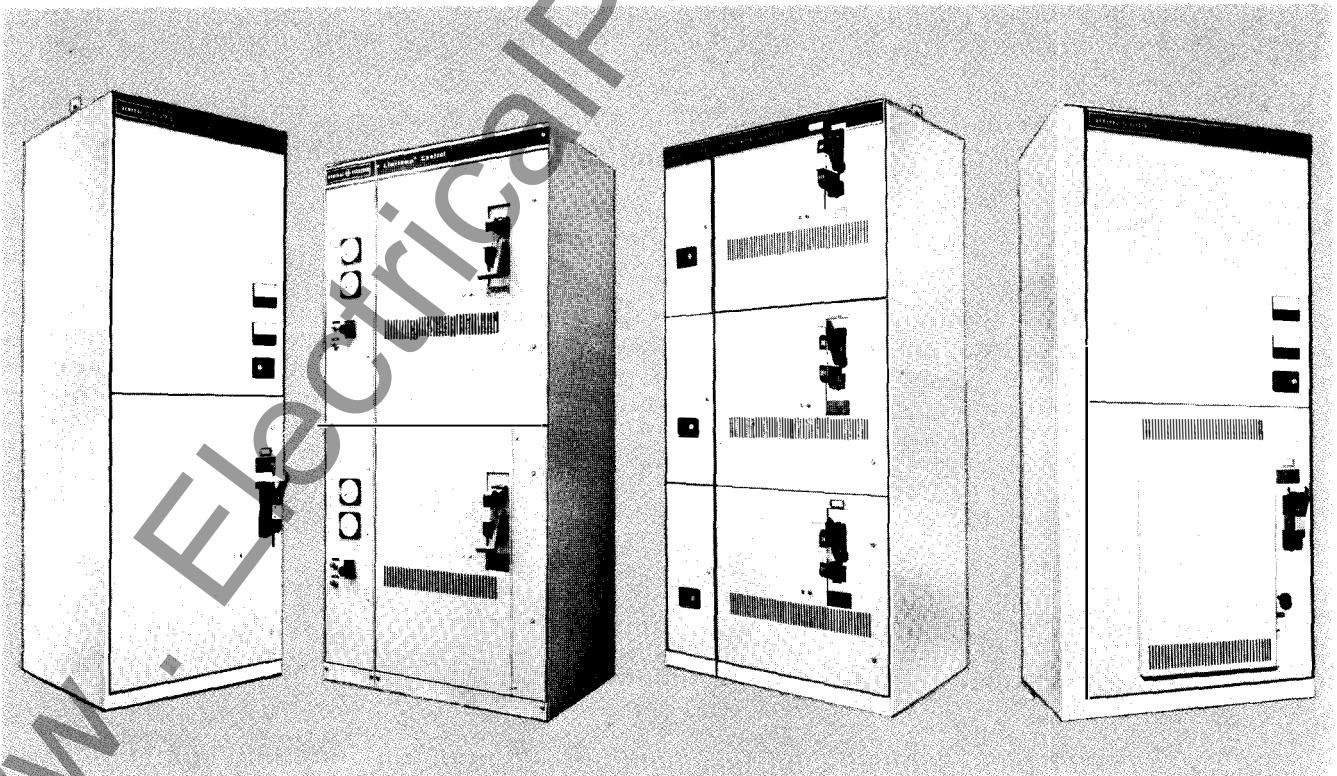

Fig. 1. 34-inch-wide one-high controller.

Fig. 2. 44-inch-wide two-high controller.

Fig. 3. 44-inch-wide three-high controller.

Fig. 4. 42-inch-wide one-high controller.

**DESCRIPTION**

**EQUIPMENT IDENTIFICATION—IC NUMBER DESIGNATION**

Basic type designation for all Limitamp air-break equipment is IC7160, with significant alphanumeric suffixes used to define rating, function, and model design vintage.

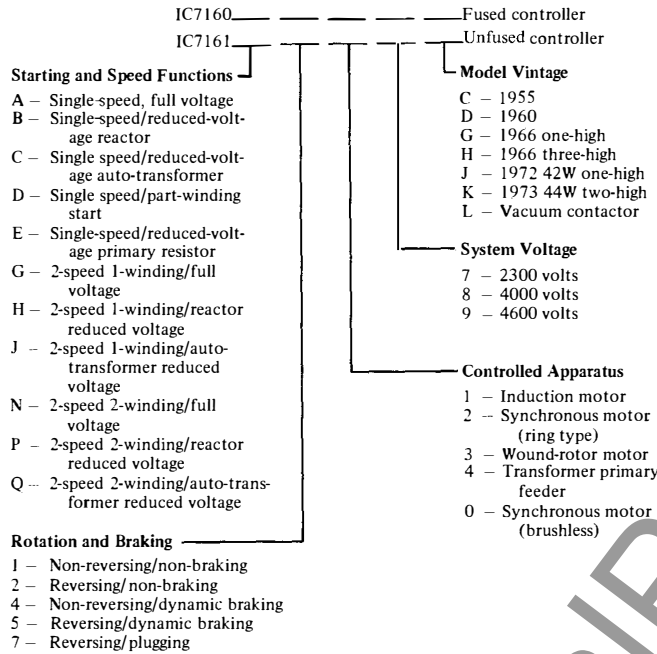

**GENERAL**

The basic Limitamp controller is a front-connected assembly of components and conductors for motor starting, arranged for convenient access, in an enclosure which allows space and facilities for cable termination, plus safety interlocking of doors and isolator to prevent inadvertent entrance to high-voltage parts. No back access is required. This equipment is rated 5000 volts, and may be used on voltages between 2300 and 5000 volts. Installation, operation, and service should be performed only by experienced personnel trained in this class of equipment.

In general, the unit enclosures are divided into high-voltage and low-voltage compartments, each with its own separate door and with interior barriers between the two. See Fig. 5, 6 and 7. In order to open the high-voltage compartment door, the power must be disconnected by a sequence of manual operations which requires de-energizing the high-voltage contactor, operating the isolating switch handle, and unlatching the door. Low-voltage doors may be entered without disconnecting the power, but should be done with extreme care and caution.

The upper compartment of one-high controllers may contain a low-voltage panel, hinged on the left side, which acts as a barrier to the high-voltage control power transformer mounted on the upper rear cover.

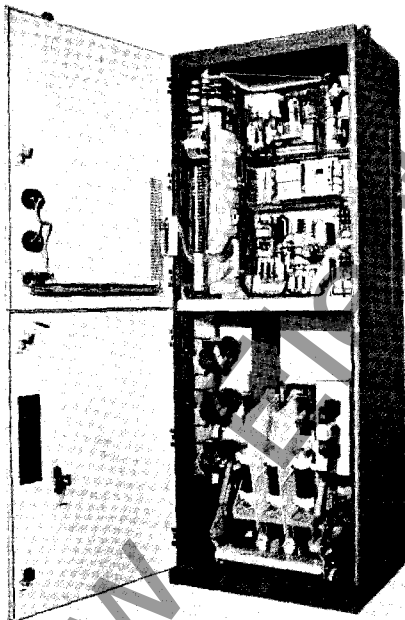

Fig. 5. One-high design, showing separation of low and high-voltage compartments for a synchronous-motor controller.

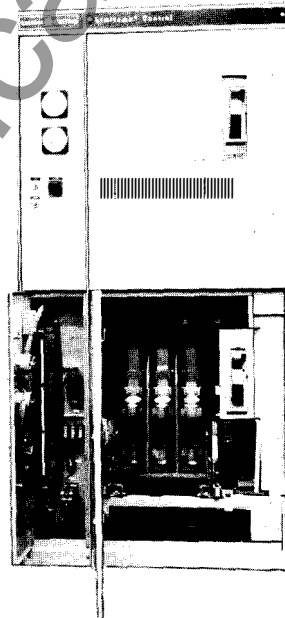

Fig. 6. Two-high design, showing high-voltage compartment.

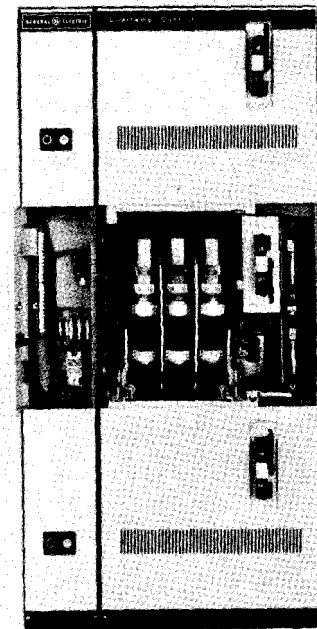

Fig. 7. Three-high design for compartment separation.



Fig. 8. Limitamp isolator handle padlocking provisions.

**RATINGS**

Refer to the panel data nameplate on front of the enclosure for detailed ratings applicable to a particular controller. Equipment basic ratings equal or exceed NEMA ICS #2-324, and are summarized below:

**Horsepower, Current, and Voltage Ratings**

Continuous Current Amperes	2200 - 2400 Volts			4000 - 4800 Volts		
	Induction Motors	Synchronous Motors		Induction Motors	Synchronous Motors	
		0.8 PF	1.0 PF		0.8 PF	1.0 PF
360 max	1500	1500	1750	2500	2500	3000
630	2500	2500	2750	4500	4500	5000

**Interrupting Ratings**

Maximum Volts	Maximum Continuous Amperes	Three-phase Symmetrical System MVA	
		Class E1 Unfused	Class E2 Fused
2500	360	50	200
4800	360	50	400
2500	630	80	250
4800	630	80	500

**Basic Impulse Level**

60-kv crest (design rating). Excludes control transformer and starting reactors or autotransformers.

**Dielectric Test**

2-1/4 x nameplate voltage plus 2000 volts.

**HIGH-VOLTAGE CONTACTORS**

The air-break high-voltage contactors used in Limitamp controllers are all of similar design. Those of ampere rating 360 and below have the advantage of being usable interchangeably in the one-,

two-, and three-high enclosures, with minor parts differences. Refer to GEH-3102. Contactors used in the two- or three-high enclosures contain a positioning handle that is not on the one-high contactor. One-high contactors contain wheels and bottom stabs that are not on the two- or three-high contactors. Catalog numbers of the parts involved are:

- Positioning Handle - Cat. No. 188A5532G3
- Wheel and Stab Kit - Cat. No. 194A4378G1

To use a two- or three-high contactor in a one-high enclosure, remove the positioning handle (Fig. 11) and add wheels and bottom stabs. To use a one-high contactor in a two- or three-high enclosure, remove the wheels and bottom stabs and add the positioning handle (Fig. 12).

Up to 360 amperes, contactors with fuse clips will accommodate all the 2.4-kv and 4.8-kv EJ-2 fuses Size D or DD. No change of fuse clips is required for any of the D or DD fuses. To change from a 2.4-kv fuse to a 4.8-kv fuse, the upper clip is repositioned for the two different fuse lengths. (See GEH-3102.)

Limitamp equipment rated higher than 360 amperes and up to 630 amperes continuous, utilizes a contactor having essentially the same basic design but with current-carrying parts of higher capacity. Tips are larger and operate under higher contact pressure. Stabs have special silver-inlaid surfaces for greater conductivity. Fuse mounting is by bolt-on brackets rather than by spring clips. To change from a 2.4-kv to a 4.8-kv fuse, the lower bracket is repositioned for the two different fuse lengths. (See GEH-3102.) Although the dimensions of the higher capacity contactor are essentially the same as the 360-ampere contactor, interchanging them is not recommended.

Air-break contactors are magnetically operated by either a-c or d-c, depending upon circuit requirements. Contactors rated 360 amperes and below are normally, but not always, operated by 230-volt a-c, while those above the 360-ampere rating are operated by d-c from rectifiers included with the equipment. Minimum closing voltage is 85 percent of coil-rated voltage, and dropout voltage varies considerably between a-c and d-c magnets, but the dropout voltage for an a-c magnet could be as high as 70 percent of coil-rated voltage.

Contactors may be supplied with single-phase trip bar and a latching mechanism. The anti-single-phase trip bar offers anti-single-phasing protection resulting from blown fuses. Fig. 12A shows the trip bar mounted on a 700-ampere contactor. Refer to GEH-3102 for a complete description.

The latched-contactor function is used where it is desired that the contactor stay closed during severe undervoltage conditions. Applications include fire pumps or transformer feeders. The

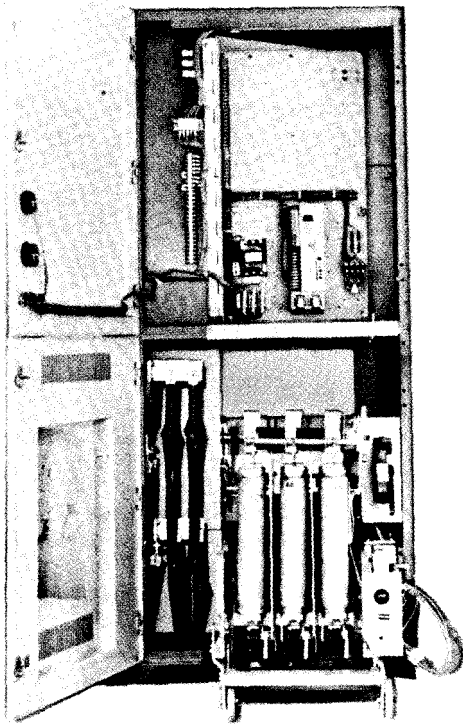

*Fig. 9. 42-inch-wide enclosure with 630-ampere power fuses mounted on contactor.*

latched contactor is available with or without manual release and latch, and with or without electrical release and latch. Refer to Fig. 12B and GEH-3102.

Interrupting capacity of the contactors without fuses is shown in the table on page 5.

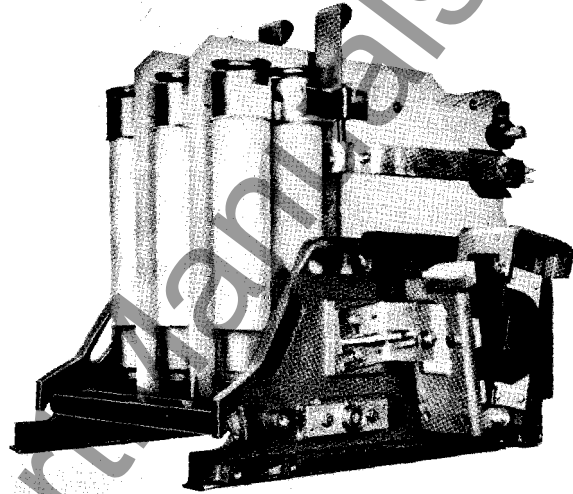

*Fig. 11. High-voltage contactor with Size DD fuses (for mounting in two- or three-high enclosure).*

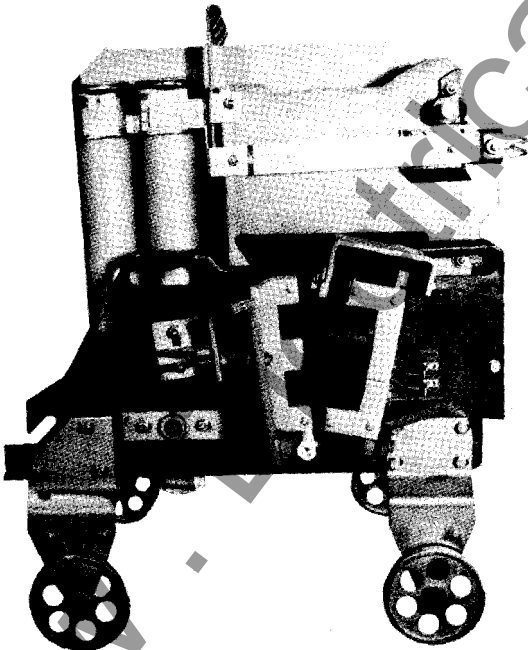

*Fig. 10. High-voltage contactor with wheels and Size DD (360-ampere maximum) fuses.*

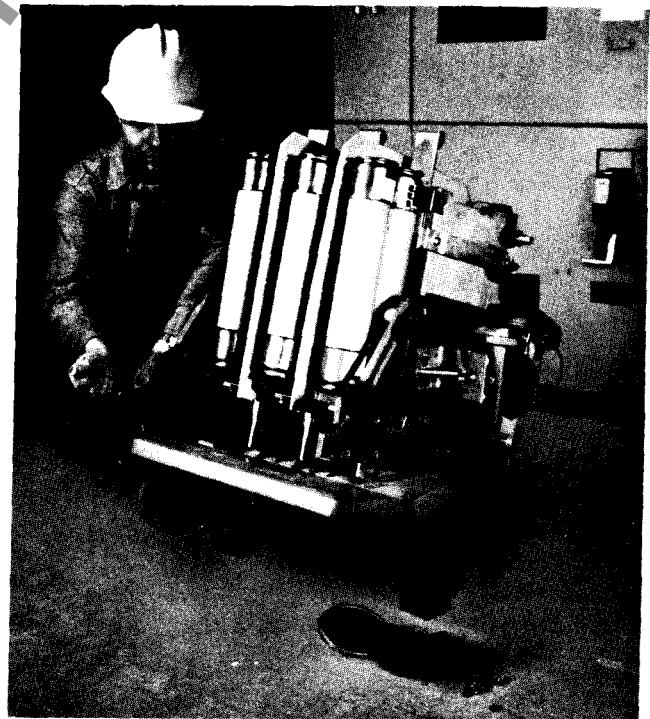

*Fig. 12. Changing one-high contactor to three-high contactor.*

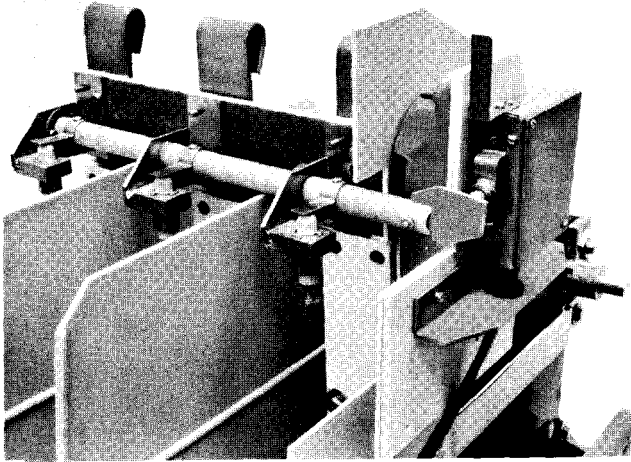

Fig. 12A. Anti-single-phase trip bar mechanism shown without fuses.

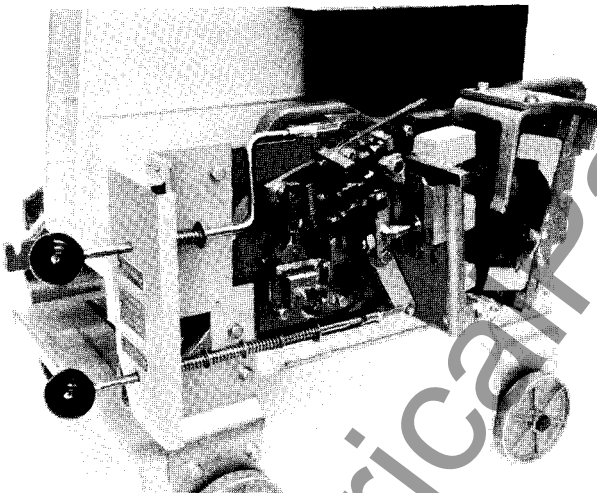

Fig. 12B. Latching mechanism on one-high contactor.

### MANUAL DISCONNECT OR ISOLATING MECHANISM

Limitamp controllers, following the NEMA definition, contain means for manually isolating the power circuit by operation of a disconnecting device. The disconnecting mechanism consists essentially of non-loadbreak finger-type stab assemblies mounted on a portion of the drawout contactor which is free to rotate. Rotation disengages the stabs from the vertical bus (Fig. 13). An insulated shutter linked to the operating mechanism covers the points of vertical bus exposure, thus effectively isolating all live parts inside the controller when the disconnect mechanism is in the OFF position.

Load current is NOT interrupted by the finger stabs. A mechanical interference interlock ensures that the contactor tips are open before the isolating mechanism can be operated.

The mechanical isolator may be padlocked to prevent operation. See Fig. 8.

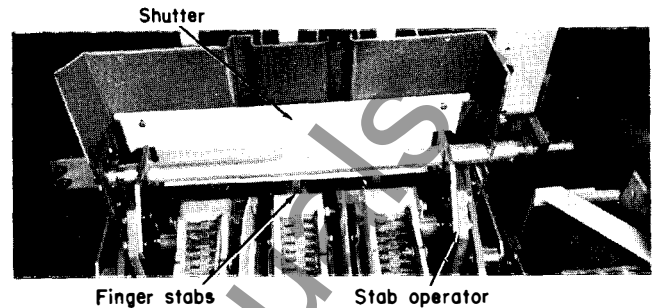

Fig. 13. Limitamp controller manually operated disconnecting stabs and shutter.

### MECHANICAL INTERLOCKING

Limitamp equipment is designed for the high-voltage contactor to do all normal load current interrupting. Fuses generally interrupt fault currents. THE MANUAL ISOLATOR WILL NOT INTERRUPT ANY LOAD OR FAULT CURRENT. A mechanical interference system is included with all Limitamp controllers (mechanical interlock), which prevents opening of the manually operated isolating contacts unless the high-voltage contactor itself is demonstrated by magnet position to already be open. This is to ensure that the contactor has opened the power circuit and interrupted the current. THE MANUAL ISOLATOR SHOULD NEVER BE FORCIBLY OPERATED. Its mechanical interference interlock should be defeated only by knowledgeable and qualified electrical maintenance personnel who have de-energized all power feeding the controller. (See page 34.)

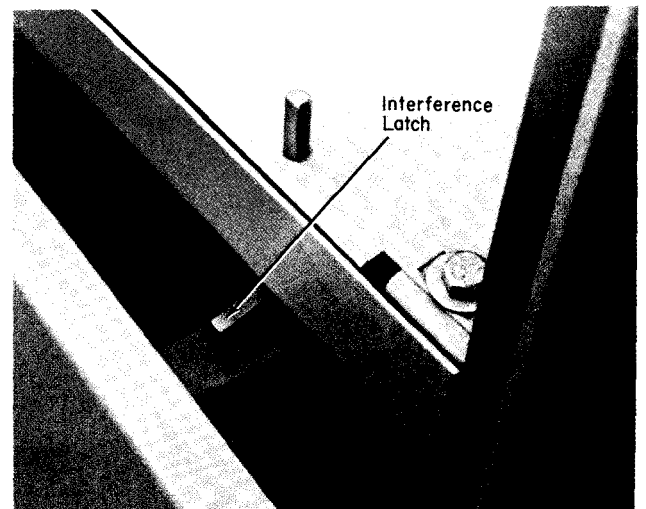

Fig. 14. Interference latch.

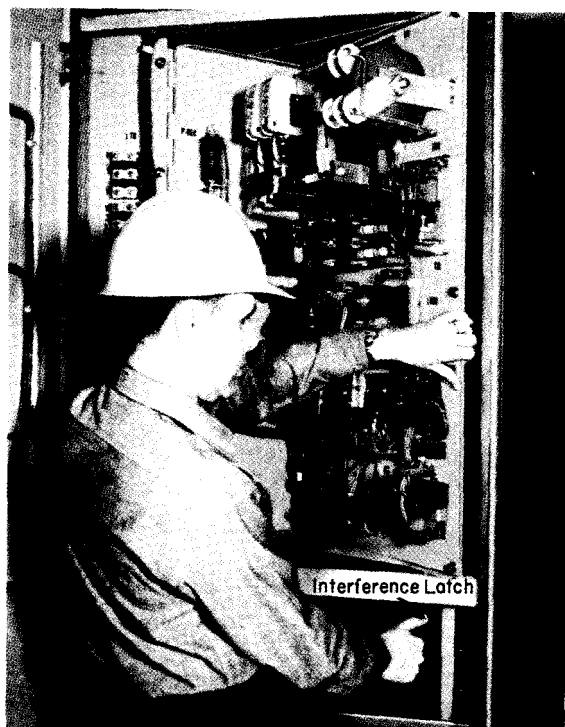

Fig. 15. Release of interference latch.

*NOTE: There is no emergency condition that can justify forcible operation of the manual isolator with the main contactor closed. The isolator must be operated only with the contactor open.*

All high-voltage doors are locked closed by mechanical interference mechanisms linked to the manual isolator so the doors cannot be opened unless the isolator is open. This is done to prevent exposure to high voltage. Bottom doors of one-high starters cover high-voltage compartments, and right-hand doors of two- and three-high starters are high-voltage doors. Other high-voltage doors may be full height to cover reactors or autotransformers, or other auxiliary apparatus (Fig. 16).

Key interlocking is frequently used in lieu of mechanical interference mechanisms to lock high-voltage doors closed until power inside has been removed. Non-loadbreak switches are also key interlocked to prevent operation under load. In all cases of key interlocking, it is important to follow the sequence as described on the drawings furnished with the equipment.

On some one-high enclosure designs, a low-voltage control panel mounted by hinges to the left side of the enclosure serves as a barrier to isolate the high-voltage control power transformer and fuses. An interference latch, shown in Fig. 14, prevents swinging this panel out until the high-voltage door

is opened, thus ensuring that high-voltage power to the CPT is disconnected. Fig. 15 shows the method by which the interference latch can be released when the high-voltage door is open.

#### AUXILIARY ENCLOSURES

Many sizes of enclosures are furnished in Limitamp control lineups for various purposes. Some are tabulated below:

- Bus transitions to switchgear
- Bus transitions to transformers
- Cable entrance compartments
- Rectifier exciter compartments
- Starting reactor or autotransformer compartments
- Relay and metering compartments
- Instrument transformer compartments
- Manual switch compartments

#### DIMENSIONS

Limitamp controllers are normally 30 inches deep and 90 inches high. Width varies with one-high, two-high and three-high and cable space requirements, and with ampere capacity over 360 amperes. See the APPENDIX of these Instructions for typical outline dimensions.

#### POWER FUSES

Current-limiting fuses, Type EJ-2, are used for 360-ampere high-interrupting-capacity motor controllers. Bolt-on current-limiting power fuses are the only ones available for contactors rated 360-amperes or higher. Bolt-on current-limiting power fuses are required for all ampere ratings to obtain the anti-single-phase blown fuse trip bar function. Coordination information for both types of fuses can be found in GES-5000. Interrupting ratings are as shown on Page 5 of these instructions.

Transformer feeders frequently contain Type EJ-1 current-limiting fuses, as described in GES-5002.

#### STARTING AUTOTRANSFORMERS AND REACTORS

Reduced-voltage starters include a reactor or autotransformer designed for starting duty in accordance with NEMA ICS2-214. The duty cycle is for medium-duty applications, which consists essentially of three 30-second starts spaced 30 seconds apart, followed by a one-hour rest. A heavier-duty cycle will cause overheating and possible damage to the reactor or transformer. Thermostats are mounted on the reactor and transformer cores to offer protection against overheating. These thermostats must be manually reset if tripped by high temperature.

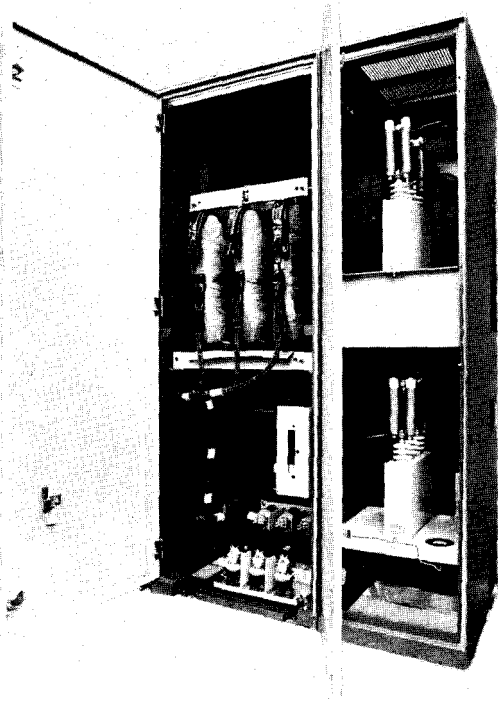

Fig. 16. Limitamp auxiliary enclosures for housing motor-starting reactors and power-factor-correction capacitors. Doors are mechanically interlocked.

## INSTALLATION

### GENERAL

This section contains information on receiving and handling, disassembly, power-cable termination, grounding, and reassembly to make the equipment ready for operation.

### RECEIVING

Limitamp controllers are fabricated as rigid, floor-mounted, self-supporting steel sections requiring no floor sills. They are crated and shipped in an upright position and, when received, should be kept upright.

*NOTE: There are some exceptions to this, which allows handling in the flat with some components removed for shipment.*

Some components may be shipped separately, such as top-mounted resistors or potential transformers. These components are identified by catalog number coinciding with that of the section on which they are to be mounted.

Corrugated cardboard is normally used for domestic crating, with the steel enclosure sections bolted to a wooden skid, and the cardboard fastened to the wooden skid. See Fig. 17. After receiving, the cardboard may be removed, and the equipment, as shown in Fig. 18, handled on the wooden skid.

### HANDLING

It is always preferable to handle Limitamp controllers by the lifting means provided. Figure 19 shows the recommended method of lifting a single section, while Fig. 20 shows the recommended method of lifting a lineup.

Note that the lineup in Fig. 20 is suspended from an equalizing bar. A lineup should be supported at as many points as possible. If there is not enough headroom to lift the panel by its lifting beam, then a track jack, as shown in Fig. 21, can be used.

Figure 21 shows how a Limitamp controller can be raised by placing a track jack under the shipping skid, and how rollers can then be placed under the skid for rolling the equipment to its final location. The panel should then be raised by its lifting beam, the shipping skid removed, and the panel set into place.

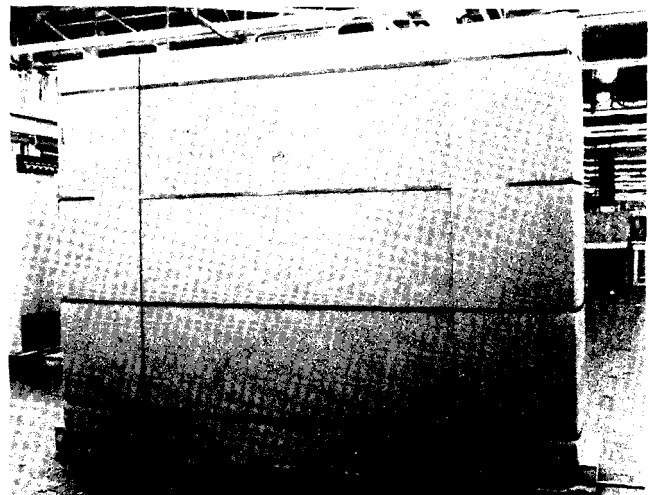

Fig. 17. Limitamp controller crated in corrugated cardboard.

The use of fork-lift trucks is not recommended, since the forks may damage the enclosure or interior parts of the equipment. If no other method of handling is available, the forks must go under the skid bottom to avoid damaging the equipment.

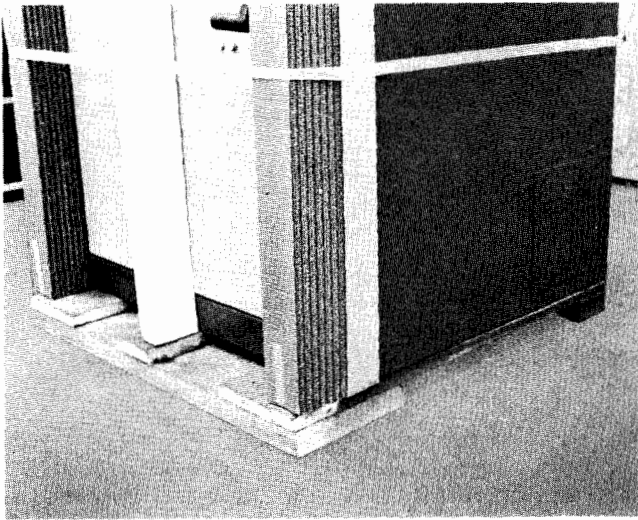

Fig. 18. Limitamp controller with outside corrugated cardboard removed. Ready for handling.



Fig. 20. Recommended method of lifting a Limitamp lineup. Note that the lineup is suspended from an equalizing bar.

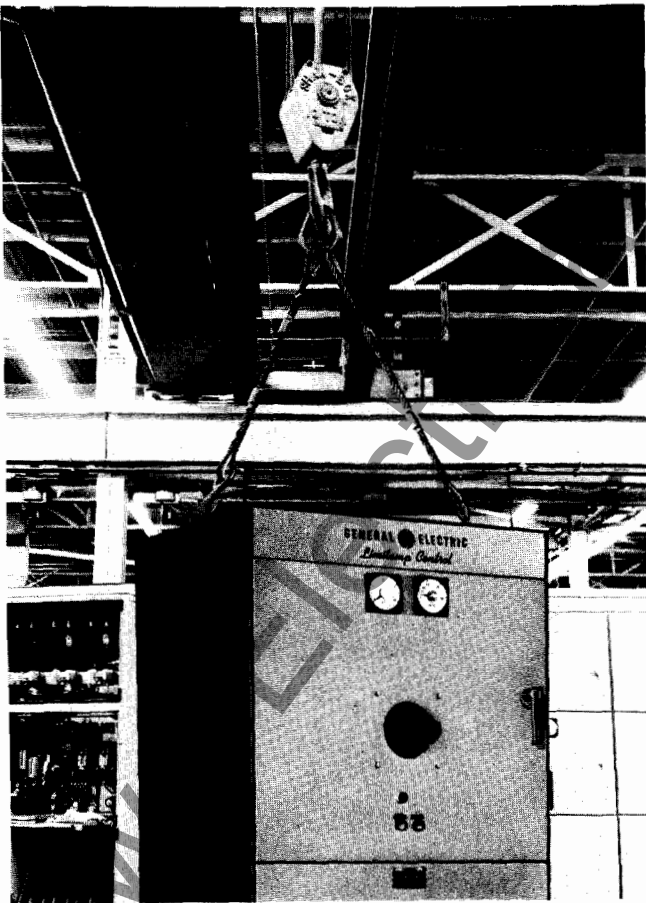

Fig. 19. Recommended method of lifting a single panel.

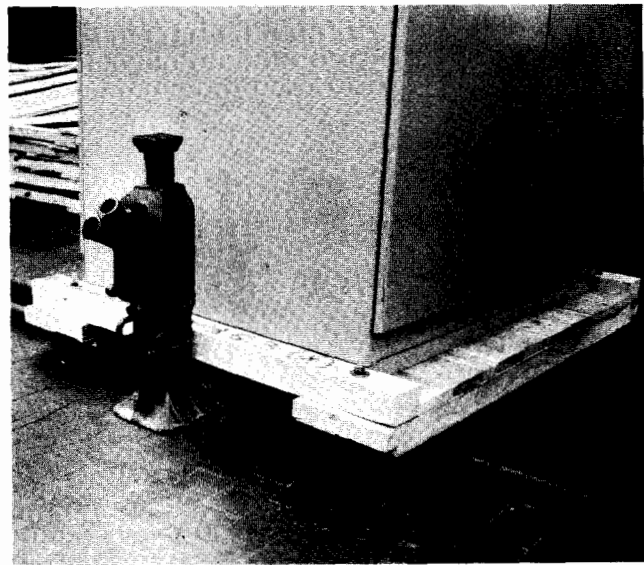

Fig. 21. Shipping skid raised by track jack allows room for rollers under the skid.

**PLACEMENT OF ENCLOSURE**

It is essential that the panel be securely fastened in a true upright position on a level surface to permit proper operation of the devices. It should be located on the floor surface so that the contactor can be rolled out, and this floor surface on which the panel will stand should be carefully prepared and made as level as possible.

When the panel has been put into place, it should be checked for levelness and shimmed if necessary. Inasmuch as the contactor is of the drawout type, no shims should be placed under the front portion unless the floor will later be built up in order to eliminate raised surfaces over which the contactor would have to be moved when entering and leaving the enclosure. The panel can then be bolted to the floor by means of 1/2-inch bolts for which holes are provided in the front and rear of the bottom of the enclosure. Refer to the outline furnished with each panel for the floor plan showing the location of these bolts.

**DISASSEMBLY—ONE-HIGH DESIGN**

After the equipment has been set in place where it is to be permanently connected, some internal disassembly is required to make the necessary external power-cable and control-wire connections. Disassembly should be done in a definite sequence by following Fig. 22 through Fig. 31, and as described below:

**Disassembly Sequence of Operation**

*CAUTION: NO POWER SHOULD BE CONNECTED TO THE CONTROLLER.*

1. Move the manual isolator handle to the OFF position. Refer to the nameplate attached to the high-voltage door near the handle. Fig. 22 shows the method of first depressing the pusher with one hand and moving the handle with the other. Refer to page 34 for normal and emergency door opening procedures.
2. Open both the top (low-voltage) and bottom (high-voltage) doors.

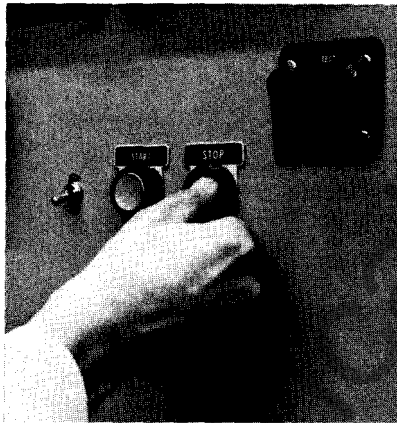

1. Push STOP button

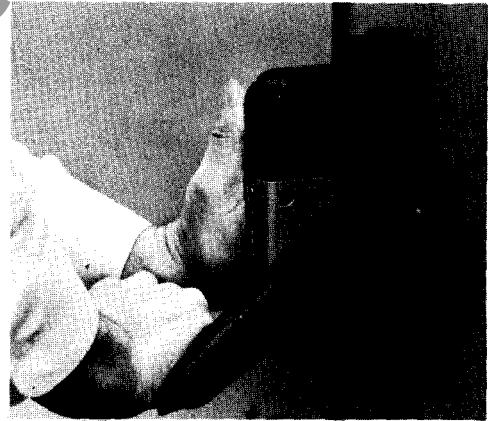

2. Operate handle



3. Handle OFF - pusher out

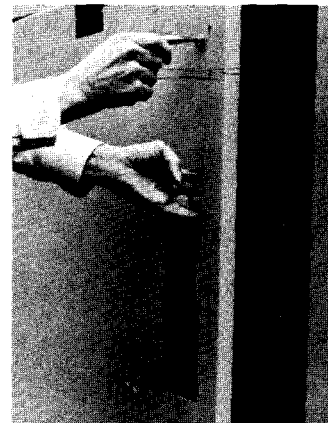

4. Turn latches and open door

Fig. 22. To open high-voltage door.

## GEH-3091C, IC7160 Limitamp® Controllers

3. Remove the lintel at the bottom of the enclosure (Fig. 23 and Fig. 24).

4. Remove the positioning bolt on the high-voltage contactor (Fig. 25).

5. Roll out the contactor (Fig. 26 and Fig. 27).

6. Prepare to remove the horizontal compartment barrier by removing the bolts shown in Fig. 28.



Fig. 23. Release of lintel removal catch on right end.



Fig. 25. One-high contactor in enclosure showing positioning bolt that must be removed to roll out contactor.

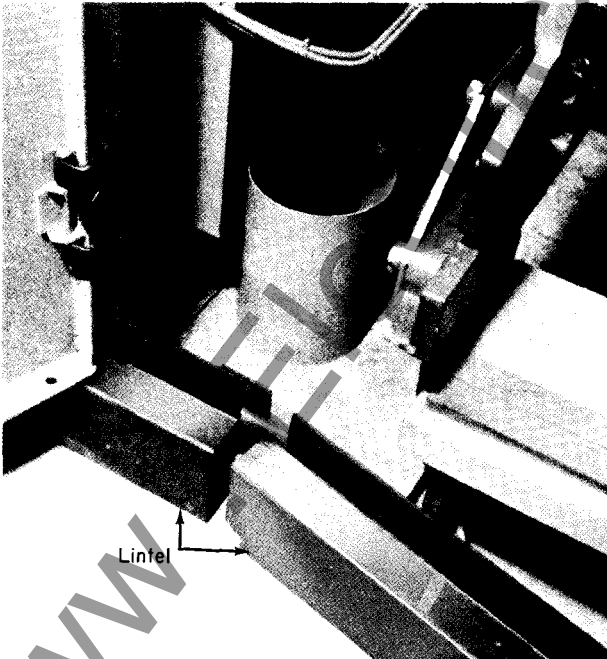

Fig. 24. Lintel removal - left end.



Fig. 26. Roll contactor out of enclosure.

7. Remove the horizontal barrier, Fig. 29. (If a hinged low-voltage panel is used, swing it to the left and out of the enclosure.)

8. Remove the horizontal bus barrier bolts as shown in Fig. 30, and then lift the barrier out of the enclosure. The horizontal bus is then exposed as shown in Fig. 31.

After the preceding steps have been completed, all power termination points and bus connections are accessible.

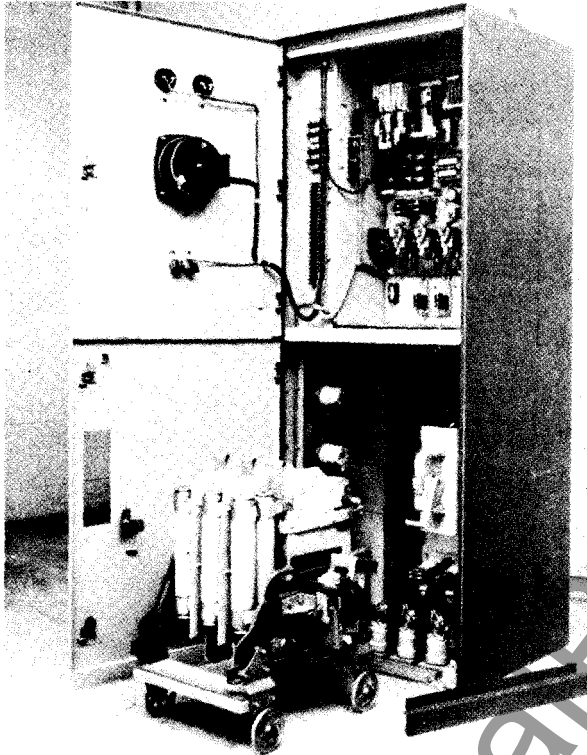

Fig. 27. Contactor rolled out of one-high enclosure.



Fig. 29. Horizontal shelf and barrier removal.

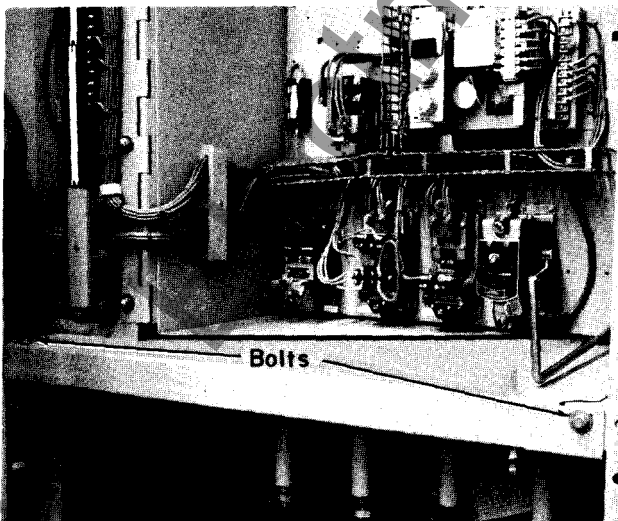

Fig. 28. Bolts to be removed to remove horizontal shelf and barrier.

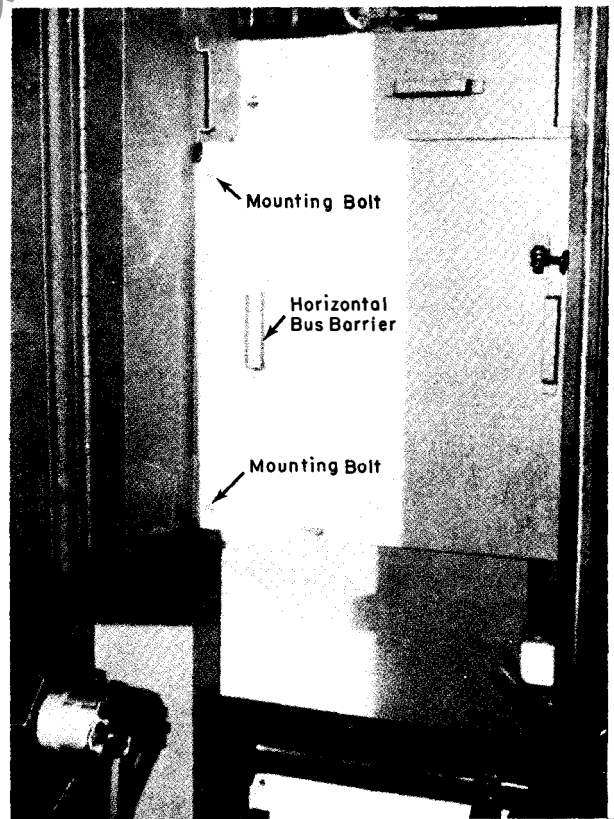

Fig. 30. Horizontal bus barrier and mounting bolts.

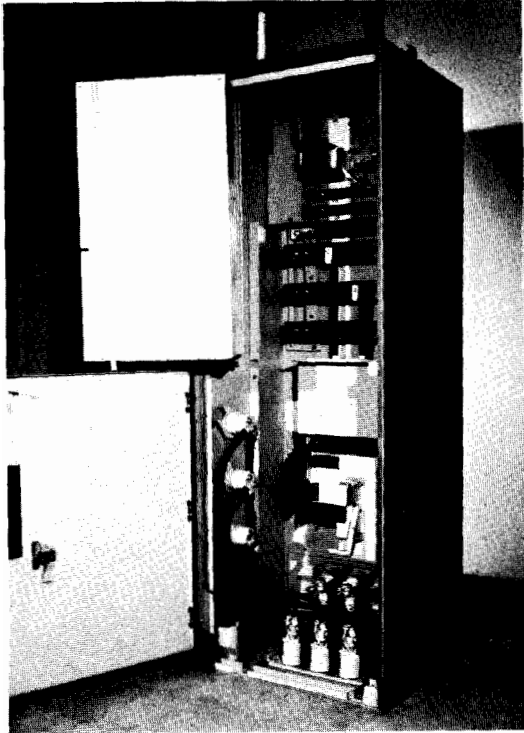

Fig. 31. One-high enclosure with contactor and barriers removed, showing left side of enclosure and terminal points on bus.

#### DISASSEMBLY — TWO-HIGH DESIGN

After the equipment has been set in place where it will be permanently connected, some internal disassembly is required to make the necessary external power-cable and control-wire connections. Disassembly should be done in a definite sequence by following Fig. 32 through Fig. 42, and as described below:

#### Disassembly Sequence of Operation

**CAUTION: NO POWER SHOULD BE CONNECTED TO THE CONTROLLER.**

1. Move the manual isolator handle to the OFF position. Refer to the nameplate attached to the high-voltage door near the handle. Fig. 22 shows the method of first depressing the pusher with one hand and moving the handle with the other.

2. Open the high-voltage door (Fig. 32).

3. Remove the contactor positioning bolt (Fig. 33).
4. Pull the contactor forward against the retaining latch (Fig. 34 and 35).
5. Use contactor lift to remove the contactor from the enclosure (Fig. 36).
6. Remove the lower contactor in the same manner.
7. Disconnect the high-voltage leads to the control power transformer (Fig. 37).
8. Remove both track assemblies (Fig. 38).
9. Remove the horizontal barrier (Fig. 39).
10. Remove the upper left-side barrier (Fig. 40).
11. Remove the two left-side rear barriers (Fig. 41).
12. Remove the right-side barrier (Fig. 42).

After the preceding steps have been completed, all power termination points and bus connections are accessible.

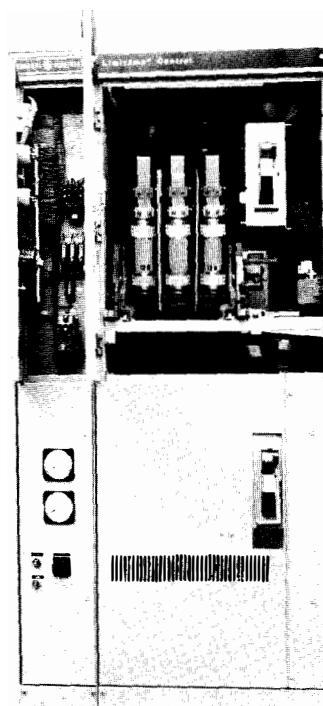
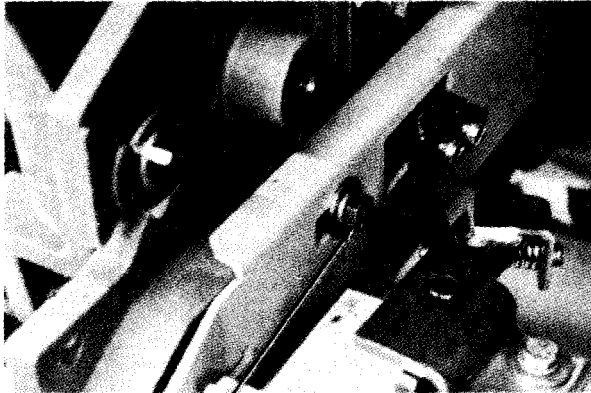

Fig. 32. Two-high enclosure with top high-voltage door open.



Positioning Bolt

Fig. 33. Closeup of contactor, showing positioning bolt.



Fig. 35. Closeup of contactor, showing retaining latch.

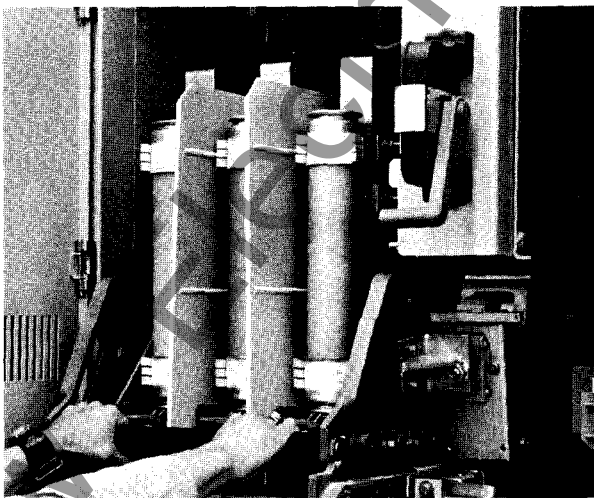

Fig. 34. Pulling on contactor handle.



Fig. 36. Removing contactor, using Cat. No. 116C9918G1 lift.

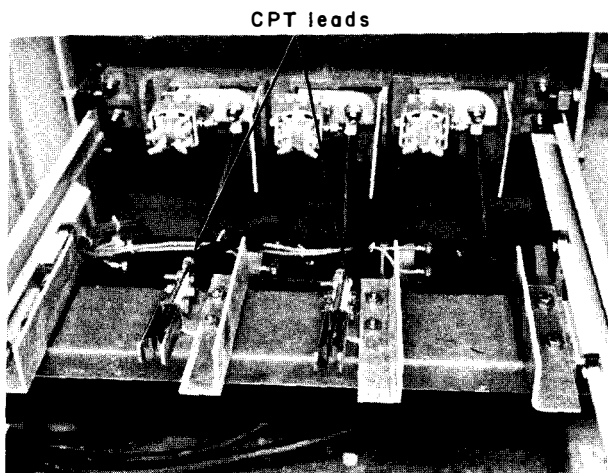

Fig. 37. Closeup of contactor, showing CPT leads on track.

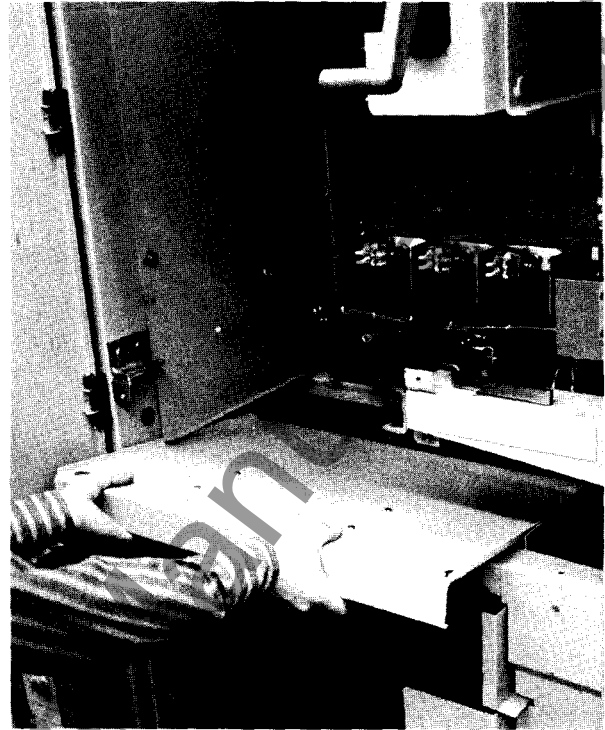

Fig. 39. Removing horizontal barrier.

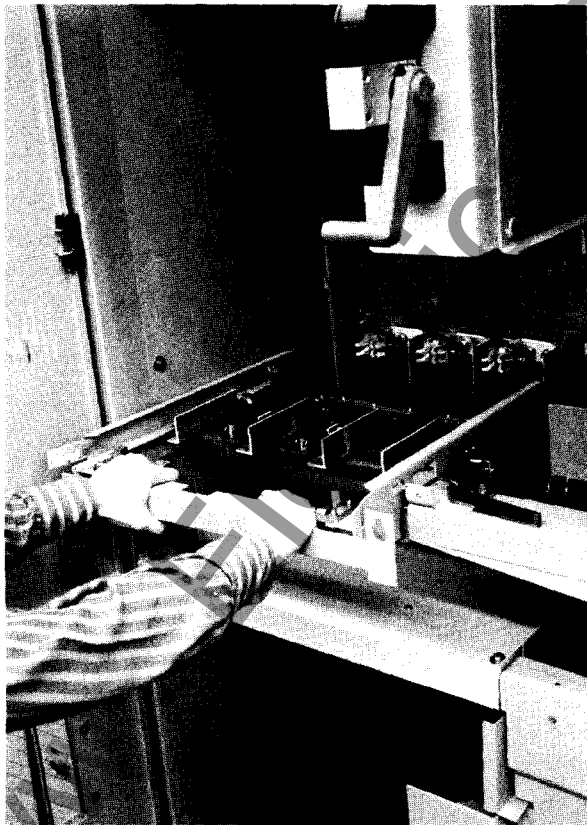

Fig. 38. Closeup of track removal.

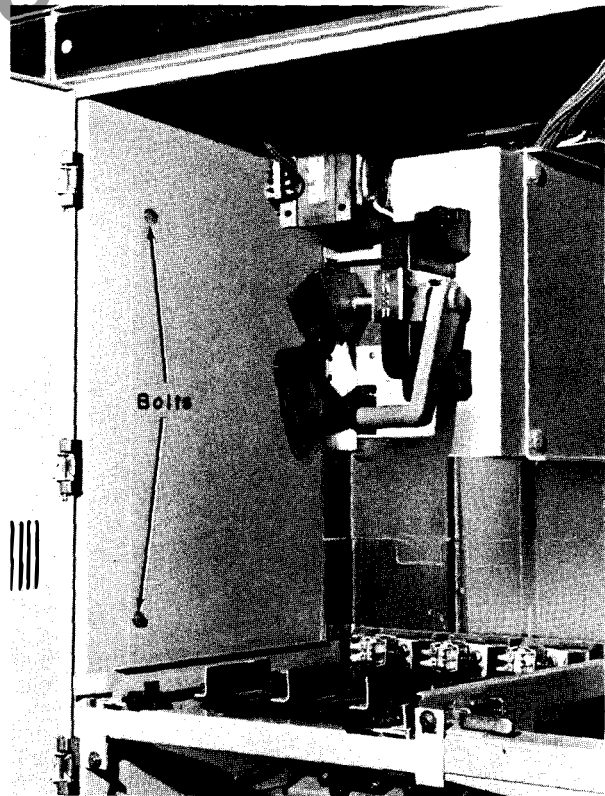

Fig. 40. Closeup of top compartment, showing retainer bolts to be removed.

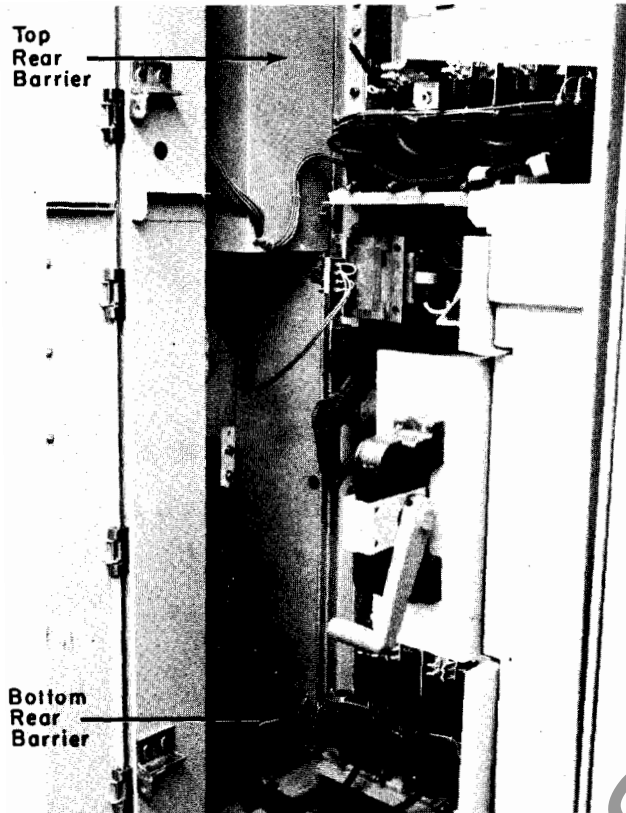

Fig. 41. Inside view of compartments, showing top and bottom rear barriers.

2. Open the high-voltage door (Fig. 43).
3. Remove the contactor positioning bolt (Fig. 44).
4. Pull the contactor forward against the retaining latch (Fig. 45 and 46).
5. Use the contactor lift to remove the contactor from the enclosure (Fig. 47).
6. Disconnect the high-voltage leads to the control power transformer (Fig. 48).
7. Remove the left-side barriers (Fig. 49 and Fig. 50).
8. Remove the contactor tracks (Fig. 51 and Fig. 52).

After the above eight steps have been completed, all power termination points and bus connections are accessible.

#### DISASSEMBLY—THREE-HIGH DESIGN

After the equipment has been set in place where it will be permanently connected, some internal disassembly is required to make the necessary external power-cable and control-wire connections. Disassembly should be done in a definite sequence by following Fig. 43 through Fig. 54 and as described below:

#### Disassembly Sequence of Operation

**CAUTION: NO POWER SHOULD BE CONNECTED TO THE CONTROLLER.**

1. Move the manual isolator handle to the OFF position. Refer to the nameplate attached to the high-voltage door near the handle. Fig. 22 shows the method of first depressing the pusher with one hand and moving the handle with the other.

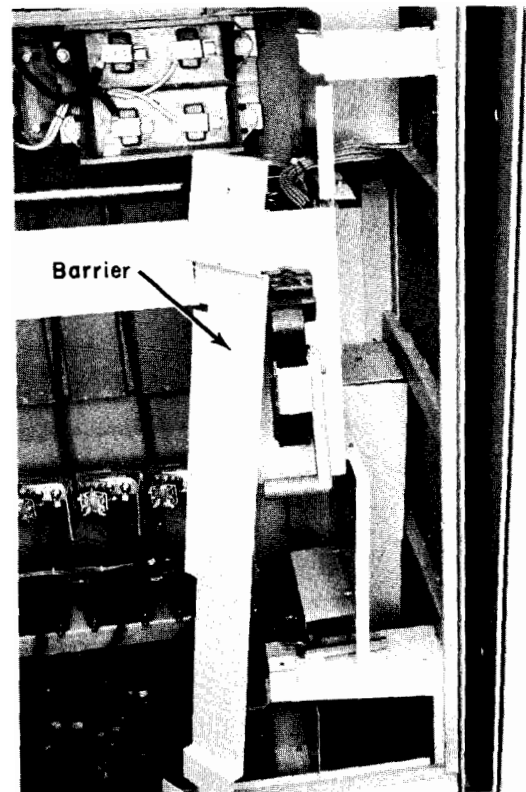

Fig. 42. Front view of right-hand side bottom with front barrier removed.

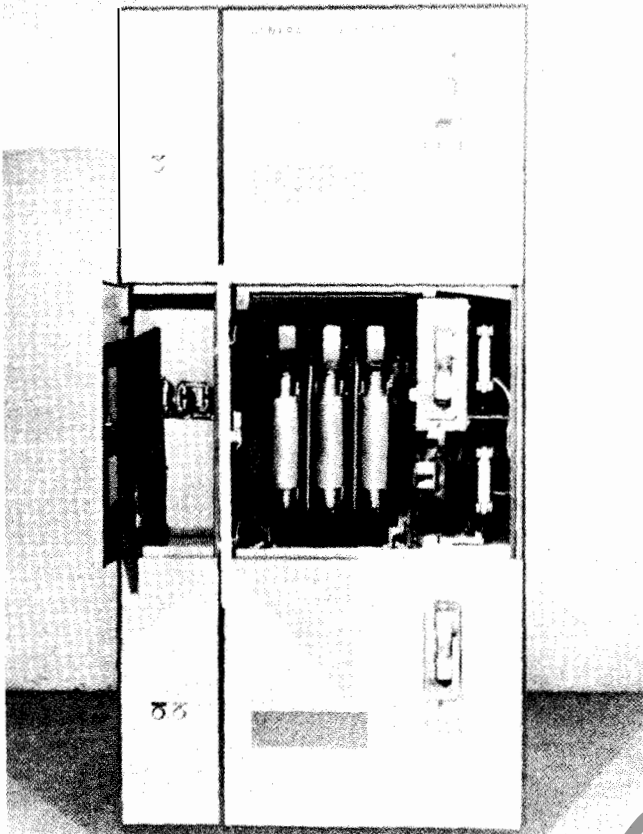
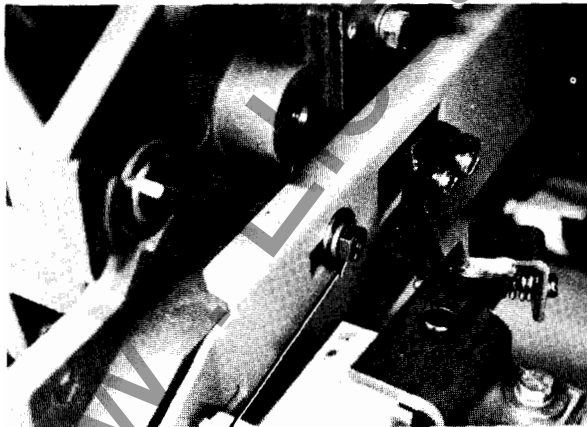

Fig. 43. Three-high enclosure with high- and low-voltage doors open showing main fuses, control-power transformer fuses and control fuses.

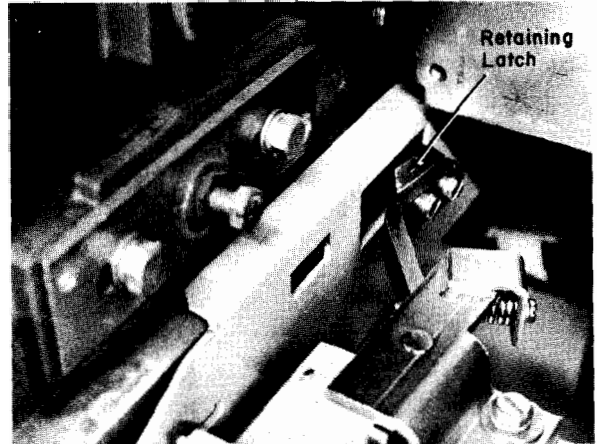

Fig. 45. Pulling on contactor positioning handle.



Positioning Bolt

Fig. 44. Closeup of contactor, showing positioning bolt.



Retaining Latch

Fig. 46. Closeup of contactor, showing retainer latch.

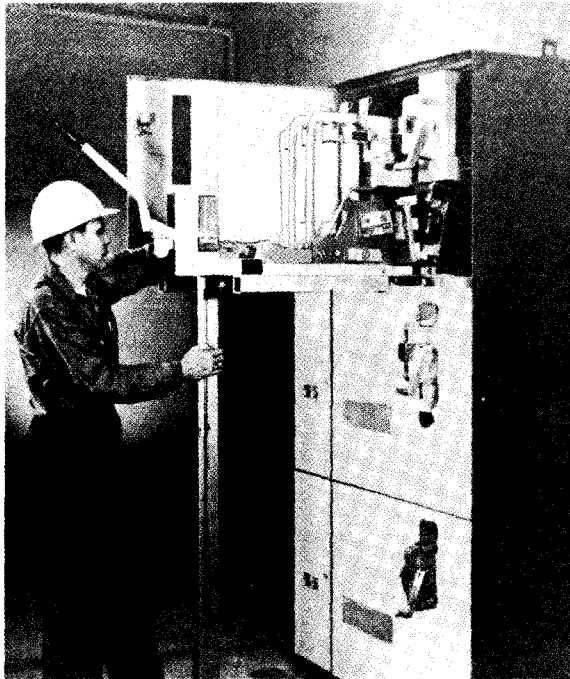

Fig. 47. Removing contactor, using Cat. No. 116C9918G1 lift.

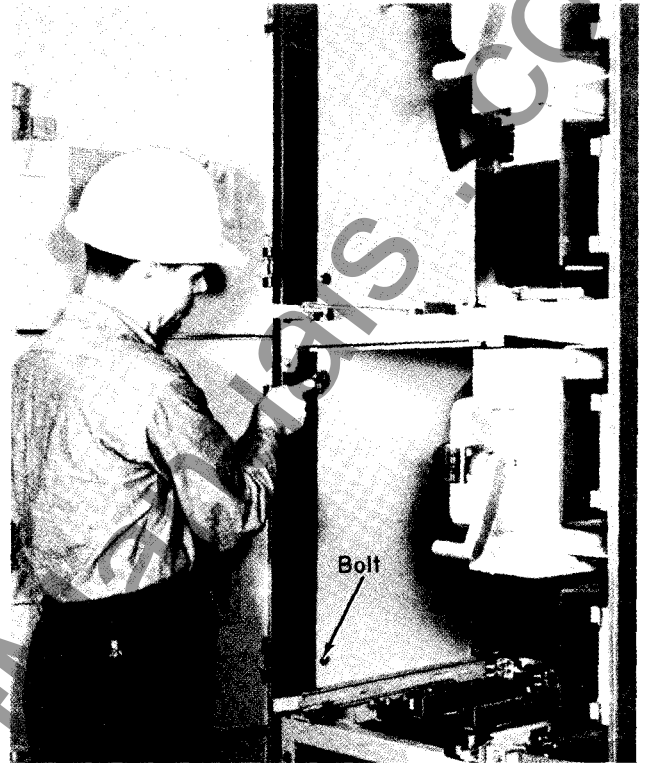

Fig. 49. Loosening of bolt holding side barriers in three-high enclosure.

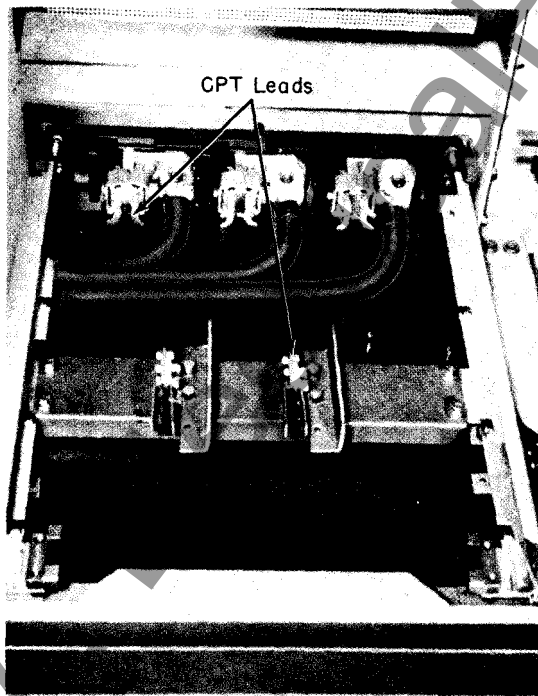

Fig. 48. Leads from the control power stabs.



Fig. 50. Removing bolts in track and horizontal barrier assembly in three-high enclosure.

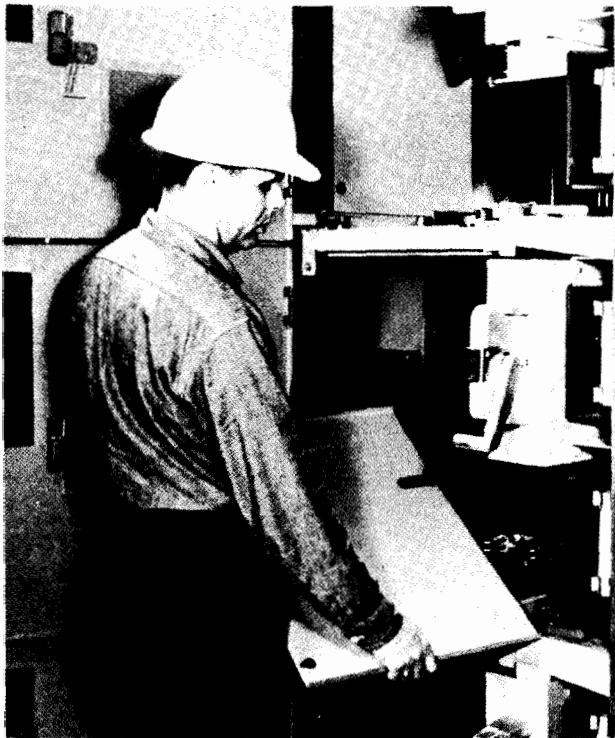

Fig. 51. Removal of side barrier in three-high enclosure.

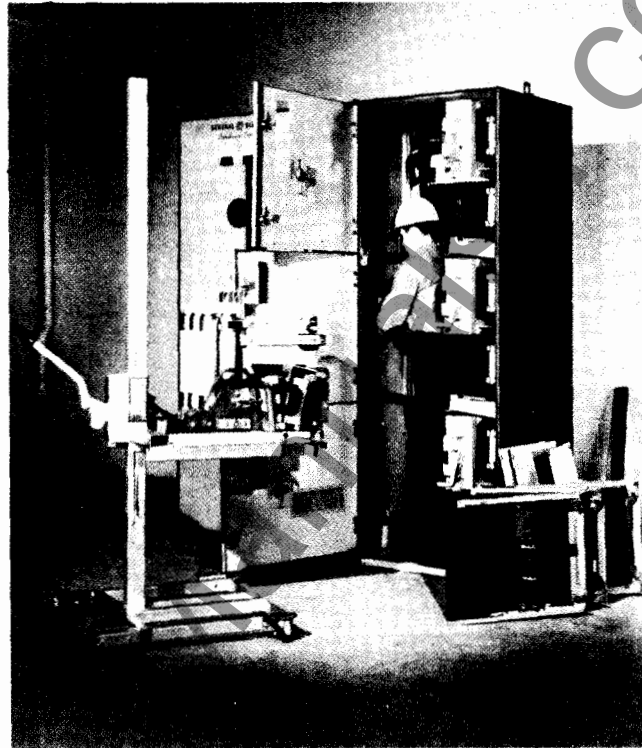

Fig. 53. Contactors and barrier removed from the enclosure for installation.

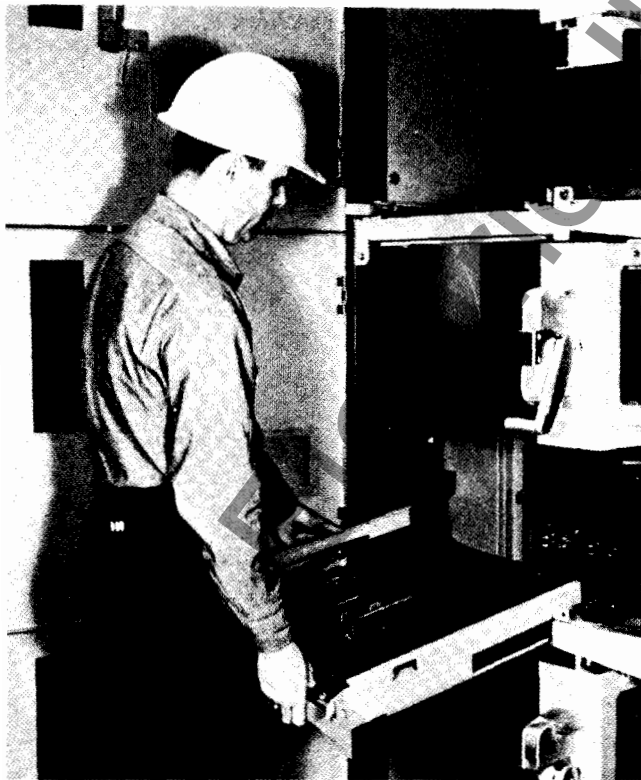

Fig. 52. Removal of track and horizontal barrier assembly in three-high enclosure.

#### GROUNDING

All starter enclosures of the one-high, two-high and three-high design must be grounded. A stud is welded to the lower back of the enclosure in the incoming-line compartment area for connection to the grounding system. This connection must be made before making any power connection.

The control and instrumentation circuits are grounded to the enclosure at the terminal board. This is the only grounding point. It can be temporarily removed for test purposes; but it must be re-grounded before the control is returned to operation.

#### INCOMING POWER CONNECTIONS

Incoming power connections to the bus may be made in any one of the enclosures in a lineup. Two 500-mcm cables per phase, with an outside diameter of 13/16 inch, can be accommodated in all three enclosures. However, space for stress cones on two 500-mcm per phase is not available. If shielded cable is used, refer to page 29.

### One-high Enclosure

In the one-high enclosure with horizontal power bus, incoming power connections are made at the left side of the enclosure. When the contactor and barriers are removed from the one-high enclosure, both ends of the main a-c power bus, d-c bus, and ground bus are accessible from the inside of the enclosure. To add additional units to a lineup of enclosures, the new enclosure can be located in position, and with the bus jumpers furnished with the equipment, the bus connections can be made to either side of existing equipment. Figures 54 and 55 show the accessibility of both ends of the bus bars in the one-high enclosure with the contactor and barriers removed and the low-voltage base swung out.

Figure 56 shows the bus cover removed in order to make connections from one enclosure to another with the bus jumpers.

On individual controllers with no horizontal bus, the incoming-power connections are made directly to the ends of the vertical bus. Figure 57 shows these terminal points.

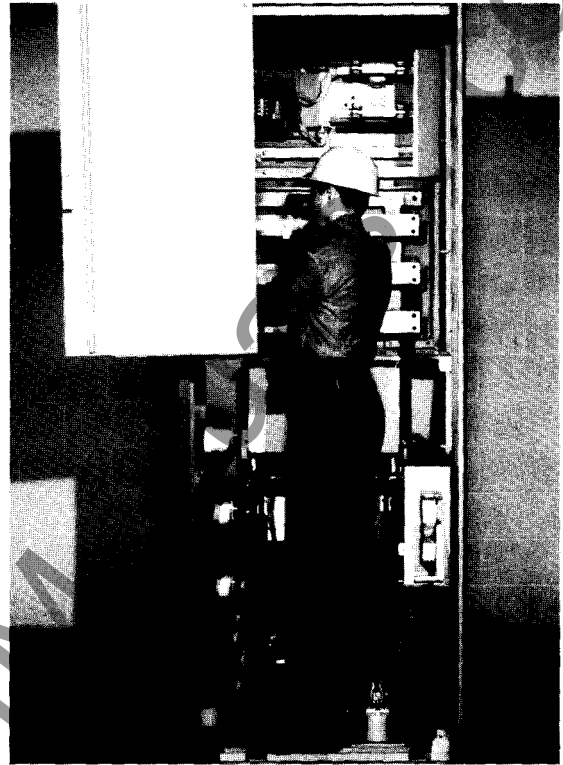

Fig. 55. One-high enclosure with contactor and barriers removed, showing access to right end of bus.



Fig. 54. One-high enclosure with contactor and barriers removed, showing left side of enclosure and terminals on bus.

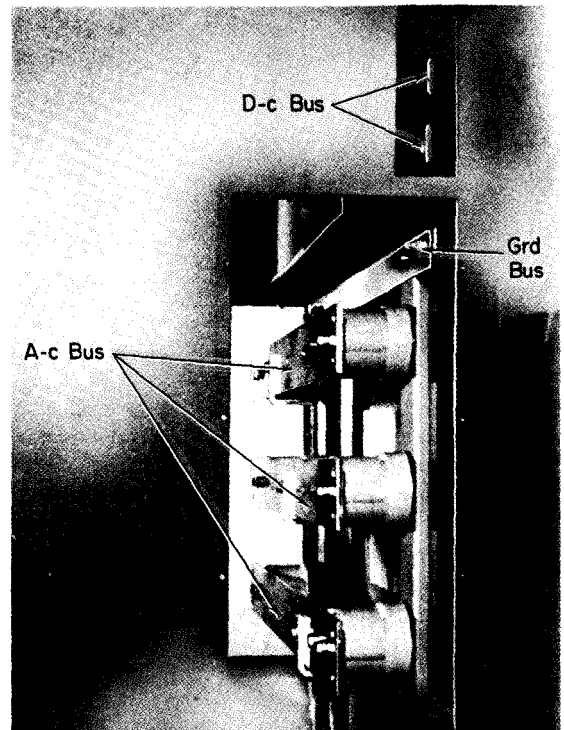

Fig. 56. Bus cover removed, showing d-c bus and a-c bus in one-high enclosure.

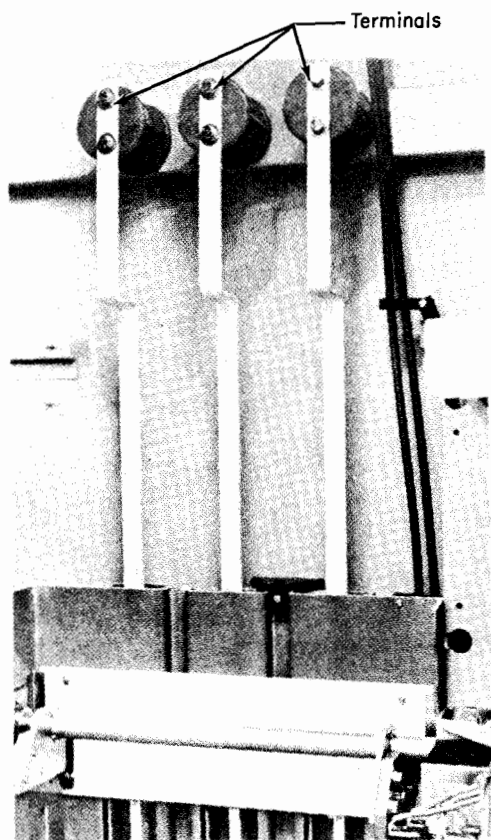

Fig. 57. One-high enclosure without horizontal bus showing terminal points at end of vertical bus.

#### Two-high and Three-high Enclosure

In the two-high and three-high enclosure, the incoming power connections are made on the left side, behind the rear barriers.

With all of the contactors, tracks, and barriers removed from the two- or three-high enclosures, the left-hand end of the main bus, d-c bus, and ground bus are accessible as shown in Fig. 58 and 59. Only the left-hand end of the bus bars in the two- or three-high enclosure is accessible with the contactors and barriers removed. For lining up with other sections, the procedure to be used is discussed in the following paragraph:

If an additional Limitamp controller is to be added to the right-hand side of a two- or three-high enclosure, the bus cover as shown in Fig. 60 should be removed. The bus jumpers supplied should be bolted to the ends of the bus of the existing enclosure before the new enclosure is put into position. Then, the new enclosure can be moved-over horizontally and the connections to the new bus made from inside the new enclosure. Another alternate method of making these connections is to remove the bus covers as shown in Fig. 60. Locate the new enclosure in position beside the existing enclosure. Reach through the new enclosure and make the connections to the old and new bus by working from the new enclosure.

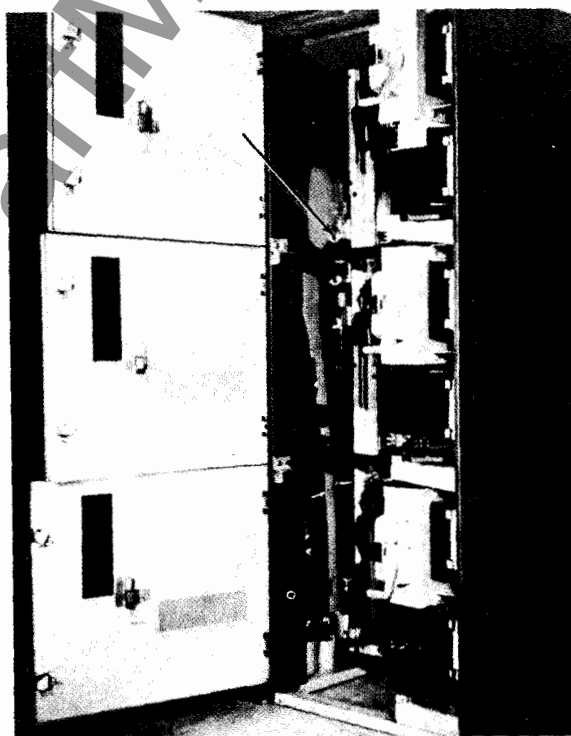

Fig. 58. Three-high enclosure with contactor and barriers removed. The arrow points to an incoming line terminal on the a-c bus.

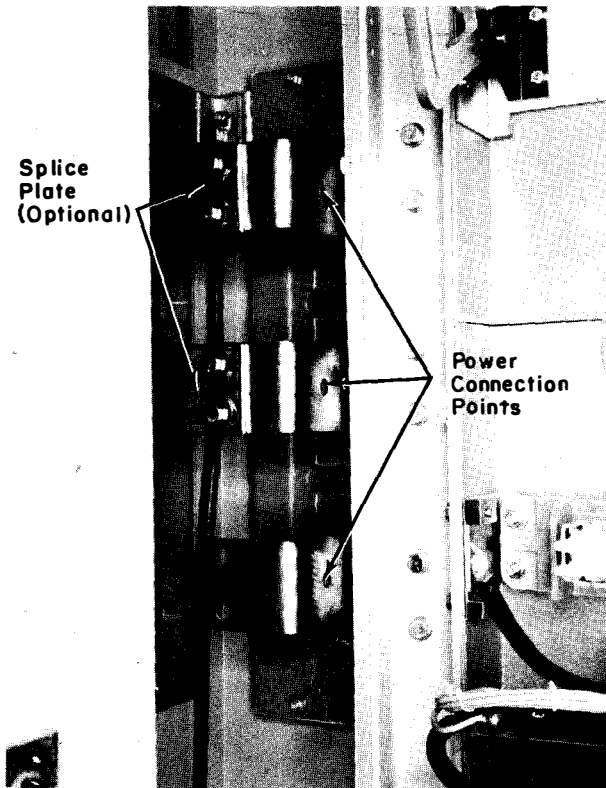

Fig. 59. Closeup of two-high enclosure, showing power connection points and splice plates.

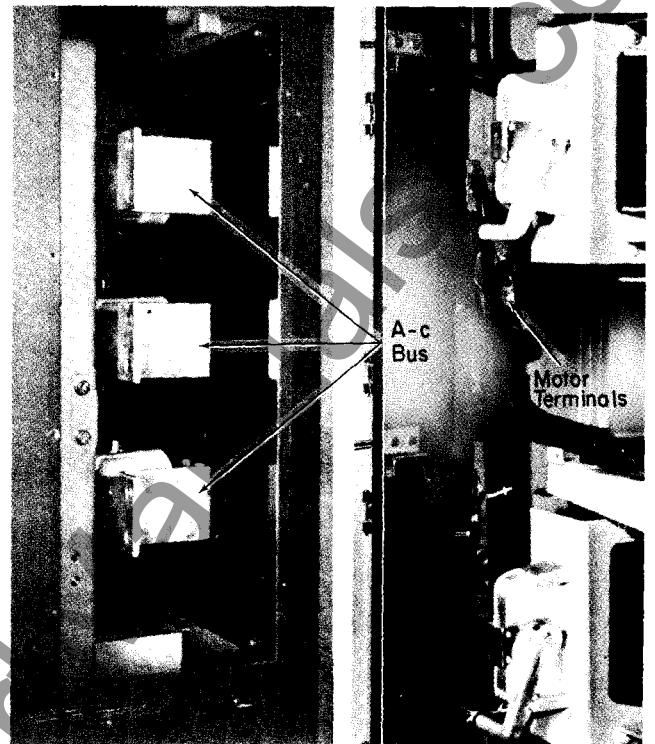

Fig. 60. Bus cover removed, showing a-c bus (left) and motor terminals (right) in three-high enclosure.

## MOTOR CONNECTIONS

### One-high and Three-high Design

Motor connections may be made from either the top or bottom of the enclosure. In the one-high enclosure, the motor terminals are on the lower-left sidewall as shown in Fig. 54. (For a more detailed illustration, see Fig. 78.) The connections may be made before or after energizing the main bus and without shutting down adjacent equipment.

Motor terminals in the three-high enclosure are shown in Fig. 60. All three starters must be de-energized to make any of these connections. However, it is not necessary to de-energize the main bus.

The motor terminals will accommodate one 500-mcm cable per phase. For shielded cable, see page 29.

For detailed instructions on how to remove the contactors and barriers from each of the enclosures, refer to the specific section of these instructions.

### Two-high Design

Motor connections for the two-high starter may be made in two ways - (1) with both starters de-energized and disassembled, or (2) with either starter energized. In both cases, the upper (left-side) and lower (right-side) motor terminals will be accessible from either the top or bottom of the compartment.

A. Termination with both starters de-energized and the handles in the OFF position:

Disassemble the starter per the two-high instructions on page 14, through Step 12.

**CAUTION: DO NOT REMOVE THE REAR BUS BARRIERS.**

Motor termination points for the lower starter are located on the left sidewall. See Fig. 61. Terminations for the upper starter are on the right sidewall. See Fig. 62. Pull the cables and connect to the respective termination points.

**B. Termination with the top starter energized:**

1. Move the lower manual isolater handle to the OFF position. Refer to the nameplate attached to the high-voltage door near the handle. Fig. 22 shows the method of first depressing the pusher with one hand and moving the handle with the other.

2. Open the lower high-voltage door. (See Fig. 6, page 4.)

3. Remove the contactor. (See page 14.)

4. Disconnect the high-voltage leads to the control power transformer. (See Fig. 37, page 16.)

5. Remove the contactor tracks (See Fig. 38, page 16 for method).

6. Motor termination points are now accessible. (Fig. 61.) Connection may be made from either the top or bottom of the enclosure.

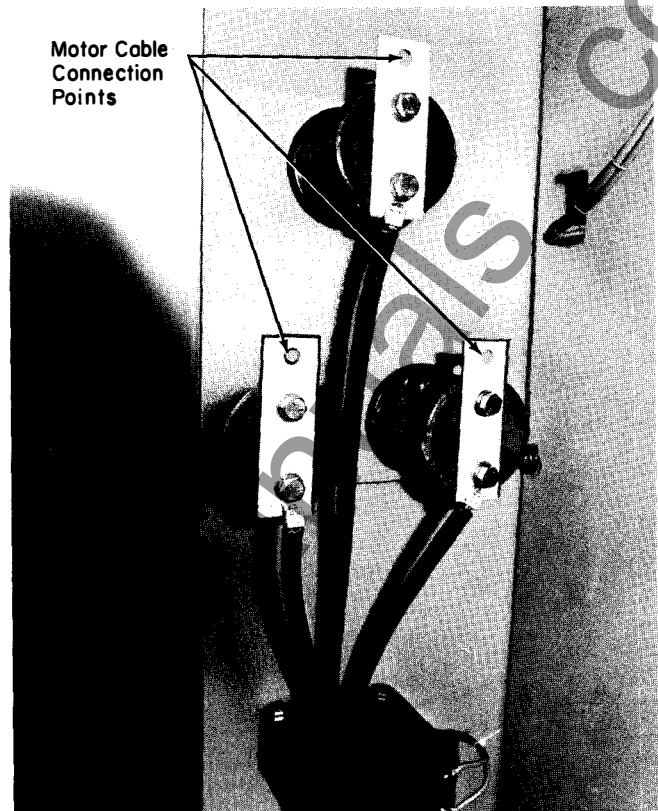

*Fig. 61. Motor termination points for lower starter.*

**C. Termination with the bottom starter energized:**

1. Move the upper manual isolater handle to the OFF position. Refer to the nameplate attached to the high-voltage door near the handle. Fig. 22 shows the method of first depressing the pusher with one hand and moving the handle with the other.

2. Open the upper high-voltage door (See Fig. 63).

3. Use the contactor lift to remove the contactor (See Fig. 36, page 15).

4. Connections may be made to the terminals on the right sidewall, from either the top or bottom of the compartment (Fig. 62).

5. If cables are to be run from the bottom of the enclosure:

a. Open the cable access door on the lower compartment by removing the two bolts and turning the latches. The lower high-voltage door will remain closed.

b. Remove the barrier to allow access to the cabling compartment (Fig. 64).

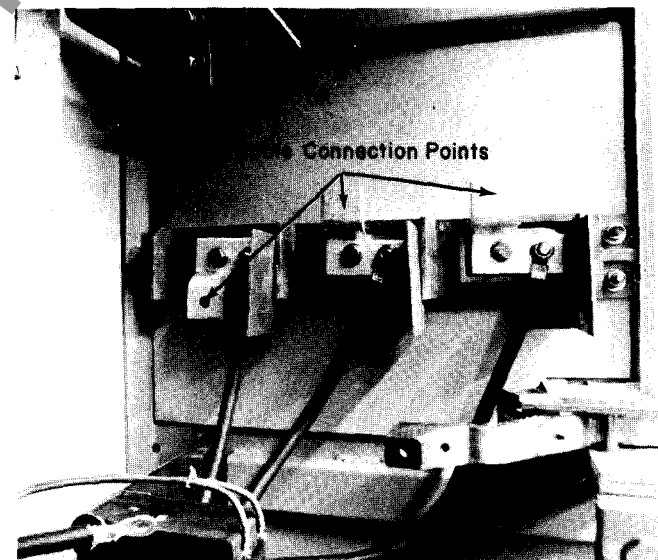

*Fig. 62. Motor termination points for upper starter.*

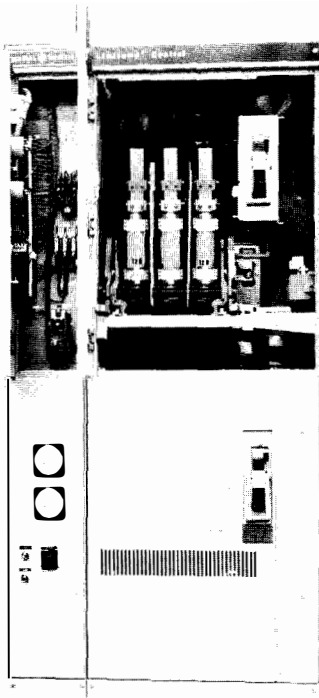

Fig. 63. Two-high enclosure with top high-voltage door open.

### Extra-width Enclosure

A special 42-inch-wide enclosure is available for terminating shielded cable with stress cones, or for terminating more than one large cable per phase. The enclosure design permits space for termination of two 750-mcm cables per phase with stress cones\* for motor and power leads. Figure 66 and Fig. 67 show the space available in this extra-width enclosure. Design is basically the same as the 34-inch-wide one-high, and all data and information in these Instructions applicable to the one-high design apply to the 42-inch-wide enclosure.

The 42-inch-wide enclosure is used on all Limitamp controllers with full-load amperes higher than 360.

### POWER CABLE TERMINATION

In any installation, the cable should be prepared for termination in accordance with the instructions of the cable manufacturer. However, the following general recommendations are given for proper cable termination in Limitamp equipment.

1. Pull in the cables in accordance with the panel outline diagram and position them for maximum clearance between phases, ground and other cable or wire runs. Refer to the APPENDIX of these Instructions for recommended location of incoming cables in a standard Limitamp Controller.

\*General Electric Termi-Kit® stress cones.

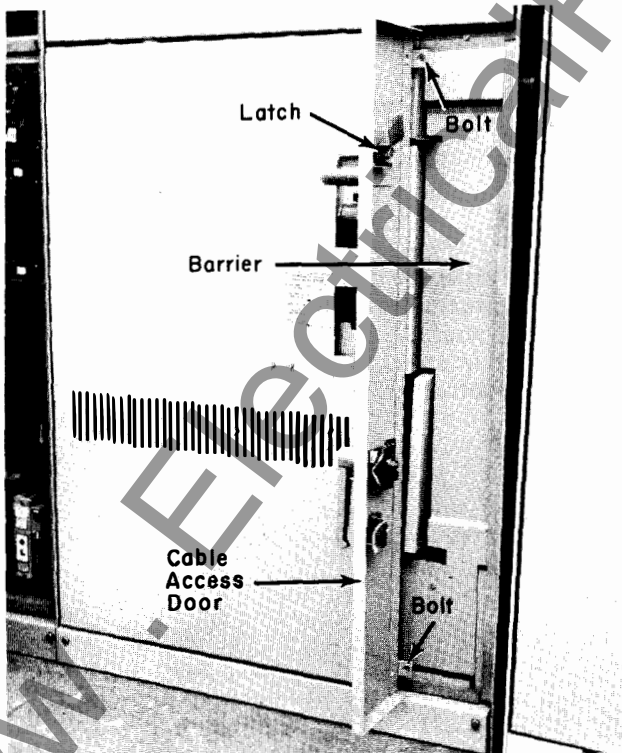

Fig. 64. Cable access door open on lower compartment, exposing barrier.



Fig. 65. Extra-width enclosure for motor cable.

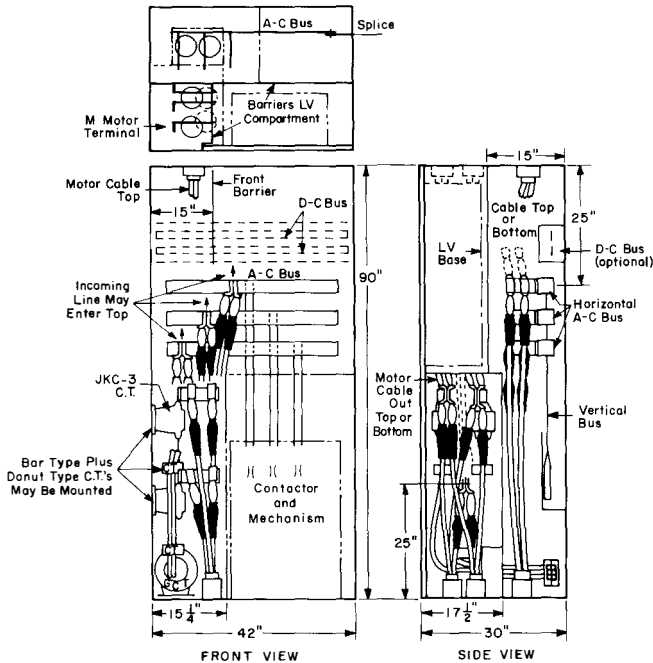

Fig. 66. Cable space available in 42-inch-wide enclosure.



Fig. 67. Motor cable terminations in 42-inch-wide one-high enclosures.

2. Prepare the cable for termination in accordance with the manufacturer's instructions. For suggested terminating methods, see pages 28, 29 and 30.

3. Bolt the cable terminals to the bus or other point of termination.

4. If contact between the cable and an adjacent bus cannot be avoided, as may be the case with the two 500-mcm cables per phase, tape the bus in the immediate vicinity of the cable contact point so that the surface creepage distance from the cable to the bare bus bar is at least three inches. Thus, the surface creepage from the bare bus where the cable terminates, to the bare part of the bus where the cable touches, will be at least seven inches. The thickness of tape on the bus should be approximately 5/32 inch. General Electric No. 8380 tape is recommended for most of the buildup, and General Electric No. 42005 Irrasil® tape is recommended over-all.

5. Where more than two 500-mcm cables per phase are required, they should be brought into different sections, or an incoming line compartment must be provided. If the two 500-mcm cables must be terminated with stress cones, a cable entrance compartment must be ordered.

6. Run all the low-voltage wires so as to avoid any possible contact with high-voltage lines.

#### Termination of Lead-covered Cable

Termination of lead-covered cable requires the use of potheads (see Fig. 68). The pothead manufacturer's instructions should be followed in terminating the cable at the pothead. Standard Limitamp starters have space for locating one pothead of the pull-through type which accommodates up to and including 2/0, three-conductor, 5000-volt cable. In this type of pothead, the three conductors of the cable are fanned out within the pothead and pass completely through it, with the pothead sealing and terminating the lead covering. For larger cables, potheads with terminating bushings are required.

In this case, or when more than one pull-through type is required, special cable entrance compartments are available.

Through-type potheads are satisfactory for varnished-cambric cable indoors. Paper-insulated cables are more hygroscopic and, since the only thing protecting the individual conductors from moisture is tape on the surface, high humidity might cause difficulty. Terminal-type potheads are required for paper-insulated cable.

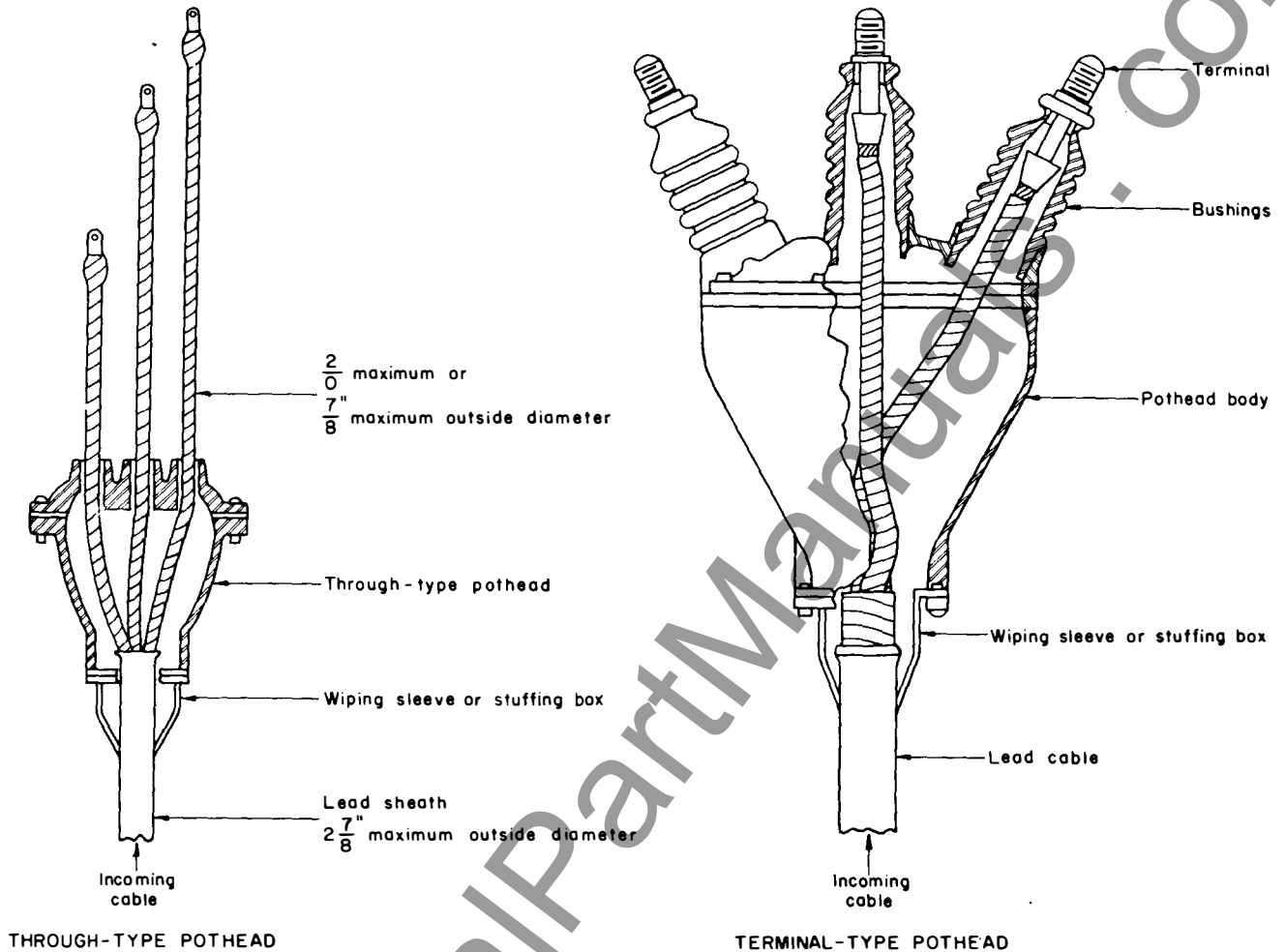

Fig. 68. Termination of cable in potheads.

### Termination of Pothead Cable

The instructions for terminating lead-covered cable by using potheads apply as well to those terminations of other types of cable where potheads may be desired.

### Termination of Non-shielded, Non-lead-covered Cable

This cable is generally run through rigid conduit or cable raceways and brought into the enclosure by the use of conventional cable clamps and conduit fittings. Refer to Fig. 69 and 70 for terminating details.

### Termination of Interlocked-armor Cable

Interlocked-armor cable is terminated by means of specially designed cable fittings. These termina-

tors consist generally of mounting bracket, armor clamp, and supporting base and bushing, with various modifications available for special types of sealing.

### Interlocked-armor, Non-shielded Cable

**RUBBER-COVERED** - Refer to Fig. 71 for general information concerning termination. For details, refer to Fig. 69. Note that rubber-covered cable requires only taping near the terminal and not back to the terminator fitting. However, if there is a possibility of oil coming in contact with the rubber insulation, it would be well to use a layer of Irrasil® No. 42005 tape all the way back to the terminator fitting.

**VARNISHED-CAMBRIC** - Refer to Fig. 71 for general information concerning termination. Note that varnished-cambric cable requires taping back to the terminator fitting, since the individual conductors or "singles" have no braid.

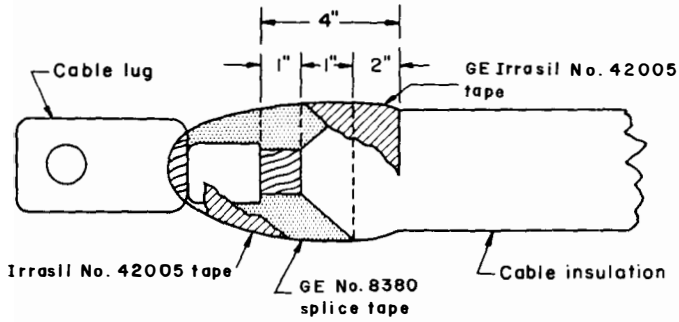
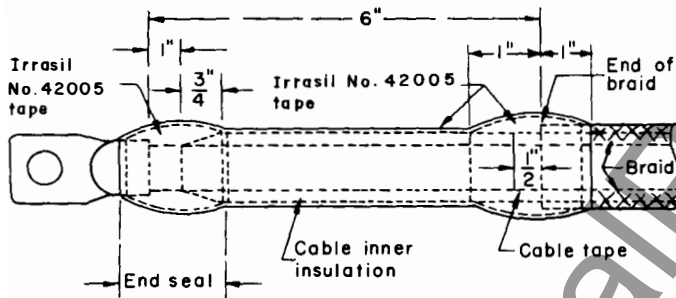

Fig. 69. Termination of rubber-insulated, non-shielded, non-lead-covered, 5000-volt cable.

**Interlocked-armor, Shielded Cable**

Interlocked-armor, rubber-covered, and varnished-cambric insulated cables are sometimes shielded at ratings of 5 kv and below. If they should be, proceed to terminate as detailed for other types of shielded cables.



1. Cut cable to proper length leaving conductor sufficiently long to extend into the terminal lug.
2. Remove braid, tape, and inner insulation and expose the conductor end for a distance of one inch plus the length of conductor to go into the terminal lug.
3. Attach terminal to conductor.
4. Taper the insulation as shown.
5. Remove the braid and tape, if any, six inches from the lug, exposing the insulation. Leave one-half inch of original cable tape extending beyond the cut-back braid.
6. Apply the end seal using GE Irrasil® electrical tape. Obtain a smooth wrapping but do not stretch tape more than necessary.
7. Bind down end of braid and tape, if any, with Irrasil tape as shown on drawing.
8. Apply two layers half-lap of Irrasil tape over all from lug to exposed braid.

Fig. 70. Termination of varnished-cambric-insulated, non-shielded, non-lead-covered, 5000-volt cable.

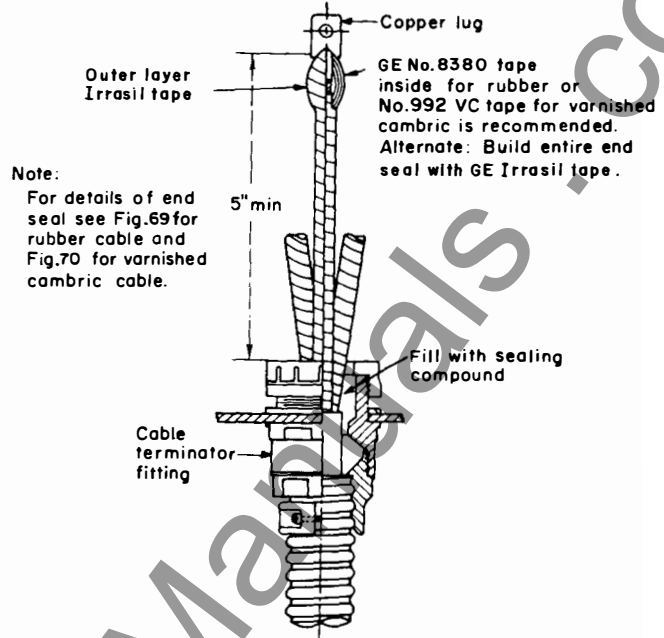

Fig. 71. Termination of interlocked-armor, non-shielded, 5000-volt cable.

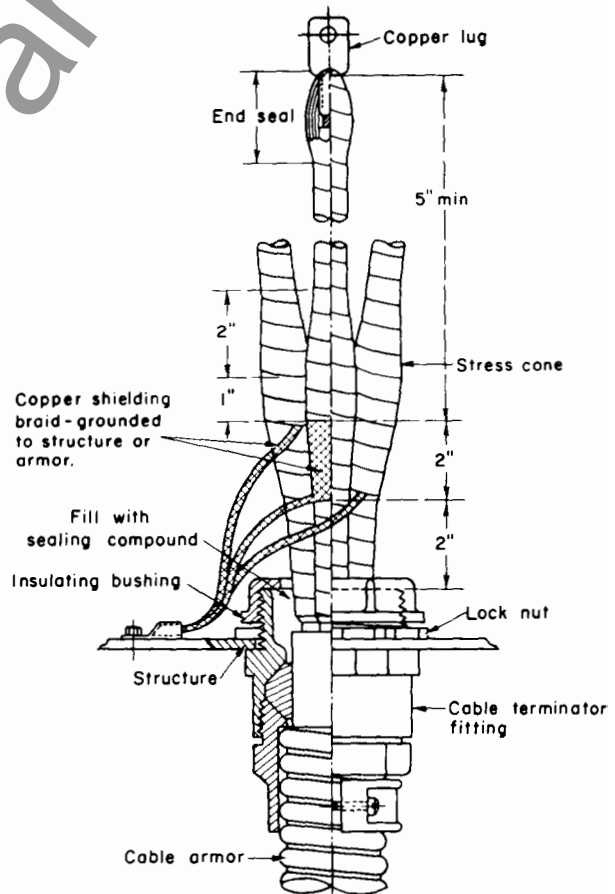

Fig. 72. Termination of interlocked-armor, shielded, 5000-volt cable.

**Termination of Shielded Cable**

It is recommended that when shielded cable is used, "stress-relief cones" be built up at the cable terminations, or else General Electric Termi-Matic® stress cones be used as shown in Fig. 74 and Fig. 75. This will relieve the electrical stress which occurs in the area around the termination of the ground shield. Whenever possible, the conduit should be brought in through the bottom. A maximum of one 500-mcm cable per phase may be terminated in one full-voltage starter section. When making shielded-cable terminations to Limitamp, the following procedure is recommended:

Use GE Termi-Matic system per Fig. 74, or else build stress cones with tape as follows:

1. Mark the cable at least 10 inches from the terminal point.
2. Remove all shielding from the terminal end to this point, leaving sufficient ground strip to reach the nearest ground connection.
3. Proceed to build stress cones as prescribed by the cable manufacturer. Refer to Fig. 72 and 73 for details.
4. Tie all of the ground strips together and fasten them to ground bus (if ordered) or to a large stud on the enclosing case. (See note on grounding under item on "Wire and Cable Entrance".)

If the foregoing recommendations, along with the cable manufacturer's recommendations, are followed, the cable terminations should be satisfactory and reliable. These instructions apply to both rubber-covered and varnished-cambric insulated shielded cables.

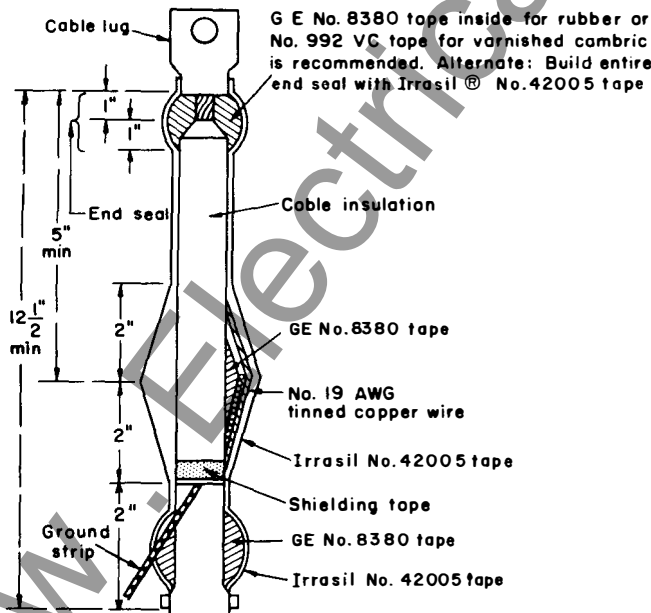

Fig. 73. Termination of shielded, 5000-volt cable showing stress-cone construction.

- 1 Maintains tight fit under load cycling and all cable operating conditions.
- 2 Track-proof insulating EPDM rubber.
- 3 Heavily-insulated shield edge protects high stress area of stress cone.
- 4 High conductivity semi-conducting rubber relieves electrical stress.
- 5 Internal step positions stress cone properly on cable shield.
- 6 Ground clamp provides positive ground.

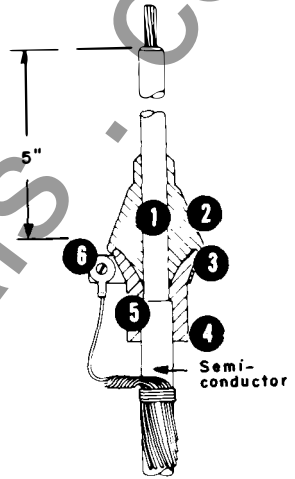

Fig. 74. TERMI-MATIC preformed stress cones (5 kV).

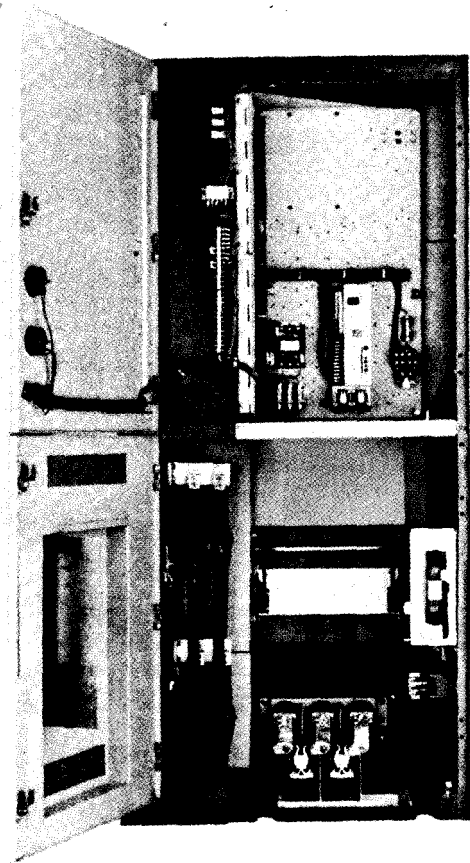
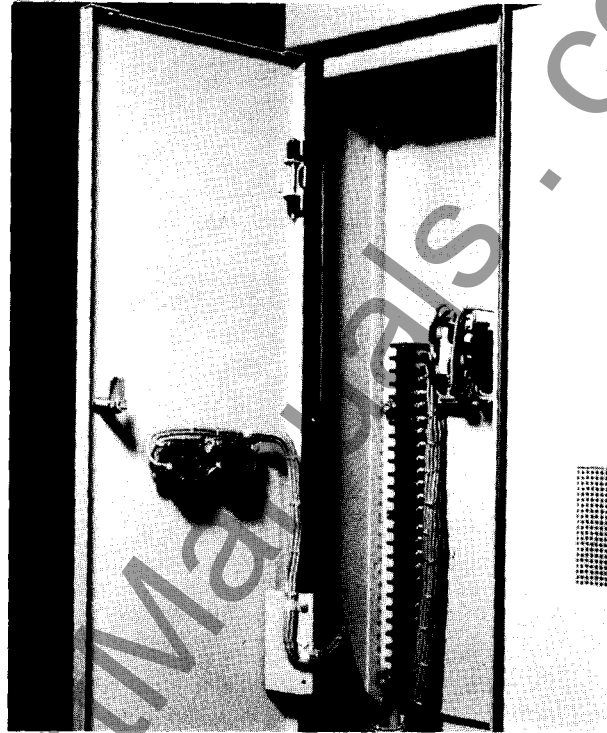

Fig. 75. 750-mcm cable terminated with Termi-Matic stress cones. For complete information refer to Bulletin IMF-126C.

**CONTROL CONNECTIONS**

Conduit for control wires should be brought in the areas as shown in the outlines. (See APPENDIX.) There is room in both the bottom and top for the control conduits to be brought into the enclosure. In the one-high, two-high, and three-high enclosures, the control connections are made through a terminal board in the low-voltage section as shown in Fig. 76 and Fig. 77.

The control wires coming up through the floor of the one-high enclosure should be run up to the upper low-voltage terminal board. There is a channel provided immediately behind the hinge of the lower door for the wires. See Fig. 78. Figure 79 shows the floor entrance area available for control conduit in the two-high and three-high enclosures. The wires coming out of these conduits should be run up the left-hand side of the enclosure directly behind the hinges of the low-voltage doors.



*Fig. 77. One of the three control terminal boards on the three-high enclosure.*

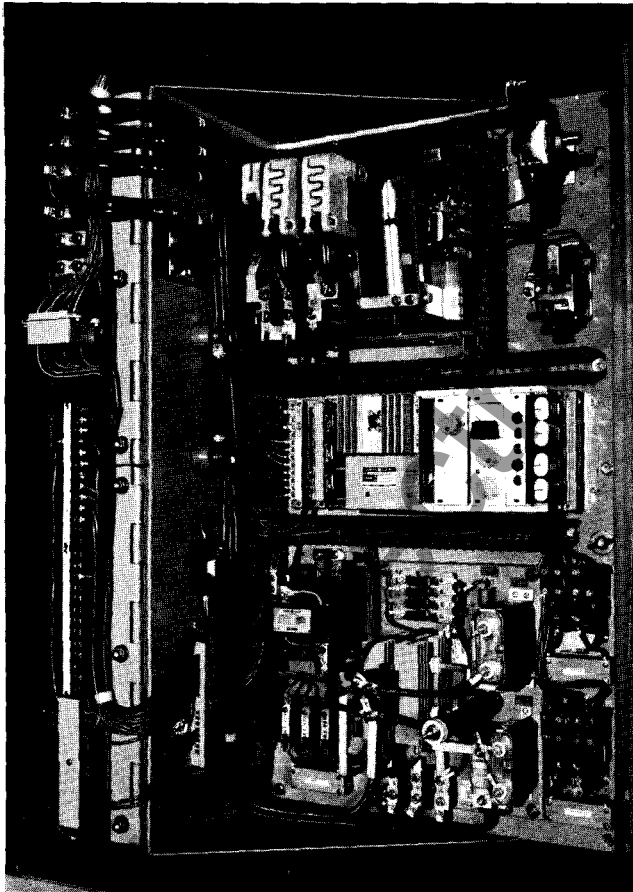

*Fig. 76. Control terminal board on one-high enclosure.*

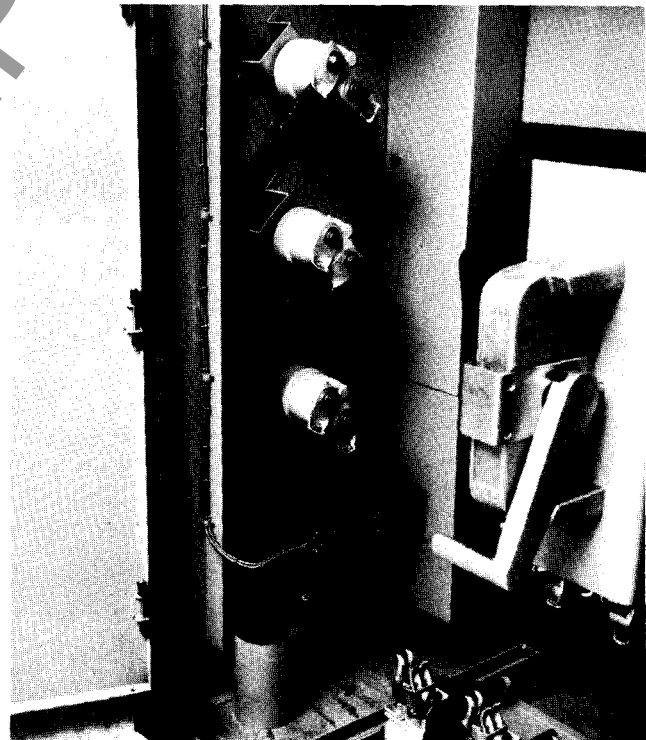

*Fig. 78. Motor terminal and channel for control wiring in bottom compartment of one-high 34-inch enclosure.*



Fig. 79. Floor area for control conduit in two- or three-high enclosure.

**REASSEMBLY — ONE-HIGH, TWO-HIGH, AND THREE-HIGH DESIGNS**

After all power and control-wire connections are made, the Limitamp controller should be reassembled by following the sequence on pages 11 thru 13, 14, and 17 in reverse order.

WHEN REPLACING CONTACTORS in enclosures, however, special attention is required to the following:

On one-high designs, roll the contactor onto the tracks by pushing on the contactor side hand grips. DO NOT PUSH ON THE ARC CHUTES. This would prevent proper seating, since the arc chutes must engage the isolator cam operator and swing partially upward as the contactor seats.

On two- and three-high designs, slide the contactor into the tracks and push on the lower cross-piece of the removable handle. Be sure that the contactor is slid far enough into the enclosure to allow replacement of the positioning bolt.



Fig. 80. Wing nut which holds swing base of one-high enclosure.



Fig. 81. Push contactor in enclosure by pushing on side frames.

*CAUTION: BE SURE ALL BARRIERS ARE REPLACED AND BOLTED TIGHTLY. INSTALL CONTACTOR POSITIONING BOLTS AND TIGHTEN. FAILURE TO PERFORM THESE OPERATIONS COULD RESULT IN FAILURE OF THE UNIT TO OPERATE SAFELY AND RELIABLY.*

**MECHANICAL OPERATION CHECK**

**All Power Off**

With the main incoming power turned off, the controller should be checked for closing and opening of the isolating switch. This can be accomplished by:

(Refer to Fig. 82.)

1. Push in the door-operated release (A) with your left hand. This is not a normal function, and should only be used for initial equipment checkout.

2. Push in the latch release (B) with the thumb of your right hand, and lift the handle (C) mechanism from the OFF to the ON position. The door-operated release can now be released. The contactor assembly should now be down and the stabs should be fully in place on the vertical bus.

3. Push in the latch release (B) and move the handle (C) mechanism from the ON to the OFF position.

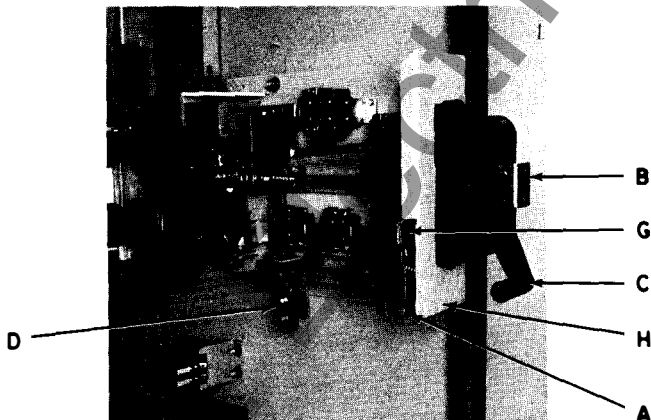

Fig. 82. Right-side of enclosure showing electrical interlock mounted on the enclosure.

The contactor should fully disconnect from the vertical bus and leave the fuses in the fully exposed position (E). The fuse-clip extensions (F) must contact all three ground-discharge fingers in this position.

4. Repeat steps 1 and 2 above until the contactor is reconnected to the vertical bus. Simulate the contactor being energized by pushing the dangle bar (D) forward (toward the rear of the enclosure). While holding the dangle bar forward, attempt to push in the latch release (B). The latch release should move only forward slightly, and the handle (C) should not rotate to the OFF position. With the dangle bar in the back position, push in the latch release (B); then attempt to push the dangle bar forward. It will move only forward slightly, but not enough to allow the contactor armature to close.

5. Repeat steps 1 and 2 above. When the handle (C) is rotated to the ON position, the door latch (G) should drop to within 1 1/2 to 1 3/4 inches from the bottom of the handle assembly (H).

6. If the mechanism fails to meet any of the above checks, DO NOT attempt to energize the controller! Call your General Electric Sales Office for corrective action.

7. Return all handles to the OFF position.

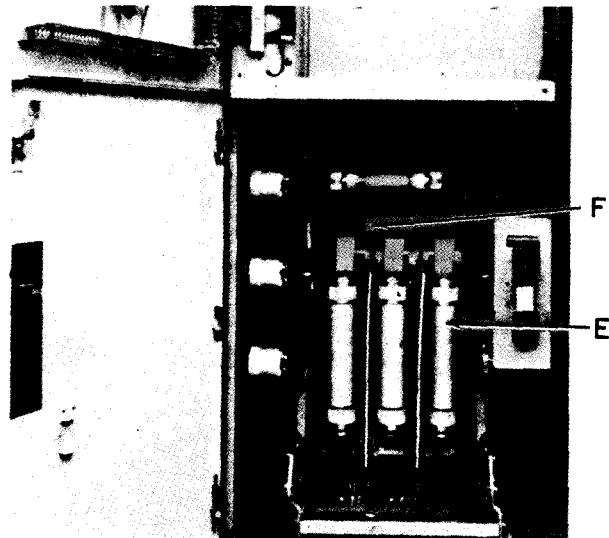

Fig. 83. Control-power transformers and fuses in one-high enclosures.

ASSEMBLY OF OUTDOOR ENCLOSURES

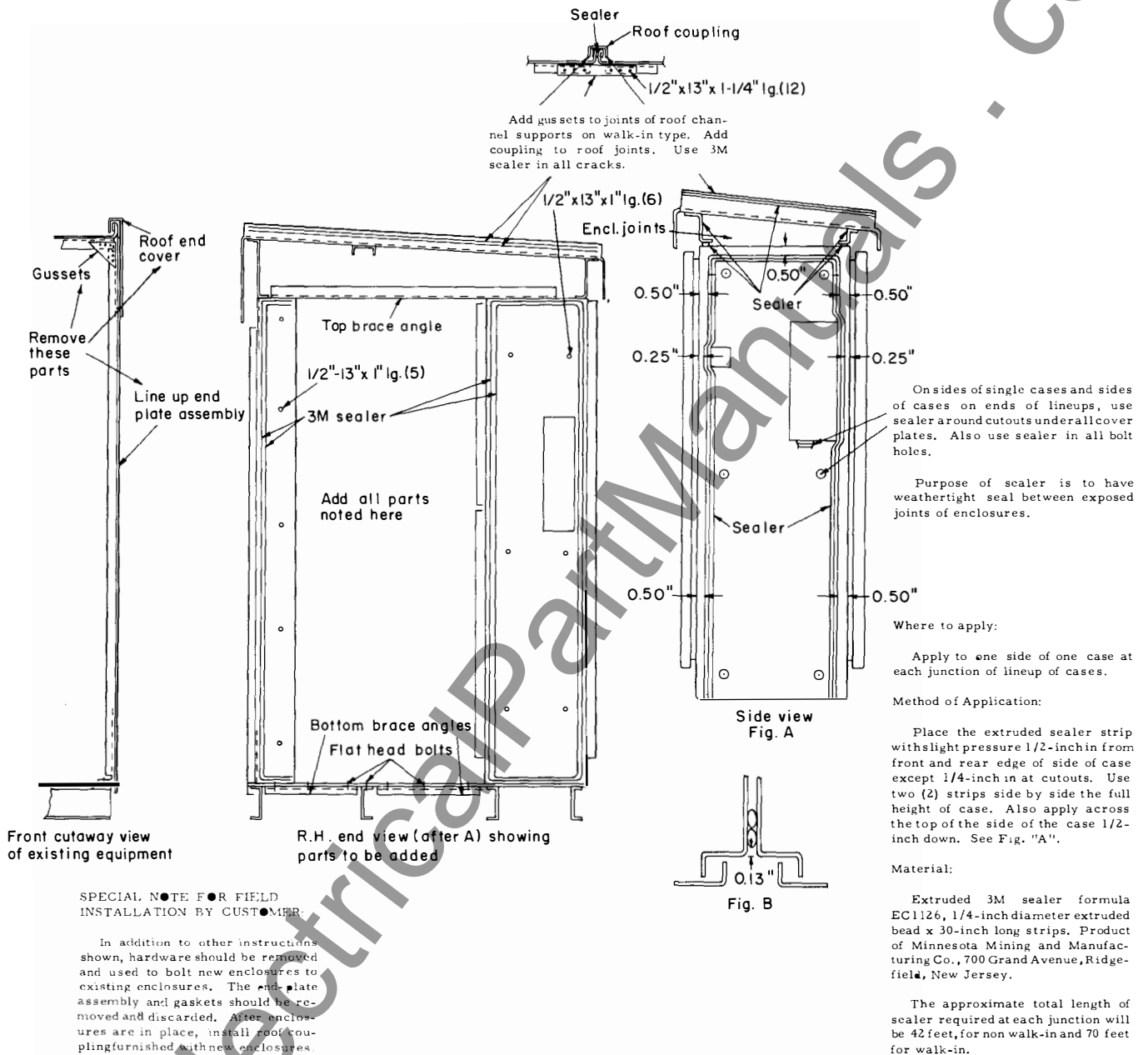

Fig. 84. Assembly of outdoor enclosure.

OPERATION

GENERAL

A test-power interlock circuit is provided to check out the control circuit of the complete unit without applying power to the motor. After all control-circuit connections are made, the controller should be put through its complete operating sequence, in the test position, as a final check.

A wiring diagram which shows the circuit and connections that apply to the controller is included

with the controller when it is shipped from the factory. All external wiring from the controller must be made in accordance with the connection diagram supplied with the controller.

TEST-POWER CIRCUIT

A complete operational check of the controller can be made without applying voltage to the motor or to the bus as follows:

1. The isolating-device handle must be in the open position. In the open position, contacts of the mechanically operated test-power interlock (Fig. 96, part #9) will open the secondary circuit of the control-power transformer, thereby isolating it. Other contacts of the test-power interlock will close the circuit to the test-power terminals on the control terminal board.

2. Refer to the elementary and connection diagrams for the required control voltage, frequency, and test-power terminal designations. Connect the required test-power to terminals provided on the terminal board in the low-voltage control compartment. Power is now applied to the low-voltage control circuit.

### PREPARATION OF CONTROLLER FOR OPERATION

Once the panel is in place and the cable terminated, clean the inside with a brush, soft cloth, or dry compressed air. Make certain that any dirt, dust or bits of packing material, which may interfere with successful operation of the panel devices, are removed from the panel.

*CAUTION: CARE SHOULD BE TAKEN DURING THE CLEANING OPERATION TO PREVENT ANY DIRT FROM BEING BLOWN INTO THE INACCESSIBLE SPACES OF THE DEVICES.*

Before the panel can be operated, even for a try-out without power, all devices must be placed in full operating condition. The armatures of many of the relays and contactors, including the high-voltage contactors, have been tied or blocked to prevent damage during shipment. All of these ties and blocks should be removed. Also, check to ascertain that no tools or loose wires have been left within the panel during installation.

The seating surfaces of unplated and laminated a-c contactor and relay magnets, as well as the ends of shafts, are coated with a heavy-grease rust preventative. Before operating the panel, the rust preventative should be wiped off and the magnet seating surfaces coated with a thin film of light machine oil.

Operate each device by hand to see that the moving parts operate freely and without binding. Make sure that all electrical contact tips are clean, free of grease and dirt, and make a good contact when closed. The relay and contactors are carefully adjusted at the factory; however, should an adjustment of these devices be necessary, these adjustments are explained in the individual instructions for each device.

After all connections have been properly made, all parts properly assembled, and all components thoroughly inspected and adjusted, the controller is ready for operation.

### NORMAL OPERATION

1. After all power and control connections are made, AND WITH THE ISOLATING DEVICE OPEN, megger between phases at the motor terminals, and between each phase and ground of the main bus, to ascertain that no short circuits are present. ♦

2. Close the compartment doors and apply power to the panel.

3. Close the isolating-device handle by moving the handle into the extreme upper position until it latches into position. Unless the latch (pusher) snaps out when the handle is moved to the extreme positions, either in the open or closed position, the contact marked CPI (control-power interlock) will not close.

If the operating handle of the isolating mechanism cannot be moved to the closed position, it may be the mechanical interlocking of the device that is preventing this movement. In order to move the handle to the closed position, the high-voltage door must be fully closed and the contactor must be open.

4. Operate the panel in the normal manner with the pilot devices (usually, push buttons) provided.

5. After the preliminary operation check is made, connect the motor and check for proper rotation.

### DOOR OPENING PROCEDURE

In order to open the high-voltage doors to gain access to the contactor or motor terminals, the contactor must be in the de-energized position. If the contactor is energized, the latch on the disconnect handle cannot be pushed in, the handle cannot be operated, nor can the door be opened.

Depressing the stop button de-energizes the contactor. The latch on the disconnect handle can then be depressed, which opens an electrical interlock in the secondary of the control-power transformer. When the latch has been depressed, the isolating switch handle may be moved to the lower or open position. With the disconnect handle in the lower position, the high-voltage door may be opened.

### Door-defeater Latch

IN CASE OF EMERGENCY, remove all power to the controller; then, the high-voltage doors may be opened with the contactor in the closed position and with the isolating switch closed, by using the hex-head bolts, located to the lower left of the isolating-switch handle, as follows:

**CAUTION: DO NOT PROCEED UNLESS ALL POWER TO THE CONTROLLER IS REMOVED. DOORS MUST NOT BE OPENED WITH THE POWER CONNECTED TO THE BUS.**

1. Turn the door latches 1/4 turn counterclockwise.
2. Remove the right-hand hex-head bolt, as shown in Fig. 85.
3. Turn the left-hand bolt 1/4 turn counterclockwise, as shown in Fig. 86. The door may then be opened.

**CAUTION: DEFEATING THE DOOR INTERLOCK LEAVES THE CONTROLLER CONNECTED TO THE BUS. THE BUS POWER SHOULD BE REMOVED.**

On some one-high enclosures, the low-voltage control panel serves as a barrier to isolate the high-voltage control-power transformer and fuses. An interference latch, shown in Fig. 87, prevents swinging this low-voltage panel out until the high-voltage door is opened.

Figure 88 shows the method by which the interference latch, which prevents rear access to the swing-out panel, can be released with the high-voltage door open.

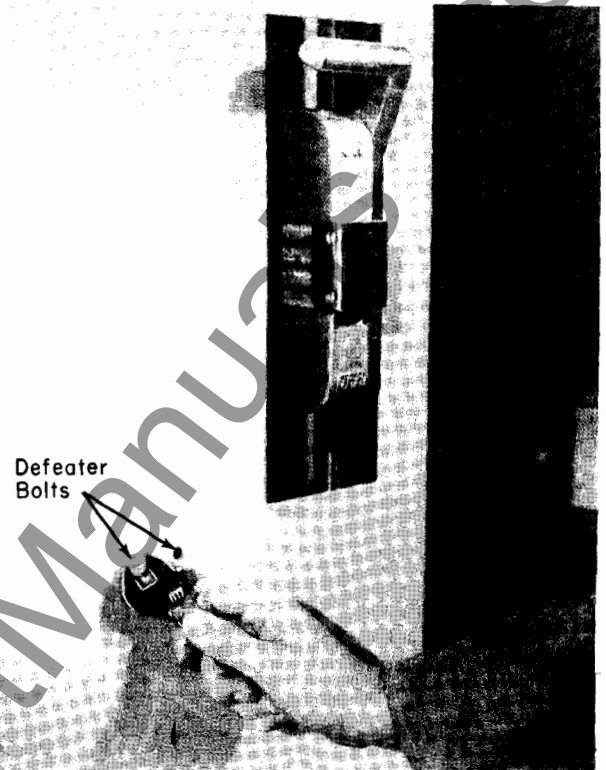

Fig. 86. Interlock defeater bolts.

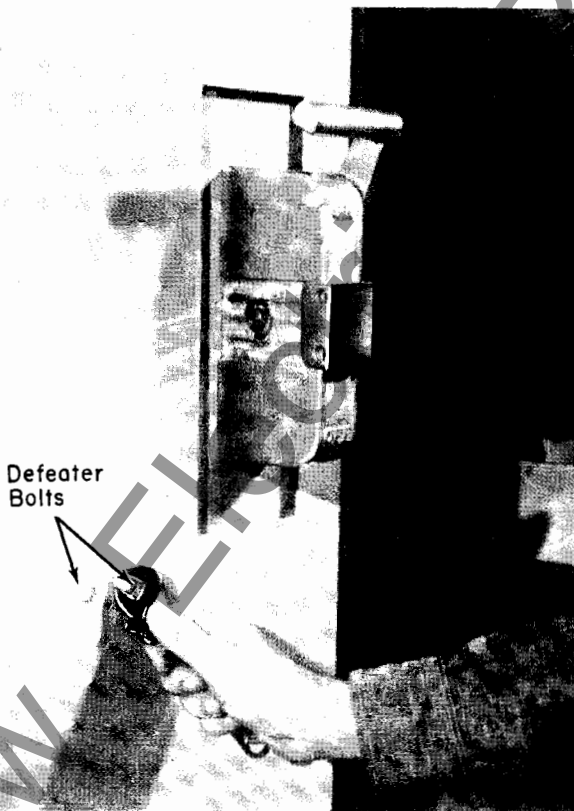

Fig. 85. Door interlock defeater bolts.

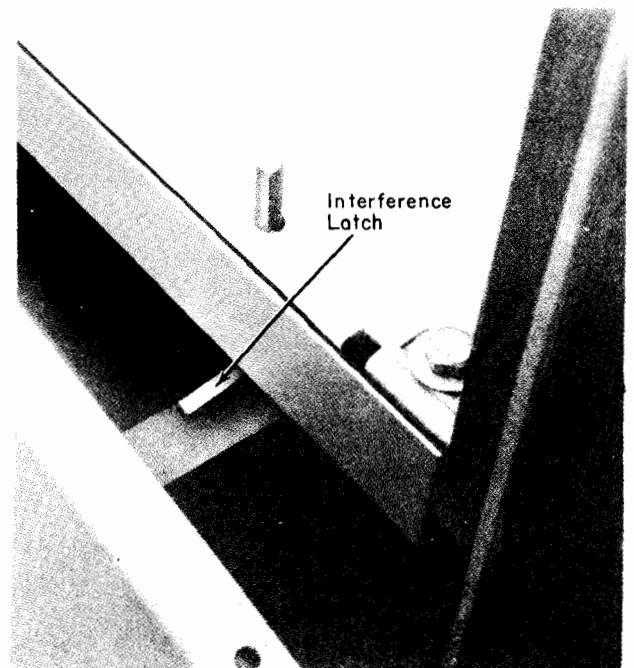

Fig. 87. Interference latch.

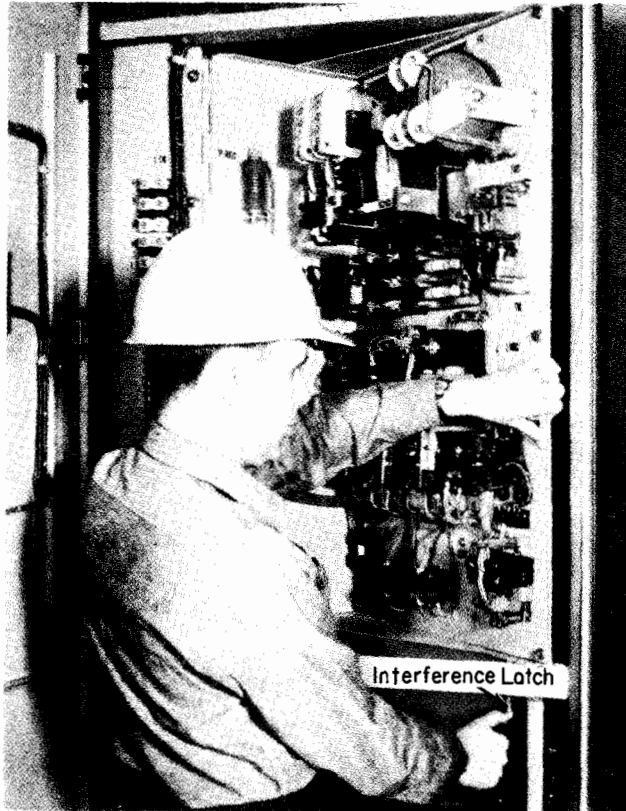

Fig. 88. Release of interference latch.

## INSPECTION, MAINTENANCE, AND SERVICING

### DRAWOUT CONTACTOR

Complete maintenance and adjustment instructions for the high-voltage contactors are presented in GEH-3102. Refer to that Instruction for all problems of servicing and adjusting; and to GEF-4337 for renewal parts.

Contactor tip life depends upon the severity of the service, but in any case, it is recommended that the tips be inspected every 100,000 operations. To inspect the contactor, move it out of the enclosure and swing it open as shown in Fig. 92. Check for loosened screws, nuts, bolts, clamps, etc. Check contact wear and force as outlined in GEH-3102.

### ISOLATING MECHANISM AND MECHANICAL INTERLOCK

**WARNING: UNDER NO CONDITION SHOULD THE SHUTTER BOX BE INSPECTED OR ADJUSTED WITH THE INCOMING LINE OR A-C BUS ENERGIZED.**

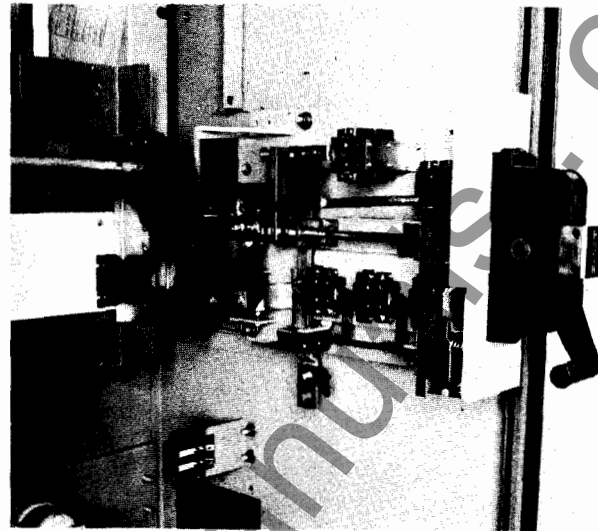
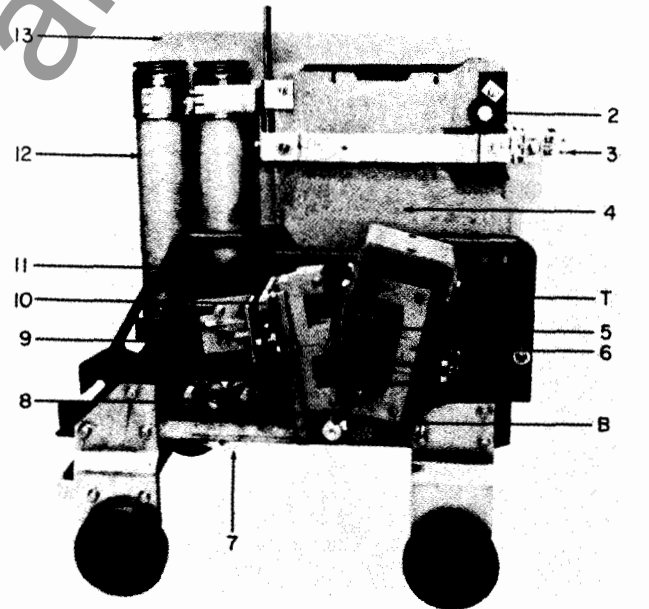

Fig. 89. Isolating mechanism and electrical interlocks mounted in enclosure.



- |                     |                                  |
|---------------------|----------------------------------|
| 2 Operating shaft   | 9 Armature stop                  |
| 3 Power disconnect  | 10 Electrical interlock operator |
| 4 Arc chute         | 11 Movable armature              |
| 5 Coil              | 12 Fuses                         |
| 6 Stationary magnet | 13 Interphase barrier            |
| 7 Intermediate stab |                                  |
| 8 Stub shaft        |                                  |

Fig. 90. IC2814E220 high-voltage contactor showing magnet and disconnect assembly.

The disconnect assembly is part of the contactor and is a complete unit containing arc chutes, power disconnects, power fuses, grounding straps, interphase barriers, and operating-shaft assemblies. (See Fig. 90.) This assembly is mounted on the contactor in such a manner that it can rotate. It can be rotated into positions shown in Fig. 91 for inspection or service of the contactor. When the contactor is pushed into its enclosure, the operating-shaft assemblies engage the isolation switch operating mechanism. (See Fig. 89.) Then, when the switch handle is pushed into the ON position, the disconnect assembly is rotated so that the power disconnects engage the vertical bus (Fig. 13).

Figure 93 shows a detailed picture of all components of the isolating mechanism, mechanical interlock mechanism, and contactor electrical interlocks. This is an integrated assembly with interrelated and interdependent functions and operations. The controller is shipped with this mechanism fully operational and properly adjusted, and with normal use, no maintenance should be required. If by some abnormal condition the mechanism is rendered ineffective, the following detailed checking procedure is recommended to ensure safe operation.

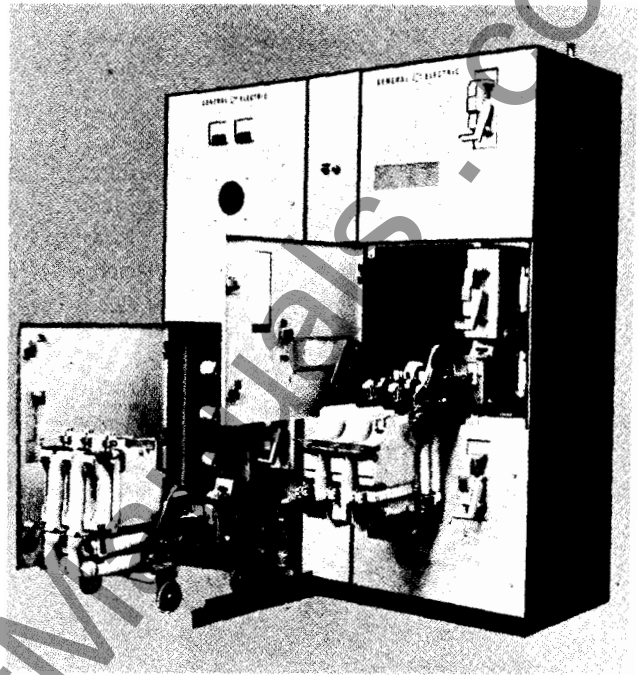

Fig. 91. One-high and three-high contactors in service position.

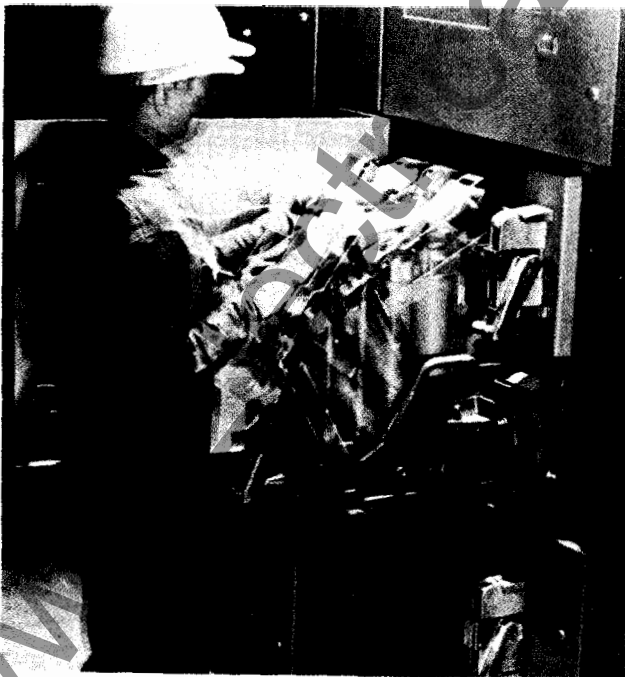
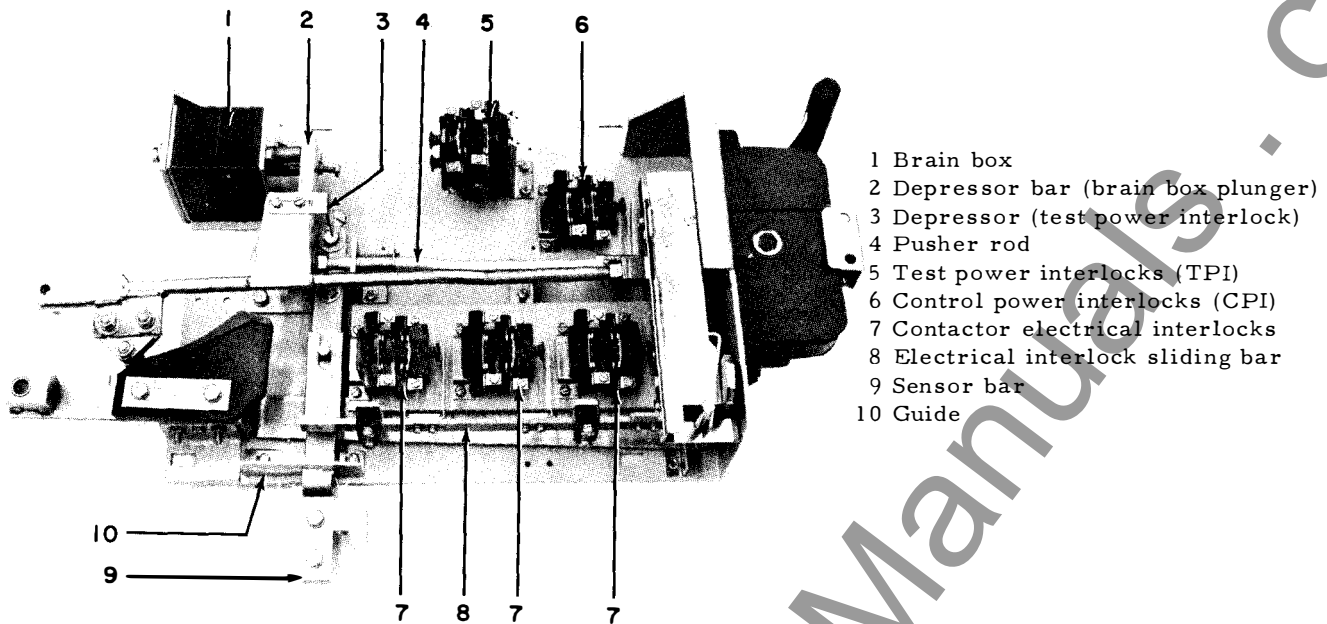

Fig. 92. Swinging high-voltage contactors open for inspection.



- 1 Brain box
- 2 Depressor bar (brain box plunger)
- 3 Depressor (test power interlock)
- 4 Pusher rod
- 5 Test power interlocks (TPI)
- 6 Control power interlocks (CPI)
- 7 Contactor electrical interlocks
- 8 Electrical interlock sliding bar
- 9 Sensor bar
- 10 Guide

Fig. 93. Manual isolator and mechanical interlock assembly.

CHECKING PROCEDURES – MECHANICAL INTERLOCK AND MANUAL ISOLATOR

1. Check door mechanical interlock for proper interference.

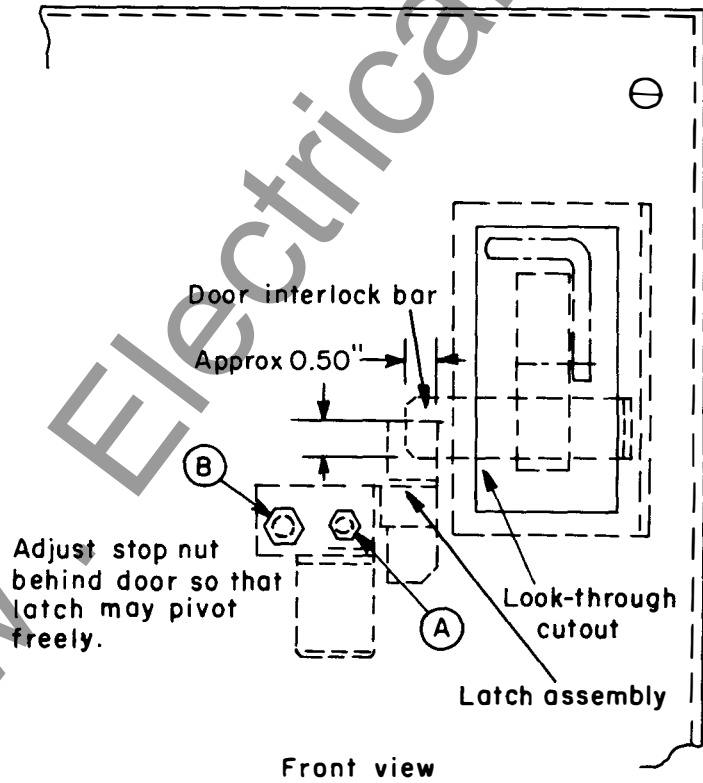

To check if sufficient (or safe) interlocking between door and door interlock bar exists, the following should be done:

- A. Open high-voltage door.
- B. Stab in contactor (handle closed). Manually depress door forgetter per Fig. 82 (A).
- C. Close door against interlock bar.
- D. Look through door cutout below handle and visually determine if there is approximately 0.50-inch overlap (see sketch).
- E. For final check close door, stab contactor and try to pull door open. Door should not open.

2. Check door interlock bar clearance and spring compression.

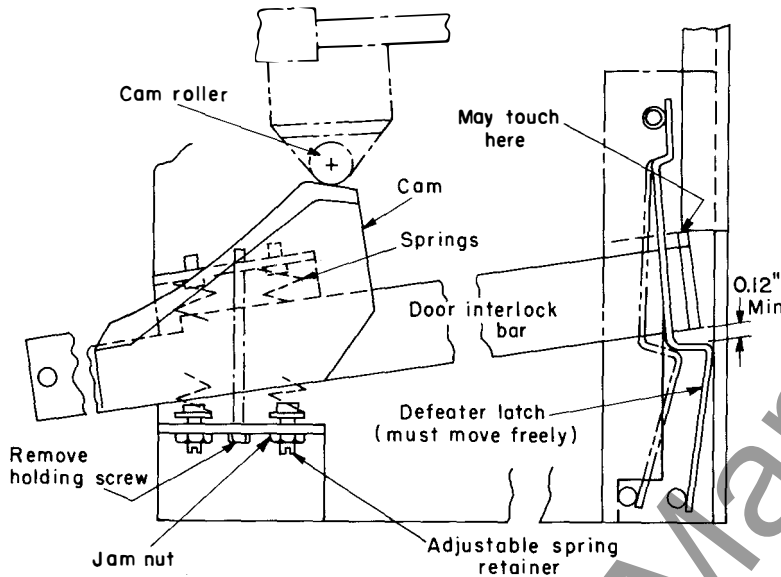

A final check can be made to assure proper operation of mechanism with high-voltage contactor in place. Remove holding screw. Contactor must be in disconnected position (handle OFF). In this position, the spring pressure must be sufficient to hold door interlock bar off the defeater latch as shown. Defeater latch must pivot freely.

NOTE: If this condition cannot be obtained, spring compression should be increased.

3. Check for proper stab connection and interlock sensor bar operation.

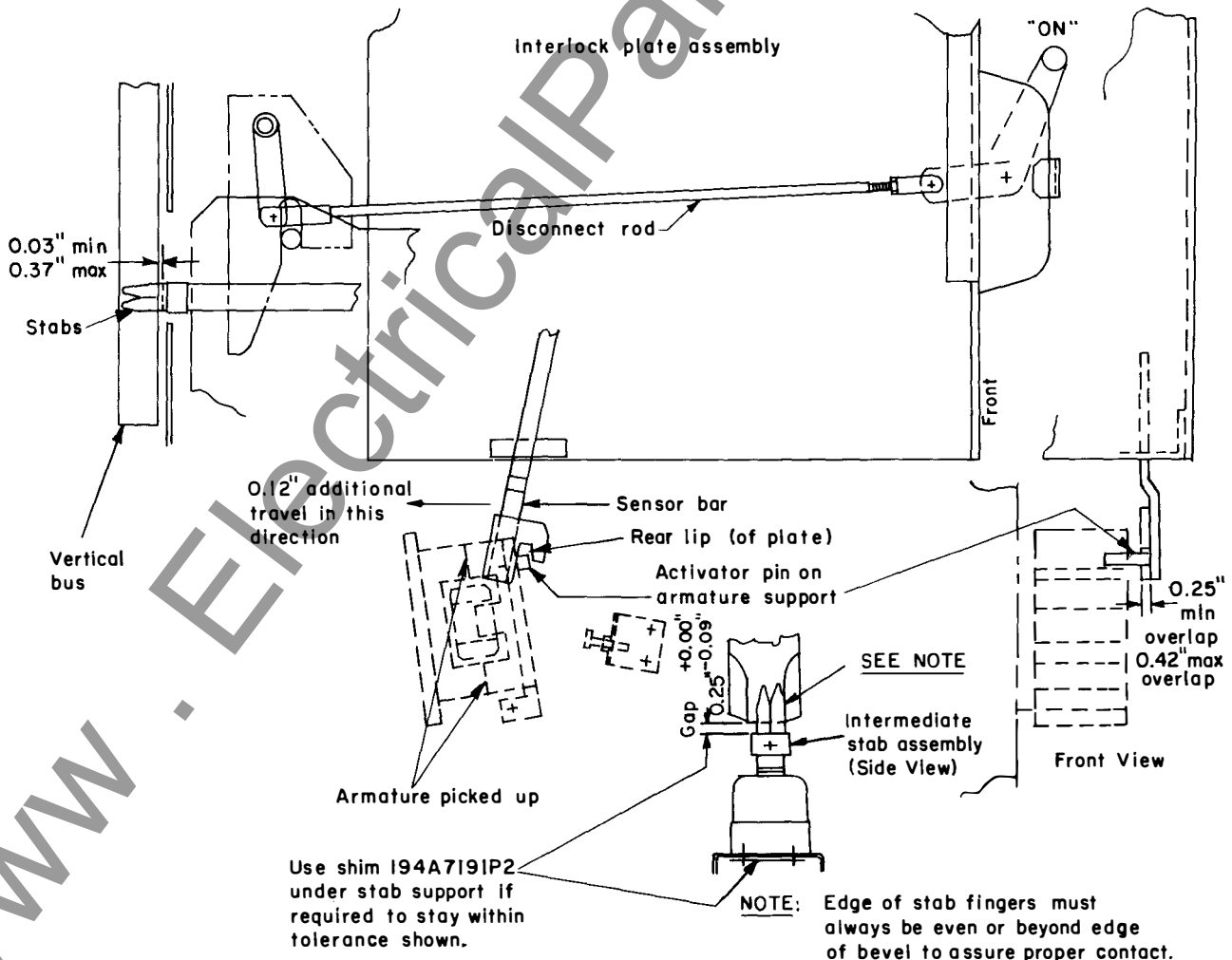

4. Check adjustment of pusher rod with brain box plunger.

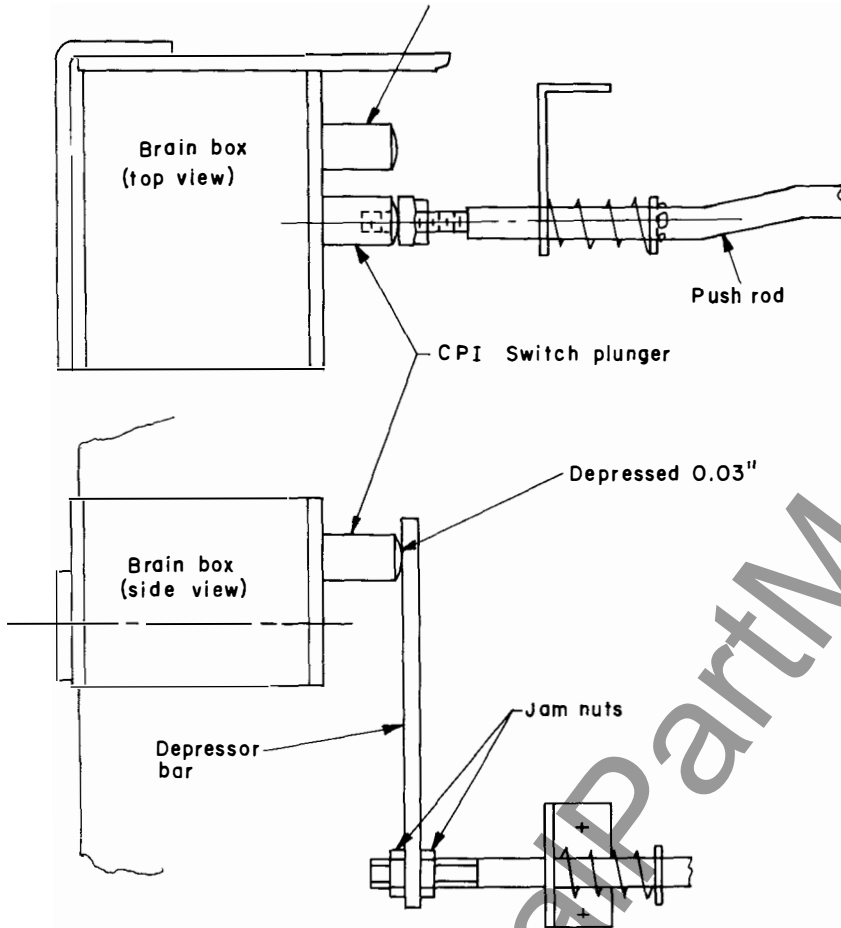

Dump Switch Adjusting – With handle in ON position and CPI switch plunger fully extended, adjust depressor bar to depress plunger 0.03-inch and lock into place with jam nuts.

After setting jam nuts, check again to make sure plunger is only slightly depressed and that contactor interlock plunger operates freely with no dragging or binding.

5. Check for proper operation of pusher rod and control power interlock operation.

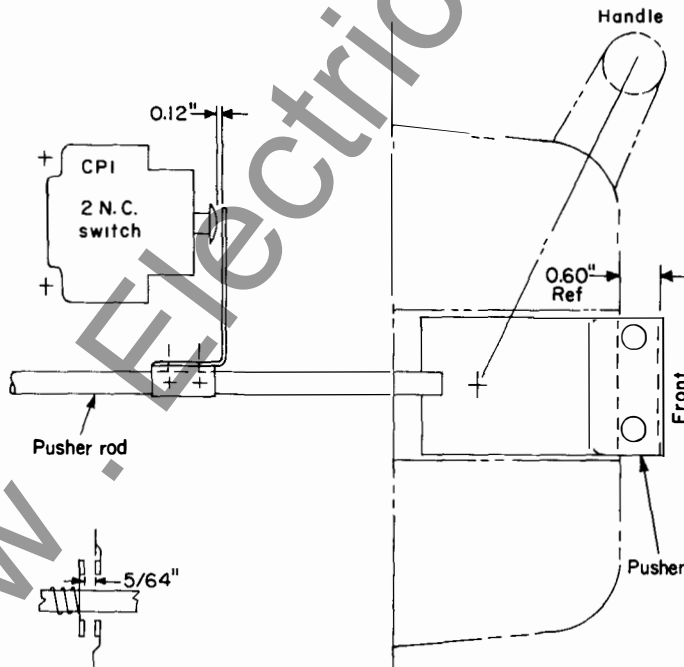

Set 0.12-inch gap (as shown) with push rod extended (Out position). See 0.60-inch reference.

Then, check the interlock operation with the switch rod depressed.

Both contacts must be open and have a contact gap of at least 5/64 inch.

6. Check test power interlock adjustment.

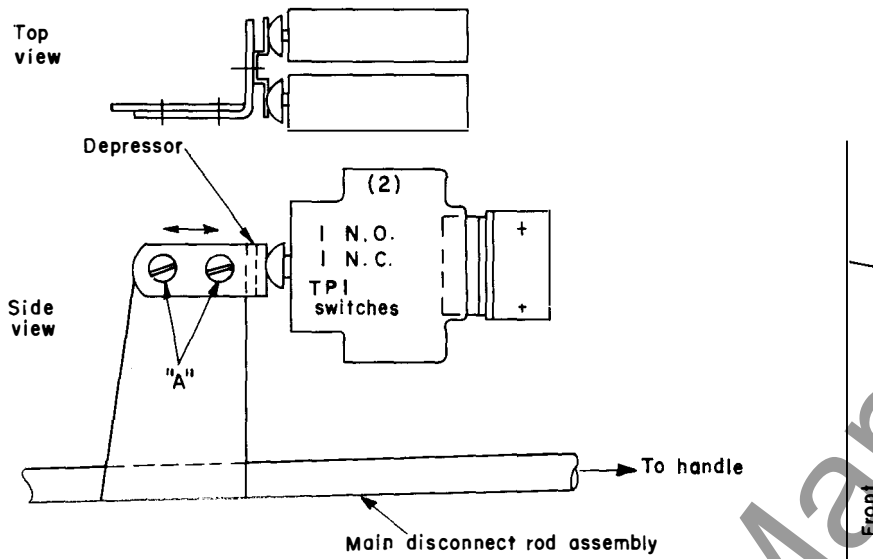

Adjust depressor bracket(s) by bending to depress interlock plungers equally with handle in OFF position.

Loosen screws "A", depress interlock plungers (2 or 3) all the way, then move depressor back 0.04 to 0.06 inch for slack and tighten screws.

7. Check adjustment of sensor bar with brain-box plunger.

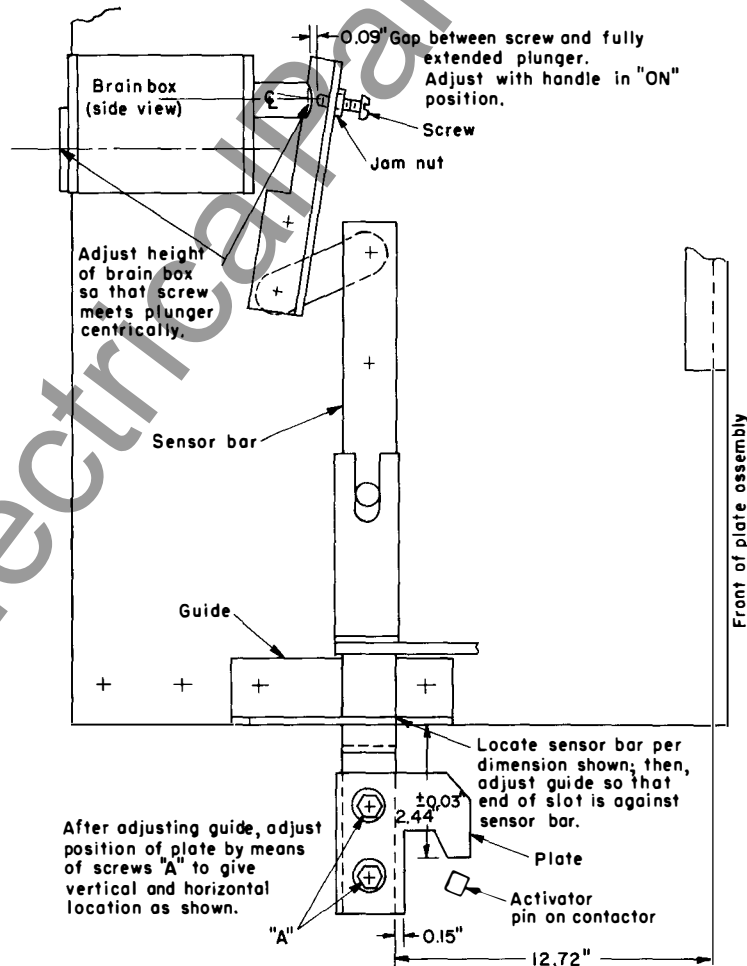

**ADJUSTMENT OF ELECTRICAL INTERLOCKS**

1. The engagement of the activator pin on the contactor armature support with the sensor bar should be such that an overlap of 0.25- to 0.42-inch exists. (See Fig. 94.)

2. To assure "free-closing" of the armature in connection with the sensor bar, a minimum of 0.12-inch of additional travel of sensor bar should exist when armature is fully picked up.

3. When the contactor drops out, check to ensure

that the spring-loaded sensor bar returns to its fully open position.

4. After the sensor bar has been properly located, adjust the gap between the interlock plungers and the depressor brackets. Slots are provided in the depressor bars to permit adjustment.

5. With the contactor armature in its fully closed or energized position, check all interlocks to see that the following tip gap and wipes are maintained:

- a. Normally closed tip gap: 5/64-inch minimum
- b. Normally open tip wipe: 3/64-inch minimum

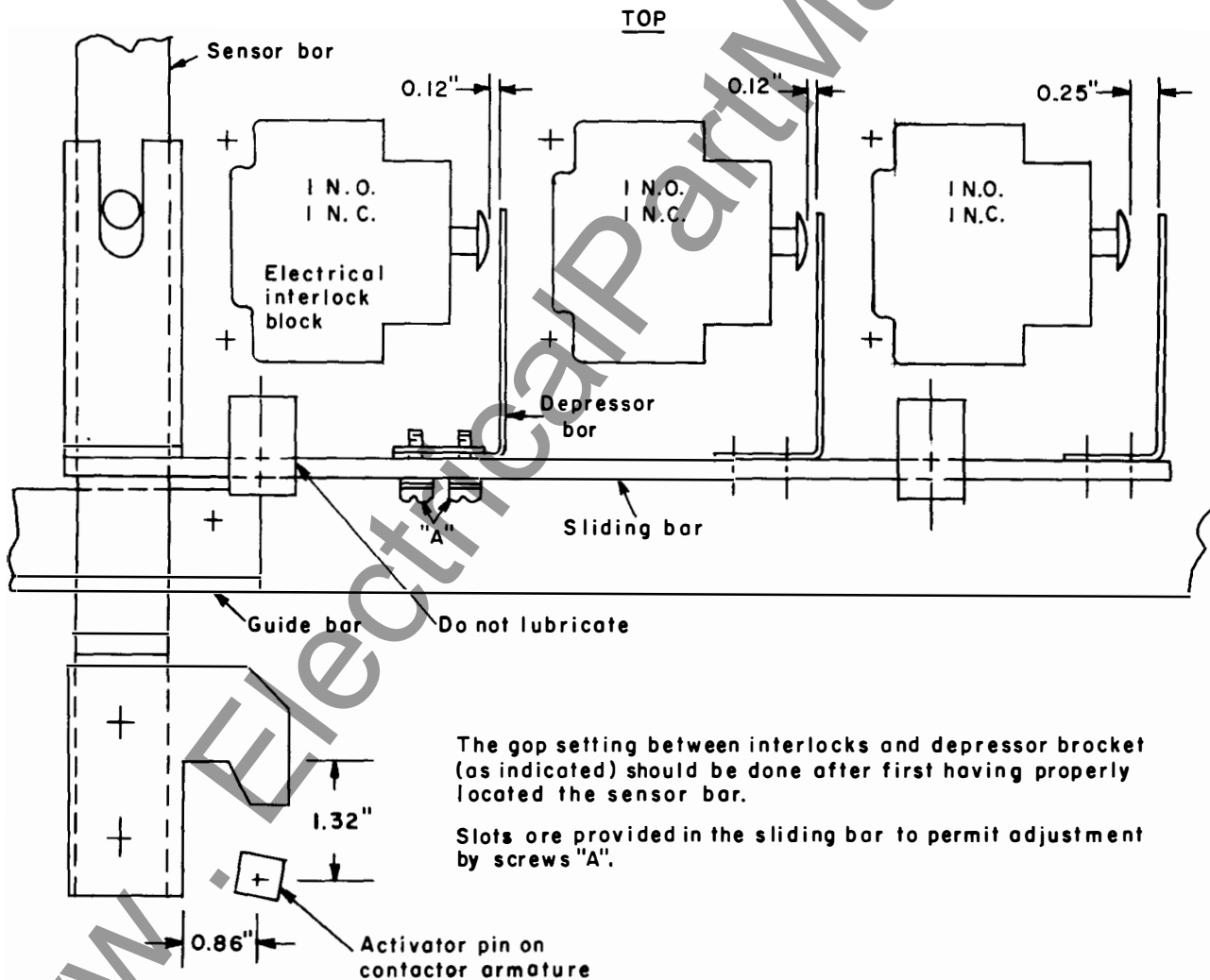

Fig. 94. Electrical interlocks.

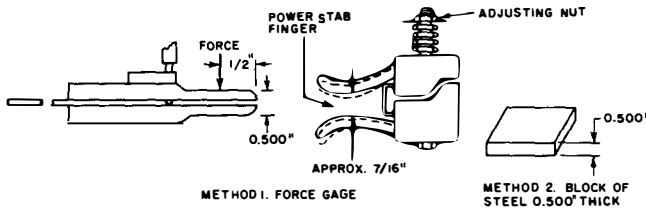

Fig. 95. Adjustment of force on power stabs.

## POWER STABS

All power stabs should be adjusted by using a force gage (Fig. 95). Each gage is calibrated by applying force one-half inch from the end and obtaining deflection of dial indicator for 45, 50, and 55 pounds. The dial face can be marked for these three loads. Tighten the adjusting nut until the force is  $50 \pm 5$  pounds. The adjusting nut is self-locking.

If a force gage is not available, an alternate method of adjusting may be used. Use a small block of steel exactly 0.500-inch thick. Place the block in the stab finger and tighten the adjusting nut until the block just moves in and out of the stab freely. With the block in the stab, note the present position of the adjusting nut, and turn two complete turns to the right. The adjusting nut is self-locking; therefore, it is locked in this position. Remove the block from the stab; the force of the stab is now adjusted properly, although not as accurately as with the force gage.

The dimension between the fingers is controlled by the retainer in the finger assembly. It should be approximately  $7/16$  inch. The finger assembly should be free to rock up and down  $\pm 1/8$  inch.

## PREVENTIVE MAINTENANCE GUIDE

Maximum trouble-free service from Limitamp controllers requires periodic inspection, preventive maintenance, and periodic cleaning. A definite schedule should be maintained for inspection, the frequency depending upon operating conditions. Preventive maintenance activity should then be established as the result of periodic inspection.

In these routine inspections, four basic categories of deteriorating influences should be kept in mind:

1a. The effect of foreign material: Dirt and dust from the environment such as wood fibers, coal dust, cement, lamp black, lint.

1b. The effect of chemicals in the atmosphere: such as sulfur dioxide, chlorine, some hydrocarbons and salt water.

2. Mechanical wear and fatigue on all moving parts.

3. Heat.

4. Loose joints and connections.

Follow directions in these Instructions for obtaining access to all sections of the controller including high-voltage door interlocking. Also, refer to GEH-3102 for directions relative to inspection of the high-voltage contactor.

The following are some specific recommendations:

1. Check for cleanliness generally, but particularly for accumulation of any foreign material on insulators. Voltage failures can result from tracking across insulation surfaces when they are dirty.

2. Check for abrasive material accumulated in the isolating mechanism and mechanical interlock bearing and cam surfaces.

3. Check for buildup of dust or dirt which would reduce any air or surface voltage clearances.

4. Excessive heat can reduce spring tension on stabs. Therefore, check stab tension per Fig. 95 once each year, or if there is evidence of heating.

5. Excessive heat can cause wire and cable insulation breakdown. Therefore, check for any evidence of melting, discoloring, deterioration of wire and cable.

6. Overheating can cause power fuse clips to lose tension. Evidence of clip heating and tension loss could be checked by referring to Fig. 10 of GEH-3102.

7. The isolating mechanism has a life expectancy of approximately 1000 operations. If the application is such that the mechanism is operated more than twice each day, then the mechanism should be checked at the end of each 1000 operations, otherwise a yearly inspection is recommended.

8. Periodic checks of dimensions of the isolating mechanism and mechanical interlocks is strongly recommended. Follow the section in these Instructions entitled "ISOLATING MECHANISM AND MECHANICAL INTERLOCK".

9. When any part of the isolating mechanism and mechanical interlock is replaced, all dimensions and checking procedures referred to under No. 8 above should be followed to be sure the system is in safe working order.

## GEH-3091C, IC7160 Limitamp® Controllers

### RENEWAL PARTS

For renewal parts of the contactor, refer to GEF-4337.

For controller parts that are part of the enclosure, refer to Figs. 96 thru 99, and the Parts List associated with these figures.

When ordering renewal parts, address the nearest General Electric Company Sales Office, specify the quantity required, and give the catalog number or describe the required parts in detail. Give the complete nameplate rating of the equipment.

#### CONTROLLER PARTS LIST

Part No.	Total Qty	Description	Catalog No.	Part No.	Total Qty	Description	Catalog No.
1	1	Handle*	149B1746G1	14	14	Bus and Terminal Insulator*	218A6831P1
2	1	Housing*	149B1759G1				
3		Contactor Operator		15	1	Two- and Three-high Motor-Stab Assembly	116C9929G1
	1	Right Hand*	149B1749G1				
	1	Left Hand*	149B1749G2	16	1	Two- and Three-high Coil-Contact Assembly	194A6912G1
4		Shutter Operator					
	1	Right Hand*	149B1768G1				
	1	Left Hand*	149B1768G2	17	1	Bottom Bus Insulation	116C9921P4
5 & 6	1	Shutter Assembly*	149B1752G1	18	1	Middle Bus Insulation	116C9921P3
7	1	One-high Coil Contact Assembly	194A6909G1	19	1	Top Bus Insulation	116C9921P2
				20	1	Blank Bus Insulation	116C9921P1
8	3	Contactor Interlocks (M)*	723B245G273	21	1	Top Bus Insulation	116C9921P7
9	2	Test Power Interlocks (TPI)*	723B245G275	22	1	Middle Bus Insulation	194B6318P1
10	1	Control Power Interlocks (CPI)*	723B245G274	--	1	Bottom Bus Insulation	116C9921P4
11	1	Handle and Interlock Assembly*	116C9928G1	23	1	Contactor Lift (For two- and three-high assembly)	116C9939G2
12	5	Stab and Insulator Assembly	149B1744G1				
13	1	One-high Bus Insulator	116C9921P5				

\*Part and Catalog Numbers are the same in both the one-high, two-high and three-high units.

NOTE: For renewal parts on the contactor, see GEF-4337.

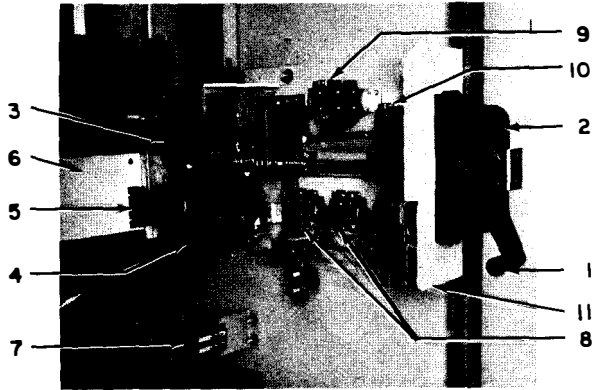

Fig. 96. Isolating switch, electrical interlocks and shutter mechanism in one-high enclosure.

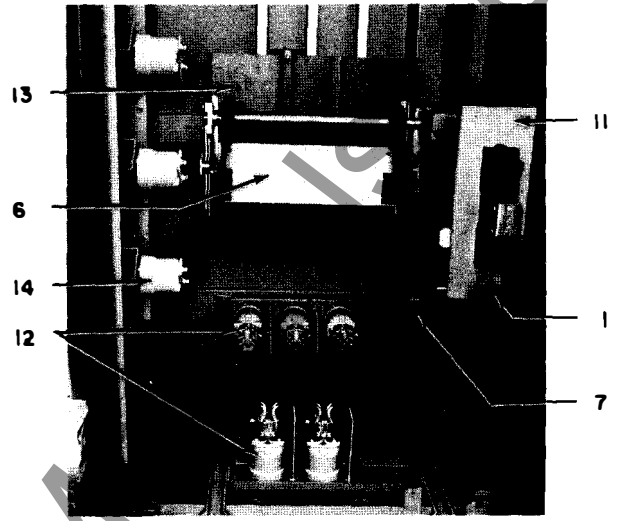

Fig. 98. Motor, stabs, and bus insulation in one-high enclosure.

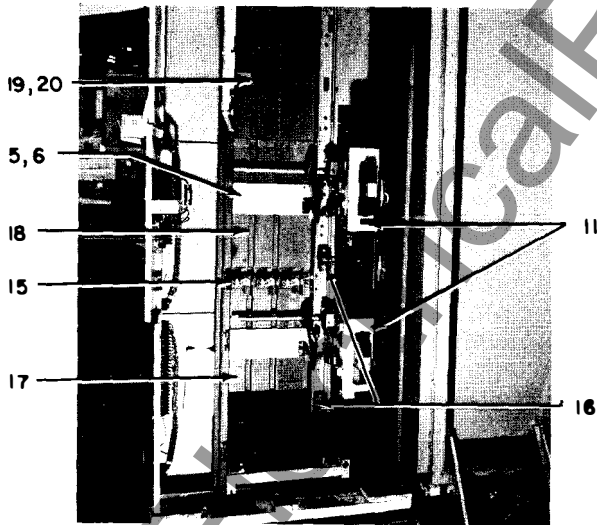

Fig. 97. Motor, stabs, and bus insulation in three-high enclosure.

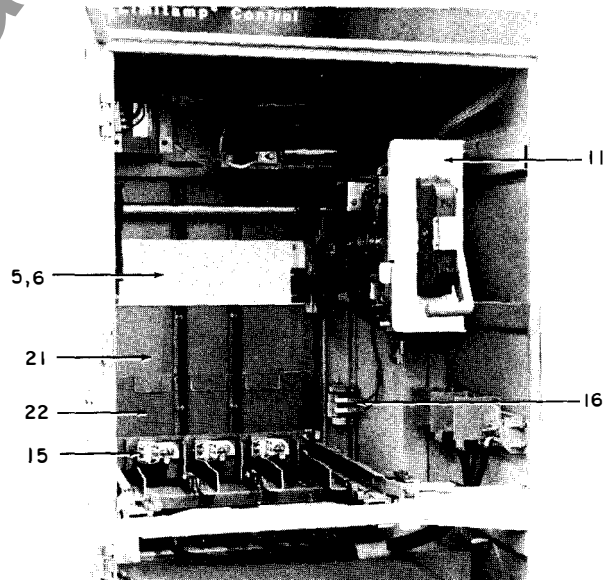
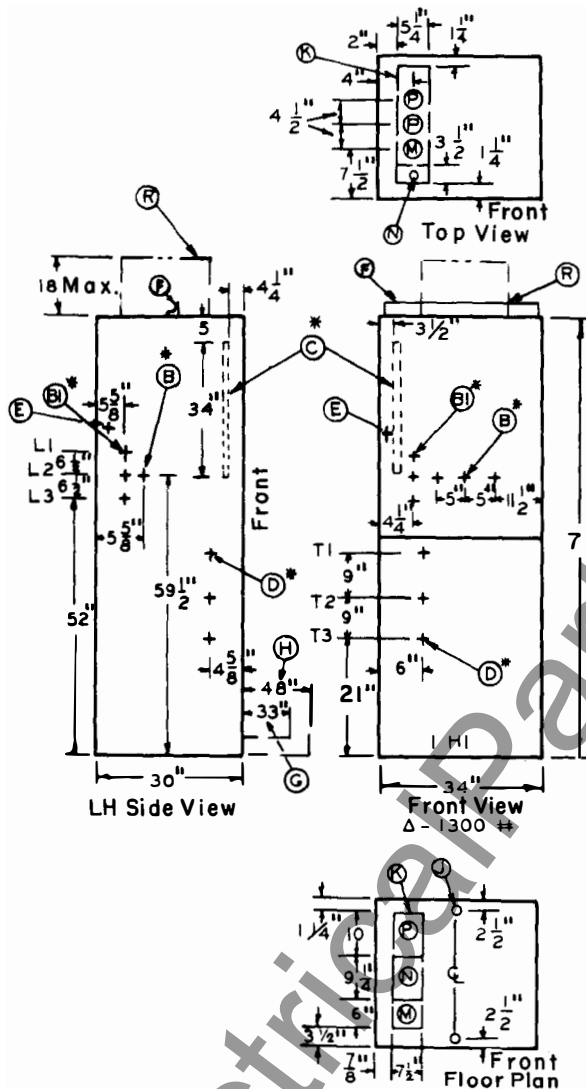

Fig. 99. Base insulation and contactor lift for two- and three-high enclosure.

**APPENDIX**

**TYPICAL DIMENSIONS — NEMA 1 AND 1A ONLY**

	Page
Dimensions, One-high Enclosures .....	47
Dimensions, Two-high Enclosures .....	48
Dimensions, Three-high Enclosures .....	49
Dimensions, One-high Design, Extra-width Enclosures.....	50
Dimensions, Auxiliary Enclosures.....	51



NOTES:

- B - Incoming-power terminal connection (if no bus ordered)
- B1 - A-c power bus (if ordered)
- C - Control-lead terminal board
- D - Motor-lead terminal connection
- E - Ground-bus terminal connection (if ordered)
- F - 4-inch removable lifting angle
- G - Space required to open door 90 degrees
- H - Aisle for contactor removal
- J - Mounting holes for 1/2-inch diameter anchor bolts
- K - Space available for incoming conduit
- M - Recommended position for incoming motor conduit
- N - Recommended position for incoming control conduit
- P - Recommended position for incoming power conduit
- R - Field discharge resistor shipped separate (if used)
- \* - Indicates terminal location - approximate for cable length
- All dimensions under 6 feet are in inches
- Δ - Approximate uncrated weight
- Add 5 percent for domestic shipping weight
- Add 20 percent for export shipping weight

Fig. 100. Dimensions, one-high enclosure. (360 amperes and below)

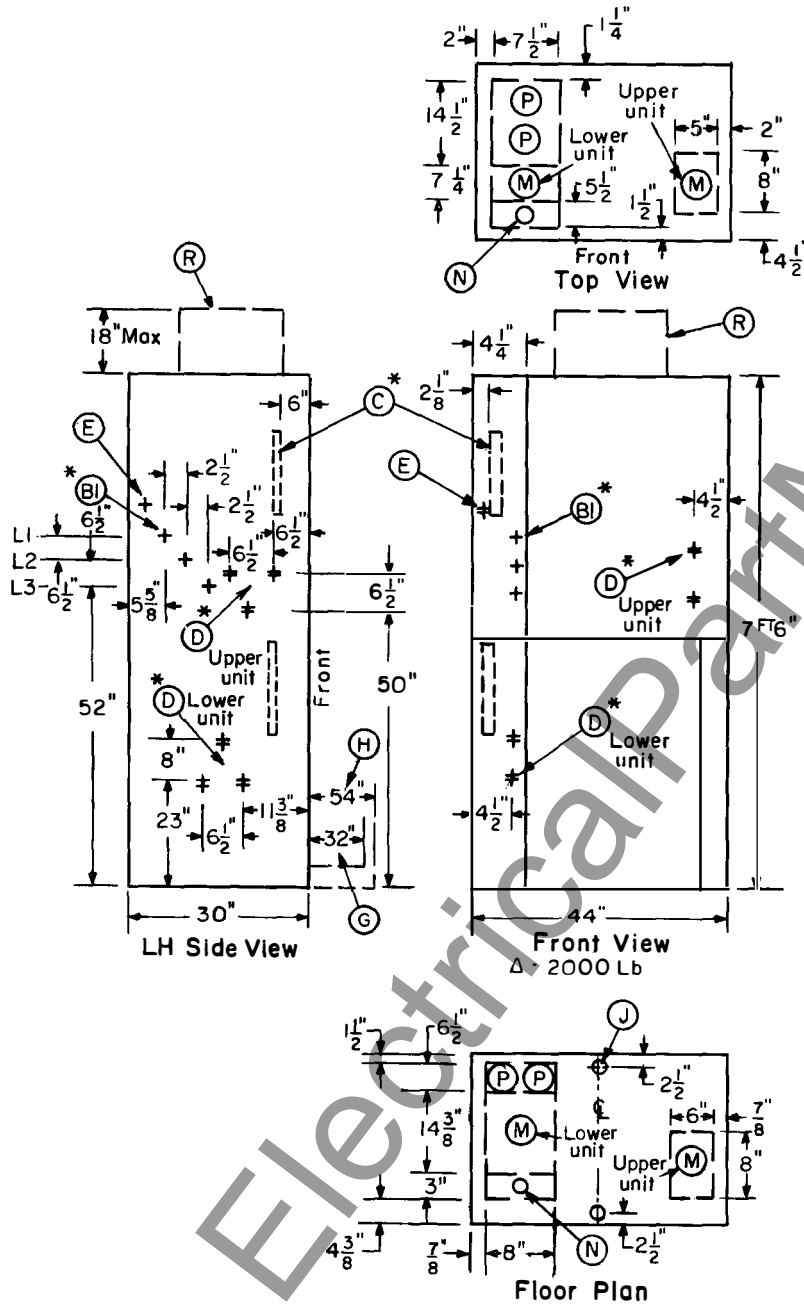

NOTES:

- B1 - A-c power bus (if ordered)
- C - Control-lead terminal board
- D - Motor-lead terminal connection
- E - Ground-bus terminal connection (if ordered)
- G - Space required to open doors 90 degrees
- H - 4-foot aisle for contactor removal
- J - Mounting holes for 1/2-inch diameter anchor bolts
- K - Space available for incoming conduit
- M - Recommended position for incoming motor conduit
- N - Recommended position for incoming control conduit
- P - Recommended position for incoming power conduit
- Q - Recommended position for incoming conduit
- R - Field discharge resistor shipped separate (if used)
- \* - Indicates terminal location - approximate for cable length
- Δ - Approximate uncrated weight
  - Add 5 percent for domestic shipping weight
  - Add 20 percent for export shipping weight

Fig. 101. Dimensions, two-high enclosure. (360 amperes and below)

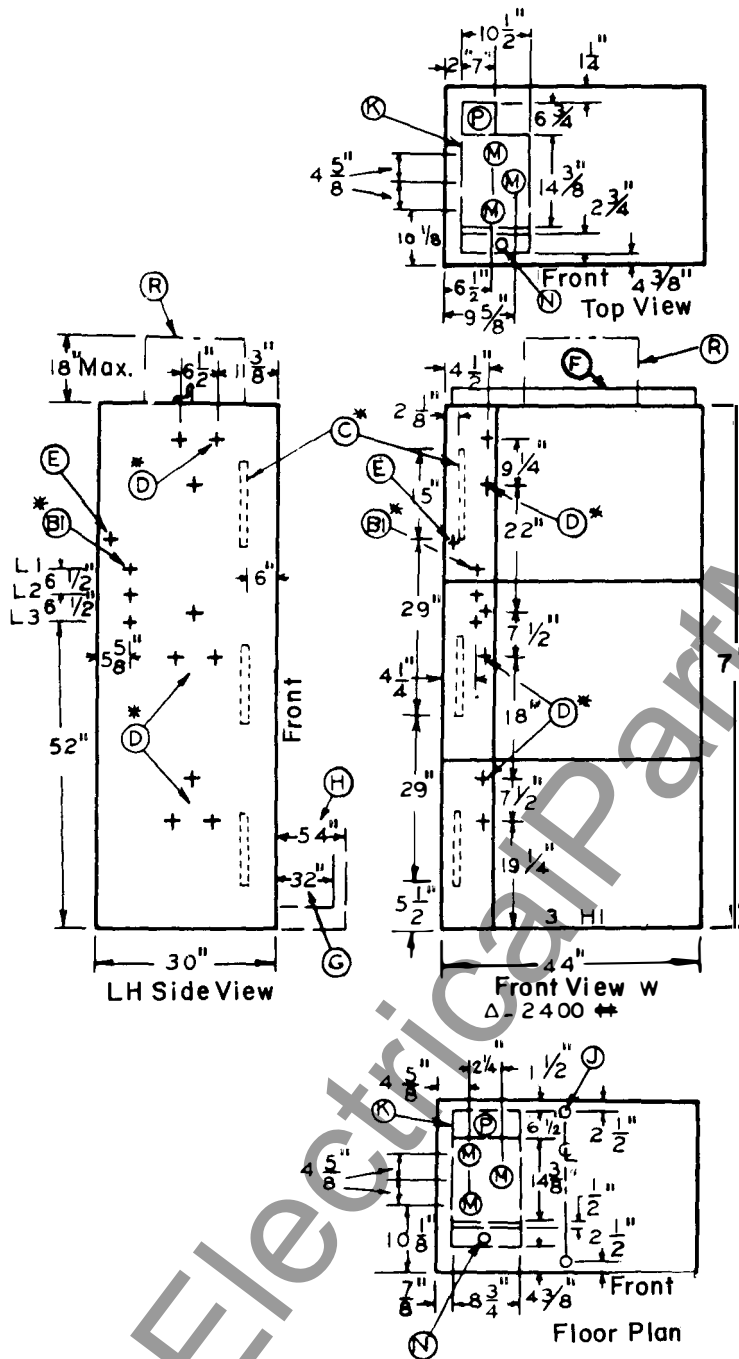

NOTES:

- B1 - A-c power bus (if ordered)
- C - Control-lead terminal board
- D - Motor-lead terminal connection
- E - Ground-bus terminal connection (if ordered)
- F - 4-inch removable lifting angle
- G - Space required to open door 90 degrees
- H - Aisle for contactor removal
- J - Mounting holes for 1/2-inch diameter anchor bolts
- K - Space available for incoming conduit
- M - Recommended position for incoming motor conduit
- N - Recommended position for incoming control conduit
- P - Recommended position for incoming power conduit
- R - Field discharge resistor shipped separate (if used)
- \* - Indicates terminal location - approximate for cable length
- All dimensions under 6 feet are in inches
- Δ - Approximate uncrated weight
- Add 5 percent for domestic shipping weight
- Add 20 percent for export shipping weight

Fig. 102. Dimensions, three-high (View B) enclosure. (360 amperes and below)



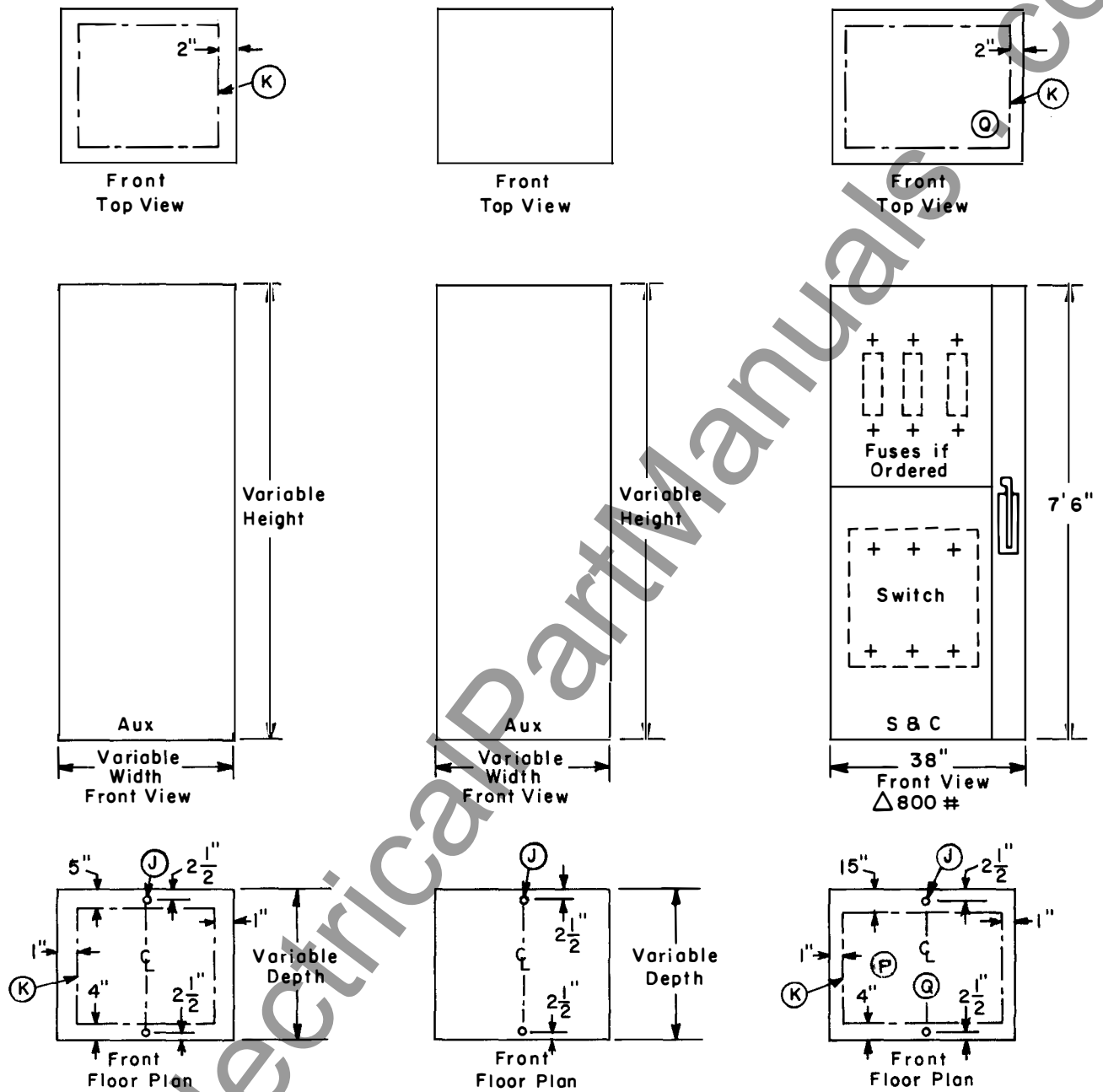

NOTES:

- J - Mounting holes for 1/2-inch diameter anchor bolts
- K - Space available for incoming conduit
- P - Recommended position for incoming conduit

- Q - Recommended position for incoming conduit
- Δ - Approximate uncrated weight
  - Add 5 percent for domestic shipping weight
  - Add 20 percent for export shipping weight

Fig. 104. Auxiliary enclosures.

www.ElectricalPartManuals.com



Outside the U.S. and Canada write Export Sales and Trading,  
570 Lexington Avenue, New York, NY 10022

GEH-3091C 1-85 (3M)

---

For further information  
call or write your local  
General Electric  
Sales Office or

General Electric Company  
General Purpose  
Control Department  
P.O. Box 489  
Mebane, N.C. 27302

---

**GENERAL**  **ELECTRIC**

Printed in USA