



CR194 Two-High Vacuum Limitamp® Control

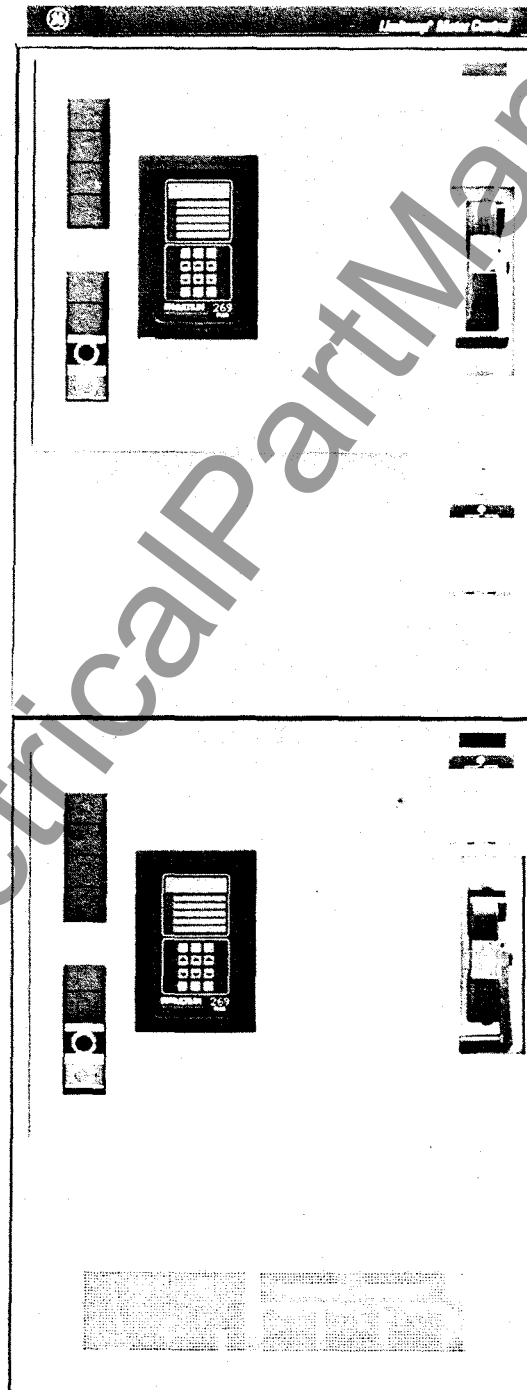

TABLE OF CONTENTS

INTRODUCTION	3
DESCRIPTION	4
Equipment Identification- CR Number Designation	4
General	5
Ratings	5
Basic Impulse Level (BIL)	5
Dielectric Test Voltage	5
High-Voltage Vacuum Contactors	5
Manual Disconnect (Isolation Switch)	6
Mechanical Interlocking	8
Auxiliary Enclosures	8
Dimensions	8
Power Fuses	8
Blown Fuse Indicator & Trip	9
Power Fuse Conversion Instructions	9
INSTALLATION	11
General	11
Receiving	11
Handling	11
Placement of Enclosure	11
Disassembly	11
Contactor Removal	12
Gaining Access to Horizontal Bus for Splicing	14
Taping Instructions for 5kV	16
Reassembly	16
Incoming Power Connections	17
Grounding	17
Motor Cable Termination	18
Cable Termination Guidelines	19
Control Connections	21
Mechanical Operation Check	21
Vacuum Interrupter Integrity Test	24
Preparation of Controller for Operation	25
Megger Check	25
OPERATION	26
Operation Under Test Power	26
Normal Operation	26
Normal High-Voltage Door Opening Procedure	27
High-Voltage Door Defeater Latch	27
INSPECTION, MAINTENANCE & SERVICING	28
Mechanical Operation Check	28
Vacuum Interrupter Integrity Test	28
Vacuum Contactor	28
Isolation Mechanism	28
Torque Recommendations For Electrical Power Connections	30
Preventive Maintenance Guide	30

WARNING: Before any adjustments, servicing, parts replacement or any other act is performed requiring physical contact with the electrical working components or wiring of this equipment, all power must be removed and locked off from all sources and all attached rotating equipment must have come to a complete stop. User personnel must be completely familiar with the following operating and maintenance instructions before attempting to service this equipment.

WARNING: The vacuum interrupter integrity test should be performed before the high voltage vacuum contactor is energized for the first time and each time the contactor is returned to service after maintenance, adjustment or repair. Failure to perform this test may result in serious injury or death.

CAUTION: Product is not intended for nuclear use.

INTRODUCTION

CR194 two-high vacuum Limitamp® controllers are designed to meet NEMA ICS 3, Part 2 "AC General Purpose High-voltage Class E Controllers" and UL 347 requirements, and may be described as metal-enclosed high-interrupting capacity vacuum contactor type starter equipment with manual isolation. Individual starters and controllers are designed for specific applications; the components and functions being dictated by the purchaser specifications and needs. Controllers may be fused or unfused.

The essential control functions for all types of a-c motors consist of starting, stopping and overload protection. Vacuum Limitamp® controllers also include short-circuit protection, and other functions in great variety as may be required for particular applications.

These instructions were prepared as a guide to handling, installation, operation and maintenance of the CR194 two-high vacuum Limitamp® controller. Figure 1 shows a 36"-wide two-high starter with induction motor controllers in top and bottom. Figure 2 shows the same controller with the low-voltage doors open. Figure 3 shows the same controller with the high-voltage doors open.

The intent of these instructions is to give the purchaser the necessary general information to identify his controller as to type and function, to describe suggested methods of installation, and to demonstrate some techniques of operation and maintenance. The purchaser should interpret these instructions for applicability to his particular controller by referring to the nameplate data on the controller and to the electrical diagrams supplied with the controller.

For application questions refer to GET-6840. For details on the high-voltage contactor refer to GEH-5306.

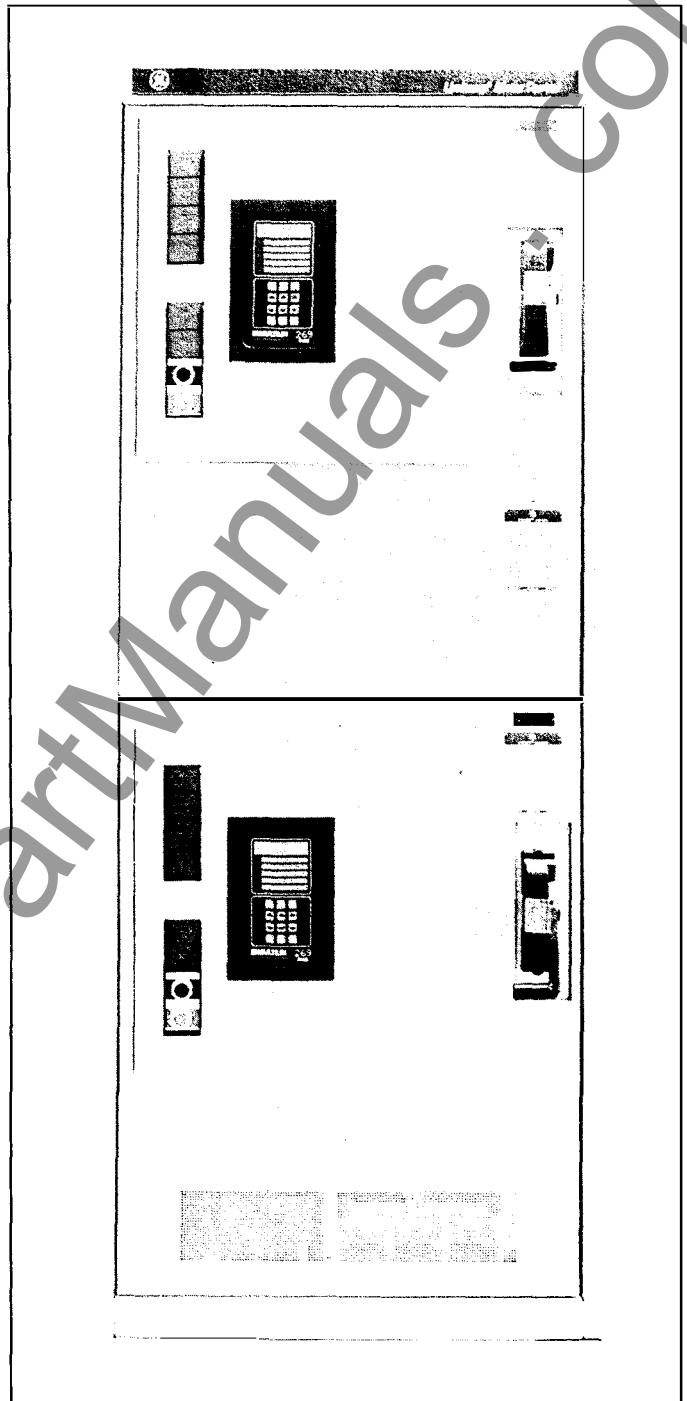

Figure 1. 36"-wide two-high induction motor controllers

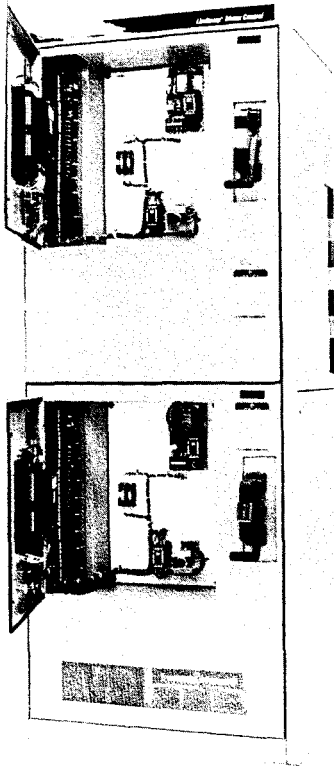

Figure 2. 36"-wide two-high with both low-voltage doors open

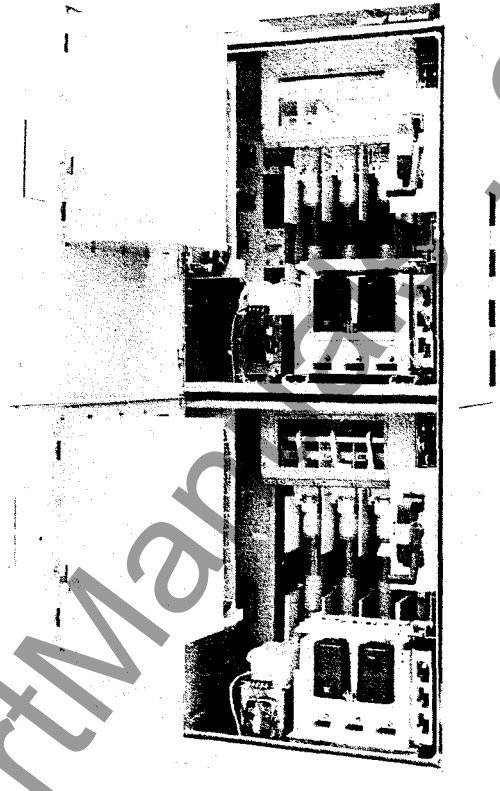

Figure 3. 36"-wide two-high with both high-voltage doors open

DESCRIPTION

Equipment Identification- CR Number Designation

CR194 Two-High Vacuum Limitamp® Control

CR194

Starting and Speed Functions

- A — Single-speed, full voltage
- B — Single-speed, reduced voltage reactor type
- C — Single-speed, reduced voltage, autotransformer type
- D — Single-speed, part winding start
- E — Single-speed, reduced voltage primary resistor
- G — 2 speed, 1 winding full voltage
- H — 2 speed, 1 winding reactor reduced voltage
- J — 2 speed, 1 winding autotransformer reduced voltage
- N — 2 speed, 2 winding full voltage
- P — 2 speed, 2 winding reactor reduced voltage
- Q — 2 speed, 2 winding autotransformer reduced voltage

Rotation and Braking

- 1 — Non reversing/non braking
- 2 — Reversing/non braking
- 4 — Non reversing/dynamic braking
- 5 — Reversing/dynamic braking
- 7 — Reversing/plugging

NEMA TYPE

- 1 = NEMA E1 (Unfused)
- 2 = NEMA E2 (Fused)

Enclosure

- A — 26" 1-HI
- B — 34" 1-HI
- C — 48" 1-HI
- D — 36" 2-HI Stationary
- E — 40" 2-HI Stationary
- F — 36" 2-HI Drawout
- G — 40" 2-HI Drawout

System Voltage

- 7 — 2400 Volts
- 8 — 4200 Volts
- 2 — 7200 Volts
- 0 — Other

Controlled Apparatus

- 0 — Synchronous Motor (brushless type)
- 1 — Induction Motor
- 2 — Synchronous Motor (ring type)
- 3 — Wound Rotor Motor
- 4 — Transformer Feeder
- 5 — Capacitor Feeder
- 6 — Other

General

The basic CR194 two-high vacuum Limitamp® controller is a front connected assembly of components and conductors for motor starting, arranged in a convenient two-high vertical stack. The enclosure allows space and facilities for motor cable termination, plus safety interlocking of doors and isolation switch to prevent inadvertent entrance to high-voltage parts. Unless specified otherwise, the motor cable barriers are installed for bottom motor cable entry, but are easily field converted from bottom to top or top to bottom motor cable entry. Removable conduit cutout covers are provided in both the top & bottom (if a bottom is provided) for bringing in motor cable & control wiring. In an effort to provide for maximum motor cable access in the compact 36"-wide two-high design, incoming power cable must be connected in a separate cable entrance compartment or the two-high must be bus connected to existing equipment. No back access is required, although both back and side access is possible by removal of back and side panels. The equipment may be rated up to 5.0 kV.

In general, the starters in both the top and the bottom are divided into high-voltage and low-voltage compartments, separated by doors and barriers. Mounted on the high-voltage door of each starter is the low-voltage control cavity, with the low voltage door hinged to the high-voltage door. Access to the low voltage panel is obtained by rotating the two ¼ turn latches on the low-voltage door, then opening the door to the left. To open the high-voltage door, the power must be disconnected by a sequence of manual operations which requires de-energizing the high-voltage contactor, operating the isolation switch handle by rotating it downward, loosening the two latch bolts on the high-voltage door, then opening the door to the left. Low-voltage doors may be entered without disconnecting the power, but this should be done with caution.

Installation, operation and maintenance should be performed only by experienced personnel trained in this class of equipment.

Ratings

Refer to the panel data nameplate (see Figure 4) on the front of the enclosure for detailed ratings applicable to a particular controller. Equipment basic ratings equal or exceed NEMA ICS 3, Part 2 for Class E2 Controllers, and are summarized below.

Starter Main Bus & Maximum Current Ratings

Enclosure Type	Main Bus		Starter Max. Current	
	1Bar/Phase	2 Bars/Phase	Top Unit	Bottom Unit
Vented	1200A	2000A	360A	400A
Non-Vented	1200A	1950A	320A	320A

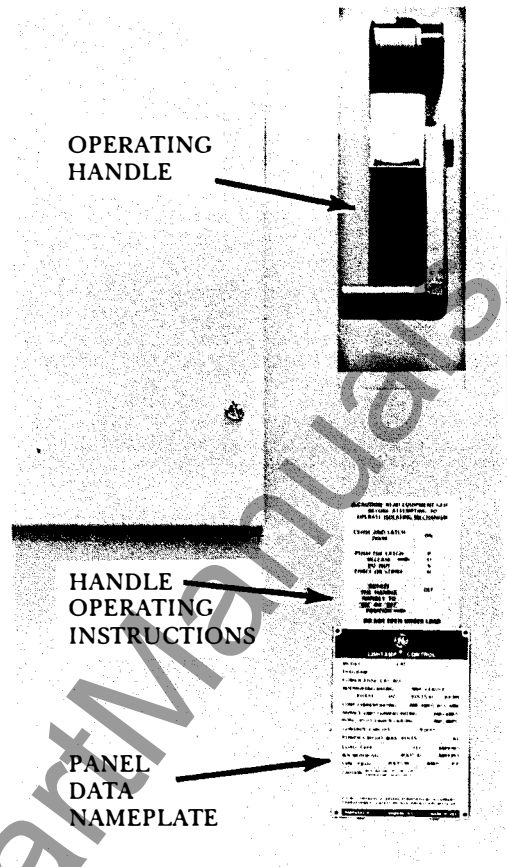

Figure 4. Operating handle, handle operating instructions and panel data nameplate

Interrupting Ratings At Utilization Voltage Shown

Maximum Volts	Maximum Continuous Amperes(RMS)	Three-phase Symmetrical System mVA	
		Class E1 Unfused	Class E2 Fused
2500	400	25	200
3600	400	37	300
5000	400	50	400

Basic Impulse Level (BIL)

The standard BIL rating of vacuum Limitamp® controllers is 60kV crest (design rating). This rating excludes dry-type control transformers and starting reactors & autotransformers.

Dielectric Test Voltage

2¼ times nameplate voltage plus 2000 volts.

High-Voltage Vacuum Contactors

The vacuum contactors used in vacuum Limitamp® controllers are available in two different ratings: 400 and 800 amperes. This publication covers only the 400 ampere rating as used in CR194 two-high vacuum Limitamp®. The 400 ampere and 800 ampere contactors are similar in operation but very different



in size and rating so are not interchangeable. Figure 5 shows the CR194 two-high stationary contactor. Figure 6 shows the CR194 two-high drawout contactor. The 400 ampere stationary contactors in the two-high vacuum Limitamp® and 26"-wide & 34"-wide stationary vacuum Limitamp® are the same basic contactor, but are not directly interchangeable since the auxiliary interlocks and wire harness are mounted differently on the contactors, and the two-high stationary contactor is mounted on a slide base. To use a 26"-wide or 34"-wide 400 ampere stationary contactor in a 400 ampere two-high stationary enclosure, the auxiliary interlocks & wire harness should be removed from the contactor, and the two-high auxiliary interlocks, wire harness & slide base mounted on the contactor. The same procedure but in reverse would be required to use a two-high stationary contactor in a 26" or 34"-wide stationary enclosure.

The stationary contactor is easily removed from the controller by disconnecting the line and load power

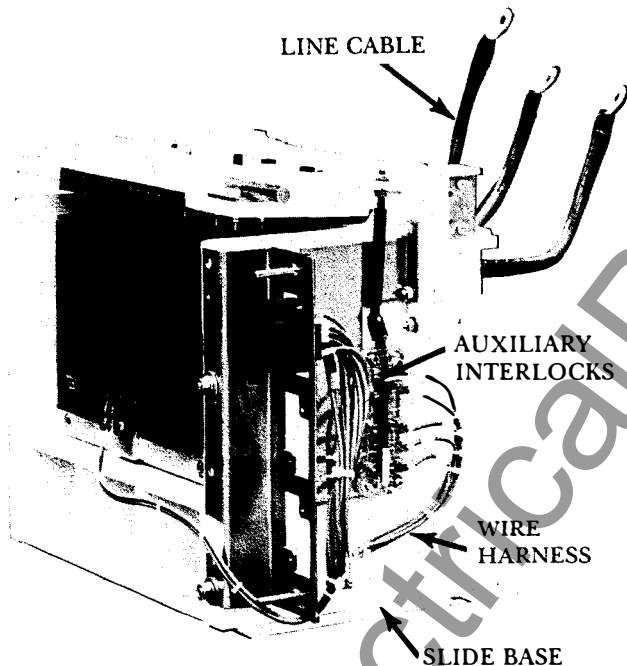

Figure 5. CR194 two-high stationary contactor showing auxiliary interlocks, wire harness, line cable and slide base

connections and sliding the contactor out. The auxiliary contacts are electrically connected by means of a removable umbilical cord plug that is retained by two wing nuts. By removing these wing nuts, the wiring harness is easily disconnected from the contactor. The drawout contactor is removed in a similar manner by first removing the Positioning Bolts then sliding the contactor out. Refer to the section titled "Contactor Removal" that details these procedures.

The contactor is magnetically operated by a DC coil fed by a rectifier and timed holding circuit. The base mounted contactor timing module (CTM) shown in Figure 7 applies full voltage to the contactor for a time sufficient to fully close the contactor. Then it inserts a capacitor into the circuit to hold the contactor closed at a reduced voltage to prevent overheating the coil and provide for fast dropout when power is removed.

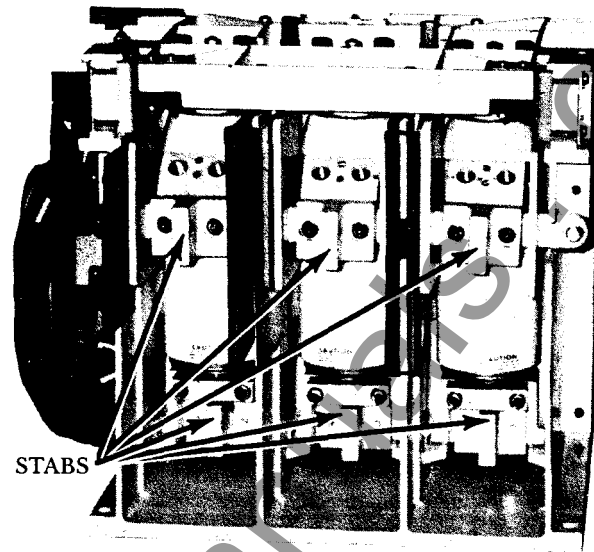

Figure 6. Rear view of CR194 two-high drawout contactor showing stab connectors.

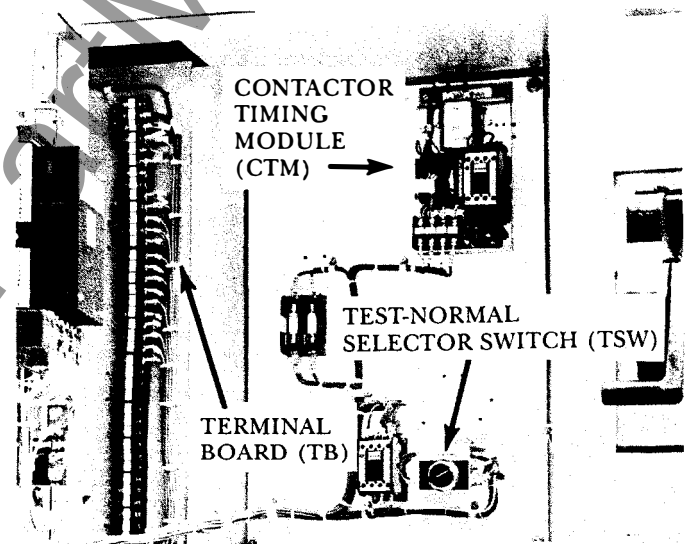

Figure 7. View of low-voltage compartment showing contactor timing module (CTM), test-normal selector switch (TSW) and terminal board (TB)

Manual Disconnect (Isolation Switch)

CR194 two-high vacuum Limitamp® controllers, following the NEMA definition, provide a means for manually isolating the high-voltage power circuit by operation of a disconnecting device. Each starter cubicle (upper & lower) has its own disconnecting mechanism, which consists of a quick-make, quick-break, non-load break isolation switch (see Figures 8-11) which is controlled by an operating handle (see Figure 4). A fixed barrier (Figures 10 and 11) with a viewing window is supplied to provide isolation from the energized bus parts.

NOTE: The quick-make, quick-break isolation switch will not interrupt any load or fault current.

The isolation switch handle will accept up to four padlocks to prevent operation. See Figure 12.

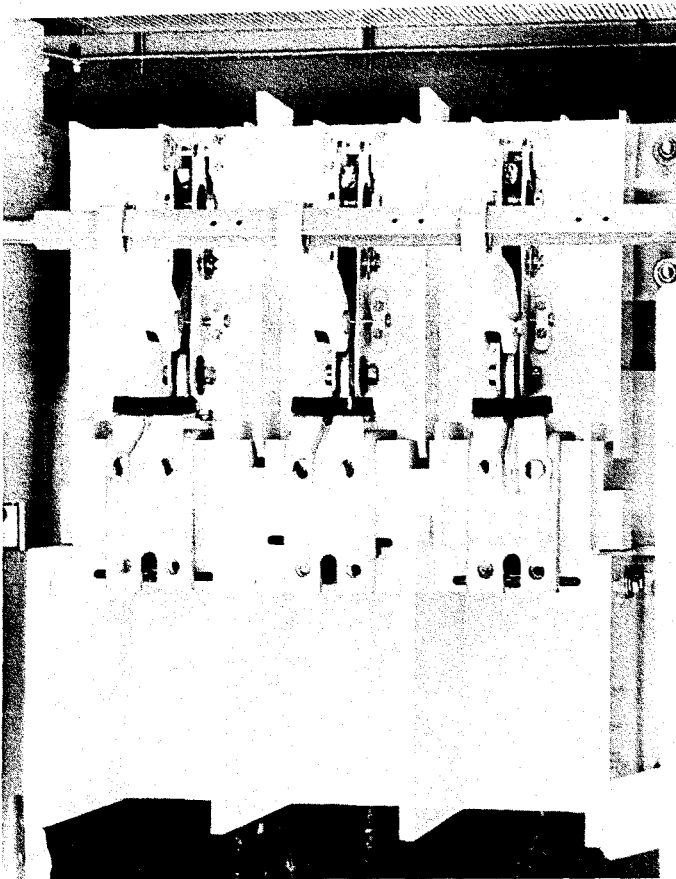

Figure 8. View of isolation switch in the "ON" position. Barriers and fuses are removed for clarity.

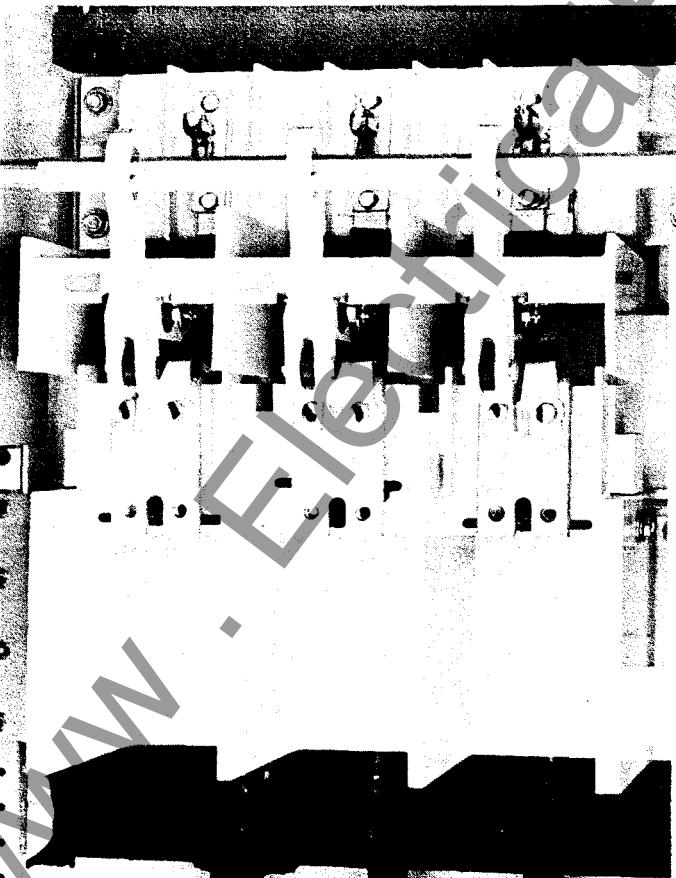

Figure 9. View of isolation switch in the "OFF" position. Barriers and fuses are removed for clarity.

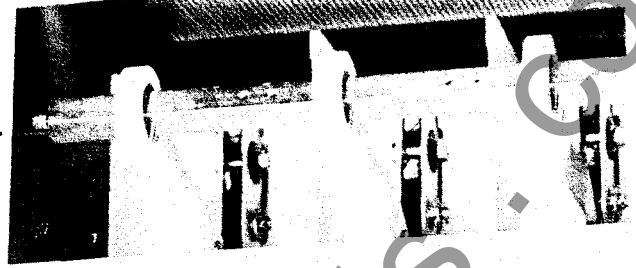

Figure 10. View of isolation switch in the "ON" position. All barriers installed except for the front transparent viewing window.

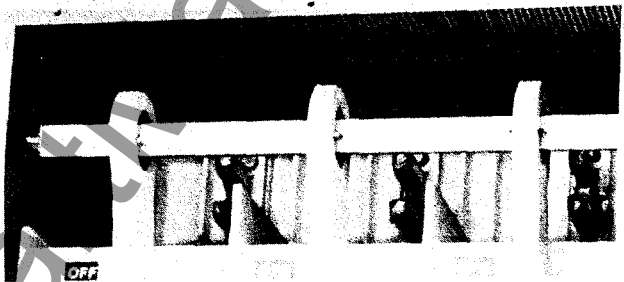

Figure 11. View of isolation switch in the "OFF" position. All barriers installed except for the front transparent viewing window.

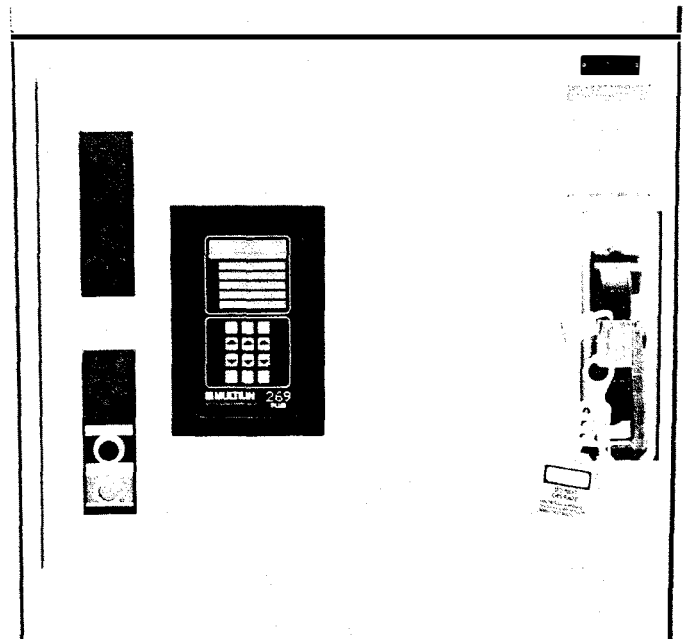

Figure 12. The isolation switch handle may be padlocked to prevent operation.



Mechanical Interlocking

Vacuum Limitamp® equipment is designed so that the high-voltage contactor performs all normal load current interrupting. The current limiting fuses generally interrupt any fault currents.

NOTE: The quick-make, quick-break isolation switch will not interrupt any load or fault current.

A mechanical interference system is included with all vacuum Limitamp® controllers (mechanical interlock) which prevents opening the isolation switch unless the high-voltage contactor itself is demonstrated by magnet position to be already open. This is to insure that the contactor has opened the power circuit and interrupted the current before the isolation switch is operated. See Figure 13.



Figure 13. Contactor engagement pawl for mechanical interlock

WARNING: The isolation switch handle should never be forcibly operated. Its mechanical interference interlock should be defeated only by knowledgeable and qualified electrical maintenance personnel who have de-energized all power feeding the controller.

WARNING: There is no emergency condition that can justify forcible operation of the isolation switch handle with the main contactor closed. The isolation switch handle must be operated only with the contactor open.

The high-voltage doors on the CR194 two-high vacuum Limitamp® are mechanically interlocked with the isolation switch handle which keeps the high voltage door closed until the isolation switch is in the "OFF" position. This is done to prevent exposure to high voltage. Other high voltage doors in a diverse Limitamp® lineup may use either mechanical linkage interlocking or key type interlocking to prevent access to high-voltage components such as reactors, autotransformers, auxiliary transformers, power factor capacitors, etc. In all cases of key interlocking, it is very important and imperative to follow the key lock operating scheme as described in the drawings furnished with the equipment.

Auxiliary Enclosures

Many types of enclosures are furnished in vacuum Limitamp® control lineups for various purposes. Some are listed below:

- Wound rotor secondary contactor and resistor compartments
- Bus transitions to switchgear, transformer, bus duct, etc.
- Cable entrance compartments
- Synchronous exciter compartments
- Starting reactor & autotransformer compartments
- Relay & metering compartments
- Non load-break switch compartments
- IC1074 load-break switch compartments

The details for these enclosures will be included in the drawings furnished with the equipment.

Dimensions

Vacuum Limitamp® controllers are normally 30-inches deep and 90-inches high. The width of the CR194 two-high vacuum Limitamp® is 36 inches (40 inches optional). See Figure 50 for dimension details.

Power Fuses

Bolted EJ-2 type current limiting power fuses are supplied as standard with vacuum Limitamp® controllers. Clip-in fuses are available as an option to cover requirements for EJ-1 type fuses, but the blown fuse (anti-single phase) indication/trip functions are not available with clip fuses, since this feature requires precise alignment of the striker pin at the top of the fuse with the operators. Coordination information for EJ-2 type fuses is available in GES-5000, and for EJ-1 type fuses, GES-5002. Interrupting ratings are shown in the "Ratings" section of this instruction.

Blown Fuse Indicator & Trip

All bolted EJ-2 type fuses have inherent blown fuse indication because the striker pin at the top of the fuse protrudes out when the fuse is blown. In the CR194 two-high, the striker pin drives the blown fuse indicator and trip bar which operates the blown fuse trip (BFT) contact block. The BFT contact block can be wired to trip the controller off line to prevent single phasing of the connected load (anti-single phase protection). It can also be wired to an optional blown fuse indicator mounted on the low-voltage door. Figure 14 shows the top of the bolted power fuse assembly with the center blown fuse indicator in the “blown” position and the two outside blown fuse indicators in the “normal” position. Figure 15 shows the BFT contact block, with wiring removed for clarity.

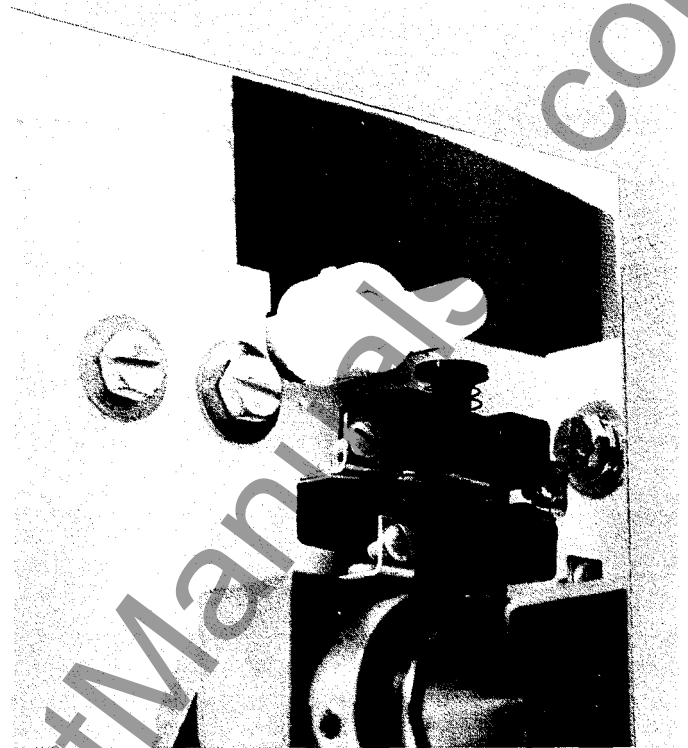

Figure 15. Blown fuse trip (BFT) contact block with wiring removed for clarity

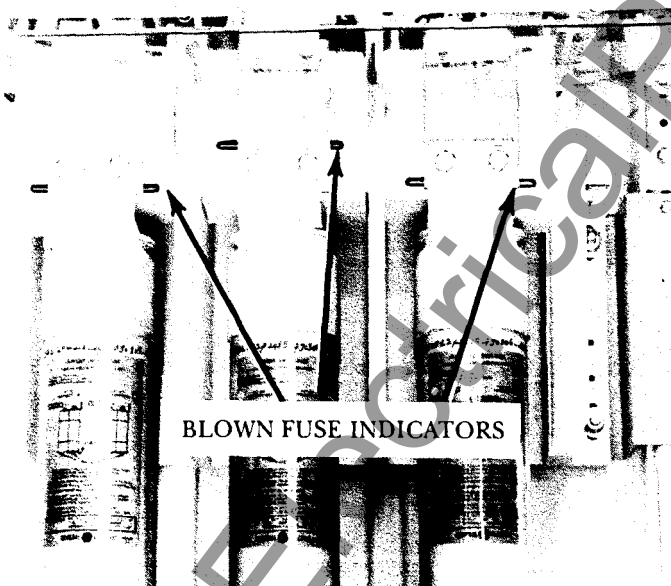

Figure 14. Blown fuse indicators with center phase indicating “blown” and outside phases indicating “normal”



THIS PAGE BLANK

www.ElectricalPartManuals.com

INSTALLATION

General

This section contains information on receiving, handling, disassembly, motor cable termination, grounding and reassembly to make the equipment ready for operation.

Receiving

CR194 two-high vacuum Limitamp® controllers are rigid, self supporting steel enclosures that require no floor sills. They are placed on skids and shipped in an upright position and, when received, should be kept upright.

Some components such as top-mounted potential transformers may be shipped separately. These components are identified by a catalog number coinciding with that of the section on which they are to be mounted.

Plastic film wrap is normally used for domestic packing, with the steel enclosure sections bolted to a wooden skid. After receiving, the packing may be removed and the equipment handled on the wooden skid.

The equipment should be inspected for damage that may have occurred during shipment, and any such damage should be noted to the carrier if a claim is to be made.

Handling

It is always preferable to handle Limitamp® controllers by the lifting means provided. A single section should be lifted by connecting directly to the two lifting lugs on top. However, an equalizing bar should be used for a lineup as shown in Figure 16. A lineup should be supported at as many points as possible.

If there is not enough head room to lift the panel by its lifting means, then a track jack can be used. The controller can be raised by placing a track jack under the shipping skid. Rollers can then be placed under the skid for rolling the equipment to its final location. The panel should then be raised by its lifting means, the shipping skid removed, and the panel set into place.

The use of fork lift trucks is not recommended, since the forks may damage the enclosure or interior parts of the equipment, and the equipment becomes very unstable when lifted from the bottom. If no other method of handling is available, the forks must go under the skid bottom to avoid damaging the equipment, and the assembly lifted only slightly to allow the skid to be slid along a flat, level surface.

Placement of Enclosure

It is essential that the controller be securely fastened in an upright position on a level surface to allow proper functioning of the internal devices. Access will be improved if the controller is located at floor level with

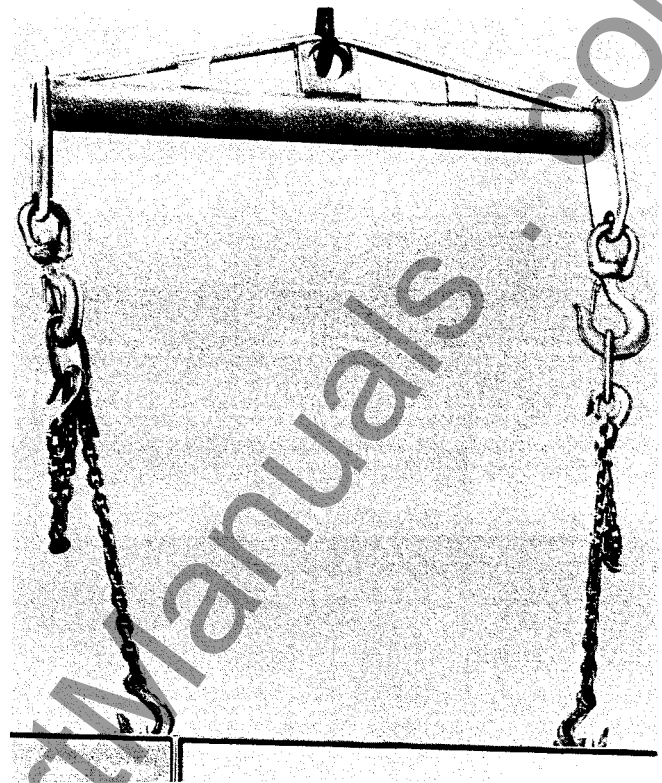

Figure 16. Recommended method of lifting a vacuum Limitamp® line-up.

Note that the line-up is suspended from an equalizing bar

plenty of room allowed for doors to swing fully open as shown on the drawings as supplied with the equipment.

After the controller has been placed in position, floor mounting anchor bolts may be installed and tightened. The location for these bolts for the CR194 two-high is shown in Figure 50, and on the Outline Details section of the drawings furnished with the equipment. Use ½-inch bolts as indicated in Figure 50.

Disassembly

After the equipment has been set in place where it is to be permanently connected, some internal disassembly is required to make the necessary horizontal main bus and ground bus connections. Further disassembly is required if it is desired to view the horizontal-to-vertical bus connection. Disassembly should be done in a definite sequence as indicated below.

NOTE: Other than the removal of external cover plates as required, and/or the rearrangement of the incoming motor cable barriers if required, disassembly is not required to run motor cable and control wire into the enclosure. Under normal circumstances, disassembly need only be done to the extent necessary to make the horizontal bus splice connection.



DISASSEMBLY SEQUENCE:

WARNING: Confirm that equipment is de-energized before proceeding with disassembly.

NOTE: If the rear of the enclosure is accessible, access to the horizontal bus for splicing can be accomplished simply by removal of the upper cover from the rear of the enclosure. Figure 28 shows the rear of the enclosure with the upper and lower covers removed.

Step 1.

Move the isolation switch handles in both the upper & lower starters to the full "OFF" (down) position (i.e. the handle latch release pops back out). Refer to the handle operating instruction nameplate attached to the high-voltage door near the handle (See Figure 4). Figure 17 shows the method of first depressing the handle latch release with one hand and moving the handle with the other.

Step 2.

Open both the upper & lower high-voltage doors.



Figure 17. Operate handle by depressing handle latch release with one hand and moving the handle with the other.

Contactor Removal

NOTE: Before starting Contactor Removal procedure, perform Steps 1 & 2 above.

NOTE: The following steps describe the procedure for contactor removal for either the upper or lower starter, but in order to gain access to the main bus splices, removal of only the upper starter contactor is necessary.

Step 3.

Remove the two wing nuts holding the contactor umbilical cord plug on the right side of the contactor. Disconnect the plug and place it to the lower, right out of the way.

NOTE: For stationary mounted contactors, follow Steps 4 and 5, then go to Step 7. For drawout contactors, go to Step 6.

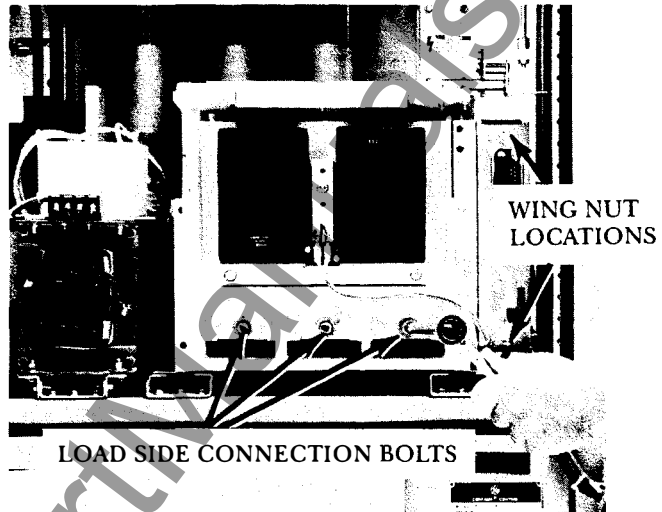

Figure 18. View of the stationary contactor showing removal of load side connection bolts and contactor umbilical plug wing nut locations

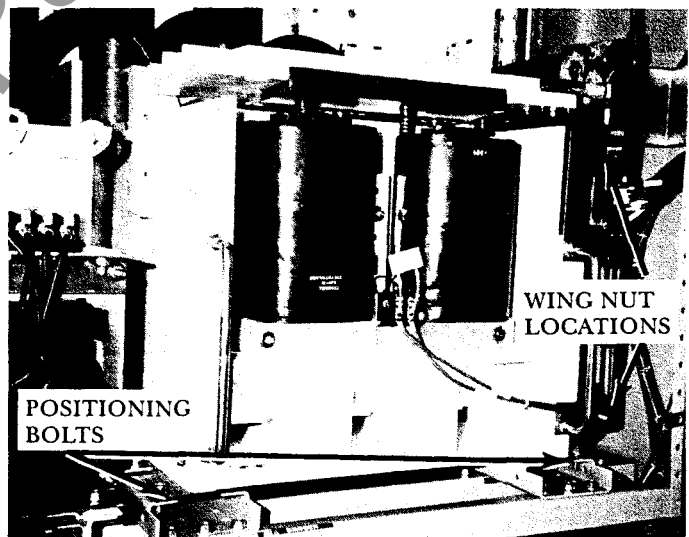

Figure 19. View of high voltage section showing the two drawout contactor positioning bolts and wing nut locations.

Step 4.

Remove the three load side connection bolts at the bottom, front of the contactor. Do not loosen the R.T.V. covered bolts. See Figure 18.

Step 5.

Remove the three line side cable bolts at the bottom of the power fuse assembly. See Figure 20.

Step 6.

Remove the two positioning bolts. See Figure 19.

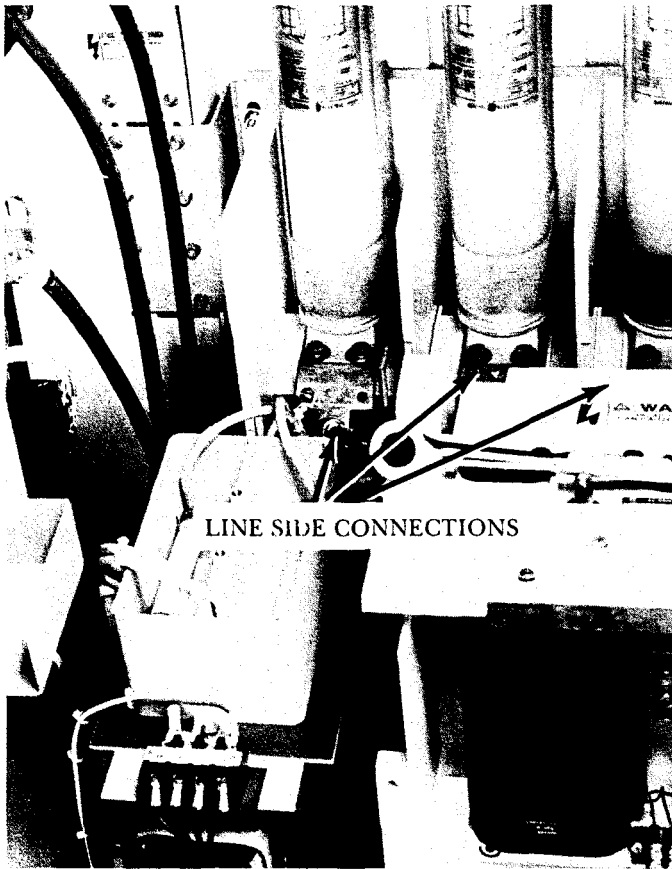

Figure 20. View showing stationary contactor line side cable connections at the power fuses

Step 7.

Slide the contactor forward approximately four (4) inches until the slide safety stop engages in the plate that is attached to the bottom of the contactor. The safety stop is located on the left side of the contactor mounting track. Figure 21 shows the safety stop for a stationary contactor with the contactor removed for clarity.

CAUTION: In the next step to remove the contactor from the enclosure, be aware that the contactor weighs 75 pounds and should be handled very carefully & deliberately using both hands. Do not grasp the contactor by the top moving armature.

NOTE: A platform lift jack is available from GE that can be used to aid in contactor removal and transport. Order catalog No. 55B534913P1.

Step 8.

To completely remove the contactor from the enclosure, pull up on the safety stop and move the contactor forward about one (1) inch. Then release the safety stop and grasp the contactor with both hands and move it forward and out of the enclosure. Do not grasp the contactor by the top moving armature.

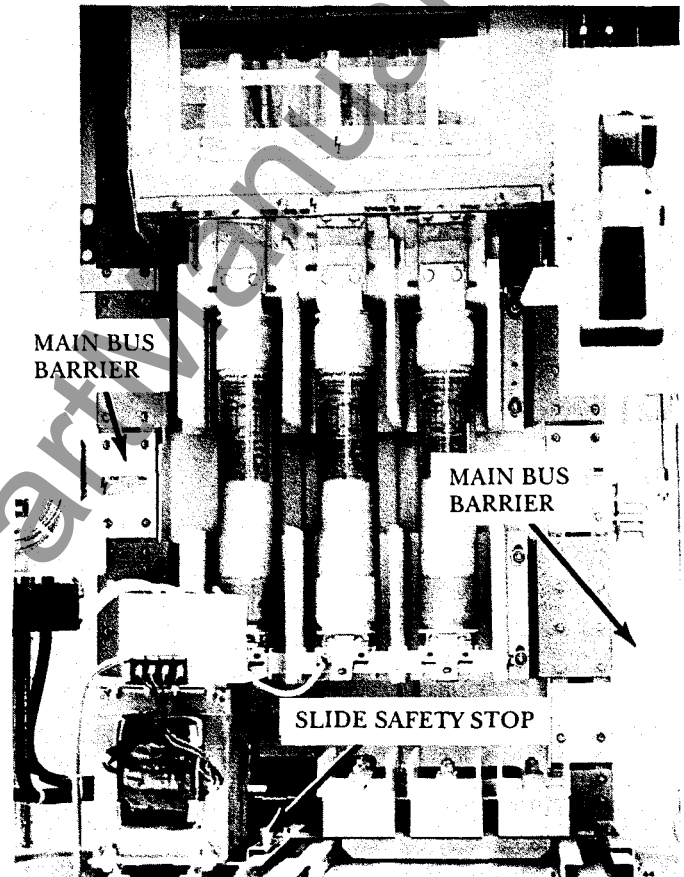

Figure 21. View of slide safety stop and main bus barriers with stationary contactor removed



Gaining Access To Horizontal Bus For Splicing

WARNING: Confirm that equipment is de-energized before proceeding with disassembly.

NOTE: Insure Steps 1-8 above are completed before proceeding with disassembly.

Step 9.

Once the upper contactor has been removed, the side main bus barriers are accessible at the rear of the compartment. See Figure 21.

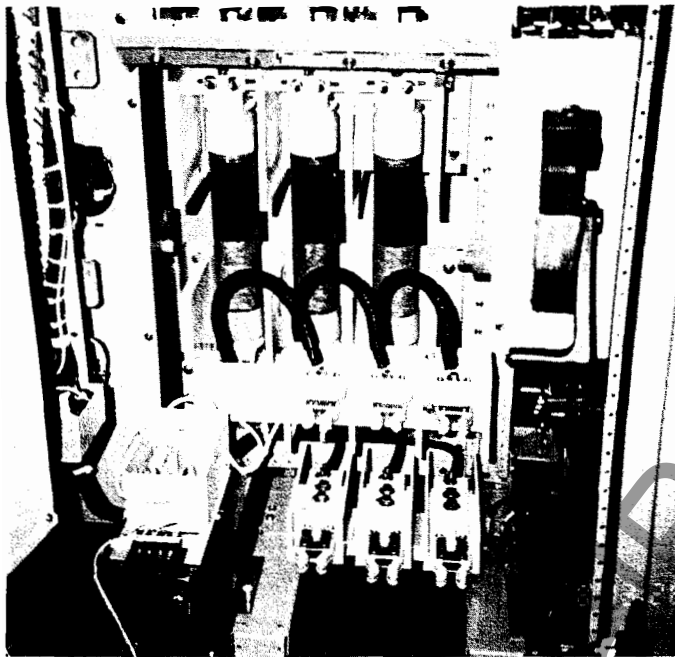

Figure 22. View of CR194 two-high high voltage section with drawout contactor removed.

Step 10.

Remove the mounting bolts that hold the side main bus barriers in place. Once the barriers are removed, the ends of the main bus bars are visible as shown in Figure 23. Main and ground bus splices may now be made to the section on either the left or right side of the starter.

Step 11.

Install bus splices per Figure 51. Once main bus splices are installed, they must be taped in order to maintain required electrical clearances. See "Taping Instructions for 5kV" Section.

WARNING: Main bus splice bars must be taped once they are installed in order to maintain required electrical clearances. (See "Taping Instructions for 5kV" Section).

NOTE: If additional access is required on the left side of the compartment, the control power transformer (CPT) and transformer fuse block may be removed per Step 12 below. If CPT & CPT fuse block removal is not required, skip to the note under Step 12.

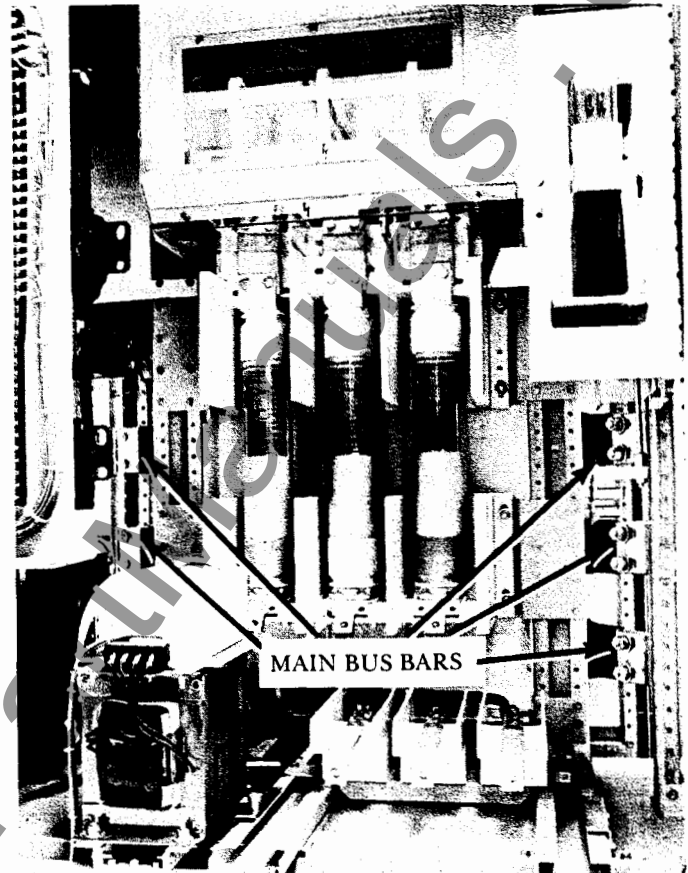

Figure 23. Ends of main bus exposed for splicing (stationary contactor removed)

Step 12.

To remove the CPT, disconnect the control wires that are attached to the transformer terminal board and disconnect the two CPT high-voltage fuse leads that attach to the lower terminals of the power fuse assembly. Then remove the transformer and fuse block assembly by removing the four (4) bolts that mount the transformer. See Figure 24 for view with CPT, CPT fuse block and power fuses removed.

NOTE: It is typically not necessary to gain access to the main to vertical bus connections, but this option is available as detailed in Steps 13-16. If access to these connections is not required, then disassembly is complete.

Step 13.

To access the main to vertical bus joints in the center of the main bus, additional parts must be removed as outlined below. First remove the three power fuses.

Step 14.

Remove the lower power fuse base assembly by removing the eight (8) mounting screws on each side of the lower fuse base assembly. Figure 25 shows the compartment once the lower fuse base assembly has been removed.

Step 15.

Remove the screws that mount the contactor lower terminal assembly as shown in Figure 25. Also remove the four (4) screws that mount the "U" shaped insulation barrier at the rear of the compartment as shown in Figure 25.

Step 16.

Move the contactor lower terminal assembly forward and lift up and pull forward at the bottom of the "U" shaped insulation barrier at the rear of the compartment as shown in Figure 26. The barrier can then be completely removed from the enclosure to fully expose the main to vertical bus joints as shown in Figure 27, which completes the disassembly.

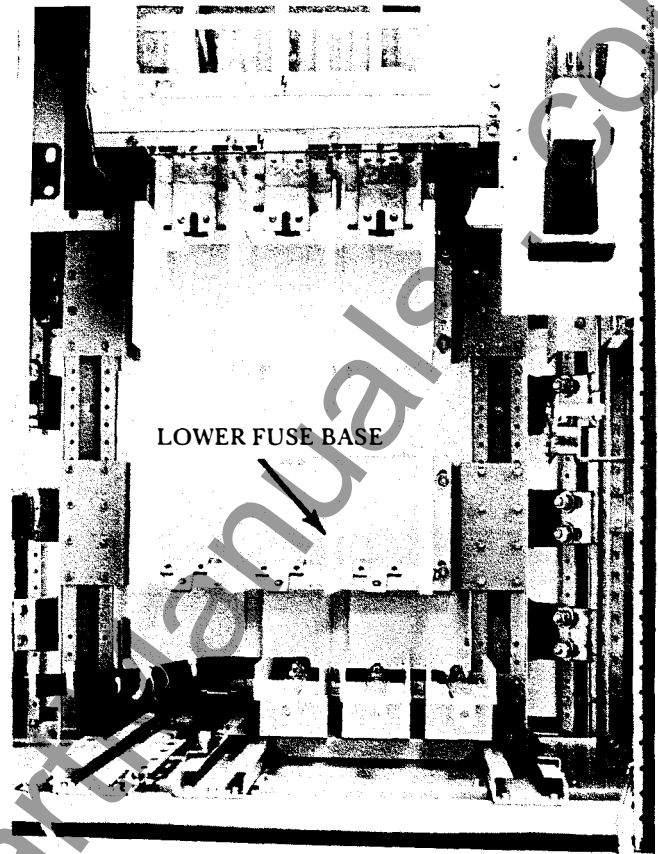

Figure 24. CPT and stationary contactor removed to provide better access to main bus bars on left side

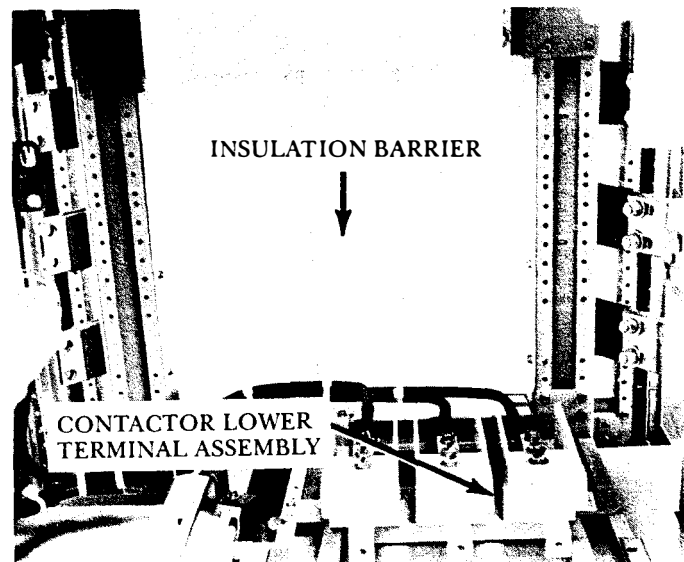

Figure 25. View with lower fuse base assembly removed (stationary contactor design)

www.ElectricalManuals.com

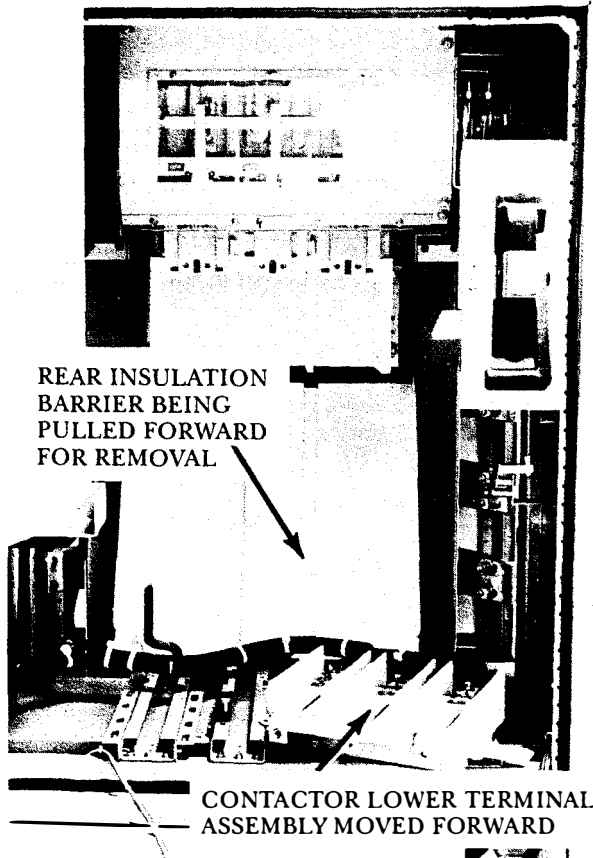

Figure 26. Removal of rear insulation barrier to expose main to vertical bus joints (stationary contactor design)

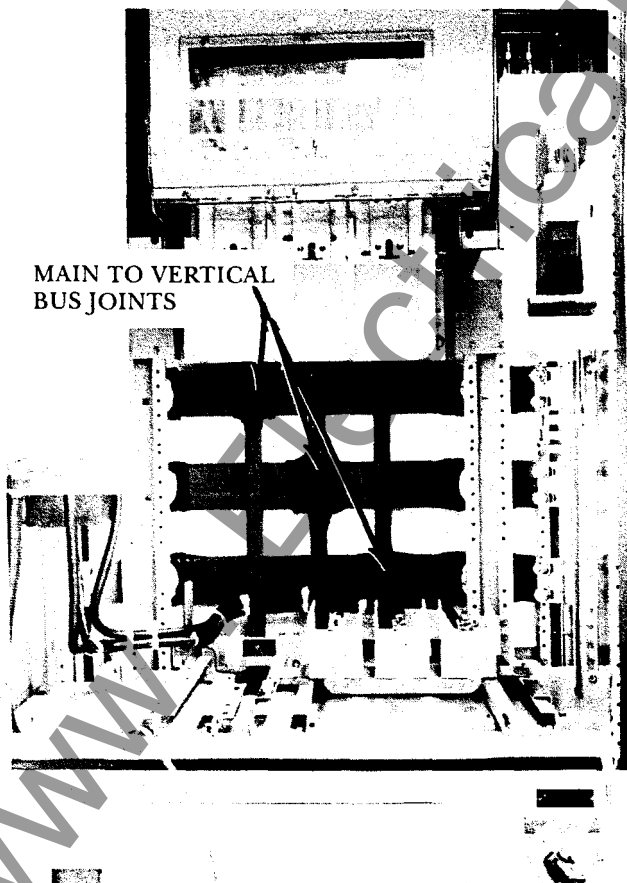

Figure 27. View of main and vertical bus area with all barriers removed (stationary contactor design)

Taping Instructions for 5kV

For electrical clearance, motor terminals and bus splices in the CR194 two-high must be taped. Use Scotch #130C linerless rubber splicing tape. Apply tape using a medium tension to thin the 0.030" X 2" tape to 0.024" X 1.75". When completing wrapping, do not keep tension on the last 2 or 3 inches of tape in order to improve adhesion. Apply tape in two layers with 2/3 overlap (6 thicknesses). For bus splicing, extend the tape out of the two-high enclosure only far enough to realize a 3.5" clearance from bare bus to ground. When taping motor cable terminations, tape the lug and entire cable terminal pad, and if window CT's are used, overlap the tape onto the terminal pad insulator support approximately one inch.

Reassembly

Reassembly of the equipment should be done by following the disassembly sequence in the reverse order, being sure that all removed barriers get reinstalled properly and following the contactor installation procedure below.

WARNING: Do not attempt to operate equipment without all barriers in place.

Since reinstallation of the high-voltage stationary contactor involves bolted high-voltage power connections, not only is it necessary to follow the correct reassembly sequence, but also the bolted power connections need to be properly torqued as well. When replacing the contactor in the enclosure, the following procedure should be followed:

Step 1.

If the contactor is a stationary type, insure that the cables attached to the line side of the contactor are properly torqued to 39 ft-lb.

NOTE: Do not grasp the contactor by the top moving armature during installation.

Step 2.

Place the contactor onto its mounting base and slide the contactor in until the slide safety stop engages and latches the contactor in the intermediate position. Then pull up on the safety stop and push the contactor fully into the unit. Insure that the armature interlock is properly engaged in the interlock pawl on the right side wall. See Figure 13 for close-up of interlock pawl and Figure 40 for view of proper engagement.

WARNING: The interlock pawl transmits the contactor armature motion to the mechanical interlock. It is vital that this mechanism functions properly.

Step 3.

If the contactor is a stationary type, install and torque the three load side connection bolts to 16 ft-lb. (See Figure 18), then attach the line cables to the bottom of the fuse assembly and torque these connections to 9 ft-lb. (See Figure 20).

WARNING: Be absolutely certain that these bolts are properly installed and torqued. These are current carrying connections and must be tight or damage will result.

Step 4.

If the contactor is a drawout type, reinstall the two positioning bolts (See Figure 19).

Step 5.

Manually operate the contactor armature and observe that the mechanical interlock functions properly.

Step 6.

Reconnect the control umbilical cord to the contactor and be sure the retaining wing nuts are tight. Installation of the contactor is now complete.

WARNING: Make certain that all barriers are replaced and bolted tightly into position. Make sure the line and load side terminations of the stationary contactor are torqued properly. If the contactor is drawout type, make sure the positioning bolts are installed properly. Failure to perform these operations could result in failure of the unit to operate safely and reliably.

Incoming Power Connections

The compact design of the two-high vacuum Limitamp® does not make it practical to terminate incoming power cables within the starter. The equipment must either be bus spliced to existing equipment or supplied with a separate cable entrance compartment. If a separate cable entrance compartment is supplied, refer to the Outline Summary & Outline Details sections of the drawings provided with the equipment to determine the recommended location for incoming power cable entry. Also see the "Cable Termination Guidelines" section of this instruction.

Grounding

All controller enclosures must be grounded, and the CR194 two-high vacuum Limitamp® is equipped with a ground bus for that purpose. The two-high ground bus should be bus connected to existing equipment or to a separate cable entrance compartment. Figure 28 shows the ground bus as seen from the rear of the enclosure with the back cover removed.

In order to accommodate motor cable grounds, each starter cubicle is equipped with a ground bus link that is connected directly to the horizontal ground bus. See Figure 29.

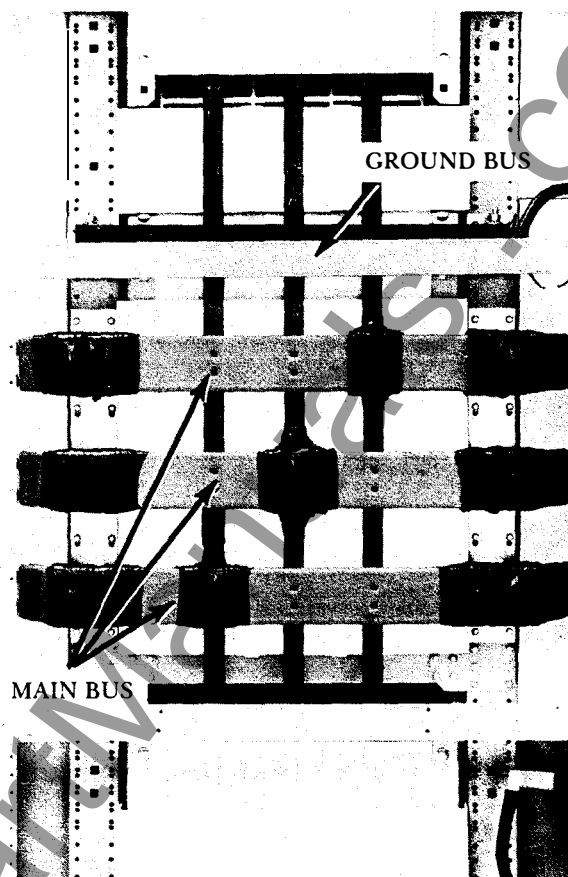

Figure 28. Rear view of horizontal main and ground bus with back covers removed

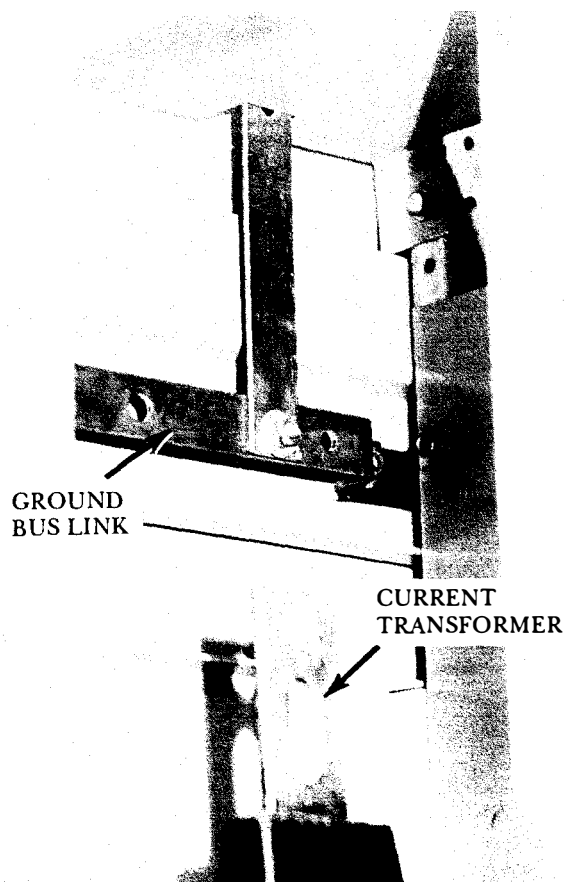

Figure 29. View of motor terminal area showing ground bus link in lower starter



Motor Cable Termination

Each starter enclosure is equipped with provisions to run motor cables into the top or bottom of the enclosure. Removable conduit cutout covers are provided in both the top & bottom (if a bottom is provided) for bringing in motor cable. Figure 30 shows the covers in the top. Cable size limits are indicated below. The motor cable troughs are located on the left side of the equipment as shown in Figure 31. See the "Cable Termination Guidelines" section of this instruction for additional information

MOTOR CABLE SIZE LIMITS IN CR194 TWO-HIGH LIMITAMP®

Enclosure Width	With Non-Shielded Cable	With Shielded Cable and Prefabricated Stress Cones	With Shielded Cable and Hand-Wrapped, Non-cone Stress Relief
36"	1-500 kcmil	1-250 kcmil Preferred 1-500 kcmil Possible	1-#3/0 Preferred 1-#4/0 Possible
40"	1-500 kcmil	1-500 kcmil	1-250 kcmil

If all barriers, including the properly placed motor cable trough barriers, are in place, the top starter can be motor cabled with the bottom starter energized and "ON", and the bottom starter can be motor cabled with the top starter energized and "ON".

WARNING: If one starter is to be motor cabled with the other starter energized and/or "ON", all barriers including the motor cable trough barriers must be properly installed (see below) and the isolation switch handle for the unit being cabled must be in the "OFF" (down) position and the blades must be visibly checked to insure that they are disconnected from the vertical bus.

When the equipment is shipped it will be assembled for motor cable entry from the direction specified on the order. If this information is not known by the factory, the unit will be shipped suitable for bottom entry. Once the equipment is installed in the field, the cable entry path can be revised by following the steps listed below.

CABLE ENTRY FROM BOTTOM

Step 1.

Cables to the bottom starter should be run straight into the motor terminals using the "lower unit" area as shown in the floor-plan view in Figure 50.

Step 2.

Cables to the top starter should be run in the motor cable trough using the "upper unit" area as shown in the floor plan view in Figure 50. This cable trough is formed by two metal barriers in the left rear corner of the lower compartment. Once the cables enter the upper compartment they can be formed forward to align with the motor terminals.

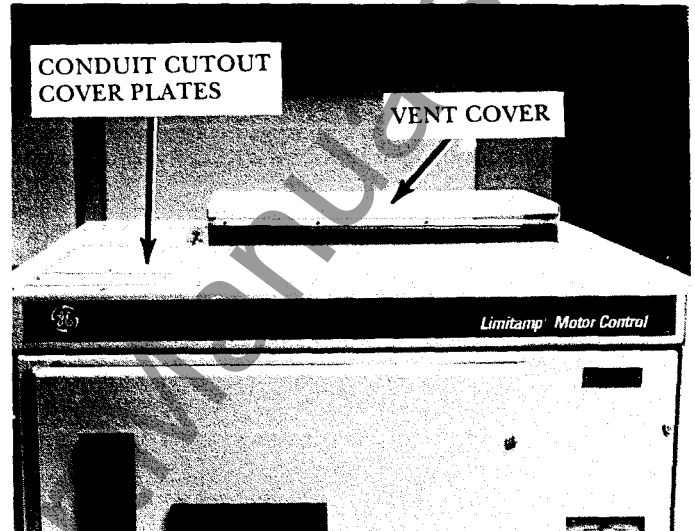

Figure 30. Top view of two-high enclosure showing conduit cutout cover plates

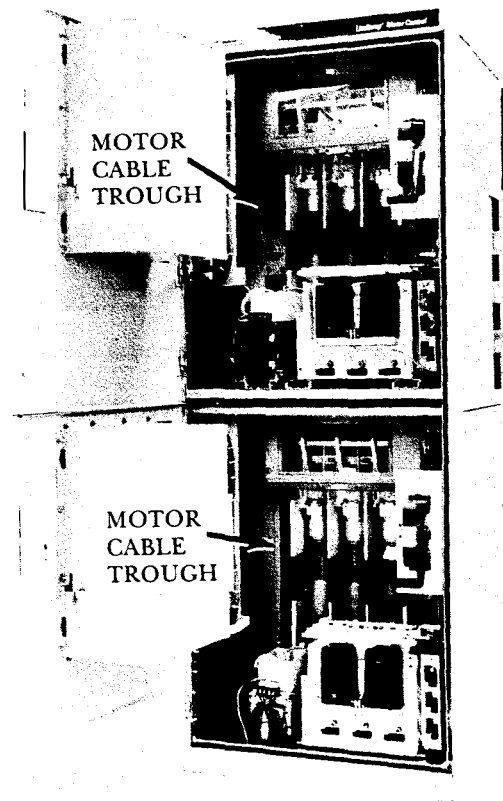

Figure 31. High-voltage doors open showing motor cabling area

NOTE: If the two metal barriers that form the rear cable trough (See Figure 32) are mounted in the upper compartment, they can be moved to the lower compartment to form the necessary trough.

WARNING: Once the motor cables are terminated, the cable lugs and the complete motor terminal pads must be taped to maintain necessary electrical clearances. (See "Taping Instructions for 5kV" section).

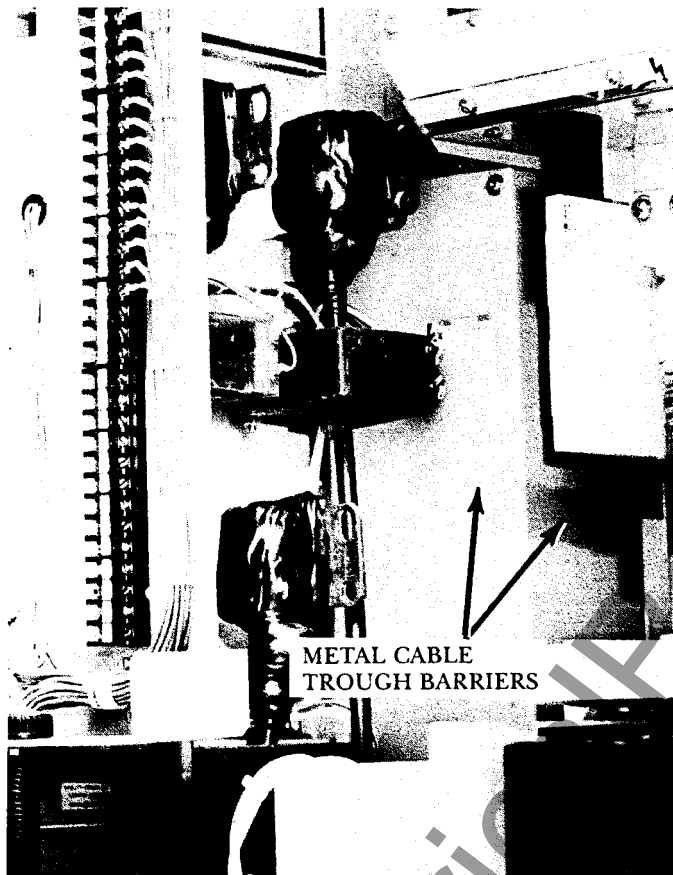

Figure 32. View of cable trough barriers that mount in top or bottom compartment

CABLE ENTRY FROM TOP

Step 1.

Cables to the top starter should be run straight into the motor terminals using the "upper unit" area as shown in the top view in Figure 50.

Step 2.

Cables to the bottom starter should be run in the motor cable trough using the "lower unit" area as shown in the top view in Figure 50. This cable trough is formed by two metal barriers in the left rear corner of the upper compartment. Once the cables enter the lower compartment they can be formed forward to align with the motor terminals.

NOTE: If the two metal barriers that form the rear cable trough (See Figure 32) are mounted in the lower compartment, they can be moved to the upper compartment to form the necessary trough.

WARNING: Once the motor cables are terminated, the cable lugs and the complete motor terminal pads must be taped to maintain necessary electrical clearances. (See "Taping Instructions for 5kV" section).

Cable Termination Guidelines

The following general guidelines apply whether motor cable or incoming power cable is being terminated in the Limitamp® lineup. In any installation, cable should be prepared for termination in accordance with the instructions of the cable manufacturer.

Step 1.

Pull in the cables for maximum clearance between phase, ground and other cable or wire runs.

Step 2.

Prepare the cable for termination in accordance with the manufacturer's instructions. Some possible termination methods are shown in Figures 33-38.

Step 3.

Bolt the cable terminals to the point of termination.

Step 4.

If contact between the cable and an adjacent bare bus cannot be avoided, as well may be the case in some incoming line situations, tape the bus in the immediate vicinity of the cable contact point so that the surface creepage distance from the cable to the bare bus bar is at least three inches. Thus the surface creepage from the bare bus where the cable terminates to the nearest bare part of the bus the cable touches will be at least seven inches. (See "Taping Instructions for 5kV" section).

TERMINATION OF NON-SHIELDED, NON-LEAD-COVERED CABLE

This cable is generally run through rigid conduit or cable raceways and brought into the enclosure by the use of conventional cable clamps and conduit fittings. Refer to Figures 33 & 34 for termination details.

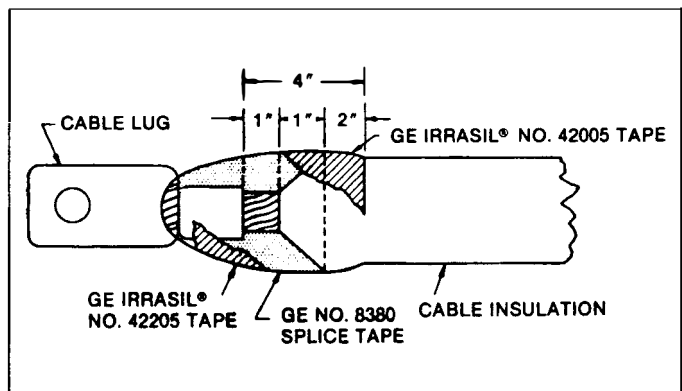

Figure 33. Termination of rubber-insulated, non-shielded, non-lead-covered, 5000-volt cable

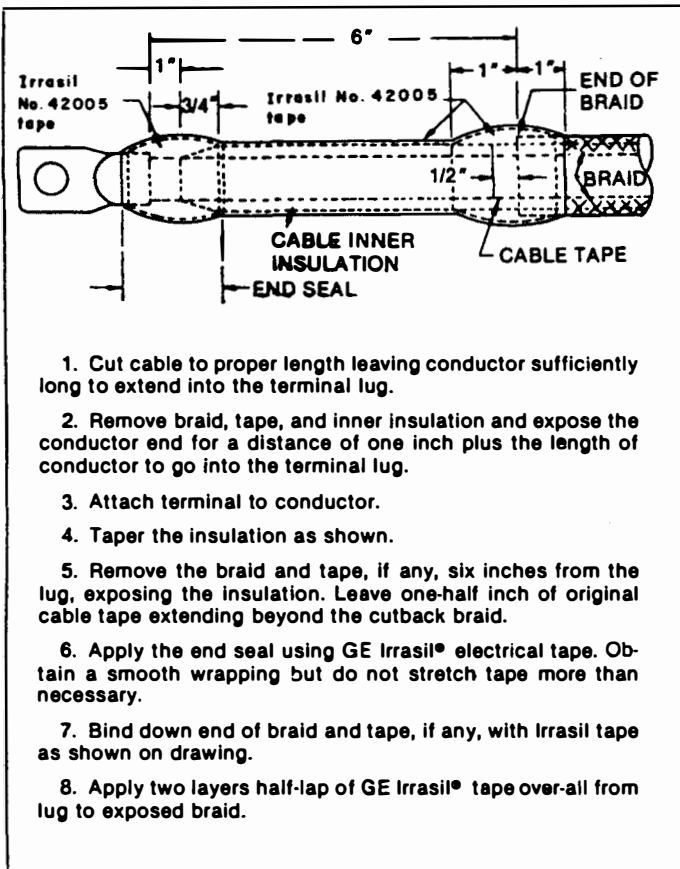

Figure 34. Termination of varnished-cambric-insulated, non-shielded, non-lead-covered, 5000-volt cable

TERMINATION OF INTERLOCKED-ARMOR CABLE

Interlocked-armor cable is terminated by means of specially designed cable fittings. These terminators consist generally of mounting bracket, armor clamp, and supporting base and bushing with various modifications available for special types of sealing.

INTERLOCKED-ARMOR, NON-SHIELDED CABLE

RUBBER-COVERED- Refer to Figure 35 for general information concerning termination. For details, refer to Figure 33. Note that rubber covered cable requires taping only near the terminal and not back to the terminator fitting.

VARNISHED-CAMBRIC- Refer to Figure 35 for general information concerning termination. Note that varnished-cambric cable requires taping back to the terminator fitting since the individual conductors or "singles" have no braid. See Figure 34.

INTERLOCKED-ARMOR, SHIELDED CABLE

Interlocked-armor, rubber-covered, and varnished-cambric insulated cables are sometimes shielded at ratings of 5kV and below. If they should be, proceed to terminate as detailed for other types of shielded cables. Refer to Figure 36.

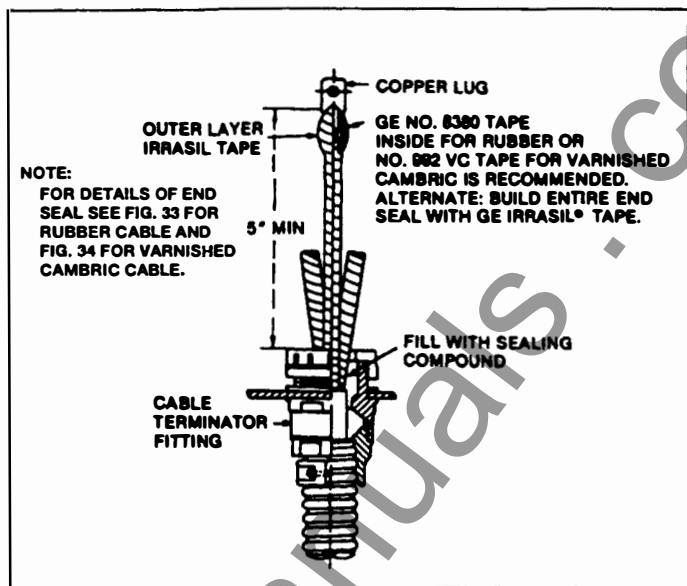

Figure 35. Termination of interlocked-armor, non-shielded, 5000-volt cable

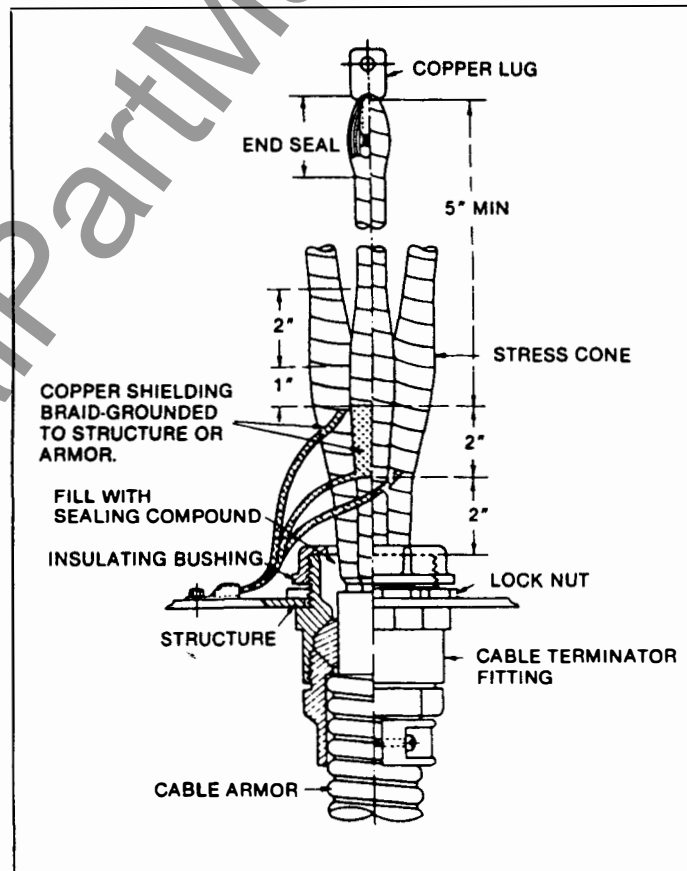

Figure 36. Termination of interlocked-armor, shielded, 5000-volt cable

TERMINATION OF SHIELDED CABLE

It is recommended that when shielded cable is used, "stress-relief cones" be built up at the cable terminations, or else GE Termi-Matic® stress cones or similar kits be used as shown in Figures 37 and 38. This will relieve the electrical stress which occurs in the area around the termination of the ground shield. When making shielded cable terminations to Limitamp®, the following procedure is recommended:

Use GE Termi-Matic® or similar system per Figure 38, or build stress cones with tape as follows:

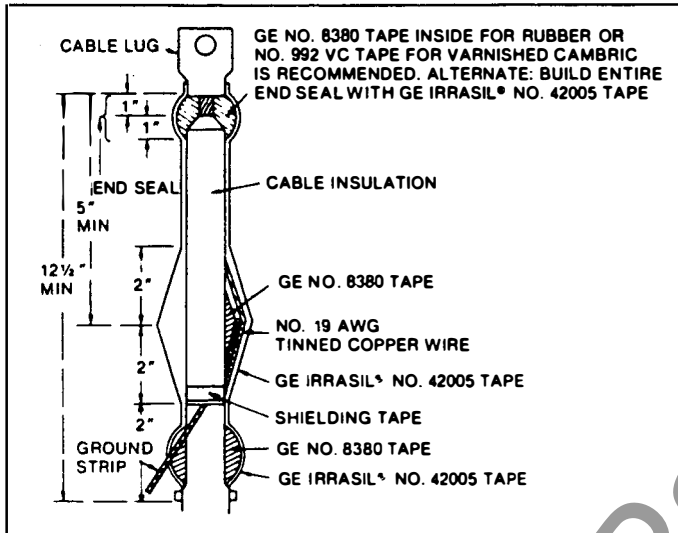

Figure 37. Termination of shielded, 5000-volt cable showing stress cone construction

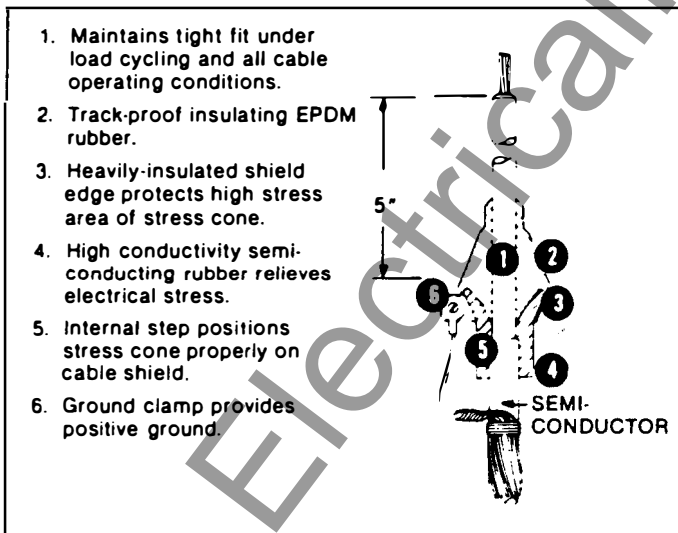

Figure 38. TERMI-MATIC® preformed stress cones (5 kV)

Step 1.

Mark the cable at least 10 inches from the terminal point.

Step 2.

Remove all shielding from the terminal end to this point, leaving sufficient ground strip to reach the nearest ground connection.

Step 3.

Proceed to build stress cones as prescribed by the cable manufacturer. Refer to Figures 36 and 37 for details.

Step 4.

Tie all of the ground strips together and fasten them to the ground bus link or ground bus.

If the preceding recommendations, along with the cable manufacturer's recommendations, are followed, the cable terminations should be satisfactory and reliable. These instructions apply to both rubber-covered and varnished-cambric insulated shielded cables.

Control Connections

Conduit for control wires should be brought into Limitamp® enclosures at the locations shown in the Outline Detail section of the drawings provided with the equipment. If the control wire is entering a CR194 two-high enclosure, these incoming control conduit locations are shown in Figure 50, and removable conduit cutout covers are provided in both top & bottom (if a bottom is provided). These covers are shown in Figure 30. Figure 2 shows the two-high with both low-voltage doors open, and shows the low-voltage terminal boards on the left portion of the low-voltage area. There is a 2-inch hole on the left in the area between the upper & lower starters that allows passage of low-voltage wires between the starters. Normally this hole will be plugged at the factory, with the customer having the option of unplugging and using the hole for low-voltage wires if needed. Customer's low-voltage wiring will normally be confined to the left, front area of each two-high starter.

Mechanical Operation Check

ISOLATION SWITCH HANDLE TO CONTACTOR MECHANICAL INTERLOCK

The CR194 two-high vacuum Limitamp® is equipped with a quick-make, quick-break isolation switch in each starter for isolating the power bus when the switch handle is in the "OFF" position. This isolation switch is not designed to make or break motor load current. To insure that the isolation switch handle cannot be operated when the contactor is energized, a mechanical interlock mechanism is provided between the contactor and the isolation switch handle. Operation of this mechanical interlock for each starter should be checked per the following procedure.

WARNING: Confirm that equipment is de-energized before performing this check.

Step 1.

With the high-voltage door open, push in the door operated release pin as shown in Figure 39. This is not a normal operation and should only be used for equipment check out or servicing.

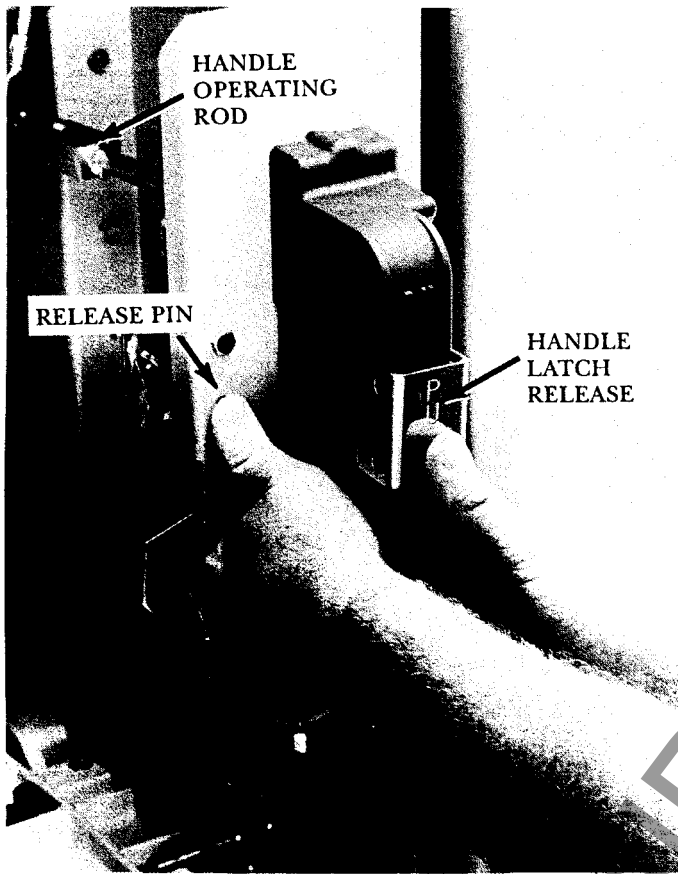

Figure 39. Isolation switch handle operation during equipment checkout

Step 2.

Push in the handle latch release shown in Figure 39 and begin to pull up on the handle. With the handle in the intermediate position, push down on the top moving armature of the contactor. The mechanical interlock mechanism should prevent the armature from fully closing on the contactor.

Step 3.

Release the pressure on the contactor armature and move the isolation switch handle to the full "ON" position (i.e. the handle latch release pops back out).

Step 4.

Push down on the top of the contactor moving armature and hold it down. The armature should close fully as if it were energized. Now attempt to press the handle latch release. The mechanical interlock should prevent the handle release from going in and you should be unable to move the isolation switch handle.

Step 5.

Release the pressure on the contactor armature and operate the isolation switch handle to the full "OFF" position (i.e. the handle latch release pops back out).

Step 6.

If the mechanism fails to meet any of the above checks, an adjustment must be made to the interlock assembly as detailed below and shown in Figure 40.

WARNING: Before making any adjustments, be sure that equipment is de-energized, the contactor is in the full "OPEN" position and the isolation switch handle is in an intermediate position with the handle latch release (Figure 39) fully depressed.

- A. Loosen the bottom locking nut (X), Figure 40, while holding the top adjusting nut (W) firmly in position. Also loosen the two retaining nuts at the top of the armature interlock rod (Y).
- B. Turn the top adjusting nut (W) until the interlock slider is just slightly below the handle latch release pusher rod (0.12 inches). See Figure 42 for location of pusher rod.
- C. When the proper position has been reached, hold the top adjusting nut (W) and tighten the bottom locking nut (X) to hold the adjustment. Finally, tighten the two locking nuts at the top of the armature interlock rod (Y).
- D. Test the interlock again by following Steps 1 through 6 above.

Step 7.

Return the isolation switch handle to the "OFF" position.

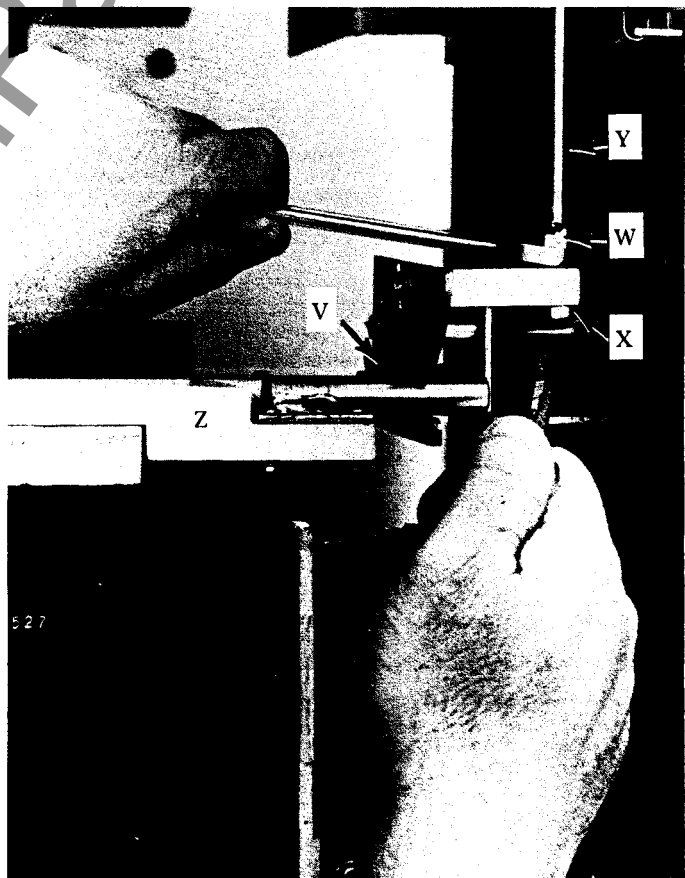

Figure 40. Adjusting the interlock mechanism
 V—Contactor to pawl engagement
 W—Top adjusting nut
 X—Bottom locking nut
 Y—Armature interlock rod
 Z—Contactor armature

HANDLE AND ISOLATION SWITCH OPERATION

WARNING: Confirm that equipment is de-energized before performing this check.

Step 1.

With the high-voltage door open, push in the door operated release pin as shown in Figure 39. This is not a normal operation and should only be used for equipment check out or servicing.

Step 2.

Push in the handle latch release (See Figure 39) and move the handle up to the full "ON" position (i.e. the handle latch release pops back out) by rotating the handle up with a rapid, positive motion.

Step 3.

The isolation switch contacts may be viewed by looking through the window supplied in the main fixed barrier (See Figure 10). The contacts should be fully seated on all three phases, and the word "ON" should be visible in three places on the rotating shaft.

Step 4.

Push in the handle latch release (See Figure 39) and move the handle down to the full "OFF" position (i.e. the handle latch release pops back out) by rotating the handle down with a rapid, positive motion.

Step 5.

By looking through the window on the main fixed barrier, confirm that the isolation switch contacts are fully open, as indicated by being able to read the word "OFF" in three places on the movable contact molding. See Figure 11.

HIGH-VOLTAGE DOOR SAFETY INTERLOCK

WARNING: Confirm that equipment is de-energized before performing this check.

The operation of the high-voltage door safety interlock should be checked per the procedure shown in Figure 41.

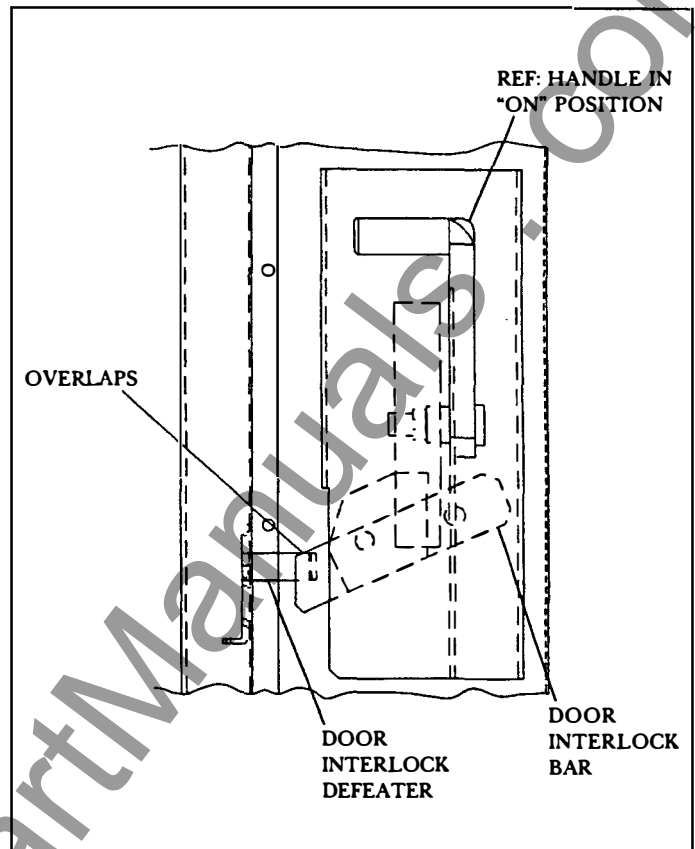

WARNING:
ALL POWER MUST BE REMOVED FROM THE CONTROLLER BEFORE MAKING THIS CHECK

TO CHECK FOR PROPER INTERLOCKING BETWEEN THE HIGH-VOLTAGE DOOR AND THE DOOR SAFETY INTERLOCK, THE FOLLOWING CHECK SHOULD BE MADE:

- A. OPEN HIGH VOLTAGE DOOR
- B. WITH THE DOOR OPEN, CLOSE THE ISOLATION SWITCH AS SHOWN IN FIG. 39
- C. CLOSE THE DOOR AGAINST THE DOOR INTERLOCK BAR
- D. LOOK THROUGH THE HANDLE CUTOUT IN THE DOOR AND VISUALLY DETERMINE THERE IS AN OVERLAP BETWEEN THE DOOR INTERLOCK DEFEATER AND THE DOOR INTERLOCK BAR AS SHOWN IN THIS FIGURE
- E. FOR FINAL CHECK, OPEN THE ISOLATION SWITCH, CLOSE THE HIGH-VOLTAGE DOOR, RE-CLOSE THE ISOLATION SWITCH, AND TRY TO PULL THE DOOR OPEN. THE DOOR SHOULD NOT OPEN.

Figure 41. Checking procedure for high-voltage door safety interlock

www.ElectricalPartManuals.com



CONTROL POWER INTERLOCK (CPI)

WARNING: Confirm that equipment is de-energized before performing this check.

Check the CPI adjustments as shown in Figure 42 and adjust if required.

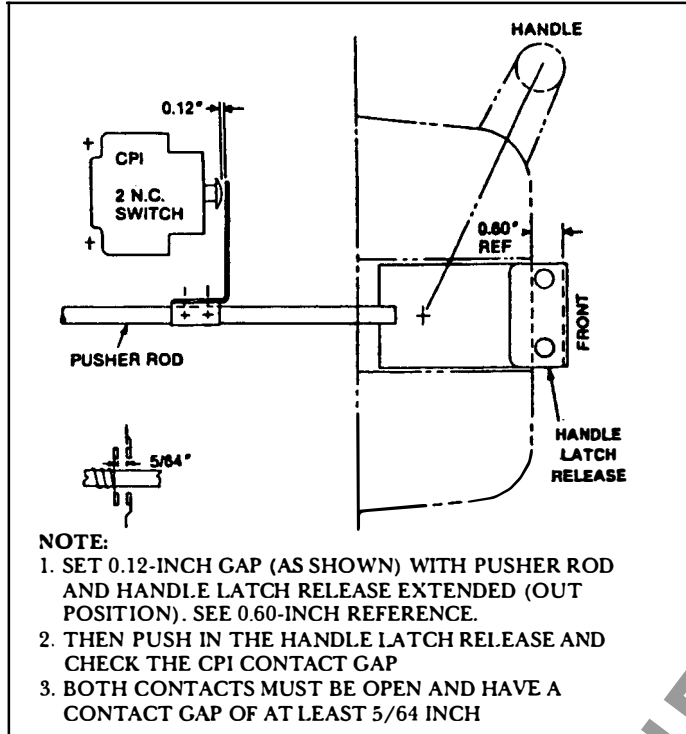

Figure 42. Checking for proper operation of pusher rod and control power interlock (CPI)

TEST POWER INTERLOCK (TPI)

Check the TPI adjustments as shown in Figure 43 and adjust if required.

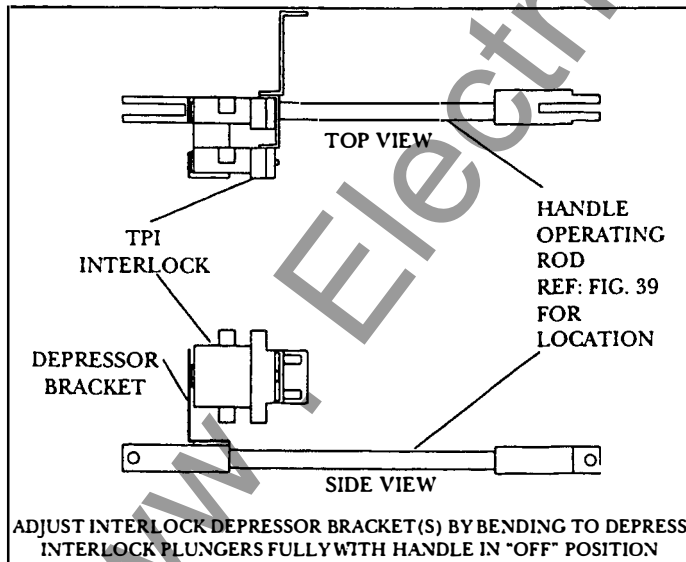

Figure 43. Checking test power interlock (TPI) adjustment

NOTE: If the controller fails to meet any of the above Mechanical Operation Checks, DO NOT ENERGIZE THE CONTROLLER. Contact your nearest GE sales office.

Vacuum Interrupter Integrity Test

WARNING: The vacuum interrupter integrity test should be performed before the high-voltage contactor is energized for the first time and each time it is returned to service after maintenance, adjustment or repair (See GEH-5306). Otherwise the vacuum interrupter integrity test should be performed annually. Failure to perform this test may cause serious injury or death.

WARNING: All barriers must be in place and the isolation switch handle must be in the "OFF" (down) position (i.e. the handle latch release pops back out) before attempting to perform the vacuum interrupter integrity test.

WARNING: This high-voltage test is potentially hazardous, so extreme caution should be exercised. First open the controller isolator switch, then completely isolate the contactor by disconnecting the contactor line side cables and load side bolts and sliding the contactor to the "intermediate" position using the safety stop.

WARNING: X-Ray emission may be produced if an abnormally high voltage is applied across the open contacts of a vacuum interrupter. Do not apply an RMS voltage across the contactor that is higher than 20.0 kV RMS.

NOTE: Before performing this vacuum integrity test, confirm that both the armature gap setting and contact wear adjustment are proper (See GEH-5306, Sections 5&6).

GENERAL

This test determines the internal dielectric condition and vacuum integrity of the vacuum interrupters. Prior to performing this test, the outside surfaces of the vacuum interrupters should be wiped clean of any contaminants with a non-linting cloth or industrial type wiper. During this test, each interrupter should be checked separately.

High potential test instruments can be purchased to perform the vacuum interrupter integrity test. The following is a recommended test instrument:

Hipotronics Model 7BT60A

Use of a DC Hipot is not recommended because results may indicate a problem with a good interrupter. If you wish to use a DC Hipot, set for 28 kV, but if an interrupter fails, confirm the failed interrupter using above AC Hipot.

TEST PROCEDURE

Step 1.

Move the isolation switch handle to the “OFF” position.

Step 2.

Open the high-voltage door.

Step 3.

For stationary contactors, remove the three load side connection bolts at the bottom, front of the contactor (do not loosen the R.T.V. covered bolts). Then remove the three line side cable bolts at the bottom of the power fuse assembly.

Step 4.

For drawout contactors, remove the two positioning bolts on the front of the contactor.

Step 5.

Slide the contactor forward approximately four (4) inches until the slide safety stop engages in the plate that is attached to the bottom of the contactor. Insure that the line side cables on the stationary contactors are sufficiently electrically isolated.

Step 6.

With the contactor in the open position, connect the test leads to the contactor power terminals as shown in Figure 44. Apply 20.0 kV RMS and hold for a minimum of five seconds.

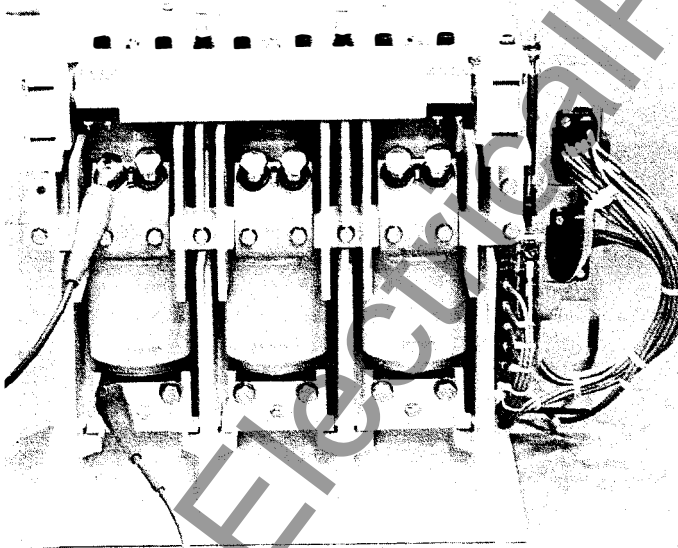

Figure 44. Method of connecting test leads to interrupter for vacuum integrity test (stationary contactor shown)

Step 7.

Reverse the leads and repeat the test.

Step 8.

If no breakdown occurs, the interrupter is in acceptable condition. If a breakdown occurs, the interrupter should be replaced. Refer to “Interrupter Replacement” section in GEH-5306.

NOTE: No attempt should be made to compare the condition of one vacuum interrupter with another nor to correlate the condition of any interrupter to low values of DC leakage current. There is no significant correlation.

Step 9.

After the high potential voltage is removed from the interrupters, the metal end caps of the interrupters should be discharged with a grounding stick to remove any residual electrical charge.

Step 10.

Reverse the above procedure to return the equipment to the original starting condition. For stationary contactors, torque the line side cable bolts at the bottom of the power fuse assembly to 9 ft-lb and torque the load side bolts at the bottom front of the contactor to 16 ft-lb.

WARNING: Be absolutely certain that these bolts are properly installed and torqued. These are current carrying connections and must be tight or damage will result.

Preparation of Controller for Operation

Clean the inside of the equipment with a brush, soft cloth, or dry compressed air. Make certain that any dirt, dust or bits of packing material which may interfere with successful operation of the panel devices are removed from the panel.

CAUTION: Care should be taken during the cleaning operation to prevent any dirt from being blown into the inaccessible spaces of the enclosure or the devices.

Check to confirm that no tools or loose wires have been left in the panel during the installation process.

Operate relays, contactors, push-buttons, selector switches, etc. by hand to see that the moving parts operate freely and without binding.

Consult the drawings supplied with the equipment to confirm that all the external low-voltage control connections have been made, and that protective and control relays are set properly for the equipment being controlled.

Do a visual inspection of all devices and connections. The controller is now ready for megger check.

Megger Check

WARNING: Confirm that equipment is de-energized before performing this check.

With all power removed from the equipment and the isolation switch handle “OFF”, megger the motor terminals between each phase and ground link. Also megger the main bus bars between each phase and ground bus.

OPERATION

CAUTION: Before proceeding with operation of the equipment, insure that at this time the equipment is still de-energized, that the isolation switch handle is in the “OFF” (down) position (i.e. the handle latch release pops back out), that the equipment has passed the above Mechanical Operation Check, Vacuum Interrupter Integrity Test and Megger Check in their entirety, and that all barriers are in place.

Operation Under Test Power

A complete electrical operation check of each controller can be made without energizing the main incoming power bus by using the standard test power circuit. A wiring diagram that shows this test power circuit and associated connection is included with the controller when it is shipped from the factory. The customer should connect his test power to the test power terminals typically labeled “Purchaser’s Test Power”. The controller should be put through its complete operating sequence, in the test position, as a final check before energizing the power bus.

The test power circuit is composed of a test power interlock (TPI), which is shown in Figure 45, and a Test-Normal selector switch (TSW), shown in Figure 7. When the isolation switch operating handle is “off”, the TPI interlock assembly is depressed and one of the TPI interlocks opens the secondary circuit of the control power transformer, thereby electrically isolating it. The TPI and TSW contacts are arranged in the circuit so that the TSW switch must be in the “Test” position and the isolation switch handle must be in the “off” position in order for the test power circuit to function. By the same token, the TSW switch must be in the “Normal” position and the isolation switch handle must be in the “on” position for normal bus-powered operation.

Refer to the wiring diagrams provided with the equipment to determine the necessary test voltage and frequency.

Normal Operation

Step 1.

Upon completion of the above items under “Operation”, the equipment is now ready for energization.

Step 2.

Close the compartment doors and apply power to the controller.

NOTE: If the operating handle of the isolation switch cannot be moved to the “ON” position, it may be that the mechanical interlock device is preventing this movement. To move the handle to the “ON” position, the high-voltage door must be fully closed and the contactor must be open.

Step 3.

Move the isolation switch handle to the full “ON” position by moving the handle with a rapid, positive motion to the extreme up position (i.e. the handle latch release pops back out).

Step 4.

Operate the controller in the normal manner with the pilot devices (usually push buttons) provided to check the motor for proper rotation.

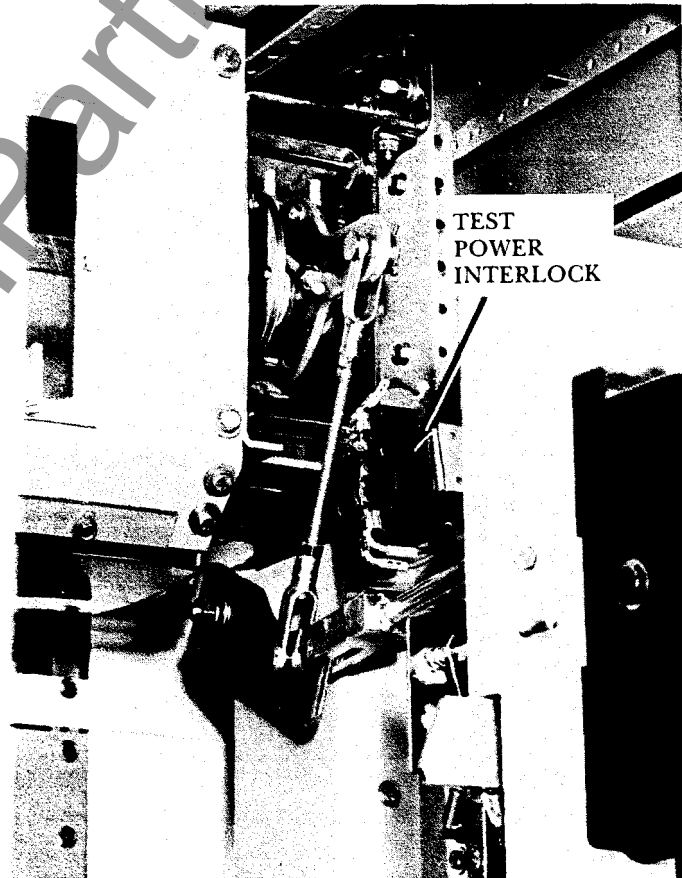

Figure 45. Test power interlock (TPI)

Normal High-Voltage Door Opening Procedure

To open the high-voltage door to gain access to the contactor or motor terminals, the contactor must be in the de-energized position. If the contactor is energized, the latch release on the isolation switch handle cannot be pushed in, the handle cannot be operated, and the door can't be opened.

Depressing the Stop button de-energizes the contactor. The latch release on the isolation switch handle can then be depressed, which opens an electrical interlock (control power interlock, or CPI) in the secondary of the control power transformer. When the latch release has been depressed, the isolation switch handle may be moved to the full "OFF" position by moving the handle with a rapid, positive motion to the extreme down position (i.e. the handle latch release pops back out). When the isolation switch handle is in the "OFF" (down) position, the high-voltage door may be opened by turning the two latch bolts.

High-Voltage Door Defeater Latch

WARNING: The following steps should be taken only as a last resort to enter a malfunctioning controller. It is imperative that all power to the main bus be removed before proceeding.

IN CASE OF EMERGENCY, remove all power to the controller, then the high-voltage door may be opened with the contactor in the closed position and with the isolation switch closed, by following the procedure listed below.

WARNING: Do not proceed unless all power to the controller is removed. In this situation, doors must not be opened with power connected to the bus.

Step 1.

Loosen the two high-voltage door latch bolts as shown in Figure 46.

Step 2.

Turn the two 1/4 turn latches on the low-voltage door and open the low-voltage door.

Step 3.

Once the low-voltage door is open, the defeater mechanism can be located in the lower right corner of the low-voltage compartment.

Step 4.

Remove the door interlock defeater locking bolt as shown in Figure 47.

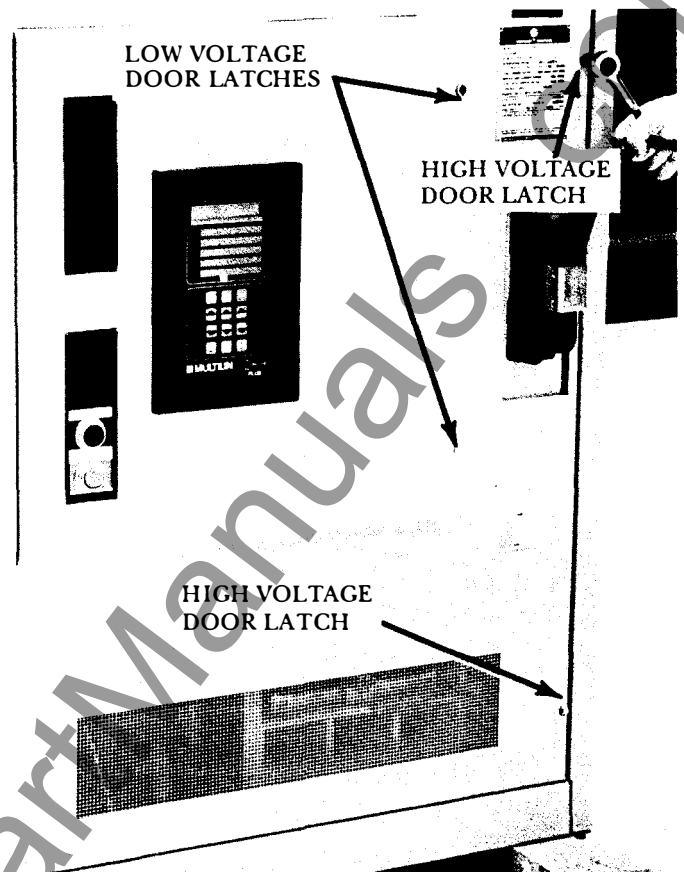

Figure 46. View showing door latch hardware

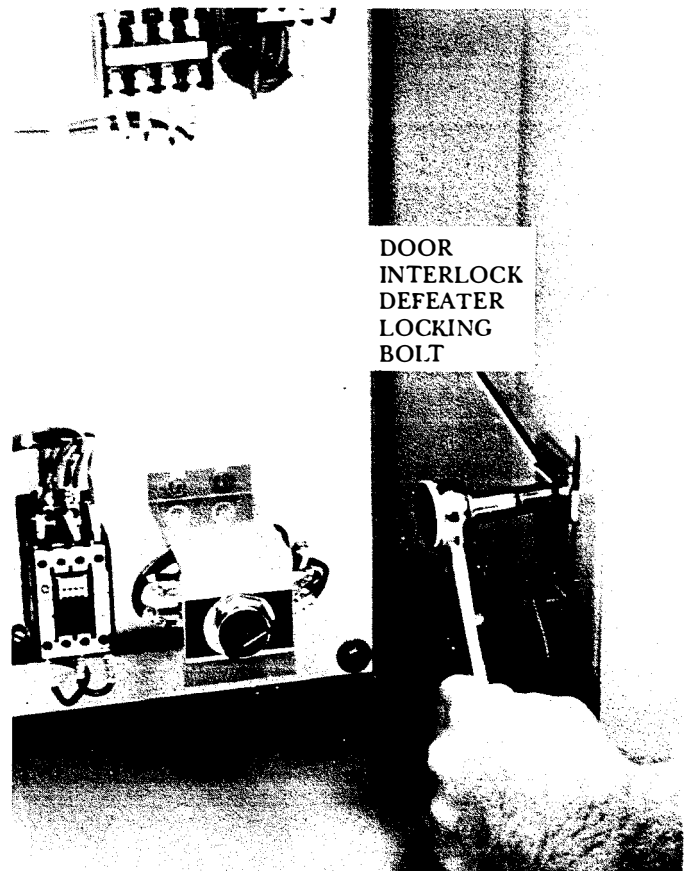

Figure 47. Interior view of low-voltage compartment showing door interlock defeater



Step 5.

While pulling on the high-voltage door, lift up on the defearer bracket as shown in Figure 48 to allow the high-voltage door to open.

WARNING: Defeating the high-voltage door interlock leaves the power fuses & contactor connected to the bus. The bus power must stay removed with the high-voltage door interlock defeated.

**INSPECTION,
MAINTENANCE & SERVICING**

WARNING: Before performing any inspection, maintenance or servicing on the equipment all power must be removed from the equipment and all load-connected rotating equipment must have come to a complete stop.

Mechanical Operation Check

Begin any inspection, maintenance and servicing routine by first performing all the checks in the “Mechanical Operation Check” section, which is part of the “Installation” section of this instruction. This includes:

- Isolation Switch Handle to Contactor Mechanical Interlock
- Handle and Isolation Switch Operation
- High-Voltage Door Safety Interlock
- Control Power Interlock (CPI)
- Test Power Interlock (TPI)

Vacuum Interrupter Integrity Test

Then perform the “Vacuum Interrupter Integrity Test”, which is a part of the “Installation” section of this instruction.

Vacuum Contactor

Complete maintenance and adjustment instructions for the high-voltage contactor are presented in GEH-5306. Refer to that instruction for all problems of servicing and adjusting the contactor and to the proper renewal parts bulletin for renewal parts for the contactor.

Contactor tip life depends on the severity of the service, but in any case, it is recommended that the contactor tip wear be checked at least once a year, or in very high duty cycle situations, after every 250,000 operations.

Isolation Mechanism

WARNING: Under no circumstances should the isolation switch be inspected or adjusted with power applied to the main bus.

The quick-make, quick-break isolation switch assembly is adjusted and tested at the factory and under normal circumstances does not need adjustment. However, if conditions require, the switch can be adjusted in the field by following the steps below.

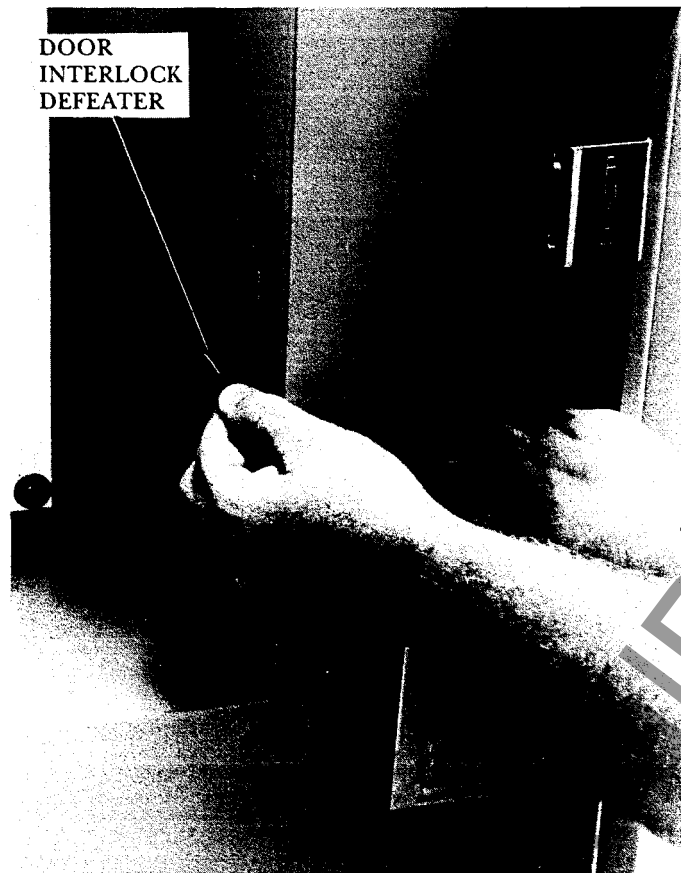

Figure 48. Lift defearer bracket while pulling high-voltage door

Step 6.

To close the high-voltage door with the isolation switch handle in the “on” position, the procedure must be done in reverse order, making sure to reinstall the door interlock defearer locking bolt.

WARNING: All power must be removed from the main bus before attempting to adjust the isolation switch mechanism.

To adjust the isolation switch blade pressure, follow the steps below:

Step 1.

With the high-voltage door open, push in the door operated release pin as shown in Figure 39. This is not a normal operation and should only be used for equipment check out or servicing.

Step 2.

Push in the handle latch release (See Figure 39) and move the handle up to the "ON" position.

Step 3.

Remove the isolation switch barriers (Figure 49) by removing the retaining screws that hold these in place. Place the barriers aside, and retain the hardware for reassembly.

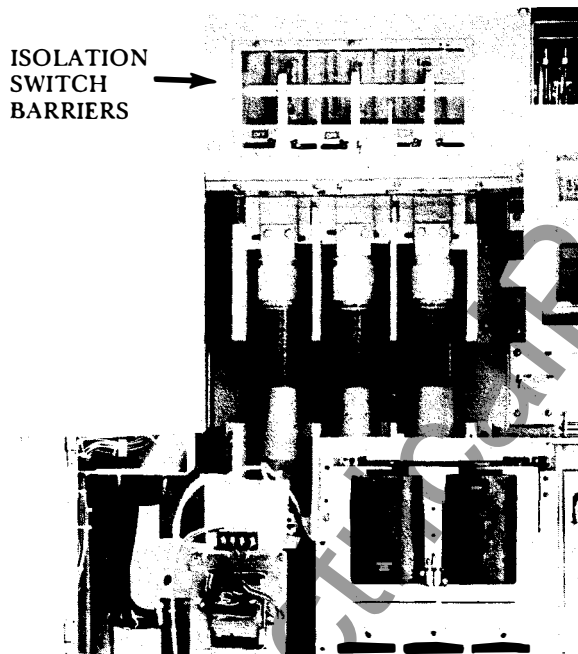

Figure 49. Isolation switch barriers to remove for switch adjustment

Step 4.

Near the top end of each switch blade assembly, a screw and adjusting nut are located along with a belleville type spring washer. To adjust the blade pressure, the nut must be adjusted. Loosen the small set screw located on each adjusting nut, then loosen the nut.

Step 5.

With your fingers, retighten the nut until all the slack is out between the blades, stationary contact, spring washer and nut, then tighten using a wrench an additional 1/8(one-eighth) turn. This procedure provides the necessary 0.005 inch spring compression of the blades.

Step 6.

Tighten the set screw on the nut to lock the adjustment in position. Use caution to prevent turning the nut while tightening the set screw.

Step 7.

When the isolation switch blade adjustment is complete for all three phases, return the isolation switch handle to the "OFF" position, then apply a thin coating of Mobil Temp SHC-32 grease to the contact surfaces of the male stab portion of the disconnect.

If adjustment of the pivot point belleville type spring washers are not planned, the adjustment procedure is complete, so proceed to Step 6 below.

To adjust the pivot point belleville type spring washers, follow the steps below:

WARNING: All power must be removed from the main bus before attempting to adjust the isolation switch mechanism.

Step 1.

Close the isolation switch by following Steps 1 & 2 above.

Step 2.

On each phase, loosen the set screw on the lower pivot point adjusting nut.

Step 3.

Loosen the adjusting nut and then retighten using your fingers until the nut is just snug and no side play of the parts is evident.

Step 4.

Using a wrench, tighten the adjusting nut an additional 1/2(one-half) turn and tighten the set screw to hold the adjustment in place.

Step 5.

Return the isolation switch to the "OFF" position.

Step 6.

Reinstall the isolation switch barriers. If necessary, the viewing window may be cleaned before reinstallation of the barrier. Use a soft cloth and a mild soap and water solution, or a mild commercial cleaner such as Windex®.

WARNING: At the conclusion of this procedure, insure that the isolation switch handle is in the "OFF" position and all barriers have been reinstalled.



Torque Recommendations For Electrical Power Connections

Bolt Size	SAE Grade 5 Bolt Torque (ft-lb)
¼-20	4
⅜-18	9
½-16	16
⅝-13	39

Preventive Maintenance Guide

WARNING: Before performing any inspection, maintenance or servicing on the equipment all power must be removed from the equipment and all load-connected rotating equipment must have come to a complete stop.

Maximum trouble free service from vacuum Limitamp® controllers requires periodic preventive maintenance, inspection and cleaning. A definite schedule should be maintained for each, with the frequency depending on the operating conditions.

When doing inspections, five basic categories of deteriorating influences should be kept in mind:

1. The effect of foreign material (i.e. dirt and dust from the environment such as wood fibers, coal dust, cement, lamp black, lint, etc.).
2. The effect of chemicals in the atmosphere (i.e. sulfur dioxide, chlorine, some hydrocarbons,

salt water, etc.).

3. Mechanical wear and fatigue on all moving parts.
4. Heat.
5. Loose joints and connections.

Follow directions in these instructions for obtaining access to all sections of the controller, including high-voltage door interlocking. Also, refer to GEH-5306 for directions relative to inspection of the high-voltage contactor.

The following are some specific recommendations:

1. Check for cleanliness generally, but particularly for accumulation of any foreign material on insulators. Voltage failures can result from tracking across insulation surfaces where they are dirty. The primary circuit insulation on the controller may be checked phase to phase and phase to ground using a 2500 volt megger.
2. Check for abrasive material accumulated in the isolation mechanism and mechanical interlock bearing and cam surfaces.
3. Check for buildup of dust and dirt which would reduce any air or surface voltage clearances.
4. Excessive heat can cause wire and cable insulation breakdown. Therefore, check for any evidence of melting, discoloring, deterioration, etc. of wire and cable.
5. The isolation mechanism has a life expectancy of approximately 6000 operations. If the application is such that the mechanism is operated more than twice each day, then the mechanism should be checked at the end of each 1000 operations. Otherwise a yearly inspection is recommended.
6. Periodic checks of dimensions of the isolation mechanism and mechanical interlocks is strongly recommended. Follow the sections in these instructions titled Mechanical Operation Check and Isolation Mechanism.
7. When any part of the isolation mechanism or mechanical interlocking is replaced, all dimensions and checking procedures referred to in Step 6 above should be followed to be sure the system is normal working order.

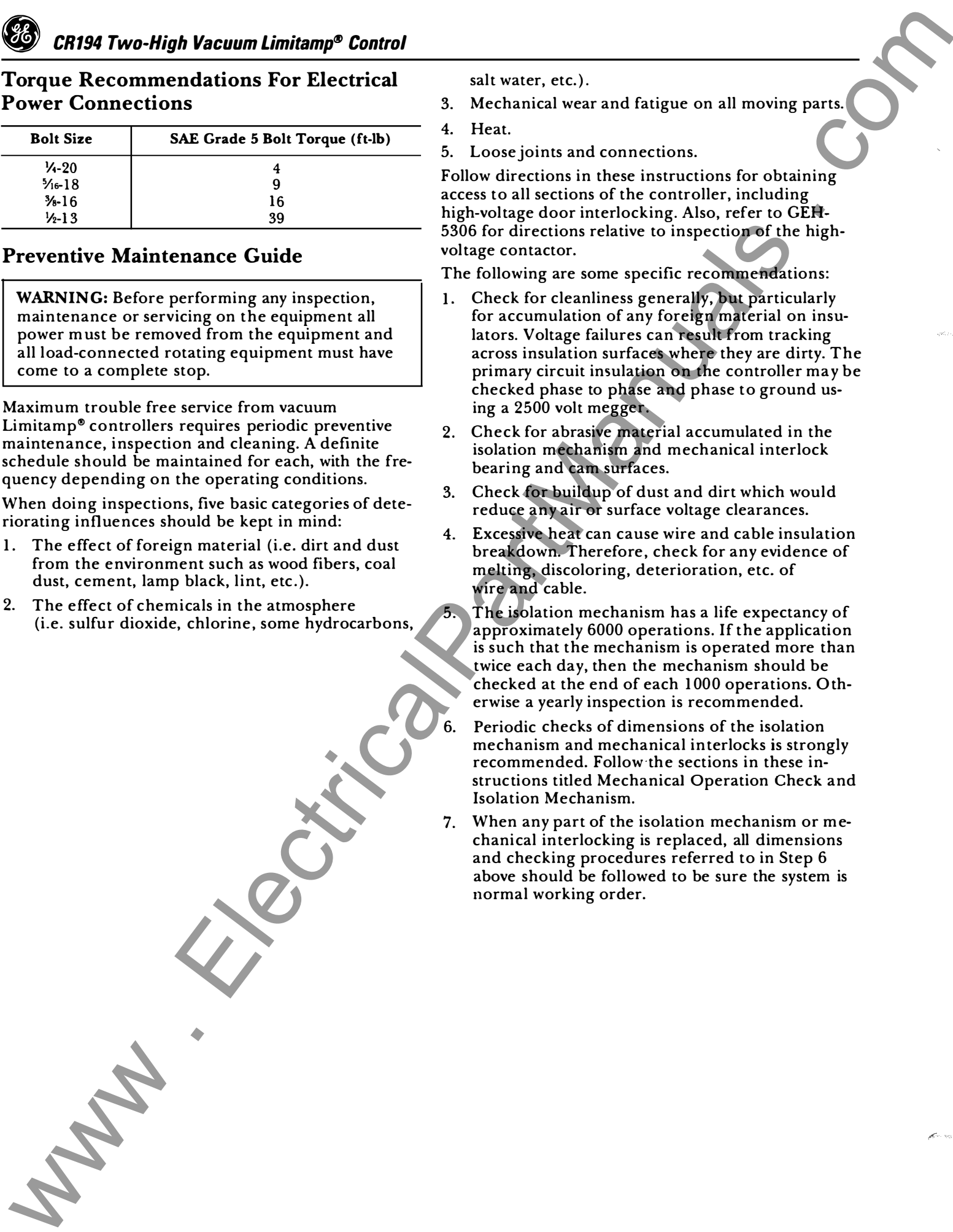

NOTES

- B1 - AC POWER BUS
- C - CONTROL LEAD TERMINAL BOARD
- D - MOTOR LEAD TERMINAL CONNECTION
- G - SPACE REQUIRED TO OPEN DOORS 90 DEGREES
- H - AISLE FOR CONTACTOR REMOVAL
- J - MOUNTING HOLES FOR 1/2 IN. DIA. ANCHOR BOLTS
- M - RECOMMENDED POSITION FOR INCOMING MOTOR CONDUIT
- N - RECOMMENDED POSITION FOR INCOMING CONTROL CONDUIT
- Y - GROUND BUS

⊗ - INDICATES TERMINAL LOCATION - APPROX. FOR CABLE LENGTH

Δ - APPROXIMATE WEIGHT

36"-Wide Enclosure

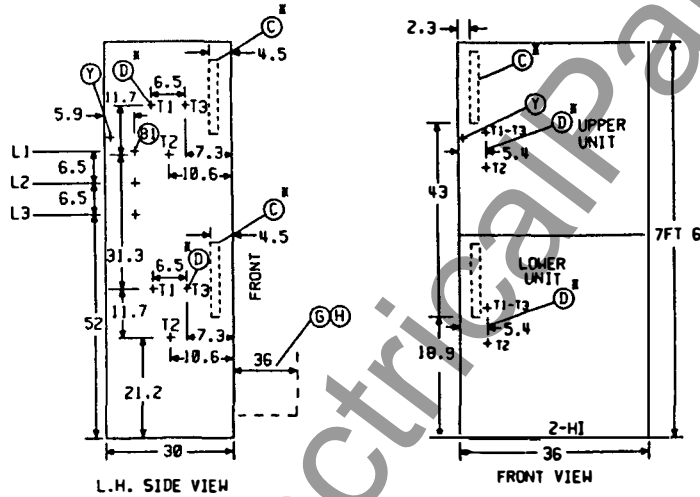

Δ - 2000 #

40"-Wide Enclosure

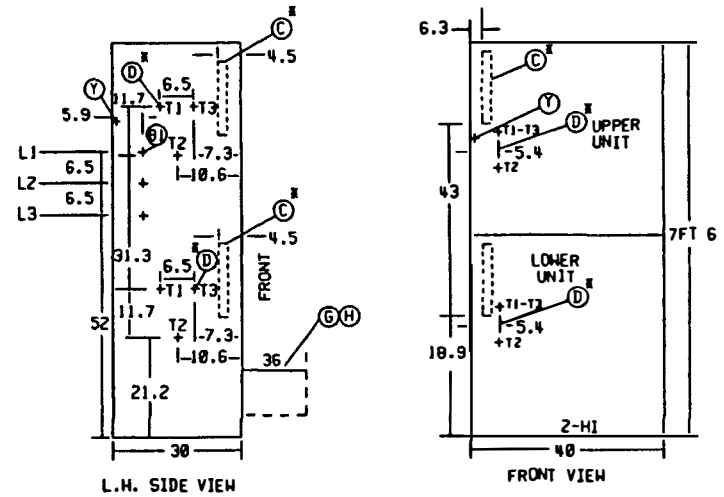

Δ - 2000 #

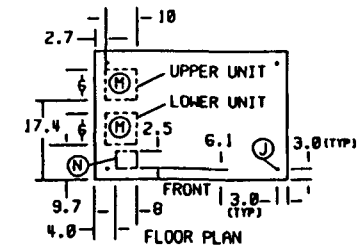
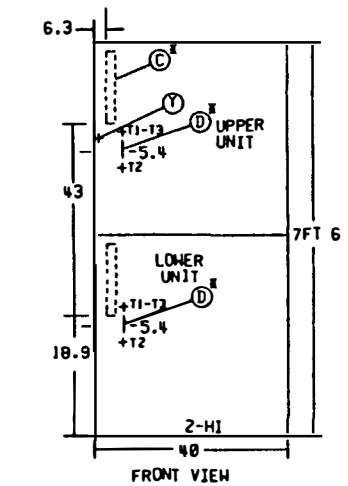
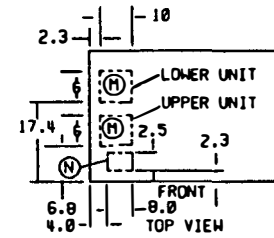
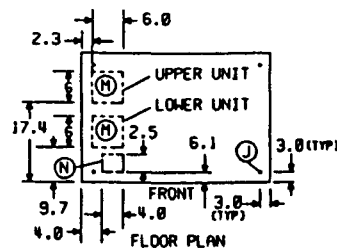
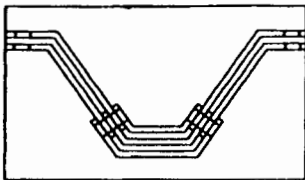

Figure 50. Enclosure details

CR194 2HI VAC TO
CR194 2HI VAC
2000A MAIN BUS

G1 •



CR194 2HI VAC TO
CR194, CR7160 1HI
2000A MAIN BUS

G3 •

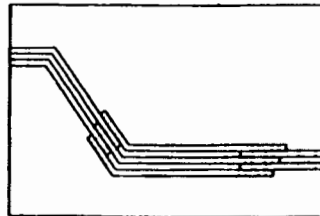

CR194 2HI VAC TO
CR7160 2/3 HI
2000A MAIN BUS

G5 •

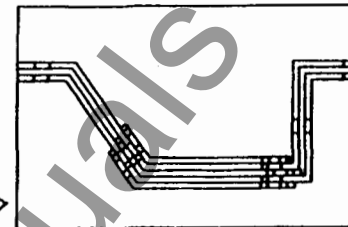

CR194 2HI VAC TO
CR194 2HI VAC
1200A MAIN BUS

G2 •

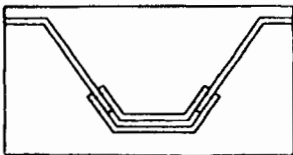

CR194 2HI VAC TO
CR194, (1200A) 1HI,
CR7160 (1000A) 1HI,
MAIN BUS

G4 •

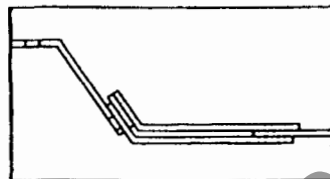

CR194 2HI VAC TO
CR7160 2/3 HI
1000A MAIN BUS

G6 •

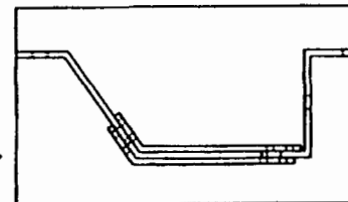

CR194 2HI VAC TO
CR194 2 HI VAC
GROUND BUS

G7 •

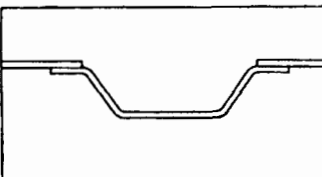

CR194 2HI VAC TO
CR7160 2/3 HI
GROUND BUS

G9 •



CR194 2HI VAC TO
CR194, CR7160 1 HI
GROUND BUS

G8 •

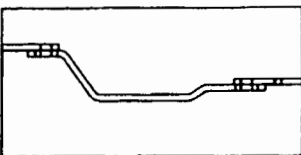

GROUND BUS GROUPS ONLY

• ADD SUFFIX LETTERS TO MATCH REQUIREMENTS FOR THE JOB

SUFFIX LETTERS	PLATING TYPE	
N6	NONE	600A GND. BUS
T6	TIN	.250 THK
S6	SILVER	
N4	NONE	400A GND. BUS
T4	TIN	.125 THK
S4	SILVER	

Example: 55B534911G4N

MAIN BUS GROUPS ONLY

• ADD SUFFIX LETTER TO MATCH REQUIREMENTS FOR THE JOB

SUFFIX LETTER	PLATING TYPE
N	NONE
T	TIN
S	SILVER

BUS SPICES FOR MAIN BUS MUST BE TAPED WITH 130C RUBBER SPLICING TAPE TO MAINTAIN ELECTRICAL CLEARANCES. SEE "TAPING INSTRUCTIONS FOR 5KV"

Figure 51. Splicing of main bus and ground bus

NOTES:

www.ElectricalPartManuals.com



NOTES:

www.ElectricalPartManuals.com

NOTES:

www.ElectricalPartManuals.com

www.ElectricalPartManuals.com

These instructions do not purport to cover all details or variations in equipment nor to provide for every possible contingency to be met in connection with installation operation or maintenance. Should further information be desired or should particular problems arise which are not covered sufficiently for the purchaser's purposes, the matter should be referred to the GE Company.



GE Electrical Distribution & Control