

INSTRUCTIONS



SYNCHRONOUS-MOTOR CONTROL

with

**IC3655A105 SOLID-STATE
STARTING AND PROTECTION MODULE**

IC3655A105 A3B045D

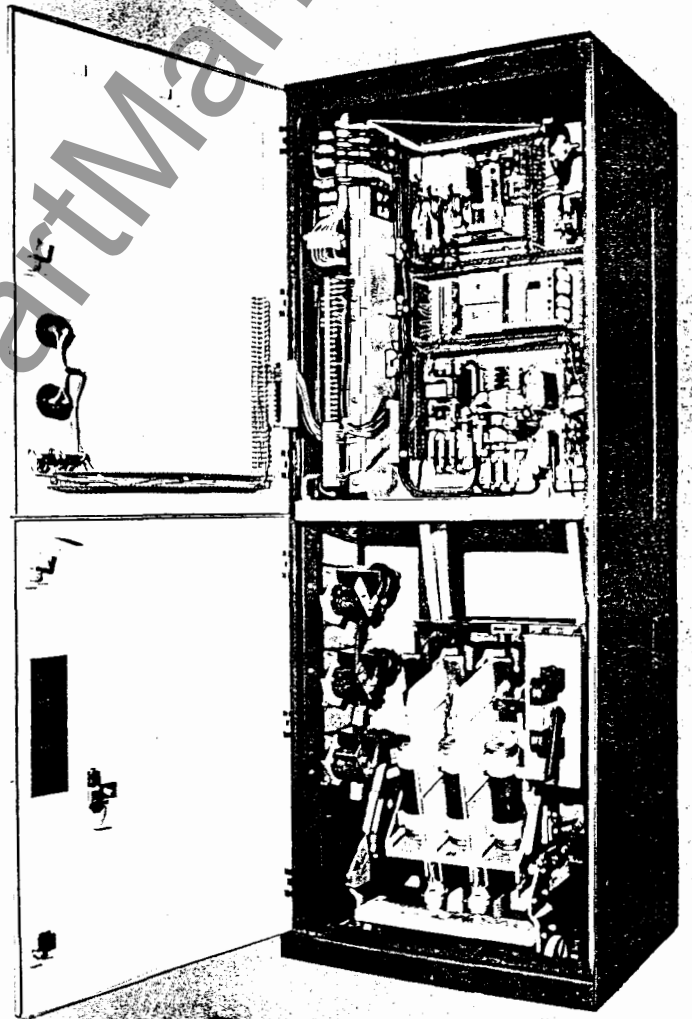
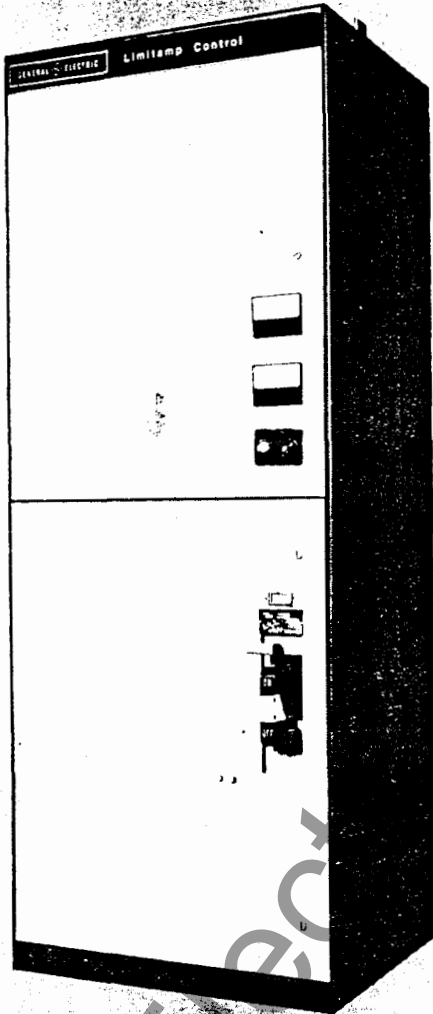

www.ElectricalPartManuals.com

NOTE: Before any adjustments, servicing, parts replacement or any other act is performed requiring physical contact with the electrical working components or wiring of this equipment, THE POWER SUPPLY MUST BE DISCONNECTED.

INTRODUCTION

These instructions apply to the various synchronous-motor starters, subassemblies and field panels supplied by the General Electric Company under the type designations listed below. It is the intent of these instructions to cover essential aspects of the complete synchronous-motor control system as it is conceived to function as a whole. Separate instructions covering partial assemblies or components are not included. If a complete starter is not supplied, the purchaser is requested to interpret these instructions for applicability to his particular assembly by referring to diagrams supplied with the equipment purchased.

Type Designation	Description
IC7160A127/128	Full-voltage starter, Limitamp [®] control type (5000V)
IC7160B127/128	Reduced-voltage starter, Limitamp control type (5000V)
IC7069A3	Field control assembly

When built-in solid-state excitation is included with the control, these instructions should be supplemented with either GEH-3089A (diode type) or GEH-3094A (SCR type).

I. STARTING SYNCHRONOUS MOTORS — GENERAL

Synchronous motors start as induction motors because they have cage bars built onto their rotors. A synchronous motor without a squirrel cage would have very little starting torque. The squirrel cage of synchronous motors is sometimes referred to as the damper winding, or amortisseur winding, and although its primary purpose is to develop torque at start and during acceleration, it also serves to dampen power oscillations while running at synchronous speed. This cage winding produces torque in relation to slip the same as an induction motor. No continuous cage torque is developed at synchronous speed.

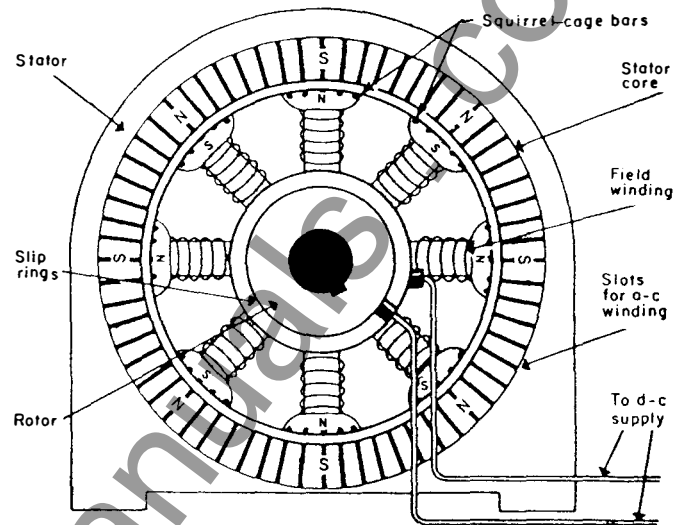

Fig. 1. Salient-pole synchronous motor

Torque at synchronous speed is largely derived from the magnetic field produced by the field coils on the rotor linking the rotating field produced by the currents in the armature windings on the stator.

In summary, a synchronous motor is basically a constant-speed motor that is started by a squirrel-cage winding and then locked "in-step" by a d-c current applied to the field winding. The motor is started as a squirrel-cage motor by a-c power. When the motor has reached synchronizing speed — approximately 95-percent synchronous speed — d-c current is introduced into the field windings in the rotor. This d-c current creates constant-polarity poles in the rotor which cause the motor to operate at synchronous speed.

Magnetic polarization of the rotor iron is due to physical shape and arrangement, plus constant potential direct current in coils looped around the circumference.

Synchronous motors, therefore, possess two general categories of torque characteristics. One characteristic is determined by the squirrel-cage design, which produces a torque in relation to "slip" (some speed below synchronous speed), and only in relation to slip since it can develop no torque unless there is slip. The other characteristic is determined by the flux in the salient field poles on the rotor as it runs at synchronous speed. The first characteristic is starting torque, while the second characteristic is usually referred to as synchronous torque.

www.ElectricalPartManuals.com

In the starting mode, the synchronous-motor salient poles are not excited by their external d-c source. If they were, there would be no useful torque developed by them. The reason for this is that the average torque due to field excitation during slip would be a negative or braking torque and hence would act to reduce the total amount of acceleration torque. In addition there is a very large oscillating component of torque at slip frequency produced by field excitation which could result in damage to the motor if full field current was applied during the whole starting sequence. Therefore, application of d-c to the field is usually delayed until the motor reaches a speed from which it can be pulled into synchronism without slip.

At synchronous speed, the unsymmetrical nature of the rotor produces a small torque (reluctance torque) which enables the motor to run at very light loads in synchronism without external excitation. Reluctance torque can also pull the motor into step if it is very lightly loaded and coupled to low inertia.

It is convenient to make an analogy of a synchronous motor to a current transformer for the purpose of demonstrating angular relationship of field current and flux with rotor position.

If I_1^* is an imaginary current in the stator causing the transformer action, then I_1 will be about 180 degrees from I_2 (or I_{FD}), and the flux will be 90 degrees behind I_{FD} . Very significantly, then, the point of maximum induced flux occurs as the induced field current I_{FD} passes through zero going from negative to positive; maximum rate of change of current.

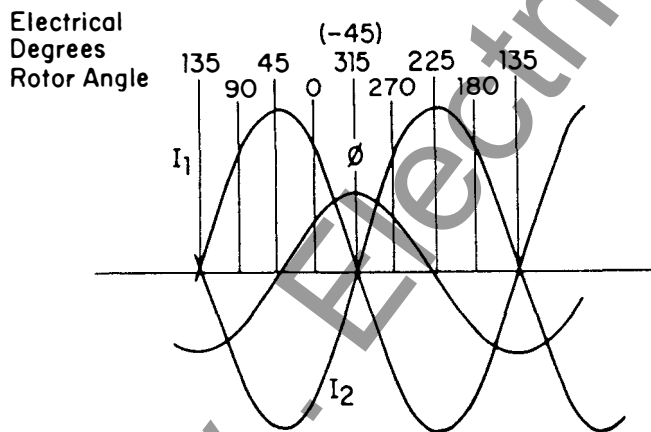

Fig. 2a. Transformer action of rotor flux and current (constant slip) for a typical motor

I_1 is not an actual current. The transformer action is due to stator flux (not shown) cutting the rotor winding.

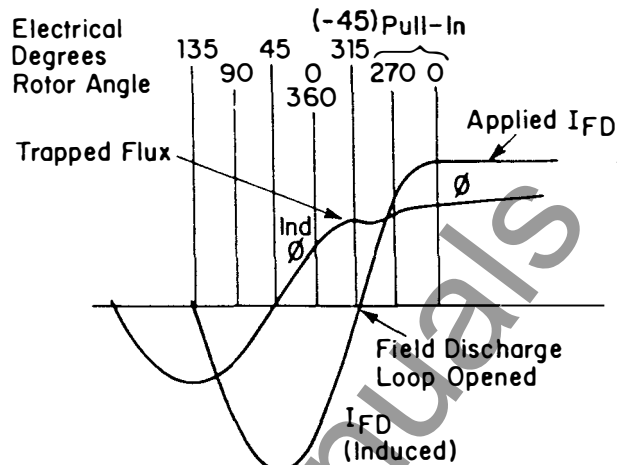
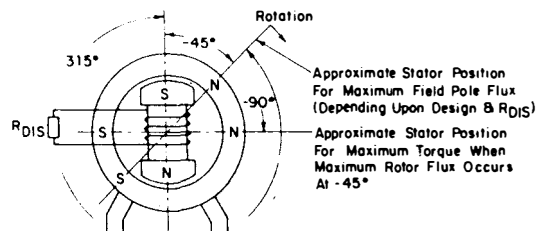

Fig. 2b. Rotor flux and current at pull-in (Typical design)

The rotor angle at which I_1 and I_2 go through zero will depend upon the ratio of reactance to resistance in the field circuit. A very high value of reactance to resistance will shift the angle toward -90 degrees. Reactance is high at low speed (high frequency). At high speed (low slip; low frequency) reactance decreases and the angle will shift toward 0 if the circuit includes a high value of resistance, but if the field is shorted (no resistance), very little shift will occur. As the stator goes beyond -45 degrees, torque increases (essentially due to increased stator flux). I_{FD} then gives us a very convenient indicator of maximum flux and increasing torque from which we may apply excitation for maximum effectiveness.

If the field discharge loop is opened at the point of maximum flux, then this flux is "trapped". Applying external amperes to the current path in correct polarity to increase this trapped flux at this instant then makes maximum use of its existence. Furthermore, the stator pole has just moved by and is in position to pull the rotor forward into synchronous alignment.



Note: Angular displacement of rotor with respect to stator is given a negative sign to indicate the motoring condition

Fig. 3.

www.ElectricalPartManuals.com

The criterion for satisfactorily pulling a synchronous motor into step is generally accepted to be the application of external field voltage at such speed and angle as to limit the pull-in period of the rotor to 180 electrical degrees. That is, there must not be a full slip cycle of the rotor after field is applied. There are many applications of motors, loads, and power systems on which and to which this criterion would be excessively demanding. It is not always necessary to meet this criterion. However, it is never harmful to meet it, and for many situations it is essential to meet it in order to have the motor pull-in at all, or to prevent detrimental effects upon the load and power system incident to several slip cycles with field applied.

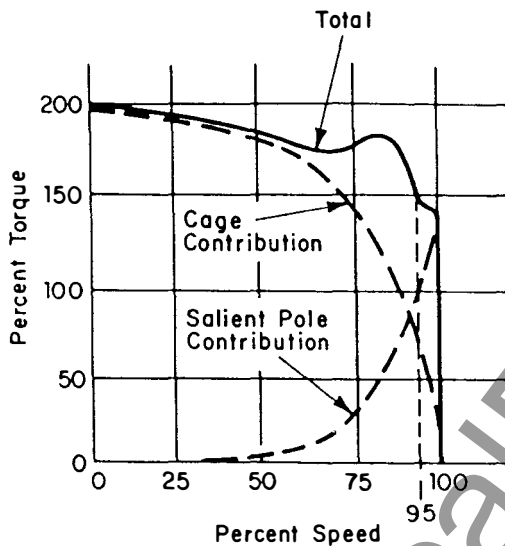

Fig. 4a. High-starting-torque motor

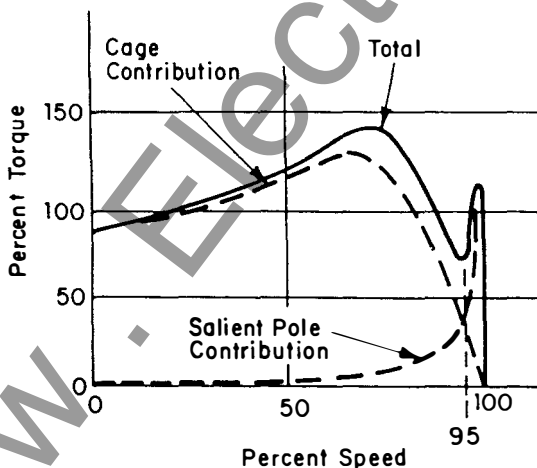

Fig. 4b. Medium-starting-torque motor

It has been established that salient pole torque near synchronous speed is a function of both slip and field discharge resistance. Fig. 4 shows the combined effects of cage torque and salient pole torque for a typical motor. Fig. 5 shows the effect of a higher value of discharge resistance on a medium torque motor. Obviously, without salient pole torque the motor would cease to accelerate certain loads at some point on the speed axis.

It may be asked, why not a high value of FDRS everytime. The answer is in the other function of the resistor, and that is to reduce field voltage to safe levels during starting. As the FDRS value increases, so does the induced voltage, and at some point this voltage would be damaging to insulation or other components in the field circuit. Solid-state excitation and control components in the field circuit have had the effect of making the value of FDRS and its voltage effect more significant. There is a greater sensitivity to field voltage tolerance levels with solid-state components.

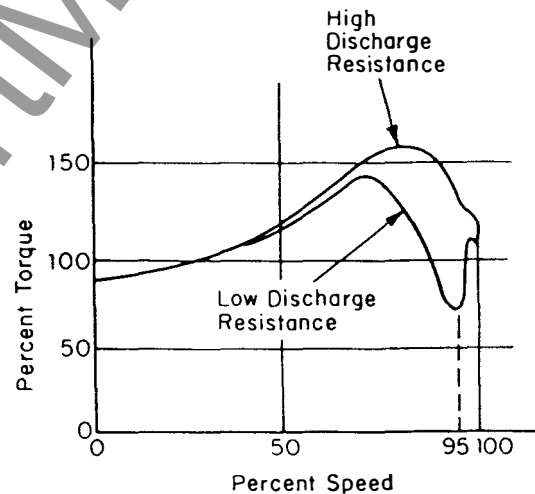

Fig. 5. Medium-starting-torque motor with two values of field discharge resistance

Selection of the value of the field discharge resistance is, therefore, a decision that may require judicious application of several factors present on a particular systems drive, taking into account torque, excitation systems, and control components.

To pull the motor into synchronism requires that sufficient torque be developed after removal of the discharge resistor to drive the load plus accelerate the system inertia through 180 degrees.

The importance of speed for applying field cannot be overemphasized. Common sense makes it evident that it would be a low inertia indeed which could be accelerated to full speed within 180 degrees from a value of slip much in excess of 10 percent. Speed at which field is applied is considered to be more important than correct angle.

www.ElectricalPartManuals.com

Synchronous-motor controllers which can accurately apply field at optimum speed and favorable angle permit matching the motor to the load with a greater degree of precision than might otherwise be possible. The increase in load which can be pulled-in due to precision application of field will vary from one motor design to another and with system inertia.

Applying excitation at the point of zero induced current (favorable angle) takes advantage of motor capability in two ways: (1) it catches ("traps") salient pole flux at a significant magnitude (provided there is a field discharge resistor of adequate value) and

uses it for torque during a 180-degree acceleration period, and (2) it catches the rotor in correct angular position to be pulled forward into step.

In addition to permitting closer matching of motor to load, optimum application of excitation also reduces power system disturbance which occurs when the motor goes through a complete slip cycle with field energized. If the motor is large relative to the power system, surges transmitted to the system will be at a minimum if field is applied to prevent slip at pull-in.

II SYNCHRONOUS-MOTOR CONTROL

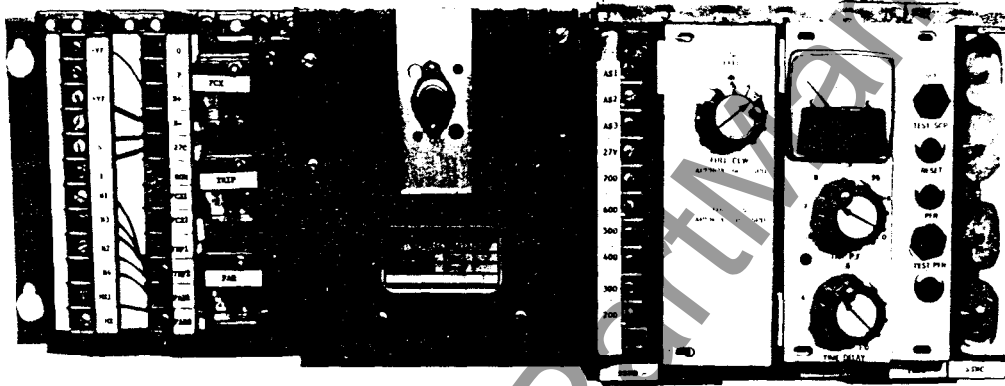

Fig. 6. IC3655A105 synchronizing and protection module

A. General Description of Controllers

The IC3655A105 — solid-state starting and protection module contains the logic circuits essential for starting, synchronizing, and protecting synchronous motors. When used with electro-mechanical devices in the motor line and field circuits (contactors and breakers), the combination makes a complete synchronous motor controller.

The synchronous-motor controller has two basic functions:

- a. Starting and synchronizing
- b. Motor protection

Fig. 7 shows the basic power and magnetic control circuits of a synchronous-motor controller. Fig. 8 is a simplified logic diagram of the synchronizing and protective functions. A detailed description of the various functions is included elsewhere in this publication. A brief description of the general functions follows.

A1.0 A-c Power Switching to the Motor

1.1 Magnetic Full-voltage Starting

Pressing the START button will cause the main line contactor to close, and full voltage will be applied to the motor terminals.

1.2 Magnetic Reduced-voltage Starting

Pressing the START button will cause the starting contactor to close, and reduced voltage will be applied to the motor terminals. After a pre-determined time interval, an adjustable-time transfer relay will operate to reconnect the motor from the starting connection to the running, or full-voltage, connection.

1.3 Magnetic Part-winding Starting

The sequence of operation of the a-c power switching for part winding is equivalent to the preceding paragraph when a portion of the motor winding is first connected to the power source. After a pre-determined time

www.ElectricalPartManuals.com

interval, a second portion of the motor winding is connected in parallel with the first portion; or, in effect, normal or full voltage is applied to all windings of the motor.

Part-winding starting may be accomplished in two steps or more, with each step following the first in a timed sequence as described above until the full winding is energized.

A2. Field Control

Induced current in the motor field, produced during starting, is passed through a discharge resistor in the starter by means of a closed contact on the field contactor. Voltage in the field winding is thus held to a safe value during the starting period. D-c voltage from an exciter is applied to the field at proper speed and favorable rotor angle by the field contactor which is closed by action of electronic circuits: the field-discharge resistor path being opened simultaneously.

Removal of field under overload is accomplished usually within the first slip cycle of pullout by electronic circuits.

A3. Protection

The standard starter includes protection against overheating of the squirrel-cage (amortisseur) winding during starting, and protection against overheating of the stator winding during running.

All control functions are discussed in greater detail in other sections of this instruction.

B. Installation and Start Up

B1. Installation

Inspect all wiring and see that the connections are clean and tight, and that there are adequate clearances for all devices.

All external wiring from the controller must be made in strict accordance with the main connection diagram supplied with the controller.

While referring to the main connection diagram supplied with the controller, inspect the wiring to determine definitely that the starting and field-discharge resistor is connected in the motor field-discharge circuit through the discharge (closed) contact of the field-applying contactor (FC).

DO NOT APPLY power to the controller or the motor until the instructions under "OPERATION" have been studied.

B2. Grounding

Equipment should be grounded to a suitable system ground. The a-c control power circuit is grounded unless Customer's specification requests an ungrounded circuit.

The S/P-M (-VF) must be grounded to prevent the possibility of high induced voltages causing damage during starting. It is recognized, however, that the motor field should not be solidly grounded continuously; therefore, a resistor (FGRS) is inserted between the motor field and ground. This resistor is 2500 ohms for fields rated 125 volts and 5000 ohms for fields rated 250 volts and limits ground-fault currents in the field to less than 0.05 amperes.

B3. Start-up Procedure

With control power applied to the controller, check out the IC3655A105 (S/P-M) module as follows:

- a. Relay TRIP should pick up and its internal indicating light should come on. If indicating lights are illuminated on either of the two other transparent-encased relays, depress the RESET button. Lights should go out on all except TRIP.
- b. TEST SCP: With motor not running, press this button and SCP light should come on after a time approximately equal to motor allowable stall time. After test is complete, depress RESET button.
- c. TEST PFR: (PF meter should indicate unity with motor not running.) Turn TRIP SET knob fully clockwise. Depress PFR TEST push button. Relay FAR will pick up followed by relay FCX three seconds later. After a time delay of 0.2 to 1.0 seconds (as set on TIME DELAY) following pickup of FCX relay, the TRIP relay will drop out and PFR indicator light should come ON. Depress RESET button and reset TRIP SET to 0.8.
- d. Start motor and closely observe movement of Power Factor Meter on the S/P-M module. If meter moves in the lagging direction, inputs are correct. If it moves in the leading direction during starting, current leads to S and T must be reversed for corrected operation of the power factor circuit.
Controller is now ready for use.

www.ElectricalPartManuals.com

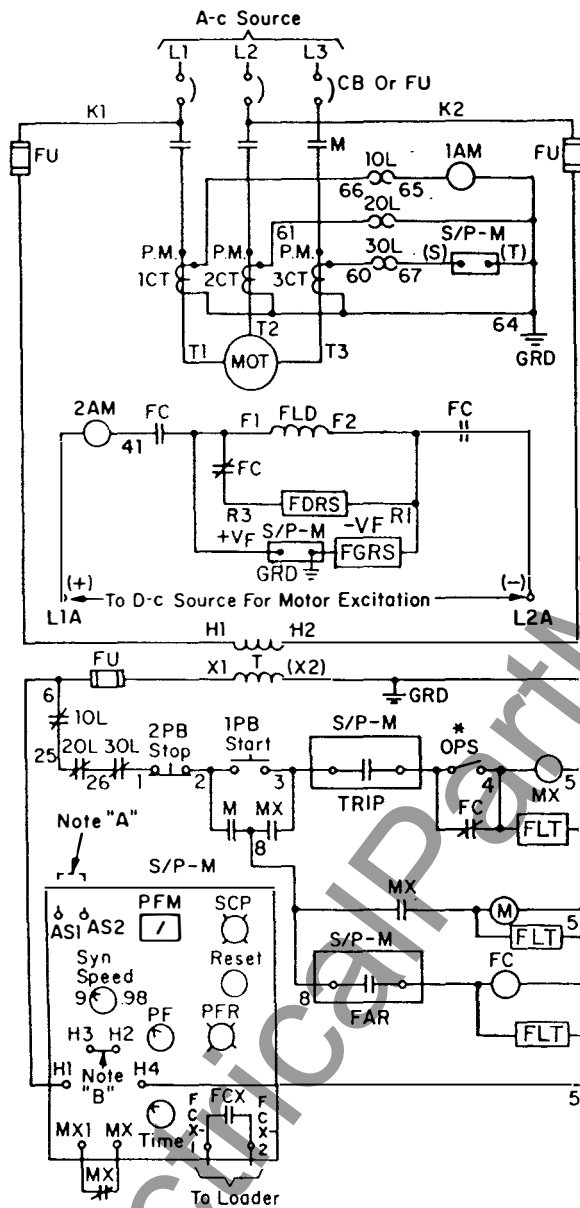

Elementary Diagram
Synchronous-motor
Controller Full-voltage
Nonreversing

Note A-
This Controller Is Shipped
With Jumper Removed.
This Permits Field Removal
From Negative Induced
Current On Pull-out, But
Shutdown Only From Logging
Power Factor.

Note B-
Jumper Shown For 230-volt
Control. For 115-volt Jumper
H1 To H3 And H2 To H4.

- Nomenclature
- 1AM A-c Ammeter
 - 2AM D-c Ammeter
 - CB Circuit Breaker
 - 1,2,3CT Current Transformer
 - FC Field Contactor
 - FDRS Field Discharge Resistor
 - FGRS Grounding Resistor
 - FLD Field
 - FLT Filter
 - FU Fuse
 - GRD Ground
 - L1,L2,L3 Incoming Terminals
 - M Main Contactor
 - MOT Motor
 - MX Auxiliary Relay To M
 - 1,2,3OL Overload Relay
 - 1,2 PB Pushbutton
 - P.M. Polarity Mark
 - * Mounted Remote
 - T1,T2,T3 Outgoing Terminals
 - T Transformer
 - S/P-M Synchronizing And Protection Module

Fig. 7. Elementary Diagram

C. Controller Operation

C1. Starting and Synchronizing (Refer to Fig. 7)

Closing the main line circuit breaker makes power available to the control circuits and to the Synchronizing and Protective Module (S/P-M). Energizing S/P-M causes TRIP relay contacts (TRP1 - TRP2) to close, and also provides power to the electronic circuits for synchronizing and protection logic functions.

Pressing the START button will pick up relay MX which in turn energizes the coil of main contactor M. When M closes applying a-c power to the motor, induced field current flows in the discharge resistor FDRS and the voltage drop across it appears at S/P-M (+V_F and -V_F). Frequency of this induced field voltage decreases as the motor speed increases, and the speed sensing circuits of S/P-M cause relay FAR (FAR1 and FAR2) to close as the motor reaches approximately 95-percent speed (or whatever speed is set

www.ElectricalPartManuals.com

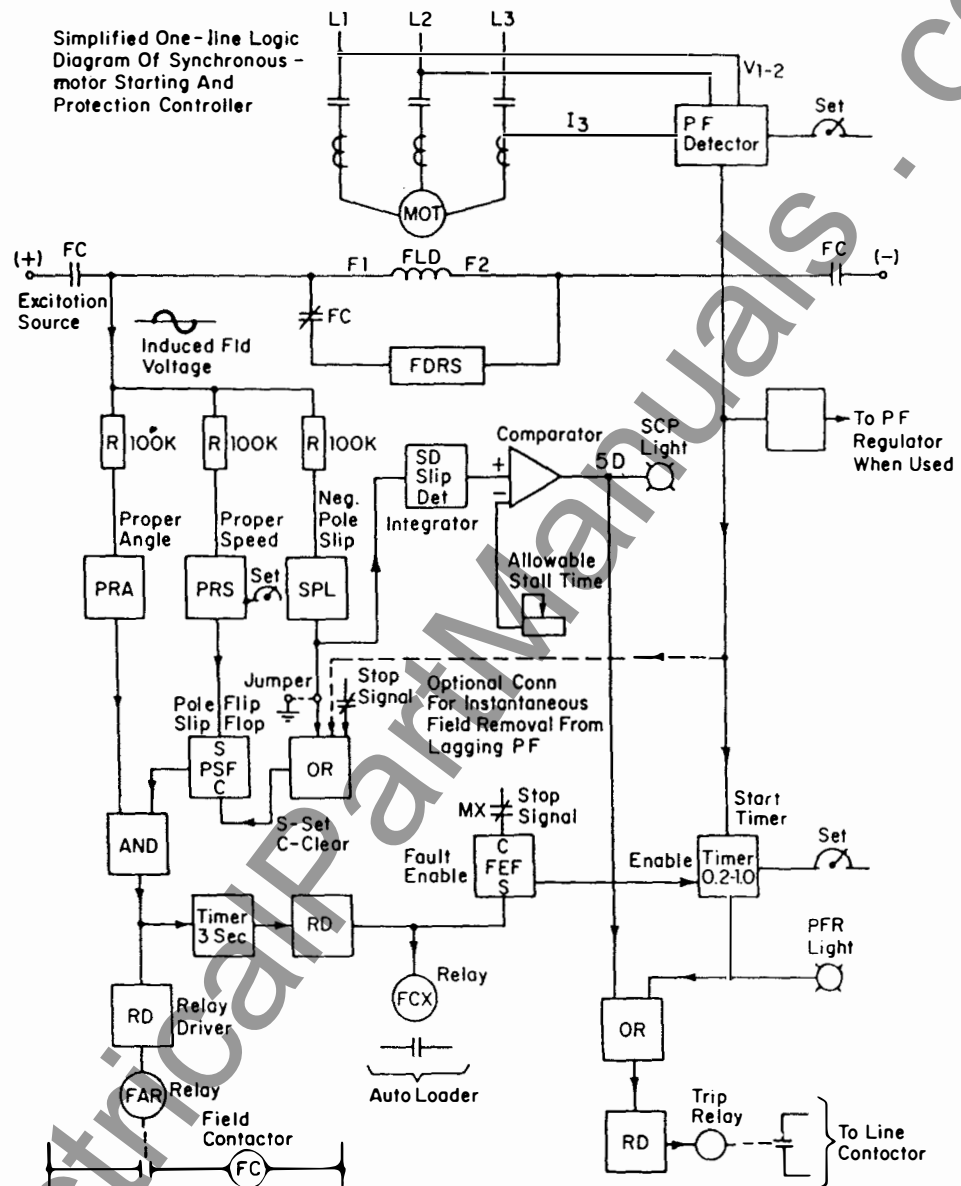

Fig. 8. Schematic diagram

on SYN SPEED dial). When FAR closes, the field contactor FC picks up and applies excitation to the motor from the exciter.

Relay FCX picks up and closes its contacts approximately three seconds after the motor synchronizes, allowing automatic loading circuits to be activated.

C2. Protection

2.1 Pull Out

If excessive mechanical load is applied to the motor shaft during normal running of the motor in synchronism, the resulting lagging power factor will be detected

by the S/P-M. Its logic circuits are arranged normally (as shipped from the factory) as follows:

- Relay FAR drops out instantly on first slip cycle producing negative pulse from the field. FC then removes field excitation to the motor.
- Relay FCX drops out at the same time as FAR. Load is removed if an automatic loader is connected.
- The motor will run with field removed for the time set on the P. F. TIME dial (maximum of 1.0 second), and if resynchronization does not occur within this time, the TRIP relay will operate and the motor will stop.

www.ElectricalPartManuals.com

Alternate connections may be made to prevent field removal on first slip cycle by adding jumper from AS1 to AS2 on terminal strip.

If this change is made, field is not removed immediately on pull-out, but motor shuts down if lagging power factor persists through the time setting P. F. TIME dial.

There are some motors which, due to design and other conditions, do not produce a negative half cycle of induced current during pull-out from overload. On such motors, the control may be set to remove field on first slip cycle instantly from lagging power factor by connecting

jumper from terminal LPF to LPF1 on terminal board of card IC3650SSND1 and removing the jumper from LPF1 to COM.

2.2 Thermal Protection

The motor stator winding is protected against running overloads by thermal-overload relay. The tripping of these relays corresponds to the stator-winding heating curve.

To provide adequate protection to the squirrel-cage winding (amortisseur) during starting, the logic circuits include a function for integrating the slip frequency voltage during stall and during acceleration and trip the motor off the line if limits are exceeded.

III. DETAILED DESCRIPTION OF IC3655A105 MODULE

A. Starting and Synchronizing

Control functions for starting a synchronous motor include:

1. Applying power to the stator; at full voltage or at reduced voltage.
2. Connecting a resistor in series with the field.
3. Sensing rotor speed.
4. Sensing rotor angle.
5. Applying excitation at optimum speed and angle.
6. Reluctance torque synchronizing.

Applying power to a motor by magnetic contactor or circuit breaker is strictly a conventional operation. Essentially the same for a synchronous motor, squirrel-cage motor, transformer, or any other load. Synchronous motors require nothing exceptional for this function.

Connecting a resistor in series with the motor field during starting is accomplished by magnetic contactor. Optimum application of excitation (that is, closing the field contactor) requires accurate sensing of motor speed and rotor angle. Optimum speed for pull-in will vary somewhat from one motor design to the next, and with the value of the field discharge resistor. Adjustment of the control to apply field at various values of motor speed is important. Correct rotor angle for field application does not vary, however, and is always the point where induced field current passes through zero going from negative to positive; the point of maximum flux in the rotor. Maximum utilization

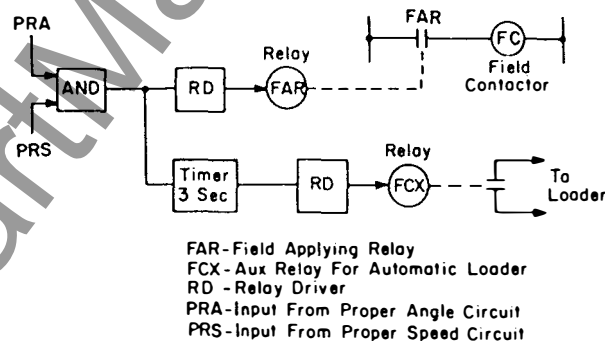

OPERATION

When motor reaches synchronizing speed, as set on dial (90-98 percent speed), the PRS timer sets flip-flop PSF and applies an input to AND. The AND then waits for its second input from PRA, proper rotor angle, which energizes relay driver RD to cause FAR to close. Relay FAR energizes field contactor.

The AND activates timer which, after a 3-second delay, causes relay FCX to close.

Fig. 9. Motor-field application logic

of motor pull-in capability will depend upon the degree to which the controller can accurately sense speed and rotor angle.

Rotor frequency is the most positive electrical parameter available for indicating speed, and can be sensed by detecting frequency of the voltage across FDRS. Voltage across FDRS is not actually "induced field voltage", but is the voltage across the discharge resistor and is essentially in time phase relation to the current through the resistor. That is, it goes through zero the same time the voltage goes through zero.

www.ElectricalPartManuals.com

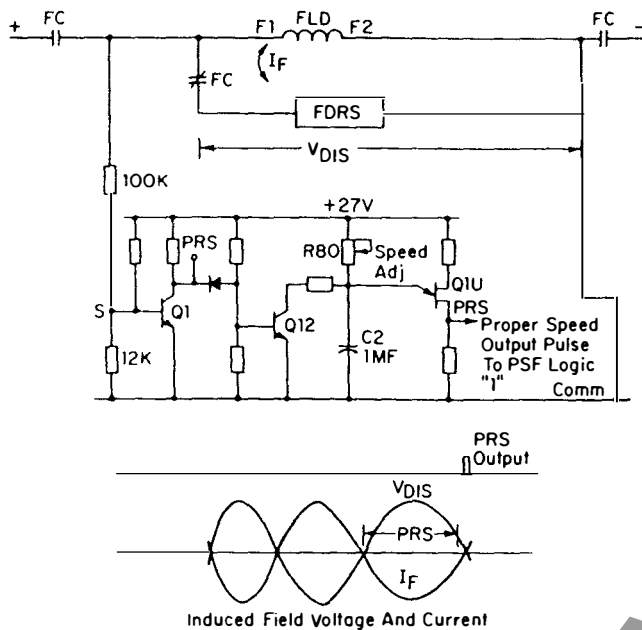

OPERATION

During positive half-cycles of induced field voltage, Q1 is turned ON, turning Q12 OFF, and allowing C2 to charge through R80. When V_{Dis} goes negative Q1 is OFF, Q12 is ON, and C2 is discharged by Q12. When positive half-cycles become long enough (indicating high speed), voltage on C2 will reach standoff ratio of UJ-Q1U and it will deliver a pulse to proper speed logic circuit. Adjustment of R80 determines charging time of C2, and consequently synchronizing speed.

Logic "1", output at PRS appears only at end of positive half-cycle of V_{Dis} exceeding time setting of R80.

Fig. 10. Slip speed sensing circuit

Fig. 10 and Fig. 11 are drawn to illustrate schematically the electronic circuits which determine motor speed and rotor angle for synchronizing. The circuits are illustrated separately for simplification and clarity, where in the module, they are integrated into one and are constructed and assembled with other functions to make a complete modular unit. (See diagrams - pages 22-27.)

Outputs from proper speed circuit and from proper angle are fed into an AND junction from which there is output only when both inputs are equal. That is, when the motor reaches proper speed and proper angle for synchronizing. A signal is delivered to the field applying relay FAR to cause it to close its contacts. FAR picks up field contactor FC to apply excitation to the motor rotor and to open the field discharge resistor loop.

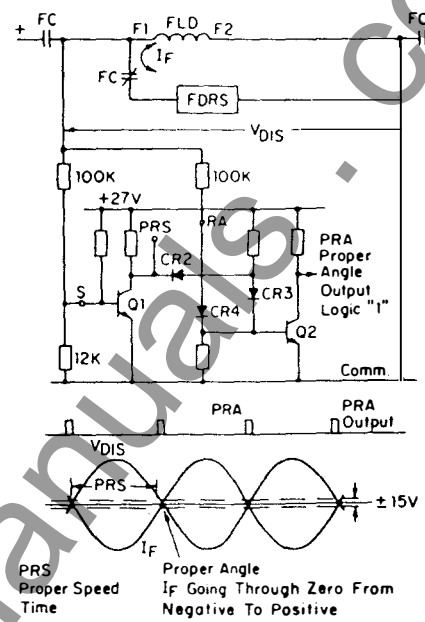

OPERATION

Q1 is also used in proper speed circuit. Logic "1", positive output at PRA, occurs only when Q2 is OFF. Q2 is turned ON, however, from positive inputs +27V thru CR3 or +RA CR4. During positive, half-cycles of V_{Dis} , RA is positive and Q2 is ON. During negative half-cycles of V_{Dis} , +27V turns Q2 ON since Q1 is OFF. As current-zero is approached from negative I_F (positive V_{Dis}), Q2 will go OFF at +15V and remain OFF to -15V of V_{Dis} until +27V turns it ON through CR3. Likewise Q2 will go OFF as current-zero is approached from positive direction as V_{Dis} reaches -15V. Logic "1" therefore appears at PRA 15 volts either side of current-zero.

Fig. 11. Proper rotor angle circuit

Speed at which the motor is to synchronize (PRS) can be adjusted over the range of 90 percent to 98 percent by calibrated knob (R80). The proper angle circuits applied through solid state logic techniques to operate a field contactor satisfy the criterion for optimum pull-in requirements of the motor; "correct" speed and induced-current zero going positive.

B. Reluctance Torque Synchronizing

A synchronous motor lightly loaded and connected to low inertia may pull-in to synchronize before the rotor poles can be externally magnetized; commonly known as reluctance torque synchronizing. This magnetization can result in sufficient torque to hold the salient poles in direct alignment with corresponding stator poles and ru

www.ElectricalPartManuals.com

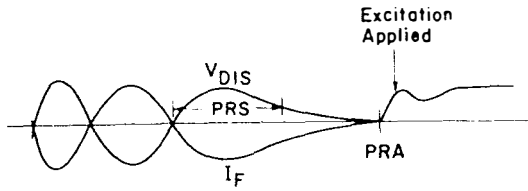

Fig. 12a.

OPERATION

MOTOR SYNCHRONIZES ON RELUCTANCE TORQUE-ROTOR CORRECTLY ORIENTED

PRS signal sets flip-flop (PSF) for positive input to AND junction when speed timer times out. Proper angle is then indicated by zero I_F delivering second input to AND junction which causes pickup of relay FAR.

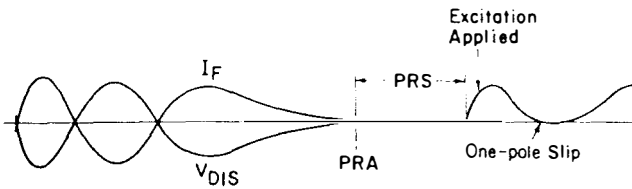

Fig. 12b.

OPERATION

MOTOR SYNCHRONIZES ON RELUCTANCE TORQUE-ROTOR DISORIENTED 180 DEGREES

PRA signal comes on at current-zero causing input to AND junction. PRS timer runs when there is no input from induced voltage. Therefore second input to AND junction occurs at end of PRS time and causes pickup of relay FAR.

the motor at synchronous speed. When load is applied, however, the rotor will begin to slip since the torque developed is only a fraction of rated torque under separate excitation. Furthermore, the rotor is polarized by the stator flux only under this condition and can therefore be polarized in any direct axis alignment; each 180 degrees. External excitation requires polarization pole-to-pole in only one orientation of the direct axis. Should the rotor pull-in to synchronism 180 degrees away from the normal running alignment, external excitation must build up flux in the rotor in opposition to the stator flux, nullifying the reluctance torque, and momentarily driving the net torque to zero. As the external excitation builds up, correct alignment of rotor to stator will occur by slipping one pole and the motor will then run in normal synchronism at rated torque.

The field application control must respond in such way as to proceed with proper application of excitation in the event the motor does synchronize on reluctance torque. Fig. 12a and 12b show how the IC3655A105 automatically responds to reluctance torque synchronizing.

C. Motor Protection

Any condition which raises the temperature of various elements of a motor above designer's limits will effect its life. Overheating is therefore an enemy that must be dealt with by the protective functions of synchronous motor controllers. "Heating above limits" is a phrase that is often misinterpreted and misapplied, however, since a motor is thermally much more complex than such things as fuses, for instance, which are designed to melt instantly when some value of I^2t is reached. A motor contains several metals (copper, brass, bronze, solder, iron) and a variety of insulating materials, all of which are effected differently by temperature. Motor designers usually establish limits in parameters measurable at the various electrical terminals, such as line current versus time, induced field current versus time; or, some form of inherent detectors are installed which measure temperature directly. These limits are then used by the control designer as the basis for action to prevent reduction in motor life expectancy. Precision in protection is a somewhat nebulous concept, however, and should not be confused with precision and reliability in protective devices themselves. Devices and circuits for motor protection must be reasonably precise and sufficiently predictable in their characteristics to be sure they follow the motor designer's recommendations, but it should be kept in mind that the motor designer is merely trying to prevent rapid reduction in motor life, and there are wide limits in time and temperature within which life is effected.

The amortisseur, or cage winding of a synchronous motor, is probably the element most susceptible to thermal damage. Its function is essentially operative only during starting, and there are limitations on space available for its construction onto the rotor. Hence, it is usually made of lighter material than the cage winding of an induction motor. The cage is also vulnerable to overheating should the motor be allowed to run out of synchronism with no excitation. In this case, it runs as an induction motor at some value of slip which will produce cage current that develops running torque. The cage of a synchronous motor is not designed for continuous operation, however. So, an important protective function of the controller is to prevent overheating of the cage winding both during starting and running out of synchronism.

www.ElectricalPartManuals.com

Table 1. Synchronous-motor protection summary

Type of Protection	Nomenclature	Conditions of Possible Damage											
		Overload			Starting		Winding Insulation			Loss of Excitation			
		Running	Pullout	Sudden Stall	Stall	Prolonged Acceleration	Ground Fault	Turn-to-Turn	Phase-to-Phase	No Field Volts	No Field Current		
Stator Thermal-Overcurrent Relay	OL	X											
Power Factor	S/P-M		X	X								X	X
Inverse-Time-Induced-Field Current	S/P-M				X	X						X	X
Field-Voltage-Check Relay	VCR											O	
Field-Current-Loss Relay	FLR												O
Ground Fault Relay	GF							O					
Instantaneous Over-current Relay	OC			O									
Differential Relay	DR							O	O				
Current-Balance Relay	CBR	△						O					
Incomplete Sequence Relay	ISR									O			

X - Included with standard controller
 O - Not included with standard controller; must be added to order
 △ - Current unbalance causes overheating

There are four situations of the motor that must be monitored so as to prevent damage:

- 1) Stall or prolonged acceleration.
- 2) Overload:
 Continuous running overload in synchronism
 Pullout
- 3) Loss of excitation:
 Running as an induction motor
- 4) Winding insulation failure:
 Phase fault
 Ground fault

C1.0 Starting Protection

Fortunately, monitoring the starting condition of a synchronous motor can be accomplished by looking at the frequency of induced field current, just as is done to accomplish synchronizing. As pointed out above, the cage winding is the most vulnerable element during starting and as a consequence, motor designers always place a limit on the time a particular motor can be allowed to remain stalled ("allowable stall time"). An acceleration schedule can then be established for the motor in terms of running time at any speed less than synchronous as a percent of allowable stall time. There are two factors which reduce heating as the motor accelerates: air circulation from the fan effect the

* "Allowable stall time" is important for induction motors also, but the time is usually shorter for synchronous motors and varies from one design to another with greater spread.

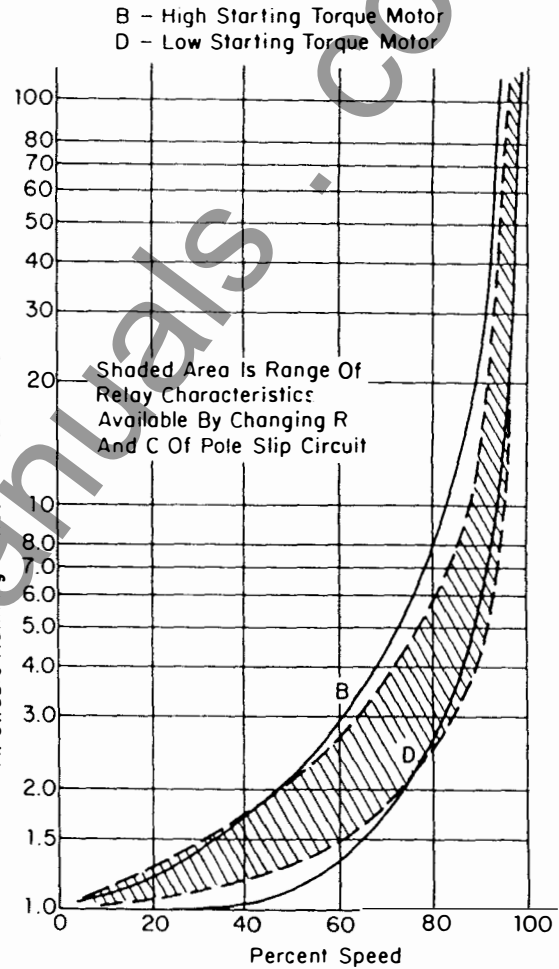
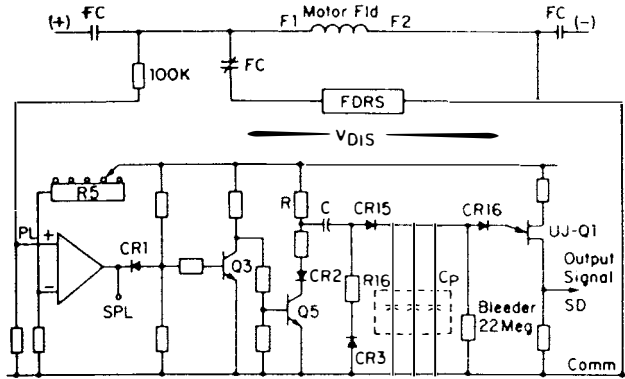

Fig. 13. Typical synchronous-motor squirrel-cage heating characteristics

rotor, and reduced frequency of current in the rotor. Frequency can be measured directly as an indication of speed, and the designer's curves for speed versus time can be used for protection by circuitry that integrates the time-speed function. Fig. 13 shows typical cage heating characteristic during acceleration.

The electronic circuit for integrating the time-speed function is shown in Fig. 14. After the motor is initially started, charge remains on C_p until it bleeds off through the 22 MEG resistor, which provides circuit memory to prevent successive restarts that may damage the motor. The bleeding time of C_p through 22 MEG resistor is about 1 minute. If the motor is restarted in less time, it could cause the circuit to trip. The capacitors discharge through emitter of UJ Q1 upon reaching the trip point. Restarting is then up to the discretion of electrical maintenance personnel who would be called upon to operate the RESET function.

www.ElectricalPartManuals.com



OPERATION

Positive half-cycles of V_{Dis} shutoff Q5 and allow C and C_p to charge through R. Negative half-cycles of V_{Dis} cause Q5 to conduct and to discharge C through the loop formed by CR2, Q5, CR3, and R16. C_p does not discharge, however, because it is blocked by CR15. Capacitor C is small in comparison with C_p so each charging cycle only partially charges C_p ; the rate of charge each half-cycle depends upon ratio of C/C_p and charge existing on C_p , and will be an exponential function. When total voltage on C_p reaches standoff ratio of UJ-Q1, a pulse of logic "1" will appear at SD to be fed into logic for tripping as shown in Fig. 17.

Fig. 14. Pole slip detector circuit

The component values of C, C_p , and R are selected to match motor heating curves shown in Fig. 13 and the motor allowable stall time. Taps on R5 are set so there is no output from the comparator unless induced voltage is higher than excitation.

C2.0 Overload Protection

Continuous running overload protection of a synchronous motor is normally afforded by monitoring stator current with inverse-time thermal relays. This function for a synchronous motor is essentially no different than for other a-c motor types and can be expanded to include winding temperature detectors or other types of inverse-time devices. The synchronous motor can be overloaded to the point where it will pull out of synchronism, however, and this marks the distinct difference in its protection requirements.

Synchronous motors are designed to run at constant speed and drive shaft load by torque derived from the polarized iron cores on their rotors which magnetically link corresponding stator poles. Whenever the rotor turns at a speed less than the stator flux, the

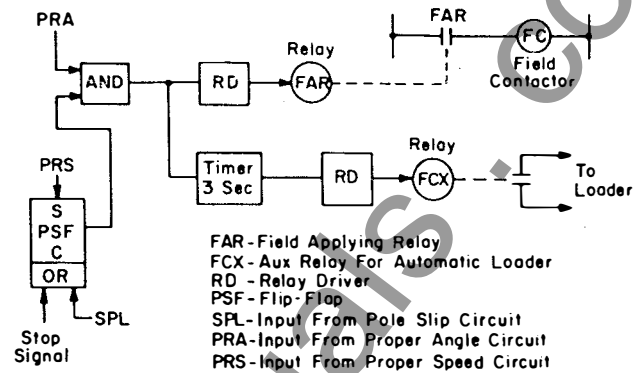

OPERATION

PSF is set by PRS; cleared by either the stop circuit or SPL.

One pole slip as indicated by negative induced field amperes from SPL will remove drive on relays FAR and FCX. FAR removes field excitation from motor and FCX removes load.

Fig. 15. Motor-field application logic

motor is said to "slip". Slip can begin with the field poles magnetized while running in synchronism from four major causes:

- 1) A gradual increase in load beyond the pull out capabilities of the motor.
- 2) A slow decrease in field current.
- 3) A sudden large impact load.
- 4) A system fault or voltage dip lasting long enough to cause pull out.

Loss of synchronism with field poles magnetized will create wide pulsations in torque at the motor shaft each time a stator pole passes a rotor pole. Corresponding pulsations occur in line current. Both types of pulsations can be damaging. Torque pulsations can break a shaft, coupling, or other mechanical element, and current pulsations can interfere with efficient power system operation. Slipping with rotor poles magnetized (field applied) is therefore always unacceptable for a synchronous motor and some means must be provided to prevent it.

One of the most reliable indicators of synchronous and asynchronous (out-of-step) operation is power factor in the line to the motor. That is, the phase angle between voltage

www.ElectricalPartManuals.com

and current. Synchronous motors seldom, if ever, operate continuously at lagging power factor. They run at either unity or some value of leading angle between current and voltage. Lagging power factor always appears when the motor load angle increases beyond rated, becoming fully lagging (90°) as the motor just pulls out-of-step. Lagging power factor may therefore be utilized to initiate action to prevent slipping.

Torque and power pulsations during slip can be reduced by removing field current to the rotor poles. The motor would then run essentially as an induction motor by its squirrel-cage winding. Slip with field current removed is tolerable to the load and power system but intolerable for any length of time to the motor squirrel cage winding itself, since it is designed with limited thermal capability and for short-time operation. Motor Power Factor during induction motor operation (that is with field removed) is always lagging. However, the degree to which the current lags the voltage is less than at pull-out when field poles are excited. Lagging power factor therefore can again be utilized as an indicator of "slip" during induction motor operation.

For synchronous motors, therefore, some means must be provided to guard against two kinds of slip; slip with field applied, which causes 90 degree lagging (0%) power factor, and slip when running without field applied which causes lagging power factor in the order of 60 to 80 percent.

Although lagging power factor always occurs during slip, there are other transient situations of the power system and motor which can cause a momentarily lagging power factor. These situations may be of such short duration that the motor will continue to run in synchronism. Very rapid response of a so-called power factor relay in these situations would cause unnecessary shut-down. Inherent time delay (adjustable) would permit delay in operation unless the power factor remained lagging for a predetermined time, indicating persistent pull-out.

Motor pull-out protection from overload is efficiently provided by a circuit which monitors power factor and has a built-in time delay to prevent inadvertent tripping on transients. The circuit is shown in Fig. 17.

An analog voltage signal appears at point W whose magnitude is proportional to the phase angle between line current and line voltage. (See Fig. 16.) At unity power factor, the angle is 90 degrees if voltage input at points Q and P is from L1 to L2, and the current input at F and G is from L3. Phase rotation being L1-L2-L3.

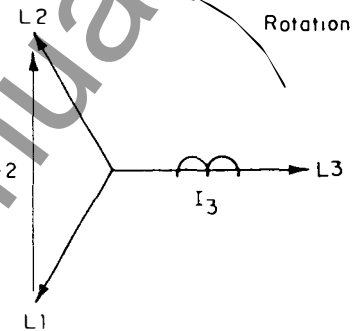

Fig. 16. Voltage current phasors

The EXCLUSIVE-OR power-factor circuit is arranged so the output signal at W is 5 volts at unity power factor, zero at 90 degrees lag (0 P. F.), and 10 volts (10 MA thru PFM) at 90 degrees lead (1.0 P. F.). Output signal varies between 0 and 10 volts in relation to the cosine of the angle between voltage and current inputs.

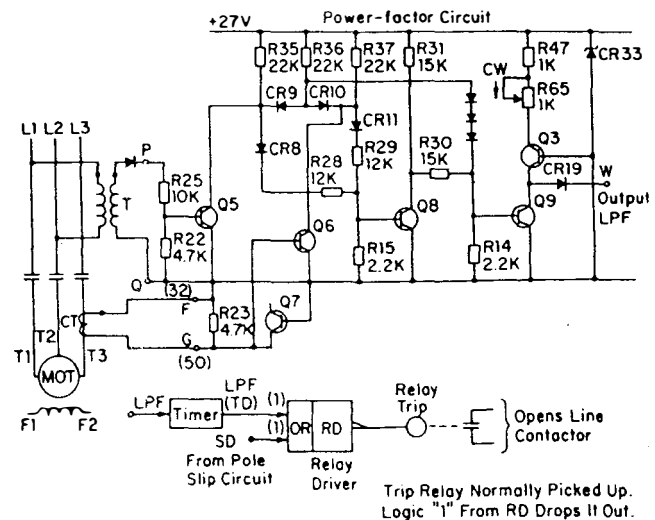

Fig. 17. Motor pull-out protection from overload circuit

www.ElectricalPartManuals.com

Brief Description of Circuit Operation:

Positive half waves of voltage input L1-L2 turn Q5 ON, and positive half waves of current input L3 turn Q6 ON. Whenever Q5 and Q6 are both in the same state, either ON or OFF, Q9 is turned ON. The circuit therefore has four extremes:

1. Q5 and Q6 both ON: voltage at R36 is low, and base drive of Q9 is through R31 and R30; Q8 is OFF since voltage is low at its base. Q9 is ON and shunts current to COM away from W.
2. Q5 and Q6 both OFF: voltage at R36 is high which drives Q9. Q8 is ON but cannot lower Q9 base drive due to 15K R30. Q9 being ON shunts current to COM away from W.
3. Q5 ON and Q6 OFF: voltage low at R36 and R35 but high at R37 which turns Q8 ON. Q8 decreases drive on Q9 and turns it OFF; current then flows through W.
4. Q5 OFF and Q6 ON: voltage high at R35 and low at R36; R36 cannot drive Q9, and Q8 turns ON to prevent drive through R31 and R30. Q9 OFF, current flows through W.

In summary, lagging power factor results in LOW output signal at point W due to shunting effect of Q9. This signal is utilized in a logic function to cause drop out of the trip relay after a time delay.

Power-factor logic shown in Fig. 18 is therefore applicable to the total device. Low signal resulting from lagging power factor will drop out trip relay. High signal resulting from unity or leading power factor will hold the relay in.

Motor pull out will also produce negative induced field current in some motor designs. Negative induced field current is equivalent to an increase in induced field voltage exceeding the applied voltage. Investigation of motor designs and simulated conditions for pull out applied to these designs, however, demonstrated that high field voltage is not a completely reliable indication of pull out because a sizeable variety of motor designs and conditions of pull out do not exhibit negative pulses of current. The conclusion could be drawn that negative induced field current should not be considered as an indicator of pull out. If detection of pull out under impact load is of paramount importance then the conclusion is valid, and it would be prudent to rely upon lagging power factor to detect pull out. There are some drives how-

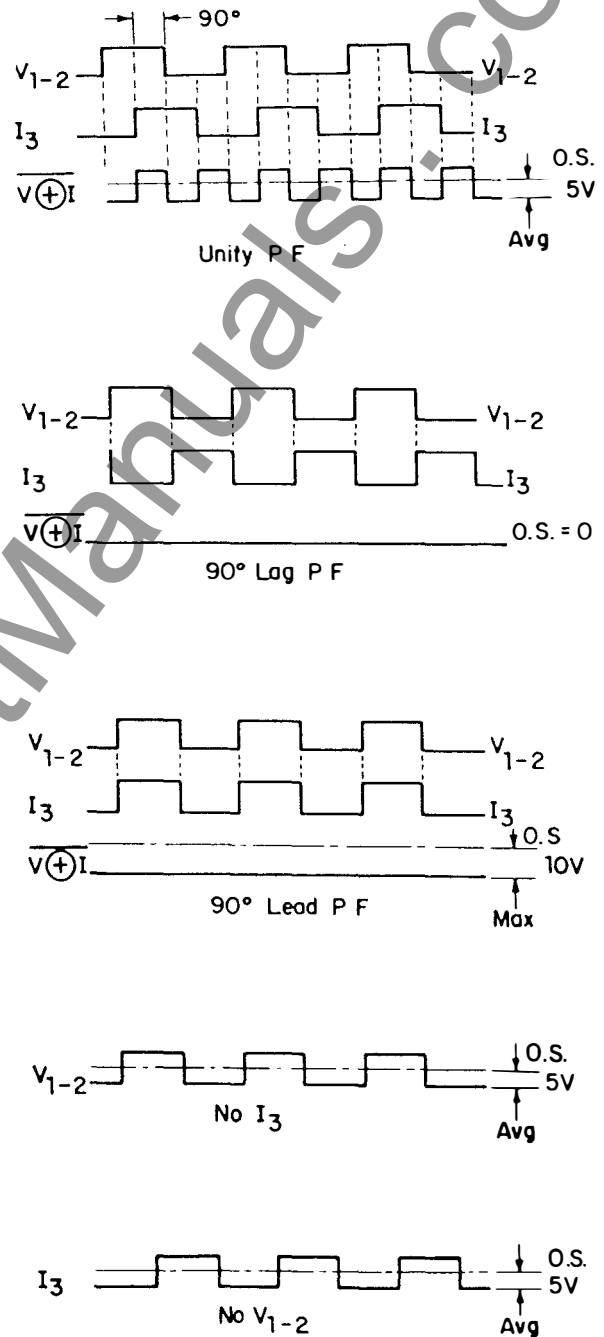
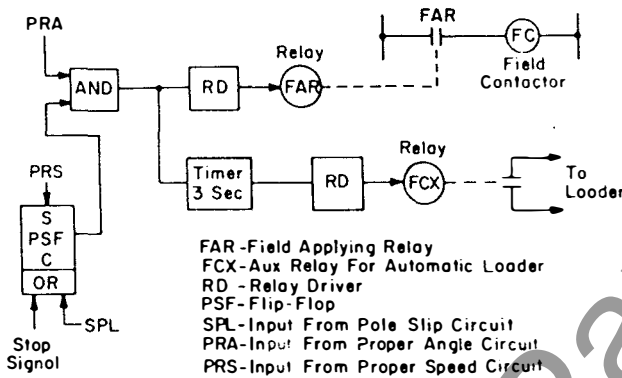

Fig. 18. Power-factor logic

ever which are not likely to experience impact loads but which would be inadvertently shut down by transient conditions causing lagging power factor. For these drives, depending on motor design, negative induced field current would be a preferable indicator of pull out to remove field excitation only, and then rely upon lagging power factor persisting for a definite time before actuating shutdown.

www.ElectricalPartManuals.com

Pole Slip Detector input PL of Fig. 14 is connected to continuously monitor the motor field even after synchronization. If the motor should go through a complete slip cycle with field excited, a positive voltage pulse will appear at SPL (provided the conditions of pull out and motor design discussed above are conducive). This positive pulse is fed into additional logic coupled to the Motor Synchronizing Logic (Fig. 19) to de-energize relay FAR and remove field excitation. If the motor continues to run out of synchronism beyond the time setting of the power-factor detector circuit, then shutdown is initiated through the Trip Relay (Fig. 17).



OPERATION

PSF is set by PRS; cleared by either the stop circuit or SPL.

One pole slip as indicated by negative induced field amperes from SPL will remove drive on relays FAR and FCX. FAR removes field excitation from motor and FCX removes load.

Fig. 19. Field removal logic

C2.1 Effect of Voltage Dips on Motor Power Factor

Solid-state excitation systems have an effect on the way motor power factor responds to line voltage dips. The effect may be to cause a power-factor relay to operate inadvertently. That is, to trip on lagging power factor caused by a transient condition which is not an actual pull out condition.

A solid-state exciter differs from a rotating exciter in the way it responds to voltage dips. The rotating inertia of an MG set may maintain excitation voltage relatively constant for several seconds.

but a solid-state exciter has practically no built-in delay in the way it responds to line voltage. Any delay in change of motor rotor flux following an excitation voltage change is therefore determined by the time constant of the rotor field poles themselves. This is usually 0.5 to 1.0 second.

The sequence of events transpiring during a voltage dip with a solid-state exciter is depicted in Fig. 20. Assuming a line voltage decrease of 15 percent with the motor initially at unity power factor, the power factor will swing leading momentarily because the generated EMF does not change until the rotor flux decreases (determined

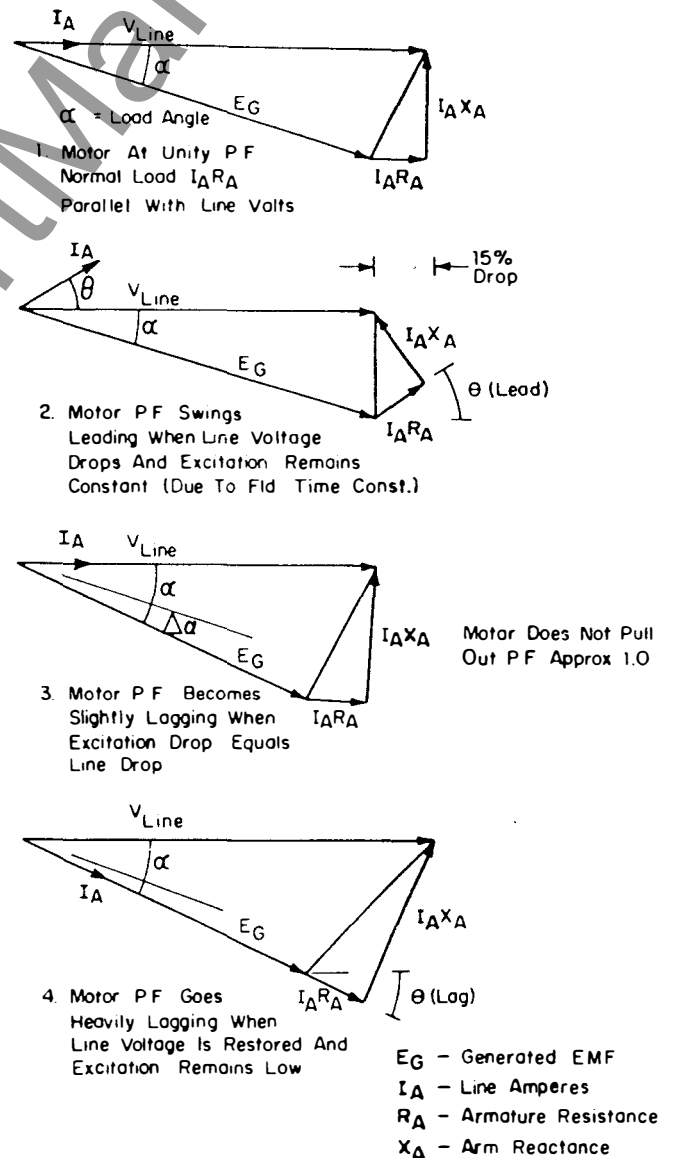

Fig. 20. Effect of line voltage dip on motor power factor (assuming no line voltage phase shift)

www.ElectricalPartManuals.com

by field time constant) and the motor will tend to maintain constant horsepower by slightly increasing line current. As the field flux decreases, generated EMF also decreases, and the power factor will move back towards unity, although there may be a load angle increase to permit motor torque to be restored to that required to drive the load. During both these sequences the motor power factor has not become significantly lagging, so the power factor relay does not operate.

Finally, when line voltage comes back to normal, the power factor will momentarily swing over to lagging and an instantaneous relay will trip, because the rotor flux does not respond as rapidly to change as does the stator, and generated EMF is low relative to line volts long enough to operate the relay.

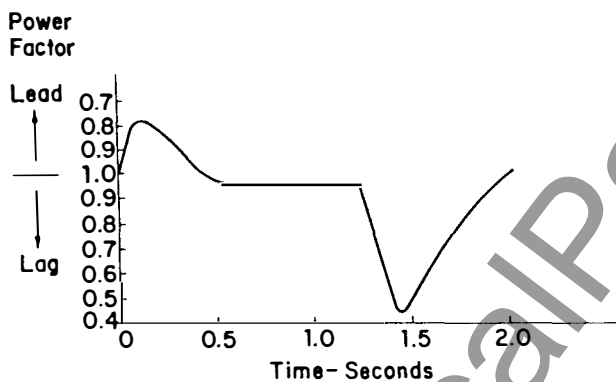

Fig. 21. Motor power-factor response to a two-second line-voltage dip: solid-state exciter

A power-factor device with a 1.0-second built-in time delay will remain unaffected by these changes.

C3.0 Loss of Excitation

Running out of synchronism without excitation (running as an induction motor) will cause overheating of the cage winding. This condition can be detected by the power factor circuit of Fig. 17 if it is set above the expected induction motor power factor, which would be approximately 0.8 lag. Shutdown will follow loss of excitation within the time setting of the power-factor-trip circuit. The pole slip detector will also function to shut the motor down after the motor has slipped long enough to build up sufficient charge on the capacitor C_p based on the curve of Fig. 13.

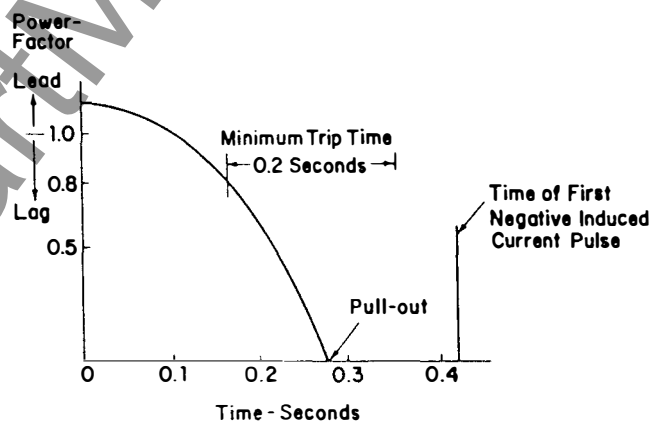

Fig. 22. Change in power factor with a 225-percent impact load application (relay operates before a complete slip cycle transpires to produce torque oscillation)

www.ElectricalPartManuals.com