



**UNINTERRUPTIBLE POWER SUPPLY
7011A SERIES UPS**

SINGLE PHASE PRODUCT

6kVA
8kVA
10kVA
12kVA

OWNERS / TECHNICAL MANUAL



Preface

www.ElectricalPartManuals.com

TABLE OF CONTENTS

LIST OF TABLES	iii
LIST OF FIGURES	iv
HOW TO USE THIS MANUAL	v
SAFETY PRECAUTIONS HOW TO USE THIS MANUAL	vi
1.0 INTRODUCTION	1-1
1.1 GENERAL.....	1-3
1.2 DEFINITIONS	1-4
1.3 OVERVIEW	1-5
1.4 SPECIFICATIONS	1-12
2.0 OPERATOR CONTROLS AND INDICATORS	2-1
2.1 STATUS INDICATORS	2-2
2.2 LCD DISPLAY	2-4
2.3 RS232C CONNECTOR (External communication connector).....	2-7
2.4 D-SUB 25 PIN CONNECTOR	2-8
2.5 EXTERNAL SIGNAL TERMINAL BLOCK	2-9
3.0 INSTALLATION AND OPERATION	3-1
3.1 TRANSPORTATION AND INSTALLATION	3-1
3.2 INSTALLATION PROCEDURE	3-1
3.3 PROCEDURE FOR CABLE CONNECTION.....	3-2
3.4 INSTALLATION PROCEDURE FOR BATTERY	3-9
3.5 OPERATING PROCEDURES	3-12
3.6 MAINTENANCE BYPASS SET-UP PROCEDURES	3-14
3.7 EXTERNAL BATTERY SET-UP PROCEDURES	3-15
4.0 RESPONSE TO UPS FAILURE	4-1
5.0 PARTS REPLACEMENT	5-1
6.0 FAULT CODES	6-1
7.0 WARRANTY & OUT OF WARRANTY SERVICE	7-1

List of Tables

Table 1.1	Power Specifications.....	1-12
Table 1.2	UPS Module Information.....	1-12
Table 1.3	Rating of Conductor and Fuses.....	1-12
Table 1.4	Detail of Specifications.....	1-13
Table 2.1	D-Sub 25 Pin connector.....	2-9
Table 3.1	List of UPS Weights (lb.).....	3-1
Table 3.2	Recommended Cable Size and Torque Requirements.....	3-3
Table 3.3	Crimp Type Compression Lug.....	3-3
Table 3.4	Type and Number of Battery.....	3-9
Table 6.1	Failure Code List.....	6-2

List of Figures

Figure 1.1	Single Line Diagram-Normal Operation	1-5
Figure 1.2	Single Line Diagram-Bypass Operation.....	1-6
Figure 1.3	Single Line Diagram-Battery Operation	1-7
Figure 1.4	Single Line Diagram - UPS on Maintenance Bypass Operation..	1-7
Figure 1.5	UPS Parts Location (6kVA).....	1-8
Figure 1.6	UPS Parts Location (8,10,12kVA).....	1-9
Figure 1.7	UPS Parts Location (Rear view)	1-10
Figure 1.8	External I/F PCB RYER-A	1-10
Figure 2.1	Operation / Display Panel	2-1
Figure 2.2	LCD Display During Normal Operation	2-2
Figure 2.3	Tree Diagram of LCD display (Top Page)	2-4
Figure 2.4	Tree Diagram of LCD display (Normal Mode)	2-5
Figure 2.5	Tree Diagram of LCD display (User Setup Mode)	2-6
Figure 2.6	Tree Diagram of LCD display (Start Mode)	2-6
Figure 2.7	Tree Diagram of LCD display (Stop Mode)	2-6
Figure 2.8	Tree Diagram of LCD display (Stop Mode)	2-7
Figure 2.9	RS-232C Connectors	2-8
Figure 2.10	D-sub 25 Pin Connector	2-9
Figure 2.11	External Signal Terminal Block (NEC Class2).....	2-10
Figure 2.12	Control Wiring for External Contacts	2-11
Figure 2.13	Remote "Startup" Contact Connections.....	2-12
Figure 3.1	Handling	3-1
Figure 3.2	Clearance for Ventilation and Maintenance	3-2
Figure 3.3	UPS Terminal Designation.....	3-4
Figure 3.4	Terminal Block.....	3-5
Figure 3.5	Input / Output Power Terminals (6kVA) (Rear View).....	3-5
Figure 3.6	Input / Output Power Terminals (8,10,12kVA) (Rear View).....	3-6
Figure 3.7	Field Wire Connection (208V-120 V WYE, 2 Phase 3 Wire).....	3-7
Figure 3.8	Field Wire Connection (240V-120 V, 1 Phase 3 Wire)	3-9
Figure 3.9	Battery Connection when shipped	3-12

HOW TO USE THIS MANUAL

This manual is designed for ease of use, giving the user easy and quick reference to information. This manual uses notice icons to draw attention to the user important information regarding the safe operation and installation of the UPS. The notice icons used in this manual are explained below, and should be taken into account and adhered to whenever they appear in the text of this manual.



WARNING: A warning notice icon conveys information provided to protect the user and service personnel against hazards and/or possible equipment damage.



CAUTION: A caution notice icon conveys information provided to protect the user and service personnel against possible equipment damage.



NOTE: A Note notice icon indicates when the user should make a reference of information regarding the UPS operation, load status and display status.

Such information is essential if Mitsubishi field service group assistance and correspondence is required.

Safety Recommendations: If any problems are encountered while following this manual, Mitsubishi field service group assistance and correspondence is recommended.

SAFETY PRECAUTIONS

The safety precautions are categorized as **DANGER** and **CAUTION** in this instruction manual.

DANGER: A dangerous situation may occur if improperly handled, leading to severe or fatal injuries.

CAUTION: A dangerous situation may occur if improperly handled, leading to minor serious injuries.

Note that some items described as **CAUTION** may lead to severe results depending on the situation. Nonetheless, important information outlined in this section must be observed at all times.

DANGER

- **Do not dispose of the batteries in a fire as they may explode.**
- **Do not open or break the batteries. Released electrolyte is toxic and harmful to the eyes and skin.**
- **A battery can present a risk of electrical shock and high short circuit current. Observe the following minimum Safety Precautions when working on the batteries.**
 - 1) Verify that the UPS is off and that the input power plug or wires are disconnected.
 - 2) Remove watches, rings or other metal objects.
 - 3) Use tools with insulated handles to prevent inadvertent shorts.
 - 4) Wear rubber gloves and boots.
 - 5) Do not lay tools or metal parts on top of the batteries.
 - 6) Determine if the battery is inadvertently grounded. If so, remove source of ground. Contact with any part of a grounded battery can result in electrical shock. The likelihood of such shock will be reduced if grounds are removed during installation and maintenance.

CAUTION

PRECAUTIONS FOR INSTALLATION

- **Do not block the intake/exhaust ports. Install the UPS at least 4" (10cm) away from walls, etc.**
 - If the intake/exhaust ports are blocked, the internal temperature of the UPS will rise and could lead to fires from battery electrolyte leakage, fire ignition or part deterioration.
- **Follow the UPS instruction manual carefully when installing the unit.**
 - Improper installation could lead to injury such as the UPS falling over, etc.

PRECAUTIONS FOR WIRING

- **The power supply for this unit must be single phase rated in accordance with the equipment data plate. It must be suitably grounded.**
 - Failure to ground the unit could lead to electrical shocks.

PRECAUTIONS FOR USE

- **If a unit fault, abnormal odor or noise occurs, turn off the UPS input switch.**
 - Failure to do so could lead to fires.
- **Do not insert blunt objects or fingers, etc., in the fan.**
 - Failure to observe this could lead to injuries.
- **Do not insert blunt objects or fingers, etc., into the unit's input/output section.**
 - Failure to observe this could lead to electrical shocks.
- **Ventilate the UPS surroundings.**
 - Failure to do so could lead to container rupture or to explosions from the gas generated from the battery system.
- **Prohibit smoking and the use of fire around the unit.**
 - Failure to do so could lead to injuries, damage or fires from explosions.
- **Do not place containers that have water or any liquids on the UPS.**
 - If the container tips over and the water or liquids spills, this could lead to electrical shocks and to fires in the UPS.
- **Do not sit on, step on or lean on the UPS.**
 - Failure to observe this could lead to injuries if the UPS tips over.

CAUTION

PRECAUTIONS FOR MAINTENANCE AND INSPECTION

- **The inside of the UPS must be inspected or repaired only by qualified personnel.**
 - Failure to observe this could lead to electrical shocks, injuries, burns, smoke generation or fires.
- **Periodically replace the battery (every 5 years).**
 - Batteries that have exceeded the replacement life could lead to fires from electrolyte leakage or fire ignition.
- **Contact the dealer or service company for unit maintenance and repairs, and for the replacement of defective parts.**
 - Opening the cover could lead to electrical shocks or burns.

PRECAUTIONS FOR BATTERY

- **If the battery ignites, do not use water to extinguish the fire. Instead, use a powder (ABC) fire extinguisher.**
 - Use of water could cause the fire to grow.
- **Toxic diluted sulfuric acid in the battery.**
 - If electrolyte leaks from the unit, avoid contact with the skin or clothes.
If electrolyte makes contact with the skin or clothes, wash it off thoroughly with clean water.
If electrolyte makes contact with the eyes, rinse immediately and thoroughly with clean water, and then see a doctor. The presence of sulfuric acid in the eyes could lead to blindness, and adherence to skin could lead to burns.

OTHER PRECAUTIONS

- **Never use or store the unit in the following types of environment:**
 - a) A location having a low or high temperature, or high humidity deviated from the ambient environment conditions described in the brochure or instruction manual.
 - b) A location submerged in water or where the unit could become wet from dripping water.
 - c) At an altitude higher than 5000 feet (1500 meters).
 - d) In direct sunlight.
 - e) Where organic solvents (gasoline, paint thinner, etc.) are stored.
 - f) A location that is dusty.
 - g) A location containing combustible gas, corrosive gas, salt or oil mist.
 - h) A location subject to vibration or impacts.
 - i) A location near devices that generate sparks or near heating elements.

1.0 INTRODUCTION

The Mitsubishi Uninterruptible Power Supply (UPS) is designed to provide many years of reliable power supply and protection from power failure, brown-outs, line noise, and voltage transients. To ensure optimum performance of the equipment, follow the manufacturer's instructions accordingly. This manual contains descriptions for the installation and operation procedures of the UPS. Please read this manual carefully and retain it for future reference.

**IMPORTANT SAFETY INSTRUCTIONS
RETAIN THESE INSTRUCTIONS**



This manual contains important instructions for the 7011A Series Uninterruptible Power Supply Systems that should be adhered to during installation, operation and maintenance of the UPS and batteries.

WARNING 1



**Lethal voltages exist within the equipment during operation.
Observe all warning and cautions in this manual.
Failure to comply may result in serious injury or death.
Obtain a qualified service for this equipment as per instructions.**

WARNING 2

This UPS does not include an AC input circuit breaker (MCCB) to protect the bypass and main input circuit. The AC input circuit breaker (MCCB) is to be field supplied and installed. Circuit breaker (MCCB) specifications are as follows:

Capacity (kVA)	AC input Voltage (Vac)	AC input Rating (Aac)	Recommended Breaker (A)
6	208	26.4	35
8	208	35.2	45
10	208	44.0	60
12	208	52.8	70

AC output and DC input overcurrent protection and disconnection devices shall be field supplied and installed.

1.1 GENERAL

The Mitsubishi 7011A Series UPS is designed to provide continuous and clean electrical power to a critical load. In the event of an input power failure, the UPS will supply power to the critical load for the specified battery time.

If the input power is not restored promptly, backup power from the UPS battery permits the orderly shutdown of equipment supported by the UPS. The UPS is simple to start up, operate and maintain.

The 7011A Series UPS is available in four (4) kVA sizes: 6, 8, 10 and 12kVA. Specifications for each kVA model appear in Section 1.4. All models have batteries included in the UPS module cabinet. The principles of operation described herein are applicable to all models.

This manual provides an overview of the 7011A Series components and their functions. The appearance and purpose of operator controls and indicators is described with procedures for operation, start-up, shutdown and basic maintenance included.

1.2 DEFINITIONS

UNINTERRUPTIBLE POWER SUPPLY SYSTEM (UPS) - All components within the UPS Module Cabinet and associated batteries which function as a system to provide continuous, conditioned AC power to a load. This is sometimes referred to as the "System".

UPS MODULE CABINET - The metal enclosure which contains Converter & Inverter Module, I/O Module, batteries, and operator controls required to provide specified AC power to a load.

CONVERTER & INVERTER MODULE - The Converter / Charger and Inverter assembly which, under the direction of the I/O Module and operator controls, provide specified AC power to a load.

I/O MODULE – Assembly which contains Static Transfer Switch, the internal bypass line, and the internal control system. With operator controls, gives directions required to the Converter & Inverter Module to provide specified AC power to a load.

CONVERTER / CHARGER - The UPS component which contain the equipment and controls necessary to convert input AC power to regulated DC power required for battery charging and for supplying power to the Inverter.

INVERTER – The UPS component which contain the equipment and controls necessary to convert DC power from the Converter / Charger, or the battery, to AC power required by the critical load.

STATIC TRANSFER SWITCH - Device which connects critical load to the bypass line when the Inverter cannot supply continuous power.

MAINTENANCE BYPASS LINE - Line which conducts electricity directly from the input power source to the critical load during maintenance or whenever the UPS is not completely operational.

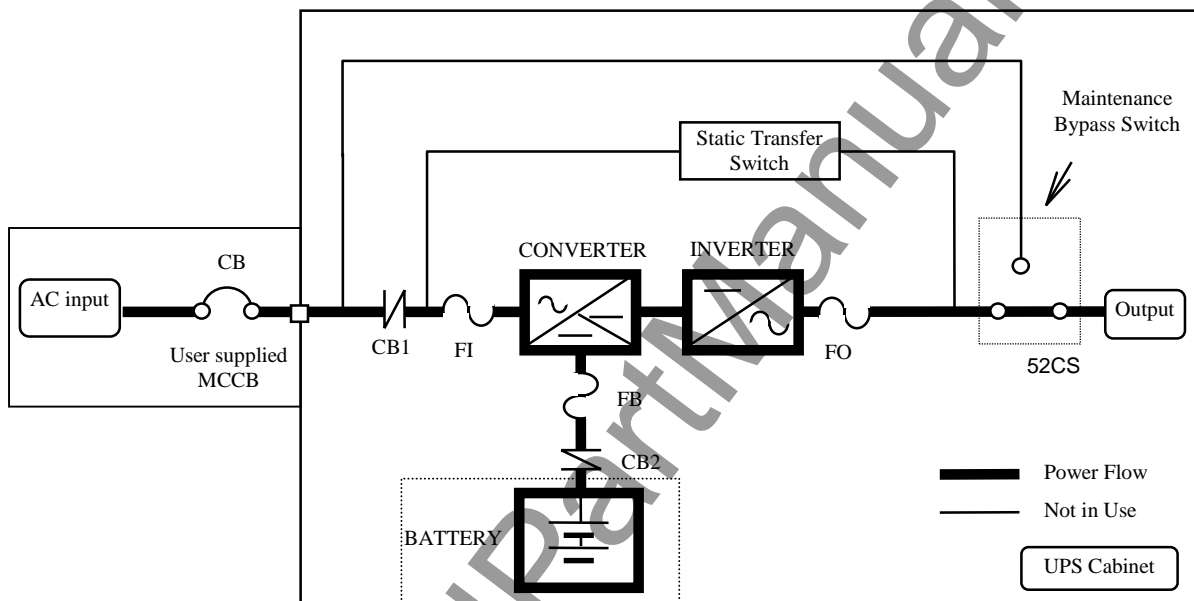
AC INPUT POWER - Power provided by the electrical utility company, or auxiliary generator, which is connected to the UPS for supplying critical load and recharging the battery.

BATTERY - Rechargeable battery strings which supply DC power to the inverter to maintain continuous AC power to the load during AC input power failure conditions.

1.3 OVERVIEW

The UPS provides two power paths between the utility source and the critical load. Figure 1.1 shows the path for normal operation, with the load powered from the inverter. Figure 1.2 shows the path for bypass operation, with the load supplied through the static bypass line.

FIGURE 1.1 Single Line Diagram - Normal Operation. Load powered by inverter.



During normal operation, the path through the inverter is used to power the load.

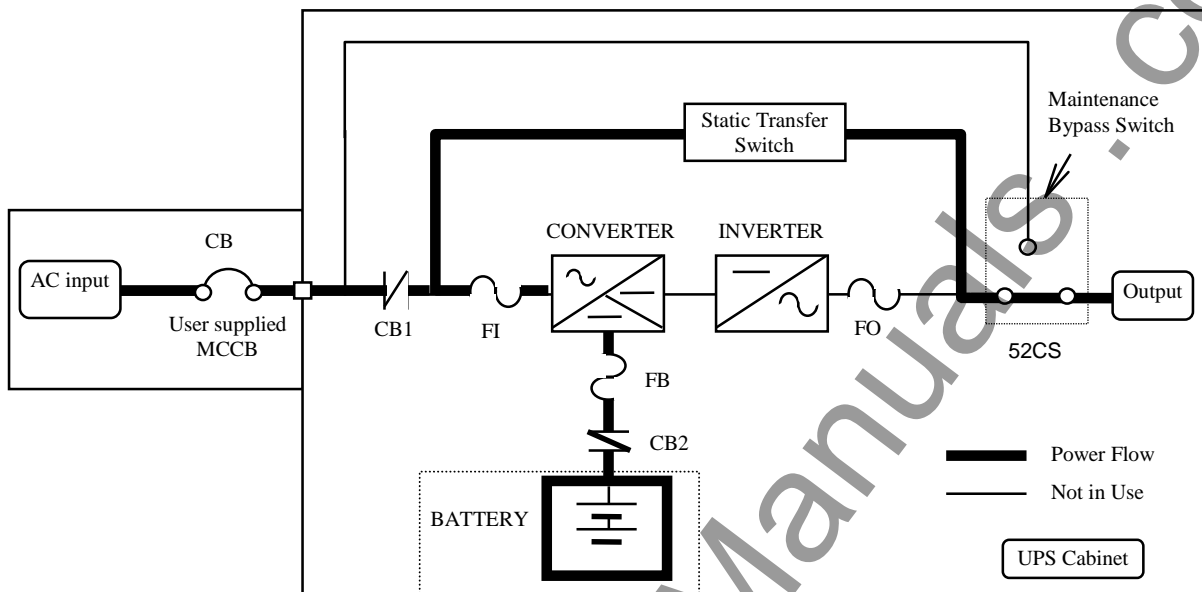
Referring to Figure 1.1: Input AC power is converted to DC by the Converter. DC power is utilized to charge the UPS battery and to provide power to the Inverter. The Inverter converts the DC power to clean AC power to supply the critical load.

The conversion - inversion process eliminates any voltage transients or fluctuations existing in the input power before it reaches the critical load.



*** The Input circuit breaker(MCCB) for protection of the UPS and cables are field supplied and field installed. (See WARNING 2 in section 1.0).**

FIGURE 1.2 Single Line Diagram - Bypass Operation. Load fed through static bypass line.



Referring to Figure 1.2, the Internal Static Bypass line is a hard-wired line which supplies the critical load with unconditioned input power. The purpose of this line is to route power to the critical load while the UPS module is de-energized (converter and inverter), and during Start-up before the system is fully operational.

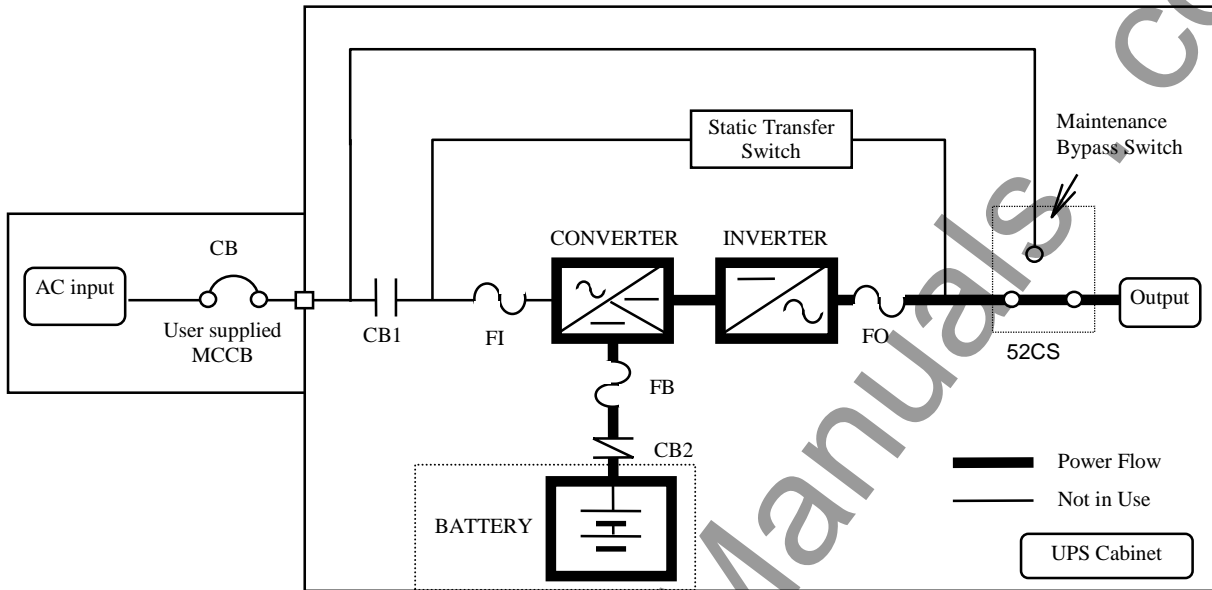
The internal control system determines the operation of the two paths, with the load powered from the inverter being the normal operation.

Referring to Figure 1.3, if the input power is interrupted, the battery will immediately supply the DC power required by the Inverter to maintain continuous AC power to the load. A fully charged battery will provide power for the specified time at the rated load, or longer at reduced load.

When power is restored after a low battery shutdown, the Converter automatically restarts operation, recharges the batteries and the Inverter is automatically restarted without operator intervention. The load is assumed by the inverter automatically without operator intervention.

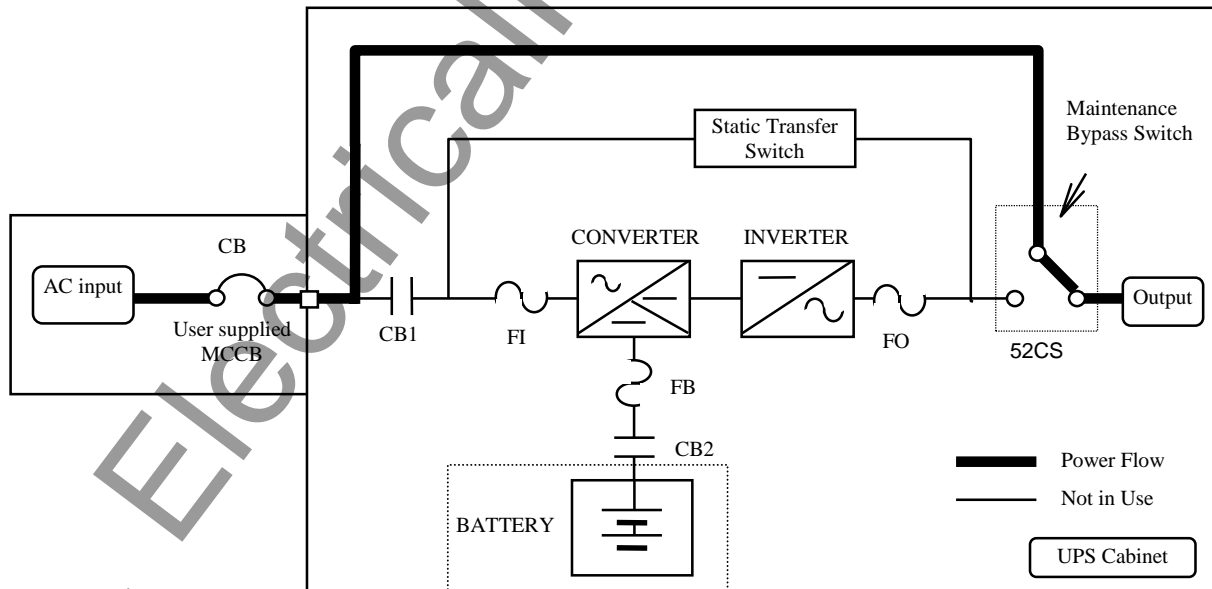
In the event of a power failure, the Converter will de-energize and the batteries will discharge into the Inverter and maintain power to the critical load until a) the battery capacity expires and the inverter turns off, or b) input power is restored after which the converter will power the inverter and simultaneously recharge the batteries. Figure 1.3 illustrates the flow diagram during battery operation.

FIGURE 1.3 Single Line Diagram - Battery Operation



The UPS is equipped with an internal rotary type Maintenance Bypass Switch (MBS) that can be used to divert utility power to the load during maintenance sessions. Figure 1.4 illustrates the power path when the MBS is in the BYPASS mode.

FIGURE 1.4 Single Line Diagram - UPS on Maintenance Bypass Operation.



The rotary maintenance bypass switch is shown as 52CS in Figure 1.4. 52CS is a two position four point make-before-break transfer switch.

The two positions are identified as NORMAL and BYPASS. In the NORMAL position the load is fed by the UPS - either through the inverter or through the static bypass line. In the BYPASS position the load is powered by an external source such as the utility or a generator. This transfer operation must be made while the UPS is in the static bypass mode.

For transfer procedure to place the UPS in maintenance bypass mode, or from bypass mode to normal operation mode, refer to section 3.6 Maintenance Bypass Set-up Procedures.

(For Service Personnel Only)

FIGURE 1.5 UPS Parts Location(6kVA)

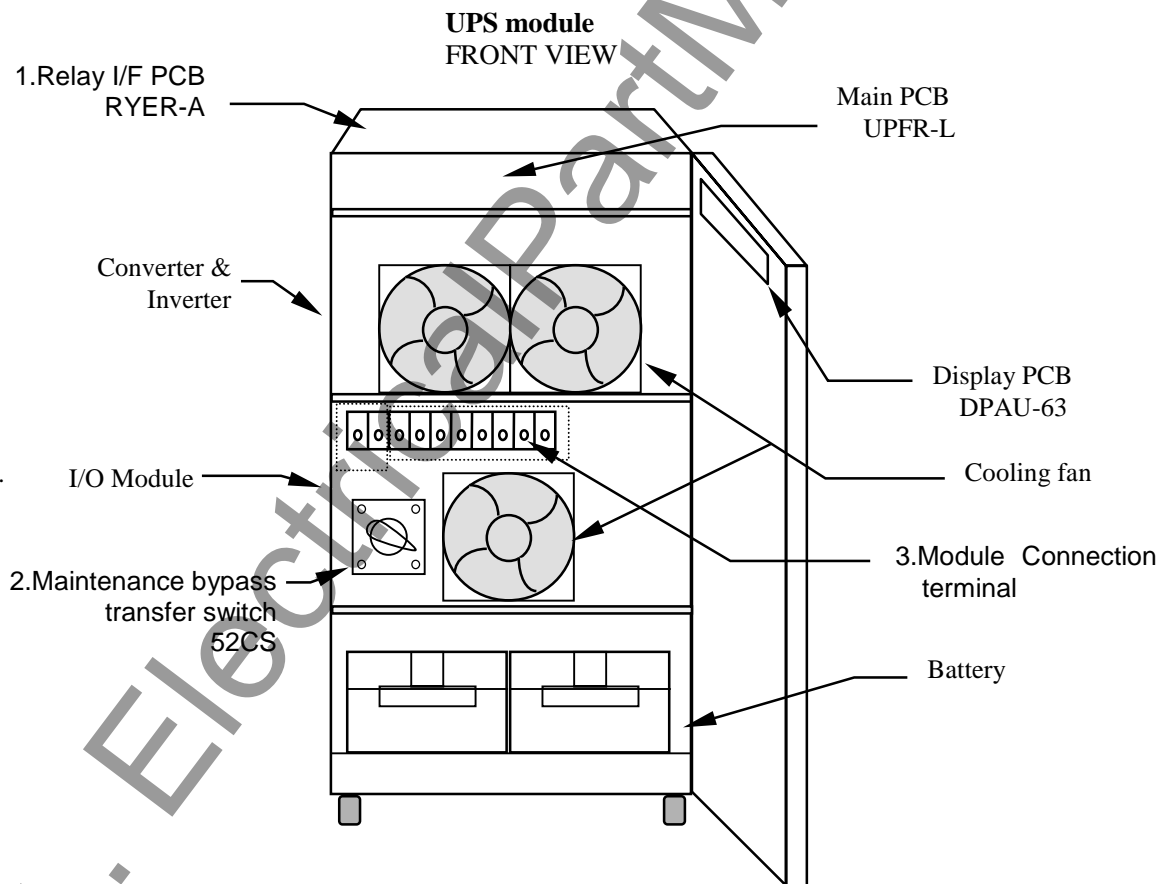


FIGURE 1.6 UPS Parts Location(8,10 and 12kVA)

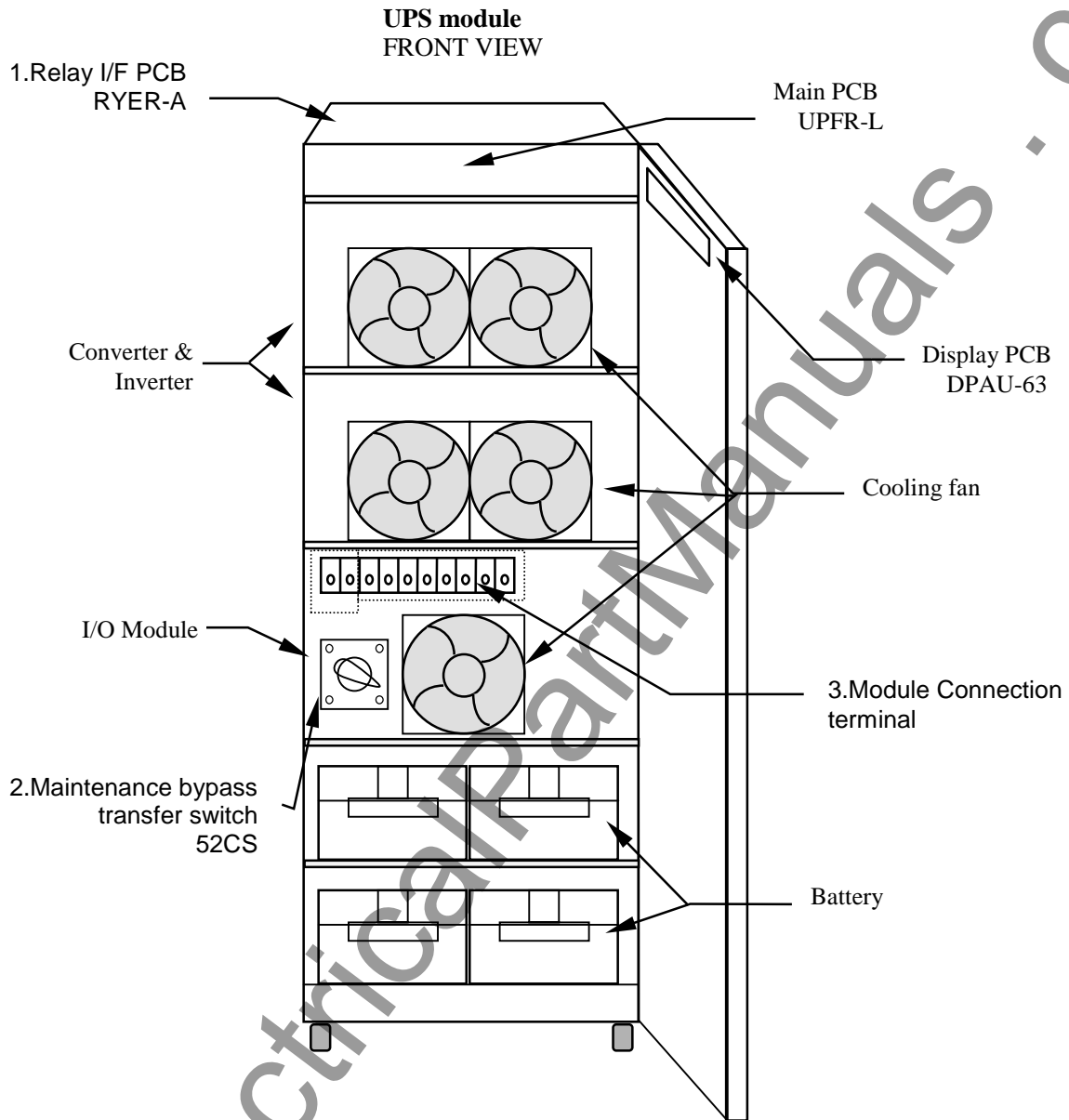


FIGURE 1.7 UPS Parts Location (Rear view)

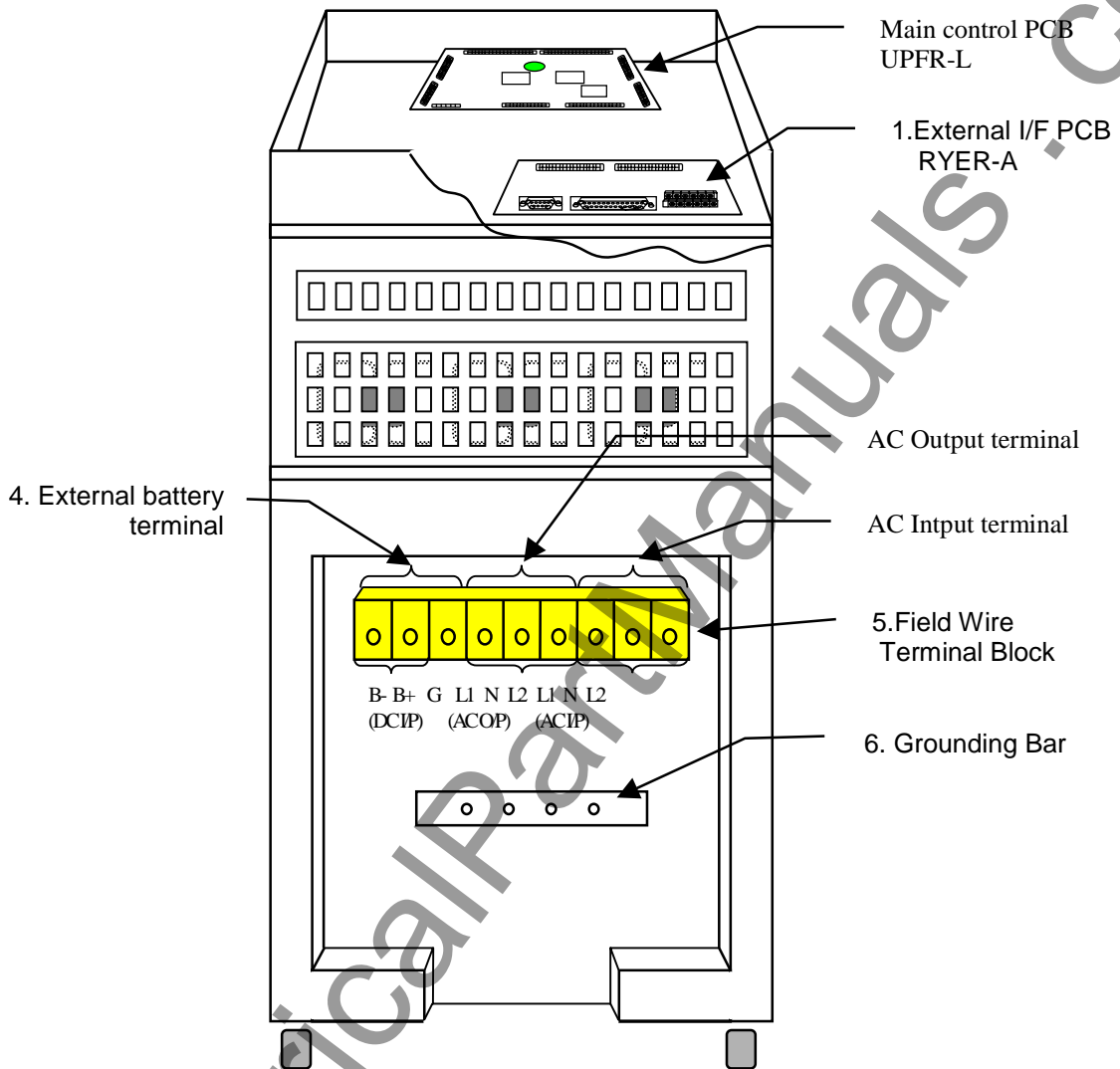
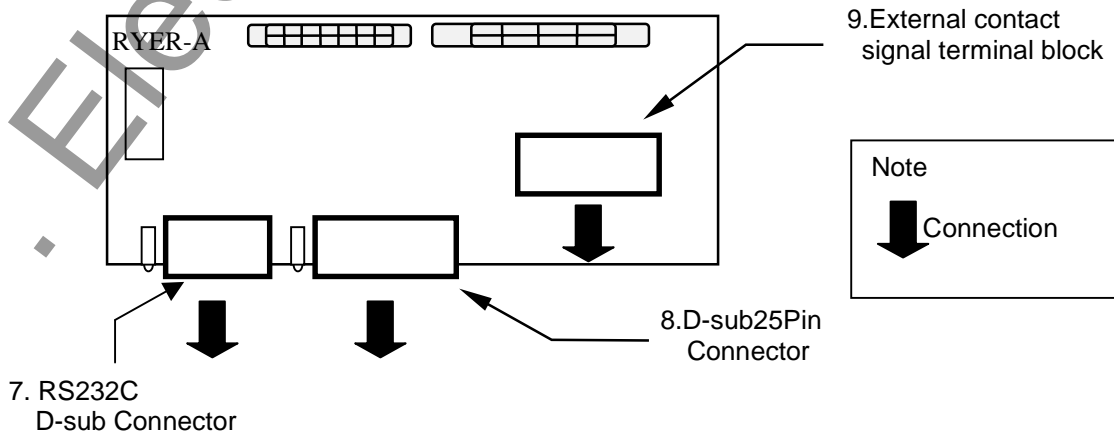


FIGURE 1.8 External I/F PCB RYER-A



Description of UPS parts, referred to in Figure 1.5 to Figure 1.8:**1. Relay PCB RYER-A board**

Signal I/F on RYER-A board : (Figure 1.8):

- (7) RS232C communication connector
- (8) D-Sub 25 Pin connector
- (9) External contact signal terminal block

2. Maintenance Bypass Switch (52CS) (FOR SERVICE PERSONNEL ONLY)

This switch is used to transfer the load from inverter power to external power for maintenance purposes. Do not operate it under normal operation.

3. Module Connection terminal (FOR SERVICE PERSONNEL ONLY)

Terminal block to connect each module.

4. External Battery terminal (FOR SERVICE PERSONNEL ONLY)

Terminal block to connect the external battery cabinet.

5. Field Wire Terminal Block (FOR SERVICE PERSONNEL ONLY)

Refer to Figure 3.3 and Figure 3.4 for details

6. Grounding Bar**7. RS232C connector**

Refer to Figure 2.8 for detail.

8. D-Sub 25 Pin connector

Refer to Table 2.1 for detail.

9. External Contact Signal Terminal Block

Terminal block to connect contact signal input/output lines to and from external dry contacts.
Refer to Table 2.2 for details.

1.4 SPECIFICATIONS

The UPS name plate displays the rated kVA as well as nominal voltages and currents. The name plate is located on the interior side of the UPS front door.

TABLE 1.1 Power Specifications

Rated output Power	Input voltage 1 ph 3 wire or 2 ph 3 wire	Output voltage 1 ph 3 wire or 2 ph 3 wire
6kVA / 4.2kW	240/120, 208/120	240/120, 208/120
8kVA / 5.6kW	240/120, 208/120	240/120, 208/120
10kVA / 7.0kW	240/120, 208/120	240/120, 208/120
12kVA / 8.4kW	240/120, 208/120	240/120, 208/120

TABLE 1.2 UPS Module Information

UPS (kVA)	CABLE ENTRY	WIDTH (in/mm)	DEPTH (in/mm)	HEIGHT (in/mm)	WEIGHT* (lb./kg)	HEAT LOSS @ 208V (kBTU/h)
6	REAR	13.8 / 350	29.9 / 760	27.8 / 705	307/140	2.2
8	REAR	13.8 / 350	29.9 / 760	40.6 / 1030	507/230	2.9
10	REAR	13.8 / 350	29.9 / 760	40.6 / 1030	507/230	3.6
12	REAR	13.8 / 350	29.9 / 760	40.6 / 1030	507/230	4.3

* Including batteries

TABLE 1.3 Rating of Contactors and Fuses

Component(s)	Description	Component Rating @ 208V, 3 phase, 60 Hz			
		UPS Rating	6 kVA	8 kVA	10 kVA
CB1	AC Input Contactor	80A	80A	80A	80A
CB2	DC Input Contactor	32A	60A	60A	60A
FCR, FCS	AC Input Fuse	80A/240V	80A/240V	80A/240V	80A/240V
FIU, FIV	Inverter Output Fuse	80A/240V	80A/240V	80A/240V	80A/240V
FUBU, FUBV		30A/600V	30A/600V	30A/600V	30A/600V
FD1, FD3	UMAR-A	40A/660V	80A/660V	80A/660V	80A/660V
FD2	UMAR-A	80A/500Vdc	80A/500Vdc	80A/500Vdc	80A/500Vdc

TABLE 1.4 Detail of Specifications

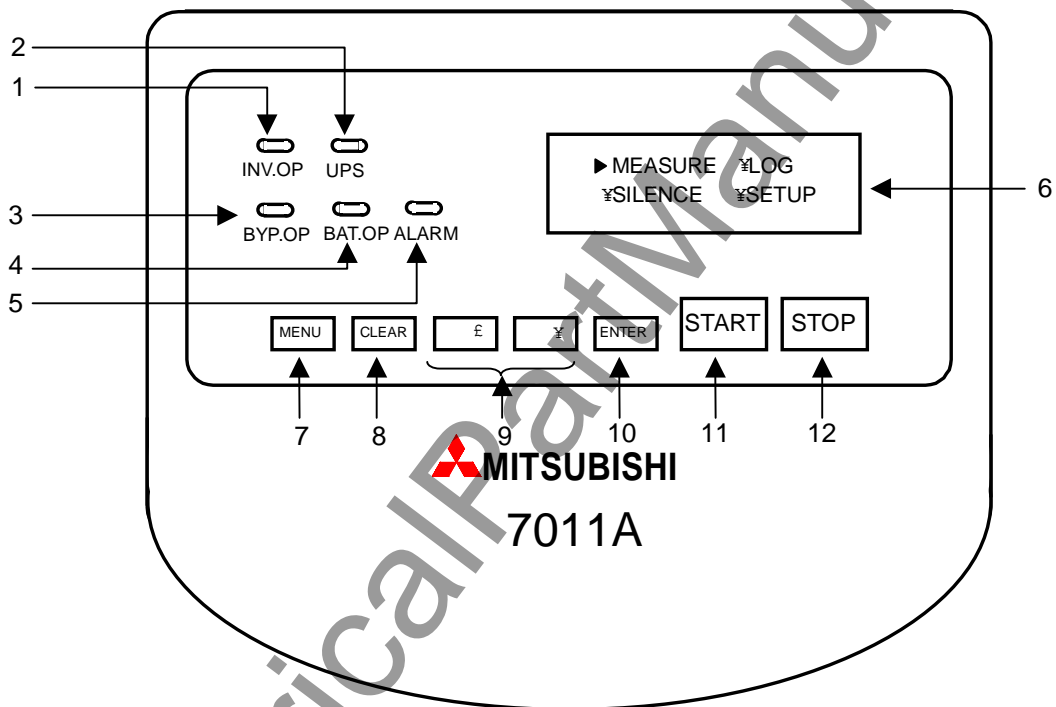
Rated Output kVA	6	8	10	12
Rated Output kW	4.2	5.6	7.0	8.4
AC INPUT CHARACTERISTICS				
Configuration	1 phase 3 wire or 2 phase 3 wire			
Voltage	240/120V (1 phase), 208/120V (2 phase)			
Frequency	50 / 60 Hz +/-5%			
Reflected Current THD	4% typ. at 100% load; 7% typ. at 50% load			
BATTERY				
Type	VRLA			
Ride Through	10min. at 100% load	15min. at 100% load	12min. at 100% load	10min. at 100% load
Nominal Voltage	216 Vdc			
Minimum Voltage	173 Vdc			
Number of Cells	108			
AC OUTPUT				
Configuration	1 phase 3 wire or 2 phase 3 wire			
Voltage	240/120V (1 phase), 208/120V (2 phase)			
Voltage Stability	+/-2% steady state			
Frequency	50 / 60 Hz			
Frequency Stability	+/-0.01% in free running mode			
Power Factor	0.7 nominal			
Power Factor range	0.7 ~ 1.0 lagging (within output kW rating)			
Voltage THD	2% typical THD at 100% Linear Load 5% typical THD at 100% non-linear load			
Transient Response	+/-3% typical at 100% load step +/-1% typical at loss/return of AC power +/-3% typical at load transfer to/from static bypass			
Transient Recovery	50 ms			
Voltage Unbalance	2% typical at 100% unbalanced load			
Phase Displacement	1deg. typical at 100% load			
Inverter Overload	150% for 1 minute			
System Overload	150% for 1 minute, 1000% for 1 cycle (with bypass available)			
Bypass Overload	150% for 1 minute, 1000% for 1 cycle			
Crest Factor Capabilities	3:1			
ENVIRONMENTAL				
Cooling	Forced Air			
Operating Temperature	32°F ~ 104°F (0°C ~ 40°C). Recommended 59°F ~ 77°F (15°C ~ 25°C)			
Relative Humidity	5% ~ 95% Non Condensing			
Altitude	0 ~ 9000 feet No Derating			
Location	Temperature-controlled, indoor area free of conductive contaminants			

2.0 OPERATOR CONTROLS AND INDICATORS

The 7011A Series operator controls and indicators are located as follows:

Maintenance bypass switch and contactors : Inside the unit
 UPS status indicators : Door exterior


FIGURE 2.1 Operation/Display Panel (Front panel)



2.1 STATUS INDICATORS

- 1) **Load on inverter [INV OP.] (green)**
Illuminated when power is supplied from inverter to the critical load.
- 2) **[UPS] (green)**
Illuminated when UPS is ready to supply load.
- 3) **Load on bypass [BYP OP.] (yellow)**
Illuminated when power is supplied to load devices by static bypass.
- 4) **Battery operation [BAT OP.] (yellow)**
Illuminated when the battery is operating following an AC power failure.
- 5) **[ALARM] (red)**
Illuminated when UPS is in fault mode, input abnormal, or overload.
- 6) **Liquid Crystal Display (LCD)**
During operation, LCD displays as shown in figure 2.2.
For details of LCD displays, refer to "2.2 LCD DISPLAY".

FIGURE 2.2 LCD Display During Normal Operation

OUT: 120V 60.0Hz
BATTERY: 

When UPS is operating normally, LCD shows output voltage, frequency, and amount of battery left.

FAILURE
PRESS MENU->LOG

When there's a failure in the UPS, LCD shows the display on the left.

EVENT CODE 806
OVER LOAD

When there's a failure in the UPS resulting from false operation such as overload, LCD shows code no. and status of the failure .

- 7) **Menu [MENU] (gray)**
When pressed, displays NORMAL MODE Menu Window on the LCD. When pressed simultaneously with ENTER key (1 sec.), will display USER SETUP MODE Menu Window.
- 8) **Clear [CLEAR] (gray)**
When pressed, will return to the upper level window on the LCD.
- 9) **Up/Down [\blacktriangle \blacktriangledown] (gray)**
When pressed, will select the previous/next choice, or decrease/increase the number of the chosen status on the LCD.

10) Enter [ENTER] (gray)

When pressed, will fix the displayed value, and/or display the next window.

11) UPS start [START] (green)

UPS start button. When pressed, the UPS starts to load from the inverter.

12) UPS stop [STOP] (red)

UPS stop button. When pressed, the UPS can be stopped.

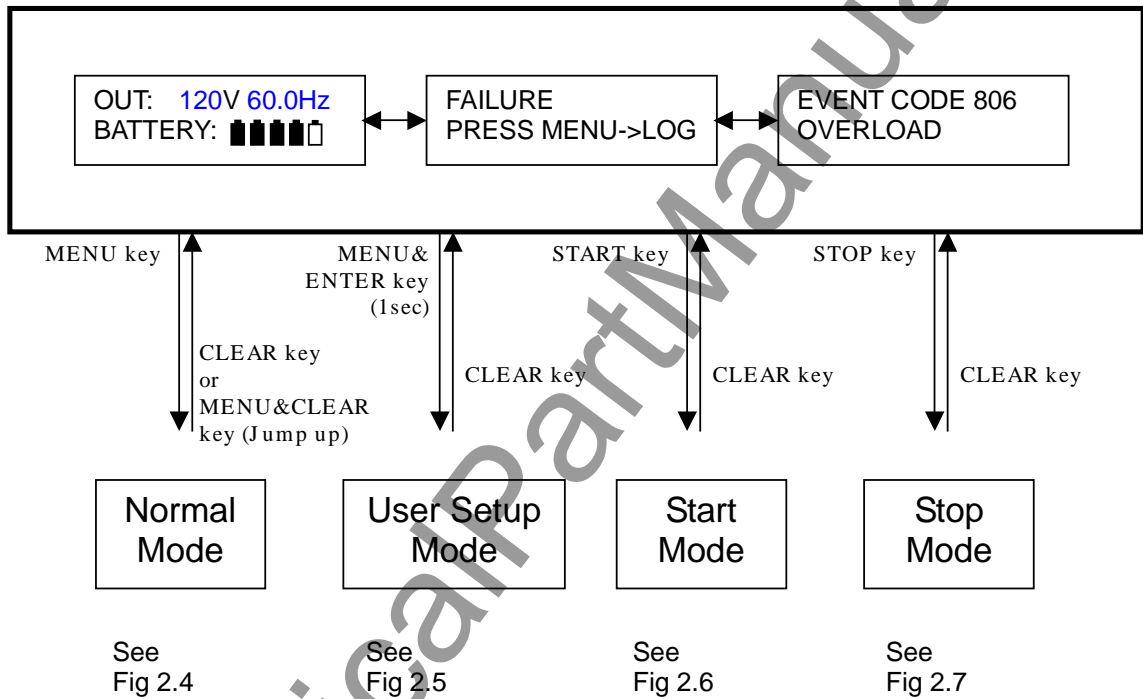
When pressed, will display Stop Mode Window. Then if pressed simultaneously with ENTER button, the UPS will stop operation.

2.2 LCD DISPLAY

Followings are tree diagrams of LCD display.

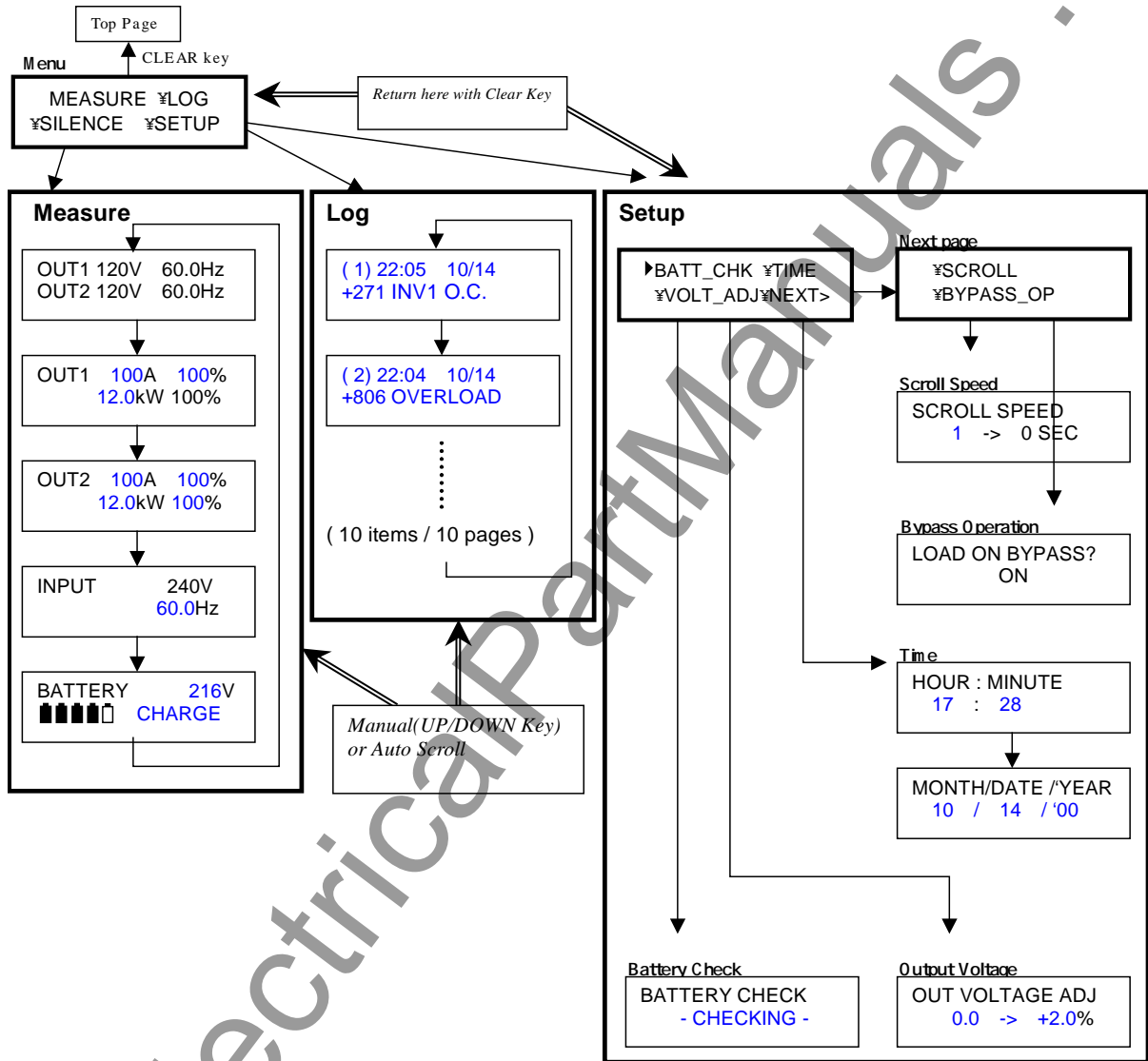
A) Top Page

FIGURE 2.3 Tree Diagram of LCD display (Top Page)



B) Normal Mode

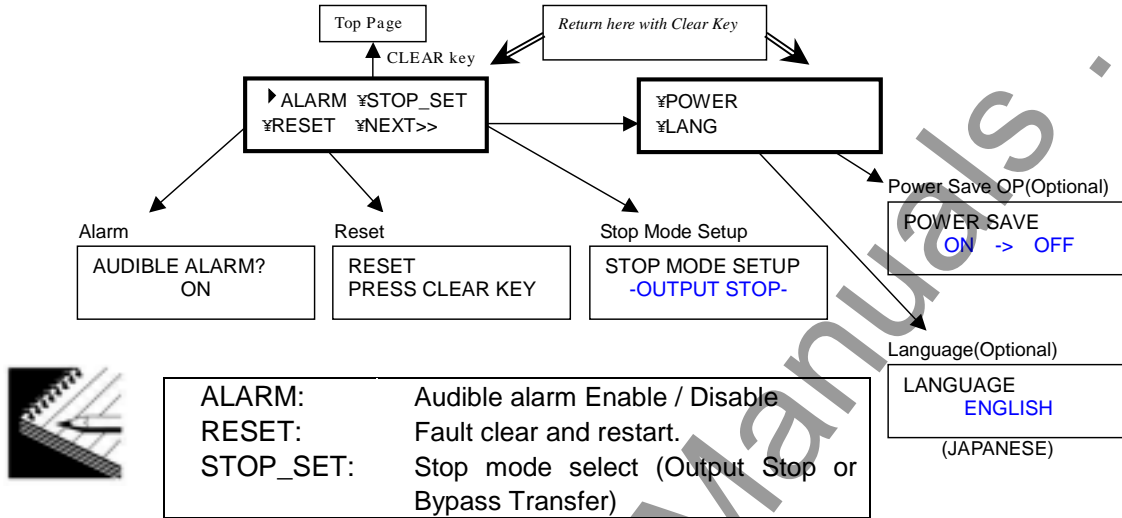
FIGURE 2.4 Tree Diagram of LCD Display (Normal Mode)



Measure	OUT1:	L1-N
	OUT2:	L2-N
Log	+ [code]:	Occurred
	- [code]:	Cleared
Set up	BATT_CHK	Start the self battery test operation.
	TIME	Set the day and time.
	VOLT_ADJ:	Adjust the output voltage.
	SCROLL:	Set the log page scroll speed.
	BYPASS_OP:	Select the output source.

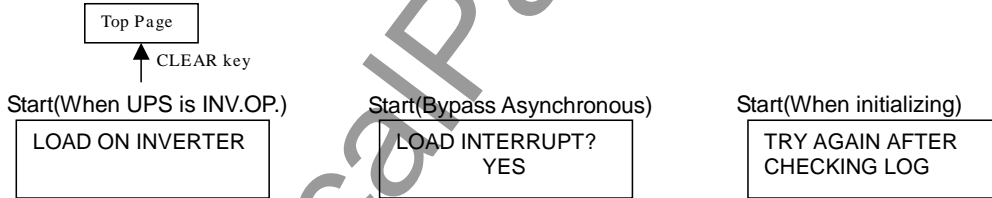
C) User Setup Mode

FIGURE 2.5 Tree diagram of LCD Display (User Setup Mode)



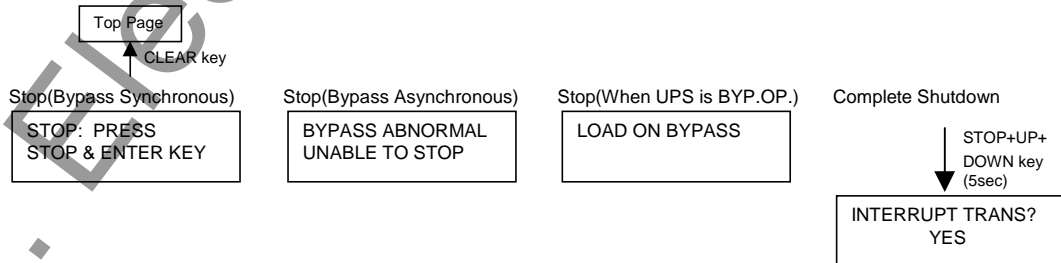
D) Start Mode

FIGURE 2.6 Tree Diagram of LCD Display (Start Mode)



E) Stop Mode

FIGURE 2.7 Tree Diagram of LCD Display (Stop Mode)

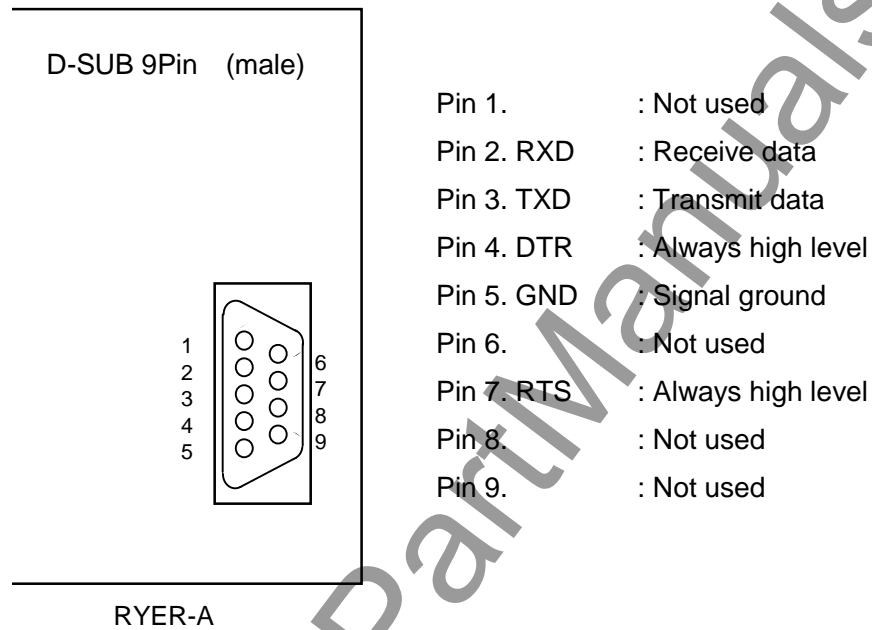


When “Complete Shutdown” procedure is executed, all the output power from the UPS will be shut off.

2.3 RS232C CONNECTOR (External communication connector)

This is an RS232C port for “Diamond-Link”^{*} monitoring software. The layout of the connector is shown in Figure 2.8. Connections not to exceed NEC Class 2.

FIGURE 2.9 RS-232C Connectors



** Consult MITSUBISHI ELECTRIC AUTOMATION, INC. for detail on “Diamond Link” monitoring software and its capabilities.*

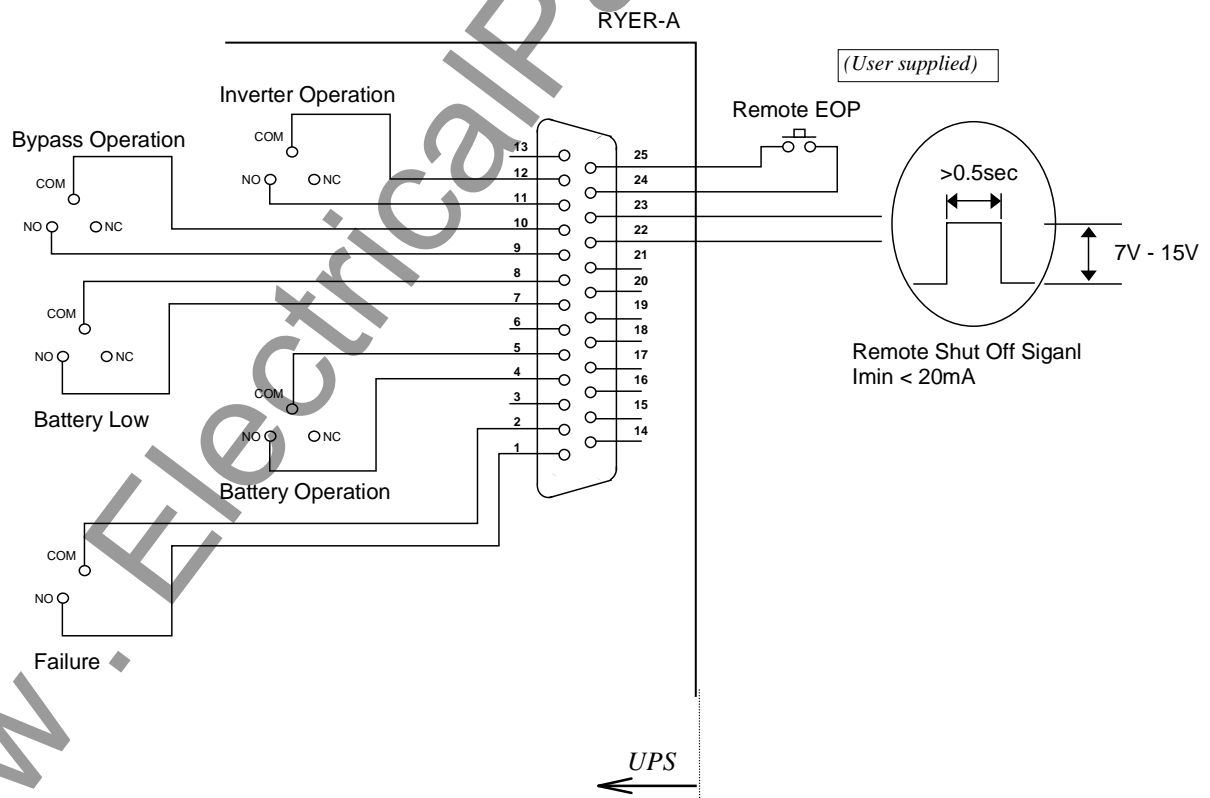
2.4 D-SUB 25 PIN CONNECTOR

Uses dry contact on/off to express NORMAL, FAULT, ON BATTERY, BATTERY LOW, ON BYPASS, ON INVERTER status. Connections not to exceed NEC Class 2.

TABLE 2.1 D-Sub 25 Pin connector

Pin No.	Signal	I/O	Pin No.	Signal	I/O
1	Failure A Contact	Output	14		Output
2	Failure A Contact com	Output	15		Output
3		Output	16		Output
4	Battery Operation A Contact	Output	17		Output
5	Battery Operation com	Output	18		Output
6		Output	19		Output
7	Battery Low Voltage A Contact	Output	20		Output
8	Battery Low Voltage A Contact com	Output	21		Output
9	Bypass Operation A Contact	Output	22	Shut Off	Input
10	Bypass Operation A Contact com	Output	23	Shut Off common	Input
11	Inverter Operation A Contact	Output	24	RE-EPO	Input
12	Inverter Operation A Contact com	Output	25	RE-EPO common	Input
13		Output			

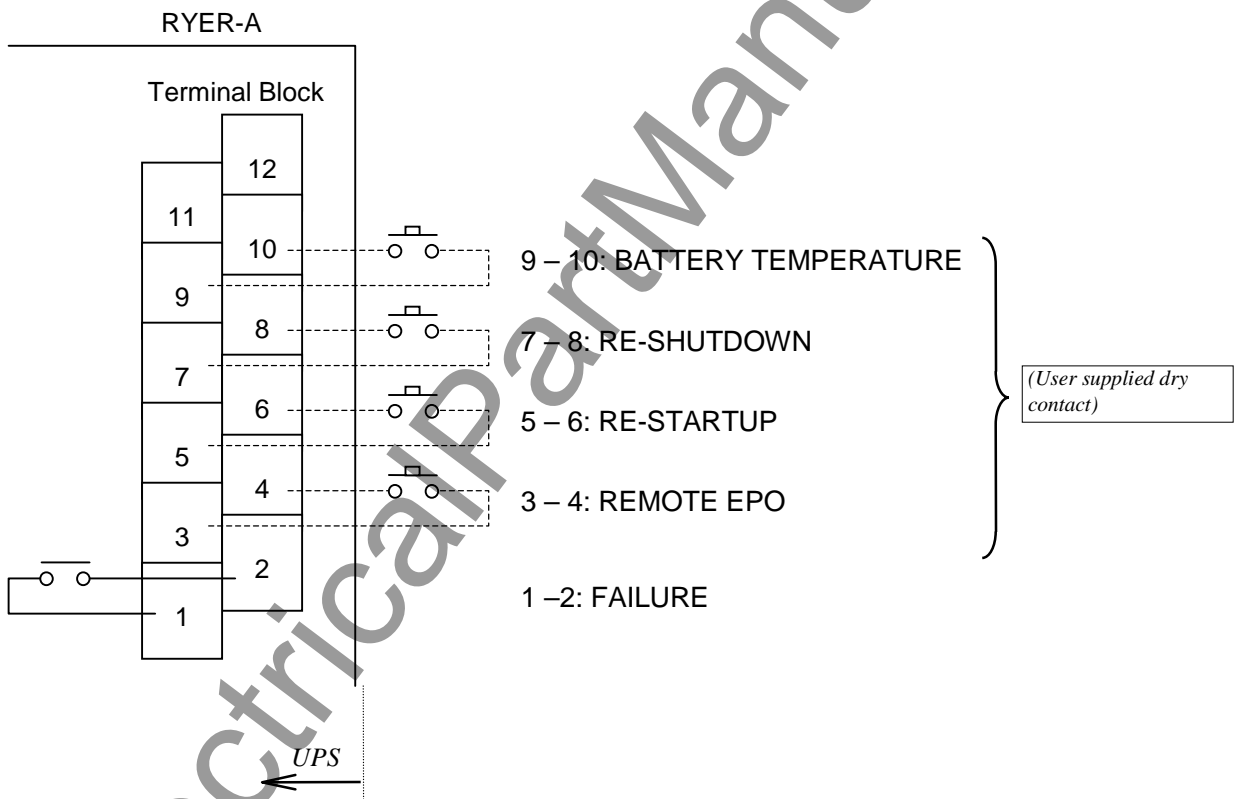
FIGURE 2.10 D-sub 25 Pin Connectors



2.5 EXTERNAL SIGNAL TERMINAL BLOCK (Option)

The UPS is equipped with a series of input/output terminals for the external annunciation of alarms and the remote access of certain UPS functions. A functional description of the input/output port is presented below. Layout of terminals is shown in Figure 2.10. Connections not to exceed NEC Class 2.

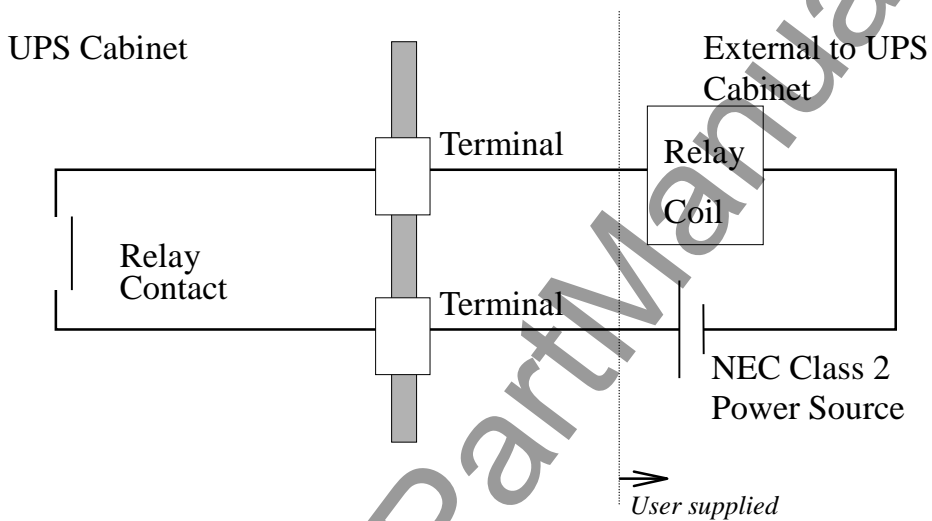
FIGURE 2.11 External Signal Terminal Block



A) Output Contacts(for external alarm annunciation)

Output contacts consist of form “A” dry type contacts. Rated capacity of all output contacts is 30Vdc/1Adc. Operate all dry contacts at their rated values or lower. Figure 2.11 illustrates typical installation. The external relay can also be a lamp, LED, computer, etc.

FIGURE 2.12 Control Wiring for External Contacts



NOTE: *The UPS is equipped with a selectable output contact feature. The above alarms are the default settings. Contact **MITSUBISHI ELECTRIC AUTOMATION, INC.** for setup information.*

B) Input Contacts(for remote access of UPS)

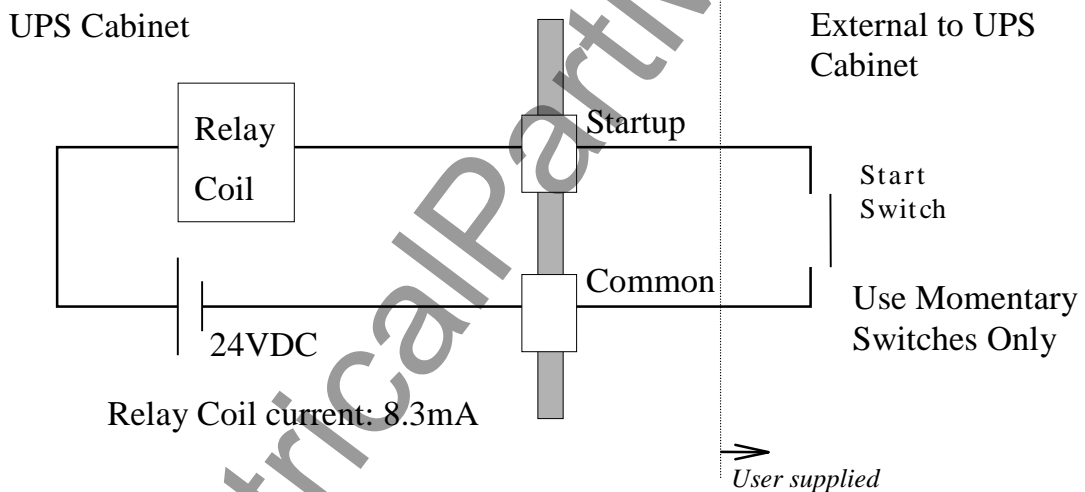
External contacts are provided by the user of the UPS system. Terminal voltage at the UPS is 24Vdc. Provide external dry contact accordingly.



CAUTION: *Do not apply voltage to remote access input terminals. Damage to UPS may result.*

Refer to Figure 2.12 for typical wiring configuration. Although this figure applies to the RE-STARTUP terminals, the same wiring arrangement is used for RE-EPO; RE-SHUTDOWN, Battery temperature.

FIGURE 2.13 Remote "Startup" Contact Connections



NOTE: *In all cases, a switch having a protective cover is recommended in order to reduce possibility of accidental operation.*

3.0 INSTALLATION AND OPERATION

3.1 TRANSPORTATION AND INSTALLATION

TABLE 3.1 How to transport and install the system

Transportation	Installation
Transport unit with forklift.	Pull out the UPS cabinet as shown in Figure 3.1 Fix the UPS unit in place using the four (4) leveling

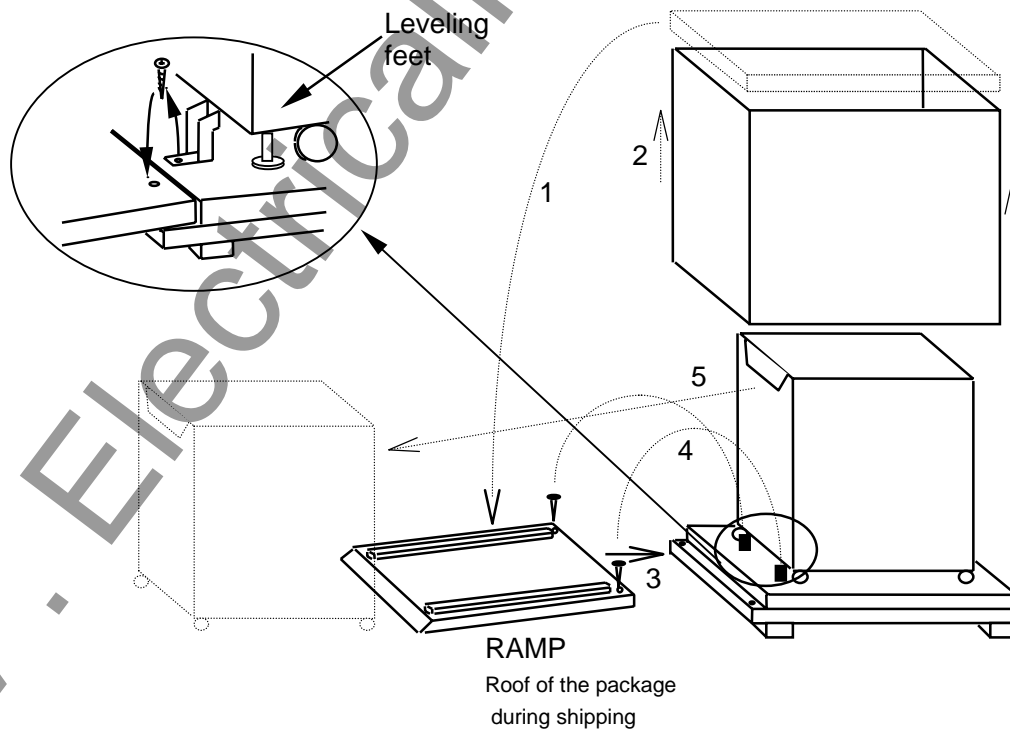


NOTE: Do not transport in a horizontal position. Cabinets should be maintained upright within +/- 15° of the vertical during handling.

3.2 HANDLING

The UPS is shipped in export packaging. Remove the UPS from the package only when it is ready for installation. Refer to Figure 3.1 for handling.

FIGURE 3.1 Handling



3.3 INSTALLATION PROCEDURE

A) Note the load tolerance of the floor

Refer to TABLE 3.1 for list of UPS weights:

TABLE 3.1 List of UPS weights (lb.)

UPS Capacity (kVA)	6	8	10	12
Weight (lb.)	307	507	507	507

B) Minimum clearance required for ventilation

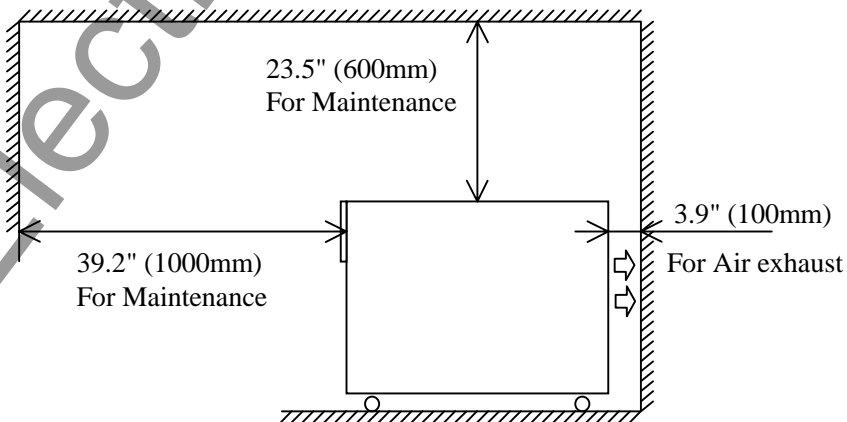
- Right side 1.2" (30 mm) (not required when sidecars are used)
- Left side 1.2" (30 mm) (not required when sidecars are used)
- Back side 3.9" (100 mm)
- Top side 23.5" (600 mm)

C) Space requirement for routine maintenance

Allow for the following space at the time of installation.

- Front 39.2" (1000 mm)
- Sides 1.2" (30 mm)
- Rear 39.2" (1000 mm)
(3.9" (100mm) when cable connected at the rear side is drawn from the front side)

FIGURE 3.1 Clearance for ventilation and maintenance



3.3 PROCEDURE FOR CABLE CONNECTION (Refer to Table 3.2 for cable sizes.)

- 1) Confirm the capacity of the UPS being installed. Identify the field terminal blocks as shown in the appropriate Figure 3.2 or Figure 3.3-Figure 3.5.
- 2) Referring to Figure 3.4-Figure 3.5., connect the grounding conductors from the input service entrance to the UPS ground bar.
- 3) Confirm that an external input circuit breaker sized to protect both the rectifier input and the bypass lines is installed. Consult equipment nameplate for current ratings.
- 4) Connect the AC power source cables from the input service entrance to the UPS" INPUT power terminals identified as L1, N, and L2 in Figure 3.3-Figure 3.5. Input cables must be sized for an ampere rating larger than the maximum current capacity of the UPS. Refer to Table 3.2 for recommended cable sizes.
- 5) Refer to Table 3.2 for recommended cable sizes. Referring to Figure 3.3-Figure 3.5, connect UPS OUTPUT load terminals L1, N, and L2 to load distribution panel.
- 6) UPS equipment does not employ AC output overcurrent protection or disconnection devices and must be provided at installation.
- 7) UPS equipment does not employ DC input overcurrent protection or disconnection devices and must be provided at installation.
- 8) Connect external signal terminal block as needed. Refer to section 2.3 and Figure 2.9 for functional description. 12 AWG or less, shielded conductor is recommended.
- 9) Connect external Battery
Refer section 3.4.1.
- 10) Connect internal battery connector(s).



CAUTION: *UPS power terminals are supplied with stud type fittings. It is recommended that compression lugs be used to fasten all input/output power cables. Refer to Table 3.3 for recommended compression lugs and appropriate crimping tool*

TABLE 3.2 Recommended Cable Size and Torque Requirements

UPS Capacity (kVA)	Input Side *1		Output Side *1	
	Cable Size	Torque (in. lbs)	Cable Size	Torque (in. lbs)
6kVA (208V)	10 AWG *2 or larger	80 in. lbs	10 AWG *2 or larger	80 in. lbs
8kVA (208V)	8 AWG *2 or larger	80 in. lbs	8 AWG *2 or larger	80 in. lbs
10kVA (208V)	6 AWG *2 or larger	80 in. lbs	6 AWG *2 or larger	80 in. lbs
12kVA (208V)	6 AWG *2 or larger	80 in. lbs	6 AWG *2 or larger	80 in. lbs

*1 - Voltage drop across power cables not to exceed 3% of nominal source voltage.

*2 - Allowable ampere ratings based on 90 °C insulation at an ambient temperature of 40 °C.

No more than 3 conductors in a raceway without de-rating. Use copper conductors rated 90°C.

TABLE 3.3 Crimp Type Compression Lug

Wire Size (Code)	Wire Strand Class	Recommendation		Crimp tool required BURNDY type Y35 or Y46	
		Vendor	Cat. No.	Color key	Die index
10	B	BURNDY	YAV10 T3BOX	-	-
8	B	BURNDY	YA8C-L1 BOX	RED	49
6	B	BURNDY	YA6C-L BOX	BLUE	7 / 374



NOTE: When using crimp type lugs, the lugs should be crimped to the specifications given in the manufacturer's instructions for both crimp tool and lug.

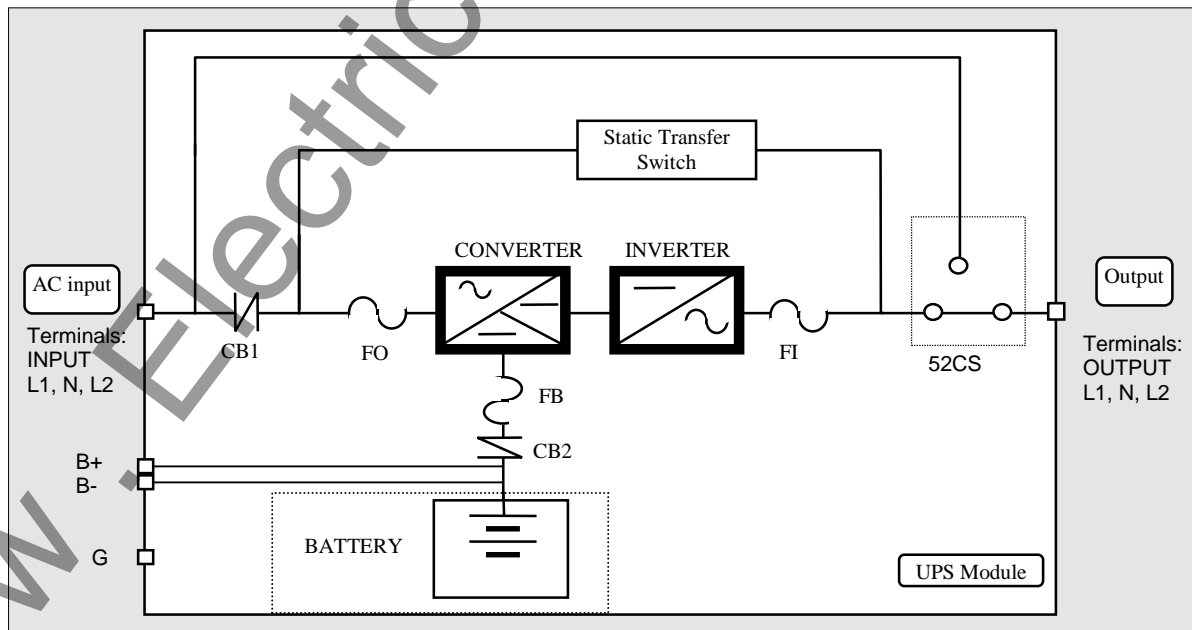
FIGURE 3.2 UPS Terminal Designation


FIGURE 3.3 Terminal Block

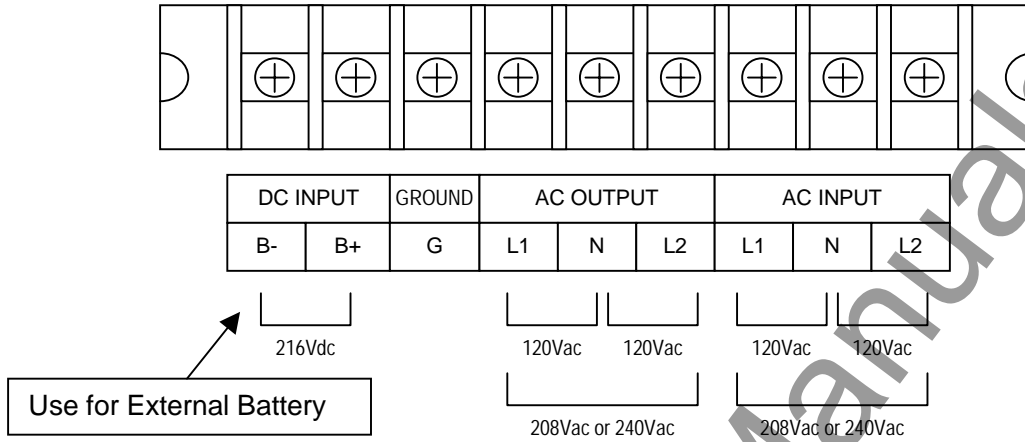


FIGURE 3.4 Field Wire Terminal Block (6kVA) (Rear View)

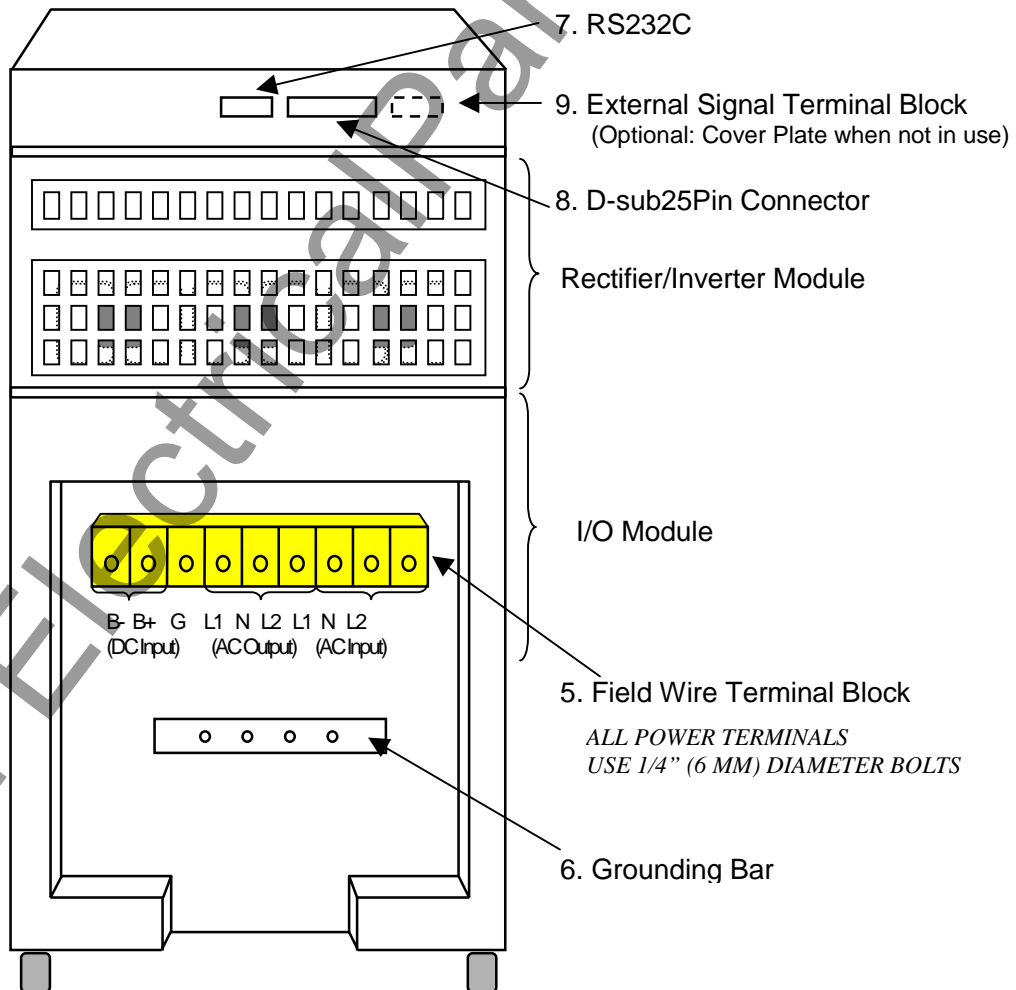


FIGURE 3.5 Field Wire Terminal Block (8,10 and 12kVA) (Rear View)

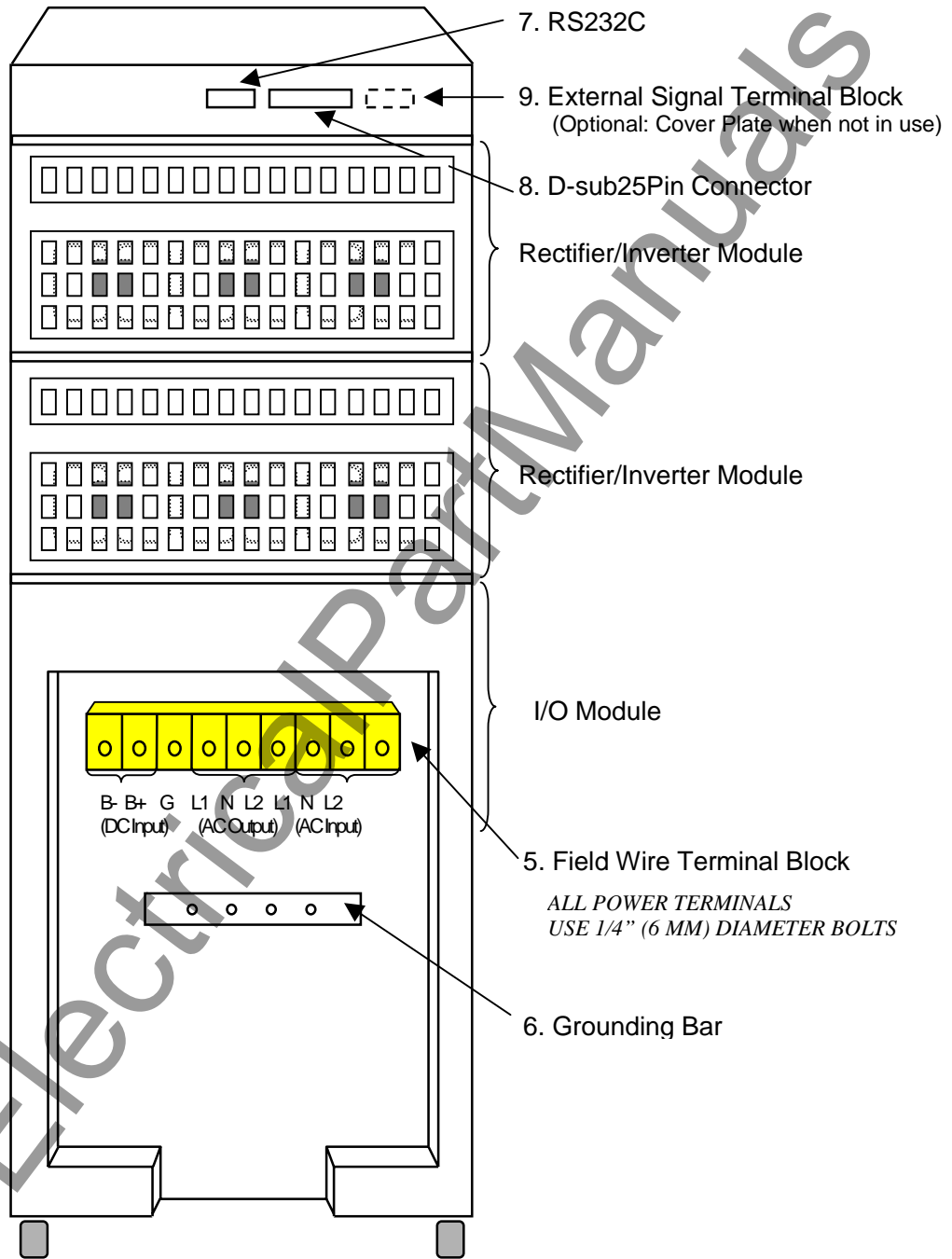


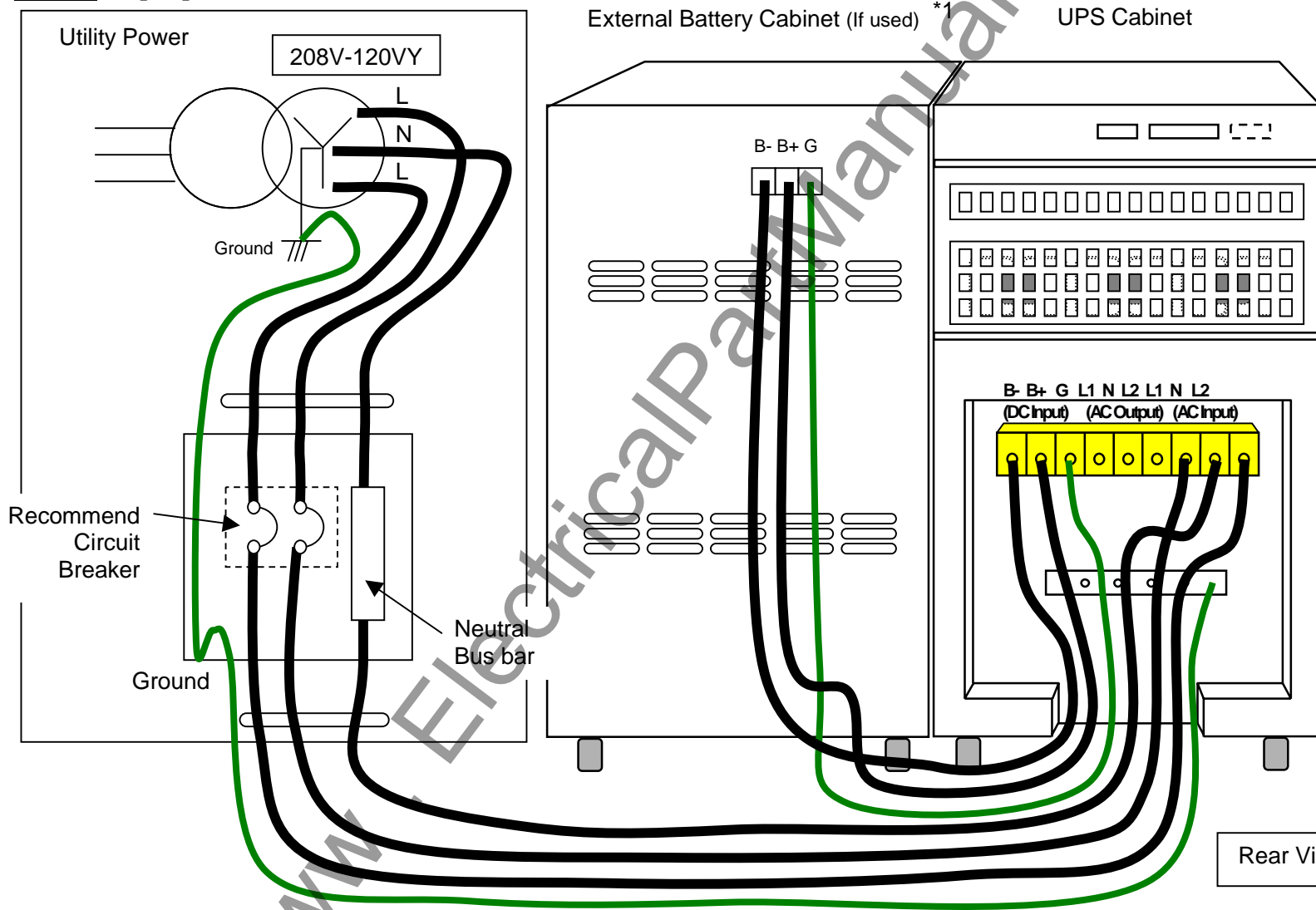


FIGURE 3.6 Field Wire Connection (208V – 120V WYE, 2 phase, 3wire)

NOTE: Proper phase rotation must be observed when connecting input wires to L1 and L2.



If code 803 occurs See next page.



*1 : Please refer to the page 3-10

Wire Connection (208V – 120V WYE, 2 phase, 3wire)

UPS Must have Clockwise Phase Rotation if Error code 803 occurs, swap L1 and L2. (see figure 3.6.1 and 3.6.2)

FIGURE 3.6.1 Correct connection

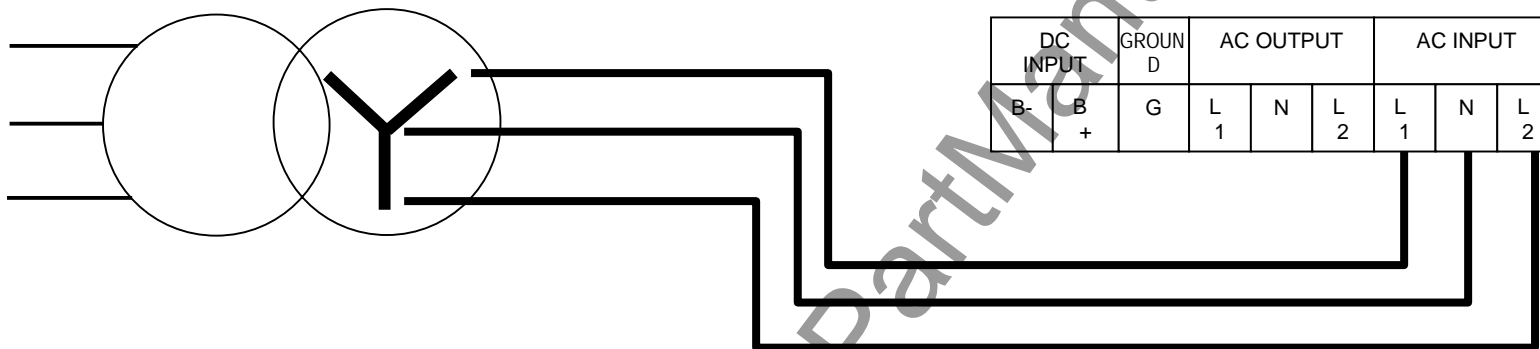


FIGURE 3.6.2 Incorrect connection

-> Code 803 Displayed on LCD when UPS powered up.

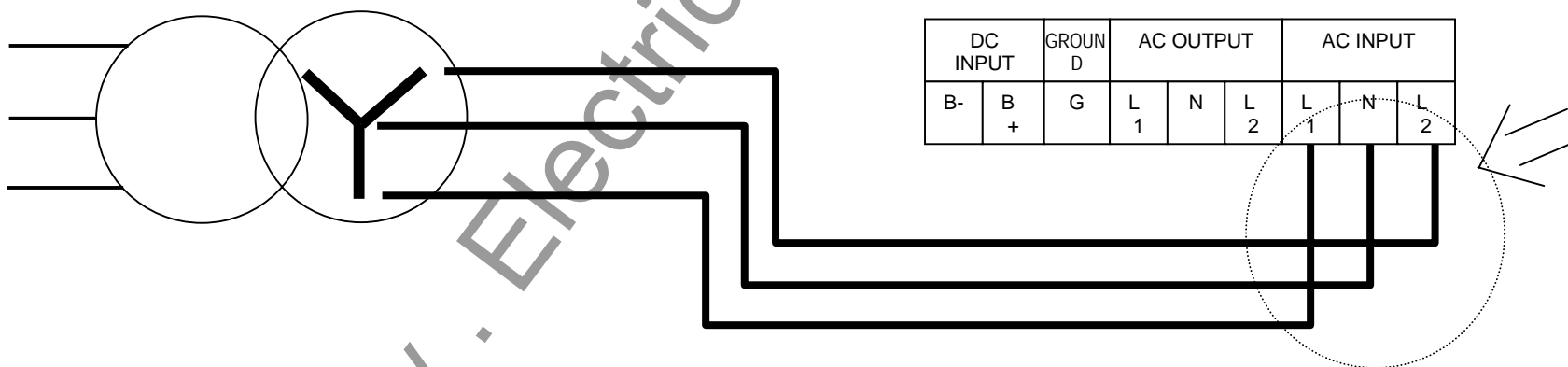
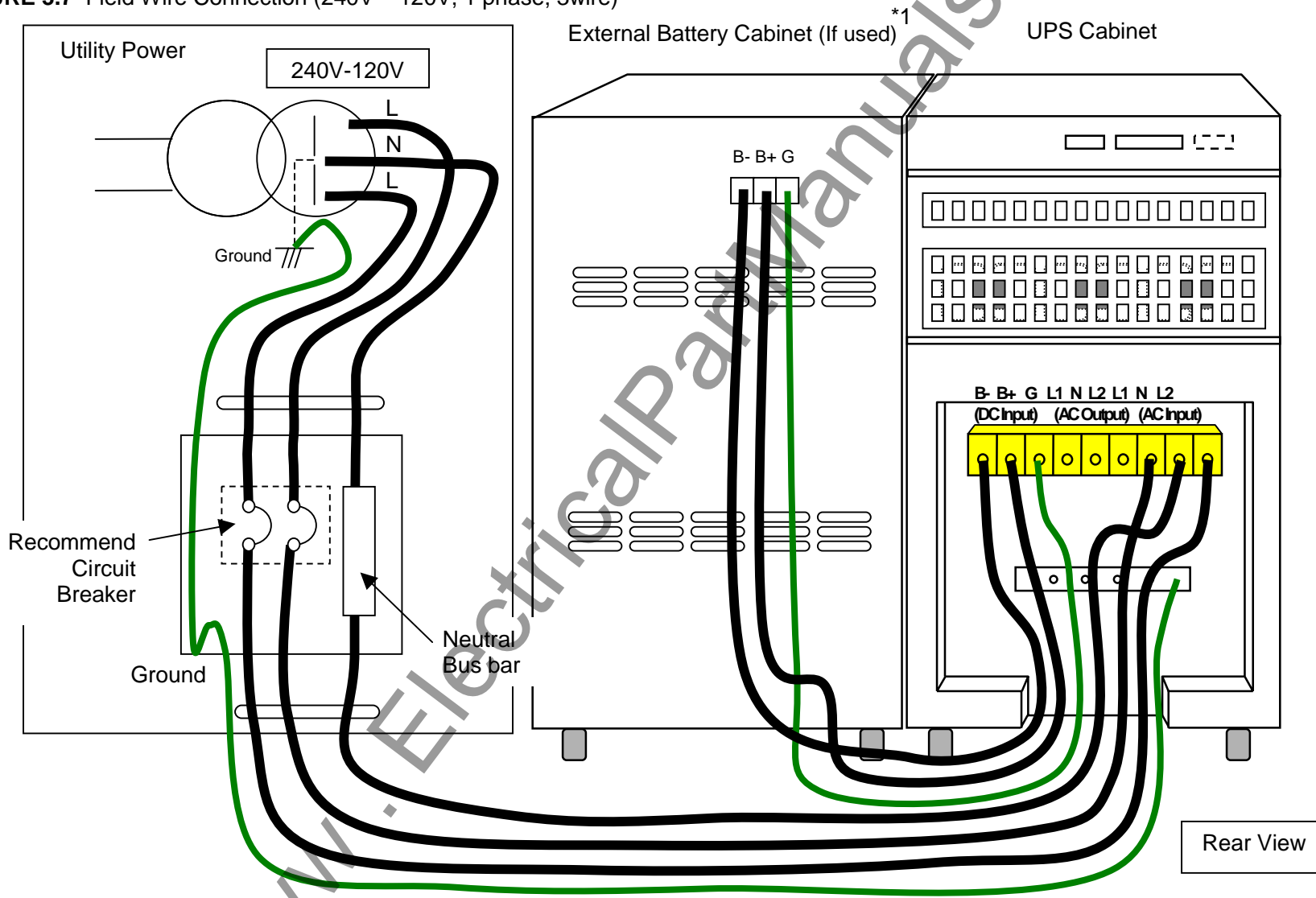


FIGURE 3.7 Field Wire Connection (240V – 120V, 1 phase, 3wire)



*1 : Please refer to the page 3-10

3.4 INSTALLATION PROCEDURE FOR BATTERY

Installation procedures of the batteries are shown on the next page.

Please refer to the following when installing and maintaining batteries:



1. Servicing of batteries should be performed or supervised by personnel knowledgeable of batteries and the required precautions. Keep unauthorized personnel away from batteries.
2. When installing or replacing batteries, install or replace with the same number and type per Table 3.4

TABLE 3.4 Type and Number of Battery

	Type	Manufacturer	Number
6kVA	HV7-12	Shin-Kobe	18
8,10 and 12kVA	HV7-12	Shin-Kobe	36



CAUTION - Do not dispose of battery or batteries in a fire. The battery may explode.

CAUTION - Do not open or mutilate the battery or batteries. Released electrolyte is harmful to the skin and eyes and may be toxic.

CAUTION - A battery can present a risk of electrical shock and high short circuit current. The following precautions should be observed when working on batteries:

- Remove watches, rings, or other metal objects.
- Use tools with insulated handles.
- Wear rubber gloves and boots.
- Do not lay tools or metal parts on top of batteries.
- Disconnect charging source prior to connecting or disconnecting battery terminals.

3.4.1 PROCEDURE FOR EXTERNAL BATTERY CONNECTION (OPTIONAL)

1. Installation procedure

Please refer to the figure 3.6 or 3.7 for connection.

Must connect external battery before internal battery is connected.

2. Set-up procedure

Please confirm the capacity "Ah (ampere hour) " of the external battery cabinet.

Refer to the Page 3-16 for the Ah (ampere hour) setup on the UPS.

3.4.2 PROCEDUR FOR INTERNAL BATTERY CONNECTION

Procedures for battery connection are as follows.

Please note, these procedures **must be performed after** the external cables are connected. For procedures for external cable connection, please refer to “3.3 PROCEDURE FOR CABLE CONNECTIONS”.

1. Remove the straps, which hold the batteries.
2. As shown in the left figure, when shipped, there are unconnected connectors for safety. Connect these unconnected connectors.

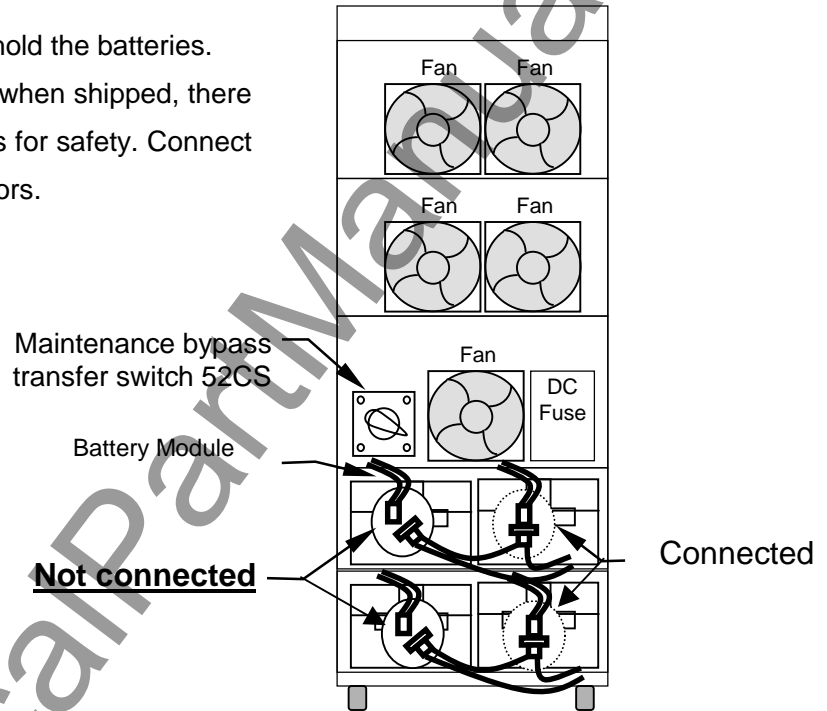


FIGURE 3.8 Battery Connection when shipped



For your safety, one side of the connectors is not connected when shipped. Connection of the battery module connectors may apply voltage to B+ / B- connectors on the Field Wire Terminal Block on the rear side of the UPS.

Please be sure to connect the external cables before connecting the battery connectors.

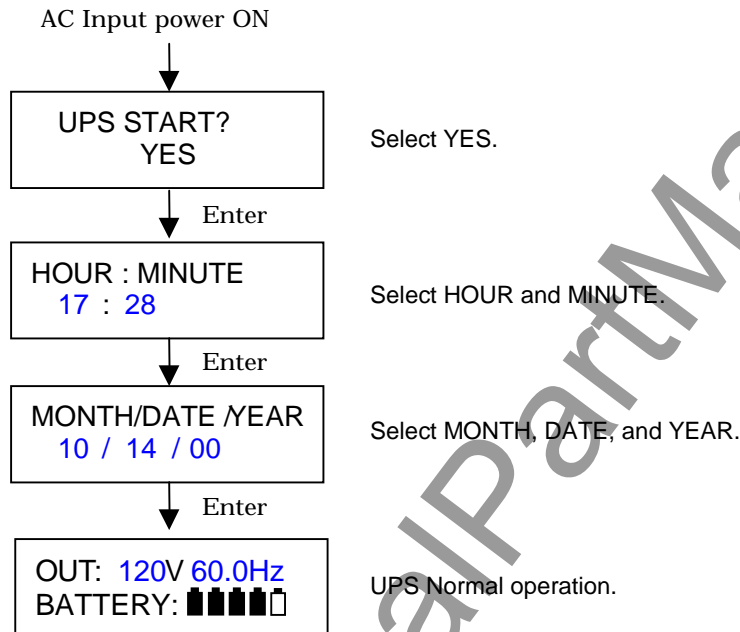
3.5 OPERATING PROCEDURES

A) UPS Initial Startup Procedure



Please be sure to confirm the internal maintenance bypass switch 52CS on “NORMAL” position before turn on AC input power.

This procedure is only performed during initial start-up.



B) UPS Start-up Procedure

1. Press and Hold “START” button for 0.5 seconds
2. The “INV.OP.” LED illuminates and the Inverter starts.

C) Bypass Operation Procedure

1. Press “MENU” button and then select “BYPASS_OP.” and press ENTER button.
2. Press “▲” or “▼” until the display shows “YES”, and then press ENTER button.
3. “BYP.OP.” LED illuminates and the UPS will be in bypass operation.



WARNING: *Verify the load is OFF if the next step is to be performed .*

NOTE: *Power to the critical load is supplied through the static bypass line.
Power to the critical load will be lost after execution of the next step.
The load will drop.*

4. If turning off all power to the critical load is desired, open the AC Input Circuit Breaker (User supplied.).



CAUTION: *In bypass mode, all UPS power terminals are still alive. Lethal voltages are present. De-energize all external sources of AC and DC power before handling UPS.*

D) UPS Shutdown Procedure

1. If a total UPS module (inverter and rectifier) shutdown is required, press the "STOP" button on the front panel.
2. Then STOP Mode window will appear on the LCD.
3. Press the "STOP" and "ENTER" buttons simultaneously.
4. The UPS will shutdown and no power is supplied to the load.



WARNING: *With this operation, although all output power from the UPS is shutdown, it is necessary to manually open the input circuit breaker (user supplied), to remove the input power to the UPS*

3.6 MAINTENANCE BYPASS SET-UP PROCEDURES (For Service Personnel Only)

A) Transfer of load from inverter to maintenance bypass

1. Press "MENU" button and then select "BYPASS_OP." and press ENTER button.
2. Press "▲" or "▼" until the display shows "YES", and then press ENTER button.
3. "BYP.OP." LED illuminates and the UPS will be in bypass operation.



WARNING: Do not transfer to Maintenance Bypass Mode unless the inverter is not running --- that is the UPS is in Static Bypass Mode.

4. After confirming that the "BYP.OP." LED is illuminated, rotate 52CS clockwise to the "TRANSFER" position (Do not rotate 52CS if the "BYP.OP." LED is NOT illuminated).
5. Then rotate 52CS clockwise to the "WAIT" position and after that push & rotate to the "BYPASS" position.
6. Transfer complete. Load is now powered from the external source.

B) Transfer of load from maintenance bypass to inverter

1. Rotate 52CS counterclockwise from the "BYPASS" position to the "WAIT" position, and wait 10 seconds until the LCD on the front panel displays the top page.



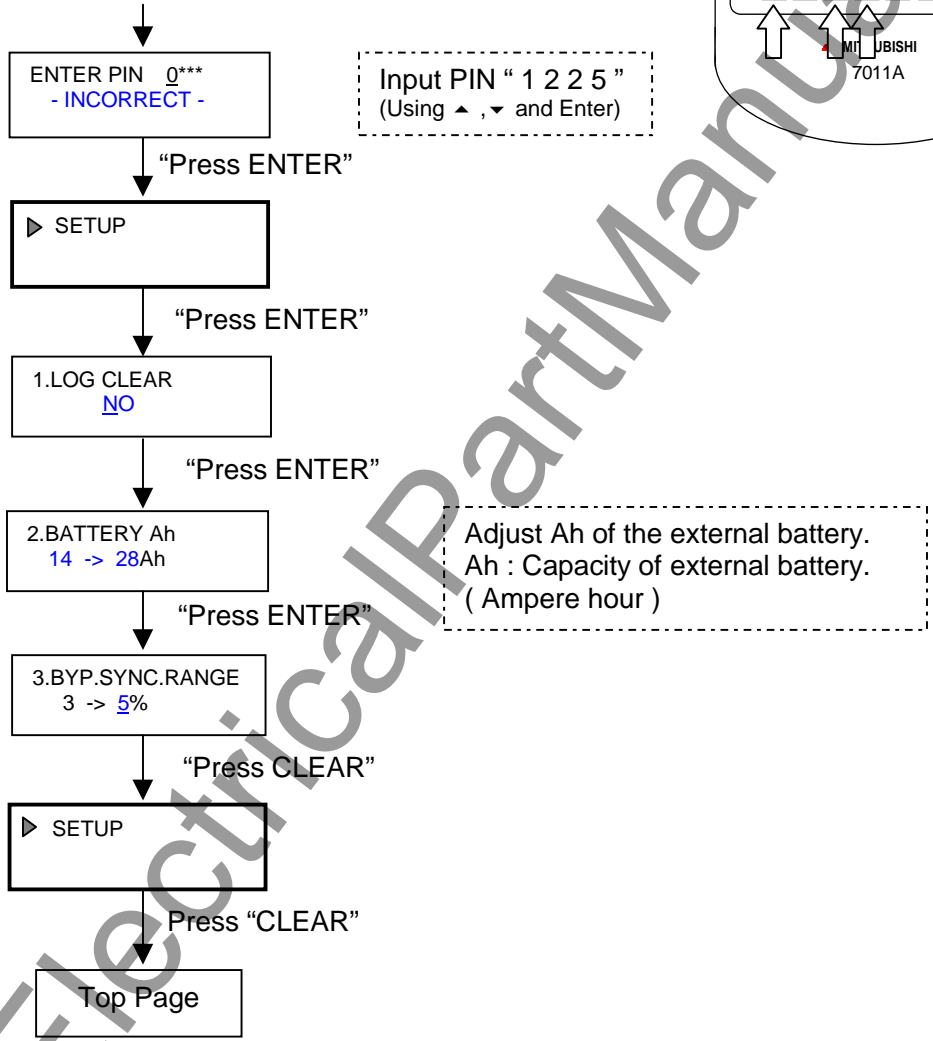
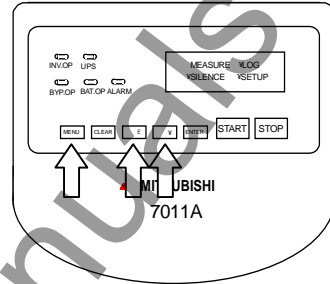
WARNING: Do not proceed to the next step until the LCD on the front panel displays the top page.

2. After confirming that the LCD on the front panel displays the top page, pull & rotate 52CS counterclockwise to the "TRANSFER" position, and then rotate to the "NORMAL" position.
3. On the UPS, press and hold the "START" button for 0.5 seconds. The "INV.OP." LED should illuminate.
4. Transfer complete. Load now powered by the inverter.

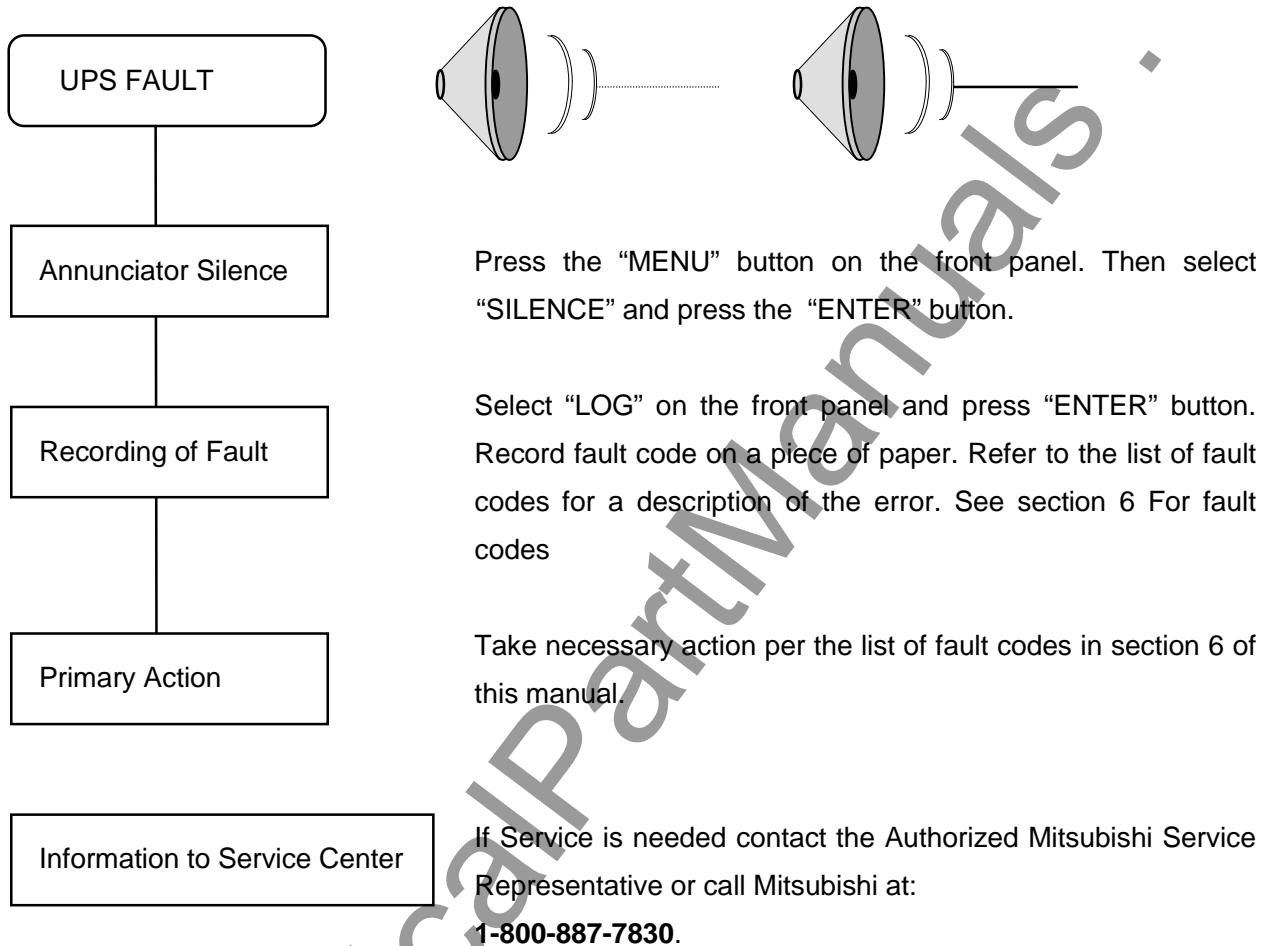
3.7 EXTERNAL BATTERY SET-UP PROCEDURES

Please confirm the capacity of the external batteries.

Press “MENU”, “▲” and “▼” buttons simultaneously for 3 seconds then Release.



4.0 RESPONSE TO UPS FAILURE



NOTE

The error code indicated on the LCD at the time of UPS alarm condition is very important. In order to minimize repair time, please include this information along with the operation status and load status, on all correspondence with Mitsubishi’s field service group.

5.0 PARTS REPLACEMENT

Contact Mitsubishi or its Authorized Service Center on all issues regarding the replacement of parts.

A) Battery

Battery lifetime may vary according to the frequency of use and the average ambient operating temperature. Battery end of life is defined as the state of charge resulting in an ampere-hour capacity less than, or equal to, 80% of nominal capacity. Replace battery if capacity is within this percentage.

B) UPS Component Parts

Contact Mitsubishi or its Authorized Service Center for a complete parts replacement schedule. Recommended replacement time interval varies with operating environment. Contact Mitsubishi or its Authorized Service Center for specific application recommendations.

6.0 FAULT CODES

This section covers the fault codes, their description and required action.

At time of error :

- A) Verify and record the occurrence of the alarm. Note fault code on the LCD.



Contact Mitsubishi Electric Automation, Inc. at 1-800-887-7830.

- B) If the External AC Input Circuit Breaker (MCCB) is in the trip state, depress the toggle to reset the breaker before re-closing.

TABLE 6.1 Failure Code List

Failure Code	Status	Guidance	Note 1 Level	Note 2 Failure LED	Note 3 Buzzer	Note 4 Event Log
003	Pre-charge abnormal	Call service engineer	Major	Lit On	[2]	[3]
061	Converter1 control abnormal	Call service engineer	Minor	Flicker	[1]	[3]
062	Converter2 control abnormal	Call service engineer	Minor	Flicker	[1]	[3]
063	Converter3 control abnormal	Call service engineer	Minor	Flicker	[1]	[3]
064	Converter4 control abnormal	Call service engineer	Minor	Flicker	[1]	[3]
102	DC overvoltage	Call service engineer	Major	Lit On	[2]	[3]
103	DC undervoltage	Call service engineer	Major	Lit On	[2]	[3]
109	DC voltage balance abnormal	Call service engineer	Major	Lit On	[2]	[3]
151	Float voltage abnormal	Call service engineer	Minor	Flicker	.	[4]
156	Battery temperture abnormal .CB2OFF.	Call service engineer	Minor	Flicker	[1]	[3]
157	Battery temperture abnormal	Check battery	Minor	Flicker	.	[4]
161	Float voltage abnormal (CB2 OFF)	Check battery	Minor	Flicker	[1]	[3]
162	Battery circuit abnormal			Flicker	.	[3]
201	Output overvoltage	Call service engineer	Major	Lit On	[2]	[3]
202	Output undervoltage	Call service engineer	Major	Lit On	[2]	[3]
218	Inverter voltage DC component increase	Call service engineer	Major	Lit On	[2]	[3]
219	Converter abnormal	Call service engineer	Major	Lit On	[2]	[3]
261	Inverter1 control abnormal	Call service engineer	Minor	Flicker	[1]	[3]
262	Inverter2 control abnormal	Call service engineer	Minor	Flicker	[1]	[3]
263	Inverter3 control abnormal	Call service engineer	Minor	Flicker	[1]	[3]
264	Inverter4 control abnormal	Call service engineer	Minor	Flicker	[1]	[3]
271	Inverter1 overcurrent	Call service engineer	Minor	Flicker	[1]	[3]
272	Inverter2 overcurrent	Call service engineer	Minor	Flicker	[1]	[3]
273	Inverter3 overcurrent	Call service engineer	Minor	Flicker	[1]	[3]
274	Inverter4 overcurrent	Call service engineer	Minor	Flicker	[1]	[3]
281	Unit1 Heat sink temperature abnormal	Call service engineer	Minor	Flicker	[1]	[3]
282	Unit2 Heat sink temperature abnormal	Call service engineer	Minor	Flicker	[1]	[3]
283	Unit3 Heat sink temperature abnormal	Call service engineer	Minor	Flicker	[1]	[3]
284	Unit4 Heat sink temperature abnormal	Call service engineer	Minor	Flicker	[1]	[3]
302	CPU. abnormal	Call service engineer	Major	Lit On	[2]	[3]
310	Control circuit abnormal	Call service engineer	Major	Lit On	[2]	[3]
403	Recurrent Automatic Transfer	Reduce load	Major	Lit On	[2]	[3]

Failure Code	Status	Guidance	Note 1 Level	Note 2 Failure LED	Note 3 Buzzer	Note 4 Event Log
454	Module temperature high	Reduce room temperature	Minor	Flicker	[1]	[4]
455	Bypass circuit abnormal	Call service engineer	Minor	Flicker	[1]	[3]
456	Bypass Overload	Reduce load	Minor	Flicker	[1]	[3]
801	Input power source abnormal 85V-144V deviation frequency 7% deviation	-	Alarm	Flicker	[1]	[4]
803	Input wire connection abnormal	Swap L1 and L2	Alarm	Lit On	[2]	[3]
806	Overload status	Check load	Alarm	Flicker	[1]	[4]
807	OverKW	Check load	Alarm	Flicker	[1]	[4]
808	Overload warning	Reduce load	Alarm	Flicker	.	
809	OverKW warning	Reduce load	Alarm	Flicker	.	
810	Instant overload	-	Alarm	.	.	[3]
812	Input voltage abnormal +/- 10. deviation or (energy conservation setting +/- 25% deviation)	-	Alarm	.	.	[4]
814	Input frequency abnormal (Due to setting)	Check input frequency	Alarm	Flicker	.	[4]
817	EPO	-	Alarm	Flicker		[3]
834	Battery depleted	-	Alarm	Flicker	.	[3]
835	Battery deplete warning	Reduce load	Alarm	Flicker	.	.
837	Unit quantity mismatch	Call service engineer	Alarm	Flicker	[1]	.

Note 1) Level

"Major" is defined as a major failure. Load transferred from inverter to the static bypass line.

"Minor" is defined as a minor failure. UPS continues to operate normally, but cause of alarm must be identified.

Note 2. Failure LED

Indicates one of two possible LED illumination patterns - continuously on (lit) or intermittent (flicker).

Note 3) Buzzer (Audible annunciator)

[1]:Intermittent Sound [2]:Continuous Sound

Note 4. Event log. In case of major failures, log 10 items after the failure.

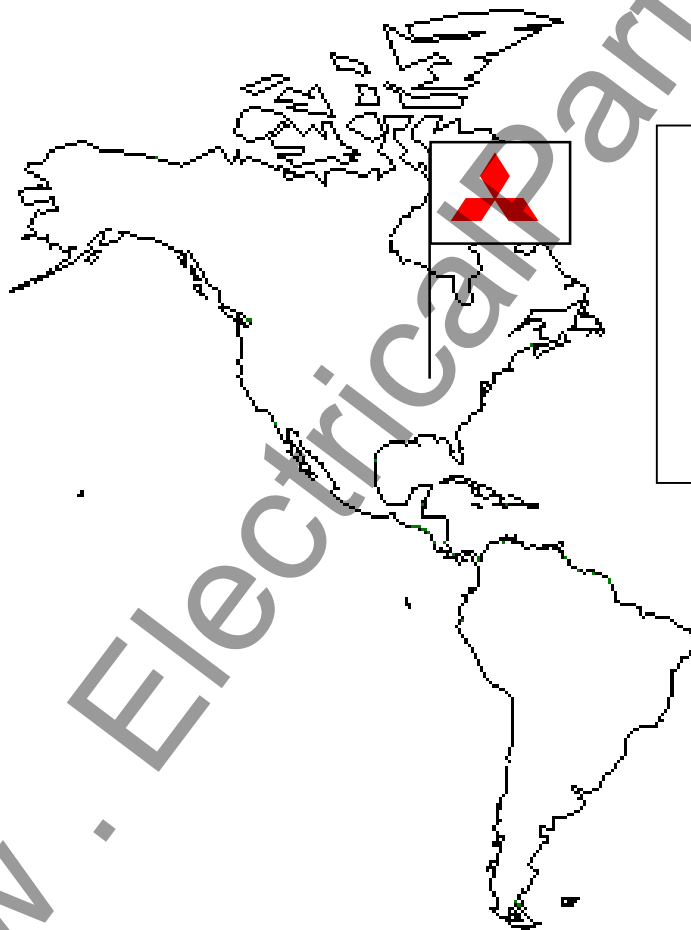
..[3]: Log time and item name at occasion. In some case, isn't logged.

..[4]: Log time and item name at occasion and clearing.

7.0 WARRANTY & OUT OF WARRANTY SERVICE

The Mitsubishi Electric UPS Systems Group Service Department has many Authorized Service Centers placed strategically throughout the US, Canada and Latin America. For both in warranty and out of warranty service, please contact Mitsubishi Electric Automation, Inc. at (847) 478-2643. To register your UPS for warranty purposes, please complete the warranty registration form and fax it to the Mitsubishi Electric UPS Systems Group, Service Department fax line shown on the registration form. (Next page)

For warranty purposes, it is essential that any and all service work that may be required on your Mitsubishi brand UPS equipment is performed by a Mitsubishi Electric Authorized Service Center. The use of non-authorized service providers may void your warranty.



Mitsubishi Electric Automation Inc,
UPS Systems Group Service Department

500 Corporate Woods Parkway,
Vernon Hills, Illinois 60061, USA
Phone: (847) 478-2643
Fax: (847) 478-2290



Mitsubishi Electric Automation, Inc.
UNINTERRUPTIBLE POWER SUPPLIES
500 Corporate Woods Parkway, Vernon Hills, IL 60061
Phone: (847) 478-2643, Fax: (847) 478-2290

UPS Warranty Registration

 Register UPS for Warranty

 Address Change

To validate the Warranty on your UPS this form must be filled out completely by Customer and returned.

CUSTOMER INFORMATION			
Your Name:		Job Title:	
Company Name:			
Division / Department:			
Address:			
City:		State:	Zip Code:
Country:		Province:	
Business Phone:		Ext:	Fax:
E-Mail: _____ @ _____		Internet Address:	
UPS Model #:		Capacity (kVA):	UPS Serial #:
Start-Up Date: / /		Authorized Mitsubishi Service Company (if known):	
Signature: _____			Date: / /

Which **ONE** of These Best Describes Your Organization's Primary Business Classification?

{Energy Producer}

- Utility
 Alternate Energy

{Manufacturing Co.}

- OEM
 Process
 Consumer Goods
 Electronics
 Power Quality Equipment

Commercial Business

- Electrical Contractor
 Healthcare
 Internet
 Education/Univ. Service

{Service}

- Consulting
 Engineering
 Outsourcing
 Financial/Legal/Insurance

{Government}

- Military
 Municipals
 Federal/State/Local

Communications

- Distributors/Reps
 Other _____

Number of Employees at This Location is:

- 1 - 19 100 - 249 1000 or more
 20 - 49 250 - 499
 50 - 99 500 - 999

Overall how was Start-Up performed:

- Unsatisfactory Satisfactory Exceeded Expectations

Would you like to receive future product updates and news?

- Yes No

**After Start-Up has been done Fax completed Form to:
(847) 478-2290**