

Model # 300 DFCEB / SERIAL # J930522806

591 Gallon Fuel Tank



Operator's Manual

Joe Webber
1-412-781-8000

DFBC DFBF
DFBD DFCEB
DFBE DFCC
GENERATOR SETS

Heat Element

333-0935 320.79

373 0466

Heat Element

309.87

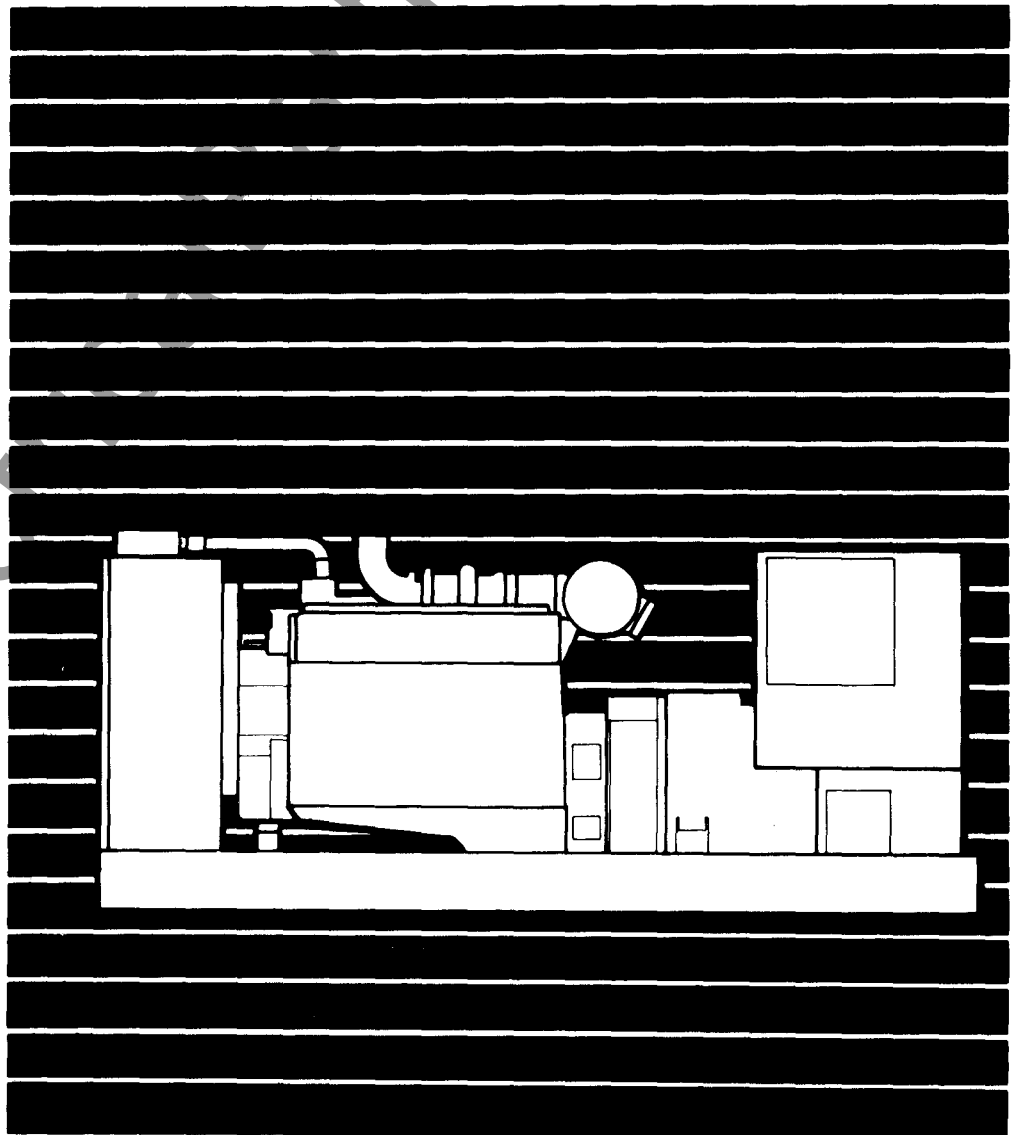

Safety Precautions

Before operating the generator set, read the Operator's Manual and become familiar with it and the equipment. **Safe and efficient operation can be achieved only if the equipment is properly operated and maintained.** Many accidents are caused by failure to follow fundamental rules and precautions.

The following symbols, found throughout this manual, alert you to potentially dangerous conditions to the operator, service personnel, or the equipment.

⚠ DANGER *This symbol warns of immediate hazards which will result in severe personal injury or death.*

⚠ WARNING *This symbol refers to a hazard or unsafe practice which can result in severe personal injury or death.*

⚠ CAUTION *This symbol refers to a hazard or unsafe practice which can result in personal injury or product or property damage.*

FUEL AND FUMES ARE FLAMMABLE. Fire and explosion can result from improper practices.

- DO NOT fill fuel tanks while engine is running, unless tanks are outside the engine compartment. Fuel contact with hot engine or exhaust is a potential fire hazard.
- DO NOT permit any flame, cigarette, pilot light, spark, or other ignition source near the generator set or fuel tank.
- Fuel lines must be adequately secured and free of leaks. Fuel connection at the engine should be made with an approved flexible line. Do not use copper piping on flexible lines as copper will become brittle if continuously vibrated or repeatedly bent.
- Be sure all fuel supplies have a positive shutoff valve.
- Do not smoke while servicing lead acid batteries. Lead acid batteries emit a highly explosive hydrogen gas that can be ignited by electrical arcing or by smoking.

EXHAUST GASES ARE DEADLY

- Provide an adequate exhaust system to properly expel discharged gases. Visually and audibly inspect the exhaust daily for leaks per the maintenance schedule. Ensure that exhaust manifolds are secured and not warped. Do not use exhaust gases to heat a compartment.
- Be sure the unit is well ventilated.

MOVING PARTS CAN CAUSE SEVERE PERSONAL INJURY OR DEATH

- Keep your hands, clothing, and jewelry away from moving parts.
- Before starting work on the generator set, disconnect starting batteries, negative (-) cable first. This will prevent accidental starting.
- Make sure that fasteners on the generator set are secure. Tighten supports and clamps, keep guards in position over fans, drive belts, etc.

- Do not wear loose clothing or jewelry in the vicinity of moving parts, or while working on electrical equipment. Loose clothing and jewelry can become caught in moving parts. Jewelry can short out electrical contacts and cause shock or burning.
- If adjustment must be made while the unit is running, use extreme caution around hot manifolds, moving parts, etc.

ELECTRICAL SHOCK CAN CAUSE SEVERE PERSONAL INJURY OR DEATH

- Remove electric power before removing protective shields or touching electrical equipment. Use rubber insulative mats placed on dry wood platforms over floors that are metal or concrete when around electrical equipment. Do not wear damp clothing (particularly wet shoes) or allow skin surface to be damp when handling electrical equipment.
- Use extreme caution when working on electrical components. High voltages can cause injury or death. DO NOT tamper with interlocks.
- Follow all applicable state and local electrical codes. Have all electrical installations performed by a qualified licensed electrician. Tag open switches to avoid accidental closure.
- DO NOT CONNECT GENERATOR SET DIRECTLY TO ANY BUILDING ELECTRICAL SYSTEM. Hazardous voltages can flow from the generator set into the utility line. This creates a potential for electrocution or property damage. Connect only through an approved isolation switch or an approved paralleling device.

GENERAL SAFETY PRECAUTIONS

- Coolants under pressure have a higher boiling point than water. DO NOT open a radiator or heat exchanger pressure cap while the engine is running. Allow the generator set to cool and bleed the system pressure first.
- Benzene and lead, found in some gasoline, have been identified by some state and federal agencies as causing cancer or reproductive toxicity. When checking, draining or adding gasoline, take care not to ingest, breathe the fumes, or contact gasoline.
- Used engine oils have been identified by some state or federal agencies as causing cancer or reproductive toxicity. When checking or changing engine oil, take care not to ingest, breathe the fumes, or contact used oil.
- Provide appropriate fire extinguishers and install them in convenient locations. Consult the local fire department for the correct type of extinguisher to use. Do not use foam on electrical fires. Use extinguishers rated ABC by NFPA.
- Make sure that rags are not left on or near the engine.
- Remove all unnecessary grease and oil from the unit. Accumulated grease and oil can cause overheating and engine damage which present a potential fire hazard.
- Keep the generator set and the surrounding area clean and free from obstructions. Remove any debris from the set and keep the floor clean and dry.
- Do not work on this equipment when mentally or physically fatigued, or after consuming any alcohol or drug that makes the operation of equipment unsafe.

Table of Contents

TITLE	PAGE
SAFETY PRECAUTIONS	Inside Front Cover
INTRODUCTION	1-1
About this Manual	1-1
How to Obtain Service	1-1
SPECIFICATIONS	2-1
OPERATION	3-1
General	3-1
Prestart Checks	3-1
Control Panel	3-1
Control Panel Interior	3-3
Starting	3-4
Stopping	3-5
Break-in	3-5
No-Load Operation	3-5
Exercise Period	3-5
High/Low Operating Temperatures	3-5
Power Rating Factors	3-5
TROUBLESHOOTING	4-1
MAINTENANCE	5-1
Generator Set Inspection	5-2
Lubrication System	5-2
Crankcase Breathers	5-5
Coolant System	5-5
Fuel System	5-9
Air Cleaner	5-10
Batteries	5-11
ADJUSTMENTS	6-1
Electric Governor	6-1

www.ElectricalPartManuals.com

Section 1. Introduction

ABOUT THIS MANUAL

This manual provides general information for operating and maintaining your generator set. Study this manual carefully and observe all warnings and cautions. Using the generator set properly and following a regular maintenance schedule will contribute to longer unit life, better performance, and safer operation.

Included with the generator set literature package is a copy of the Cummins Manual for the engine. In case of conflicting information, the Generator Set Operator's Manual takes precedence over the engine manual.

HOW TO OBTAIN SERVICE

When the generator set requires servicing, contact your Distributor for assistance. Factory trained Parts and Service representatives are ready to handle all your service needs.

When contacting your Distributor, always supply the complete Model number and Serial number as shown on the nameplate. The nameplate is located on the side of the generator control box.

▲WARNING

INCORRECT SERVICE OR REPLACEMENT OF PARTS CAN RESULT IN SEVERE PERSONAL INJURY, DEATH AND/OR EQUIPMENT DAMAGE. SERVICE PERSONNEL MUST BE QUALIFIED TO PERFORM ELECTRICAL AND MECHANICAL SERVICE.

www.ElectricalPartManuals.com

Section 2. Specifications

MODEL NUMBER	200 DFBC 200 NT4	230 DFBD 230 NT4	250 DFBE 250 NT5	275 DFBF 275 NT6	300 DFCE 300 NTA2	350 DFCC 350 NTA3
Engine Cummins Diesel Series	NT855-G4	NT855-G4	NT855-G5	NT855-G6	NTA855-G2	NTA855-G3
Generator 3 Phase, 60 Hz (kVA @ 0.8 PF) 3 Phase, 50 Hz (kVA @ 0.8 PF)	200 kW (250.0) 175 kW (218.8)	230 kW (287.5) 200 kW (250.0)	250 kW (312.5) 220 kW (275.0)	275 kW (343.8) 250 kW (312.5)	300 kW (375.0) 275 kW (343.8)	350 kW (437.5) 310 kW (387.5)
Electrical System Starting Voltage	24 Volts DC	24 Volts DC	24 Volts DC	24 Volts DC	24 Volts DC	24 Volts DC
Battery	Two, 12-Volt	Two, 12-Volt	Two, 12-Volt	Two, 12-Volt	Two, 12-Volt	Two, 12-Volt
Cooling System Capacity (Std. Radiator)	16.5 Gallons (62 L)	16.5 Gallons (62 L)	16.5 Gallons (62 L)	16.5 Gallons (62 L)	17 Gallons (64 L)	17 Gallons (64 L)
Lubricating System Oil Capacity with Filters	42 Quarts	42 Quarts	42 Quarts	42 Quarts	42 Quarts	42 Quarts
Oil Type -13°F to 95°F (-25°C to 35°C) -14°F (-10°C) and above 32°F (0°C) and above	SAE 10W-30 SAE 15W-40 SAE 20W-40	SAE 10W-30 SAE 15W-40 SAE 20W-40	SAE 10W-30 SAE 15W-40 SAE 20W-40	SAE 10W-30 SAE 15W-40 SAE 20W-40	SAE10W-30 SAE 15W-40 SAE 20W-40	SAE 10W-30 SAE 15W-40 SAE 20W-40

www.ElectricalPartManuals.com

Section 3. Operation

GENERAL

This section covers prestart checks, starting and stopping and operating the generator set. Each operator should read through this entire section before attempting to start the set. It is essential that the operator be completely familiar with the set for safe operation.

PRESTART CHECKS

Before starting, be sure the following checks have been made and the unit is ready for operation. Refer to the *Maintenance* section for the recommended procedures.

Lubrication

Check the engine oil level. Keep the oil level near as possible to the dipstick high mark without overfilling.

Coolant

Check the engine coolant level. The coolant should be about two inches below the radiator cap opening. Do not check while the engine is hot.

▲WARNING

Contact with hot coolant can result in serious burns. Do not bleed hot, pressurized coolant from a closed cooling system.

Fuel

Make sure the fuel tanks have sufficient fuel and fuel system is primed. See the *Maintenance* section for recommended fuel.

CONTROL PANEL

The following describes the function and operation of the standard Detector 7 and optional Detector 12 generator set control. All instruments and control switches are located on the face of the control panel as illustrated in Figure 3-1. The control panel is separated into a DC panel for monitoring the engine and an AC panel for monitoring the generator.

▲WARNING

EXHAUST GAS IS DEADLY!

Exhaust gases contain carbon monoxide, an odorless and colorless gas. Carbon monoxide is poisonous and can cause unconsciousness and death. Symptoms of carbon monoxide poisoning can include:

- **Dizziness**
- **Nausea**
- **Headache**
- **Weakness and Sleepiness**
- **Throbbing in Temples**
- **Muscular Twitching**
- **Vomiting**
- **Inability to Think Coherently**

IF YOU OR ANYONE ELSE EXPERIENCE ANY OF THESE SYMPTOMS, GET OUT INTO THE FRESH AIR IMMEDIATELY. If symptoms persist, seek medical attention. Shut down the unit and do not operate until it has been inspected and repaired.

Protection against carbon monoxide inhalation includes proper installation and regular, frequent visual and audible inspections of the complete exhaust system.

1-P/EM

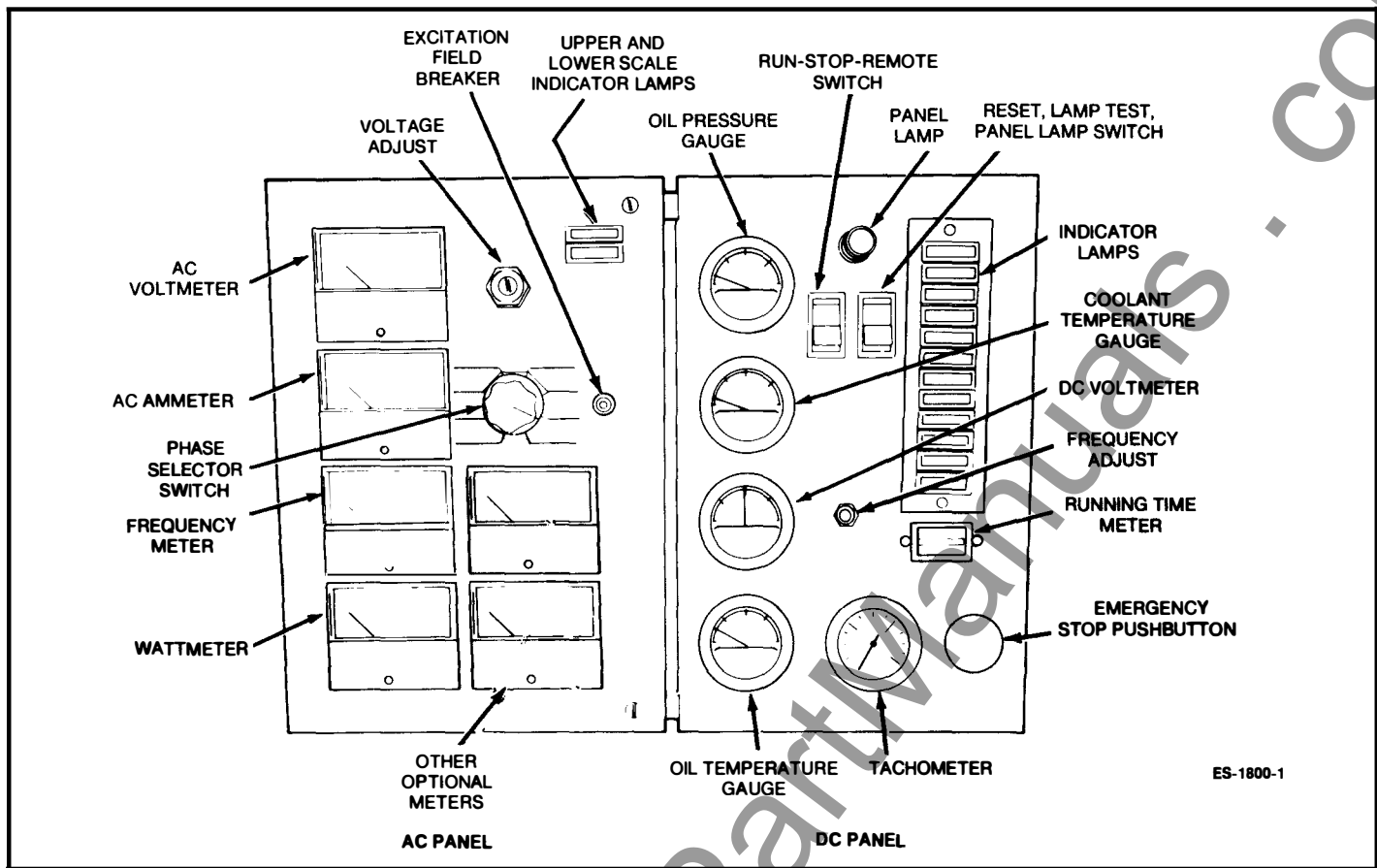

FIGURE 3-1. CONTROLS (Detector-12 and AC Meter Options Shown)

DC Panel

Panel Lamp: Illuminates control panel.

Oil Pressure Gauge: Indicates pressure of lubricating oil in engine (wired to a sensor unit located on the engine).

Coolant Temperature Gauge: Indicates temperature of circulating coolant in engine (wired to a sensor unit located on the engine).

DC Voltmeter: Indicates the battery charging system voltage.

Run/Stop/Remote Switch: Starts and stops the unit locally, or from a remote location wired to the control engine monitor board.

Running Time Meter: Registers the total number of hours the unit has run. Use it to keep a record of periodic servicing. Time is cumulative; meter cannot be reset.

Reset/Lamp Test/Panel Lamp Switch: Resets the fault circuit only when the Run/Stop/Remote switch is in the Stop (Reset) position. Tests fault lamps and turns on the control panel lamp.

Tachometer (Optional): Provides constant monitoring of engine r/min.

Speed Adjusting Rheostat (Optional): Used in conjunction with an optional electronic governor to adjust engine speed.

Oil Temperature Gauge (Optional): Indicates temperature of lubricating oil in engine (wired to a sensor unit located on the engine).

Emergency Stop Button (Optional): Push-in switch for emergency shutdown of the engine.

Detector 7-Indicator Lamps: The standard control panel has seven indicator lamps which are described as follows:

- RUN (green) lamp comes on when both starter circuits are opened after unit starting.
- PRE LO OIL PRES (yellow) indicates engine oil pressure is marginally low.
- PRE HI ENG TEMP (yellow) indicates engine temperature is marginally high.
- LO OIL PRES (red) indicates engine has shut down because of critically low oil pressure.
- HI ENG TEMP (red) indicates engine has shut down because of critically high temperature.
- OVERSPEED (red) indicates engine has shut down because of excessive speed.
- OVERCRANK (red) indicates engine has shut down because of a failure to start during the cranking period.

Detector 12-Indicator Lamps: The optional twelve-lamp control version includes all features of the seven-lamp version plus the following:

- **FAULT 1 (red)** an undedicated fault. May be factory programmed as a shutdown or non-shutdown, and as a timed or non-timed fault. (Normally set for timed shutdown).
- **FAULT 2 (red)** Same features as Fault 1 (Normally set for timed shutdown).
- **LOW ENG TEMP (yellow)** engine temperature is marginally low for starting. Indicates inoperative coolant heater.
- **LO FUEL (yellow)** indicates fuel supply is marginally low.
- **SWITCH OFF (flashing red)** indicates generator set is not in automatic start operation mode.

CAUTION *Yellow lamps indicate potential problems that could damage the genset. Refer to Troubleshooting, Table 4-1.*

AC Panel

AC Voltmeter (Optional): Dual range instrument indicating AC voltage. Measurement range in use shown on indicator light.

AC Ammeter (Optional): Dual range instrument indicates AC generator line current.

Wattmeter (Optional): Continuously gives reading of the generator output in kilowatts.

Power Factor Meter (Optional): Indicates percent power factor of AC output.

Frequency Meter (Optional): Indicates generator output frequency in hertz. It can be used to check engine speed (each hertz equals 30 r/min).

Voltage Adjusting Rheostat (Optional): Provides approximately plus or minus five percent adjustment of the rated output voltage.

Upper and Lower Scale Indicator Lamps (Optional): Indicates which scale to use on the AC voltmeter and ammeter.

Phase Selector Switch (Optional): Selects phases of generator output to be measured by AC voltmeter and AC ammeter.

Engine Pyrometers (Optional): Indicate engine exhaust and inlet air temperatures.

Field Breaker: Provides generator exciter and regulator protection from overheating in the event of certain failure modes of generator, exciter and voltage regulator.

CONTROL PANEL INTERIOR

Generator AC Voltage Regulator

The solid-state regulator controls AC output voltage from the generator at a predetermined level regardless of load.

Engine Control Module

Electronic and relay components of the engine monitoring circuit are on a circuit board assembly. Sensor inputs are connected by the wiring harness to plug connectors on the board. The control module shuts down the engine under any of the following conditions.

- **Overcrank** - Limits engine cranking to 75 seconds. If engine fails to start, the module lights a fault lamp and opens the cranking circuit. The cycle cranking option allows three 15-second cranking cycles with two 15-second rest periods on the 12-lamp control.
- **Overspeed** - Shuts down the engine immediately if overspeed occurs and lights a fault lamp. It is factory adjusted to shut down 60 hertz units at 2100 ± 90 r/min, 50 hertz units at 1850 ± 90 r/min.
- **Low Oil Pressure** - Shuts down the engine immediately if oil pressure drops below 14 psi (97 kPa) and lights a fault lamp. The fault is time-delayed about 10 seconds following starter disconnect and inhibited during cranking. The delay allows oil pressure to rise to normal before the electronic control module monitors this system.

A pre-low oil pressure sensor and lamp provides an alarm that oil pressure is marginally low, 20 psi (137 kPa) or less. The cause should be found and corrected as soon as possible.

- **High Engine Temperature** - shuts down the engine immediately if coolant temperature rises above 222°F (106°C) and lights a fault lamp. The fault is time-delayed about 10 seconds following starter disconnect and inhibited during cranking. This delay allows coolant in a hot engine time to circulate and return the water jacket to normal before the electronic control module monitors this system.

A pre-high engine temperature sensor and lamp provides an alarm that engine temperature is marginally high, 215°F (102°C). The cause should be found and corrected as soon as possible.

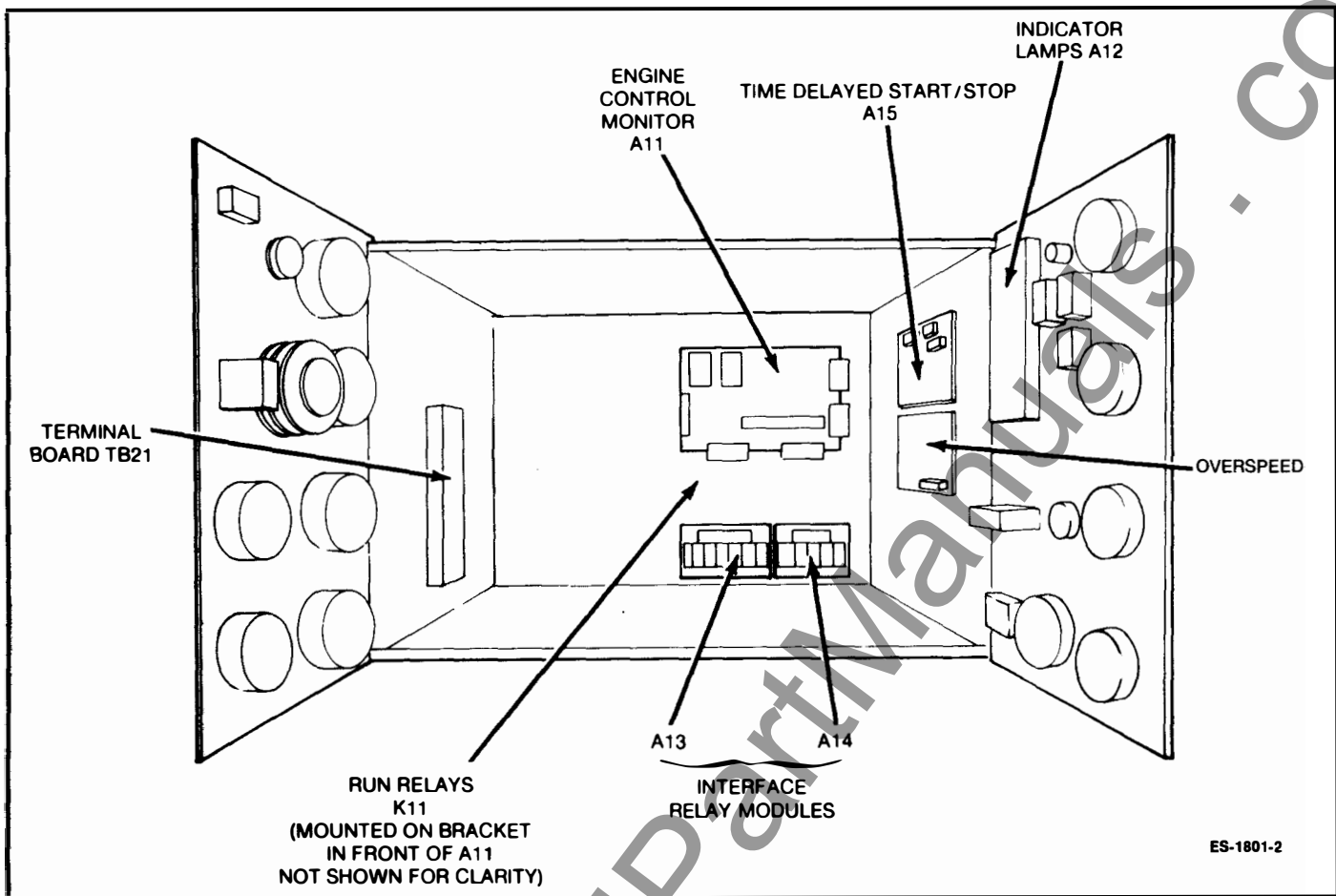

FIGURE 3-2. CONTROL PANEL INTERIOR

CAUTION *The high engine temperature shutdown system will not operate if the coolant level is too low. The high engine temperature sensor monitors coolant temperature. Loss of coolant will prevent sensor operation and allow the engine to overheat causing severe damage to the engine. Therefore, maintain adequate coolant level for proper operation of the high engine temperature shutdown system.*

- Low Coolant Level Shutdown (Optional) - A submerged sensor in the top portion of the radiator shuts down the engine and lights the Hi Engine Temp fault lamp when the coolant level falls below the level of the sensor.

STARTING

The following sections cover the three systems used to start the generator set.

Starting at Control Panel

Move the Run/Stop/Remote switch on the DC panel (Figure 3-1) to the RUN position. This will activate the engine control system and the starting system. The starter will begin cranking and after a few seconds the engine should start. The starter will disconnect when the engine reaches a speed of 450 to 570 r/min.

If the engine does not start, the starter will disengage after a specified period of time and the control will indicate an overcrank fault. Generator sets with the standard overcrank control will crank continuously for up to 75 seconds before disengaging the starter. Generator sets with the cycle cranking option will crank for 15 seconds and then stop for 15 seconds until 3 cycles have been completed. To clear an overcrank fault, place the Run/Stop/Remote switch in the STOP position and momentarily depress the Reset switch. Wait two minutes for the starter motor to cool and then repeat the starting procedure. If the engine does not run after a second attempt at starting, refer to the Troubleshooting section.

Starting From Remote Location

Move the Run/Stop/Remote switch on the generator set DC panel to the REMOTE position. This allows the generator set to be started from a remote switch. Closing the remote switch initiates the starting sequence described in the previous section.

Automatic Starting

Place the Run/Stop/Remote switch on the generator set DC panel in the REMOTE position if an automatic transfer switch is used. This allows the transfer switch to start the generator set if a power outage occurs and stop it when the power returns.

STOPPING

Before Stopping

Run the generator set at no load for three to five minutes before stopping. This allows the lubricating oil and engine coolant to carry heat away from the combustion chamber and bearings.

To Stop

If the set was started at the set control panel or at a remote control panel, move the Run/Stop/Remote switch or remote starting switch to the STOP position. If the set was started by an automatic transfer switch, the set will automatically stop about 15 minutes after the normal power source returns.

BREAK-IN

Drain and replace the crankcase oil after the first 50 hours of operation on new generator sets. Refer to the MAINTENANCE section of this manual for the recommended procedures.

NO-LOAD OPERATION

Periods of no load operation should be held to a minimum. If it is necessary to keep the engine running for long periods of time when no electric output is required, best engine performance will be obtained by connecting a "dummy" electrical load. Such a load could consist of heater element, etc.

EXERCISE PERIOD

Generator sets on continuous standby must be able to go from a cold start to being fully operational in a matter of seconds. This can impose a severe burden on engine parts.

Regular exercising keeps engine parts lubricated, prevents oxidation of electrical contacts and in general helps provide reliable engine starting. Exercise the generator set at least once a week for a minimum of 30 minutes with load so the engine reaches normal operating temperatures.

Automatic transfer switches have as an option an exerciser that can be preset to provide regular exercise periods. Typically the exerciser can be set for time of start, length of run, and day of week.

HIGH/LOW OPERATING TEMPERATURES

Use a coolant heater if a separate source of power is available. The optional heater will help provide reliable starting under adverse weather conditions. Be sure the voltage of the separate power source is correct for the heater element rating.

CAUTION *To avoid damage to heater, be sure the cooling system is full before applying power to the heater.*

POWER RATING FACTORS

The generator set power rating applies to sets used in standby applications. The set will operate at the stated rating for the duration of normal utility power interruptions. The rating was established for a standard radiator cooled set running on diesel fuel and operating at an altitude of 300 feet (92 m) with an ambient temperature of 81°F (27°C). For a rating relative to other applications, altitudes, cooling systems, or ambient temperatures, contact your authorized distributor.

www.ElectricalPartManuals.com

Section 4. Troubleshooting

The generator set has a number of sensor units that continuously monitor the engine for abnormal conditions such as low oil pressure or high coolant temperature. If an abnormal condition does occur, the engine monitor will activate a fault lamp and may also stop the engine depending on the condition. If the generator set does shut down, the operator may be able to restart the set after making certain adjustments or corrections. This section describes the operation of the fault condition system and suggested troubleshooting (Table 4-1) procedures for the operator.

The standard seven light control has a single green light to indicate RUN, two amber pre-fault lights and four red fault lights. The optional twelve light control has a single green light to indicate RUN, four amber lights and seven red fault lights. Both controls also have a terminal connection for an audible alarm which will sound when a fault occurs.

Safety Considerations

High voltages are present within the control box and generator output box when the generator is running. Do not open the control box or generator output box while set is running.

▲WARNING *Contacting high voltage components can cause serious personal injury or death. Keep control and output box covers in place during troubleshooting.*

Generator set installations are normally designed for automatic starting or remote starting. When troubleshooting a set that is shut down, make certain the

generator set cannot be accidentally restarted. Place the Run/Stop/Remote switch in the STOP position and remove the negative battery cable from the set starting battery.

▲WARNING *Accidental starting of the generator set during troubleshooting can cause severe personal injury or death. Disable the generator set before troubleshooting.*

When a fault comes on during operation, follow the procedures in Table 4-1 to locate and correct the problem. For any symptom not listed, contact your distributor for service.

Resetting the Control

The external alarm and fault lamp can be deactivated by placing the Run/Stop/Remote switch in the Stop position and pressing the Reset/Lamp Test switch. Locate the problem and make the necessary corrections before restarting the generator set. While pressing the Reset/Lamp Test switch, observe that all lamps light.

Line Circuit Breaker (Optional)

The optional line circuit breaker mounts on the generator output box. If the load exceeds the generator current rating, the line circuit breaker will open to prevent the generator from being overloaded. If the circuit breaker trips, locate the source of the overload and correct as required. Manually reset the breaker to reconnect the load to the generator.

TABLE 4-1. TROUBLESHOOTING



Many troubleshooting procedures present hazards which can result in severe personal injury or death. Only qualified service personnel with knowledge of fuels, electricity, and machinery hazards should perform service procedures. Review safety precautions on inside cover page.

SYMPTOM	CORRECTIVE ACTION
1. Green RUN lamp lights following engine start-up.	1. Indicates all engine systems are normal. No corrective action required.
2. PRE HI ENGINE TEMP lamp lights. Engine continues to operate.	2. Indicates engine has begun to overheat and engine temperature has risen to approximately 215°F (102°C). If generator is powering non-critical and critical loads and cannot be shut down, use the following: a. Reduce load if possible by turning off non-critical loads. b. Check air inlets and outlets and remove any obstructions to airflow. c. Open doors or windows in generator area to increase ventilation. If engine can be stopped, follow procedure in step 3.
3. HI ENG TEMP lamp lights. Engine shuts down.	3. Indicates engine has overheated (engine temperature has risen above 222°F/106°C) or coolant level is low (sets with coolant level sensor). Allow engine to cool down completely before proceeding with the following checks: a. Check coolant level and replenish if low. Look for possible coolant leakage points and repair if necessary. b. Check for obstructions to cooling airflow and correct as necessary. c. Check for a slipping fan belt and tighten if loose. d. Reset control and restart after locating and correcting problem. Contact your Dealer or Distributor if none of the above.
4. PRE LO OIL PRES lamp lights. Engine continues to operate.	4. Indicates engine oil pressure has dropped to 20 psi (138 kPa). If generator is powering critical loads and cannot be shut down, wait until next shutdown period and then follow step 5 procedure. If engine can be stopped, follow procedures in step 5.
5. LO OIL PRES lamp lights. Engine shuts down NOTE: See also step 6.	5. Indicates engine oil pressure has dropped to 14 psi (97 kPa). Check oil level, lines and filters. If oil system is okay but oil level is low, replenish. Reset control and restart. Contact your Dealer or Distributor if oil pressure is not in the range of 35 to 55 psi (21 to 379 kPa).

TABLE 4-1. TROUBLESHOOTING (Continued)

▲WARNING Many troubleshooting procedures present hazards which can result in severe personal injury or death. Only qualified service personnel with knowledge of fuels, electricity, and machinery hazards should perform service procedures. Review safety precautions on inside cover page.

SYMPTOM	CORRECTIVE ACTION
<p>6. OVERCRANK lamp lights and engine stops cranking.</p> <p>or</p> <p>Engine runs, shuts down, and LO OIL PRES lamp lights.</p>	<p>6. Indicates possible fuel system problem.</p> <ul style="list-style-type: none"> a. Check for empty fuel tank, fuel leaks, or plugged fuel lines and correct as required. b. Check for dirty fuel filter and replace if necessary (see <i>Maintenance</i> section). c. Check for dirty or plugged air filter and replace if necessary (see <i>Maintenance</i> section). d. Refer to Step 5. e. Reset the control and restart after correcting the problem. Contact your Dealer or Distributor for service if none of the above.
<p>7. Engine runs and then shuts down, OVERSPEED lamp lights.</p>	<p>7. Indicates engine has exceeded normal operating speed. Contact your Dealer or Distributor for service.</p>
<p>*8. SWITCH OFF lamp flashes.</p>	<p>8. Indicates Run/Stop/Remote switch is in the STOP position which will prevent automatic starting if an automatic transfer switch is used. Move the Run/Stop/Remote switch to the Remote position for automatic starting.</p>
<p>*9. LO FUEL lamp lights. Engine continues to run.</p>	<p>9. Indicates diesel fuel supply is running low. Check fuel supply and replenish as required.</p>
<p>*10. LO FUEL Lamp lights. Engine shuts down and LO OIL PRES lamp lights.</p>	<p>10. Indicates engine has run out of fuel. Check fuel level and replenish as required.</p>
<p>*11. LO ENG TEMP lamp lights. Set is in standby mode but is not operating.</p> <p>(Lamp lights when engine coolant temperature is 70°F (21°C) or lower. Since the lamp goes out after the engine warms up, there should be no cause for alarm even during initial generator set operation.)</p>	<p>11. Indicates engine coolant heater is not operating or is not circulating coolant. Check for the following conditions:</p> <ul style="list-style-type: none"> a. Coolant heater not connected to power supply. Check for blown fuse or disconnected heater cord and correct as required. b. Check for low coolant level and replenish if required. Look for possible coolant leakage points and repair as required. c. Contact your Dealer or Distributor if none of the above.

*12-Light Panel Only.

TABLE 4-1. TROUBLESHOOTING (Continued)

▲WARNING

Many troubleshooting procedures present hazards which can result in severe personal injury or death. Only qualified service personnel with knowledge of fuels, electricity, and machinery hazards should perform service procedures. Review safety precautions on inside cover page.

SYMPTOM	CORRECTIVE ACTION
*12. The FAULT 1 or FAULT 2 fault lamp lights. Engine shuts down immediately, engine runs for several seconds and then shuts down, or engine continues to run.	12. The standard undesignated fault functions are programmed to shut down the set when a fault is sensed. Fault 1 is time delayed while Fault 2 is immediate. The nature of the fault is an optional selection that is determined when the set installation is designed. The undesignated fault functions may also be programmed for non-shutdown or non-time delay.
13. Fault lamp lights but no fault exists. Engine gauges show oil pressure, engine temperature, and frequency (speed) are within normal limits.	13. The monitor board or a sensor may be at fault. Contact your Dealer or Distributor for service.
14. Engine starts from generator control panel but will not start automatically or from a remote panel. (Note: The Run/Stop/Remote switch must be in the Remote position for automatic or remote starting).	14. Remote circuit breaker is tripped, Reset breaker and restart. Contact your Dealer or Distributor if breaker trips after resetting.
15. Engine will not crank.	15. Indicates possible fault with control or starting system. Check for the following conditions: a. Fault lamp on. Correct fault and reset control. b. Poor battery cable connections. Clean the battery cable terminals and tighten all connections. c. Discharged or defective battery. Recharge or replace the battery. d. Contact your Dealer or Distributor for assistance if none of the above.
*16. No AC output voltage.	16. Field breaker is tripped. Reset breaker. Contact your Dealer or Distributor if voltage build up causes breaker to trip.
*17. Green RUN lamp does not light following engine start-up.	17. Indicates possible Start/Disconnect relay failure. Contact your Dealer or Distributor for assistance.

* - 12-Light Panel Only.

Section 5. Maintenance

Establish and adhere to a definite schedule for maintenance and service based on the application and severity of the environment. The table below covers the recommended service intervals for a generator set on STANDBY service. If the set will be subjected to extreme operating conditions, the service intervals should be reduced accordingly. Some of the factors that can affect the maintenance schedule are the following:

- Use for continuous duty (prime power)
- Extremes in ambient temperature
- Exposure to elements
- Exposure to salt water
- Exposure to windblown dust or sand.

Consult with an authorized distributor if the generator set will be subjected to any extreme operating conditions and determine a suitable schedule of maintenance. Use the running time meter to keep an accurate log of all service performed for warranty support. Perform all service at the time period indicated or after the number of operating hours indicated, whichever comes first. Use Table 5-1 to determine the maintenance required and then refer to the sections that follow for the correct service procedures.

⚠ WARNING *Accidental starting of the set can cause severe personal injury or death. Disconnect the battery cables (negative first) when repairs are made to the engine, controls, or generator.*

TABLE 5-1. MAINTENANCE SCHEDULE

MAINTENANCE CHECKS	SERVICE TIME				
	Daily or after 8 hours	Weekly or after 50 hours	Monthly or after 100 hours	6 Months or after 250 hours	Yearly or after 500 hours
Inspect Set	x ¹				
Check Coolant Heater	x				
Check Oil Level		x			
Check Coolant Level		x			
Check Air Cleaner (clean if required)		x ²			
Check Battery Charging System		x			
Drain Fuel Filter(s)		x ⁴			
Drain Water and Sediment from Fuel Tanks		x ⁴			
Check Anti-freeze and DCA Concentration			x		
Check Drive Belt Tension			x ³		
Check Fuel Level			x		
Drain Exhaust Condensate Trap			x		
Check Battery Level and Specific Gravity			x		
Check Generator Air Outlet			x		
Clean Generator Assembly				x	
Change Crankcase Oil and Filter				x ²	
Check Heat Exchanger Plugs (if equipped)				x	
Change Coolant Filter				x	
Clean Crankcase Breather				x ²	
Change Air Cleaner Element				x ²	
Check Governor Linkage				x	
Change Fuel Filters				x	
Clean Cooling System					x

¹ - Check for oil, fuel, cooling, and exhaust system leaks. Check exhaust system audibly and visually with set running and repair any leaks immediately.
² - Perform more often in extremely dusty conditions.
³ - Visually check belts for evidence of slippage.
⁴ - Drain 1 cup or more of fuel to remove water and sediment.

GENERATOR SET INSPECTION

During operation, be alert for mechanical problems that could create unsafe or hazardous conditions. The following sections cover several areas that should be frequently inspected to ensure continued safe operation.

Exhaust System

With the generator set operating, inspect the entire exhaust system visually and audibly including the exhaust manifold, muffler, and exhaust pipe. Check for leaks at all connections, welds, gaskets, and joints and also make sure that exhaust pipes are not heating surrounding areas excessively. If any leaks are detected, shut down the generator set and have leaks corrected immediately.

▲WARNING *Inhalation of exhaust gases can result in serious personal injury or death. Be sure deadly exhaust gas is piped outside and away from windows, doors or other inlets to building.*

Fuel System

With the generator set operating, inspect the fuel supply lines, return lines, filters, and fittings for leaks. Check any flexible sections for cuts, cracks and abrasions and make sure they are not rubbing against anything that could cause breakage. If any leaks are detected, have them corrected immediately.

▲WARNING *Ignition of fuel can cause serious personal injury or death by fire or explosion. Do not permit any flame, cigarette, or other igniter near the fuel system.*

AC Electric System

Check the following while the generator set is operating; otherwise measure load lines L1, L2, and L3 using the appropriate AC meter.

Frequency Meter: The generator frequency should be stable and the reading should be the same as the nameplate rating.

AC Voltmeter: Turn the phase selector switch to each line-to-line phase selection shown on the volts scale (L1-L2, L2-L3, and L3-L1). Read the AC voltmeter using the upper or lower scale as indicated by the scale indicator light. At no load, the line-to-line voltage(s) should be the same as the set nameplate rating.

AC Ammeter: Turn the phase selector switch to each phase selection shown on the amps scale (L1, L2, and L3). Read the ammeter using the upper or lower scale as indicated by the scale indicator light. At no load, the current readings should be zero. With a load applied, each line current should be about the same.

Fault Lamps (Two or Twelve-Fault Lamp Panels): Push the Reset/Lamp switch on the control panel. All indicator lamps should light. Verify that all of the bulbs are on and then release the switch. Replace any bulbs that are burned out.

DC Electrical System

Check the terminals on the battery for clean and tight connections. Loose or corroded connections create resistance which can hinder starting. Clean and reconnect the battery cables if loose. Always disconnect both ends of the negative battery cable. Reconnect one end of the cable to the negative battery terminal and the other end to ground. This will ensure that any arcing will be away from the battery and least likely to ignite explosive battery gases.

▲WARNING *Ignition of explosive battery gases can cause severe personal injury. Do not smoke while servicing batteries.*

▲WARNING *Accidental starting of the generator set can cause severe personal injury or death. Place the control switch in STOP position and disconnect the battery cable before inspecting generator set.*

With the generator set stopped, check for loose belts and fittings, leaking gaskets and hoses, or any signs of mechanical damage. If any problems are found, have them corrected immediately. With the set running, listen for any unusual noises that may indicate mechanical problems and check the oil pressure frequently. Investigate anything that indicates possible mechanical problems.

LUBRICATION SYSTEM

The engine lubrication system must be primed and filled with oil of the recommended classification and viscosity. Refer to the SPECIFICATIONS section for the lubricating oil capacity.

Oil API Classification

The lubricating oil recommended for turbocharged diesel engines is API (American Petroleum Institute) Class CC/CD with a maximum sulphated ash content of 1.85 percent. Oils in this class satisfy the engine manufacturer's recommendations for satisfactory operation under most conditions. A book entitled "Lubricating Oils Data Book" is available from EMA (Engine Manufacturers Association) that lists the commercially available oils by brand name and the corresponding API classification. Once an oil is selected, do not mix it with oils of another classification or brand.

Oil Viscosity

The viscosity of an oil is a measure of its resistance to flow at certain specified temperatures. Oils that can meet both low (0°F or -18°C) and high (212°F or 100°C) temperature flow requirements are labeled as multigrade or multiviscosity oils. Multigrade oils that meet the API classification requirements are recommended for use in the engine by the engine manufacturer. The use of a multigrade oil will improve oil control, improve engine cranking in cold weather, maintain adequate lubrication, and can also contribute to improved fuel economy.

Table 5-2 shows the oil viscosity grades that are recommended for various ambient temperatures. Use only the viscosity grades shown in the table. The engine manufacturer does not recommend the use of a single grade oil.

TABLE 5-2

AMBIENT TEMPERATURE	SAE VISCOSITY GRADE
-13°F (-25°C) and below	See following section
-13°F to 95°F (-25°C to 35°C)	10W-30
14°F (-10°C) and above	15W-40
32°F (0°C) and above	20W-40

When selecting the oil viscosity, pick the grade that is right for the lowest temperature expected. Oil that is too thick may result in a lack of lubrication when the engine is started. Use a lower grade of oil as the ambient temperature reaches the lower end of the scale.

Oil Viscosity for Extreme Cold

The engine manufacturer recommends using a *synthetic* lubricating oil when the ambient temperature is consistently below -13°F (-25°C) and there is no provision to keep the engine warm. Use an SAE5W grade *synthetic* oil provided it meets the following requirements:

- API class CC/CD
- Sulphated ash content does not exceed 1.85 percent.
- Pour point is 9°F (5°C) below the lowest expected temperature (minimum).
- Viscosity is 10,000 mPa•s (maximum) at -31°F (-35°C) and 4.1 mm²/s (minimum) at 212°F (100°C).

Do not use a petroleum base 5W grade oil for extreme cold since it usually will not perform satisfactorily.

Engine Oil Level

Check the engine oil level during engine shutdown periods at the intervals specified in the Maintenance Table. The oil dipstick and oil filter are located on the same side of the engine (see Figure 5-1). The dipstick is stamped with high and low marks to indicate the level of oil in the crankcase. For accurate readings, shut off the engine and wait approximately 15 minutes before checking the oil level. This allows oil in the upper portion of the engine to drain back into the crankcase. Figure 5-2 shows the oil fill cap.

▲WARNING Crankcase pressure can blow out hot oil and cause serious burns. Do NOT check oil while the generator set is operating.

Keep the oil level as near as possible to the high mark on the dipstick. Remove the oil fill cap and add oil of the same API and brand when necessary.

▲CAUTION Do not operate the engine with the oil level below the low mark or above the high mark. Overfilling can cause foaming or aeration of the oil while operation below the low mark may cause loss of oil pressure.

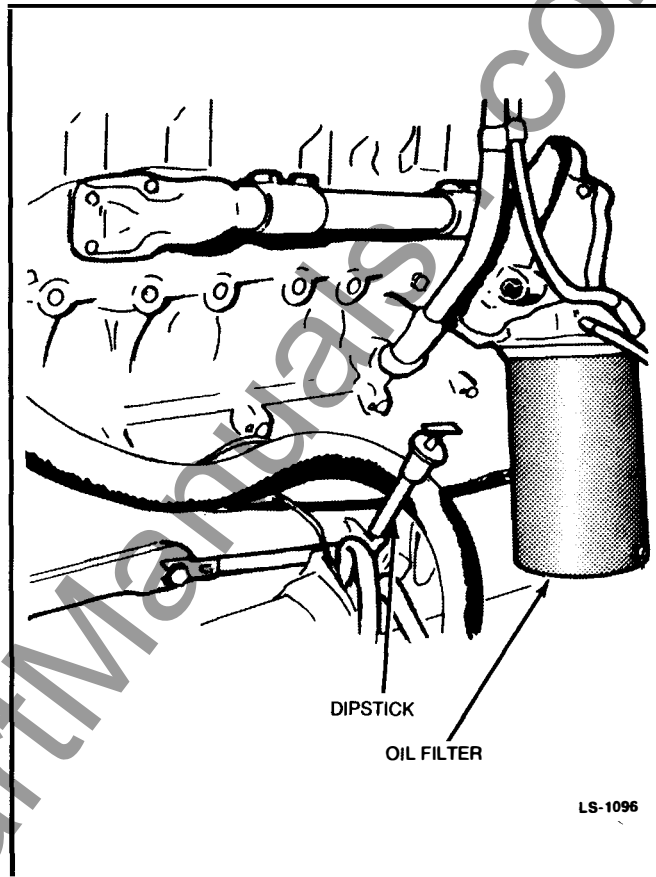

FIGURE 5-1. OIL FILTER AND DIPSTICK LOCATION

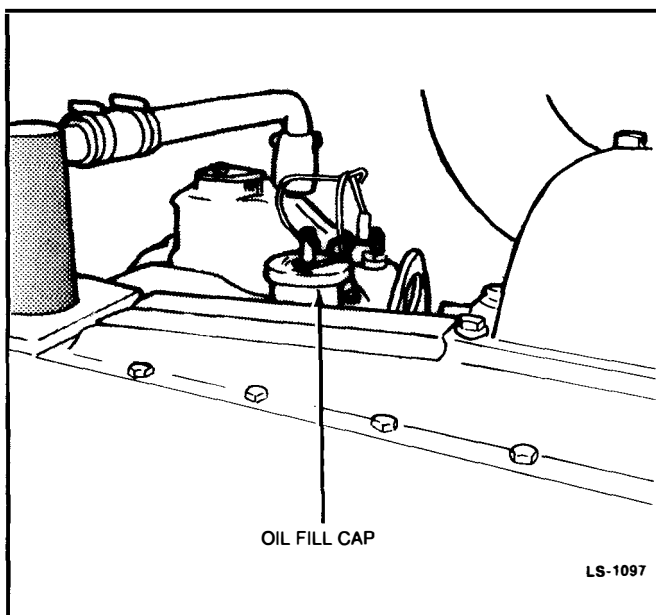

FIGURE 5-2. OIL FILL CAP

Oil and Filter Change

Change the oil and filter at the intervals recommended in Table 5-1. Use oil that meets the API Classification and viscosity requirements.

1. Start the generator set and allow engine to warm up to operating temperature and then shut generator set off. Ensure that Automatic Start switch is at OFF position and the negative (-) battery cable is disconnected to avoid accidental start-up and during this procedure.
2. Remove the oil drain plug or open the drain valve and collect the engine oil in a suitable size waste container. When the crankcase is drained, replace the oil drain plug or close the drain valve. Torque the oil drain plug to 60-70 ft-lb (81-95 N•m).
3. Unscrew the oil filter and discard.
4. Apply a light coat of oil to the gasket sealing surface of the new filter and fill filter with clean, new oil.
5. Install filter and tighten 2/3 turn by hand after the seal touches the sealing surface of the bracket. Do not overtighten.
6. Fill the crankcase with the amount of oil to achieve reading at high mark of dipstick.
7. Reconnect the negative (-) starting battery cable, start the engine and check for oil leaks.
8. Shut off the engine, wait 15 minutes, and then check the oil level. Add oil if required.

⚠WARNING

Crankcase pressure can blow out hot oil and cause serious burns. Do NOT check oil while the generator set is operating.

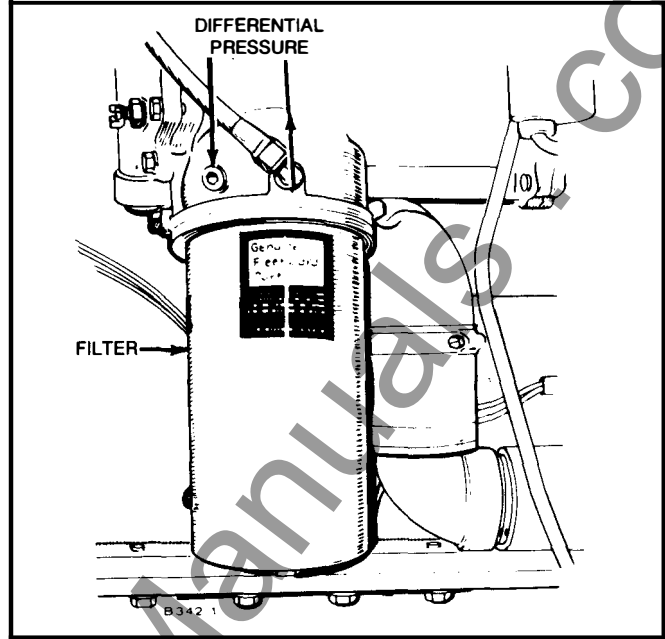

FIGURE 5-3. LUBRICATION OIL FILTER

CRANKCASE BREATHERS

Remove and clean the crankcase breathers at the interval specified in the maintenance table.

To Service

1. Remove wing nut, flat washer and rubber washer holding cover, lift cover and swing away from filter assembly (see Figure 5-4).
2. Lift out breather element, vapor element and gasket.
3. Clean all parts with approved solvent. Dry with compressed air (30 psi maximum [OSHA]).
4. Inspect all parts, replace if necessary.
5. Reassemble filter assembly, replace cover and secure.

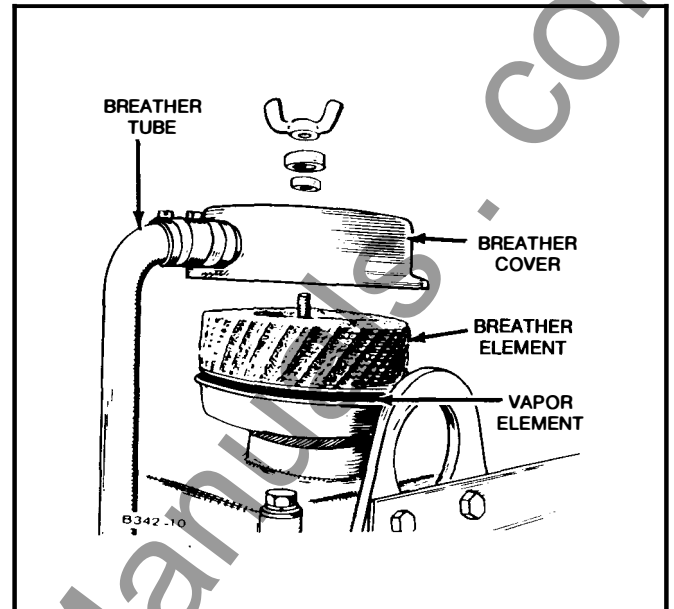

FIGURE 5-4. CRANKCASE BREATHER FILTER

COOLANT SYSTEM

The coolant system must be refilled (radiator and heat exchanger) before being operated. The cooling system capacity of the standard unit with set mounted radiator is shown in the *SPECIFICATIONS* section.

CAUTION *The heater must not be operated while the cooling system is empty or when the engine is running or damage to the heater will occur.*

Coolant Level

Check the coolant level during shutdown periods at the intervals specified in the Maintenance Table. Remove the radiator cap after allowing the engine to cool and if necessary, add coolant until the level is near the top of the radiator. Use a coolant solution that meets the engine manufacturer's coolant requirements.

WARNING *Contact with hot coolant can result in serious burns. Allow cooling system to cool before releasing pressure and removing radiator cap.*

CAUTION *High Engine Temperature Cutoff will shut down engine in an overheat condition only if coolant is sufficiently high to physically contact shutdown switch. Loss of coolant will allow engine to overheat without protection of shutdown device and cause severe damage to the engine. It is therefore imperative that adequate engine levels be maintained to ensure operational integrity of cooling system and engine coolant overheat shutdown protection.*

Coolant Requirements

The water used for engine coolant should be clean, low in mineral content, and free of any corrosive chemicals such as chloride, sulphate, or acid. Generally, any water that is suitable for drinking can be treated for use as engine coolant.

A satisfactory engine coolant inhibits corrosion and if necessary, protects against freezing. To prevent corrosion, the water used for coolant must be precharged with a chemical additive. New engines are shipped with a precharge water filter that automatically adds an anti-corrosion chemical to the coolant.

The precharge water filter is compatible with plain water and all permanent type antifreezes EXCEPT those with a methoxy propanol base.

Cooling systems that are subject to freezing conditions must also be protected with a permanent type antifreeze. Mix the water and antifreeze in the proportion recommended by the supplier for the lowest expected ambient temperature. Do not use an antifreeze that contains anti-leak additives. The water filter element will trap the additives and possibly become clogged.

▲WARNING *Contact with hot coolant can result in serious burns. Do not bleed hot, pressurized coolant from a closed cooling system.*

Filling the Cooling System (Standard Radiator and Heat Exchanger Sets)

Remove the cooling system pressure cap and fill the system with water or a water / antifreeze mixture. On the initial fill, the precharge water filter will automatically add the required anti-corrosion chemicals to the cooling system.

When the engine is first started, remove the pressure cap and monitor the coolant level. As trapped air is expelled from the system, the coolant level will drop and additional coolant should be added. Replace the pressure cap when the coolant level is stable.

▲CAUTION *Be sure the electric solenoid valve used with city water cooled sets is open before initial starting of unit to allow coolant chambers to fill. Otherwise overheating and damage to the engine might result.*

Remote Radiator Coolant Precharge

The large quantities of coolant used in a remote radiator installation will require precharging with a separate anti-corrosion additive. The precharge water filter will not provide adequate anti-corrosion protection for the large capacities of most remote systems.

▲WARNING *Diesel Coolant Additive (DCA) is an engine corrosion inhibitor. The DCA manufacturer rates it as moderately hazardous. That is, it may involve both irreversible and reversible changes; not severe enough to cause death or permanent injury.*

Exposure can cause irritation to eyes, nasal passages and exposed skin. Protective rubber or plastic gloves, goggles and dust (3M Company #8710 or equal) respirators must be used when handling DCA powder.

If exposed to DCA or coolant using DCA, flush eyes and skin with clean water. Remove contaminated clothing and launder before use.

Clean area of dry spills and place DCA in an approved chemical contamination container.

Engine coolant containing DCA must be disposed of per local, state, and federal regulations in approved chemical contamination containers.

A separate precharge DCA (diesel coolant) in powder, liquid or brickett is available from the engine manufacturer. The following recommendations are provided for mixing the coolant with the engine manufacturer's precharge additive.

Testing the DCA Concentration: Over a period of time, the DCA additive will become depleted and it will be necessary to add more DCA chemical to maintain adequate corrosion protection. The engine manufacturer has a testing kit available for measuring the concentration of DCA chemical in the system. Determine the DCA concentration before adding more DCA to the system. Too low a concentration will allow corrosion to start. Too great a concentration may cause sludge to form in the water filter. Instructions for testing the coolant are provided with the kit.

Coolant Filter

When changing the coolant filter on a new engine, replace the DCA precharge element filter with the DCA service element filter. After the third element change, check the DCA concentration to ensure that adequate corrosion protection is maintained. Each time the cooling system (set mounted radiator) is drained, install a new DCA precharge element water filter to bring the DCA concentration up to the recommended level.

To Service:

1. Close the shutoff valves (Figure 5-5).
2. Unscrew the coolant filter and discard.
3. Apply a light coat of lubricating oil to the gasket surface.
4. Install a new filter and tighten by hand until the seal just touches the filter head. Tighten an additional one-half to three-fourths turn.
5. Open the shutoff valves.

CAUTION Do not use antifreeze with an anti-leak formula. The stop leak element can prevent or retard the coolant flow through the filter, thereby eliminating the filtering process completely.

CAUTION Before flushing and cleaning, de-energize engine coolant heater.

Flushing and Cleaning

The cooling system must be clean and free of rust and scale if it is to perform properly. Use only coolant that meets the engine manufacturer's requirements.

Chemical Cleaning: Thoroughly clean the cooling system if rust and scale have collected on the engine water jacket or in the radiator. Rust and scale slow down heat absorption and can block the coolant flow. Use a good cooling system cleaner such as sodium bisulphate or oxalic acid and follow the instructions provided by the supplier. Follow up by neutralizing and flushing with clean water.

Flushing: Flush the radiator and block after cleaning or before refilling the system with new coolant. Open the upper and lower radiator hose connections, and install the radiator cap. Attach a flushing gun nozzle to the lower radiator hose connection and let the water run until the radiator is full. When full, gradually apply air pressure to avoid damaging the core.

CAUTION Excessive air pressure while starting the water flow could split the radiator core. Apply air pressure gradually to avoid damage.

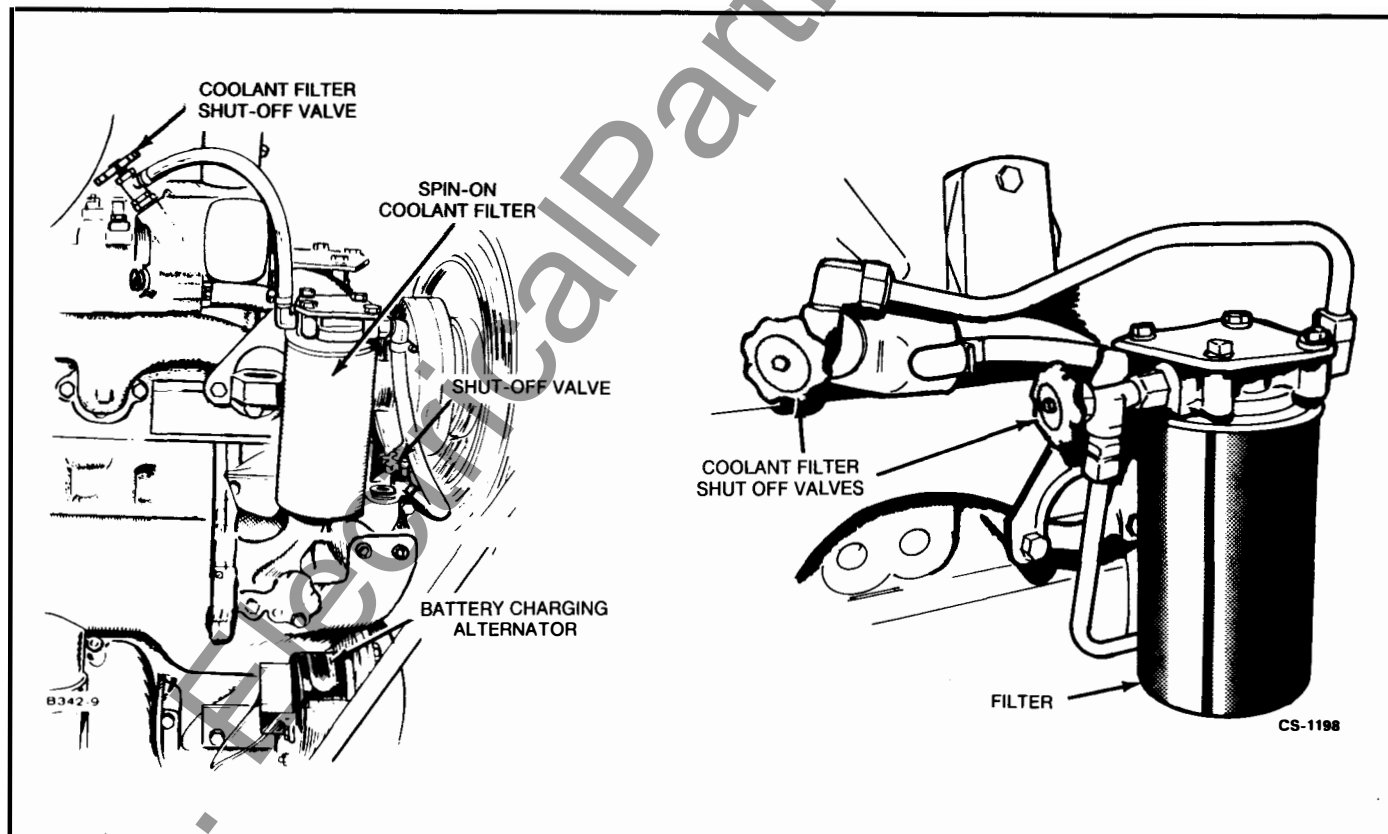

FIGURE 5-5. COOLANT FILTER

Shut off the air and allow the radiator to refill. Repeat flushing procedure until the water coming from the radiator is clean.

To flush the engine block, first remove the thermostat to allow the water to fill the block. Attach the flushing gun to the upper radiator hose and fill the block with water. Restrict the lower radiator hose opening until the block is filled. Apply air pressure and force water from the lower opening. Repeat until the water coming from lower radiator hose is clean.

Replace the thermostat and all hoses and refill cooling system.

Heat Exchanger Plugs

Check the zinc plugs in the heat exchanger and replace if they are eroded to less than half their original length. The frequency of replacement is dependent on the chemical reaction that occurs when the plugs are in contact with the raw water.

Coolant Heater

Check the operation of the coolant heater by verifying that hot coolant is being discharged from the outlet hose (see Figure 5-6). For efficient operation and maximum life, clean the coolant heater whenever the cooling system is drained for flushing.

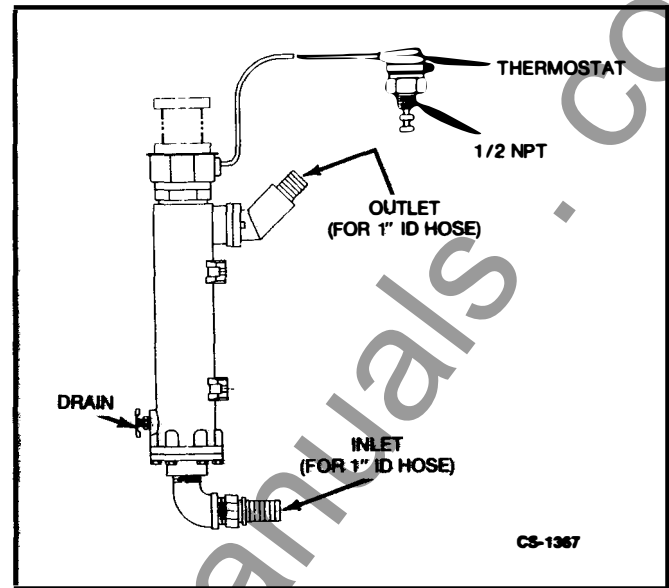

FIGURE 5-6. COOLANT HEATER

FUEL SYSTEM

The engine has been primarily designed to operate on No. 2 diesel fuels since such fuels have a higher energy content and are generally lower in cost. The engine will also operate satisfactorily on No. 1 fuel or other similar fuels if they meet certain specifications. Consult the engine manufacturer for the specific requirements if using a non-standard fuel.

Fuel Handling Precautions

Take appropriate precautions to prevent the entrance of dirt, water, or other contaminants into the fuel system. Filter or strain the fuel as the tank is filled.

⚠ WARNING *Ignition of fuel can cause serious personal injury or death by fire or explosion. Do not permit any flame, cigarette, or other igniter near the fuel system.*

To avoid condensation problems, keep fuel supply tanks as full as possible by filling up each time the engine is used. In cold weather, warm fuel returning from the injectors heats the fuel in the supply tank. If the fuel level is low, the upper portion of the tank tends to form condensation. In warm weather, both the fuel and the tank will be warm during the daytime. At night, cool air tends to lower the temperature of the tank more rapidly than the temperature of the fuel. If the fuel level is low, the upper portion of the tank will cool more rapidly and tend to form condensation.

Condensation (water) can cause clogging of fuel filters as well as freezing problems. In addition, water mixing with the sulphur in the fuel forms acid which can corrode and damage engine parts.

Fuel Filter

The filter (see Figure 5-7) is a spin-off throw-away unit. A water drain is situated at the bottom of the filter case. This should be used to drain off moisture either daily or at the end of every exercise period, depending on unit application. Fill the new filters with diesel fuel and put a light coat of fuel on the sealing gasket. Install and tighten by hand until the gasket just touches the filter head. Tighten an additional one-half to three-fourths of a turn. Periodically remove the drain plug to drain off moisture and sediment at the interval specified in the Maintenance Table.

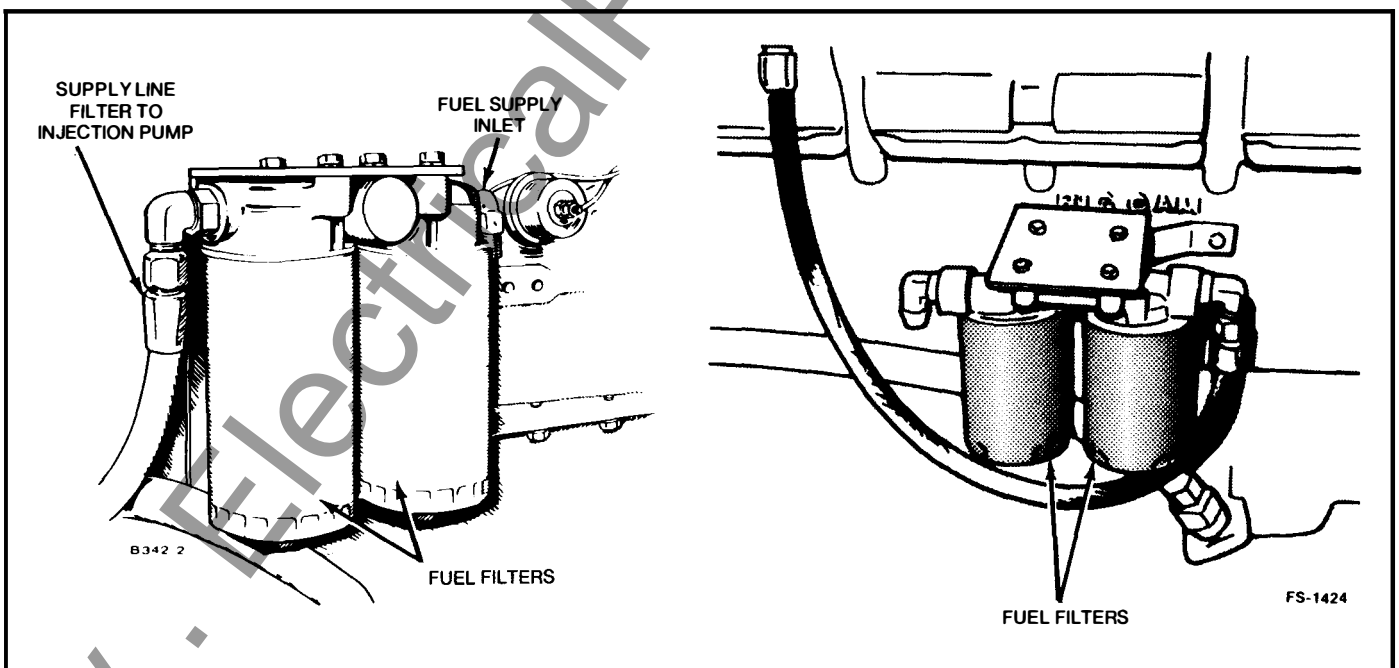

FIGURE 5-7 FUEL FILTERS

AIR CLEANER

The engine air intake components should be checked at the interval indicated in Table 5-1. The frequency of cleaning or replacing air cleaner filter elements is primarily determined by the conditions that the generator set operates in. The standard air cleaner and optional heavy duty air cleaner contain a paper cartridge filter element which can be cleaned and reused if not damaged, or discarded and replaced.

To Service the Air Cleaner: See Figure 5-8 and 5-9.

1. Loosen fastener(s) and remove air cleaner housing end cap.
2. Remove the air filter element from the filter housing.
3. To clean, blow low pressure compressed air (30 psi/207 kPa) through the element from the clean side. Hold the nozzle at least 1 inch (25 mm) away to avoid damaging the element.
4. Soak the filter for at least 15 minutes in water and Donaldsons D1400 solvent (or equivalent other cleaning solvent) to remove soot and carbon as well as dirt.
5. Rinse with clean water (low pressure) and allow to air dry. Do not blow dry with compressed air. Reinstall when the filter element is dry. Replace the filter after two cleanings to avoid restricting the airflow.

CAUTION

Filters should be handled with care to prevent damage. If the filter does become damaged, install recommended replacement part.

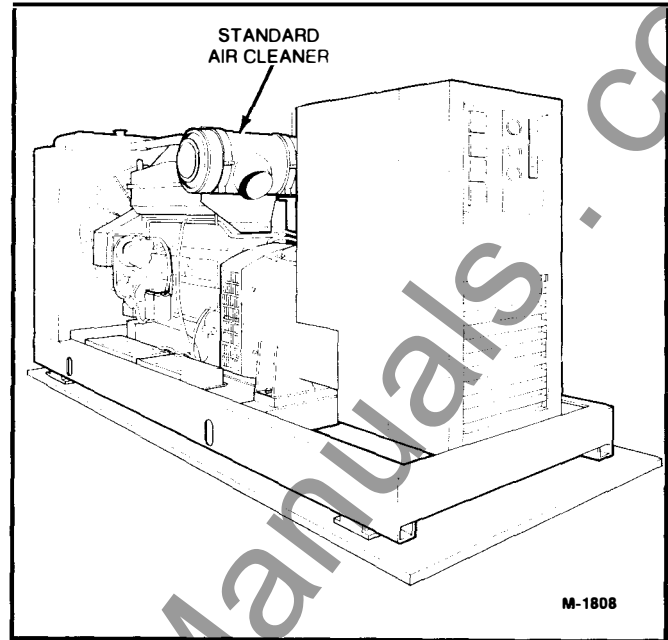

FIGURE 5-8. STANDARD AIR CLEANER

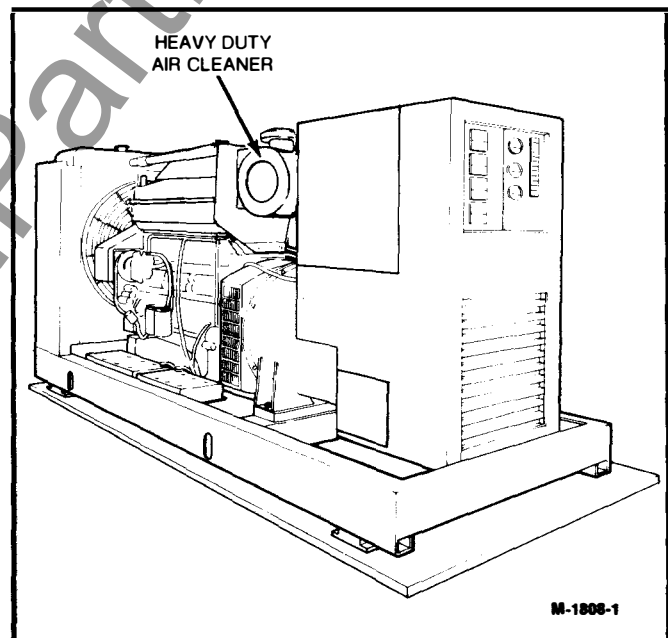

FIGURE 5-9. HEAVY DUTY AIR CLEANER (OPTIONAL)

BATTERIES

Check the condition of the starting batteries (see Figure 5-10) at the interval specified in the Maintenance Table. See that connections are clean and tight. A light coating of non-conductive grease will retard corrosion at terminals. Keep the electrolyte at the proper level above the plates by adding distilled water. Check specific gravity using a hydrometer and recharge if below 1.260.

▲WARNING *Ignition of explosive battery gases can cause severe personal injury. Do not smoke while servicing batteries.*

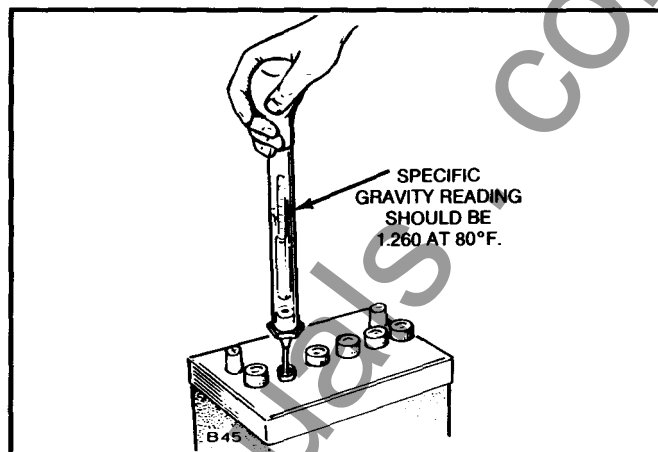

FIGURE 5-10. BATTERY

www.ElectricalPartManuals.com

Section 6. Adjustments

ELECTRIC GOVERNOR ADJUSTMENT

Generator frequency is in direct ratio to engine speed which is controlled by the governor. The generator set uses a Cummins model EFC electric governor.

Governor is adjusted at factory; it should not require field adjustment.

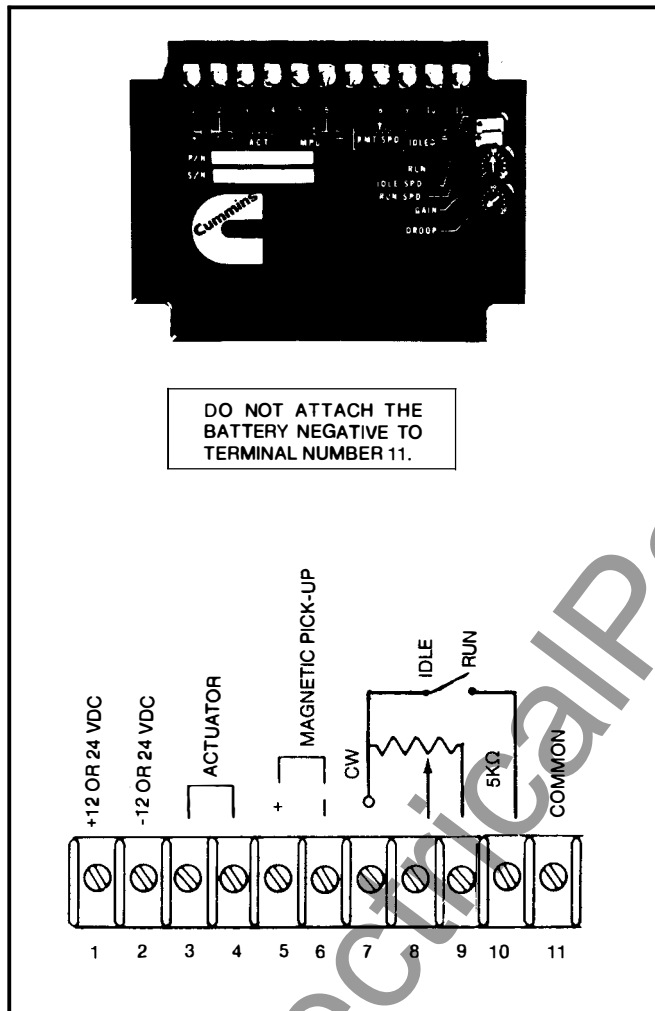

FIGURE 6-1. EFC GOVERNOR CONTROL

The governor control has four potentiometers for making adjustments.

Gain

The gain control is a one-turn potentiometer. It is used to adjust the sensitivity of the governor. A clockwise rotation of the potentiometer will shorten the response time to load changes.

Drop

The Droop control is a one-turn potentiometer. It is adjustable for zero % (isochronous) to 5% speed droop. Fully counterclockwise rotation will decrease the speed droop.

Idle Speed

The Idle Speed control is a 20-turn potentiometer for adjusting the idle speed. A clockwise rotation will increase the idle speed.

Run Speed

The Run Speed control is a 20-turn potentiometer for setting the desired no-load governed speed. A clockwise rotation will increase the run speed.

Preliminary Adjustments

1. Idle Speed potentiometer.
 - a. Turn the screw counterclockwise 20 turns.
 - b. Turn the screw clockwise 10 turns.
 - c. This will set the idle speed potentiometer to its mid position.
2. Run Speed potentiometer.
 - a. Turn the screw counterclockwise 20 turns.
 - b. Turn the screw clockwise 10 turns.
 - c. This will set the run speed potentiometer to its mid position.
3. Gain potentiometer.
 - a. Turn the screw fully counterclockwise.
4. Droop potentiometer.
 - a. Turn the screw fully counterclockwise for isochronous operation.
 - b. Turn the screw to approximately 40 for 3 percent droop.
 - c. Turn the screw to approximately 80 for 5 percent droop.

Governed Speed Adjustment

Generators which are to operate at 60 Hz full load, must have the engine no load governed speed adjusted to:

- 60.0 Hz (1800 RPM) for isochronous operation
- 61.8 Hz (1854 RPM) for 3% speed droop
- 63.0 Hz (1890 RPM) for 5% speed droop

For generators which are to operate at 50 Hz full load, the engine no-load governed speed must be adjusted to:

- 50.0 Hz (1500 RPM) for isochronous operation
- 51.5 Hz (1545 RPM) for 3% speed droop
- 52.5 Hz (1575 RPM) for 5% speed droop

Droop Adjustment - Isochronous Operation

For isochronous operation, the droop potentiometer must be turned fully counterclockwise and will not require any further adjustment.

Gain Adjustment

1. Close the main line circuit breaker and apply approximately 1/4 of the rated load.
2. Make sure the engine speed is constant. If the engine speed is constant, turn the GAIN potentiometer clockwise slowly until the engine speed is not constant.
 - a. Slowly turn the potentiometer counterclockwise until a constant speed is achieved. Turn the potentiometer counterclockwise an additional 1/2 division.

Fine Speed Adjustment

After the gain adjustment is made, the full load governed engine speed may require a minor adjustment to equal the desired speed (i.e. 60 Hz, 1800 RPM or 50 Hz, 1500 RPM). Use the SPEED ADJUST potentiometer on the engine instrument panel for fine speed adjustments of less than ± 100 RPM.

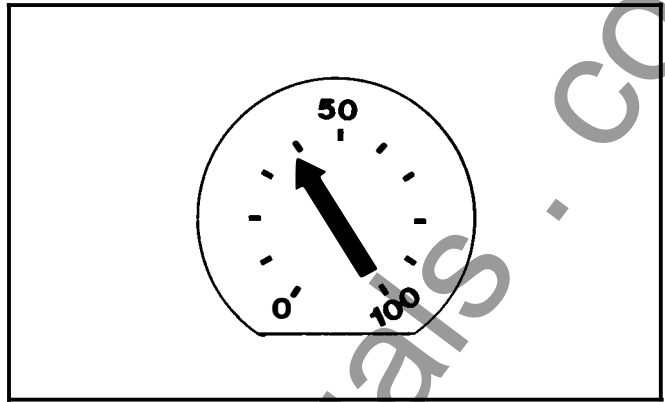

www . ElectricalPartManuals . com



Onan

Onan Corporation
1400 73rd Avenue N.E.
Minneapolis, MN 55432
612-574-5000
Telex: 275477
Fax: 612-574-8087

Onan is a registered trademark of Onan Corporation
Cummins is a registered trademark of Cummins Engine Company