

SIEMENS

Series 81000™ Controller

with Drawout 96H3 or 97H3 Vacuum Contactors
2300, 4000, or 6600 Volts AC (Utilization Voltage)
2400, 4160, or 6900 Volts AC (Distribution Voltage)

Instructions

Installation

Operation

Maintenance

SGIM-9068B

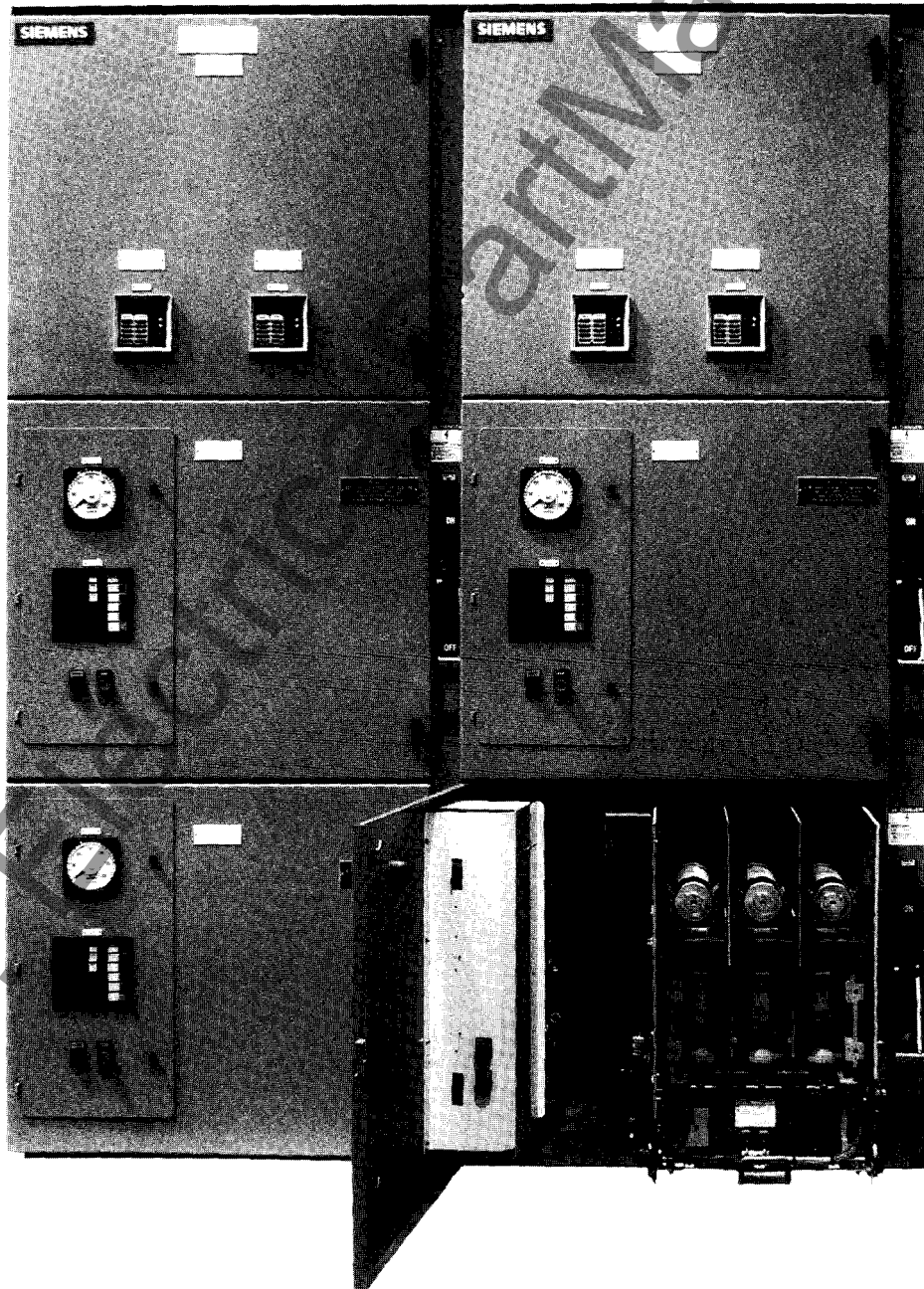

DANGER



Hazardous voltages.

Will cause death, serious personal injury or equipment damage.

Always de-energize and ground the equipment before maintenance. Read and understand this instruction manual before installing, operating, or maintaining the equipment. Maintenance should be performed only by qualified personnel. The use of unauthorized parts in the repair of the equipment, altering of the design, or tampering by unqualified personnel will result in dangerous conditions which will cause serious personal injury or equipment damage. Follow all safety instructions contained herein.

IMPORTANT

The information contained herein is general in nature and not intended for specific application purposes. It does not relieve the user of responsibility to use sound practices in application, installation, operation, and maintenance of the equipment purchased. Siemens reserves the right to make changes in the specifications shown herein or to make improvements at any time without notice or obligations. Should a conflict arise between the general information contained in this publication and the contents of drawings or supplementary material or both, the latter shall take precedence.

QUALIFIED PERSON

For the purpose of this manual and product labels, a qualified person is one who is familiar with the installation, construction, operation, or maintenance of the equipment and the hazards involved. In addition, this person has the following qualifications:

- (a) **is trained and authorized** to energize, de-energize, clear, ground, and tag circuits and equipment in accordance with established safety practices.
- (b) **is trained** in the proper care and use of protective equipment such as rubber gloves, hard hat, safety glasses or face shields, flash clothing, etc., in accordance with established safety practices.
- (c) **is trained** in rendering first aid.

GENERAL

These instructions do not purport to cover all details or variations in equipment, nor to provide for every possible contingency to be met in connection with installation, operation, or maintenance. Should further information be desired or should particular problems arise which are not covered sufficiently for the purchaser's purposes, the matter should be referred to the local Siemens sales office.

The contents of this instruction manual shall not become part of or modify any prior or existing agreement, commitment or relationship. The sales contract contains the entire obligation of Siemens Power Transmission & Distribution^{LLC}. The warranty contained in the contract between the parties is the sole warranty of Siemens Power Transmission & Distribution^{LLC}. Any statements contained herein do not create new warranties or modify the existing warranty.

Table of Contents

Introduction and Safety	2	Type 3UA Thermal Overload Relay	33-36
Introduction	2	General	33
Qualified Person	2	Overload Relay Operation	33
Signal Words	2	Application	33
Dangerous Procedures	2	Cyclic Starting	33
Field Service Operation	2	Cyclic Loading	34
General Description	3-19	Single-Phasing	34
General	3	Causes for Relay Tripping	34
Basic Impulse Level	4	Operational Checks	34
Dielectric (Power Frequency Withstand) Test	4	Test Procedures	34
Ratings	4	Operational Test	35
Medium Voltage Contactors	4	100% Current Test	35
Surge Protection	5	Coordination with Current-Limiting Motor Fuses	35
Isolation and Automatic Shutter Mechanisms	5	Operation	37-39
Racking Mechanism and Mechanical Interlocks	7	Pre-Energization Check	37
Medium Voltage Compartment Door Interlock	7	Dielectric Test	38
Contactor Interlock	7	Energizing Equipment	38
Test Switch	8	Maintenance	40-45
Mechanical Latch	8	Introduction	40
Detent Lever	8	General	40
Contactor Engagement Warning Light	9	Recommended Maintenance and Lubrication	40
Line Switch Interlock (LSI)	9	Mechanical and Electrical Operation of the	
Racking Switch Interlock (RSI)	9	Controller	40
Power Fuses (Current-Limiting)	12	Vacuum Contactors	41
Use of 96H3 or 97H3 Contactor		Shutter Mechanism	41
in Other Cell Types	12	Racking Mechanism Adjustment	41
Receiving, Handling and Storage	20-21	Mechanical Interlocks	44
Receiving	20	Electrical Interlocks	44
Handling	20	Electrical Joints and Terminals	44
Skid Removal	21	Periodic Cleaning	45
Contactor Removal	21	Dielectric Test	45
Storage	21	Overload Relay Checks	45
Installation	22-30	Recommended Torque	45
Introduction	22	Maintenance After a Fault has Occurred	46
Operating Environment	22	Introduction	46
Site Preparation and Mounting	22	General	46
General Pre-Installation Inspection	22	Inspection	46
Grounding	22	Enclosures	46
Electrical Connection	22	Terminals and Internal Conductors	46
Contactor Installation	24	Contactor	46
Preinstallation Checks	24	Overload Relays	46
Installation	24	Fuse Holders	46
Power Cable Termination	30	Fuses	46
Series 81000 Controllers	30	Troubleshooting	47-49
Termination of Lead-Covered Cable	30	General	47
Termination of Shielded Cables	30		
Siemens Advanced Motor Master System	31-32		
SAMMS-MV System Description	31		
Configuration	31		
Protective Functions	31		
Starter Types	31		
Diagnostics	32		
SAMMS-MV Device Models	32		
SAMMS-MV Instructions	32		

Introduction and Safety

Introduction

The Series 81000™ family of Medium Voltage Controller equipment is designed to meet all applicable NEMA standards. Successful application and operation of this equipment depends as much upon proper installation and maintenance by the user as it does upon the careful design and fabrication by Siemens.

The purpose of this Instruction Manual is to assist the user in developing safe and efficient procedures for the installation, maintenance and use of the equipment.

Contact the nearest Siemens representative if any additional information is desired.

	⚠ DANGER
	Hazardous Voltages. Will cause death, serious personal injury or property damage. Always de-energize and ground the equipment before maintenance. Installation, operation, or maintenance should be performed only by qualified persons thoroughly familiar with the equipment, instruction manuals, and drawings. Read and understand this instruction manual before using the equipment.

Qualified Person

For the purpose of this manual and product labels, a **Qualified Person** is one who is familiar with the installation, construction or operation of the equipment and the hazards involved. In addition, this person has the following qualifications:

- Training and authorization to energize, de-energize, clear, ground and tag circuits and equipment in accordance with established safety practices.
- Training in the proper care and use of protective equipment such as rubber gloves, hard hat, safety glasses, face shields, flash clothing, etc., in accordance with established safety procedures.
- Training in rendering first aid.

Signal Words

The signal words "Danger", "Warning" and "Caution" used in this manual indicate the degree of hazard that may be encountered by the user. These words are defined as follows:

Danger - Indicates an imminently hazardous situation which, if not avoided, **will** result in death or serious injury

Warning - Indicates a potentially hazardous situation which, if not avoided, **could** result in death or serious injury.

Caution - indicates a potentially hazardous situation which, if not avoided, **may** result in minor or moderate injury.

Dangerous Procedures

In addition to other procedures described in this manual as dangerous, user personnel must adhere to the following:

1. **Always work only on de-energized equipment. Always de-energize a contactor, and remove it from the equipment before performing any tests, maintenance or repair.**
2. **Always let an interlock device or safety mechanism perform its function without forcing or defeating the device.**

Field Service Operation

Siemens can provide competent, well-trained Field Service Representatives to provide technical guidance and advisory assistance for the installation, overhaul, repair and maintenance of Siemens equipment, processes and systems. Contact regional service centers, sales offices or the factory for details, or telephone Siemens Field Service at 1-800-241-4453.

General Description

Description

General

The Siemens Series 81000™ controller is an integrated system of contactors and components arranged for convenient access within a common enclosure consisting of one or more free-standing structural sections. Each section is 36 inches wide, 36 inches deep, and 90 inches high (100 inches high with top mounted main bus). Refer to **Figure 1**.

The Series 81000 controller is a modular design which can be arranged to meet specific customer specifications and needs. Each section is designed to accept up to three starters with one low voltage control panel for each starter. The unit height may be either 30, 45 or 60 inches.

The upper units of 1-high and 2-high controllers may contain a low voltage panel or space for future starters.

In general, each starter unit is divided into medium voltage and low voltage compartments, each with its own separate door and interior barriers between the two. The medium voltage compartment contains the contactor power cell module upon which the shutter mechanism, racking mechanism, line and load connections, mechanical and electrical interlocks are

mounted. The cell module can be either 29.88 inches (upper or middle cells) or 33.50 inches (lower cell) deep.

The medium voltage compartment also houses the current transformers and the contactor.

In order to open the medium voltage unit door, the contactor must be de-energized and completely racked-out, and the door unlatched. Low voltage compartment doors may be opened without disconnecting the power, but this must be done with extreme care and caution.

The electrical power is distributed through the optional main horizontal bus which extends the entire length of the controller. The bus may be mounted in the rear of the upper compartment or inside a 10 inch high top hat. See **Figure 2**.

Each vertical section containing provisions for drawout contactors is fed by cables or a vertical bus system which is connected to the horizontal bus. The cables or vertical bus system in turn supply power through the stab assembly mounted on the cell module.

The horizontal and vertical bus or cable system is isolated from the front by means of barriers.

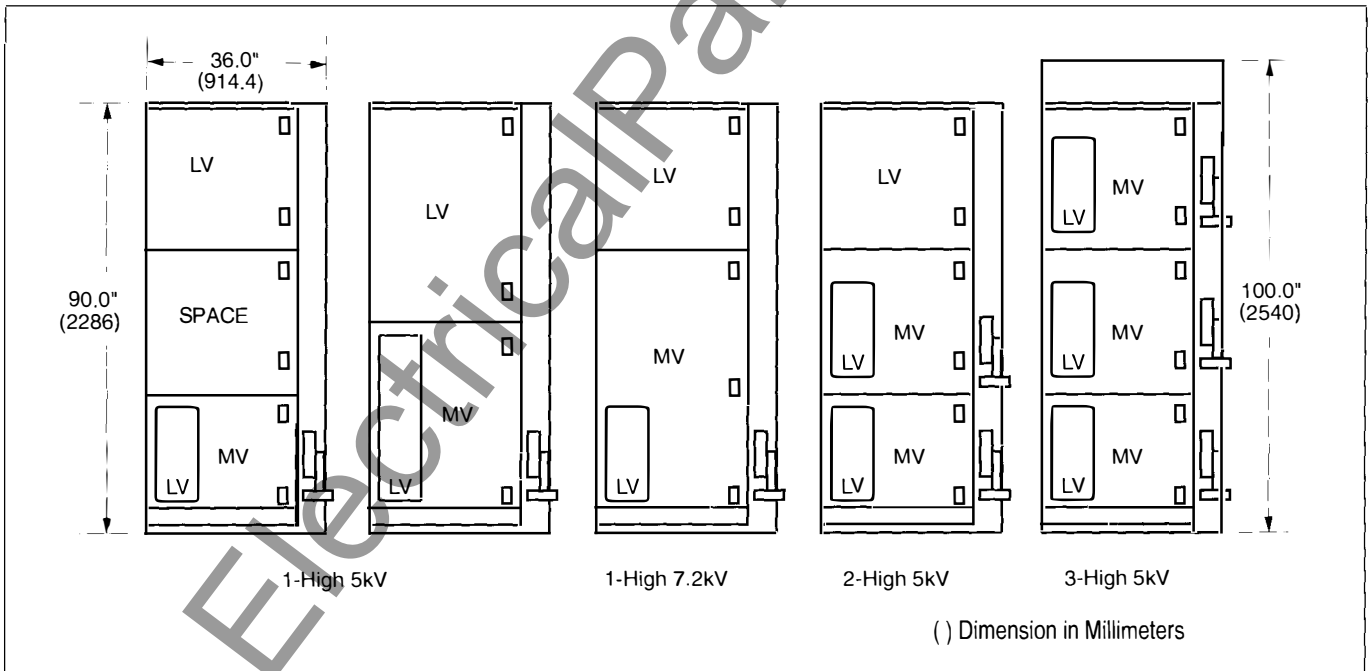

Figure 1. Typical Construction

General Description

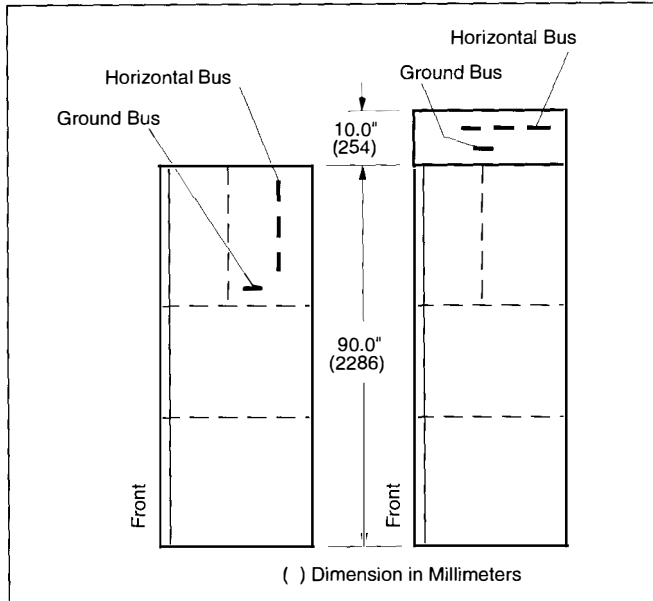

Figure 2. Alternate Bus Locations (Side View)

Basic Impulse Level

All Series 81000 controllers have a basic impulse level of 60kV crest, excluding control transformers, starting reactors and autotransformers.

Dielectric (Power Frequency Withstand) Test

All controllers are factory tested at 2.25 x nameplate voltage plus 2000 volts for one minute.

Table 2. Maximum motor fuse and transformer fuse rating

Fused Contactor Type	3 Phase Horsepower Rating at Utilization Voltage									Maximum Motor Fuse Rating	Transformer Loads				Maximum Transf. Fuse Rating
	2300V			4000-4600V			6600V				Maximum 3-Phase kVA at Distribution Voltage				
	Syn. Motors	Syn. Motors	Ind. Motors	Syn. Motors	Syn. Motors	Ind. Motors	Syn. Motors	Syn. Motors	Ind. Motors						
	0.8PF	1.0PF		0.8PF	1.0PF		0.8PF	1.0PF							
2400V	4160V	4800V	6900V												
96H35 97H35	1500	1750	1500	2500	3000	2500	—	—	—	24R	1500	2500	2500	—	450E
96H37 97H37	—	—	—	—	—	—	4000	5000	4000	24R	—	—	—	1500	200E

Ratings

The Series 81000 controllers are rated in accordance with **Table 1**, and as shown on the nameplate on front of the enclosure.

Medium Voltage Contactors

Siemens Types 96H35 or 97H35 (5kV) and Types 96H37 or 97H37 (7.2kV) contactors are used in Series 81000 controllers. The 96H35 or 97H35 contactors can accept 5kV power fuses rated 2R through 24R. The 96H37 or 97H37 contactors can accept 7.2kV fuses rated 2R through 24R.

Type 96H35 or 97H35 contactors with single or double barrel fuses can be installed in any compartment of one, two and three-high 5kV controllers. Type 96H37 or 97H37 contactors can only be installed in one-high 7.2kV controllers, or in two-high controllers with 45 in. high compartments

Table 1. 96H3 or 97H3 Contactor Ratings

Contactor Type	Maximum Voltage Rating	Enclosed Continuous Ampere Rating	Interrupting Capacity		Impulse Level (BIL) (kV)
			Unfused Class E1 Controller (kA)	Fused Class E2 Controller (MVA)	
96H35 97H35	5.0kV	360	5kA	200 @ 2.3kV 350 @ 4.0kV 400 @ 4.6kV	60
96H37 97H37	7.2kV	360	4.2kA	570 @ 6.6kV	60

Auxiliary Contacts: Each contactor is equipped with 2 N.O. and 2 N.C. auxiliary contacts for customer use. These contacts are rated 600V, 10A (NEMA Class A600).

General Description

Surge Protection

The 96H3, 97H3, and 96H6 vacuum contactors are suitable for application without protection from surges related to switching with vacuum, except for jogging or inching duty with small (under 100HP) motors. For such applications, metal-oxide surge arrestors or surge limiters should be specified.

Regardless of the switching means employed, if the insulation integrity of the motor is suspect, such as for very old machines, it may be desirable to add surge protection for the machine, or to consider upgrading the machine to modern insulation standards.

Isolation and Automatic Shutter Mechanisms

Non-load break finger type stab assemblies provide the means for manual isolation of the power circuit, in accordance with NEMA Standards requirements.

The shutter mechanism operation is directly controlled by the position of the racking mechanism, and the movable insulated shutter is linked to the racking cams, **Figure 3**.

As the handle of the racking mechanism is moved towards the ON position, the insulated shutter uncovers the line stab assembly just prior to engagement of the contactor line and load stab fingers, **Figure 4**.

In the reverse operation, when the handle is moved towards the OFF position, the insulated shutter covers the line stab assembly, thus effectively isolating all live high voltage parts, **Figure 5**.

Labels on the stationary shutter clearly indicate if the isolating means is OPENED (disengaged, i.e. drawout carriage disengaged from line stabs, and shutter covering line stabs).

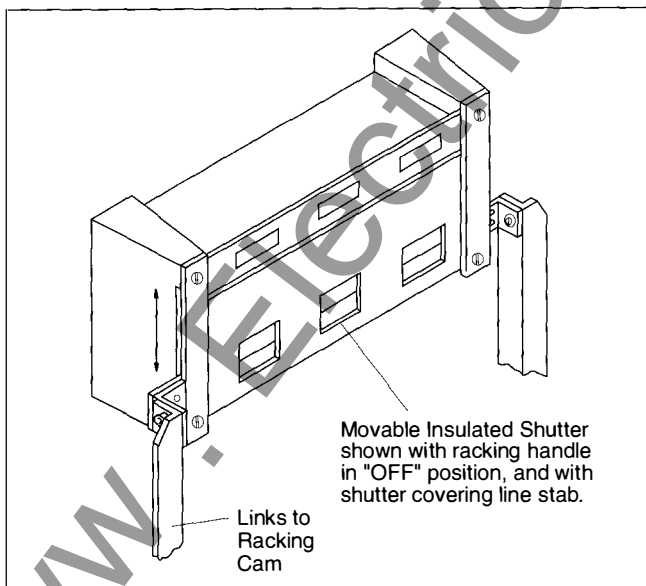

Figure 3. Shutter Mechanism

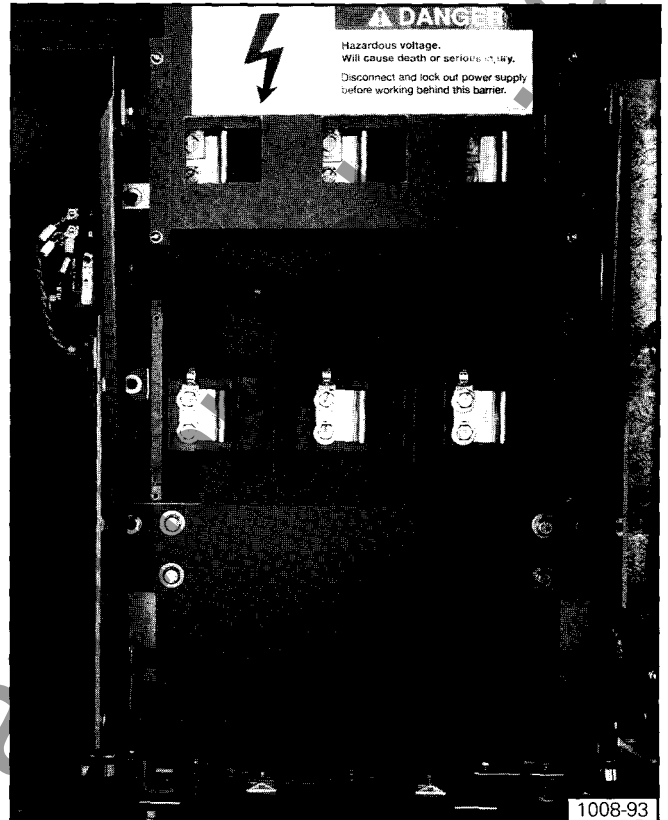

Figure 4. Shutter in ON Position (Upper Stabs Exposed).
(Note: Shutter shown blocked open for photo purposes only.)

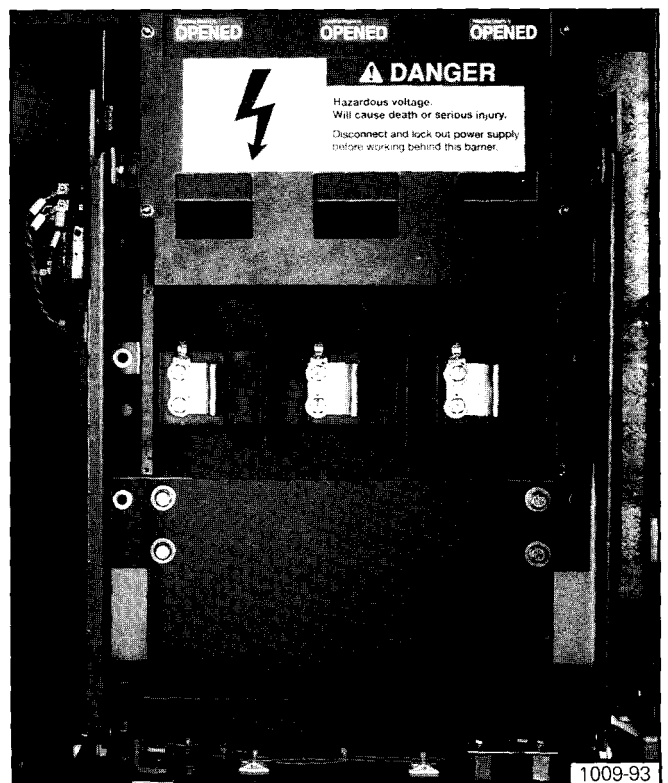

Figure 5. Shutter in OFF Position (Upper Stabs Hidden)

General Description

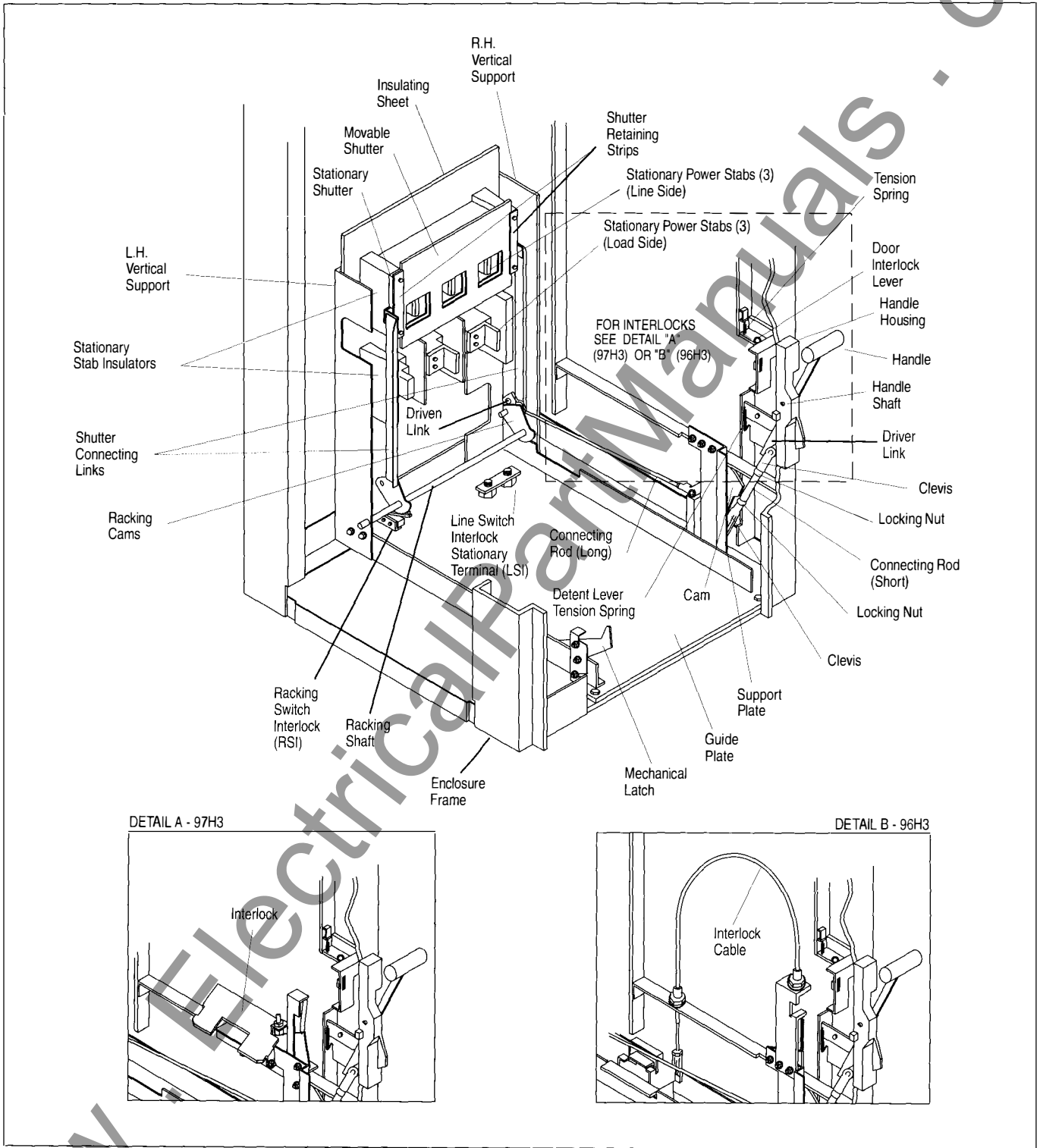

Figure 6. Cell Module

General Description

Racking Mechanism and Mechanical Interlocks

Racking of drawout contactors is accomplished using a compound four-bar mechanism operated by an external, enclosure mounted handle. The handle can be locked with up to three padlocks in the OFF position.

Mechanical and electrical interlocks are incorporated in the racking mechanism to perform the following functions.

Medium Voltage Compartment Door Interlock

The racking handle is interlocked with the door such that the handle cannot be moved to the ON position while the door is open. Refer to **Figure 7**.

The door-handle interlock (item 2 in **Figure 7**) prohibits closing or opening of the medium voltage compartment door except when the handle is in the OFF position. The flat profile on the end of the handle shaft will not allow the door-handle interlock to pass in or out unless the handle is in the OFF position. Refer to **Figure 7**.

	⚠ DANGER
	Hazardous voltages.
	Will cause death, serious personal injury, or equipment damage.
	The door-handle interlock should be defeated only in the event of a malfunction in the racking mechanism. Never defeat this interlock if the red contactor engagement light is on.

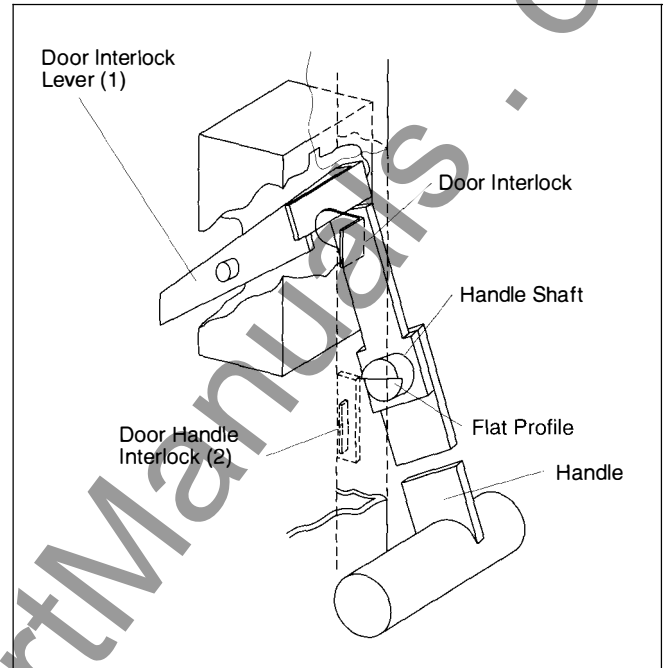

Figure 7. Door Interlock and Door-Handle Interlock.

The interlock may be defeated only by authorized and qualified personnel. Do not attempt to defeat the interlock unless all incoming power is disconnected, grounded, and locked-out.

The def eater can be reached by removing a plastic cap from the lower part of the handle housing, then by removing the Allen-head set screw. The racking handle must be rotated approximately 23 degrees from the fully upward (ON) position of the handle in order to align the Allen-head set screw with the access opening. When the Allen-head set screw is removed, the handle can then be moved to the OFF position allowing the door to be opened. Refer to **Figure 8**.

After the malfunction has been corrected, the controller should be restored to normal operation by reversing the procedure used to defeat the interlock.

Contactor Interlock

To prevent accidental insertion or withdrawal of the contactor when it is energized, an interlock lever moves to engage notches in the cam when the contactor is closed, thus preventing motion of the racking mechanism. The interlock used with type 97H3 contactors is directly actuated, and is illustrated in **Figures 11** and **12**. The type 96H contactors employ a cable actuated interlock, shown in **Figures 13** and **14**.

General Description

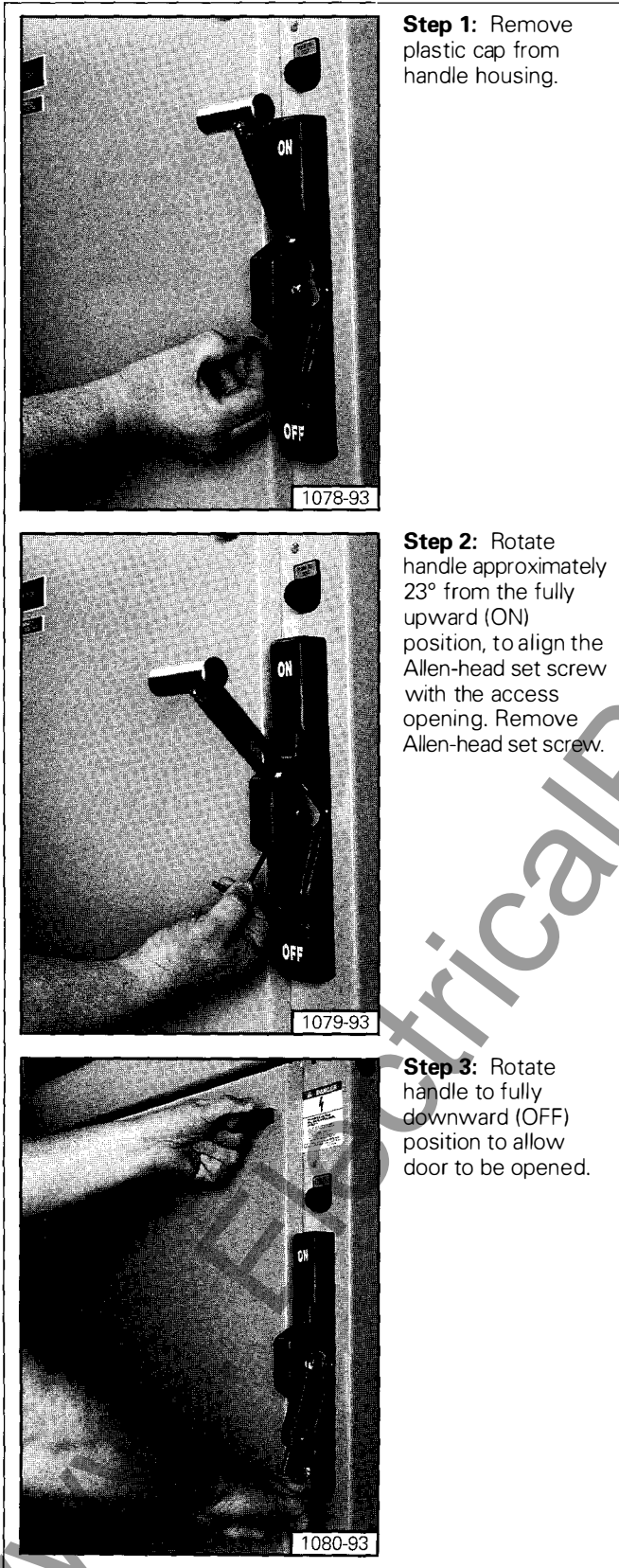

Figure 8. Procedure for defeating the door-handle interlock

	⚠ DANGER
	Hazardous voltages.
	Will cause death, serious personal injury, or equipment damage.

The door-handle interlock should be defeated only in the event of a malfunction in the racking mechanism.

Never defeat this interlock if the red contactor engagement light is on.

Test Switch

A test switch is provided to switch from run to test mode. The switch is located on the back side of the door, mounted on the low voltage compartment. See **Figure 9**. With the contactor racked out and the door opened, the test mode can be selected by rotating the switch to the test mode. With the switch in the test mode, the contactor can be electrically operated in its racked out position. Once the test has been completed, the contactor can be placed in operation by switching to the run mode, closing the door and racking in the contactor by operating the racking handle.

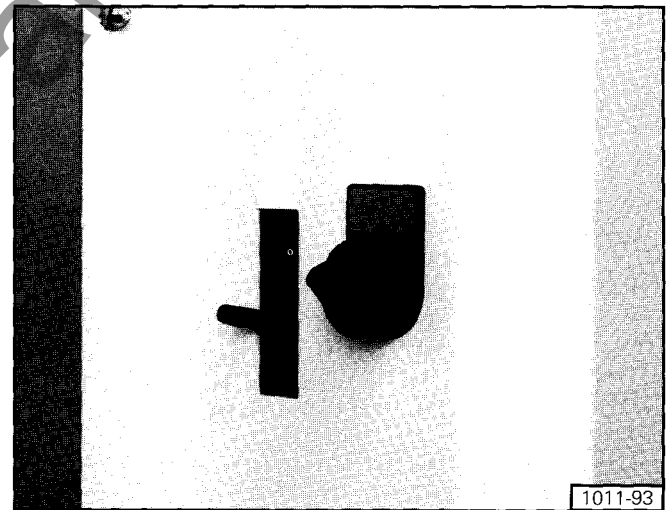

Figure 9. Run-Test Switch

Mechanical Latch

The mechanical latch is mounted on the left hand side of the guide plate and serves to locate and hold the contactor in the disengaged (test) position. The contactor is released by manually pivoting the latch assembly upward and rolling the contactor out of the enclosure. Refer to **Figure 6**.

Detent Lever

This lever is provided to prohibit relative motion between stab fingers and stab assembly. Slight initial force is required on the handle when moving it from the ON to the OFF position to free the driver link pin from the retaining slot in the detent lever. Refer to **Figures 11 and 12** (for type 97H3) or **Figures 13 and 14** (for type 96H)

General Description

Contactor Engagement Warning Light

A red warning light, mounted above the handle housing is energized only when the contactor is fully engaged (connected to the line and load stabs), and incoming power is present, independent of the condition (open or closed) of the contactor or the door. When the handle is moved to the OFF position, the red warning light should always go out, indicating the contactor is fully disengaged and isolated from the stab assembly. Refer to **Figure 10**.

If the handle is moved to OFF and the red light stays on, the racking mechanism is not operating properly and the contactor is engaged. **Do not attempt to open the high voltage door.** Disconnect and lockout all incoming power and refer to the "Troubleshooting" section.

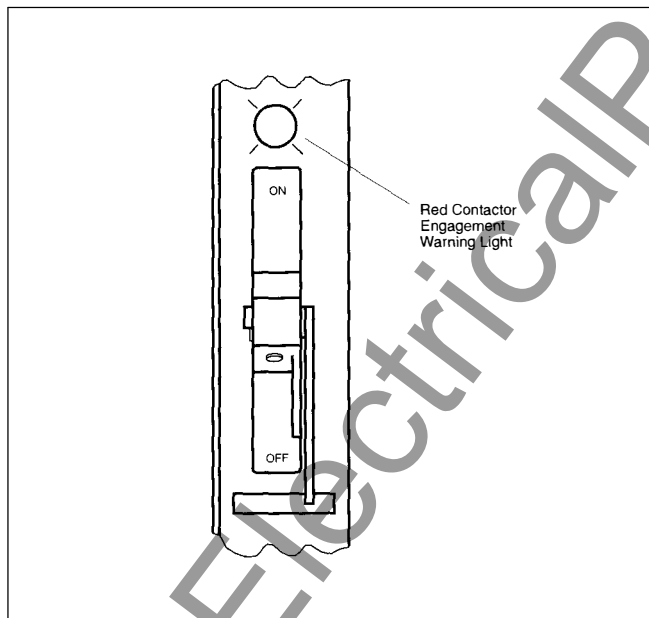
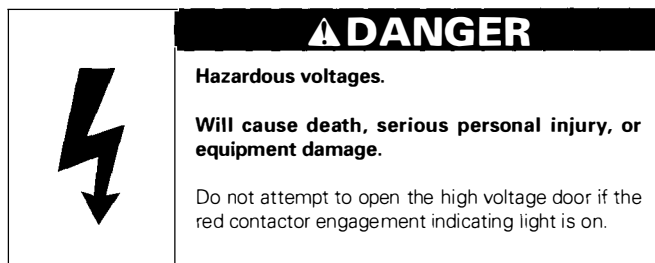

Figure 10. Contactor Engagement Warning Light

Line Switch Interlock (LSI)

All control power derived from the secondary of the control power transformer is carried from the contactor to the low voltage control panel through a set of contact fingers mounted on the rear of the contactor. Refer to **Figure 6**.

These contact fingers, along with the mating contact block which is stationary-mounted on the guide plate, make up the Line Switch Interlock (LSI).

The function of this interlock is to disconnect the load from the CPT secondary prior to disengagement of the main power stabs as the contactor is racked out.

Racking Switch Interlock (RSI)

The Racking Switch Interlock (RSI) is a microswitch mounted on the guide plate which functions to prevent operation of the contactor on the test power when it is in the engaged (ON) position. As the racking handle is moved from OFF to ON the normally closed RSI contact opens and isolates the test source from the control circuit. Refer to **Figure 6**.

General Description

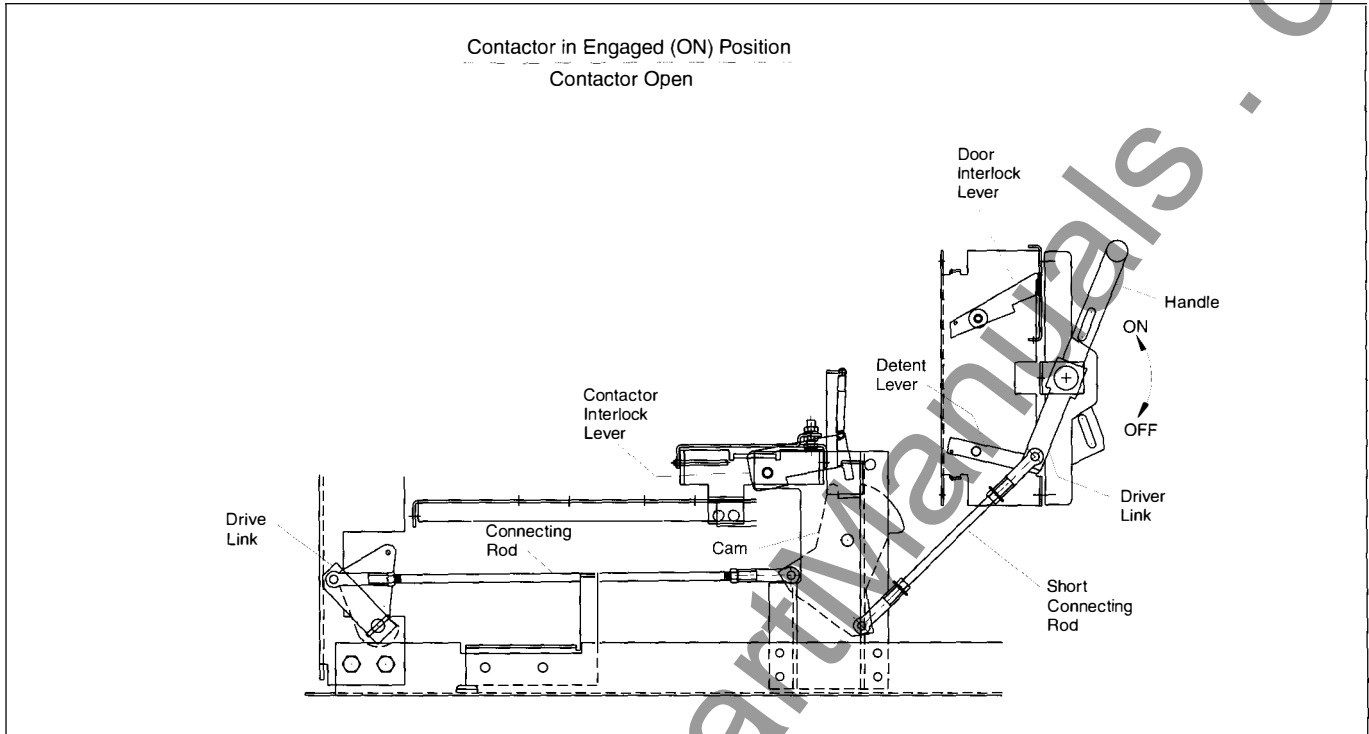

Figure 11. 97H3 Racking Mechanism - Handle in ON Position (Directly Actuated Interlock)

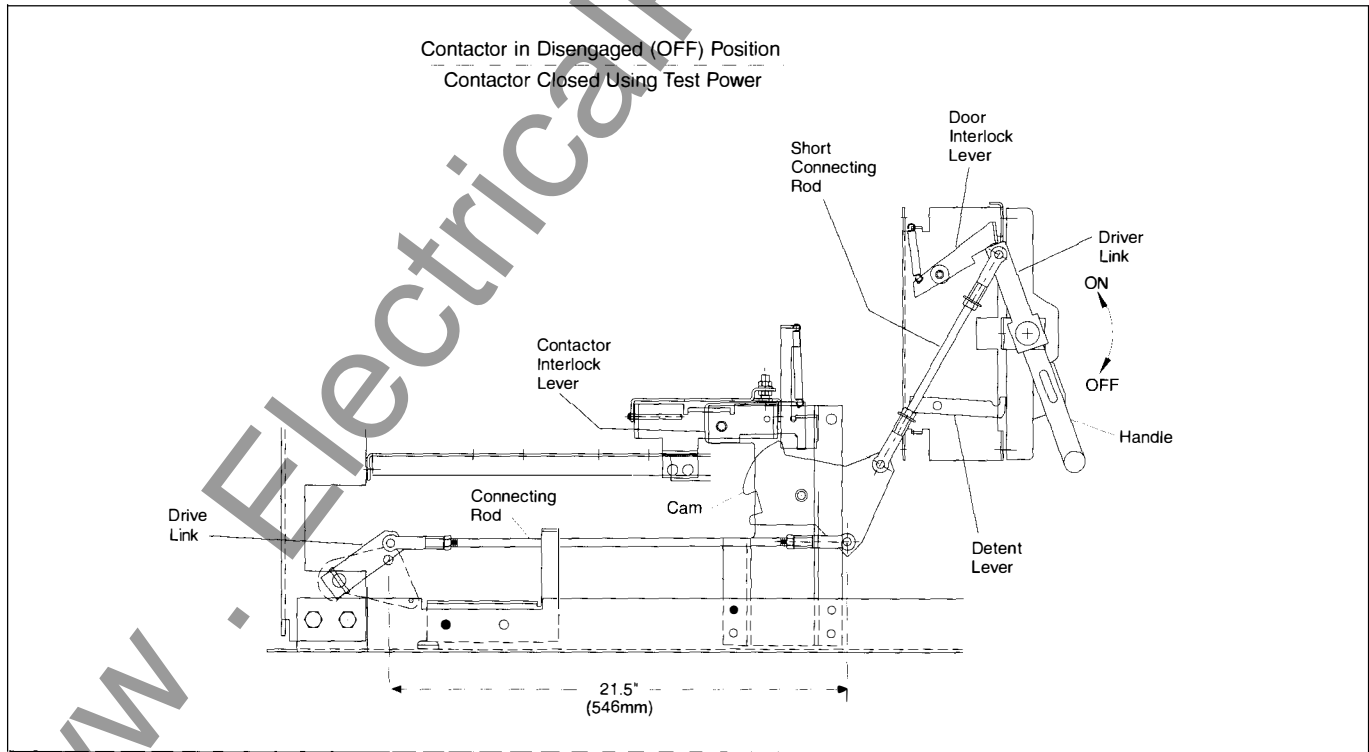

Figure 12. 97H3 Racking Mechanism - Handle in OFF Position (Directly Actuated Interlock)

General Description

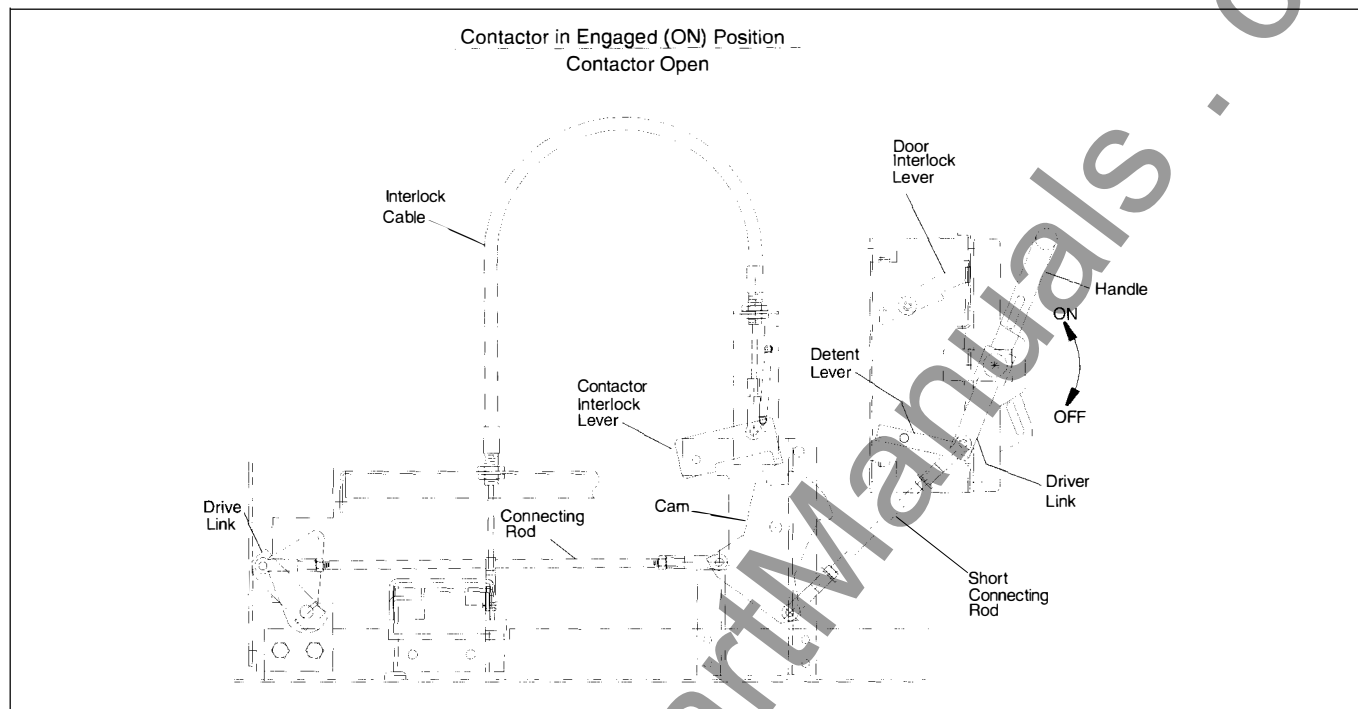

Figure 13. 96H Racking Mechanism - Handle in ON Position (Cable Actuated Interlock)

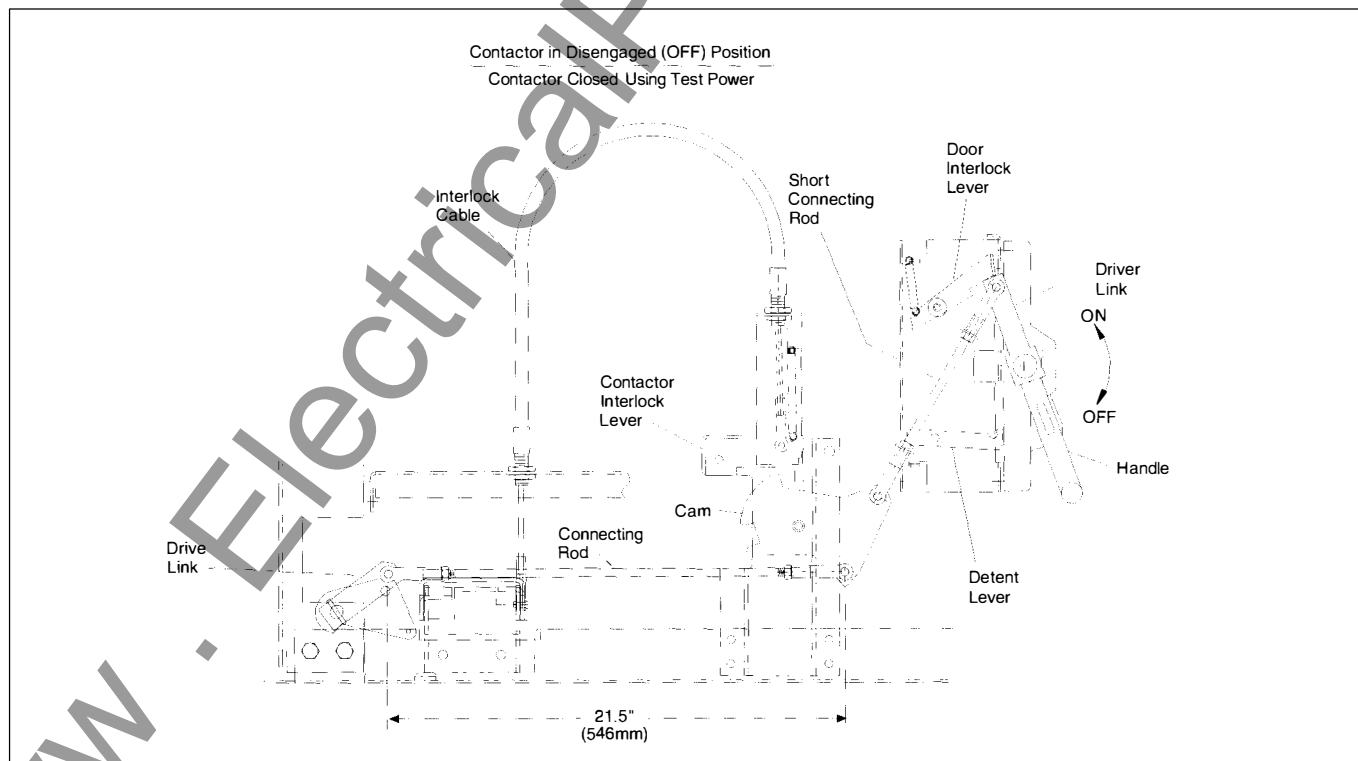

Figure 14. 96H Racking Mechanism - Handle in OFF Position (Cable Actuated Interlock)

General Description

Power Fuses (current-limiting)

ANSI "R" rated fuses Type FM are used for motor starting duty in 5kV Class E2 controllers. ANSI "R" rated fuses Type A720R are used for motor starting duty in 7.2kV Class E2 controllers. ANSI "E" rated fuses are used for most other applications.

Time-current characteristic curves and other fuse application information is shown in **Table 3** and **Figures 15a-19**.

Use of 96H3 or 97H3 Contactor in Other Cell Types

The types 96H3 and 97H3 contactors differ in the manner in which the interlocks are constructed and operate. Therefore, 96H3 and 97H3 contactors are not interchangeable with each other. Similarly, these contactors are not directly interchangeable with the earlier 90H3 contactors. Modifications necessary to allow use of a 96H3 or a 97H3 contactor in a 90H3, 93H3, or 94H3 cell are summarized in **Table 4**.

93H3 and 96H3 contactors are directly interchangeable.

94H3 and 97H3 contactors are directly interchangeable.

Table 3. Power Fuses

Maximum Design Voltage	Catalog Number	Current Designation	Continuous Current @40°C	Minimum Interrupting Rating	Interrupting Rating 50/60Hz
5080	48FM2R-4G	2R (1 barrel)	70	190	Single Phase 80kA rms Asymmetrical (210MVA @ 2.4kV) (415MVA @ 4.8kV)
	48FM3R-4G	3R	100	225	
	48FM4R-4G	4R	130	330	
	48FM6R-4G	6R	170	500	
	48FM9R-4G	9R	200	740	
	48FM12R-4G	12R	230	955	
	48FM18R-5G	18R (2 barrel)	390	1440	
48FM24R-5G	24R	450	1910		
7200	A072F1D0R0-2R	2R (1 barrel)	70	190	Single Phase 80kA rms Asymmetrical (620MVA @ 7.2kV)
	A072F1D0R0-3R	3R	100	225	
	A072F1D0R0-4R	4R	130	330	
	A072F1D0R0-6R	6R	170	500	
	A072F1D0R0-9R	9R	200	740	
	A072F1D0R0-12R	12R	230	955	
	A072B2DAR0-18R	18R (2 barrel)	390	1440	
A072B2DAR0-24R	24R	450	1910		

Table 4. Modification Matrix for Use of 96H3/97H3 Contactor in 90H3/93H3/94H3/96H3/97H3 Cells

Power Cell (Compartment) Type		Contactor Type	
		93H3 or 96H3	94H3 or 97H3
Power Cell (Compartment) Type	90H3	Cell modification kit 25-213-200-501 required. Mount per 25-154-488-424. Kit includes new interlock spring and replacement mechanical latch. Modified cell will allow use of either 90H3, 93H3, or 96H3 contactor.	Cell modification kit 25-154-555-805 required. Mount per 25-213-213-405. Kit includes replacement interlock parts. Modified cell will no longer allow use of 90H3 contactor.
	93H3 or 96H3	—	Cell modification kit 25-154-555-804 required. Mount per 25-213-213-404. Kit includes replacement interlock parts. Modified cell will no longer allow use of 93H3 contactor.
	94H3 or 97H3	Modification of contactor required. Remove cable interlock assembly from 93H3 or 96H3 contactor, and replace with new interlock lever to convert to 94H3/97H3 configuration. Cell interlock modification also required. Use modification kit 25-154-555-811, which includes parts needed for contactor as well as for cell. Mount per 25-213-213-411.	—

General Description

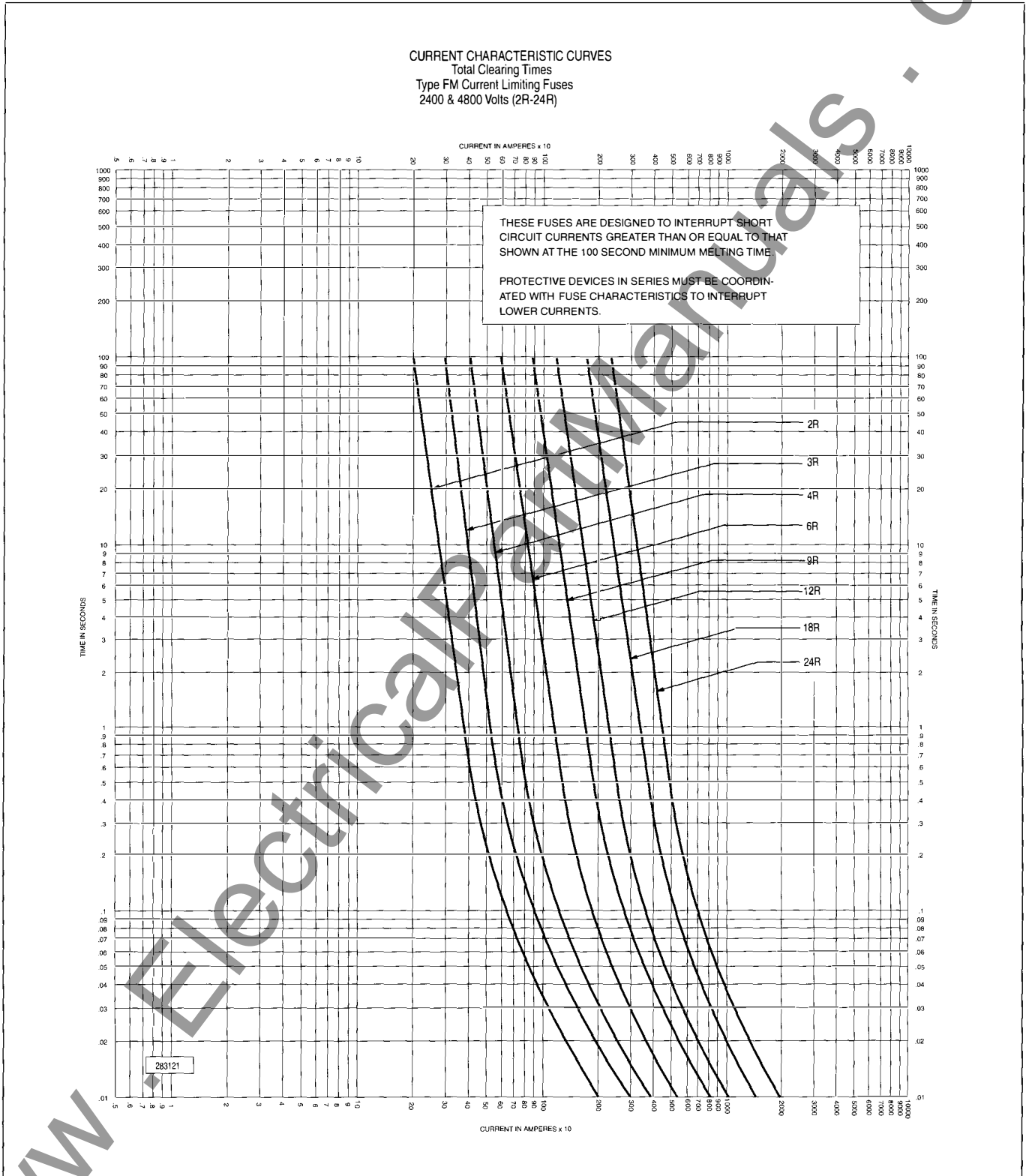

Figure 15a. Time-Current Characteristic Curves (Total Clearing Times)
Type FM Current Limiting Fuses 2400 & 4800 Volts (2R-24R)

General Description

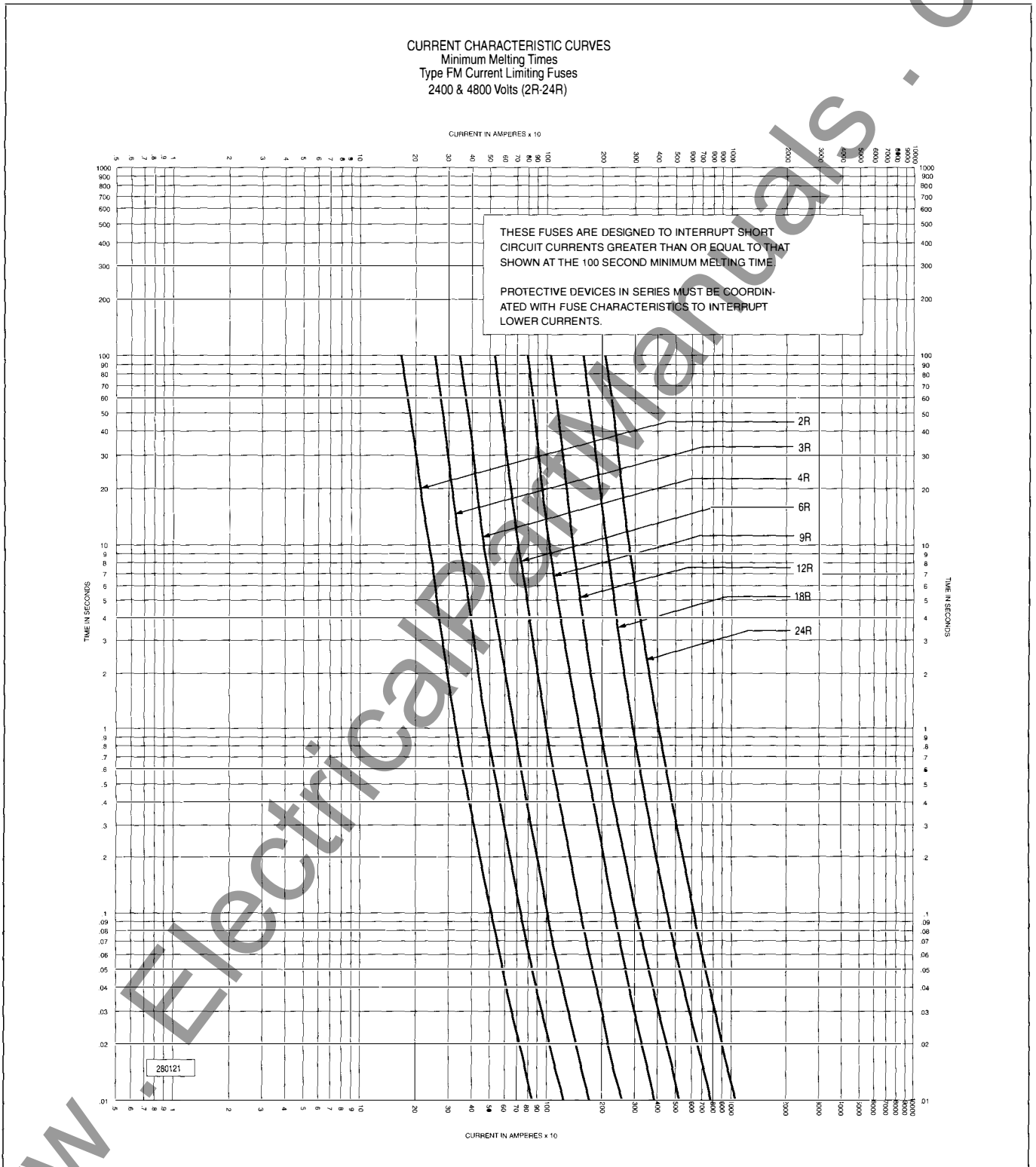

Figure 16a. Time-Current Characteristic Curves (Minimum Melting Times)
Type FM Current Limiting Fuses 2400 & 4800 Volts (2R-24R)

General Description

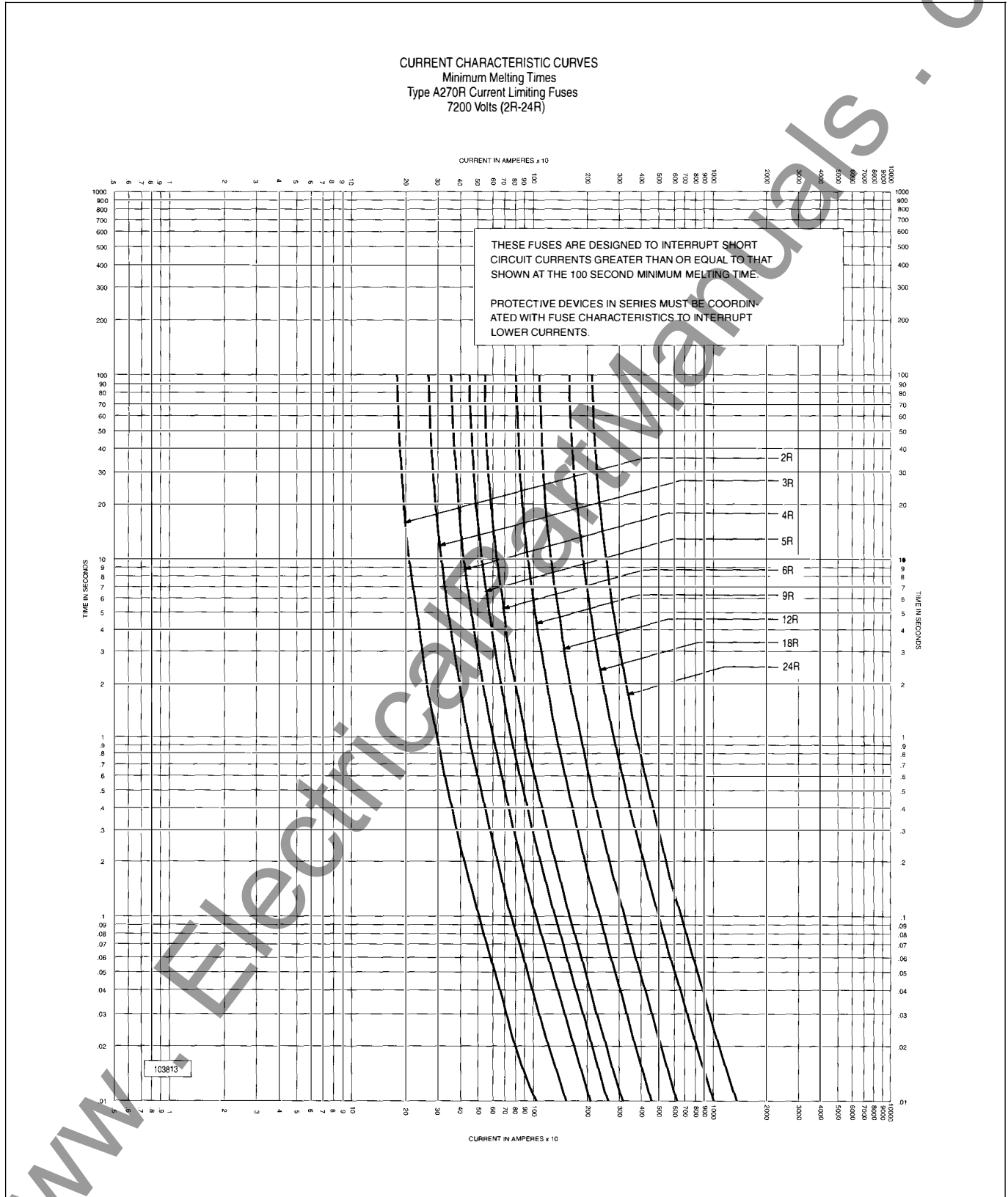

Figure 16b. Time-Current Characteristic Curves (Minimum Melting Times)
Type A720R Current Limiting Fuses 7200 Volts (2R-24R)

General Description

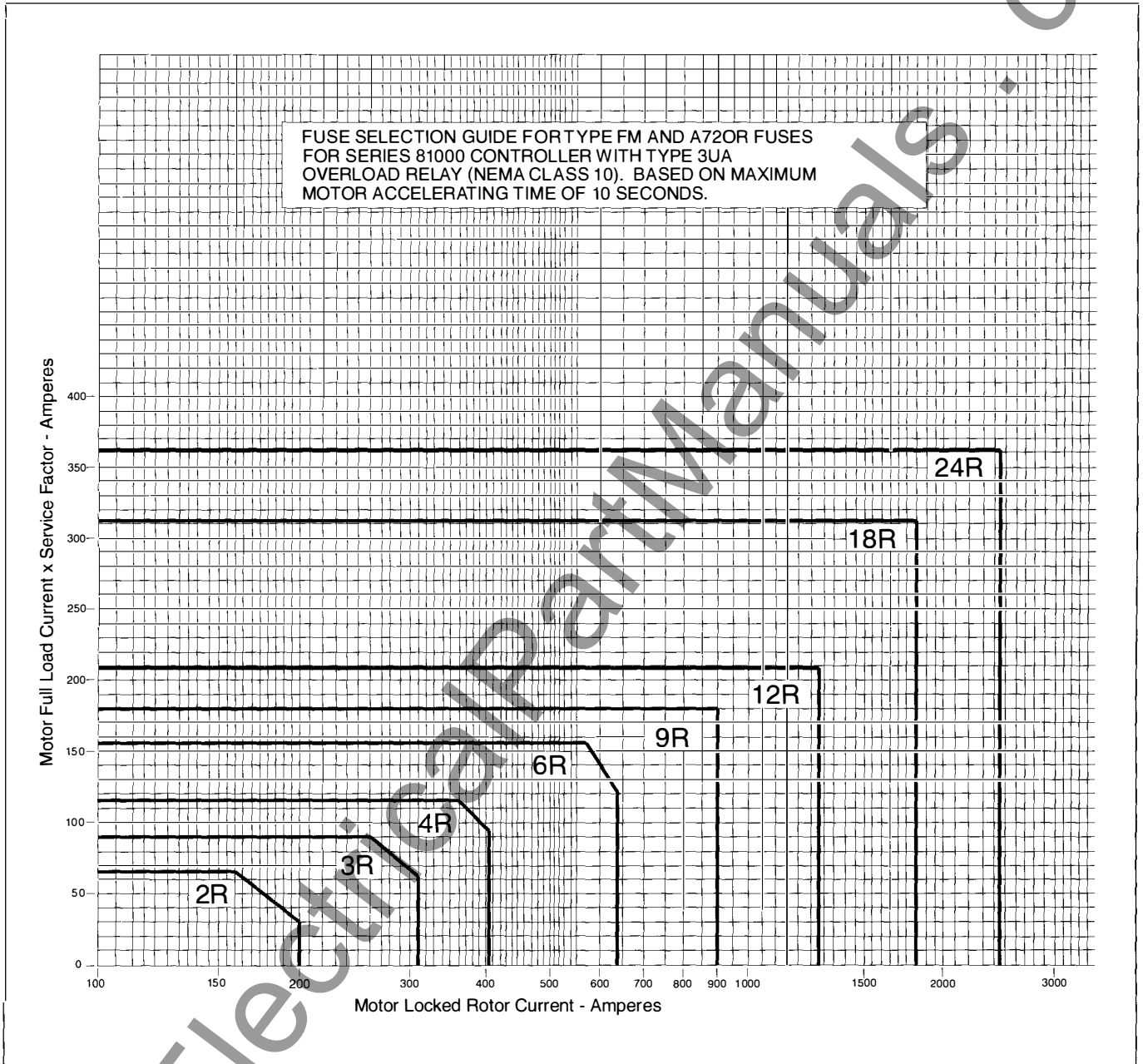

Figure 17. Fuse Selection Guide

General Description

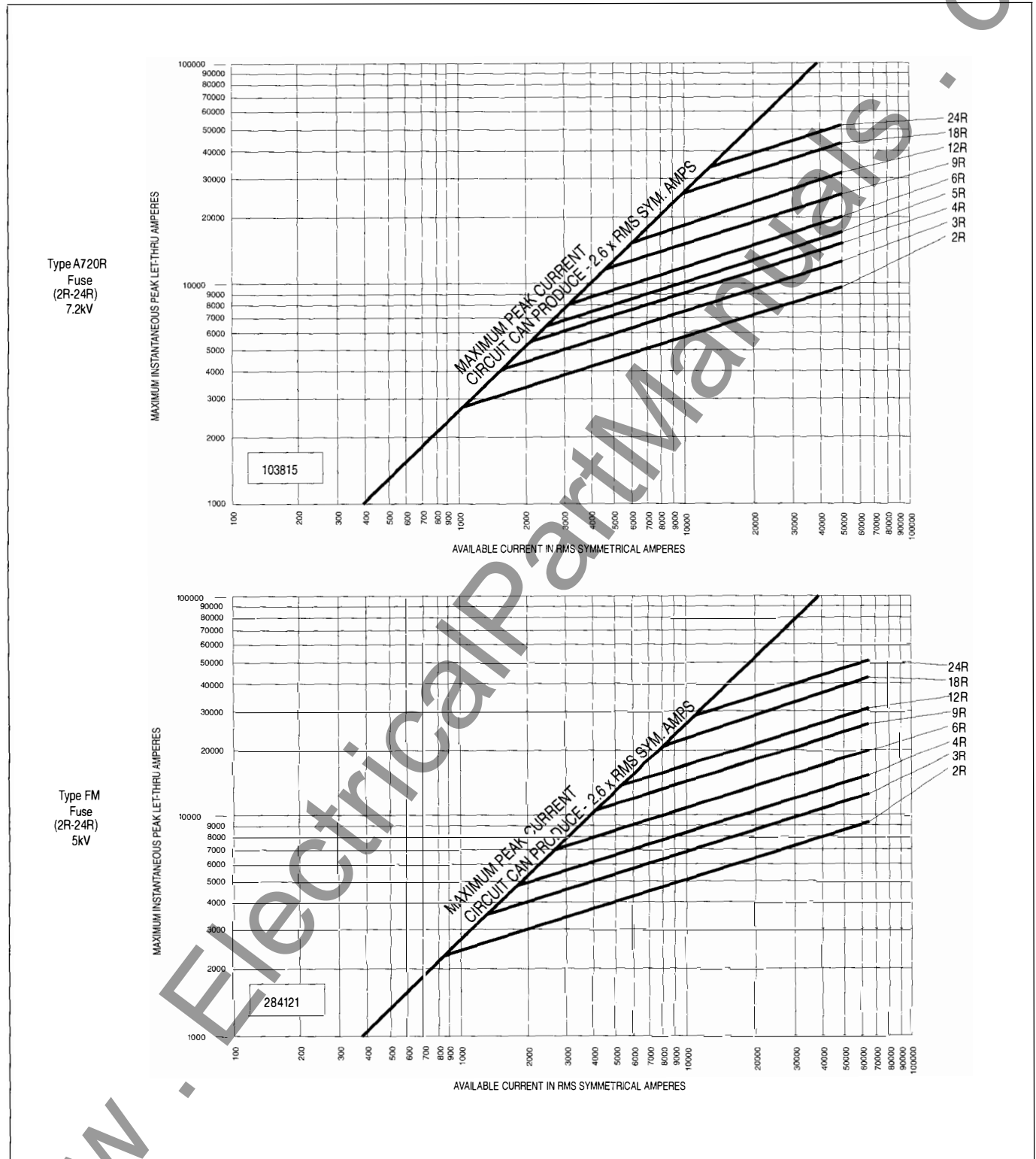

Figure 18. Current Limiting Characteristics of Type FM and Type A720R

General Description

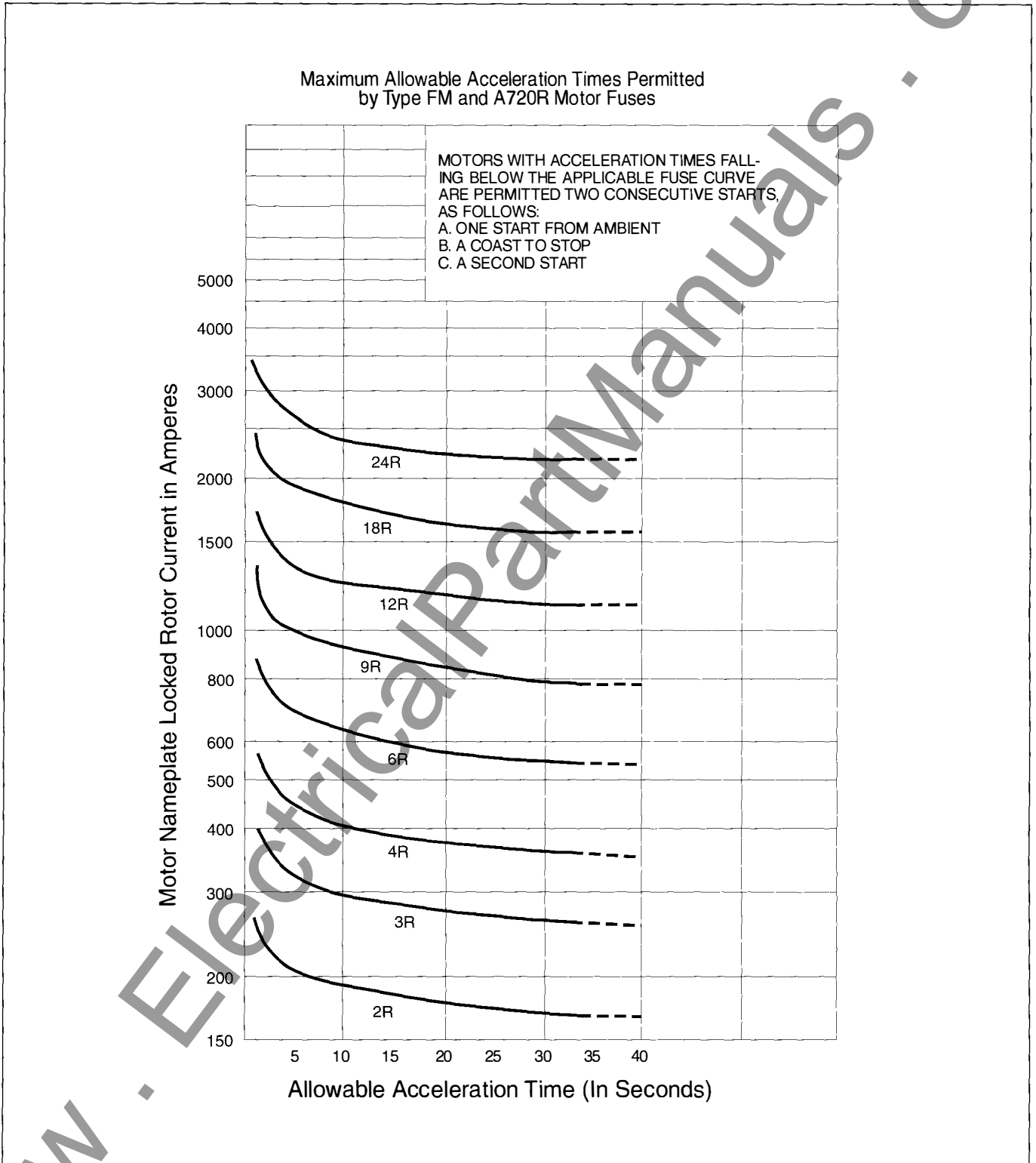

Figure 19. Maximum Allowable Acceleration Times

Receiving, Handling and Storage

Receiving

Upon receipt of this equipment, an immediate inspection should be made for any damage which may have occurred during shipment. The inspection should include examination of the packaging material and the contactor. Be sure to look for concealed damage and do not discard the packaging material. If damage is found, note damage on "Bill of Lading" prior to accepting receipt of the shipment, if possible.

NOTE: The way visible shipping damage is treated by the consignee prior to signing the delivery receipt can determine the outcome of the damage claim to be filed. Notification to the carrier within the 15 day limit on concealed damage is essential if loss resulting from unsettled claims is to be eliminated or minimized.

A claim should be immediately filed with the carrier, and the Siemens sales office should be notified if damage or loss is discovered. A description of the damage and as much identification information as possible should accompany the claim.

Handling

The Series 81000 controllers are shipped in groups of one to five vertical sections which are mounted on wooden shipping skids. For 90-inch high controllers, lifting angles are provided as shown in **Figures 20** and **21**.

Controllers with top mounted horizontal bus are provided with side mounted lifting angles, as shown in **Figure 22**.

The following precautions must be taken whenever moving a motor controller:

1. Handle the motor controller with care to avoid damage to components and to the frame or its finish.
2. Do not remove the wooden shipping skid until final installation position is reached.
3. Handle the motor controller in an upright position only. Motor controllers are normally front heavy, and frequently top heavy. Balance the load carefully and steady the motor controller, if necessary, during movement. Some motor controllers may contain heavy equipment, such as transformers or reactors, that can be adversely affected by tilting.
4. Know the capabilities of the moving means available to handle the weight of the motor controller. Adequate handling facilities should be available. Each vertical section, with contactors, weighs approximately 1500 lbs. If a vertical section contains power factor correction capacitors, reactors, or large transformers, sufficient additional weight handling capacity must be allowed.
5. It is recommended that a crane or hoist be used to handle the controller if at all possible. If a crane or hoist is not available, and other handling means are necessary, extreme care must be exercised to insure that the equipment is secured during the movement and placement operations to prevent tipping and falling. Jacks, prybars, dollies, roller lifts, and similar devices all require supplemental blocking beneath the motor controller, and restraints to prevent tipping. **These devices are not recommended due to the hazards implicit in their use.**

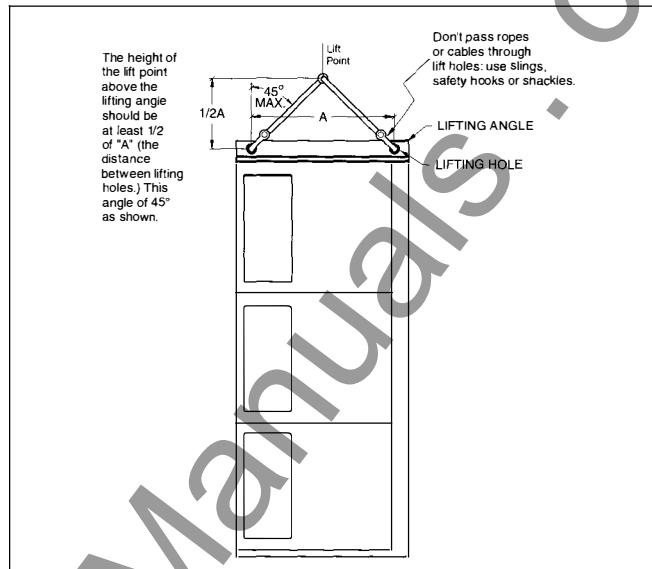

Figure 20. Lifting a single 90" high unit

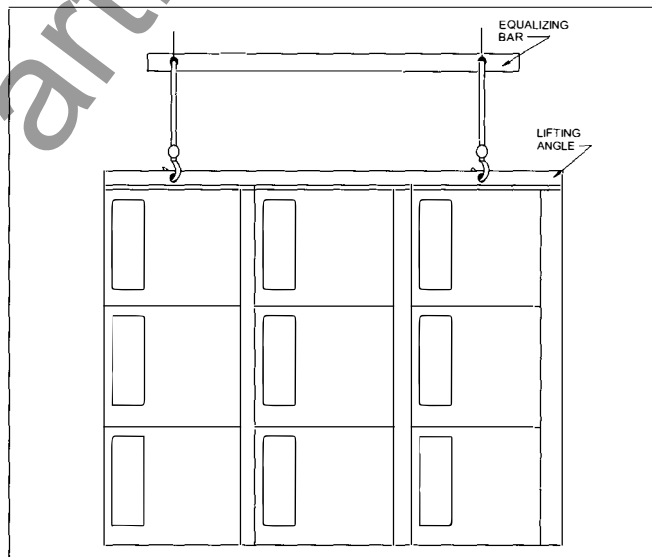

Figure 21. Lifting for 2 or 3 section group, 90" high units

The following precautions should be taken when moving the controller with a crane or hoist:

1. Select rigging lengths to compensate for any unequal weight distribution.
2. Do not allow the angle between the lifting cables and vertical to exceed 45°.
3. Do not pass ropes or cables through lifting brackets. Use only slings with safety hooks or shackles.
4. If overhead restrictions do not permit lifting by top mounted brackets, or angles, the controller may be underslung from the base. The sling load must be distributed evenly and padding or spreader bars must be used to avoid scarring and structural damage.
5. **Never lift the controller above an area where personnel are located.**

Receiving, Handling and Storage

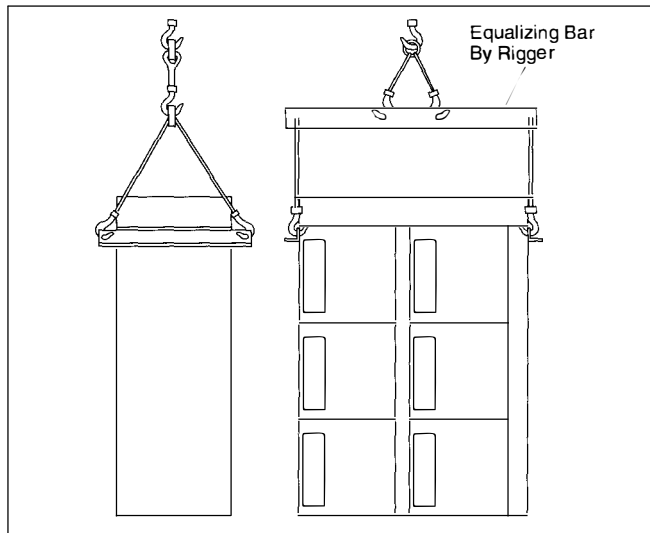



Figure 22. Lifting for units with top mounted bus

	⚠ WARNING
	Heavy equipment.
	Improper lifting can result in death, serious personal injury, or substantial property damage. Use extreme care when handling the motor controller.

The following precautions should be taken when moving the controller with a forklift:

1. Keep the controller in an upright position only.
2. Make sure the load is properly balanced on the forks.
3. Place protective material between the controller and forklift to prevent bending and scratching.
4. Securely strap the controller to the forklift to prevent shifting or tipping.
5. Excessive speeds and sudden starts, stops, and turns must be avoided when handling the controller.
6. Lift the controller only high enough to clear obstructions on the floor.
7. Take care to avoid collisions with structures, other equipment, or personnel when moving the controller.
8. **Never lift the controller above an area where personnel are located.**

The following precautions should be taken when moving the controller by rolling on pipes:

1. Keep the controller in an upright position.
2. Use enough people and restraining devices to prevent tipping.
3. The surface over which the controller is rolled must be level, clean, and free of obstructions. **Never roll a controller on an inclined surface.**
4. It should be recognized that rolling a controller is especially hazardous to fingers, hands, and feet and the controller is susceptible to tipping. Measures should be taken to eliminate these hazards.
5. All pipes must be the same outside diameter and should have no flat spots. Only steel pipe should be used for this purpose.

Skid Removal

Skid removal should be performed just prior to final placement of the controller and is achieved by removing the skid lag bolts. If

the lifting brackets or angles have been removed, reinstall them on the top of the controller (Refer to "Recommended Torque Values," **Table 10**) and attach the crane rigging to remove all slack without lifting the equipment. This is a recommended safety measure to reduce the possibility of tipping. The lag bolts may now be removed, the controller lifted, the skids removed, the controller lowered into place, and the anchor bolts secured. The last operation should be performed with adequate rigging tension to prevent tipping. After all additional shipping sections are secured in a similar manner, sections and bus bars should be joined in accordance with instructions in the installation section of this manual. Close doors as soon as possible to eliminate intrusion of dirt and foreign materials into the controller enclosure.

Contactors Removal

Controllers are normally shipped with the contactors installed and braced in their respective compartments. To facilitate handling of the contactors, it is recommended that they not be removed from their shipping positions until after the vertical section or group of vertical sections has been removed from the wooden shipping skid and set into final position. At this time, the contactors may be removed by unbolting the retaining bracket which secures the left front contactor wheel to the guide plate. Handle with care to avoid damaging LSI disconnect finger on rear of contactor, and latch mechanism on latched contactors.

NOTE: To avoid damage to the racking mechanism or other components, do not attempt to rack the contactor before the retaining bracket has been removed.

Storage

If the controller cannot be placed into service reasonably soon after its receipt, it must be stored in a clean, dry space where a uniform temperature prevents condensation. Preferably, it should be stored in a heated building, with adequate air circulation, and protected from dirt and water. Motor controllers should be stored where they are not subject to mechanical damage.

If the motor controller is to be stored for any length of time prior to installation, restore the packing for protection during that period. Where conditions permit, leave the packing intact until the motor controllers are at their final installation position. If the packing is removed, cover the top and openings of the equipment during the construction period to protect them against dust and debris.

Outdoor storage is not recommended. However, if an indoor motor controller must be stored outdoors, it should be securely covered for protection from weather conditions and dirt. Temporary electrical heating should be installed to prevent condensation; approximately 150 watts per section is adequate for the average motor controllers size and environment. All loose packing or flammable materials should be removed before energizing space heating equipment.

An unenergized outdoor motor controller should be kept dry internally by installing temporary heating (see above). If the unit has been provided with optional self-contained space heaters, these may be energized in lieu of installing temporary heating.

Any scratches or gouges suffered from shipping or handling should be touched up with a can of spray paint to prevent corrosion.

Installation

	⚠ DANGER
	Hazardous voltages.
	Will cause electric shock, burn or electrocution.

Disconnect, ground, and lockout incoming power and control voltage sources before beginning work on this or any other electrical equipment.

Installation should be performed only by qualified personnel.

Introduction

Before performing any installation activities:

- Test all power terminals to verify that incoming power has been disconnected. Use only approved high voltage test equipment to check voltage on power terminals. Do not attempt to measure high voltage (over 600 volts) with a volt-ohm meter.
- Check all control and secondary circuit terminals with a voltmeter to make certain that all sources of incoming control and secondary voltage have been disconnected.
- Connect safety grounds to power terminals after the system has been de-energized, and prior to working on the equipment.
- Perform all disconnecting, grounding, and lockout operations in accordance with established safety procedures.
- Follow the procedure outlined in the Pre-Energization Check section of this manual before power is restored.

Operating Environment

The Series 81000 controller conforms with the provisions of NEMA standard ICS1, clause 6, Altitude Class 2KM (class 1KM for 96H6 contactors - refer to Instruction Manual MVC-9098), which defines the usual service condition for electromagnetic control. It is designed for indoor use where the temperature inside the controller is higher than the ambient temperature. The controller is capable of carrying its rated load when the ambient temperature does not exceed 40°C (104°F) and the altitude does not exceed 6600 feet (2000m) (3300 feet (1000m) for 96H6 contactors) above sea level. Where unusual service conditions exist, or where temperature or altitude limitations are exceeded, the controller construction, ratings, or protection may require alteration. Some examples of unusual service conditions are excessive moisture, vibration, or dust.

Site Preparation and Mounting

Installation shall be in accordance with the National Electrical Code, ANSI, and NFPA 70 Standards. Unless the controller has been designed for unusual service conditions, it should not be located where it will be exposed to ambient temperatures above 40°C (104°F), corrosive or explosive fumes, dust, vapors, dripping or standing water, abnormal vibration, shock, tilting, or other unusual operating conditions.

The controller should be installed in a clean, dry, heated place with good ventilation. It should be readily accessible for cleaning and inspection and should be carefully set up and leveled on its supporting foundation and secured in place. Supporting surfaces for the controller at each anchor bolt must be level and in the same plane within 0.06" (1.6mm). There must not be any projection above this plane within the area covered by the controller structures. If the mounting site does not meet

these conditions, the controller must be shimmed where necessary to prevent distortion of the frame.

The controller can be mounted by many different fastening systems including true drop in, cast in place, power actuated, or threaded insert fasteners. See **Figures 23** and **24** for anchor bolt locations. The bolt pattern is dependent on frame width and depth, location in the lineup, and whether or not sill channels are furnished. The group arrangement drawing for each controller details the anchor bolt locations. The coordination between the bolts and the controller should be verified prior to attempting installation. Expandable inserts in pre-drilled holes or imbedded "L" bolts are recommended. Wooden plugs driven into holes in masonry or concrete are not recommended for anchoring inserts and should never be used. The bolt size must be 1/2".

Welding the steel base or sill channels to a steel floor plate is an alternate mounting method especially recommended in areas subject to seismic (earthquake) activity.

Grouting the sill channels (refer to **Figure 25**) is another method of fastening the controller to the foundation. This method requires the foundation to be grooved to accept the sill channels. The actual groove dimensions must be coordinated with the floor plan layout on the group arrangement drawing included in the controller information packet.

General Pre-Installation Inspection

1. Check all parts for secure mounting and good electrical connections. Inspect visually for overall good condition.
2. Inspect frame for dents and other damage. Swing doors to make sure they pivot easily.
3. Operate the racking mechanism to insure free and smooth operation. Inspect the stab assembly and shutter mechanism.
4. Check fuses for sure fit in clips. Check fuse clips for deformities and secure mounting.
5. Check control circuit plug and receptacles for bent pins and other damage.
6. Make sure that cable clamps and insulators are in good condition.

Grounding

The frame of each controller must be grounded. This connection must be made before making power connections. If a ground bus is furnished, the ground connection should be made to the ground bus. The control and instrumentation circuits are grounded to the enclosure. This connection can be temporarily removed for test purposes, but it must be reconnected before the controller is returned to operation. If ground bus is not furnished, ground connection should be made to the mounting bolt for the motor cable ground lug provided next to the T1, T2, and T3 connections.

Electrical Connection

To simplify line and load cable connections, the drawout contactor carriages should be removed. Be sure to disconnect the control plug before attempting to remove the contactor.

Line connections should be made first. See **Figures 27-30** for details.

Installation

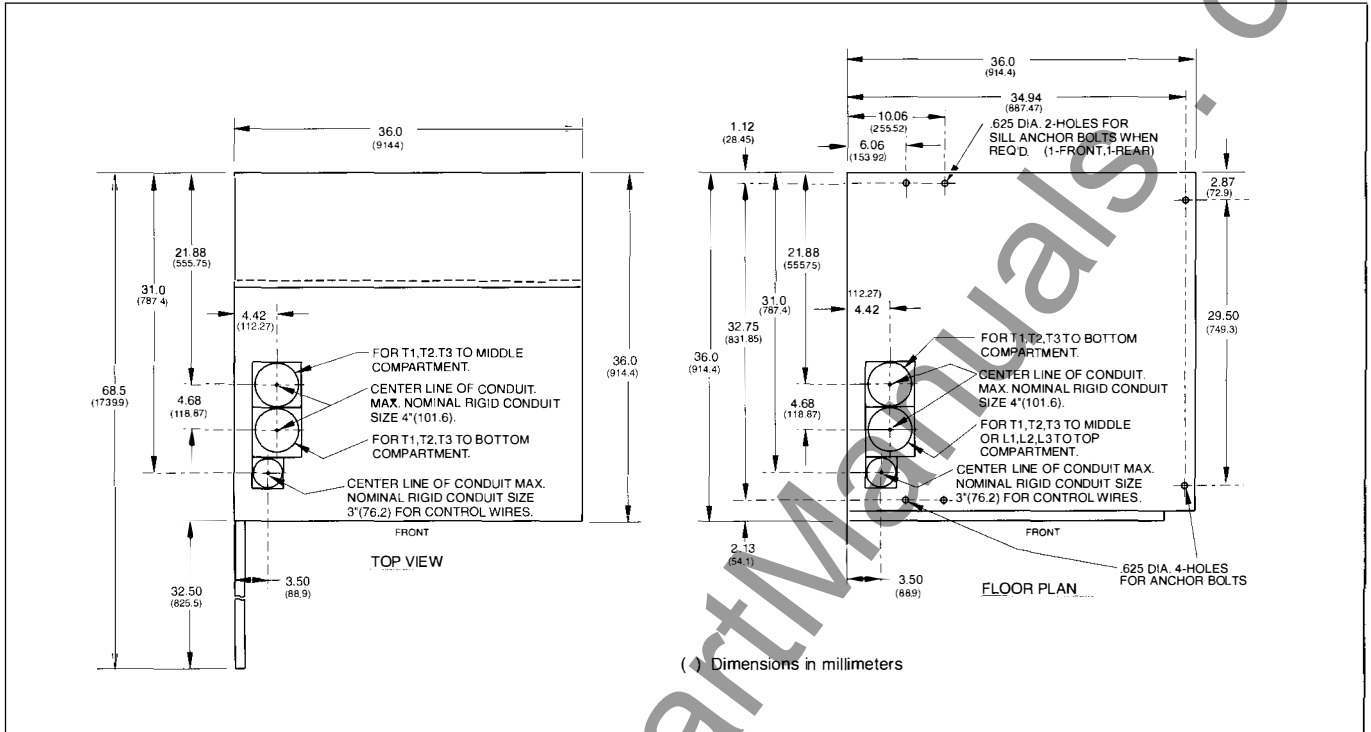

Figure 23. Top View and Typical Floor Plan with Bus Located in Top Compartment

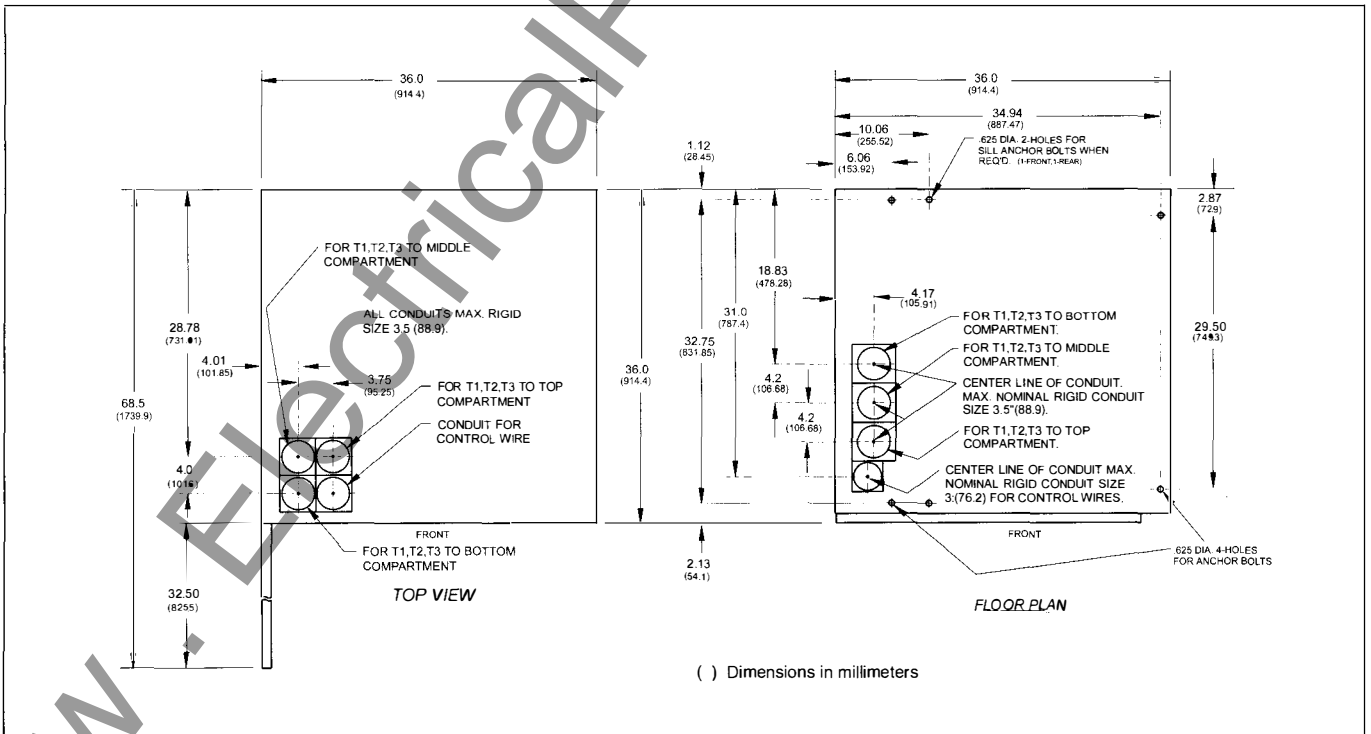

Figure 24. Top View and Typical Floor Plan with Bus Located in Top Hat Compartment

Installation

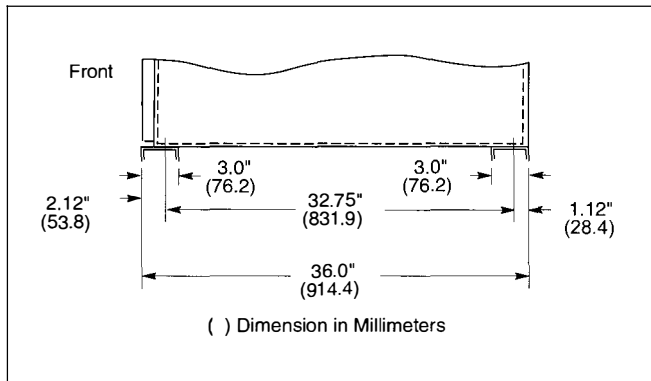

Figure 25. Typical Side View with Optional Sill Channels

Load terminals are connected directly to the current transformers (if bar or wound type) or to the terminals adjacent to the current transformers located on the left side of the starter unit. Vertical conduits are provided for top or bottom load cable isolation. See **Figure 26**. Typical conduit space for top or bottom entry of load cables and control wires is given in **Figures 23** and **24**.

Contactor Installation

Preinstallation Checks

Correct installation of contactors is essential to proper controller operation. Before installing a contactor in any medium voltage compartment, observe the following check list:

1. Check to see that the catalog number, part number and power fuse rating given on the contactor rating label matches the information given on the medium voltage compartment rating label.
2. Check the following items in the contactor for agreement with the information given on the rating label:
 - a. Contactor type.
 - b. Contactor continuous ampere rating.
 - c. Power fuse type, "R" or "E" rating and voltage.
 - d. Control transformer primary fuse "E" rating and voltage.

⚠ WARNING

Hazard of explosion or fire.

Can cause serious personal injury, burn, or equipment damage.

Before installing contactor in any compartment, verify agreement between each of the following compartment label data and the corresponding data on the contactor label:

- Catalog No.
- Part No.
- Contactor Amp Rating
- Power Fuse Type
- Power Fuse Rating

Installation

After it has been verified that the correct contactor has been selected for a given medium voltage compartment, the contactor may be installed as follows:

1. Open the medium voltage compartment door (handle must be in OFF position, red contactor engagement light must be off).
2. Position the contactor in front of the compartment and align the rear contactor wheels with the inside edge of the guide plate sides.

NOTE: A lifting device or service dolly is required to install contactors in middle or upper compartments of two- or three-high designs.

3. Roll the contactor onto the guide plate and into the compartment until it stops. Use the handle on the front of the contactor for this purpose. When the contactor is fully inserted, the mechanical latch (see **Figure 6**) should rotate to prevent it from rolling back out of the compartment.
4. Connect the control wiring harness to the contactor by inserting the harness plug into the receptacle on the left side of the contactor.
5. Close and latch the medium voltage compartment door.

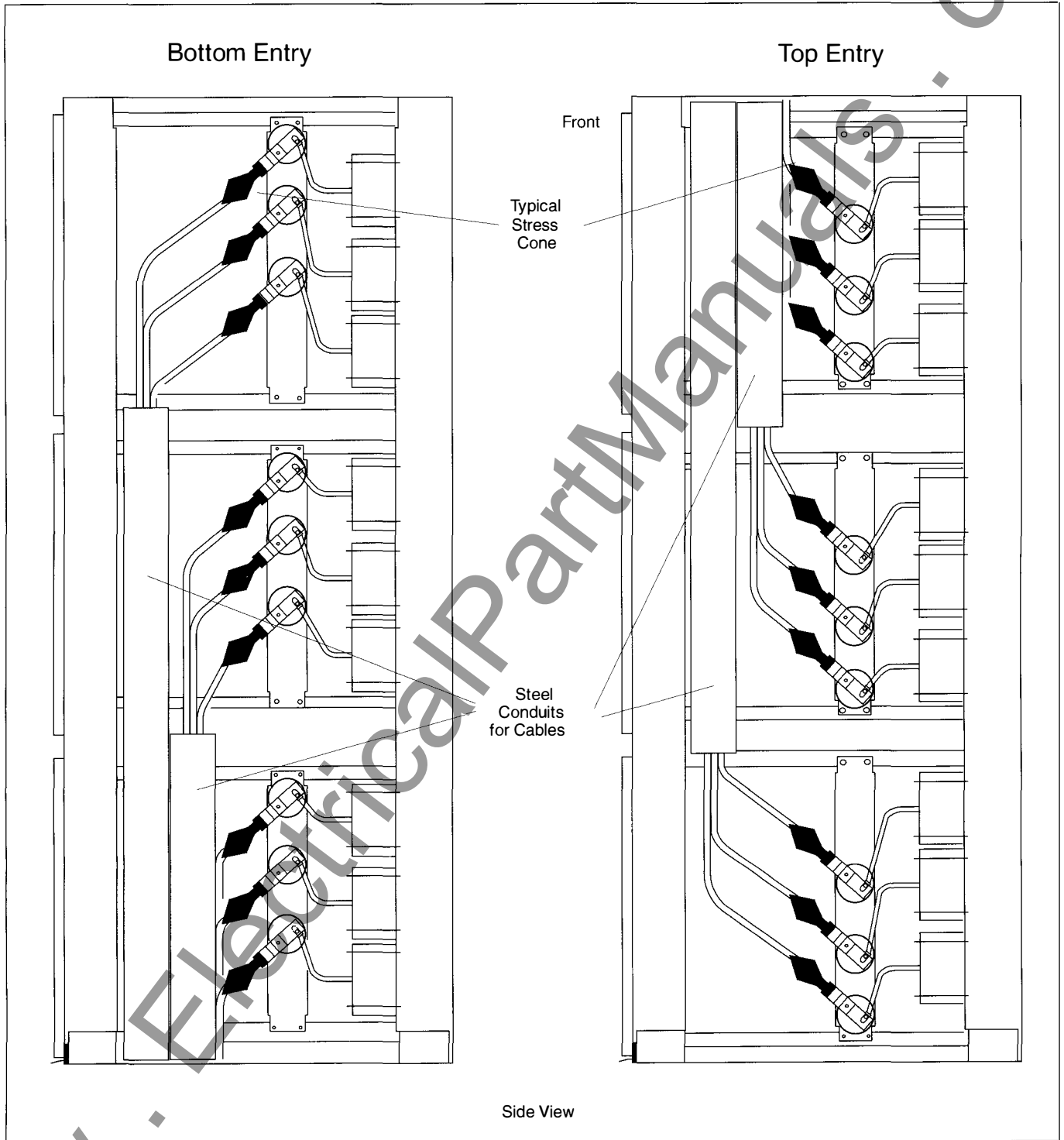

Figure 26. Load Cable Termination

Installation

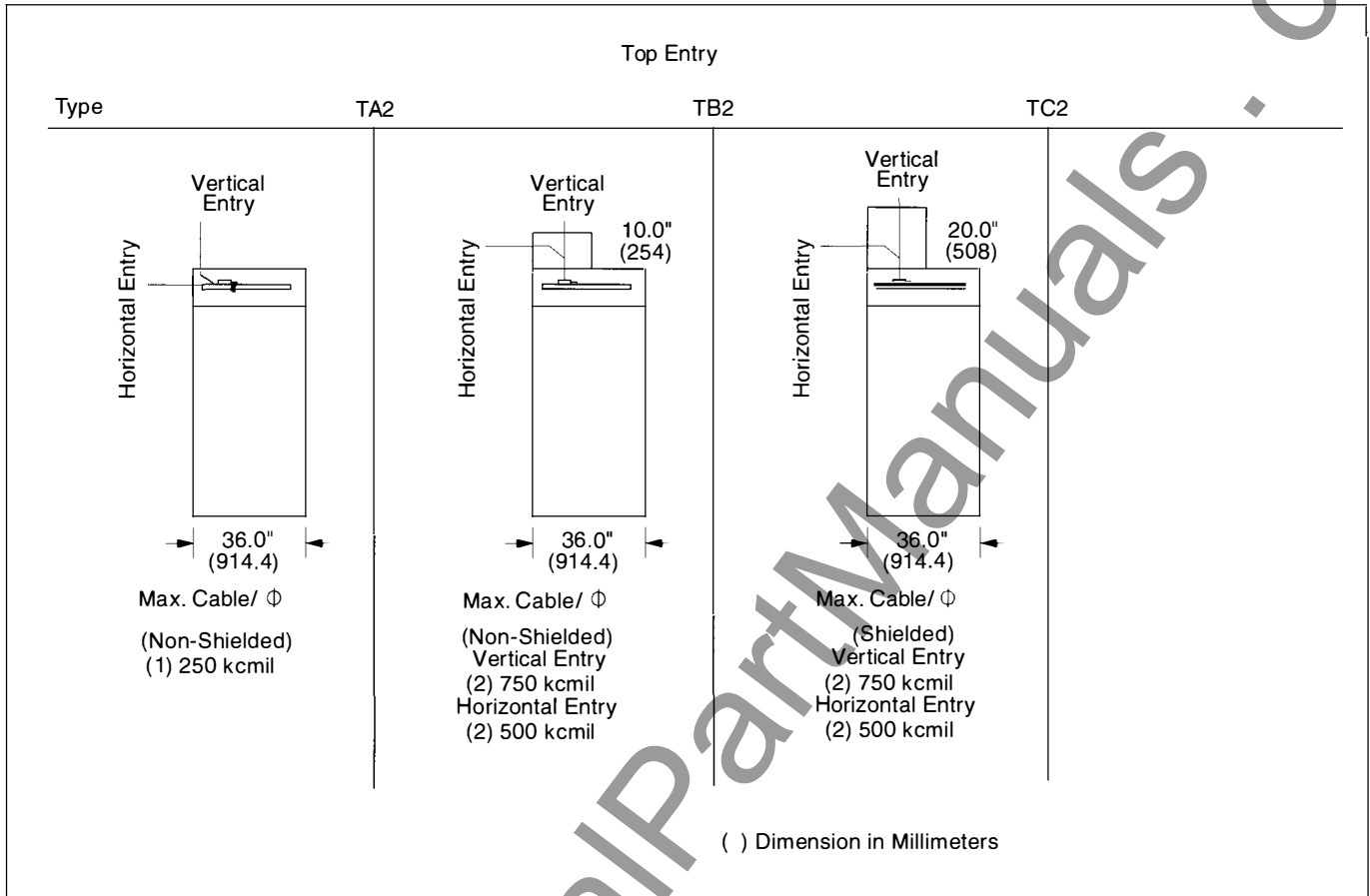

Figure 27. Incoming Line Arrangement with Bus Located on Top of the Cubicle - Top Entry

Installation

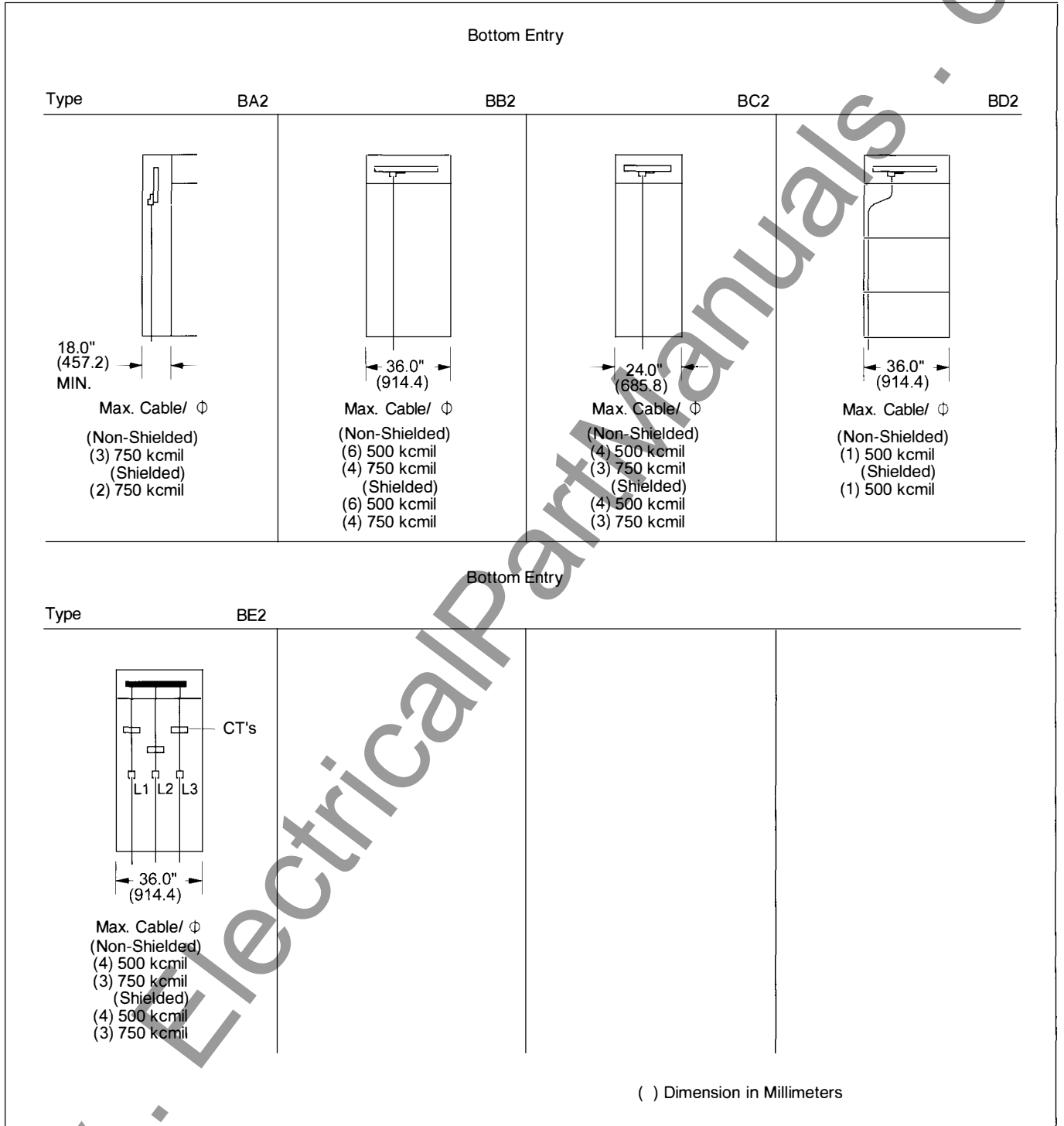

Figure 28. Incoming Line Arrangement with Bus Located on Top of the Cubicle - Bottom Entry

Installation

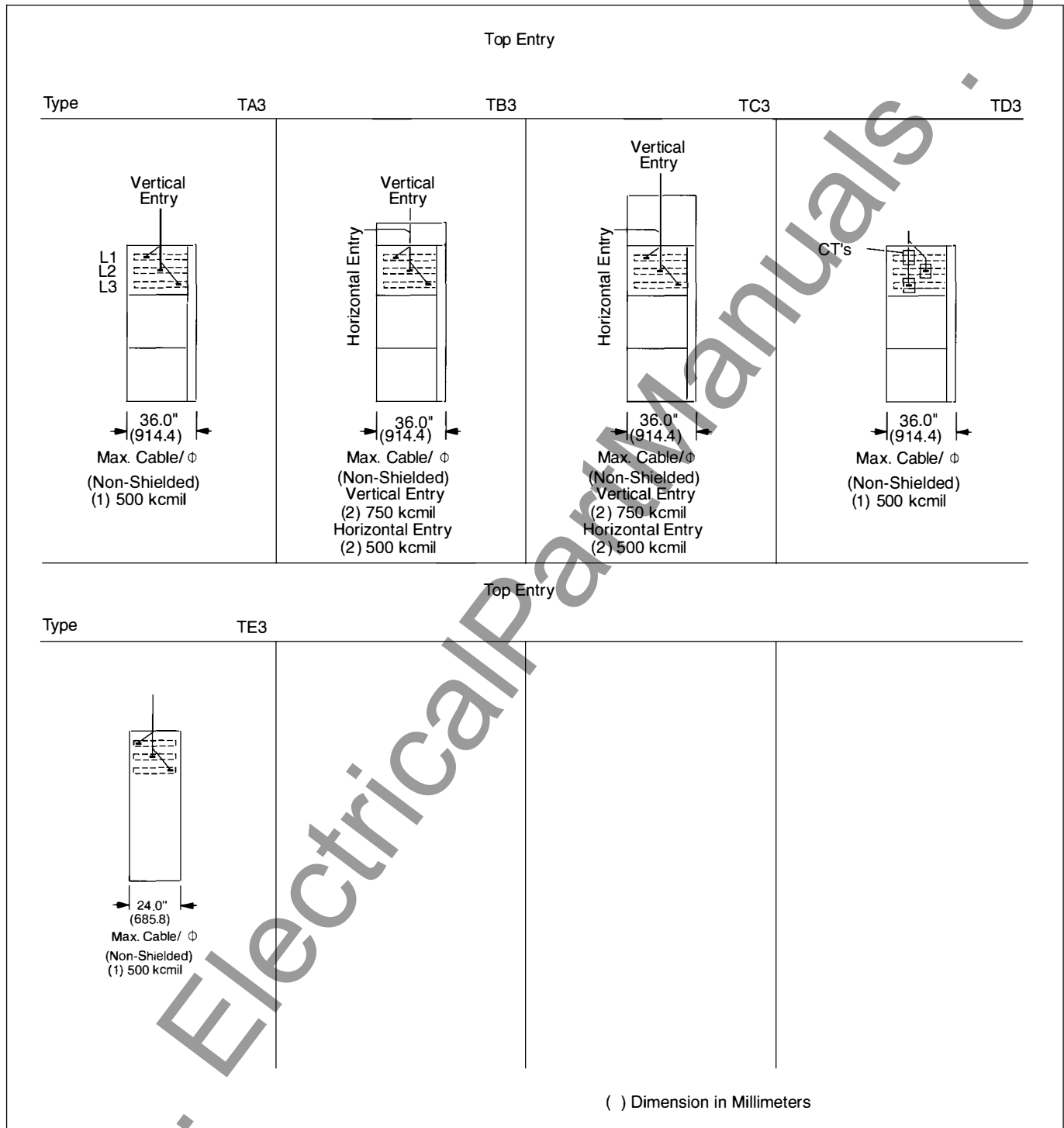

Figure 29. Incoming Line Arrangement with Bus Located in Rear of Upper Compartment - Top Entry

Installation

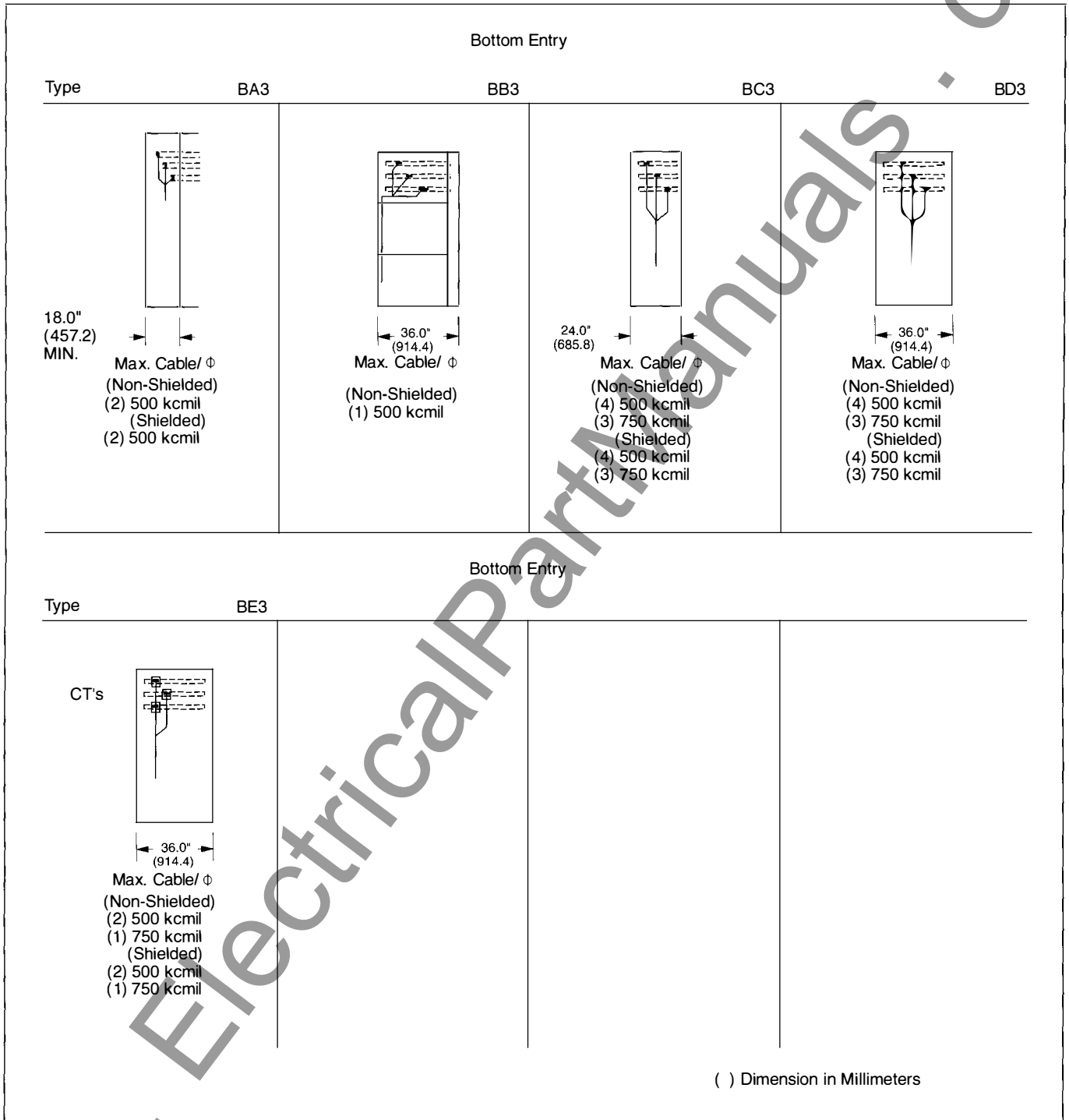

Figure 30. Incoming Line Arrangement with Bus Located in Rear of Upper Compartment - Bottom Entry

Installation

Power Cable Termination

Any termination for an insulated power cable must provide certain basic electrical and mechanical functions. These essential requirements include the following:

1. Connect the insulated cable conductor to electric equipment, bus, or uninsulated conductor to provide a current path.
2. Physically protect and support the end of the cable conductor, insulation, shielding system, and overall jacket, sheath, or armor of the cable.
3. Effectively control electrical gradients to provide both an internal and external dielectric strength to meet desired insulation levels for the cable system.

Series 81000 Controllers

The following general recommendations are offered for proper cable termination in the Series 81000 controllers.

1. Position the cables for maximum clearance between phases, ground, and other cable wire runs.
2. Avoid any possible contact between low voltage wires and medium voltage cables.
3. Prepare cable terminations in accordance with the cable manufacturer's instructions.
4. If contact between the cable and adjacent bus cannot be avoided, tape the bus to approximately 5/32" (4mm) thickness in the immediate vicinity of the cable contact point so that the surface creepage distance from the cable to the bare bus bar is at least 3.5" (89mm).

Termination of Lead-Covered Cable

Potheads are required to terminate lead-covered cables. A pothead is a hermetically sealed device used to enclose and protect cable ends. It consists of a metallic body with one or more porcelain insulators. Follow the pothead manufacturer's instructions to terminate the cable at the pothead. In general, the body is arranged to accept a variety of optional cable entrance sealing fittings, while the porcelains, in turn, are designed to accommodate a number of optional cable conductor and aerial connections.

Termination of Shielded Cables

In order to reduce and control the longitudinal and radial electrical stresses at the termination of the cable end to values within safe working limits of the materials used to make up the terminations, the most common method is to gradually increase the total thickness of insulation at the termination by adding insulating tapes, or a preformed insulating component, in the form of a cone. The cable shield is carried up the cone surface and terminated at a point near the largest diameter of the cone. This construction is commonly referred to as a stress cone and is illustrated in **Figure 31**.

NOTE: Consult individual cable supplier for recommended installation procedures and materials.

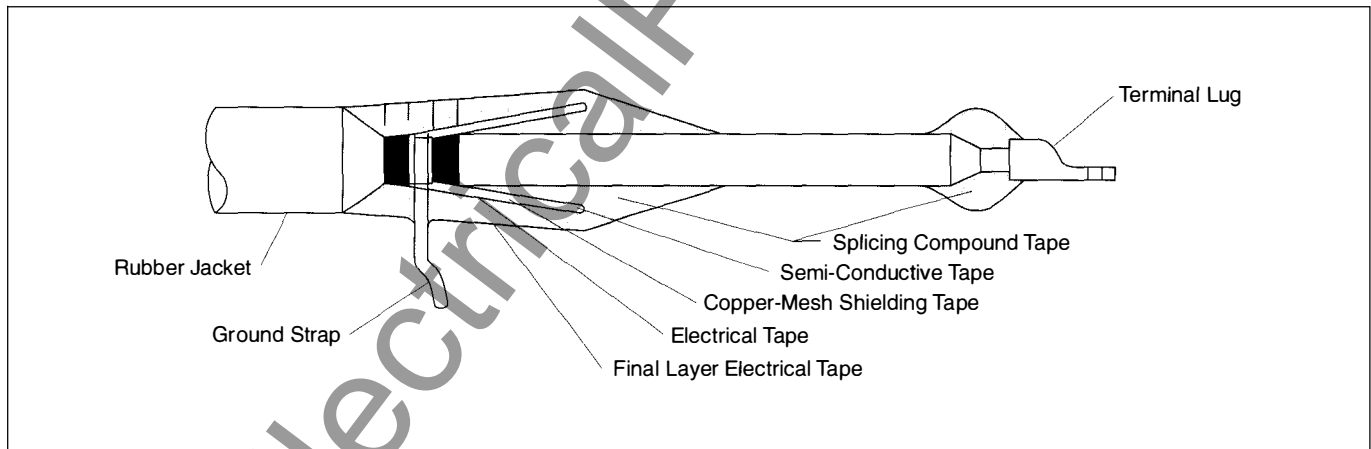

Figure 31. Typical Stress Cone

Siemens Advanced Motor Master System (SAMMS-MV™)

SAMMS-MV System Description

Siemens Series 81000 Medium Voltage Controllers are available with the SAMMS-MV system, the Siemens Advanced Motor Master System, specifically designed to meet the protection needs of medium voltage machines. The SAMMS-MV unit is a microprocessor-based software-configurable control and protection device for motor control applications. It provides all control logic and motor protection functions required for typical motor applications. The SAMMS™ system eliminates the need for separate overload relays, timers, control relays, meters, auxiliary contacts, pushbuttons, and pilot lights, simplifying wiring, panel layout, and selection.

Configuration

Controllers using the SAMMS-MV system are provided with current transformers and the SAMMS-MV unit. A hand-held communicator (HHC) is used to set parameters and display data. The SAMMS unit is powered from the control power transformer on the contactor. The device is mounted in the low voltage compartment for each starter, and provides all pushbutton and indicator functions.

Protective Functions

- Overload protection (with $\pm 5\%$ accuracy)
- Choice of 22 overload protection curves
- Phase loss/phase unbalance protection
- Impending overload trip alarm (option)
- Lockout on thermal overload trip
- Undercurrent/loss of load protection (option)
- Mechanical jam protection (option)
- Process current (load current) alarm (option)

The SAMMS system employs programmable control logic, with a design based on a standard hardware and electronic circuit configuration (ladder) logic. The control schemes may be modified by programming the controller's microprocessor. Traditional discrete motor control devices, such as timers, control relays, pushbuttons, and selector switches, are replaced by SAMMS-MV software and the pushbuttons and indicators on the unit control panel.

Starter Types

The SAMMS software library of more than 40 ladder diagrams covers most standard motor control applications. Starter types include:

- Across-the-line, non-reversing
- Across-the-line, reversing
- Two-speed, two-winding
- Two-speed, one-winding, constant or variable torque
- Two-speed, one-winding, constant horsepower
- Reduced-voltage, autotransformer or reactor

Table 5 lists the standard circuits.

For special motor control applications not covered by the library of standard ladder diagrams, custom diagrams can be constructed using the SAMMS-MVX input and output devices and their associated symbols. Siemens offers a software package for use on a personal computer to develop such custom diagrams.

Table 5. Standard Circuits for Starter Applications

Control Type	Starter Type						
	FVNR	FVR	2 Speed 2 Winding	2 Speed 1 Winding Constant or Variable Torque	2 Speed 1 Winding Constant HP	Autotransformer RVA	Reactor RVA
Local 2-Wire	✓	✓	✓	✓	✓	✓	✓
Local 3-Wire	✓	✓	✓	✓	✓	✓	✓
Local 3-Wire/Remote 2-Wire	✓	✓	✓	✓	✓	✓	✓
Local/Remote 2-Wire	✓	✓	✓	✓	✓	✓	✓
Local/Remote 3-Wire	✓	✓	✓	✓	✓	✓	✓
Local/Remote 3-Wire Electrically Interlocked	—	✓	—	—	—	—	—
Remote 2-Wire	✓	✓	✓	✓	✓	✓	✓
Remote 3-Wire	✓	✓	✓	✓	✓	✓	✓

Siemens Advanced Motor Master System (SAMMS-MV™)

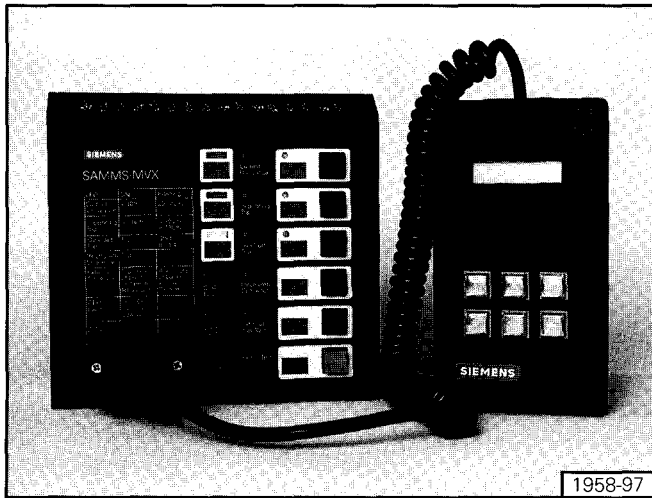

Figure 32. SAMMS-MV Unit and Hand-Held Communicator (HHC)

Diagnostics

The SAMMS-MV unit provides visual diagnostics used to quickly determine the cause of motor problems. The front panel of the controller has eight diagnostic LED's to indicate:

- Current Phase Unbalance
- Impending Overload Trip
- Overload Trip
- External Trip
- Incomplete Sequence
- Ground Fault
- CPU Fault
- Ready (Control Power Status)

In addition, the SAMMS-MV device can provide, as an option, statistical motor data, including the total elapsed motor running time, number of starts, and the number of overload trips. This statistical data is stored in the microprocessor's non-volatile memory and is displayed using the hand-held communicator or using remote communications software. The communicator can also be used as an ammeter to display any of the three phase motor currents.

SAMMS-MV Device Models

SAMMS-MV devices are available in two models, SAMMS-MVX and SAMMS-MVE. Each meets the various demands of industrial and commercial specifications and installations. **Table 6** compares the functions of each model.

The SAMMS-MV device is designed for critical process control where prevention of downtime is crucial. It offers motor control and protection, along with motor diagnostic and motor-driven equipment protection. Engineering and operating personnel have access to important data enabling them to optimize motor-driven equipment capabilities, to maximize the process system output, and to facilitate maintenance.

SAMMS-MVX is a full function model, applicable to all control needs, from a simple across-the-line unit, to a more complicated reduced voltage scheme. It includes all of the functions listed in **Table 6**. Any of the standard control circuits listed in **Table 5**, or a custom circuit, may be downloaded.

SAMMS-MVE is a model tailored to across-the-line non-reversing (FVNR) applications. It is pre-loaded with the FVNR circuits

shown in **Table 5**, and circuit customization is not available. It provides all of the protective functions of the SAMMS-MVX device, except that it has no jam protections (F23), loss of load protection/alarm (F24), or process current warning (F22) functions. Functions F3 and F5 associated with two-speed applications are not available. No provision for automatic reset (F8) is provided. SAMMS-MVE accepts one remote input, and provides one output to actuate a single contactor. An alarm contact is not available with SAMMS-MVE.

SAMMS-MV Instructions

For additional information on operation and maintenance of the SAMMS-MV unit, refer to Instruction Manual MVC-9108.

Table 6. SAMMS-MV Device Functions and Models

Function Number	Function	SAMMS Model	
		MVX	MVE
F0	Ambient Temperature	✓	✓
F1	Control Circuit Number	✓	✓
F2	Size for Overload No. 1	✓	✓
F3	Size for Overload No. 2	✓	—
F4	Full Load Current for OLR No. 1	✓	✓
F5	Full Load Current for OLR No. 2	✓	—
F6	Service Factor	✓	✓
F6A	Motor Type	✓	✓
F7	Overload Trip Class (class 2-23)	✓	✓
F7A	Cold Stall Time	✓	✓
F8	Automatic Reset	✓	—
F9	Phase Unbalance	✓	✓
F10	Time to Restart	✓	✓
F11	Emergency Restart	✓	✓
F12	Ground Fault Protection or Warning	✓	✓
F12A	Ground Fault Pickup Current	✓	✓
F13	Timer No. 1	✓	✓
F14	Timer No. 2	✓	✓
F15	Motor Current	✓	✓
F16	Last Trip Current	✓	✓
F17	Percent Unbalance Current	✓	✓
F18	Total Elapsed Run-Time on Motor	✓	✓
F19	Total Number of Motor Starts	✓	✓
F20	Number of Overload Trips	✓	✓
F21	Reset Motor Data	✓	✓
F22	Set Process Current Warning	✓	—
F23	Jam Protection	✓	—
F23A	Jam Pickup Current	✓	—
F24	Loss of Load Protection or Warning	✓	—
F24A	Loss of Load Pickup Current Pickup Current	✓	—
F25	Motor Winding Temperature as % of Full Load Temperature	✓	✓
F26	Baud Rate	✓	✓
F27	Address	✓	✓

Type 3UA Thermal Overload Relay

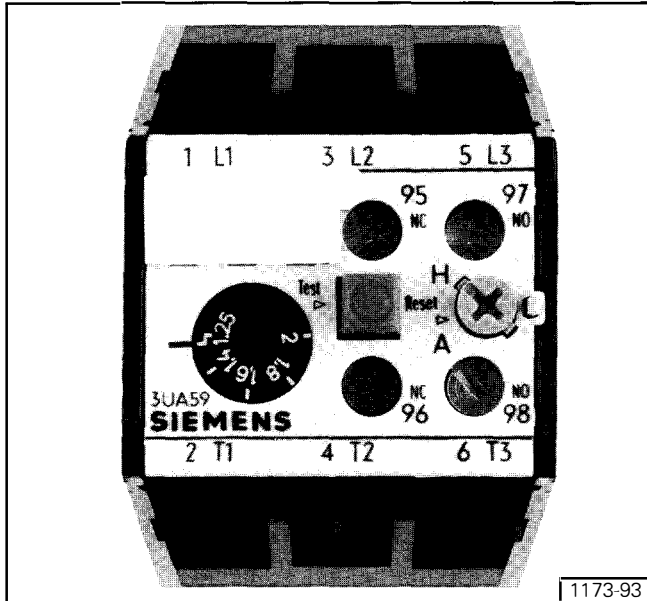

Figure 33. Type 3UA Overload Relay

General

This section is intended to guide the user in the selection, application and setting of the type 3UA thermal overload relay, when used in medium voltage (2.3-6.6kV) motor control applications. It is essential that the information contained here be studied carefully to ensure proper coordination between overload relay and power fuse characteristics.

Overload Relay Operation

The Type 3UA overload relay is designed and factory-calibrated to provide over-temperature protection for the windings of three-phase AC motors. The relay will shut down the motor and/or activate warning alarms under conditions of motor overloading, single-phasing, prolonged acceleration and certain conditions of frequent restarting operations. The internal heaters are energized from the 5 amp secondary windings of the phase current transformers.

Application

Squirrel cage, synchronous and wound-rotor three-phase motors may be protected by the type 3UA overload relay regardless of the type of starting employed. The application table (Table 7) provides the current ranges and corresponding relay catalog numbers for specific motor full load currents divided by the appropriate current transformer ratios.

Markings on the relay adjustment dial denote motor full load amps, divided by the CT ratio. Tripping current is 125% of dial setting. The adjustment dial should be set on the basis of full load current marked on the motor nameplate or on the basis of actual measured running current.

For motors with a marked service factor not less than 1.15, or motors with a marked temperature rise not over 40°C, use the formula below for determining the dial setting:

$$\text{Dial Setting (for 1.15 SF)} = \frac{\text{Nameplate Full Load Current}}{\text{Current Transformer Ratio}}$$

In case overload relay tripping occurs during motor starting or at maximum running conditions, the overload relay dial setting can be increased by a factor not to exceed 1.12 times the value determined by the above formula in accordance with NEC Article 430-34.

For all other motors rated for continuous duty including motors with a marked service factor of 1.0, use the formula below for determining the dial setting:

$$\text{Dial Setting (for 1.0 SF)} = \frac{(0.92) (\text{Nameplate Full Load Current})}{\text{Current Transformer Ratio}}$$

In case overload relay tripping occurs during motor starting or at maximum running conditions, the overload relay dial setting can be increased by a factor not to exceed 1.04 times the value determined by the above formula in accordance with NEC Article 430-34.

NOTE: If the motor is a hermetically sealed type (sometimes used for air conditioning or refrigeration drives) a magnetic type overload relay is normally required due to the inherent limited thermal winding capacities of these motors. Check application.

After the dial setting has been determined, the relay having a current range that will include the dial setting should be chosen. The dial setting must be made on each relay for the individual motor application.

For example, for a particular motor, nameplate full load current is 200 amps, nameplate service factor is 1.15 and current transformer ratio is 300/5 amps. Then, using the first formula,

$$\text{Dial Setting} = \frac{200}{300/5} = 3.33$$

The relay with a range that will include the dial setting of 3.33 amps must therefore be used. From Table 7, relay catalog number 3UA59 00-1E would be chosen having a setting range from 2.5 to 4.0 amps. This setting permits the motor to run up to its full service factor before tripping will occur. Note that relay 3UA59 00-1F (3.2 - 5.0 amps) could have been chosen for this application. Either relay will work and selection is optional.

Table 7. 3UA Overload Relay Application

Minimum Amps	Maximum Amps	Relay Catalog No.
1.6	2.5	3UA59 00-1C
2.0	3.2	3UA59 00-1D
2.5	4.0	3UA59 00-1E
3.2	5.0	3UA59 00-1F

Cyclic Starting

Thermal overload relays accumulate heat on operation and approximately two minutes cooling time should elapse before attempting to reset relays after tripping has occurred. Even though the relay can be successfully reset, its operating time on restart after tripping may be considerably shorter than that from a cold start. Approximately one hour cooling time is required for the relays to cool completely to room temperature after they have been de-energized.

Type 3UA Thermal Overload Relay

Thermal overload relays will trip due to accumulated heat from jogging or frequent restarting operations. However, thermal overload relays may not protect motors completely if frequent restarting after tripping is attempted because the cooling time of the motors which they are protecting is considerably longer than that of the relay elements. Jogging and cyclic starting should be kept to an absolute minimum to prolong motor and controller life.

Cyclic Loading

Thermal overload relays may have a tendency to over-protect motors which serve highly fluctuating loads. With this type of loading, the operating elements of the thermal overload relays tend to accumulate the heat produced by the load peaks and cause tripping even though the effective loading may be well within motor rating.

The effect of a pulsating type of drive can be determined by calculating the root-mean-square value from a recording current chart or by using a planimeter with a current chart showing a typical load cycle. Should tripping occur when the effective loading is within the rating of the motor, the setting of the relay can be proportionally increased to correspond to the effective loading. If a satisfactory setting cannot be obtained, the factory should be consulted after full details of application and loading are obtained.

Single-Phasing

The Type 3UA thermal overload relay provides protection for three-phase motors against overheating in the event of a single-phase or phase current unbalance condition. When any of the three phases is opened, the relay senses this and its curve shifts to a faster time-current characteristic, thus making it more sensitive to the higher single phase current. If the relay trips, it could be due to either a normal three-phase overload or single phase condition.

Causes for Relay Tripping

Should overload relay tripping occur from a cold start-up, abnormal starting conditions exist. The line voltage should remain close to normal even while the motor is drawing high starting current. The torque that the motor will develop is proportional to the square of the applied voltage. For example, should the line voltage drop 10% from normal, the motor will develop approximately 81% as much torque as on rated terminal voltage. Any loss in developed torque may produce a marginal acceleration condition. Such loads as pumps, compressors, fans, etc., are normally started unloaded.

Improper operation of the unloading features may extend the accelerating time to cause overload relays to operate. Certain high inertia loads may inherently have accelerating times in excess of that which overload relays will tolerate without tripping. This condition may exist on drives such as hammermills or impactors, roll and jaw crushers, large blowers, flywheel m-g sets, chippers, etc.

Where motors have been established as suitable for the normally long accelerating times, it may be necessary to bypass the overload relays during the starting interval. This can be done by the addition of controlled shorting contacts. Problems of this nature should be referred to the factory with complete operational details. The motor load current should always be measured when relay tripping occurs. The most common cause of relay tripping is the simple fact that the motors are overloaded during operation.

Operational Checks

Under normal operating conditions overload relays never operate. After prolonged periods in certain atmospheres (corrosive, dusty, or gummy), it is possible that they may not operate properly. The following operational test will demonstrate if the overload relay is functioning properly at the existing calibration setting. This operational test should be included as a part of the periodic maintenance schedule.

Test Procedures

Observe the following precautions while making the operational test:

1. All relay components must be at the same temperature at the start of each test run. It may be necessary to wait approximately one hour between each test run.
2. If the relay is used to set the load, then it should cool one hour before proceeding with the test.
3. The current must be held at the test value during the test run.
4. If a laboratory type ammeter is not available, then allowance must be made for the inaccuracy of standard meters.

Type 3UA Thermal Overload Relay

Operational Test

Refer to **Figure 34** for test equipment required and connections. Proceed as follows:

1. Check dial setting of relay as outlined in "Application" section of these instructions.
2. Adjust variable autotransformer to supply three times the current indicated on the overload relay dial. Relay should trip in 17-37 seconds.

NOTE: A slight adjustment of the dial setting may be necessary to arrive at this trip time. If a slight adjustment is made, it is recommended that the 100% current test be made as outlined below.

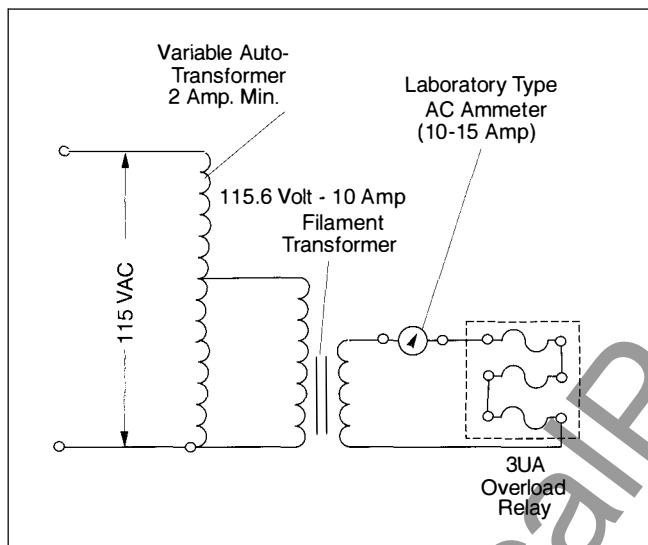

Figure 34. Connections and Equipment for Operational Test or Calibration of Type 3UA Overload Relay

100% Current Test

The 100% current test provides a close check of relay operation. Proceed as follows:

1. Apply 115% of the dial setting current through all three elements of the relay. Relay should not trip within 3/4 hour.
2. Apply 125% of the dial setting current through all three elements of the relay. Relay should trip within 3/4 hour.

All relay operating elements must have cooled down to room temperature before repeating the test or the trip times will be substantially faster than indicated. Should a motor be running near full load and jam or stall, the relays will trip in approximately one-fourth of the time from a cold start. Should careful checking of any relays reveal them to be significantly out of calibration, they may have been subjected to tampering or handling damage and should be replaced.

Coordination with Current-Limiting Motor Fuses

The overload relay time-current characteristics must be selected so that the power fuses are protected against unnecessary operation or damage during motor starting or overload conditions. In a properly coordinated system, the overload relay will operate to open the main contactor before the fuse melts under motor locked-rotor conditions. The combination of type 3UA overload relay and power fuse rating supplied in Series 81000 controller is factory-selected to provide proper fuse coordination and optimum motor protection.

Proper coordination also ensures that the motor fuse cannot be subjected to currents below its minimum interrupting rating (currents which require over 100 seconds to melt the fuse) for a period of time long enough to cause overheating and damage to the fuse. The overload relay must be set to trip and open the contactor at currents in this range before the fuse becomes so overheated that it cannot interrupt.

The overload relay and fuse characteristics can be compared by overlaying the transparent time-current curve for the overload relay with the fuse minimum melting time curves. The curves should be positioned one over the other on a light table so that the 100% current mark on the overload curve is aligned with the current on the fuse curve corresponding to the dial setting on the overload relay. For proper fuse protection, the intersection of the two curves must occur at a point under 100 seconds.

NOTE: Installation of power factor correction capacitors can affect overload relay trip setting.

If the capacitors are connected to the load (motor) side of the current transformers or directly to the motor, the overloads must be derated. A five percent decrease in the trip setting would be a nominal requirement. To accurately determine the proper setting, operate the motor with the capacitors disconnected and measure the secondary current of the current transformers. Connect the capacitors and again measure the secondary current. Calculate the percentage difference and decrease the trip setting accordingly.

Type 3UA Thermal Overload Relay

Current Characteristic Curves
 Type 3UA Thermal Overload Relay - NEMA Class 10
 Cat. No. 3UA5900-1E, Setting Range 2.5-4.0 Amp
 Medium Voltage Control Applications

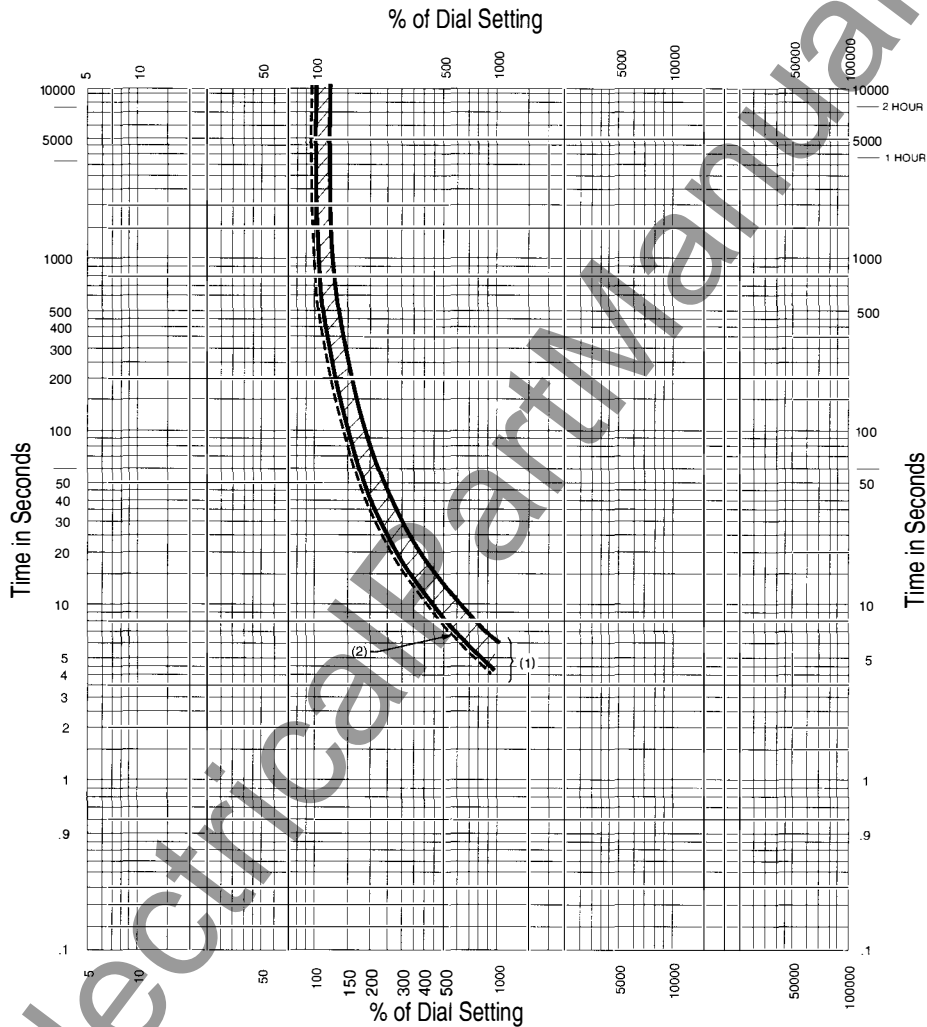

NOTES:

1. Curves are based on "cold" start at 25°C ambient. For full running condition tripping times are lowered to 25% of indicated values.
2. Band (1) shows maximum and minimum tripping characteristics for normal three-phase balanced load.
3. Curve (2) shows maximum tripping times for single-phase conditions.
4. Motor (line) current is equal to overload relay current multiplied by current transformer ratio.

Relay Cat. No.	Setting Range
3UA59 00-1C	1.6-2.5 Amps
3UA 59 00-1D	2.0-3.2 Amps
3UA 59 00-1E	2.5-4.0 Amps
3UA59 00-1F	3.2-5.0 Amps

Figure 35. Time-Current Characteristic Curves of Type 3UA Overload Relay

	⚠ DANGER
	Hazardous voltages.
	Will cause death, serious personal injury or property damage.

Disconnect, lockout, and ground incoming power and control voltage sources before beginning work on this or any other electrical equipment.

All pre-energization checks outlined in this instruction manual must be performed before the equipment is energized. This equipment should be energized by qualified personnel only.

Pre-Energization Check

After installation, field additions, or maintenance, the following checklist should be followed:

1. Remove all blocks or other temporary holding means used for shipment from all component devices in the controller interior. If the retaining bracket used for shipment of the contactors has not been removed, remove the retaining bracket which secures the left front contactor wheel to the guide plate.
2. Retighten all accessible connections in accordance with the torque values provided in **Table 10** of the Maintenance section of this manual.
3. Check the integrity of the bus supports.
4. Check the enclosure to see that it has not been damaged and that electrical spacing has not been reduced.
5. Compare all circuits for agreement with the wiring diagrams which accompany the controller.
6. Make certain that external wiring is clear of bus, and all power wiring is physically secured to withstand the effects of the largest fault current which the supply system is capable of delivering.
7. Verify that all ground connections have been made properly. If sections of the controller were shipped separately, they must be connected in a manner to assure a continuous ground path.
8. Check all devices for damage. Make necessary repairs or replacement prior to energizing.
9. Be sure that each motor is connected to its intended starter. Ensure that fuse rating is in agreement with the rating specified in the contactor catalog number.
10. Manually exercise all operating mechanisms, contactors, magnetic devices, and other devices to make certain that they are properly aligned and operate freely.
11. With all loads disconnected, exercise all electrically operated devices with test power to determine that they operate properly. Refer to the wiring diagrams for the required control voltage, frequency, and test power terminal designations required to test the contactor. For the contactor, this should also include tests at the lower limits of pickup voltage as shown in the instruction manual for the contactor.
12. Test the ground fault protection system (if furnished) in accordance with the manufacturer's instructions.
13. Set all devices with adjustable current and/or voltage settings to proper values.
14. Ensure that overload relay current range and setting is in agreement with the full load current and service factor shown on the nameplate of each motor, taking into account the current transformer ratio used in the controller.
15. Make sure that all fuses are completely inserted in the clips.
16. Install any necessary CT circuit wiring, and remove CT short circuiting jumpers installed for shipment. (Do not remove CT short circuiting jumpers if no load circuit is connected to the CT). If short circuiting type terminal blocks are provided, assure that short circuiting screws are removed or shorting links are in the open position. Check each current transformer secondary circuit for continuity through its protective devices to ground. Do not operate a motor controller with a current transformer's secondary circuit open.
17. To prevent possible damage to equipment or injury to personnel, check that all parts and barriers that may have been removed during wiring and installation have been properly reinstalled.
18. Before closing the enclosure, remove all metal clips, scrap wire, and other debris from the controller interior. Remove any accumulation of dust or dirt, clean out the controller by using a brush, vacuum cleaner or clean lint-free rags. Do not use compressed air, as it will only redistribute contaminants on other surfaces.
19. After all of the power and control connections are made and with all incoming power disconnected, conduct dielectric tests in accordance with the "Dielectric Test" section of this manual.
20. Install covers, close doors, and make certain that no wires are pinched and that all enclosure parts are properly aligned and tightened.
21. Make sure that all current-carrying parts outside the controller have adequate current-carrying capacity and are correctly insulated in accordance with the requirements of the National Electric Code (NEC). All electrical connections should be made carefully per the wiring diagram furnished with the equipment. Tighten all terminals to recommended torque values (see **Table 10**). Use recommended crimping tools if crimp lugs are supplied.

Dielectric Test

	⚠ DANGER
	<p>Hazardous voltages.</p> <p>Will cause death or serious injury.</p> <p>Follow safe procedures. Exclude unnecessary personnel. Use safety barriers. Keep away from equipment during application of test voltages. Dielectric or megger testing should only be conducted by qualified personnel. Refer to dielectric test equipment instructions for safety instructions.</p>

An AC dielectric test, at 2.25 times the nominal system voltage plus 2000 volts for one minute, should be performed between all phases and from all phases to ground prior to energizing the equipment. Be sure to disconnect from the circuit any devices (control power transformer, surge limiters, surge arrestors, etc.) which could be damaged by the test voltage.

If a high-potential test set is not available, a megger test at 1000 volts is a suitable second choice.

Since wide variations can occur in insulation values because of atmospheric conditions, contamination and type of test equipment, discrete values for acceptability cannot be given. However, making and recording tests on new equipment, and again at regular intervals, will give a comparative indication of change in the condition of insulation. Maintaining a permanent record of these values should be part of the maintenance program.

	⚠ WARNING
	<p>Vacuum interrupters may emit x-ray radiation.</p> <p>Can cause personal injury.</p> <p>Excessive dielectric test voltages can cause x-radiation to be emitted from vacuum interrupters.</p> <p>Refer to vacuum contactor instruction manual for dielectric test procedures applicable to the vacuum contactor.</p>

Note: Do not use DC high potential testers incorporating half-wave rectification. These devices produce high peak voltages.

These high voltages will produce X-ray radiation. These devices also show erroneous readings of leakage current when testing vacuum interrupters.

Energizing Equipment

	⚠ WARNING
	<p>Hazardous voltages.</p> <p>Can cause death, serious personal injury, or equipment damage.</p> <p>Complete all pre-energization checks outlined in this instruction manual before the equipment is energized.</p>

1. In order to minimize risk of injury or damage, or both, there should be no load on the controller when it is initially energized. Turn off all of the downstream loads, including those such as distribution equipment and other devices which are remote from the controller.
2. The equipment should be energized in sequence by starting at the source end of the system and working towards the load end. In other words, energize the incoming power to the controller or group of controllers, then close the incoming line load interrupter switch or circuit breaker (if available) and then rack in the contactor.
3. After all disconnect devices have been closed, loads such as motors may be turned on to verify that the system operates as intended.

Operation

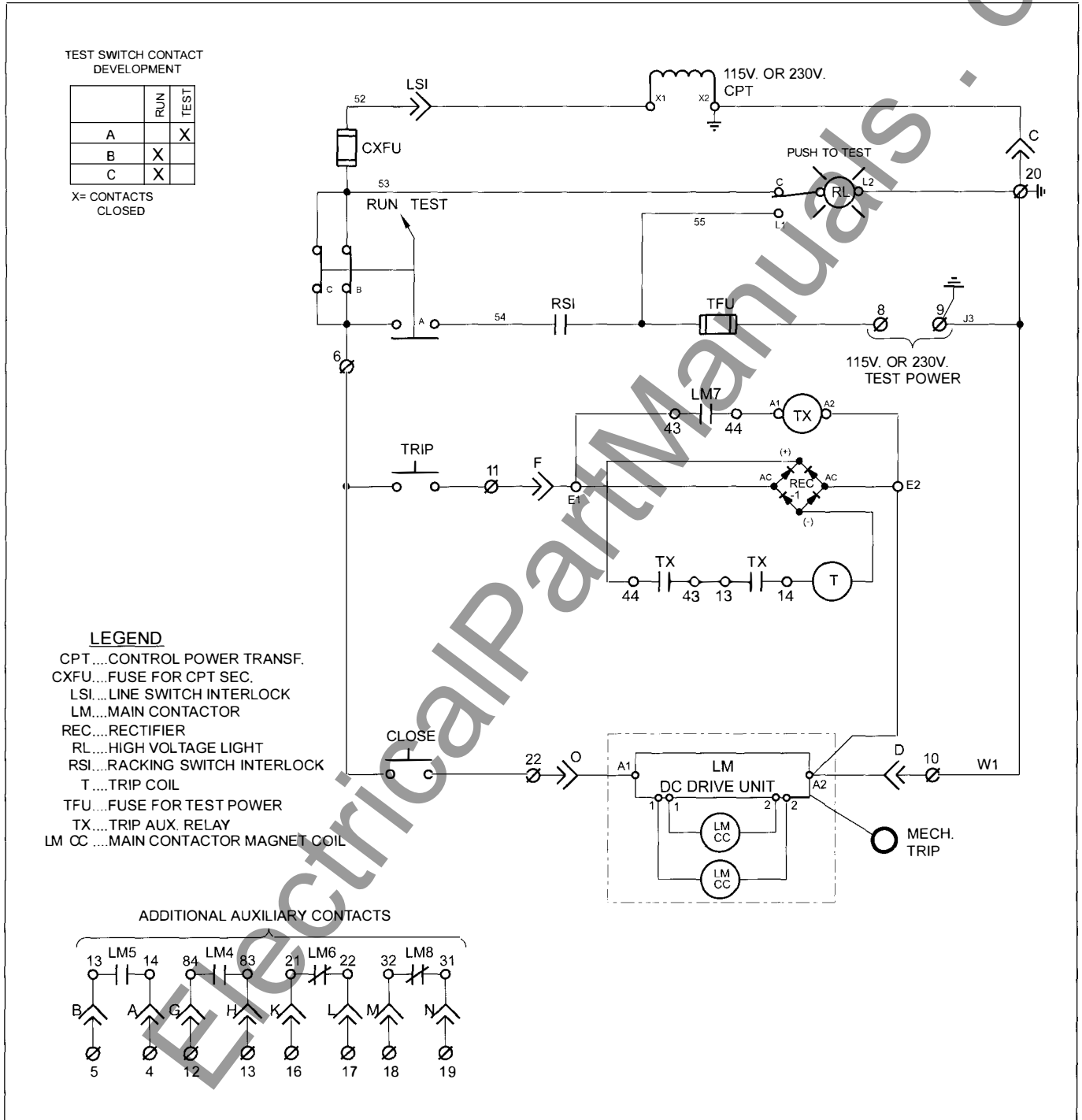



Figure 36. Typical Control Circuit Diagram with Type 96H3 or 97H3 Contactor (Latched Contactor with Electrical Trip)

	⚠ DANGER
	Hazardous voltages.
	Will cause death, serious personal injury or property damage.

Disconnect, lockout, and ground incoming power and control voltage sources before beginning work on this or any other electrical equipment.

⚠ WARNING
Failure to properly maintain the equipment can result in death, serious personal injury, or product failure, and can prevent successful functioning of connected apparatus.
The instructions contained herein should be carefully reviewed, understood, and followed.
The maintenance tasks in Table 8 must be performed regularly.

Introduction

Before performing any maintenance:

- Test all power terminals to verify that incoming power has been disconnected. Use only approved high voltage test equipment to check voltage on power terminals. **Do not attempt to measure high voltage (over 600 volts) with a volt-ohm meter.**
- Check all control and secondary circuit terminals with a voltmeter to make certain that all sources of incoming control and secondary voltage have been disconnected.
- Connect safety grounds to power terminals after the system has been de-energized, and prior to working on the equipment.
- Perform all disconnecting, grounding, and lockout operations in accordance with established safety procedures.
- Follow the procedure outlined in the Pre-Energization Check section of this manual before power is restored.

General

For the safety of maintenance personnel as well as others who might be exposed to hazards associated with maintenance activities, the safety related work practices of NFPA 70E, parts II and III should always be followed when working on electrical equipment. Maintenance personnel should be trained in the safety practices, procedures and requirements that pertain to their respective job assignments. This manual should be reviewed and retained in a location readily accessible for reference during maintenance of this equipment.

The user must establish a periodic maintenance program to ensure trouble-free and safe operation. The frequency of inspection, periodic cleaning and preventive maintenance will depend upon the operating conditions. NFPA Publication 70B "Electrical Equipment Maintenance" may be used as a guide to establish such a program. **A preventive maintenance program is not intended to cover reconditioning or major repair, but should be designed to reveal, if possible, the need for such actions in time to prevent malfunctions during operation.**

Recommended Maintenance and Lubrication

Periodic maintenance and lubrication should include all of the tasks shown in **Table 8**. Recommended procedures for each of the listed tasks are provided in this section of the manual, or in the references cited in this manual.

Table 8. Maintenance Tasks

<ul style="list-style-type: none">• Mechanical and electrical operation of the contactors• Vacuum contactor inspection• Shutter mechanism inspection• Racking mechanism check• Mechanical interlocks check• Electrical interlock check• Check of terminals and joints• Periodic Cleaning• Dielectric test• Overload relay checks

The list of tasks in **Table 8** does not represent an exhaustive survey of maintenance steps necessary to ensure safe operation of the equipment. Particular applications may require further procedures. Should further information be desired or should particular problems arise which are not covered sufficiently for the Purchaser's purposes, the matter should be referred to the local Siemens sales office.

⚠ DANGER
Use of unauthorized parts in the repair of the equipment, altering of the design, or tampering by unqualified personnel will result in dangerous conditions.
Will cause death, serious personal injury, or equipment damage.
Follow all safety instructions contained herein.

Mechanical and Electrical Operation of the Controller

1. Carefully inspect the doors, enclosure sides and dead front surfaces over all units for excessive heat. As a general rule, temperature which the palm of the hand cannot stand for about 3 seconds may indicate trouble. Infra-red heat detectors are available for this purpose of detecting heat problems.
2. Inspect the controller a minimum of once each year, or more often as deemed necessary. Look for any moisture or signs of previous wetness or dripping inside the controller. Condensation in conduits or dripping from an outside source is a common cause of failure.
 - a. Seal off any conduits that have dripped condensate, and provide an alternative means for the conduit to drain.
 - b. Seal off any cracks or openings which have allowed moisture to enter the enclosure. Eliminate the source of any dripping on the enclosure and any other source of moisture.
 - c. Replace and thoroughly dry and clean any insulating material which is damp or wet or shows any accumulation of deposited material from previous wettings. Conduct an electrical insulation resistance test as detailed in "Pre-Energization Check" in the Operation section of this manual, to verify the dielectric integrity of the affected insulation.

Maintenance

3. Check all devices for missing or broken parts, proper spring tension, free movement, rusting or corrosion, dirt and excessive wear.
4. Examine all readily accessible insulating parts for cracks or breakage and for arc splatter, sooty deposits, or oil. Clean off arc splatter, oil and sooty deposits, replace if any signs of burning, charring or carbon tracking are found. Make sure that the dielectric integrity of the affected parts is maintained.
5. Measure resistance across each contactor pole from the line to the load terminal as indicated in **Figure 37**. If the resistance exceeds the values indicated in **Table 9**, loosen connections and perform the following procedure:
 - a. Examine all joints for plating wear, replace if necessary.
 - b. Clean all surfaces. Replace parts if oxide films have formed.
 - c. Examine spring pressure by comparing it to other similar springs, replace if necessary.
 - d. Retighten all connections in accordance with the recommended torque values, **Table 10**.
 - e. Be sure that the conditions that caused the high resistance values, have been corrected before resuming service.

Table 9. Maximum resistance across line-to-load terminals of each pole of the Series 81000 contactors.

Contactor Type	Fuse "R" Rating	Maximum Resistance (Main Contacts Closed) Milliohms at 20°C
96H35 97H35	None	1.0
	2R	11.9
	3R	7.3
	4R	5.6
	6R	4.1
	9R	3.1
	12R	2.7
	18R 24R	2.0 1.8
96H37 97H37	None	1.0
	2R	11.0
	3R	7.3
	4R	5.7
	6R	4.1
	9R	3.1
	12R	2.6
	18R 24R	2.0 1.8

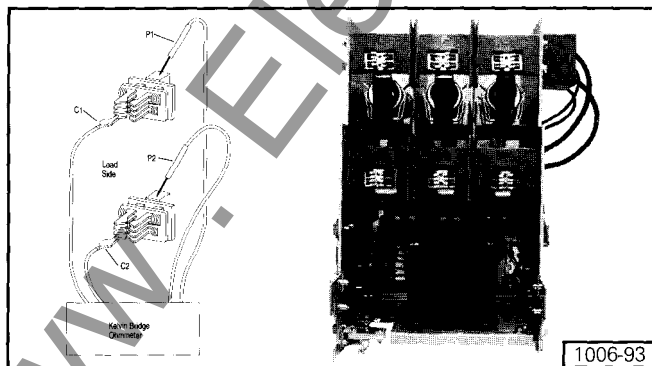

Figure 37. Connection to Measure Contactor Pole Resistance

Vacuum Contactors

Maintenance instructions for medium voltage contactors are presented in SGIM-9088A.

Shutter Mechanism

⚠ WARNING

Hazardous voltages.

Energized parts located behind shutter mechanism will cause death, serious personal injury, or property damage.

Disconnect, ground, and lockout incoming power before performing any maintenance or inspection of the shutter mechanism.

It is necessary to visually inspect the shutter mechanism components every time the contactor is removed from the cell module. Periodic checks are strongly recommended. Replace broken parts and adjust linkage to provide a bind-free motion.

Racking Mechanism Adjustment

⚠ WARNING

Hazardous voltages.

Will cause death, serious personal injury, or property damage.

Disconnect, ground, and lockout incoming power before performing any maintenance or inspection of the racking mechanism.

The racking mechanism for the Series 81000 controllers is designed for smooth and easy operation. The mechanism is factory adjusted and with normal use, no maintenance is required, except for a light coat of grease (Siemens part no. 15-172-816-058) at the moving joints. When properly adjusted, the racking mechanism will provide the correct amount of line and load power stab finger engagement and LSI engagement shown in **Figure 38**. In order to check for proper engagement of the contactor in the cell, the following procedure is recommended:

1. Disconnect all incoming power.
2. Connect an ohmmeter or buzzer between any one stationary stab terminal and its mating disconnect finger assembly on the contactor.

⚠ WARNING

Hazardous voltages may be developed across the control transformer primary winding.

Can cause death or serious personal injury.

Disconnect the wire from the LSI finger assembly to the control transformer "X1" terminal before applying any voltage to the LSI. Reconnect the wire after testing is completed.

Maintenance

- 3 Rack the contactor in by moving the handle to the ON position. Continuity should be indicated on the power stab and the LSI.
- 4 Slowly rack the contactor out by moving the handle toward the OFF position until the LSI opens as indicated by the ohmmeter. The handle position should be as indicated in **Figure 39**. Continue moving the handle toward OFF and observe the point at which the power disconnect finger assembly disengages from the stab terminal. This should occur in 15° $\pm 5^\circ$ handle travel past the point at which the LSI opens.
- 5 If the LSI does not open at the specified handle position, the LSI stationary terminal may be adjusted by loosening the mounting screws and sliding forward or back on the guide plate as necessary. Do not change the location of the LSI finger assembly on the contactor.

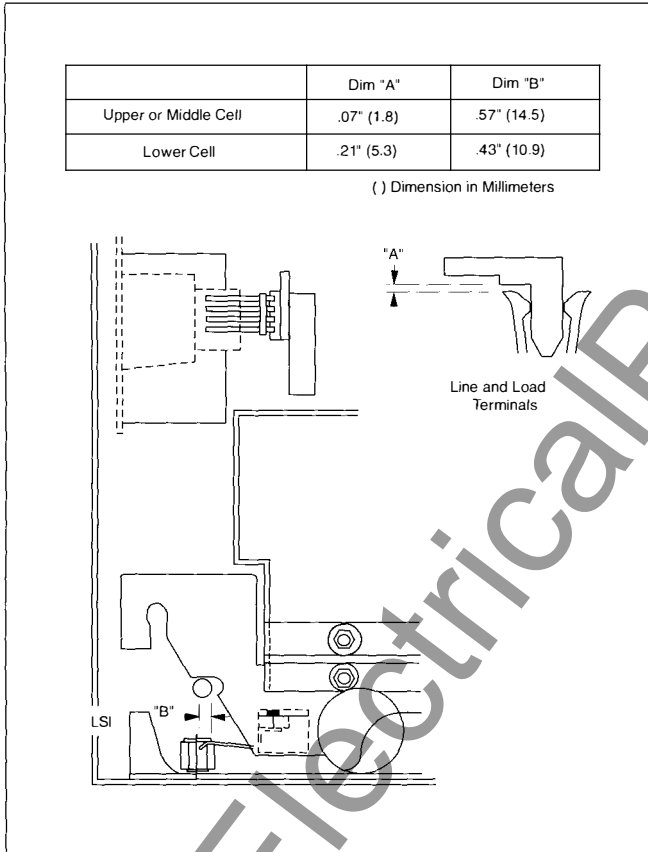

Figure 38. Check for Proper Stab Finger and LSI Connection

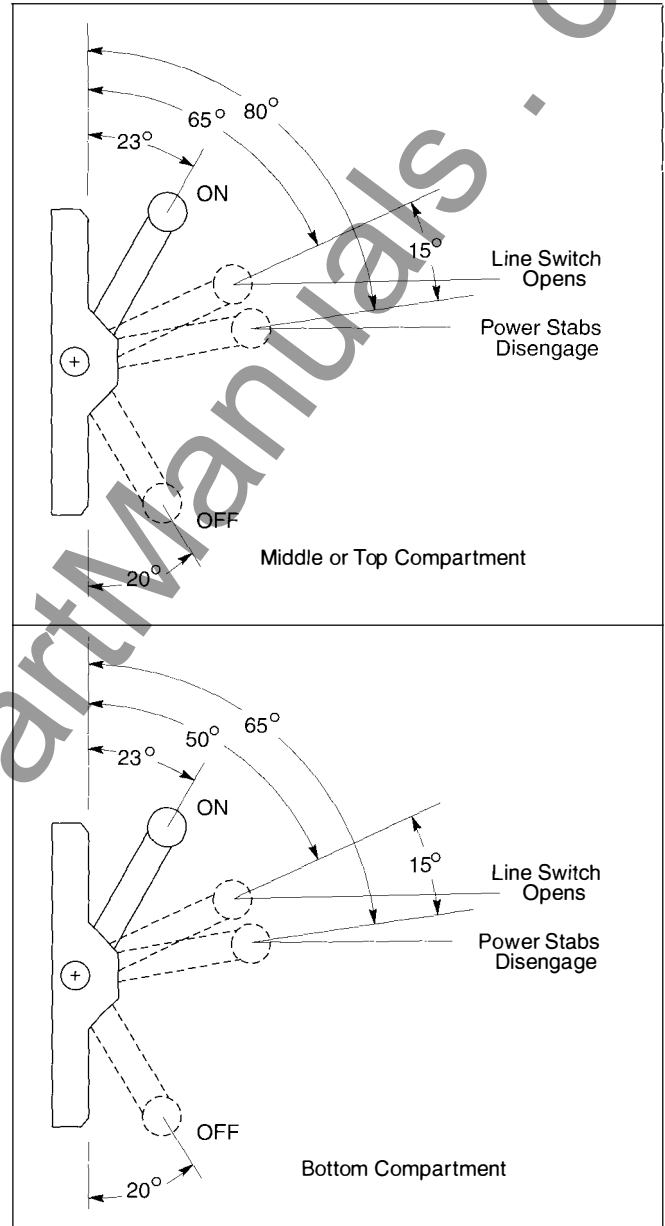

Figure 39. Racking Mechanism Adjustment

Maintenance

If the proper amount of engagement of the power stab fingers and/or the LSI cannot be obtained, perform the following adjustment procedure:

1. Disconnect all incoming power to the controller, open the medium voltage compartment door, rack out and remove the contactor from the compartment.
2. Loosen the lock nuts on each end of the long connecting rod and adjust the length of the rod by rotating it until the dimension shown in **Figure 12** or **Figure 14** is obtained. Retighten the locknuts.
3. Defeat the door interlock lever by pushing it in with a screwdriver and move the handle to the ON position. Be sure the driver link pin engages the notch in the detent lever.
4. Manually rotate the contactor interlock lever so that the tab on the end of the lever engages the notch in the cam.

Loosen the lock nuts on each end of the short connecting rod and adjust the length of the rod by rotating it until the dimension between the tab and the cam notch shown in **Figure 40** is obtained. Retighten the locknuts.

NOTE: Cells located in bottom compartments are deeper than cells in middle or upper compartments. The racking mechanism linkages for bottom cells are slightly different and must be adjusted differently from those of shorter cells which are located in middle or upper compartments. Depending on cell location, determine the proper dimension between the tab and cam notch from **Figure 40** and adjust the mechanism accordingly.

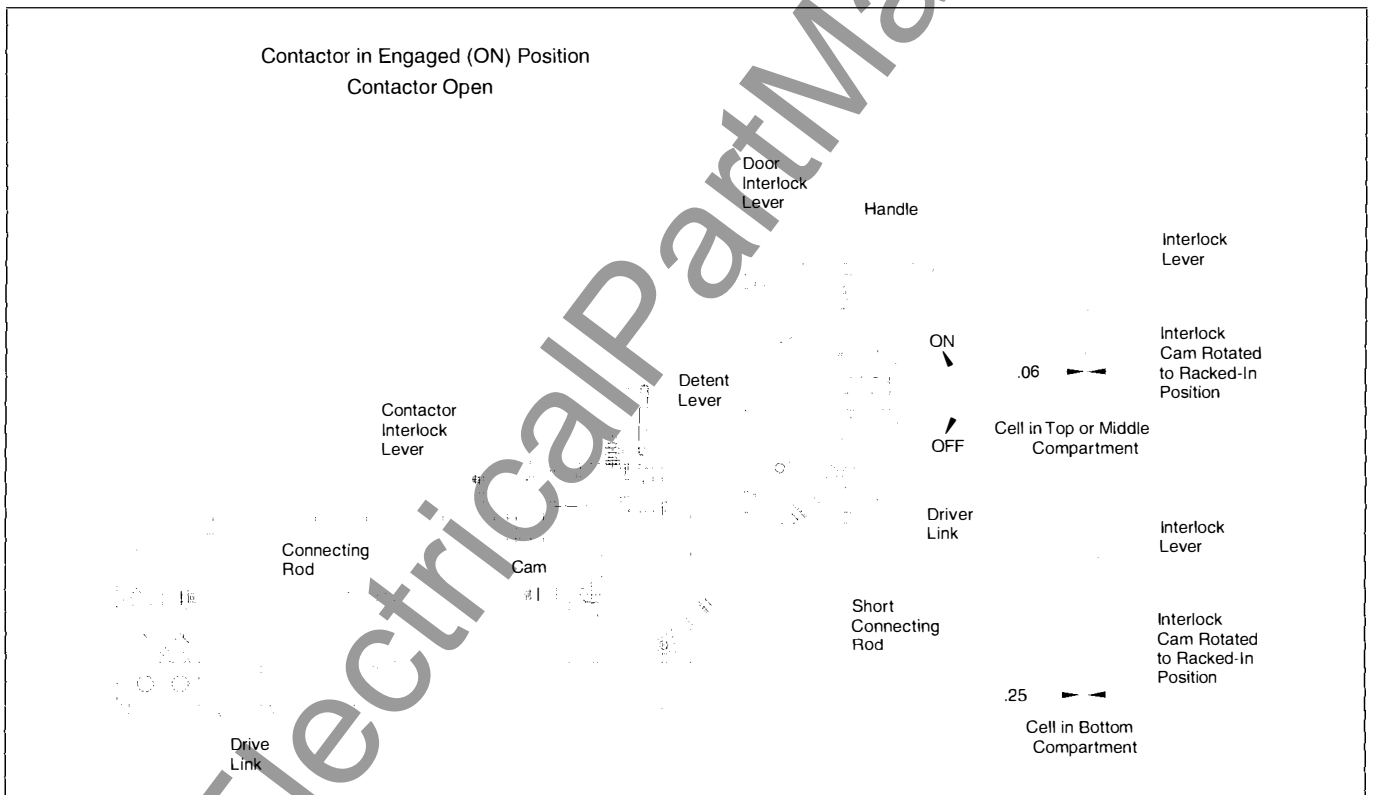



Figure 40. Racking Mechanism Adjustment - ON Position

Mechanical Interlocks

	⚠ WARNING
	Hazardous voltages.
	Can cause death, serious personal injury, or property damage.
Do not attempt to use excessive force or leverage to defeat the mechanical interlocking system and gain access to the high voltage unit.	

Interlocks are designed to help prevent possible personal injury or equipment damage resulting from accidental or intentional misuse of equipment.

Never attempt to operate this equipment unless all interlocks are installed and operating properly.

	⚠ DANGER
	Hazardous voltages.
	Will cause death, serious personal injury, or property damage.
Do not perform the check of interlock lever engagement unless all incoming power is disconnected, grounded, and locked out.	

All mechanical interlocks are factory adjusted, for smooth and positive operation. Maintenance should include the following items:

1. A light coat of grease (Siemens part no. 15-172-816-058) on the moving parts and pivots every year or 20,000 operations, whichever comes first.
2. Adjustment to allow the interlocking levers and latches to pivot freely.
3. Check interlock lever engagement as shown in **Figure 41**. Replace assembly, Siemens part no. 25-154-488-877, if engagement is less than 0.12 in. (3mm).

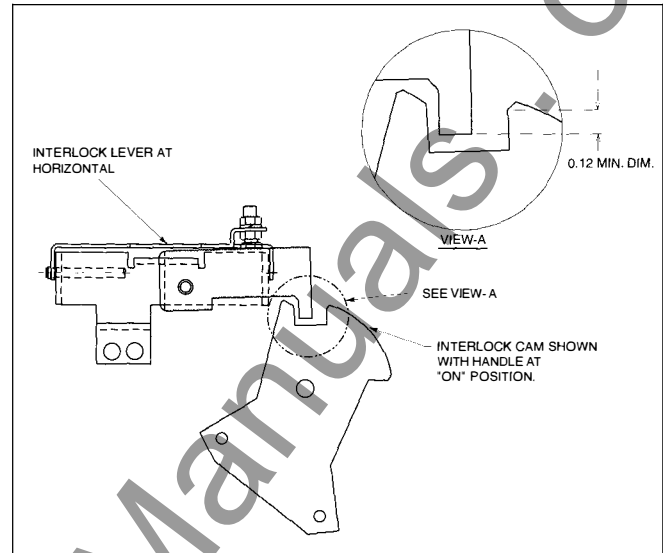

Figure 41. Interlock Lever Engagement Check

Electrical Interlocks

Line Switch Interlock (LSI) - See Racking Mechanism Adjustment

Racking Switch Interlock (RSI) - Refer to **Figure 6**. Inspect for mechanical and electrical integrity of the switch. To adjust, loosen the two screws connecting the mounting bracket to the guide plate, and locate the roller of the microswitch under the cam assembly of the rear shaft.

Electrical Joints and Terminals

Carefully inspect all visible accessible electrical joints and terminals in the bus and wiring system.

1. Retighten bolts and nuts at bus joints if there is any sign of overheating or looseness. Refer to "Recommended Torque Values", **Table 10**.
2. If joints or terminations appear to be badly discolored, corroded or pitted, or show evidence of having been subjected to high temperatures, the parts should be disassembled and cleaned or replaced.
3. Examine all wire or cable connections for evidence of looseness or overheating. Retighten, if necessary. If major discoloration of cable insulation or if cable damage is apparent, replace the damaged portion of the cable.
4. Closely examine fuse clips. If there is any sign of overheating or looseness, check the spring pressure, tightness of clamps, etc. Replace the fuse clips if the spring pressure compares unfavorably with that of other similar fuse clips in the controller. Make sure that fuses are completely inserted.

Maintenance

5. Examine all joints for plating wear, replace if the plating is worn out. Special attention should be paid to the stab fingers under such adverse environmental conditions where sulfur dioxide, chlorine, some hydrocarbons and saltwater exist in the atmosphere. Replace if evidence of copper oxide or other films have formed. Use Siemens contact lubricant number 15-171-370-002 to protect the stab finger joint from deterioration. Worn plating on the stabs can result in overheating and may lead to flashover. Plating wear through can be expected after approximately 1500 racking operations.
6. Examine insulation on conductor for overheating or chafing against metal edges that could progress into an insulation failure. Replace any damaged conductors, and ensure replacement conductors are braced or shielded if needed to avoid similar damage in future operation.
7. Be sure that any conditions that caused overheating have been corrected.

Periodic Cleaning

Accumulation of dust and foreign material such as coal dust, cement dust, or lampblack must be removed from the controller and all surfaces must be wiped clean at regular intervals. Dust can collect moisture, causing voltage breakdown. Do not use compressed air as it will only redistribute contaminants on other surfaces.

Dielectric Test

Perform tests as discussed in the "Dielectric Test" section of this manual.

Overload Relay Checks

Perform "operational checks" as described in the "Type 3UA Thermal Overload Relay" section of this manual. For other relays and protective devices, consult the manual for the specific device for periodic checks and tests.

Recommended Torque

When making bolted assemblies, the following considerations should be generally followed. The recommended torque is determined by the size and type of hardware used. Refer to **Table 10**.

Recommended Torque

When making bolted assemblies, the following considerations should be generally followed. The recommended torque is determined by the size of hardware used. Refer to **Table 10**.

1. Metal-to-Metal - Apply standard torque as listed.
2. Metal-to-Insert molded in compound part - Apply approximately 2/3 of standard torque.
3. Compound-to-Insert molded in compound part - Apply approximately 1/2 of standard torque.
4. Compound-to-Compound - Apply approximately 1/2 of standard torque.

Table 10. Recommended Torque Values

Thread Size	Standard Torque Metal-to-Metal (in-lbs/Nm)	2/3 Standard Torque Metal-to-Insert (in-lbs/Nm)	1/2 Standard Torque Compound-to-Insert (in-lbs/Nm)	1/2 Standard Torque Compound-to-Compound (in-lbs/Nm)
8-32	14-20/1.6-2.3	10-14/1.0-1.6	7-10/0.8-1.2	7-10/0.8-1.2
10-32	20-30/2.3-3.4	13-20/1.6-2.3	10-15/1.2-1.8	10-15/1.2-1.8
1/4-20	40-60/4.5-6.8	26-40/3.2-4.5	20-30/2.3-3.4	20-30/2.3-3.4
5/16-18	168-228/19-25.8	110-150/12.4-17	84-114/9.5-13	84-114/9.5-13
3/8-16	240-360/27-41	160-240/18-27	120-180/13.5-20.5	120-180/13.5-20.5
1/2-13	480-600/54-68	320-400/36-45	240-300/27-34	240-300/27-34

Maintenance After a Fault has Occurred

	⚠ DANGER
	Hazardous voltages.
	Will cause electric shock, burn or electrocution.

Disconnect, ground, and lockout incoming power and control voltage sources before beginning work on this or any other electrical equipment.

Only qualified personnel should be involved in the inspection and repair procedure and all plant safety procedures must be observed.

Introduction

Before performing any maintenance:

- Test all power terminals to verify that incoming power has been disconnected. Use only approved high voltage test equipment to check voltage on power terminals. **Do not attempt to measure high voltage (over 600 volts) with a volt-ohm meter.**
- Check all control and secondary circuit terminals with a voltmeter to make certain that all sources of incoming control and secondary voltage have been disconnected.
- Connect safety grounds to power terminals after the system has been de-energized, and prior to working on the equipment.
- Perform all disconnecting, grounding, and lockout operations in accordance with established safety procedures.
- Follow the procedure outlined in the "Pre-Energization Check" section of this manual before power is restored.

General

The excessive currents occurring during a fault may result in structure, component and/or conductor damage due to mechanical distortion, thermal damage, metal deposits, or smoke. After a fault, repair the cause of the fault, inspect all equipment per NEMA Standards Publication No. ICS-2, Annex A, and make any necessary repairs or replacements prior to placing the equipment into service again. Be sure that all replacements (if any) are of the proper rating and are suitable for the application. If in doubt, consult your Siemens representative.

Inspection

The following areas should be inspected after a fault has occurred:

Enclosures

External evidence of enclosure deformation usually is indicative of damage within. Extensive damage will require replacement of the enclosure parts and the enclosed equipment. Insure that door mounted equipment and safety interlocks function properly. Verify that hinge and latch integrity is maintained.

Terminals and Internal Conductors

Replace all damaged parts which show evidence of discoloration, melting or arcing damage. Special attention should be paid to the stab (disconnect) fingers.

Contactors

Refer to the instruction manual for the vacuum contactors. Manual SGIM-9088 applies to the type 96H3 and 97H3 contactors, while manual MVC-9098 applies to type 96H6 contactors.

Overload Relays

The complete overload relay must be replaced if burnout of the heater element has occurred. Any indication of an arc striking or burning the overload relay also requires replacement.

If there is no visual indication of damage that would require replacement, contact operation must be verified by electrically or mechanically tripping and resetting the overload relay.

Fuse Holders

Replace fuse holders if the insulation mounts, barriers, or fuse clips show signs of damage, deterioration, heating, distortion or looseness.

Fuses

Always replace all three fuses in a three phase circuit even though only one or two are open circuited since internal damage suffered by fuses not replaced could result in nuisance shut-down later.

Perform the "Pre-Energization Check" procedures detailed in this manual before restoring the equipment to service.

Troubleshooting

General

In the event that operating problems are encountered, use the following troubleshooting chart **Table 11** to isolate the cause of the problem and find the remedy. If the corrective action given in the chart fails to correct the difficulty, consult your Siemens representative.

The following information is required if it is necessary to contact Siemens relative to the equipment problem.

1. Manufacturer's order number (and part number, if available).
2. Nameplate data on contactor or controller.
3. Duty cycle and any details of operation.
4. Length of time in service and approximate total number of operations
5. Voltage, current and frequency.
6. Description of any problem.
7. Any other pertinent information, such as drawing, layout and schematic number.

Table 11. Troubleshooting Chart

Problem	Possible Causes	Remedy
Doors will not close or are out of alignment	Enclosure is not bolted down tightly on perfectly level surface. Enclosure sprung out of shape. Door hinges not properly adjusted.	Using level, add shims as necessary, and tighten anchoring bolts. Straighten or repair cubicle. Remove door hinges. Add or subtract shims as necessary.
Binding of racking or shutter mechanism or mechanical interlocks	Warpage or breakage of shutter mechanism or housing components. Mechanism components are binding. Rough handling during transportation or installation.	Replace shutter mechanism or housing component as required to insure smooth operation. See maintenance section on adjusting racking, shutter and interlock mechanism. Adjust mechanism and replace broken parts.
Contactors will not close	Control circuit or main fuse blown. Incoming power line not energized. Line switch interlock (LSI) is not adjusted properly. Main contactor coil Master Relay (MR) defective. Control power transformer defective. Overload relay tripped or defective. Defective rectifier. Selector switch (RUN-TEST) is not in proper position. Missing jumpers, loose connections, remote connections, etc.	Inspect fuses, replace if blown. Close feeder circuit breaker or tie switch. Adjust per instructions in the maintenance section. Check magnet operation, replace coil as necessary. Check and replace if defective. Check and replace if necessary. Check and replace if necessary. Check rectifier and replace if necessary. Switch should be in the "RUN" position. Check wiring diagram carefully to make sure that all external or alternate connections have been made satisfactorily. This is especially true where remote protective or control devices are used.
Contactors chatter	Loose connection in control circuit Defective master relay. Defective coil or drive board High Altitude Low control voltage	Tighten connections in control circuit. Check relay, replace if necessary. Check main coil and rectifier, replace if necessary. Consult Siemens Check line voltage.

Troubleshooting

Table 11. Troubleshooting Chart (continued)

Problem	Possible Causes	Remedy
Overload relays trip during starting or soon after motor is up to speed	<p>Motor being started too frequently at close intervals.</p> <p>Motor overloaded.</p> <p>Excessive motor acceleration time.</p> <p>Low line voltage.</p> <p>Overload relay not adjusted to motor capabilities.</p> <p>Incorrect relay or relay set incorrectly.</p> <p>Relays set incorrectly.</p>	<p>Jogging and starting operations must be limited to capabilities of the motor. Check starting limitations in motor instruction manual before repeated starts.</p> <p>Limit starting load and running load to motor capabilities.</p> <p>The starting of high inertia loads may not permit the use of standard overload relay applications. For accelerating times of 10 seconds or more, special overload relay bypass devices and circuits would usually be required. Contact the factory regarding such problems and supply complete data on locked-rotor starting current and total accelerating time under maximum load conditions.</p> <p>Line voltage should be maintained between +/- 10% of motor nameplate voltage.</p> <p>Adjust relay setting in accordance with instructions for the overload relay. Adjustment should correspond to thermal rating of the motor, including temperature rise, duty and service factor.</p> <p>Contact factory.</p> <p>Set in accordance with relay instructions.</p>
Overload relays fail to trip on overload current	<p>Incorrect relay or relay set incorrectly.</p> <p>Relay tripping mechanism jammed.</p> <p>Current transformers with improper ratio or with short-circuited secondary terminals.</p>	<p>Check relay selection and adjustment per overload relay instructions.</p> <p>Replace relay.</p> <p>Current transformers must have a step-down ratio to correspond to full load motor current and relay selection. Protective jumpers may be provided at current transformer secondary terminals or on terminal block connections to guard against open transformer secondary circuit, and jumpers must be removed before placing equipment in operation.</p>

Troubleshooting

Table 11. Troubleshooting Chart (continued)

Problem	Possible Causes	Remedy
Blowing of motor power fuses	<p>Short circuit on the load side of the motor fuses.</p> <p>Jogging or too frequent starting.</p>	<p>Use megger and other test instruments to locate fault and correct.</p> <p>If one fuse blows, always replace all three fuses. When one fuse blows, there is often internal damage to the unblown fuses.</p> <p>On frequent starting, fuses accumulate abnormal heat and cool more slowly than do overload relays. Since fuses more closely follow cooling and heating of motor windings, successive starting operations must be limited to the safe capacity of the motor to prevent fuse blowing from this cause. Check size rating on fuse nameplate against data label in medium voltage compartment. All three fuses must agree.</p> <p>Fuses are selected on the basis of motor full load current, locked-rotor current and starting time. Approximate sizes can be determined by referring to Figure 18, in the "General Description" section of this manual.</p> <p>Fuses internally damaged because of improper handling. Motor power fuses are made up of multiple strands of fine silver ribbon which may be broken if fuses are dropped or roughly handled. Several individual strands can be broken without the trip target indicating a blown fuse. Handle fuses carefully, installing them in clips on the top of the vacuum contactor with the indicator toward the front.</p>
Blowing of primary control transformer fuses	<p>Shorted primary winding in control transformer.</p> <p>Fuse may be "open" due to rough handling before installing.</p> <p>Secondary fuses not properly coordinated</p>	<p>Replace or repair transformer.</p> <p>Replace fuse.</p> <p>Melting characteristics of secondary fuse should not intersect melting characteristic of primary fuse. Rating of standard NEC fuse should not exceed twice the secondary current rating.</p>
Blowing of secondary control transformer fuses	<p>Abnormal current or short circuit in control.</p>	<p>Check for faulty operation of economizing relay, shorted magnet coils, shorted rectifiers, grounds, loose or bent connections, mechanical binding in relay and contactor mechanisms, excessive operations and incorrect secondary terminal connections.</p>

www.ElectricalPartManuals.com