

Control Modes

The MICROMASTER has four modes of operation:

Linear voltage/frequency (410, 420, 440)

Quadratic voltage/frequency (410, 420, 440)

Flux Current Control (FCC) (440)

Sensorless vector frequency control (440)

Closed loop vector control (440 with encoder option card)

Linear Voltage/Frequency

The MICROMASTER can operate utilizing a standard V/Hz curve. Using a 460 VAC, 60 Hz motor as an example, constant volts per hertz is supplied to the motor at any frequency between 0 and 60 Hz. This is the simplest type of control and is suitable for general purpose applications.

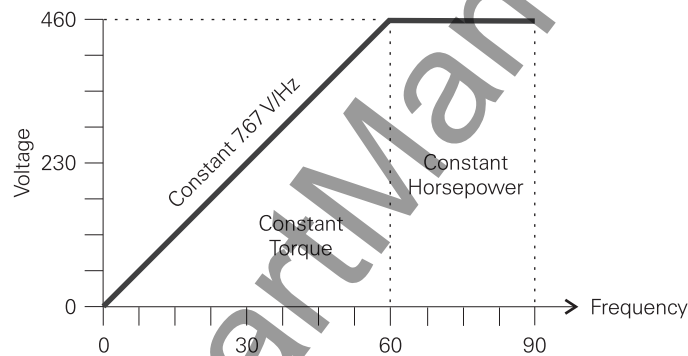

Quadratic Operation

A second mode of operation is referred to as a quadratic voltage/frequency curve. This mode provides a V/Hz curve that matches the torque requirements of simple fan and pump applications.

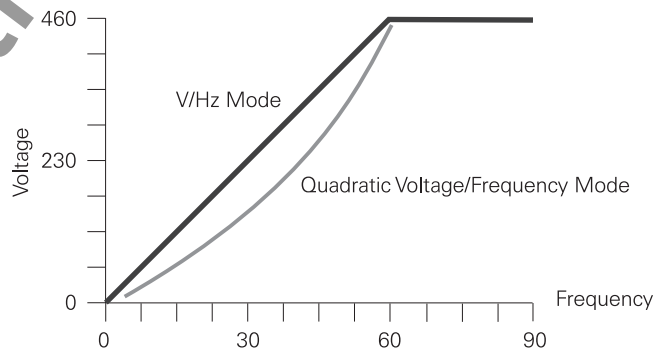

Flux Current Control

Stator current (I_s) is made up of active and reactive current. The reactive current component of stator current produces the rotating magnetic field. The active current produces work. Motor nameplate data is entered into the drive. The drive estimates motor magnetic flux based on the measured reactive stator current and the entered nameplate data. Proprietary internal computer algorithms attempt to keep the estimated magnetic flux constant.

If the motor nameplate information has been correctly entered and the drive properly set up, the flux current control mode will usually provide better dynamic performance than simple V/Hz control. Flux current control automatically adapts the drive output to the load. The motor is always operated at optimum efficiency. Speed remains reliably constant even under varying load conditions.

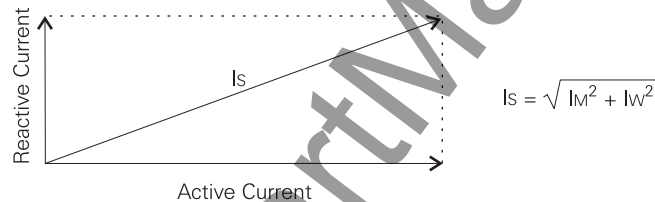

Sensorless Vector Control

In the past, the dynamic response of a DC motor was generally considered significantly better than an AC motor. An AC motor, however, is less expensive and requires less maintenance than a DC motor. Using a complex mathematical motor model and proprietary internal computer algorithms vector control is able to exert the necessary control over an AC motor so that its performance is equal to that of a DC motor. Vector control, flux vector, and field orientation are terms that describe this specialized control technique of AC drives.

Vector control systems facilitate independent control of flux producing and torque producing elements in an induction motor. Sensorless vector control calculates rotor speed based on the motor model, calculated CEMF, inverter output voltage, and inverter output current. This results in improved dynamic performance compared to other control methods.

When motor speed is calculated at very low speeds, based on a small CEMF and known corrections for stator resistance, slight variations in stator resistance and other parameters will have an effect on speed calculation. This makes vector control without a tachometer impractical below a few hertz.

Siemens sensorless vector control drives do operate smoothly to low speed. Sensorless vector control drives will produce full torque below a few hertz, and 150% or more torque at all speeds.

There are some complicated techniques used to accomplish this low speed torque with sensorless vector control. Expert setup and commissioning may be required to achieve desired operation at low speed.

Parameters for static torque, flux adaptation, slip compensation, and other concepts are complex and beyond the scope of this course.

Single-Quadrant Operation

In the speed-torque chart there are four quadrants according to direction of rotation and direction of torque. A single-quadrant drive operates only in quadrants I or III (shaded area). Quadrant I is forward motoring or driving (CW). Quadrant III is reverse motoring or driving (CCW). Reverse motoring is achieved by reversing the direction of the rotating magnetic field. Motor torque is developed in the positive direction to drive the connected load at a desired speed (N). This is similar to driving a car forward on a flat surface from standstill to a desired speed. It takes more forward or motoring torque to accelerate the car from zero to the desired speed. Once the car has reached the desired speed your foot can be let off the accelerator a little. When the car comes to an incline a little more gas, controlled by the accelerator, maintains speed.

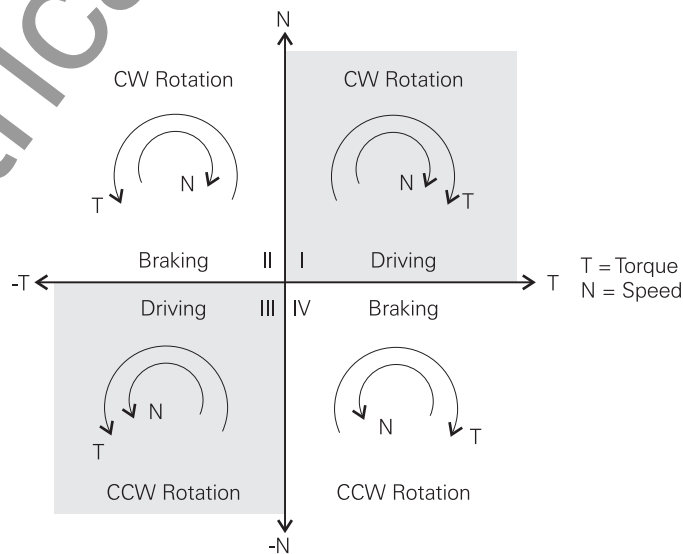

Coast-to-Stop

To stop an AC motor in single-quadrant operation voltage and frequency can simply be removed and the motor allowed to coast to a stop. This is similar to putting a car in neutral, turning off the ignition and allowing the car to coast to a stop.

Controlled Deceleration

Another way is to use a controlled deceleration. Voltage and frequency are reduced gradually until the motor is at stop. This would be similar to slowly removing your foot from the accelerator of a car. The amount of time required to stop a motor depends on the inertia of the motor and connected load. The more inertia the longer it will take to stop.

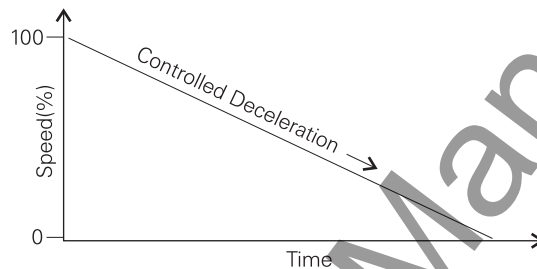

DC Injection Braking

The DC injection braking mode stops the rotating magnetic field and applies a constant DC voltage to the motor windings, helping stop the motor. Up to 250% of the motor's rated current can be applied. This is similar to removing your foot from the accelerator and applying the brakes to bring the car to a stop quickly.

Compound Braking

Compound braking uses a combination of the controlled deceleration ramp and DC injection braking. The drive monitors bus voltage during operation and triggers compound braking when the bus exceeds a set threshold point. As the motor decelerates to a stop a DC voltage is periodically applied to the motor windings. The excess energy on the bus is dissipated in the motor windings. This is similar to alternately applying the brakes to slow a car, then allowing the mechanical inertia of the engine to slow the vehicle until the car is brought to a stop.

Four-Quadrant Operation

The dynamics of certain loads may require four-quadrant operation. When equipped with an optional braking resistor the Siemens MICROMASTER is capable of four-quadrant operation. Torque will always act to cause the rotor to run towards synchronous speed. If the synchronous speed is suddenly reduced, negative torque is developed in the motor. The motor acts like a generator by converting mechanical power from the shaft into electrical power which is returned to the AC drive. This is similar to driving a car downhill. The car's engine will act as a brake. Braking occurs in quadrants II and IV.

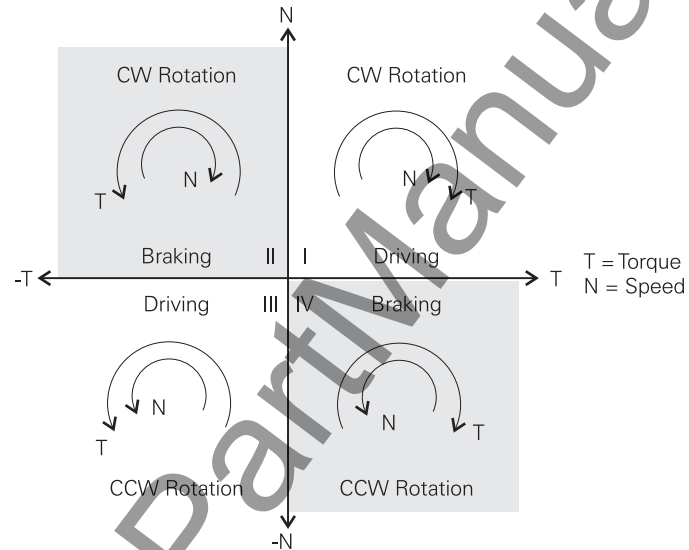

Pulsed Resistor Braking

In order for an AC drive to operate in quadrant II or IV, a means must exist to deal with the electrical energy returned to the drive by the motor. Electrical energy returned by the motor can cause voltage in the DC link to become excessively high when added to existing supply voltage. Various drive components can be damaged by this excessive voltage. An optional braking resistor is available for the Siemens MICROMASTER. The braking resistor is connected to terminals B+ and B-. The braking resistor is added and removed from the circuit by an IGBT. Energy returned by the motor is seen on the DC link. When the DC link reaches a predetermined limit the IGBT is switched on by the control logic. The resistor is placed across the DC link. Excess energy is dissipated by the resistor, reducing bus voltage. When DC link voltage is reduced to a safe level the IGBT is switched off, removing the resistor from the DC link. This is referred to as pulsed resistor braking. This process allows the motor to act as a brake, slowing the connected load quickly.

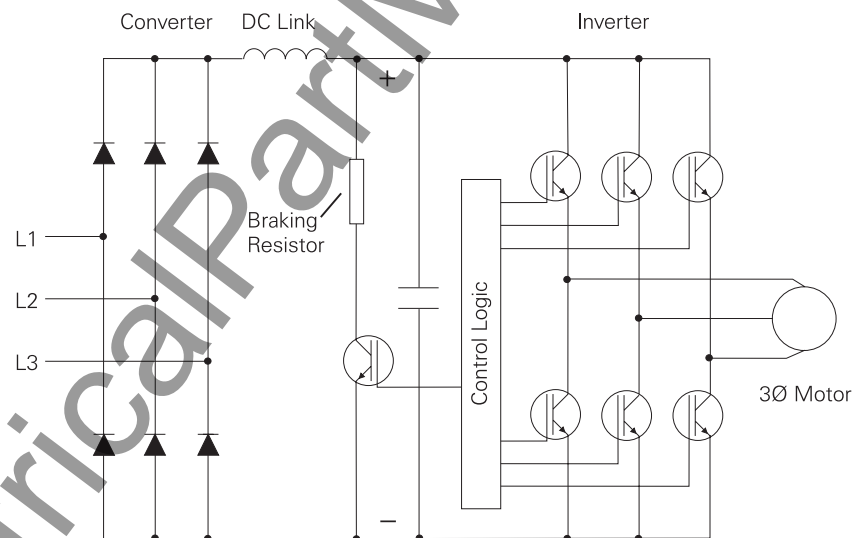

Distance to Motor

All motor cables have line-to-line and line-to-ground capacitance. The longer the cable, the greater the capacitance. Some types of cables, such as shielded cable or cables in metal conduit, have greater capacitance. Spikes occur on the output of all PWM drives because of the charging current of the cable capacitance. Higher voltage (460 VAC) and higher capacitance (long cables) result in higher current spikes. Voltage spikes caused by long cable lengths can potentially shorten the life of the inverter and the motor.

The maximum distance between a motor and the MICROMASTER, when unshielded cable is used, is 100 meters (328 feet). If shielded cable is used, or if cable is run through a metal conduit, the maximum distance is 50 meters (164 feet). When considering an application where distance may be a problem, contact your local Siemens representative.

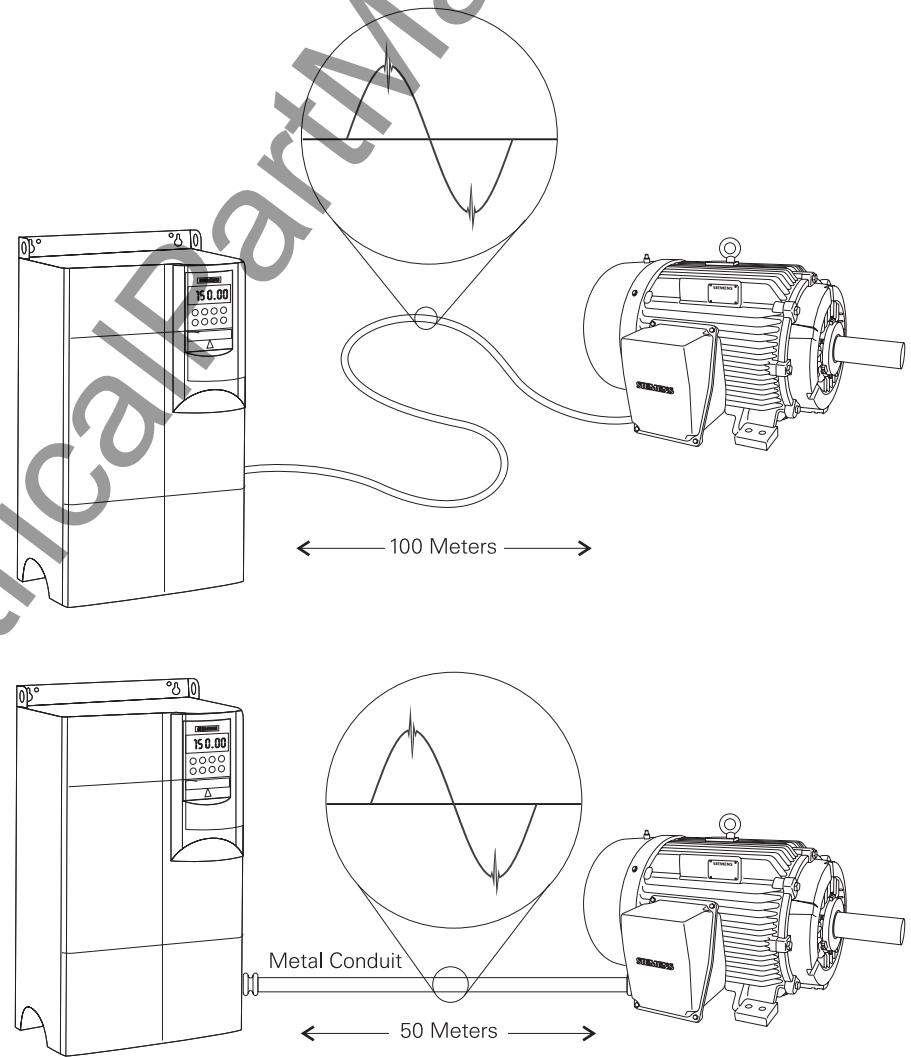

Enclosures

The National Electrical Manufacturers Association (NEMA) has specified standards for equipment enclosures. The MICROMASTER is supplied in a protected chassis and a NEMA Type 1 enclosure.

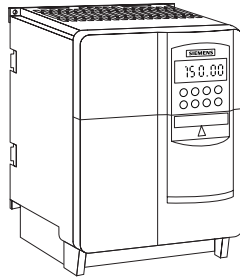

Ambient Temperature

The MICROMASTER is rated for operation in an ambient temperature of 0 to 40° C for variable torque drives and 0 to 50° C for constant torque drives. The drive must be derated to operate at higher ambient temperatures.

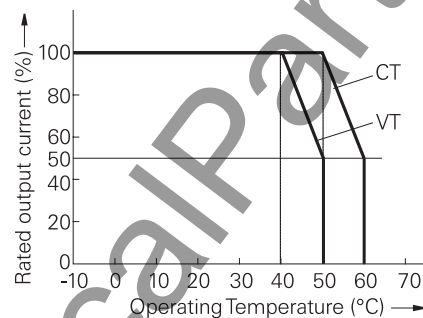

Elevation

The MICROMASTER is rated for operation below 1000 meters (3300 feet). At higher elevations the air is thinner, consequently the drive can't dissipate heat as effectively and the drive must be derated. In addition, above 2000 meters (6600 feet) the supply voltage must be reduced.

Permissible output current in % of rated output current

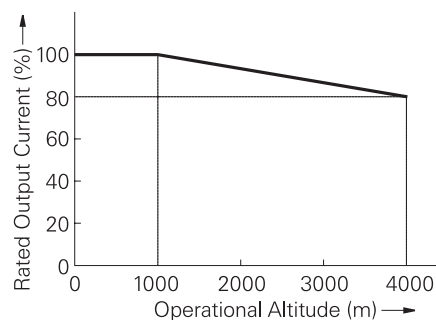

Permissible mains voltage in % of the max. possible mains voltage

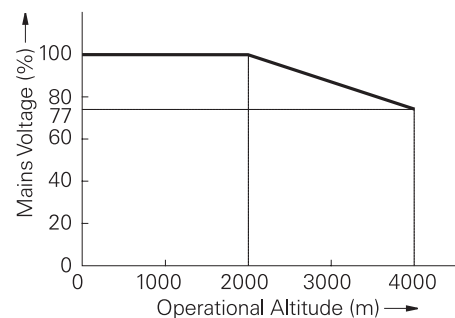

Review 4

1. The _____ key on the BOP and AOP is used to toggle between a parameter number and value.
2. The maximum acceleration/deceleration ramp time on the MICROMASTER is _____ seconds.
3. A mode of operation which provides a V/Hz curve that matches the torque requirements of simple fan and pump applications is _____ .
 - a. Linear voltage/frequency
 - b. Quadratic voltage/frequency
 - c. FCC
 - d. Sensorless vector frequency
4. _____ uses internal computer algorithms to control an AC motor so that its performance is equal to that of DC motor.
 - a. Linear voltage/frequency
 - b. Quadratic voltage/frequency
 - c. FCC
 - d. Sensorless vector control
5. Forward regeneration occurs in quadrant _____ .
6. The maximum distance between a MICROMASTER and a motor is _____ meters when unshielded cable is used.
7. 380 VAC to 480 VAC, Frame size B of the MICRAMASTER 420 is available in power ratings from _____ to _____ HP.

Siemens MASTERDRIVE

Siemens MASTERDRIVES provide an excellent solution for industrial applications worldwide. In addition to standard air cooled units, water cooled versions can be used in areas with high ambient temperature or where external air cooling is unavailable. MASTERDRIVES can be used for variable-speed control on motors rated from 1 to 5,000 HP. MASTERDRIVES are available for all major worldwide 3-phase supply voltages: 380-460, 500-575, and 660-690 volts. The Siemens MASTERDRIVES can also be referred to by a model series number, 6SE70.

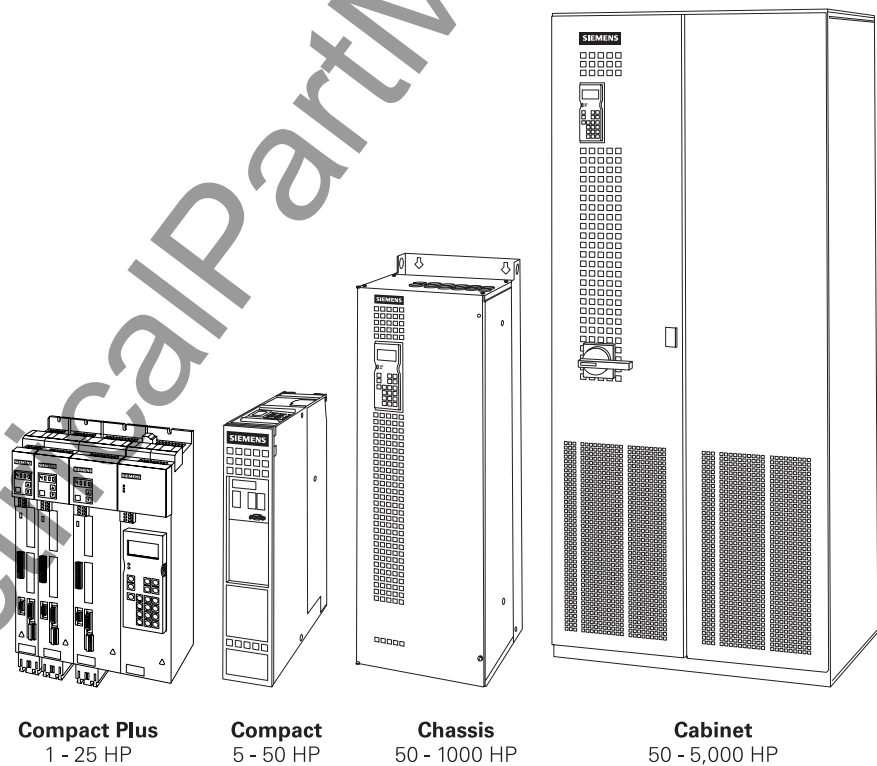

Versions

There are two versions of the MASTERDRIVES product: vector control (VC) and motion control (MC).

Vector Control (VC)

One mode of operation in the MASTERDRIVES is vector control (VC), which is the focus of this part of the course. In the past, the dynamic response of a DC motor was generally considered significantly better than an AC motor. An AC motor, however, is less expensive and requires less maintenance than a DC motor. Using a complex mathematical motor model and proprietary internal computer algorithms vector control is able to exert the necessary control over an AC motor so that its performance is equal to that of a DC motor. Vector control, flux vector, and field orientation are terms that describe this specialized control technique of AC drives.

Vector control drives have 4-quadrant operation and control torque and speed continuously through zero speed, and can hold a motor stationary against an applied torque. Speed control is exact, even with varying loads. Speed control reaction time is ≤ 45 ms without tach feedback, and ≤ 20 ms with tach feedback. Maximum torque is available up to base speed. Torque control reaction time is ≤ 10 ms in torque control with feedback.

Motion Control (MC)

A second mode of operation available on the MASTERDRIVES is motion control (MC). Servo drives are designed to operate with a specific motor and are designed to achieve speed precision and fast response to a speed change. Servo applications typically have rapid start-stop cycles, require zero speed holding torque and high accelerating torque from zero speed, and are used positioning applications. In a packaging machine, for example, material may have to start and stop at various positions along a conveyor system.

The STEP 2000 course, **Basics of General Motion Control**, provides more information on the Siemens motion control (MC) drive.

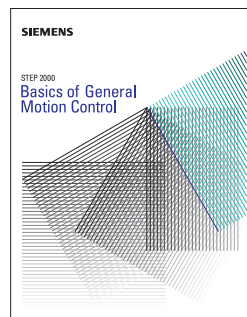

AC - AC (Converter)

The terms AC - AC and DC - AC refers to hardware methods of configuring MASTERDRIVES. AC - AC in the MASTERDRIVE VC family refers to a single drive, connected to an AC source, controlling an AC motor, an AC motor with a tach, or multimotor applications.

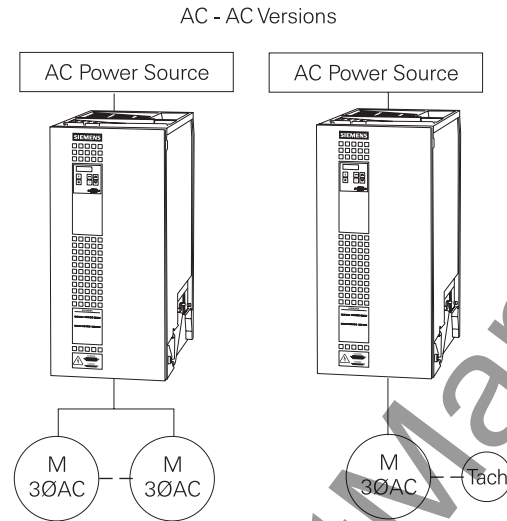

DC - AC (Inverter)

The MASTERDRIVE VC can also be configured so that a common DC bus supplies power to several AC inverters. Common DC bus systems also allow single and multimotor combinations. This is referred to as DC-AC. An advantage to this system is that energy regenerated by one inverter can be consumed by another inverter on the same bus.

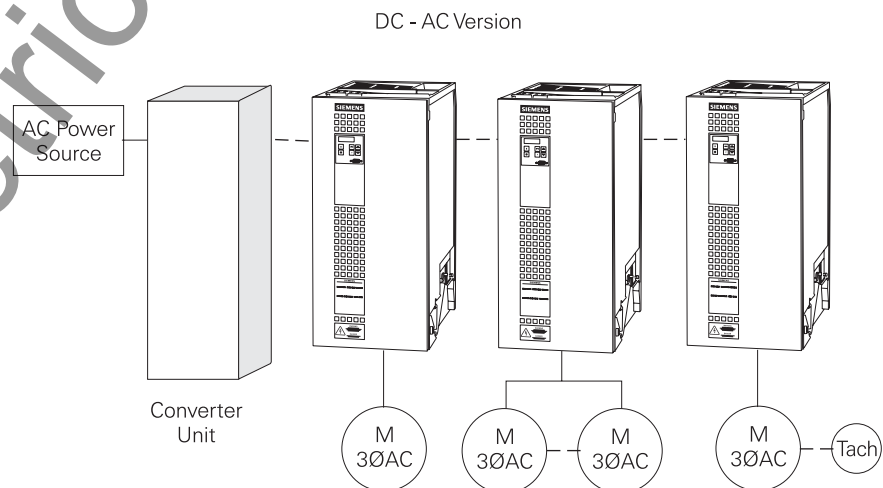

Braking Choices

The dynamics of certain loads require four-quadrant operation. Torque will always act to cause the rotor to run towards synchronous speed. If the synchronous speed is suddenly reduced, negative torque is developed in the motor. This could occur, for example when a stop command is initiated and the drive tries to slow down to bring the motor to a stop. The motor acts like a generator by converting mechanical power from the shaft into electrical power which is returned to the AC Drive. This is known as regeneration, and helps slow the motor. Braking occurs in quadrants II and IV. When equipped with an optional braking unit, Siemens MASTERDRIVES are capable of four-quadrant operation.

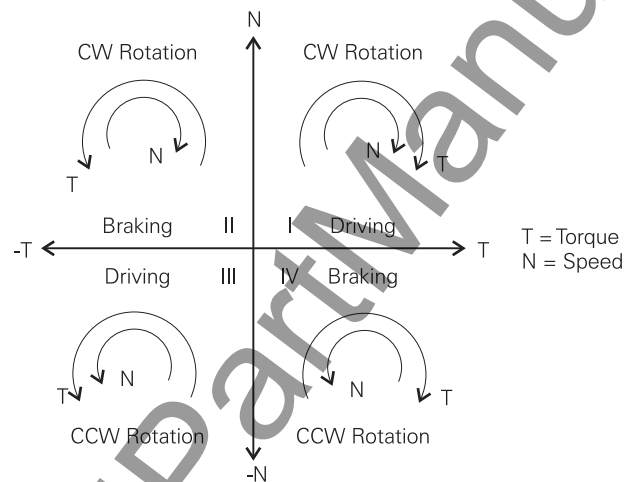

One method of dealing with negative torque and the current it produces is controlled deceleration. Voltage and frequency is reduced gradually until the motor is at stop. This would be similar to slowly removing your foot from the accelerator of a car. Many applications, however, require the motor to stop quicker, and the drive must be capable of handling the excess energy produced by motor when this is done.

Rectifier Regenerative Front End

Another method of dealing with excessive regeneration is with a rectifier regenerative front end. Diodes in the converter section are replaced with SCRs and a second regen bridge is added. An SCR functions similarly to a diode rectifier, except that it has a gate lead, which is used to turn the SCR on. This allows the control logic to control when the converter bridge and regen bridge are turned on.

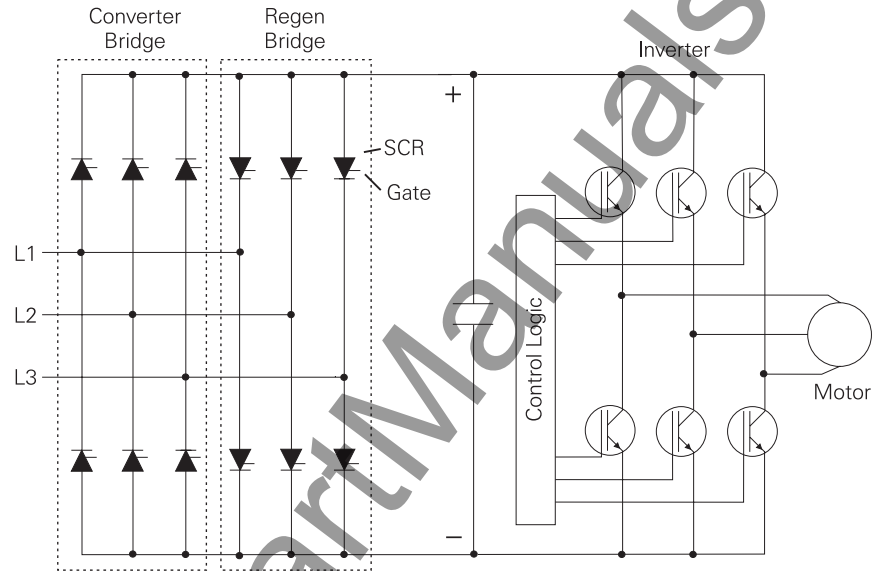

A simplified block diagram provides a clearer view of the regen process. When the motor needs motoring energy to accelerate or maintain speed against the inertia of a load, the converter bridge is turned on. When the motor is in the regenerative mode, it acts like a generator, supplying electrical energy back to the DC link. When the DC link voltage reaches a predetermined level the motoring SCRs are switched off and the regen (generating) SCRs are switched on.

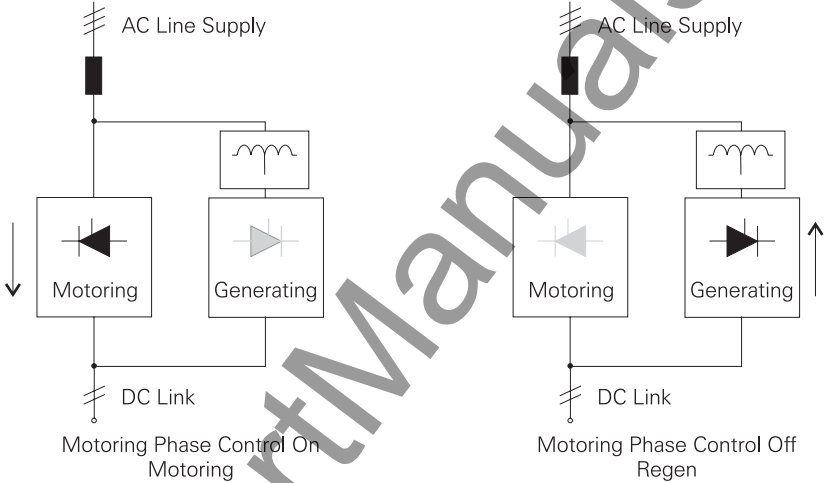

This allows the excess energy to be returned to the AC line in the form of AC current.

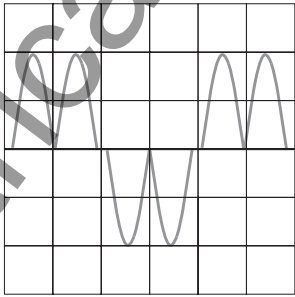

Current Returned to AC Line During Regeneration

ACTIVE FRONT END

An ACTIVE FRONT END (AFE) is another option available to control regenerative voltage. With this option the diodes in the converter bridge are replaced with IGBT modules and a Clean Power Filter. The IGBT, controlled by control logic, operates in both motoring and regenerating modes.

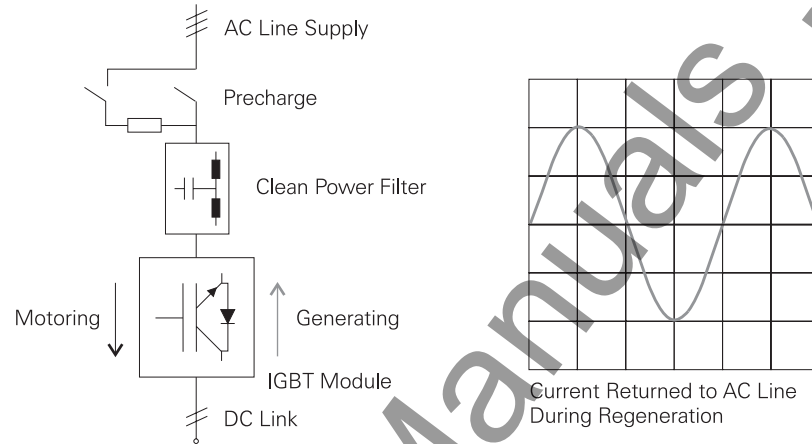

Harmonics are created by electronic circuits, such as the non-linear loads of adjustable speed drives. Harmonics can cause problems to connected loads. The base frequency is said to be the fundamental frequency or first harmonic. Additional harmonics that are superimposed on the fundamental frequency are usually whole number multiples of the first harmonic. The fifth harmonic of a 60 Hz power supply, for example, is 300 Hz (60×5).

A distinct advantage of Siemens MASTERDRIVES equipped with AFE and a Clean Power Filter is they are optimally harmonized with each other to eliminate harmonics and provide a clean power supply. In addition, the Siemens AFE allows for capacitive KVAR production which effectively compensates for other inductive loads in an industrial plant. This helps reduce the overall utility bill.

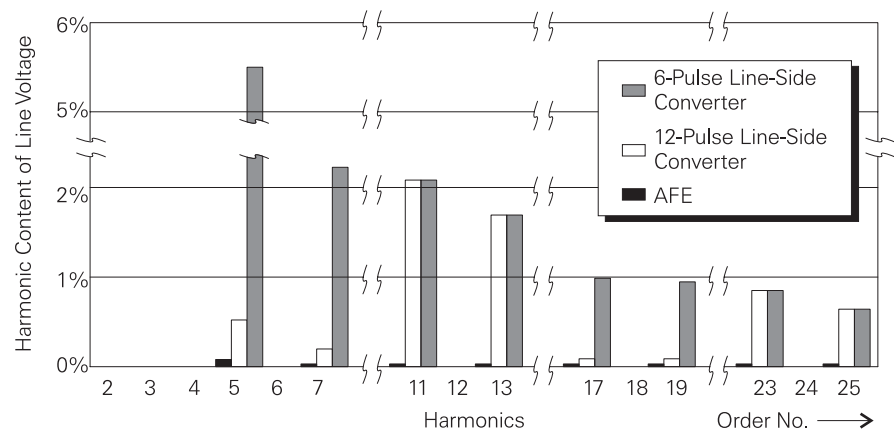

Programming and Operating Sources

Access is gained to the MASTERDRIVE VC for programming operating parameters and motion profiles from the following sources:

- Operator Control Panel (OP1S)
- Parameterization Unit (PMU)
- Various Serial Interfaces
- PC Based Software (Simovis)

PMU, OP1S, and HMI Panels

The MASTERDRIVE can be programmed and operated by the PMU, OP1S, or other SIMATIC HMI device such as the TP170A (shown), TP170B, OP27, or MP370.

Parameters, such as ramp times, minimum and maximum frequencies, and modes of operation are easily set. The changeover key ("P") toggles the display between a parameter number and the value of the parameter. The up and down pushbuttons scroll through parameters and are used to select a parameter value, once the "P" key sets the parameter. The OP1S has a numbered key pad for direct entry. The TP170A uses a touch-sensitive screen for control and monitoring.

Serial communication is available through RS232 or RS485 connections. The OP1S can be mounted directly on the PMU or up to 200 meters away. An additional 5 volt power supply is required for remote operation over 5 meters. The TP170A is powered from the drive and standard PROFIBUS connections.

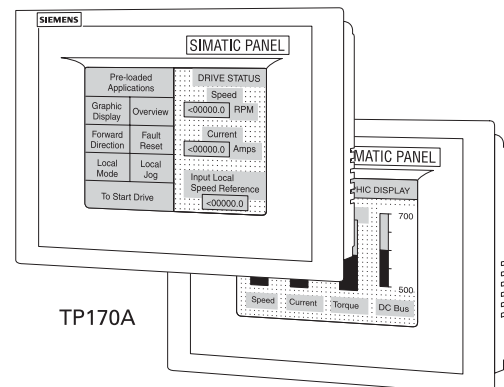
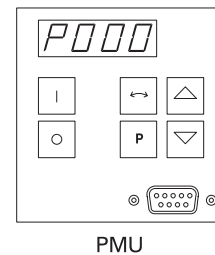
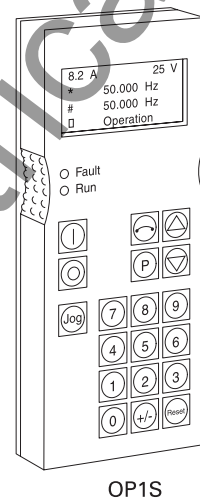

MASTERDRIVE Compact, Chassis, and Cabinet Units

Compact Drive

The compact drive is available with ratings from 3 to 50 HP (5.6 to 72 amps) at 460 VAC. The following drawing represents is a layout illustration of sizes A, B, and C. Size D is packaged in a larger form. The main power supply (380 - 480 VAC) is connected to X1. The DC link is available at X3. The servomotor is connected to X2.

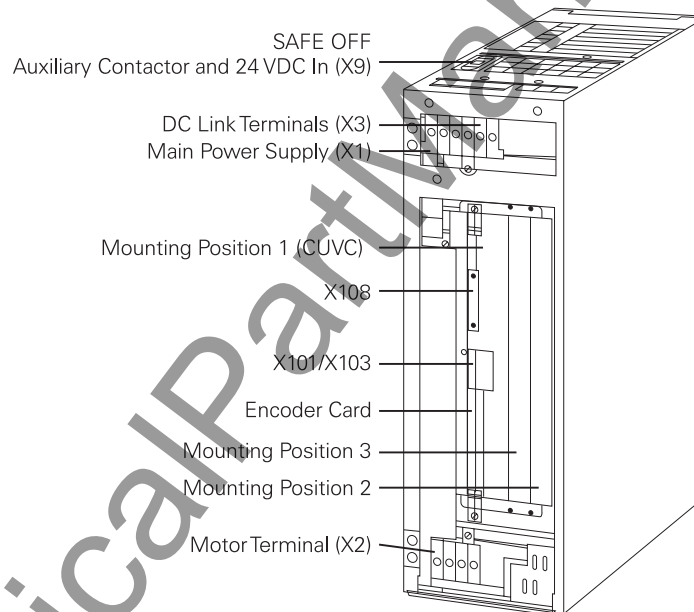

Chassis Drive

The chassis drive uses an open architecture for cabinet mounting. Chassis drives are available with ratings from 60 to 500 HP (83.7 to 590 amps) at 460 VAC. The following drawing illustrates sizes E and F. Size G is packaged in a larger form.

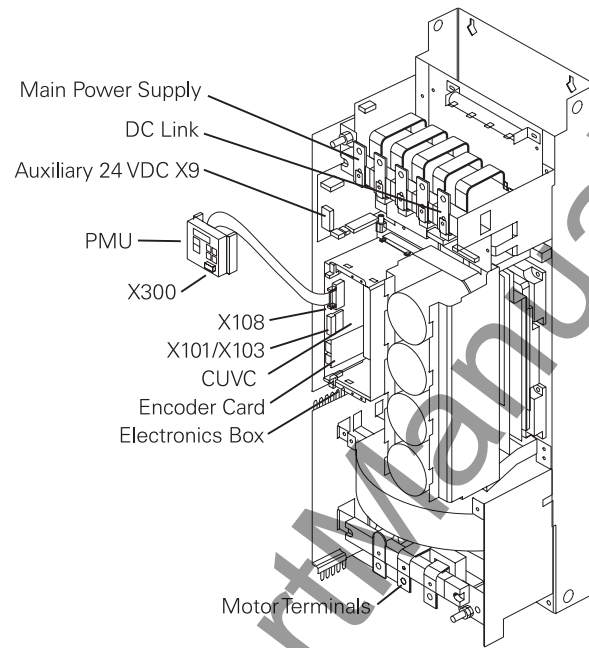

Cabinet Units

Cabinet units, referred to as 6SE71 for IEC standards or 6SE72 for NEMA standards, are ready-wired complete units for single and multimotor applications. All components are accessible from the front of the cabinet. Cabinet units are available with ratings from 50 to 10,000 HP.

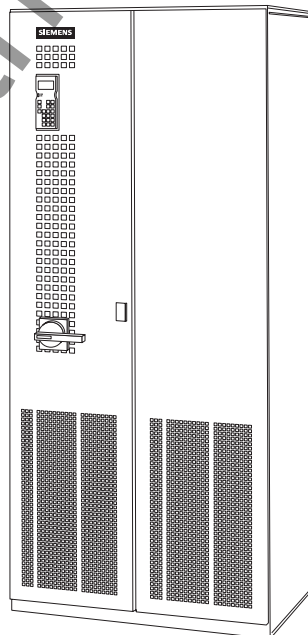

IEC and NEMA Protection

Depending on the size of the unit, Siemens MASTERDRIVES are available in a variety of enclosures. In addition to the basic MASTERDRIVE 6SE70 enclosures, drives designated 6SE71 are built to International Electrotechnical Commission (IEC) standards. Drive enclosures designated 6SE72 are built to National Electrical Manufacturers Association (NEMA) standards. IEC and NEMA enclosure standards provide various degrees of protection to personnel and equipment.

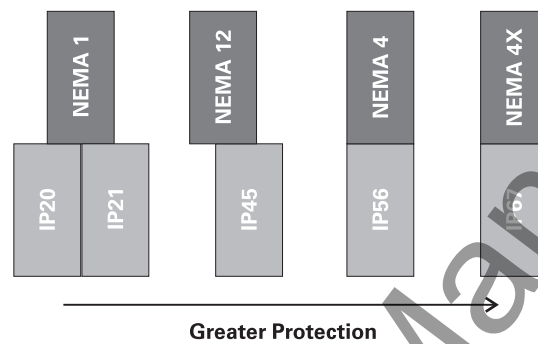

IEC Standards

The IEC system of classification consists of the letters IP followed by two numbers. The first number indicates the degree of protection provided by the enclosure with respect to persons and solid objects entering the enclosure. The second number indicates the degree of protection against the ingress of water.

| 1st Number | Description |
|------------|--|
| 0 | Not Protected |
| 1 | Protected Against Objects Greater than 50 mm |
| 2 | Protected Against Objects Greater than 12 mm |
| 3 | Protected Against Objects Greater than 2.5 mm |
| 4 | Protected Against Objects Greater than 1.0 mm |
| 5 | Protected Against Dust |
| 6 | Dust Tight |
| 2nd Number | Description |
| 0 | Not Protected |
| 1 | Protected Against Dripping Water |
| 2 | Protected Against Dripping Water when Tilted up to 15° |
| 3 | Protected Against Spraying Water |
| 4 | Protected Against Splashing Water |
| 5 | Protected Against Water Jets |
| 6 | Protected Against Heavy Seas |
| 7 | Protected Against the Effects of Immersion for Specific Time and Pressure |
| 8 | Protected Against Continuous Submersion Under Conditions Specified by the Manufacturer |

P Enclosures Available

MASTERDRIVES are available in the following IP enclosures:

| MASTERDRIVE | IP Ratings Available |
|-----------------------|--|
| Compact, Compact Plus | IP20 |
| Chassis | IP00, IP20 |
| Cabinet | IP20, IP21, IP23, IP24, IP43, Prepared for IP54 |

NEMA Standards

The National Electrical Manufacturers Association (NEMA) also designates, by means of a type number, environmental conditions an enclosure is suited for. MASTERDRIVES are available in NEMA 1, 4, and 12 enclosures.

| NEMA Type | Definition |
|-----------|---|
| 1 | Indoor use primarily to provide a degree of protection against limited amounts of falling dirt. |
| 4 | Indoor or outdoor use primarily to provide a degree of protection against windblown dust and rain, splashing water, hose-directed water, and damage from external ice formation. |
| 4X | Indoor or outdoor use primarily to provide a degree of protection against corrosion, windblown dust and rain, splashing water, hose-directed water, and damage from external ice formation. |
| 12 | Indoor use primarily to provide a degree of protection against circulating dust, falling dirt, and dripping noncorrosive liquids. |

Electronics Box

The electronics box contains the CUVC and option boards. The CUVC board is plugged into slot 1. The CUVC board is the central electronic board for all AC-AC and DC-AC 6SE70 VC MASTERDRIVES. It has input and output connections for wiring the control devices of various functions such as start/stop pushbuttons and speed potentiometer. The CUVC board is self-optimizing and has comprehensive diagnostics.

Up to six boards can be installed in the electronics box. An LBA (Local Bus Adapter) is required if mounting positions 2 or 3 are needed. In addition, adapter boards (ADB) are necessary for Slots D and E, and F and G when utilizing the half-size option boards. Option boards are automatically recognized by the drive.

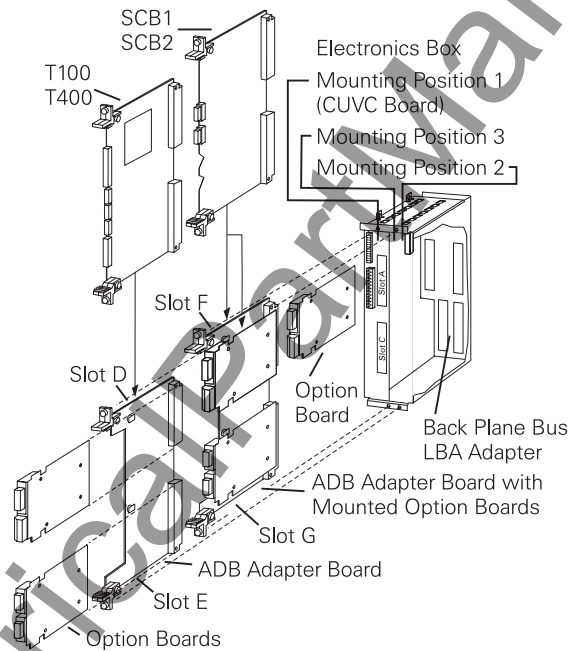

CUVC Control Board

The Siemens MASTERDRIVE can be programmed and operated from the terminal strip located on the CUVC board. The following drawing illustrates a typical terminal arrangement of the CUVC board used in the MASTERDRIVE VC. RS 485 serial communication is available on X101. Programmable binary outputs, used to indicate a condition of the drive, are available on X101. Binary inputs are also available. Starting/stopping the drive and selecting preset speeds are examples of possible binary input functions. The MASTERDRIVE accepts analog inputs (voltage or current) for speed control on X102. There are programmable analog outputs for meter indication. A motor temperature switch can be connected on X103 and is used to stop a drive in the event a motor becomes overheated. Connections are also available for a digital tach. Not all features are available on all versions. Consult detailed product literature for more information.

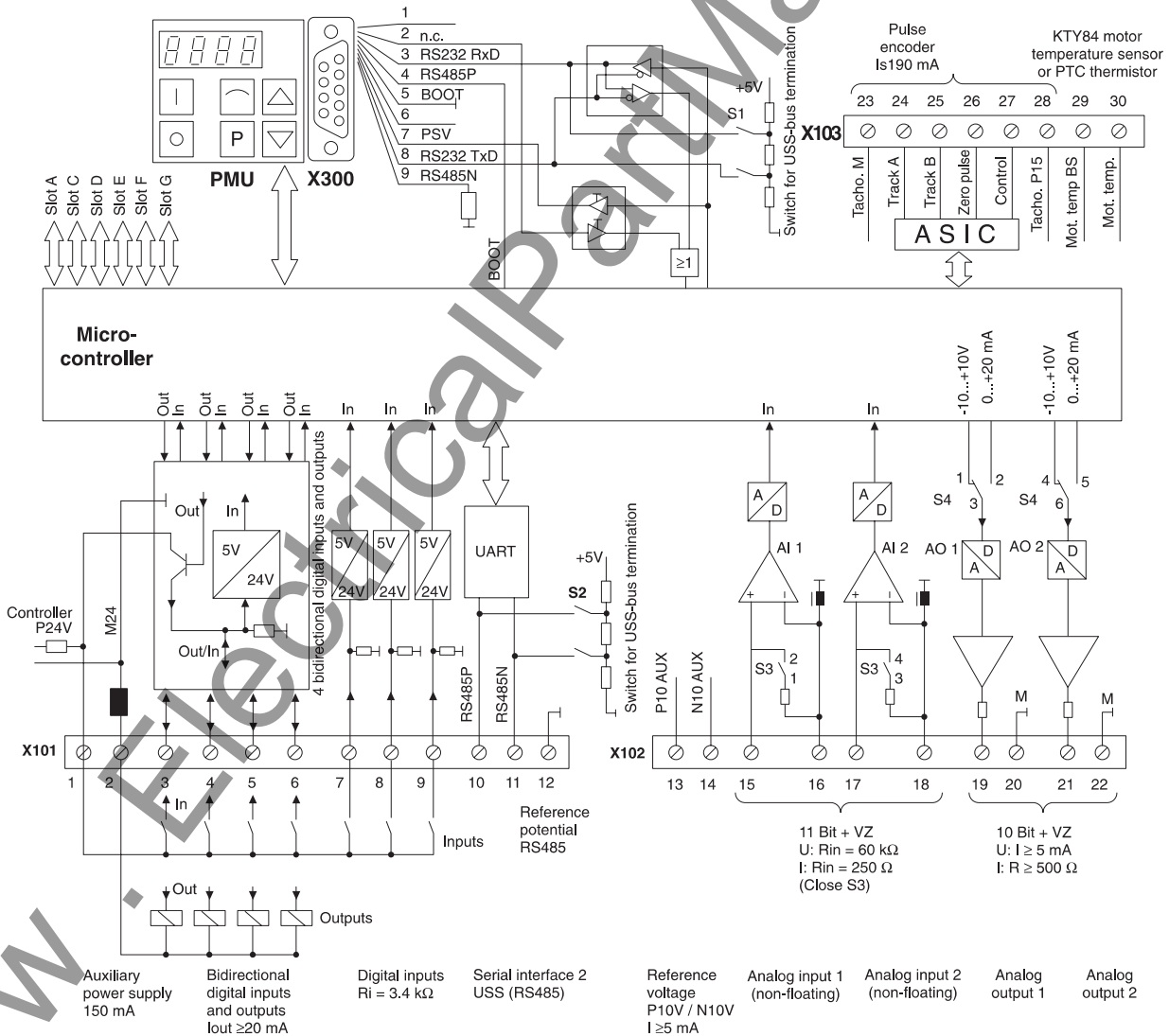

Communication Options

Communication option boards CBP2, SLB, SCB1, and SCB2 allow high speed communication through RS 485 wires or fiber-optic cables. Peer-to-peer communication allows data to be exchanged between drives and is available using serial communication boards SLB, SCB1, and SCB2, and technology boards T100, T300, and T400. PC and PLC communication is available with SCB2 (USS Protocol) and communication board CBP2 (PROFIBUS). Communication boards are also available to support CAN Bus and DEVICE NET.

The SLB board is used for peer-to-peer communication with other drives via SIMOLINK. SIMOLINK is a high speed (11 mbaud) fiber optic ring bus that allows various data to be passed from one drive to next.

Expansion Boards

Expansion boards are used to expand the number of digital and analog inputs and outputs. In addition to a 120 volt interface that is available, EB1 and EB2 are half-sized expansion boards that provide a number of additional I/O possibilities.

The EB1 board has three digital inputs and four bidirectional digital I/O. Bidirectional I/O can be configured as a digital input or output. One of the analog inputs is used as a voltage or current reference input. Two of the analog inputs can also be configured as digital inputs.

The EB2 board has two digital inputs, one analog input, and one analog output. In addition, the EB2 has four relay contacts. Three of the contacts are normally open (NO) and one of the contacts can be configured as normally open (NO) or normally closed (NC). A maximum of two half-sized EB boards can be used.

| I/O | EB1 | EB2 | 120 Volt Interface |
|-----------------------------|-----|-----|--------------------|
| Digital Inputs | 3 | 2 | 5 |
| Bidirectional Digital I/O | 4 | 0 | 0 |
| Analog Inputs | 3 | 1 | 0 |
| Analog Outputs | 2 | 1 | 0 |
| Relay Outputs | 0 | 4 | 3 |
| Input for 24 V Power Supply | 1 | 1 | 0 |

SCB1

In addition to peer-to-peer drive communication the SCB1 can interface with one or two SCI boards. SCI boards provide additional inputs and outputs for drive control. SCI1 has 10 binary inputs, 7 binary outputs, 3 analog inputs, and 3 analog outputs. SCI2 has 16 binary inputs and 12 binary outputs. Inputs and outputs on the SCI1 and SCI2 boards provide more isolation and electromagnetic noise immunity than the standard I/O on the CU boards. SCI1 or SCI2 boards should be used in applications where noise immunity is a concern. The SCB2 board does not interface with SCI boards.

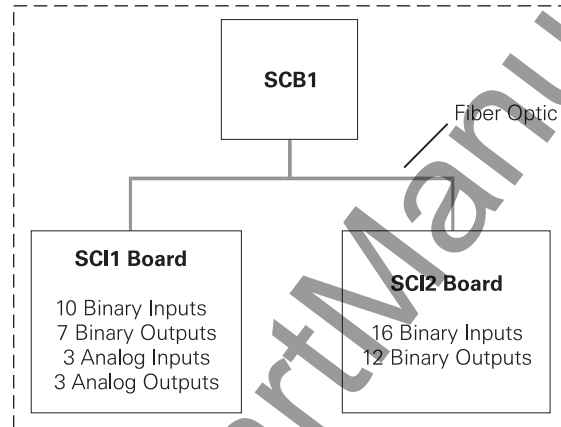

Encoder Interfaces

Digital tachometers (encoders) can be used to measure the actual speed of the motor. The Digital Tachometer Interface (DTI) is designed to be used with digital tachometers (encoders) that operate at a voltage other than 11-30 VDC. The DTI is also required for use with HTL encoders with inverted channel, floating HTL encoders, TTL encoders, or encoders with cables greater than 495 feet.

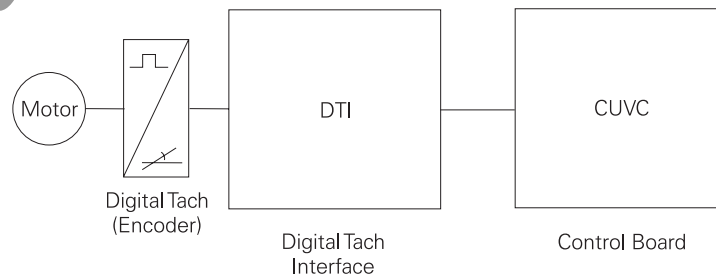

SBP Encoder Board

The SBP is an option that can be used to connect a second digital tach to the drive. This option can be used with differential or frequency control. The SBP can also be used to monitor an external encoder, such as might be connected to the driven machine.

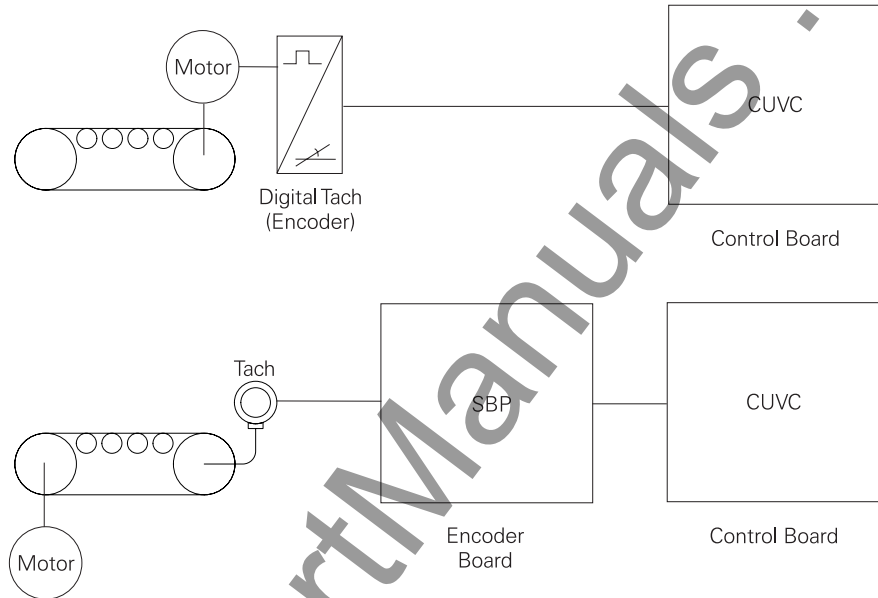

Analog Tachometers

Analog tachometers can also be used to measure the actual motor speed. Analog tachometers generate a DC voltage which is proportional to the speed. The voltage at maximum speed is a function of the actual tachometer, and generally lies between 10 V and 300 V. Closed loop speed control with an analog tach can be applied to a speed range from 1 RPM to 6000 RPM. An analog tach interface (ATI) board is used to connect an analog tach to the CUVC board.

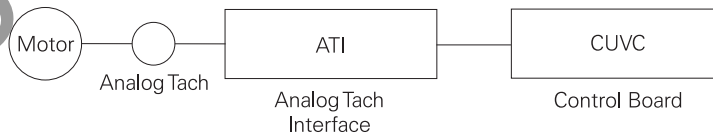

Technology Boards

Technology boards (T100, T400, and TSY) provide application specific control and enhancement. It should be noted that technology boards are not compatible with the optional 120 volt interface card. Technology option boards can be selected for sectional drives, synchronized running, winders, and positioning.

The TSY, for example, allows a drive to synchronize with a frequency. This is ideal for transferring motors across the line, or for synchronizing to the output of another drive for transferring the motor from one drive to another without shutting down a process.

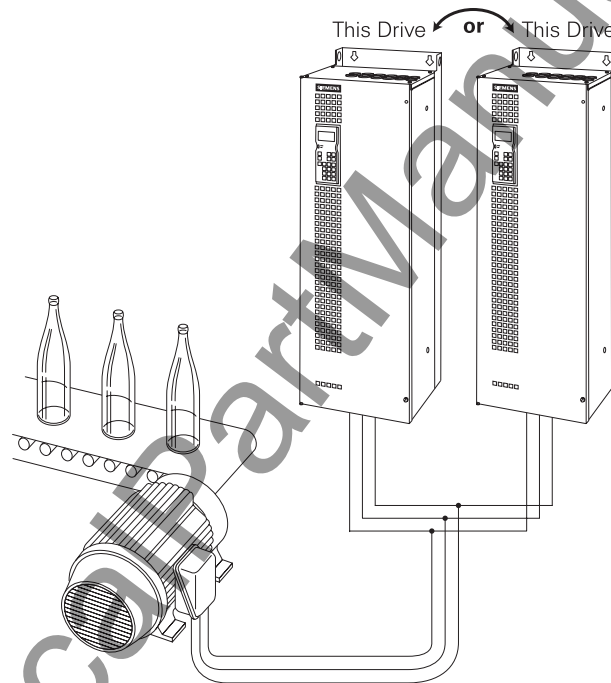

Sinewave Filter and dv/dt Filter

Distance from the drive to the motor must also be taken into consideration. All motor cables have line-to-line and line-to-ground capacitance. The longer the cable, the greater the capacitance. Some types of cables, shielded cable for example, have greater capacitance. Spikes occur on the output of all PWM drives because of the charging current of the cable capacitance. Higher voltage (460 VAC) and higher capacitance (long cables) result in higher current spikes. Voltage spikes caused by long cable lengths can potentially shorten the life of the motor. Spikes are generally the same value regardless of horsepower, therefore; smaller horsepower motors are more susceptible to damage.

Various devices are available for the MASTERDRIVE VC to protect the inverter and motor. A dv/dt filter, for example, limits motor voltage rise time (dv/dt) and maximum voltage spikes. This allows cable lengths greater than 300 meters. Another device designed to protect the motor from high voltage spikes is a sinewave filter. The sinewave filter generates a sinusoidal motor voltage and output current. It is very important to fully understand the chart, which shows the criteria for selecting the proper output reactor, dv/dt filter, or sinewave filter. Motor life will be shortened if the guidelines are ignored.

| 208 V to 230 V and 380 V to 500 V | | 325 V to 575 V | | | | | | | |
|---|-------------------|-----------------------------|-------------|--------------------|--------------------|--------------------|-----------------|-------------|-------|
| MASTER DRIVE VC | Output Reactor | Up to 50m | Motor | MASTER DRIVE VC | Sinewave Filter | Up to 50m | Motor | | |
| | | DIN VDE 0530 | | | | DIN VDE 0530 | | | |
| MASTER DRIVE VC | | Up to 50m | Motor | MASTER DRIVE VC | dv/dt Filter | Up to 50m | Motor | | |
| | | 1LA-5/1LA6- | | | | 1LA5-/1LA6- | | | |
| MASTER DRIVE VC | Output Reactor | 50 to 100m | Motor | MASTER DRIVE VC | Sinewave Filter | 50 to 100m | Motor | | |
| | | DIN VDE 0530 1LA-5/1LA6- | | | | DIN VDE 0530 | | | |
| MASTER DRIVE VC | | 50 to 100m | Motor | MASTER DRIVE VC | dv/dt Filter | 50 to 100m | Motor | | |
| | | 1LA-5/1LA6- | | | | 1LA5-/1LA6- | | | |
| MASTER DRIVE VC | Output Reactor | Output Reactor | 150 to 300m | Motor | MASTER DRIVE VC | Sinewave Filter | 150 to 300m | Motor | |
| | | DIN VDE 0530 1LA-5/1LA6- | | | | DIN VDE 0530 | | | |
| MASTER DRIVE VC | Output Reactor | dv/dt Filter | 150 to 300m | Motor | MASTER DRIVE VC | Output Reactor | dv/dt Filter | 150 to 300m | Motor |
| | | 1LA-5/1LA6- | | | | 1LA-5/1LA6- | | | |

Note: A sinewave filter will improve the current waveform but reduces RMS voltage by 20%. Refer to Siemens VC product catalog #DRMS-02051 or contact a Siemens sales representative for assistance on lengths greater than 300m.