

# SIEMENS

## Model 90 Motor Control Centers

### Instructions

Installation

Operation

Maintenance



Bulletin CC3318

# Table of Contents

## General Information Page

An Overview .....	3
Standards and Definitions .....	4
Siemens Advanced Motor Master System (SAMMS) .....	6

## Receiving and Handling

Receiving .....	8
Handling .....	8
Skid Removal .....	11
Storage .....	11

## Installation

Operating Environment .....	12
Site Preparation .....	12
Mounting .....	12
Top & Bottom Covers .....	13
Installation of Seismic Qualified Structures .....	15
Joining Shipping Sections .....	15
Ground Bus .....	17
Incoming Power Connections .....	17
Incoming Cable Spaces, Wiring	
Troughs and Wiring Terminations .....	18
Main Lugs at Top With Top Cable Entry .....	19
Main Lugs at Top With Bottom Cable Entry .....	19
Main Lugs at Bottom	
With Bottom Cable Entry .....	19
Main Lugs at Top	
With Top or Bottom Cable Entry .....	19
Main Disconnect With Bottom Cable Entry .....	20
Main Disconnect With Top Cable Entry .....	20
Load and Control Wiring .....	20
NEMA Type A Wiring .....	20
NEMA Type B Wiring .....	20
NEMA Type C Wiring .....	21
Field Additions .....	21
Drawout Unit Removal .....	22
Drawout Unit Addition .....	24

## Operation

Pre-Energization Checks .....	26
Energizing Equipment .....	28
Permissible Loading of Motor Control Centers .....	28

## Maintenance Page

General Inspection of MCC .....	29
Periodic Cleaning .....	30
Stab Fingers and Vertical Bus .....	30
Recommended Tightening Torques .....	31
Circuit Breaker Disconnect Operator .....	31
Adjustment Notes .....	32
Mechanical Interlock Adjustment .....	33
Maintenance After A Fault Has Occurred .....	34
Bus .....	34
Enclosure .....	34
Disconnecting Means .....	34
Terminals and Internal Conductors .....	35
Motor Starter .....	35
Adjustment of Sentron™ Type ETI Instantaneous Trip Motor Circuit Interrupter (1A-125A) .....	36
Adjustment of Circuit Breakers With Adjustable Instantaneous Trip (125A-1200A) .....	37
Field Testing of Circuit Breakers .....	37

## 3UA Overload Relay

3UA Overload Relay .....	38
Description .....	38
Single Phasing Protection .....	38
Manual or Automatic Reset .....	38
Overload Relay Selection and Adjustment .....	39
Procedure For Checking Nuisance Overload Tripping .....	39
Field Testing .....	41

## Troubleshooting

Troubleshooting Chart .....	42
Instruction Sheet References .....	46

## Figures

Figure 1. The Siemens Motor Control Center .....	3
Figure 2. Typical Structural Components .....	5
Figure 3. SAMMS Unit .....	6
Figure 4. The SAMMS Hand Held Unit .....	7
Figure 5. Motor Control Center, Sling, Roller, and Fork Lift Handling .....	9
Figure 6. MCC Anchor Bolt Location (without sill channels) .....	12
Figure 7. MCC Anchor Bolt Location (with sill channels) .....	13

# Table of Contents

	<b>Page</b>		<b>Page</b>
Figure 8. Welded Installation .....	14	Figure 24. Linear Motion Operator Mechanism ....	31
Figure 9. Grouting Method of Fastening Motor Control Center .....	14	Figure 25. Padlocking the Pan Brace Assembly ...	32
Figure 10A. Structural Joining of Shipping Sections .....	15	Figure 26. Padlocking the Handle in the "Off" Position .....	32
Figure 10B. Joining Shipping Sections, Horizontal Power Bus .....	16	Figure 27A. Mechanical Interlock- 3TB44 to 3TF44 .....	33
Figure 10C. Joining Shipping Sections, Ground Bus .....	17	Figure 27B. 3TB44 to 3TB44, All 3TF to 3TF .....	33
Figure 11. Main Lugs at Top with Top Cable Entry .....	19	Figure 28. The Stab Assembly .....	35
Figure 12. Main Lugs at Top with Bottom Cable Entry .....	19	Figure 29. Using the Fuse Removal Tool .....	36
Figure 13. Main Lugs at Bottom with Bottom Cable Entry .....	19	Figure 30. Operator Hinged Open to Expose Adjustment Dial on ETI Motor Circuit Interrupter .....	37
Figure 14. Main Lugs at Top with Top or Bottom Cable Entry .....	19	Figure 31. 3UA Overload Relay Time-Current Tripping Curves .....	38
Figure 15. Main Disconnect With Bottom Cable Entry .....	20	Figure 31. 3UA Overload Relay .....	38
Figure 16. Main Disconnect With Top Cable Entry .....	20	<b>Tables</b>	
Figure 17. NEMA Class I, Type A Wired Unit .....	21	Table I. MCC Frame Size and Weights .....	10
Figure 18. NEMA Class I, Type B Wired Unit .....	21	Table II. Incoming Service Cable Entry /Termination Space Requirements .....	18
Figure 19. NEMA Class I, Type C Motor Control Center .....	21	Table III. Recommended Tightening Torques .....	31
Figure 20. Ground Bus Splice of New Motor Control Center to ValueLine Mark 2 (Model A) .....	22	Table IV. Combinations of Mechanical Interlocks .....	33
Figure 21A. Operating Handle in the "Off" Position .....	22	Table V. Overload Relay Selection Table NEMA Sizes 1, 2, 3 and 4 .....	40
Figure 21B. Moving Terminal Blocks into the Wireway .....	23	Table VI. Overload Relay Selection Table NEMA Sizes 5 .....	40
Figure 22. Draw-Out Unit (Pan Assembly) Removal .....	25	Table VII. Overload Relay Selection Table NEMA Sizes 6 .....	40
Figure 23. Draw-Out Unit Addition, Steps A,B, C, and D .....	24	Table VIII. Overload Relay Selection Table NEMA Sizes 7 .....	40
		Table IX. Maximum Settings of Overload Relays .....	41
		Table X. Maximum Settings of Overload Relays When Values Indicated in Table IX Are Insufficient to Start .....	41

## NOTE

These instructions do not purport to cover all details or variations in equipment, nor provide for every possible contingency to be met in connection with installation, operation or maintenance. Should further information be desired or should particular problems arise which are not covered sufficiently for the purchaser's purposes, the matter should be referred to the local Siemens office.

The contents of this instruction manual shall not become part of or modify any prior or existing agreement, commitment or relationship. The sales contract contains the entire obligation of Siemens. The warranty contained in the contract between the parties is the sole warranty of Siemens. Any statements contained herein do not create new warranties or modify the existing warranty.

# General Information

## An Overview

### Introduction

The most effective means for grouping low voltage motor starters, associated control, and distribution equipment is through the use of "motor control centers". A concept introduced almost 50 years ago, MCC's provide a means of grouping motor starter units, feeder tap units, and auxiliary controls in a common sheet steel enclosure. Motor starters through NEMA Size 5 and all feeder disconnects through 225 amperes are normally supplied with drawout construction. Most devices within the MCC are powered from a common horizontal bus and individual three phase bus risers. Large starters and certain special units may have cable connections to the horizontal bus in lieu of a vertical bus. Once installed in its centralized operating plant location, supervision and monitoring can be performed safely and by a minimum number of personnel.

### Compact Components

Space-saving size of Siemens components results in spacious unit layouts for ease of installation, inspection and maintenance. Compactness also provides an advantage for adding auxiliary devices.

### Electrical and Mechanical Life

Contactors life expectancies are among the longest in the industry and low coil power consumption promises operating cost savings in all contactor sizes.

### NEMA Class 10 and Single Phase Protection

A unique overload relay designed to trip in 10 seconds or less under locked rotor conditions and less than 30 seconds under single phase conditions is offered as standard.

### I-T-E® Electrical Products Molded Case Circuit Breakers

State of the art "ETI" Circuit Breakers provide reliable protection with combination interrupting ratings up to 100,000 amperes—and without the use of fuses.

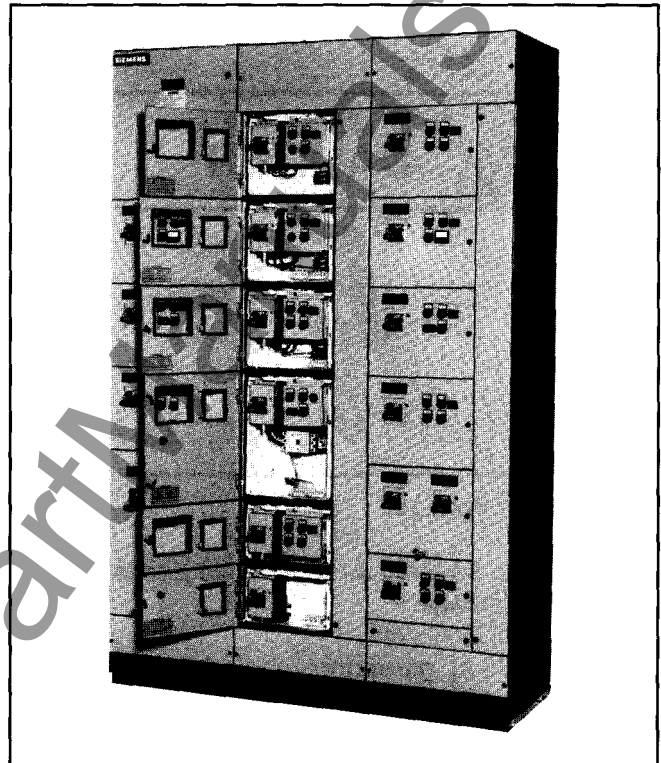

Figure 1: The Siemens Motor Control Center

### Spacious Wireway

A 40 square inch vertical wireway is one of the largest in the industry; provides room for a large number of control and power circuits. Horizontal wiring is accomplished through two oversize horizontal wireways. This design makes cable routing, inspection and clamp-on current measurements easier.

### Precision Stab Design

Assures proper alignment and extended life operation.

### Tubular Vertical Bus



Greater structural strength and increased heat dissipation for longer life.

### UL Listed Starters

Widest range of UL listing in the industry—from NEMA Size 1 through NEMA Size 7.

# General Information

## Standards and Definitions

 <b>DANGER</b>

<b>Hazardous Voltage.</b>
<b>Will cause severe personal injury, death, or property damage.</b>
<b>Only qualified personnel should work on or around this equipment after becoming thoroughly familiar with these publications and all information contained in this instruction manual.</b>
<b>Turn off power supplying this equipment before any adjustments, servicing, wiring, parts replacement, or before any act requiring physical contact with electrical working components of this equipment is performed.</b>

The successful and safe operation of motor control equipment is dependent upon proper handling, installation, operation and maintenance, as well as upon proper design and manufacture.

### QUALIFIED PERSON

For the purpose of this manual and product labels, a **QUALIFIED PERSON** is one who is familiar with the installation, construction and operation of equipment,

and the hazards involved. In addition, he has the following qualifications:

- (a) Is trained and authorized to energize, de-energize, clear, ground and tag circuits and equipment in accordance with established safety practices.
- (b) Is trained in the proper care and use of protective equipment such as rubber gloves, hardhat, safety glasses or face shields, flash clothing, etc., in accordance with established safety practices.
- (c) Is trained in rendering first aid.

Siemens Motor Control Centers are built in accordance with the latest applicable provisions of the National Electrical Code, Underwriters Laboratories Standards and Procedures, National Electrical Manufacturers Association, American National Standards Institute, and the National Electrical Safety Code.

### DANGER

For the purpose of this manual and product labels, **DANGER** indicates death, severe personal injury or substantial property damage will result if proper precautions are not taken.

### WARNING

For the purpose of this manual and product labels, **WARNING** indicates death, severe personal injury or substantial property damage can result if proper precautions are not taken.

### CAUTION

For the purpose of this manual and product labels, **CAUTION** indicates minor personal injury or property damage can result if proper precautions are not taken.

# General Information

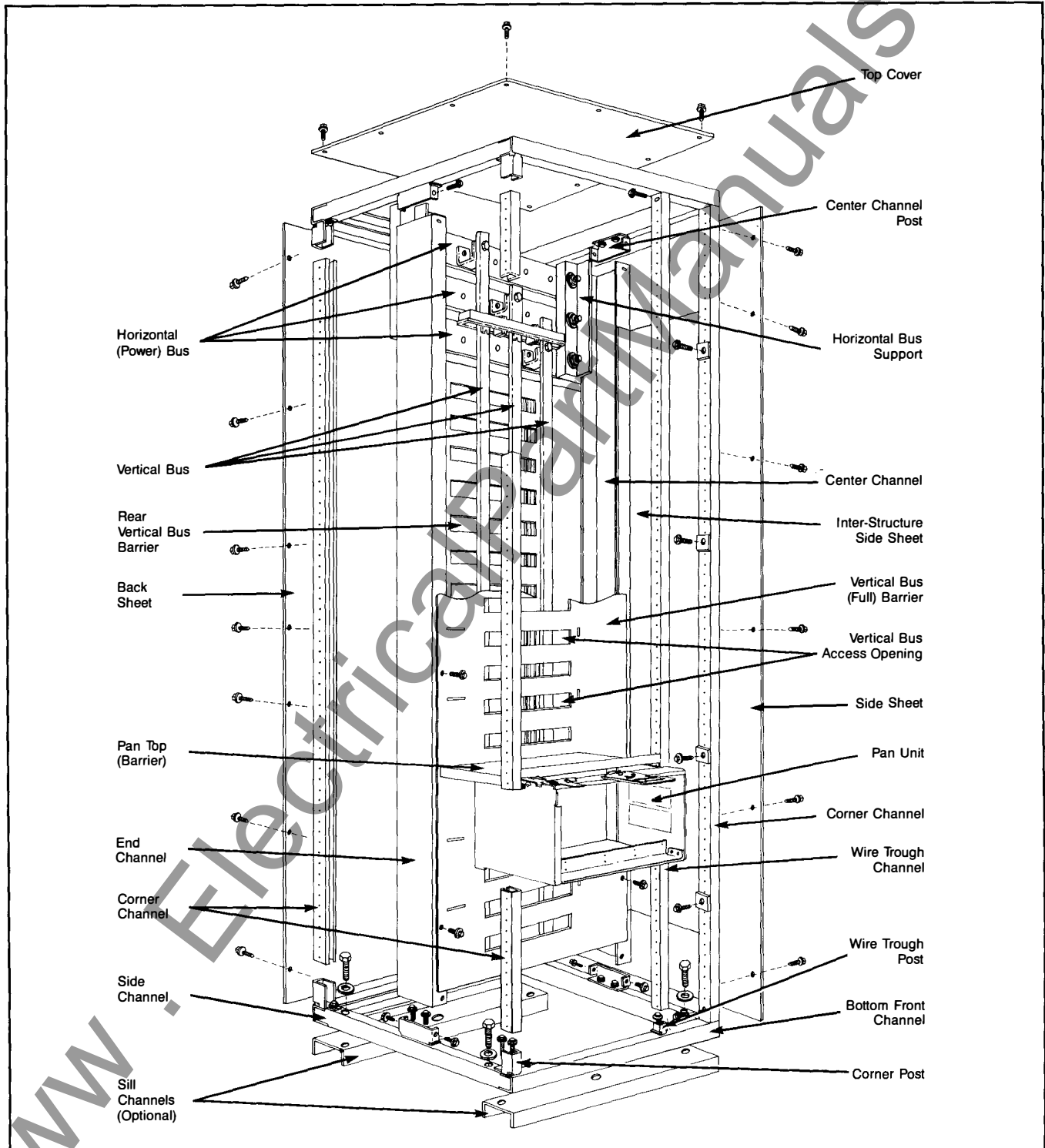

Figure 2. Typical Structural Components

### Siemens Advanced Motor Master System (SAMMS)

The Siemens Advanced Motor Master System (SAMMS) is a programmable electronic device which replaces conventional control relays and timers, push-buttons, pilot lights and overload relays. It consists of a controller which mounts in the MCC unit, plus a hand-held unit.

The SAMMS controller mounts in the MCC unit in the location normally occupied by the pilot device panel. A three-phase current transformer, located between the branch circuit protective device and the contactor, is used to monitor motor current. The control power transformer supplied with SAMMS-equipped starters contains an extra 12 volt secondary winding to supply power to the SAMMS.

The SAMMS was designed specifically for use in motor control centers and similar applications and can be applied in NEMA size 1 through size 6 starters. It can be programmed to control all common starter types, including across-the-line, reversing, reduced voltage autotransformer, reduced voltage reactor, two-speed, wye delta and part-winding. Programming of the SAMMS is normally done at the factory to the customer's specifications, but can be accomplished by the user using an optional available IBM PC-compatible software package.

The SAMMS front panel includes a keypad and indicating lights which provide the user with local control and visual status indication.

Overload protection provided by the SAMMS is based on an advanced motor model which continuously calculates the motor winding temperature as a function of the motor RMS current. The motor model compares the calculated temperature against maximum permissible temperature, and trips the motor off line if this value is exceeded. Selection of one of twenty-two overload trip classes allows customized motor stall protection.

By utilizing the SAMMS hand-held unit which includes a keypad, four digit numeric display and a cable which plugs into a receptacle on the front of the SAMMS, local display of motor and control circuit data and setting of certain operating parameters are possible. The number of features which can be accessed by the hand-held unit depends on the SAMMS model furnished.

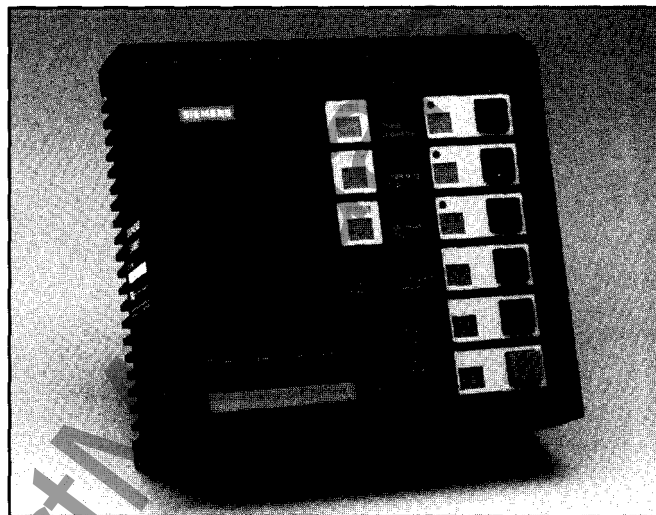

**Figure 3. SAMMS Unit To Equip Pan Unit**

SAMMS-1, designed for applications where trained maintenance personnel are not available, or where motor loads are of a non-critical nature, allows access to the following functions using the hand-held unit:

**Function F-1.** Displays the code number of the ladder diagram of the control circuit currently programmed into the SAMMS memory.

**Function F-2.** Displays the NEMA size of the starter.

**Function F-3.** Displays the NEMA size of the low speed contactor in the case of a two-speed starter.

**Function F-4.** Allows the user to input the full load amps of the motor, or the full load amps of the high speed winding in the case of a two speed motor.

**Function F-5.** Allows the user to input the full load amps of the low speed winding in the case of a two speed motor.

**Function F-6.** Allows the user to input the service factor of the motor.

**Function F-7.** Allows the user to select Class 10 or Class 20 overload protection.

**Function F-8.** Allows the user to enable or disable automatic reset after an overload trip.

**Function F-9.** Allows the user to enable or disable trip on phase current unbalance.

## General Information

**Function F-10.** Displays the time in seconds until reset is allowed after overload trip occurs.

**Function F-11.** Allows the user to override the inhibit start feature in the case of an emergency.

SAMMS-2, designed for applications where trained maintenance personnel are available to service the motors and driven equipment, provides functions F-1 through F-11, plus the following additional functions:

**Function F-12.** Ground fault on-off (optional on all three SAMMS models.

**Function F-13.** Displays the selected value of a built-in start delay timer. The "Run" light will flash until the timer reaches the on delay setting. When the contactor starts the motor the "Run" light will remain on.

**Function F-14.** Displays the selected value of a second built-in timer. The function of the second timer is defined by the control circuit programmed into the SAMMS. For example, it can provide time delay for switching between high and low speed for two speed controllers.

**Function F-15.** Displays the average phase current.

**Function F-16.** Displays the current in amps seen by the motor at the last trip.

**Function F-17.** Displays the unbalance current as a percent of the full load current.

**Function F-18.** Displays the total elapsed running time on the motor in tens of hours.

**Function F-19.** Displays total number of motor starts in tens of starts.

**Function F-20.** Displays the total number of overload trips which have occurred.

**Function F-21.** Resets functions F18, F19, and F20 to zero.

Also on SAMMS-2, Function F-11 provides selection between four overload trip classes: 5, 10, 15, and 20.

SAMMS-3 is designed for use in critical process environments where down time can result in great losses of production time and/or process material. It provides all

the functions of SAMMS-1 and SAMMS-2, plus the following:

**Function F-11.** Provides selection between twenty-two overload trip classes, from 2 through 23.

**Function F-16.** Displays each of the individual phase currents, as well as the highest phase current.

**Function F-22.** Allows the user to select a process current warning which will flash a warning if the motor current varies from a preset level. The current level at which the warning is given is adjustable from 0 to 100% of the motor full load amps.

**Function F-23.** Allows the user to enable or disable motor jam protection.

**Function F-24.** Allows the user to choose either loss of load warning or protection. Depending on the setting, the SAMMS will either flash a warning or trip the motor off line if a sudden loss of load occurs.

**Function F-25.** Displays the ratio of the calculated motor winding insulation temperature to the normal motor winding insulation temperature at full load current.

For additional information on operation and maintenance of the SAMMS, refer to SAMMS instruction manual.



Figure 4. The SAMMS Hand Held Unit

# Receiving and Handling

## Receiving

Upon receipt of the Siemens Motor Control Center, an immediate inspection should be made for any damage which may have occurred during shipment. The inspection should begin with the packaging material and proceed to the equipment within. Be sure to look for concealed damage and do not discard the packaging material. If damage is found, note damage on "Bill of Lading" prior to accepting receipt of the shipment, if possible.

### NOTE

The way visible shipping damage is treated by the consignee prior to signing the delivery receipt can determine the outcome of the damage claim to be filed. Notification to the carrier within the 15 day limit on concealed damage is essential if loss resulting from unsettled claims is to be eliminated or minimized.

A claim should be immediately filed with the carrier, and the Siemens sales office should be notified if damage or loss is discovered. A description of the damage and as much identification information as possible should accompany the claim.

## Handling

The Siemens Motor Control Centers are shipped in groups of from one to four vertical frames which are mounted on 4" x 4" wooden shipping blocks. When single frames are shipped individually, each is additionally mounted on a special pallet for further stability. Lifting brackets are supplied for each shipping section. If the brackets are shipped loose, assemble the brackets to the top structural members of the control center as shown in Figure 5. One bolt attaches the bracket to a 16 inch deep frame. The 20 inch deep frames require two bolts per bracket. Tighten 3/8" hardware to 20 - 30 ft. lbs.

**WARNING**



**Heavy Equipment.**

**Can result in death, severe personal injury, or substantial property damage.**

**Exercise extreme care when handling the motor control center. A crane or hoist should be used if at all possible.**

**Exercise all safety precautions outlined in the following discussion.**

The following precautions must be taken whenever moving an MCC:

1. Handle the motor control center with care to avoid damage to components and to the frame or its finish.
2. Handle the motor control center in an upright position only. Motor control centers are normally front heavy and frequently top heavy. Balance the load carefully and steady the motor control center, as necessary, while moving. Some motor control center interiors may contain heavy equipment, such as transformers mounted within, that could be adversely affected by tilting.
3. Know the capabilities of the moving means available to handle the weight of the motor control center. Adequate handling facilities should be available. The following table gives the approximate

# Receiving and Handling

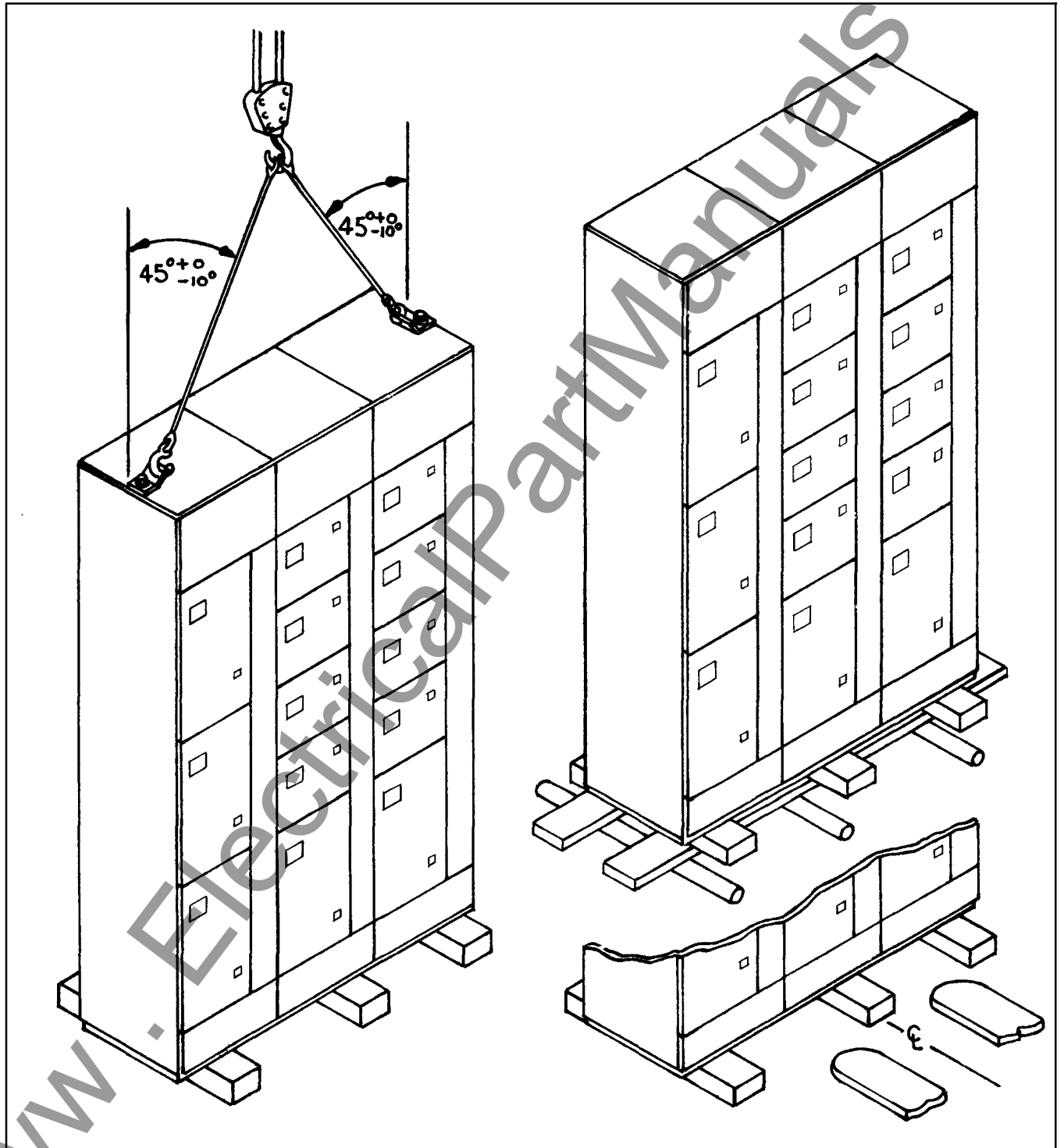

Figure 5. Motor Control Center, Sling, Roller, and Fork Lift Handling

# Receiving and Handling

weights of single vertical frames and will be helpful in determining the required capacity of the handling means. If a vertical frame contains power factor correction capacitors, reactors, or a large transformer, sufficient additional weight handling capacity must be allowed.

**Table I.**

FRAME	WEIGHT
20 " W x 16 " D Front Only	550 lb.
20 " W x 20 " D Front Only	600 lb.
20 " W x 20 " D Back-to-Back	850 lb.
30 " W x 20 " D Front Only	850 lb.

4. It is recommended that a crane or hoist be used to handle the MCC if at all possible. If a crane or hoist is not available and other handling means are necessary, extreme care must be exercised to insure that the equipment is secured during the movement and placement operations to prevent tipping and falling. Jacks, prybars, dollies, roller lifts, and similar devices all require supplemental blocking beneath the MCC and restraints to prevent tipping. These devices are not recommended due to the hazards implicit in their use.

The following precautions should be taken when moving an MCC with a crane or hoist:

1. Select rigging lengths to compensate for any unequal weight distribution and to maintain the motor control center in an upright position.
2. Do not allow the angle between the lifting cables and vertical to exceed 45° as shown in Figure 4.
3. Do not pass ropes or cables through lifting brackets. Use only slings with safety hooks or shackles.
4. Never lift an MCC above an area where personnel are located.

The following precautions should be taken when moving an MCC with a forklift:

1. Make sure the load is properly balanced on the forks.
2. Place protective material between the MCC and forklift to prevent bending and scratching.
3. Securely strap the MCC to the forklift to prevent shifting or tipping.
4. Excessive speeds and sudden starts, stops, and turns must be avoided when handling the MCC.
5. Lift the MCC only high enough to clear obstructions on the floor.
6. Take care to avoid collisions with structures, other equipment, or personnel when moving the MCC.
7. Never lift an MCC above an area where personnel are located.

The following precautions should be taken when moving an MCC by rolling on pipes:

1. Use enough people and restraining devices to prevent tipping.
2. The surface over which the MCC is rolled must be level, clean and free of obstructions. **NEVER ROLL AN MCC ON AN INCLINED SURFACE.**
3. It should be recognized that rolling an MCC is especially hazardous to fingers, hands, and feet and is susceptible to tipping. Measures should be taken to eliminate these hazards.
4. All pipes must be the same outside diameter and should have no flat spots. Only steel pipe should be used for this purpose.

# Receiving and Handling

---

## Skid Removal

Skid removal should be performed just prior to final placement of the control center and is achieved by first removing the bottom horizontal wire space covers which allows access to the skid lag bolts. Install the lifting brackets (see Figure 5) to the top of the MCC (torque bolts to 20-30 ft. lbs.) and attach the crane rigging to these brackets. Apply sufficient tension on the rigging to remove all slack without lifting the equipment. This is a recommended safety measure to reduce the possibility of tipping. The lag bolts may now be removed, the MCC lifted, the skids removed, the MCC lowered into place, and the anchor bolts secured. The last operation should be performed with adequate rigging tension to prevent tipping. After all additional shipping sections are secured in a similar manner, sections and bus bars should be joined in accordance with the instructions in the Installation section of this manual. Close doors and reinstall covers as soon as possible to eliminate intrusion of dirt and foreign materials into the MCC enclosure.

## Storage

An indoor motor control center or separate unit, which is not installed and energized immediately, should be stored in a clean dry space where a uniform temperature prevents condensation. Preferably, it should be stored in a heated building, with adequate air circulation and protected from dirt and water. Motor control centers and units should be stored where they are not subject to mechanical damage.

If the motor control center is to be stored for any length of time, prior to installation, restore the packing for protection during that period. Where conditions permit, leave the packing intact until the motor control center or sections are at their final installation position. If the packing is removed, cover the top and openings of the equipment during the construction period to protect them against dust and debris.

An indoor motor control center that must be stored outdoors should be securely covered for protection from

weather conditions and dirt. Temporary electrical heating should be installed to prevent condensation; approximately 150 watts per section is adequate for the average motor control center's size and environment. All loose packing or flammable materials should be removed before energizing space heaters.

An unenergized outdoor motor control center should be kept dry internally by installing temporary heating (see above), or by energizing optional self-contained space heaters.

Any scratches or gouges suffered from shipping or handling should be touched up with a can of spray paint to prevent rusting.

# Installation

## Operating Environment

The Siemens Motor Control Center conforms with the provisions of NEMA Standard ICS1 - 108, Altitude Class 2KM which defines the usual service condition for electromagnetic control. It is designed for indoor use where the temperature inside the control center is higher than the ambient temperature. The control center is capable of carrying its rated load when the ambient temperature does not exceed 40° C and the altitude does not exceed 6600 feet above sea level. Where unusual service conditions exist or where temperature or altitude limitations are exceeded, the control center construction, ratings, or protection may require alteration. Some examples of unusual service conditions are excessive moisture, vibration, or dust, especially of an electrically conductive or thermally insulating nature or areas prone

exposed to ambient temperatures above 40° C (104° F), corrosive or explosive fumes, dust, vapors, dripping or standing water, abnormal vibration, shock or tilting, or other unusual operating conditions.

The Siemens motor control center should be installed in a clean dry heated place with good ventilation and it should be readily accessible for scheduled maintenance. A flat, level concrete surface should be prepared for the mounting site. If the mounting site is not flat and level, the motor control center must be shimmed where necessary to prevent distortion of the structure.

All conduit entering from the bottom should be in place and stubbed up about two inches above the finished floor level before installing the control center. Refer to the MCC lead sheet plan view located in the information packet for specific conduit area dimensions.

## Site Preparation

Installation shall be in accordance with the National Electrical Code, ANSI and NFPA 70 Standards. Unless the motor control center has been designed for unusual service conditions, it should not be located where it will be

## Mounting

Motor control centers may be mounted by many different fastening systems including true drop in, cast in place, powder actuated, or threaded insert fasteners. See

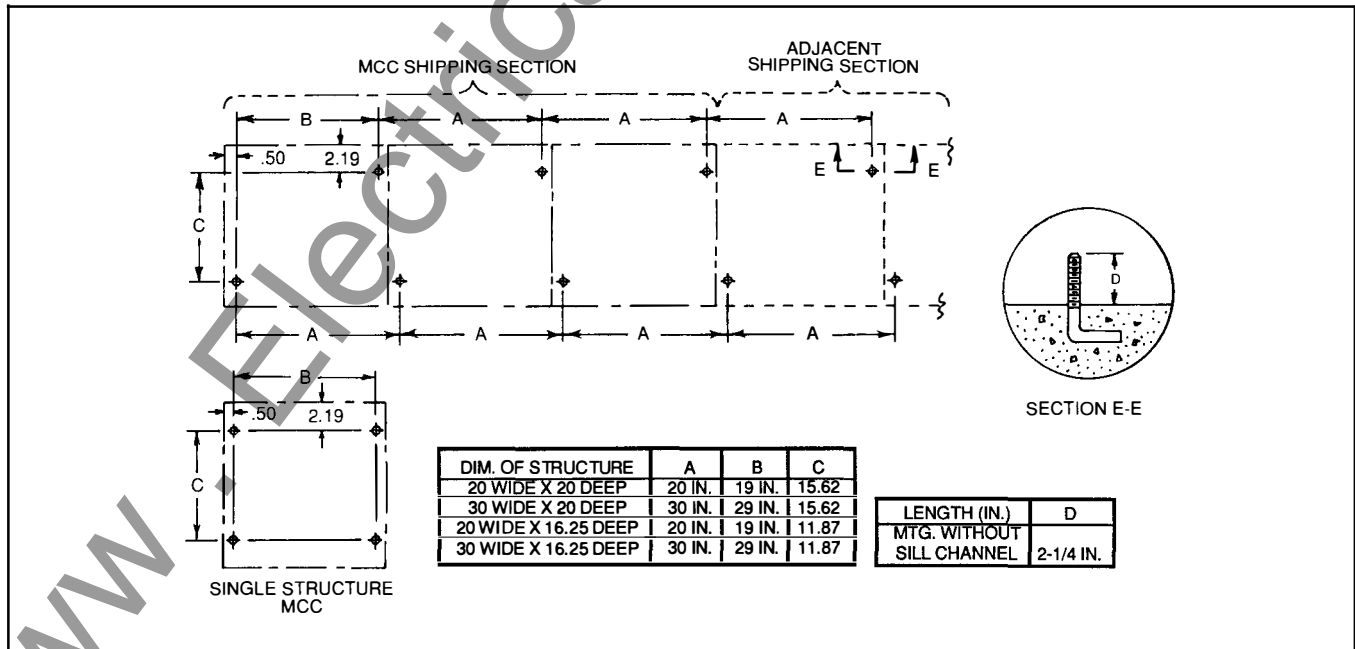

Figure 6. MCC Anchor Bolt Location (without sill channels)

# Installation

Figures 6 and 7 for anchor bolt locations. The bolt pattern is dependent on frame width, depth, location in the line-up and whether or not sill channels are furnished. A floor plan drawing located in the print pocket details the anchor bolt locations. The coordination between bolts and the MCC should be verified prior to attempting installation. Expandable inserts in predrilled holes or imbedded "L" bolts are recommended. Wooden plugs driven into holes in masonry or concrete are not recommended for anchoring inserts and should never be used. The bolt size must be 3/8".

Welding the steel base or sill channels to a steel floor plate is an alternate mounting method especially recommended in areas subject to seismic activity. See Figure 8 for details.

Grouting the sill channels as indicated in Figure 9 is another method of fastening. This method requires the foundation to be grooved as shown to accept the sill channels. The sill end covers must be removed prior to

placing the MCC into the grooves. The actual groove dimensions must be coordinated with the floor plan layout on the lead sheet included in the motor control center information packet.

If the control center is located on structural steel platforms over grids, it is recommended that the center be modified with bottom plates. Channel sill end covers are supplied with those control centers which employ sill channels to cover the openings at the ends of the center if the channels are above grade.

## Top & Bottom Covers

Top covers are provided on all motor control centers as an integral part of the enclosure. Bottom covers are supplied on certain types of construction such as NEMA 12. These covers should be removed only for the purpose of piercing holes for conduit or wire entry and must be immediately replaced to reduce the possibility that falling material, tools, or personnel could unintentionally contact the bus system or other live parts.

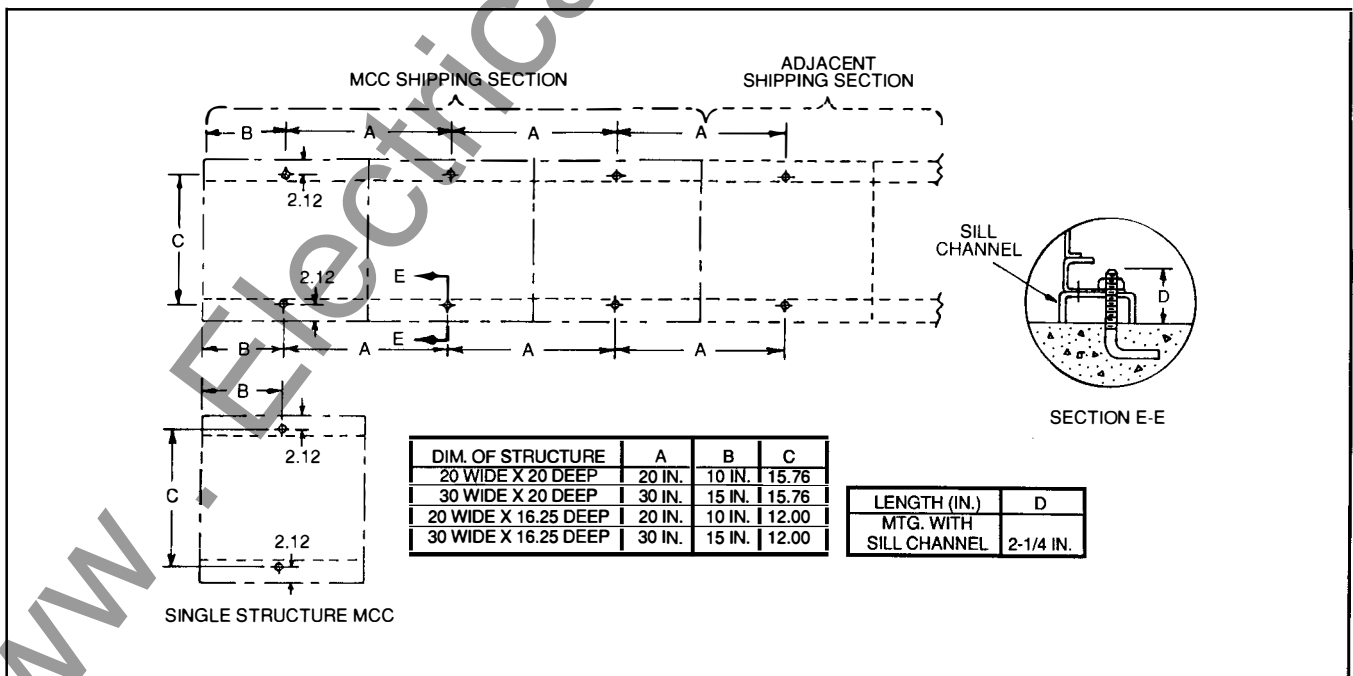

Figure 7. MCC Anchor Bolt Location (with sill channels)

# Installation

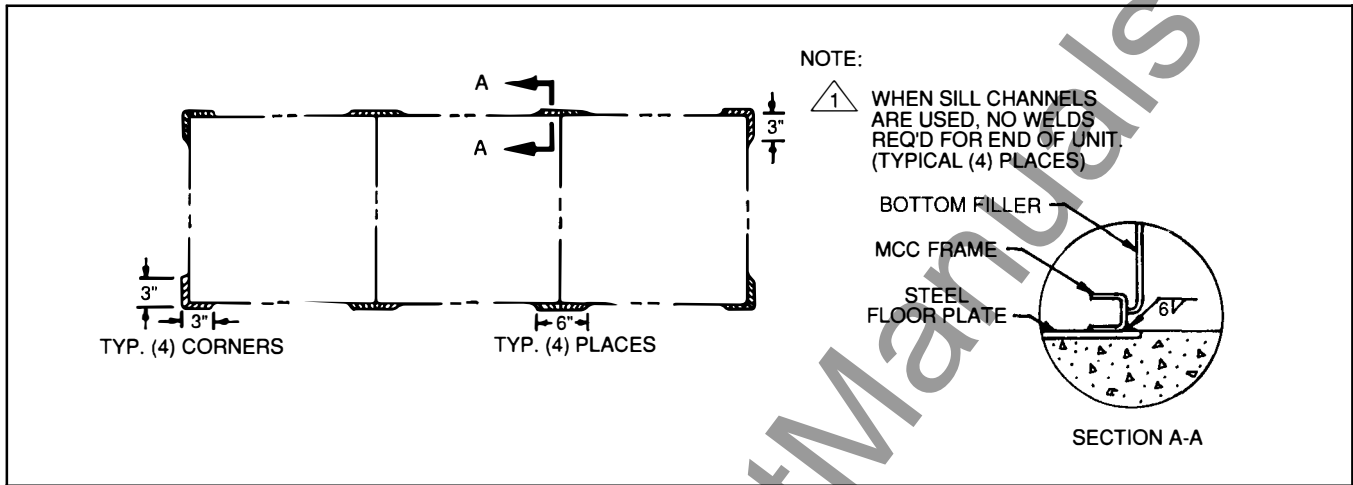

Figure 8. Welded Installation

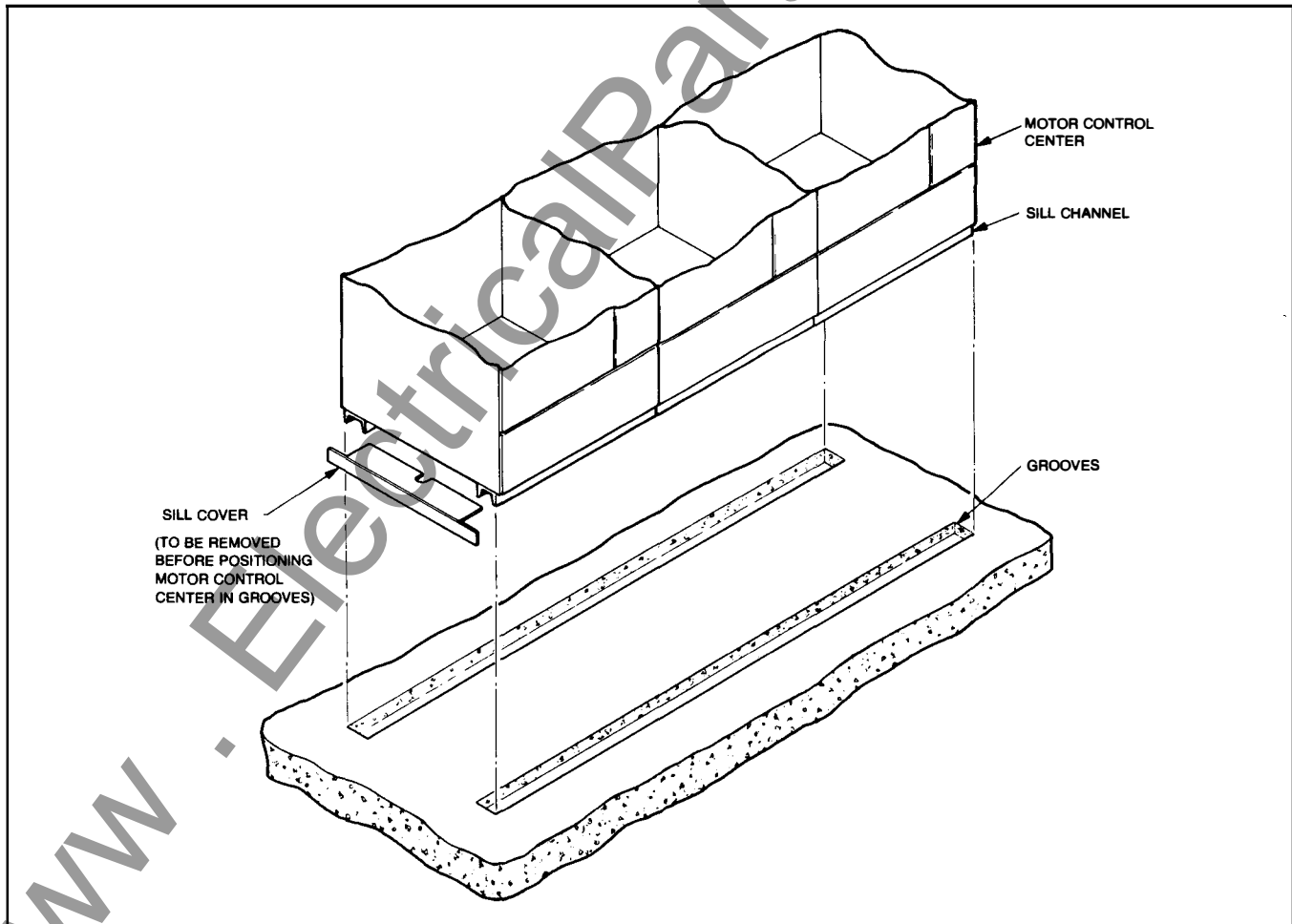

Figure 9. Grouting Method of Fastening Motor Control Center

# Installation

## Installation of Seismic Qualified Structures

Special installation arrangements are required for seismic qualified structures. Specific mounting procedures specified on the contract drawings or motor control center lead sheet must be explicitly followed to maintain the seismic withstand rating. Removal or rearrangement of frames may void the control center seismic qualification.

## Joining Shipping Sections

Shipping sections consist of up to four vertical frames shipped as a single unit. It is often necessary to join two or more shipping sections at the job site. All necessary electrical and structural joining components are provided and the following procedures are recommended.

1. Position the first shipping section into place on the foundation and level.
2. Remove the front horizontal bus barrier and the side sheet from the end(s) to be joined. If the rear is accessible, the back cover plates should be removed from the two mating frames.
3. Position the second shipping section on the foundation adjacent to the first and level it. The horizontal bus should be inspected for proper positioning and alignment at this time.
4. Connect the shipping sections together by positioning the structure joining clips over the adjacent corner posts above and below the interframe barrier as shown in Figure 10A. Secure each clip with four self tapping screws, two on each side.
5. Assemble the bus bar links to join the horizontal power bus and neutral bus, if supplied, in the two shipping sections as shown in Figure 10B. The horizontal and neutral buses may differ in size, material, or plating, therefore, the links must be matched to the proper bars. All links and associated mounting hardware are provided with the motor control center.

6. Torque all bus connections to 40-50 ft. lbs.
7. If the motor control center has interwiring, connect the inter-unit wiring terminal blocks between shipping sections.
8. Join the ground bus between the two adjacent sections, if supplied. The Ground Bus Section in this manual details this procedure.
9. If there are other shipping sections to be joined, repeat steps 1 through 8 above.
10. Secure the motor control center to the foundation.
11. NEMA 3 enclosure sections should be securely joined and sealed to prohibit intrusion of dust and moisture.

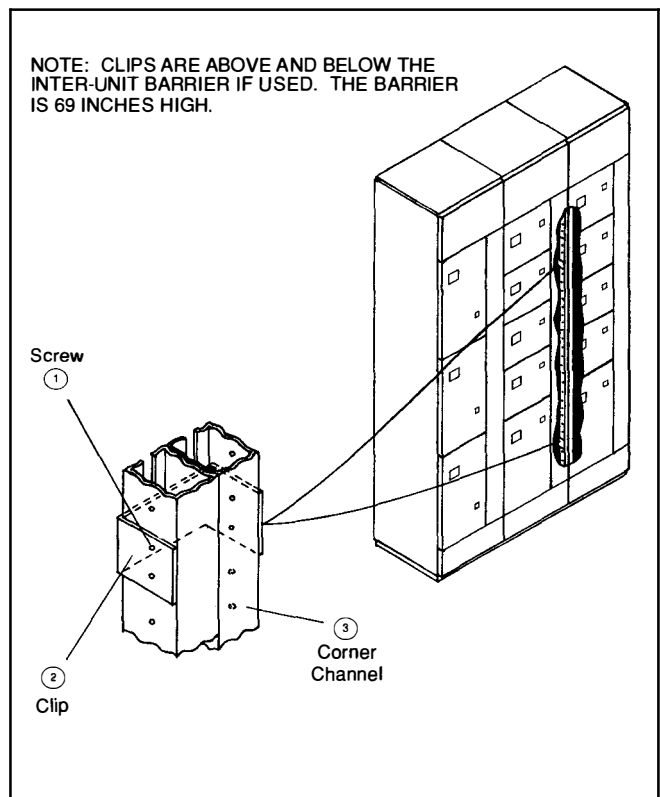

**Figure 10A. Structural Joining of Shipping Sections.**

# Installation

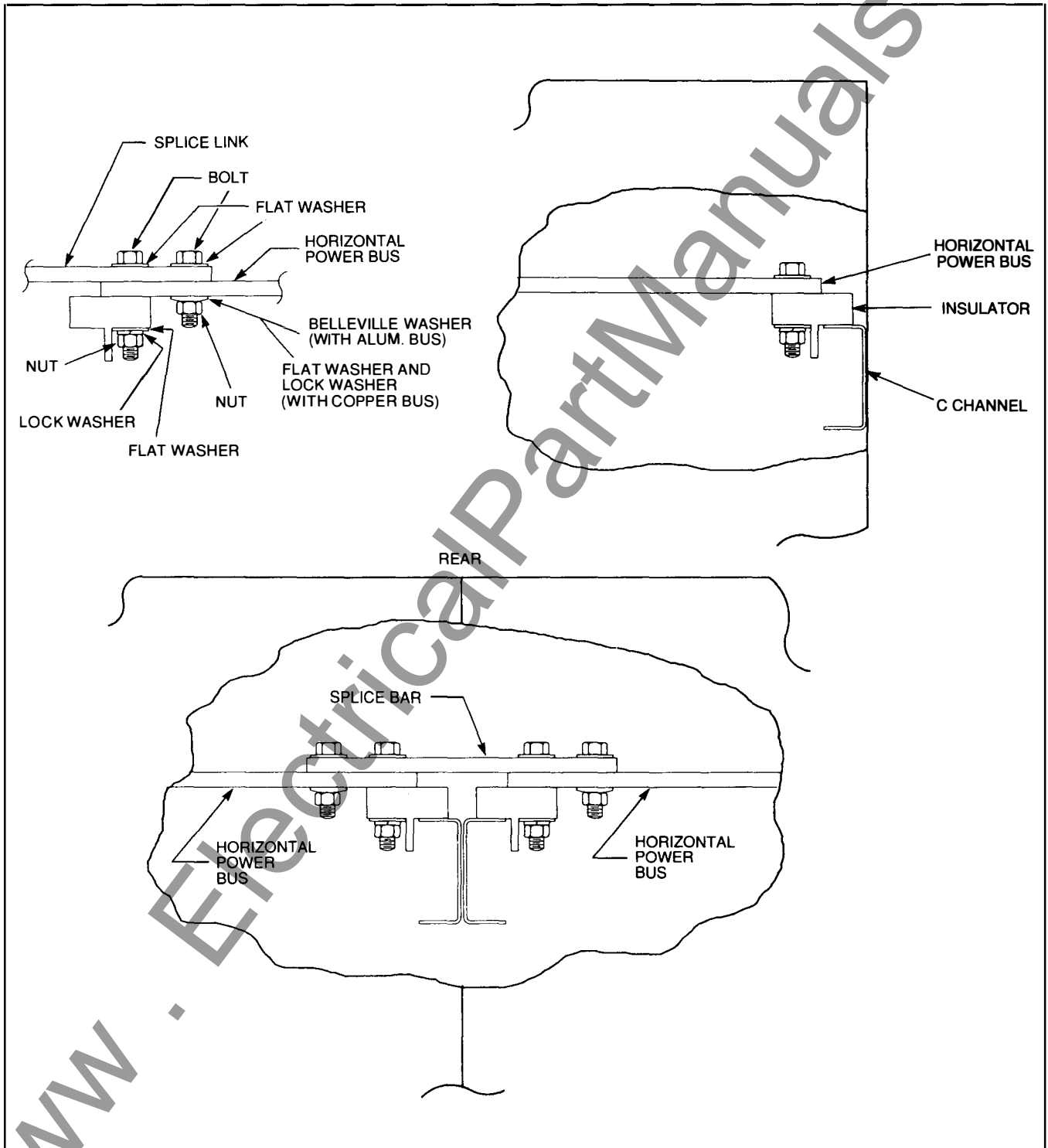
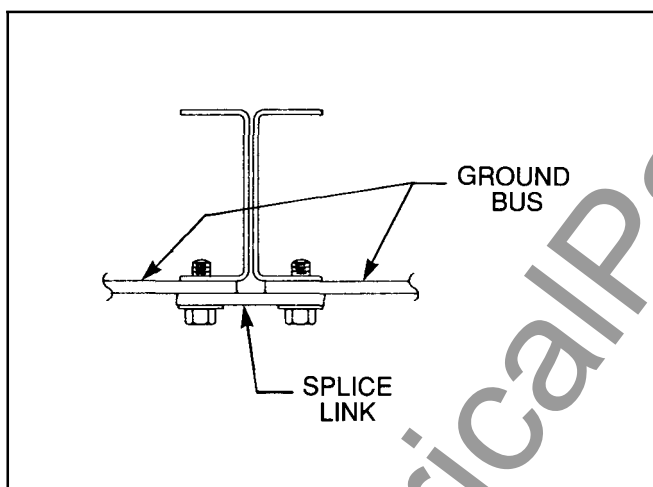

Figure 10B. Joining Shipping Sections, Horizontal Power Bus

# Installation

## Ground Bus

All hardware and links are supplied for joining the ground bus between two shipping sections. This joining may be accomplished by loosening the screw securing the connection link so that the link pivots freely. Remove the screw securing the ground bus in the adjacent frame to which the link will attach. Pivot the free end of the link such that the hole is aligned with the bolt, then reassemble the screw and link assembly. Tighten hardware. See Figure 10C.



**Figure 10C. Joining Shipping Sections, Ground Bus.**

## Incoming Power Connections

### NOTE

Remove top covers before cutting holes for conduit to prevent metal chips from falling into the motor control center.

Conduits should be carefully installed to prevent moisture or water from entering and accumulating within the enclosure. All conduits (including stubs) should be bonded to the motor control center. After all shipping sections are in place, leveled and joined together into a single motor control center, cables may be pulled and top entry conduit may be installed. Bottom entry conduit will have been stubbed through the floor at the proper locations prior to placement of the motor control center. The incoming source cables may be connected at this time, however, the power source disconnecting means must remain open and locked out until all wiring is completed and the entire system has been checked out. Care must be exercised to make sure that the lugs which have been provided are suitable for use with the type of cables being installed in the motor control center. If crimp lugs are supplied, use only the crimping tool recommended by the lug manufacturer. Care should be exercised in stripping insulation from the conductors to prevent nicking the conductor. For aluminum, clean all oxide from the stripped portion and apply inhibiting compound at once. Tighten all screw lugs and bolted electrical connections to the specified torque listed in the table in the maintenance section of this instruction manual.

To minimize the length of unsupported cable, the shortest, most direct routing should be chosen. However, the largest practical bending radii should be maintained to avoid damaging the insulation and to avoid causing terminals to loosen. All cables entering the motor control center must be adequately supported and restrained to withstand the maximum fault current capable of being delivered by the source. The recommended distances between straps for 80 pound rated strap is 6 inches for 25 KA bracing, 4 inches for 42 KA bracing and 3 inches for 65 KA bracing. Using a strap rated less than 80 pounds will require the spacing distances to be reduced. For 100 KA bracing, cables must be supported in accordance with the special instructions provided with the motor control center. Typical incoming line arrangements are shown in Figures 11 through 16.

# Installation

## Incoming Cable Spaces, Wiring Troughs and Wiring Terminations

The National Electrical Code establishes very specific guidelines for minimum cable bending space within motor control centers. In particular, Article 373-6 of the NEC details these requirements. Figures 11 through 16 describe the most common arrangements for terminating main incoming power cables to the motor control center. Consult the factory for incoming line compartment braced for 100,000 amperes, short circuit. The following table summarizes these and other standard termination schemes.

**Table II.**

Fig. No.	Description of Incoming Service	Top or Bottom Inc. Section	Cable Entry	Space Req'mts	Comments
14	≤ 350 MCM One Per Phase	Top--Directly on Main Bus	Either	None	See Figure 14
11, 12	≤600 MCM One or Two Per Phase	Top	Either	Top Wire way Plus 12" or 18"	See Figures 11 and 12
–	≤600 MCM Three or Four Per Phase	Top	Either	Top Wireway Plus 12" or 18" X 2	Parallel Incoming Lines At Top of Adjacent Vertical Sections
–	750 MCM One or Two Per Phase	Top	Either	Top Wireway Plus 36"	
13	≤800 MCM One or Two Per Phase	Bottom	Bottom	Bottom Wireway Plus 12" or 24"	600 A. Max. See Figure 13
–	>750 MCM	Top or Bottom	Either	Consult Factory	Consult Factory
15	≤500 MCM One or Two, Per Phase ≤750 MCM One per phase To a Main Breaker	Top	Bottom	See Breaker/ Disconnect	See Figure 15
16	≤500 MCM One to Four Per Phase ≤750 MCM One per phase To a Main Breaker	Top	Top	See Breaker/ Disconnect	See Figure 16
–	Cable Feed To Incoming Line Reactor	Full Height	Either	Full Structure	30" Wide Structure
–	Busway	Top or Bottom	Either	Consult Factory	Consult Factory

Siemens Motor control Centers are equipped with a 9" high, full-width horizontal wireway in both the top and bottom of each structure. A separate vertical wireway connects the top and bottom wiring areas in each vertical section. This wireway is 5" wide by 8" deep (40 square inches).

## Main Lugs at Top With Top Cable Entry

Can accommodate up to two 600 MCM cables per phase. Requires a total height of 21" (9" top wireway, plus 12" of unit mounting space).

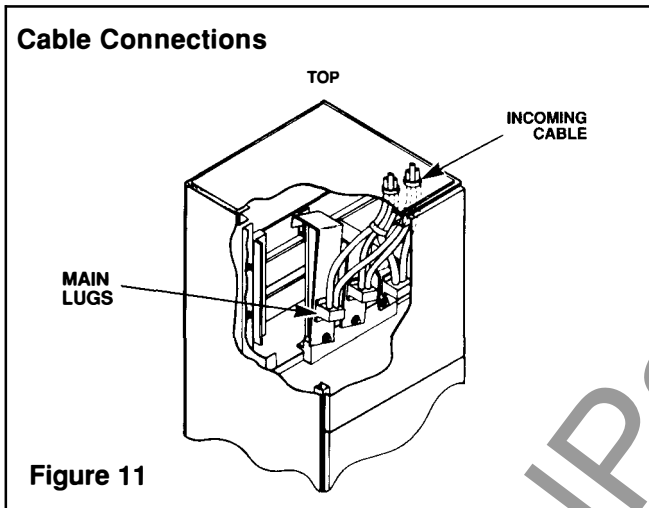

Figure 11

## Main Lugs at Top With Bottom Cable Entry

Can accommodate up to two 250 MCM or one 500 MCM cable per phase in the standard 21" height (9" top wireway, plus 12" of unit mounting space). Can accommodate up to two 600 MCM cables per phase in a 27" high compartment (9" + 18").

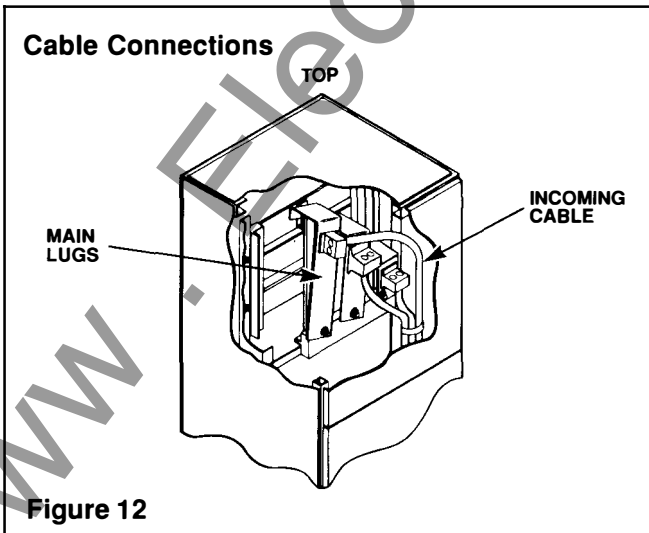

Figure 12

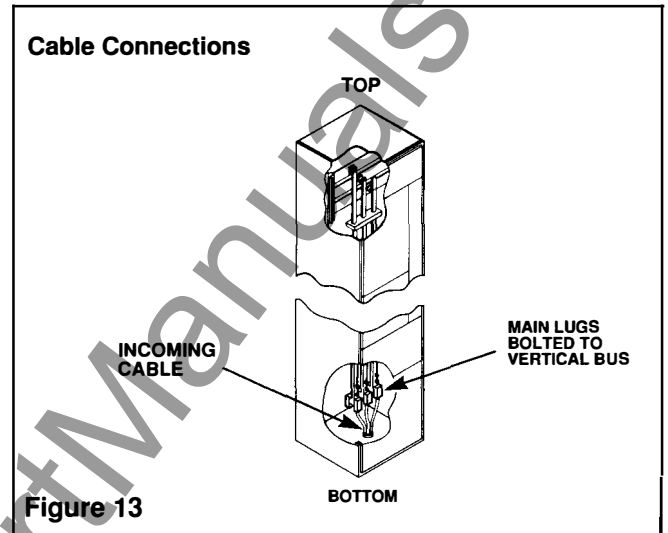

Figure 13

## Main Lugs at Bottom With Bottom Cable Entry

Lugs are bolted directly to the bottom of the vertical bus. Can accommodate up to two 350 MCM per phase in 21" high compartment (9" high bottom wireway plus 12" of unit mounting space). Can accommodate up to two 800 MCM per phase in 33" high compartment (9" + 24").

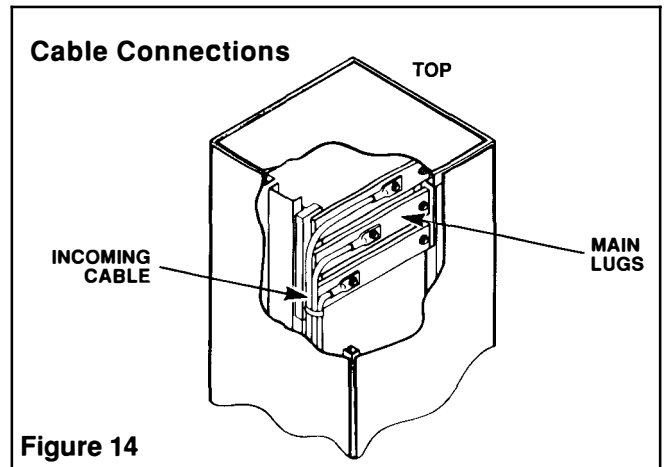

Figure 14

## Main Lugs at Top With Top or Bottom Cable Entry

In this arrangement the lugs mount directly on the horizontal bus, thus eliminating the need to use unit mounting space. The limitation here is one 350 MCM cable per phase and rear or side accessibility.

## Main Disconnect With Bottom Cable Entry

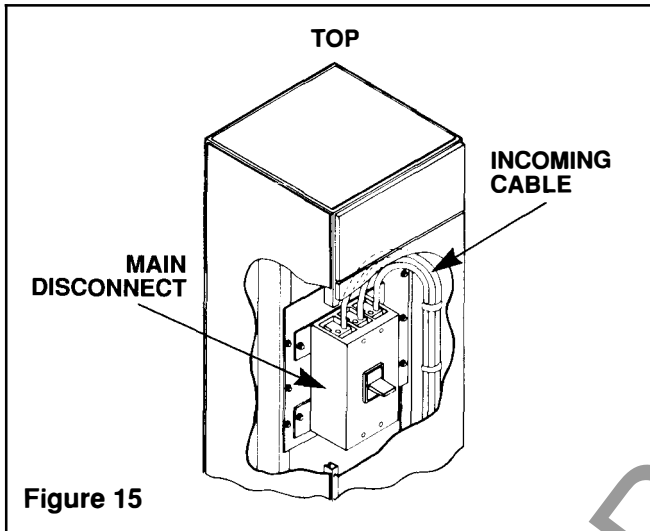

Figure 15

## Main Disconnect With Top Cable Entry

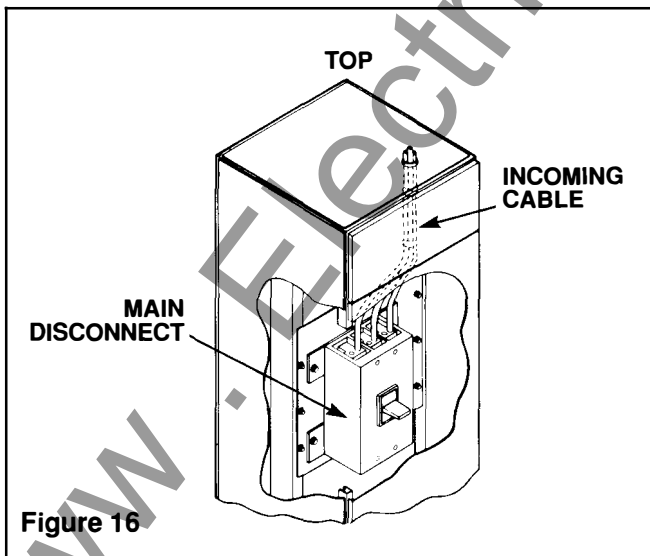

Figure 16

## Load and Control Wiring

All interconnections between devices within each control unit are prewired at the factory. Field wiring to each control unit should be made in accordance with the wiring diagram indicated on the lead sheet for that particular unit. The lead sheet and wiring diagrams are included in the information packet. When wiring or performing any maintenance on drawout units, disengage the stabs by withdrawing the unit. Refer to pages 22 and 23, "Drawout Unit Removal," Steps 1 through 5. Wiring done with the pan in this position will ensure adequate cable slack to allow unit withdrawal to the same position when future maintenance is required. Always use stranded wire.

The vertical wiring between control units or between a control unit and conduit should be pulled through the wiring space on the right side of the frame. These wires should then be tied or laced together and the resulting bundle then securely fastened to the wire supports. Connections between a front mounted control unit and a rear mounted control unit in a back-to-back control center should be made at the bottom of the frame. Interconnecting wiring between control units mounted on the same side of the MCC should be routed through the top horizontal wire space.

Installation and wiring must be in accordance with NFPA-70, ANSI, the National Electrical Code and any other applicable regional codes or regulations.

## NEMA Type A Wiring

Motor control centers with NEMA Type A wiring do not include terminal blocks. See Figure 17. All field wiring, both power and control, should be connected directly to the individual components.

## NEMA Type B Wiring

Motor control center units with NEMA Type B wiring are equipped with control terminal blocks to which the factory wiring is connected. Figure 18 depicts this wiring which adds a rail mounted terminal block for outgoing connections.

# Installation

## NEMA Type C Wiring

Figure 19 shows a motor control center equipped with NEMA Type C wiring which includes all the features described for NEMA Type B wiring in addition to master terminal blocks located at either the top or bottom of the vertical frames.

The motor control center lead sheet indicates the type of wiring provided for this installation.

### NOTE

Six 12 inch drawout assembly module spaces per frame are available in the front, five in the rear, with the rear side tracks set an inch higher than the front to prevent stab assembly interference on the vertical bus. Drawout assemblies may be mounted on either the front or rear, but there will be a phase reversal when mounted on the rear. This should be taken into consideration when terminating motor cables.

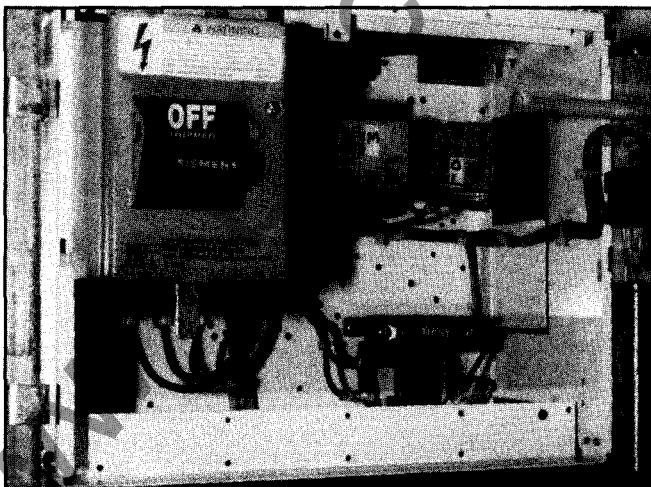

Figure 17. NEMA Class 1, Type A Wired Unit

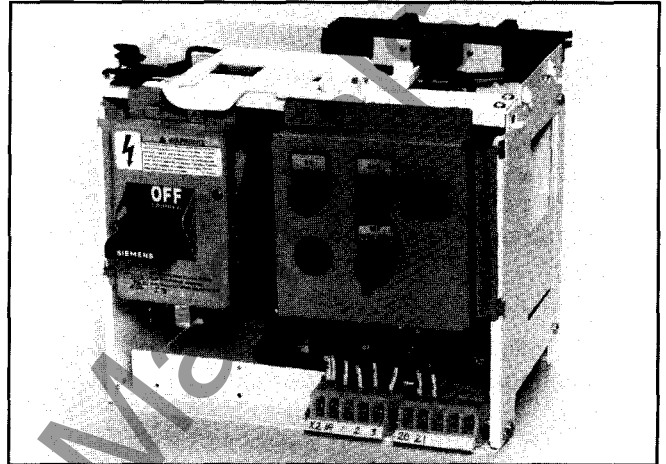

Figure 18. NEMA Class 1, Type B Wired Unit.

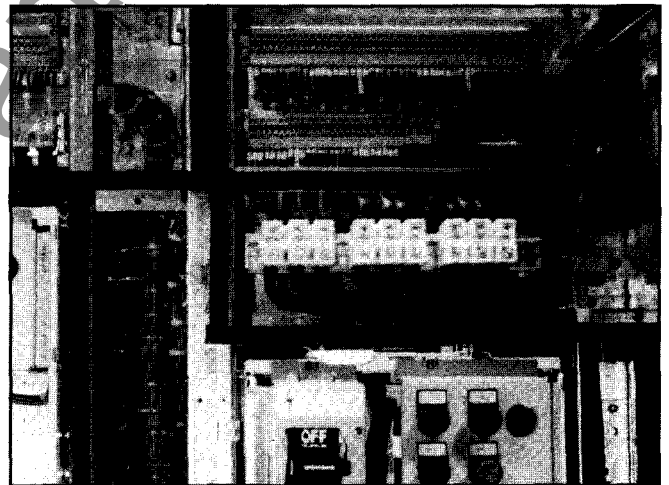

Figure 19. NEMA Class 1, Type C Motor Control Center.

## Field Additions

Field additions may be made to the control center if the current rating of the main or vertical bus is not exceeded. The preparation of the floor and conduit is the same as in a new installation. Any new shipping section will contain all of the necessary hardware and bus connecting links. De-energize the existing motor control center and remove the end side plates from the new and existing vertical frames which are to be joined. After joining the structures per the instructions in the installation section of this manual, perform the pre-energization checks outlined in the operation section of this instruction manual.

# Installation

Additions to motor control centers fall into two general categories: additions of frames and additions or replacement of drawout units. The addition of frames is similar to the installation of control centers which have been shipped in several sections. When mounting methods or models of new and existing sections differ, care must be exercised to ensure proper alignment of horizontal bus. The new frames are then treated the same as in a new installation. This is discussed in detail in the Joining Shipping Sections portion of this manual.

A special splice bar is provided for the ground bus when connecting to a ValueLine motor control center. See Figure 20 for details.

## Drawout Unit Removal

The following sequences should be followed when removing a drawout unit:

1. Turn unit off using STOP button or selector switch. (If supplied).

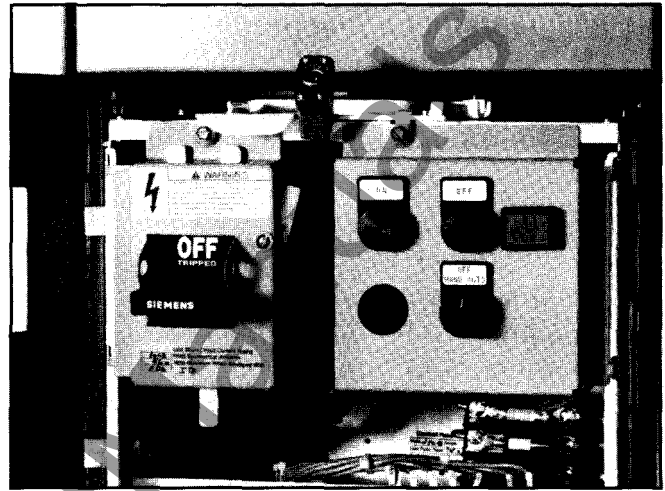

Figure 21A. Operating Handle in the "Off" Position

2. Push the disconnect operating handle down (Figure 21A) to the OFF position.
3. Turn the quarter turn door fasteners 90° with a screwdriver and open the door.

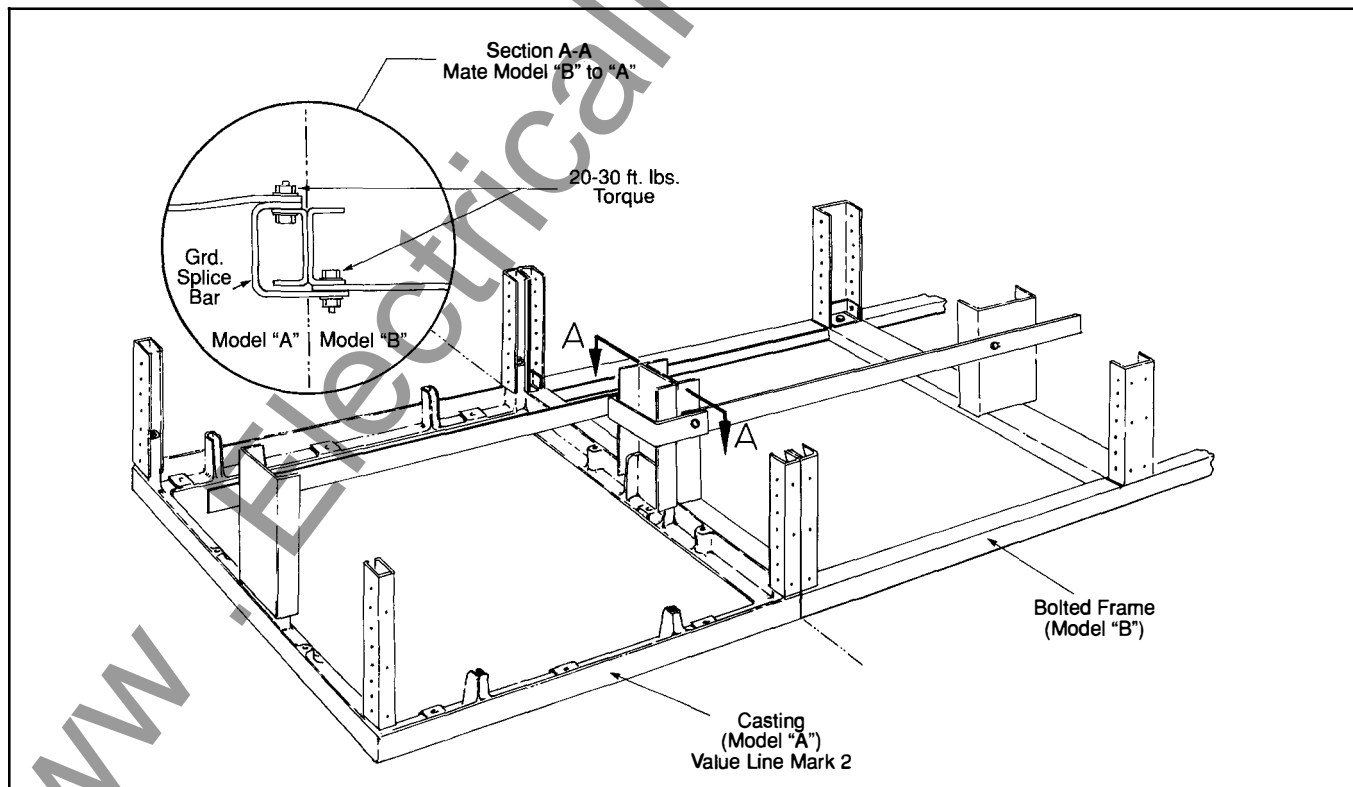



Figure 20. Ground Bus Splicing of New Motor Control Center to ValueLine Mark 2 (Model A).



Figure 21B. Moving Terminal Blocks into the Wireway

4. Grasp the handle on the racking cam located on the top of the unit and pull out, rotating the cam until it stops (approximately 90 degrees). This will withdraw the unit far enough to separate the stabs from the vertical bus (Figure 22).
5. Grasp the racking cam handle and pull the unit out approximately 1-1/4 more inches. Now push the handle back toward the unit until it stops. The unit may be locked out in this position by inserting a padlock in the handle as shown (Figure 21A).
6. Separate pull apart terminals, or disconnect wires from terminal blocks, tag and secure within the motor control center wireway. To accomplish this, slide the wire and terminal blocks under the right hand side of the drawout unit. Refer to Figure 21B.
7. The drawout unit may now be easily removed from the frame.

 **DANGER**



**Hazardous Voltage.**  
Will cause death, severe personal injury, or property damage.

Energized vertical bus may be partially exposed through the access hole in the barrier when the unit is not fully inserted.

Use extreme caution when performing any wiring or maintenance with the unit withdrawn.

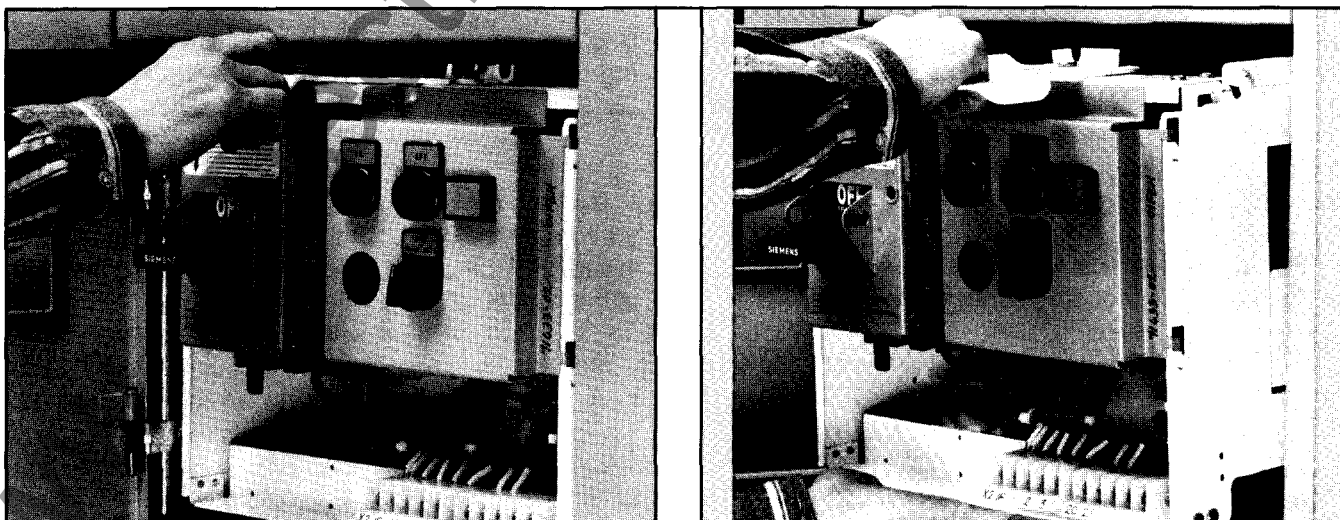

Figure 22. Draw-Out Unit (Pan Assembly) Removal

# Installation



8. If so equipped, the drawout unit pilot device panel (or SAMMS panel) may be released by loosening the captive screw a few turns, then swinging the panel to the right to gain access to components mounted behind it. Once the panel is opened to approximately 135 degrees, a detent will hold it in position. To release the detent, lift the panel slightly allowing it to reclose.
9. The drawout unit should be protected from abuse, dust, and moisture while it is out of the motor control center.

## Drawout Unit Addition

Drawout units may easily be added to the Siemens Motor Control Center to fill blank spaces. Each unit comes complete with horizontal support barrier, door, and hinges. The following is the installation procedure for these units.

1. Remove the cover(s) over the blank section(s) equal to the drawout unit height. (Steps A and B, Figure 23).
2. Horizontal drawout unit barriers (see Figure 2) are installed by sliding the rear tabs into mating slots in the vertical barriers (see Figure 2) and fastening the front into place with two self-tapping screws in the predrilled vertical channels (see Figure 2). (Step C, Figure 23).
3. Use the new door as a template to locate the positions of the hinges. Self-tapping screws in predrilled holes are used to bolt the hinges to the left hand corner channels. Remove or relocate any excess hinges left from the removal of the covers performed in Step 1 above. (Step D, Figure 23).
4. Remove the vertical bus barrier insert at the appropriate location for stab engagement.
5. Push the disconnecting means operating handle to the OFF position.
6. Close the racking handle and install the drawout unit onto the slide rails and push in until it stops. The unit may then be padlocked in this disengaged position.

7. Connect all power cables and control wires in agreement with unit wiring diagram and the instructions detailed in the Incoming Power and Load and Control Wiring sections of this manual.
8. Perform pre-energization checks outlined in Operation section of this manual.

 <b>DANGER</b>

<b>Hazardous voltage.</b> <b>Will cause death, severe personal injury, or property damage.</b> <b>Energized vertical bus may be partially exposed through the access hole in the barrier when the unit is not fully inserted.</b> <b>Use extreme caution when performing any wiring or maintenance with the unit withdrawn.</b>

9. Remove the padlock installed in Step 6 above. Pull the racking handle out until it stops, then push the unit inward until it engages the pin located on the underside of the horizontal unit barrier.
10. Rack the unit onto the vertical bus by pushing the racking handle to the left and inward as far as it will go.
11. Close the door and secure it with the quarter turn fasteners.

# Installation

12. Move the handle to the ON position. The control unit is now ready for operation.

13. Repeat steps 1 through 12 for each additional new drawout unit to be added.

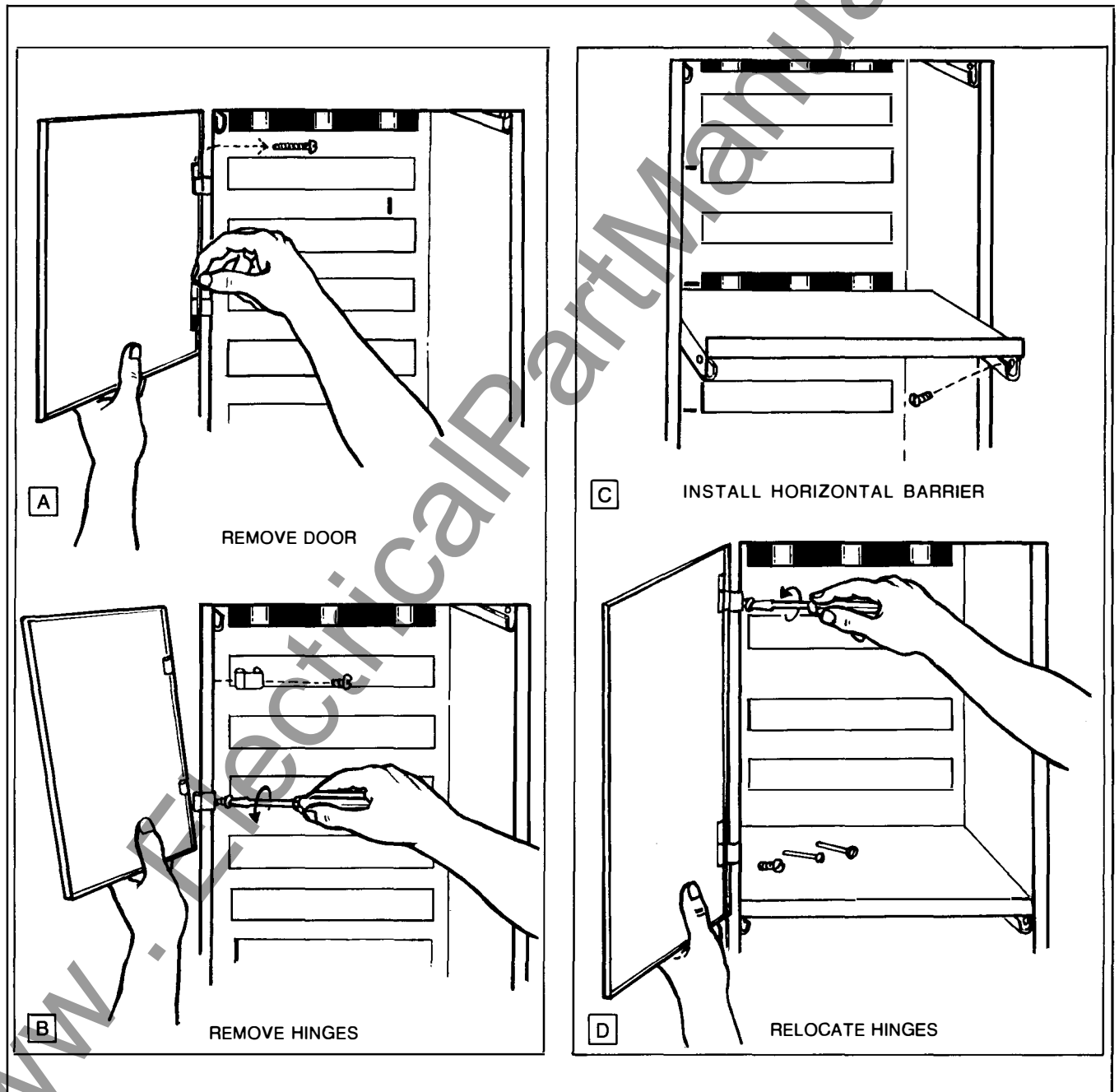



Figure 23. Draw-Out Unit Addition, Steps A, B, C, and D.



## Pre-energization Checks

After installation, field addition, or maintenance, perform the following checks before energizing equipment:

1. Compare all circuits for agreement with the wiring diagrams which are provided with the motor control center. Be sure that each motor is connected to its intended starter.
2. Check all connections for proper torque and be sure that inserts (refer to Figure 2) or automatic shutters are installed in all exposed openings in the vertical bus barriers (refer to Figure 2).
3. Inspect the motor control center for accumulation of dust or dirt. If required, clean the MCC as explained in the Maintenance section of this instruction manual.
4. Test the motor control center power circuit for possible short circuits and grounds. A dielectric test at 2 times the nominal system voltage plus 1000 volts applied for one minute between phases and from all phases to ground is the preferred method. The maximum allowable leakage current is 1.5 mA per 1000 test volts applied. If a high-pot tester is not available, then a megger test using a 500 or 1000 volt megger is a suitable second choice. The minimum allowable resistance measured from phase to phase and from phase to ground is one megohm. Be sure to disconnect any control devices, control power transformer, etc, from the circuit which could be damaged by the test voltage.
5. Manually exercise all switches, circuit breakers, contactors, magnetic devices, and other operating mechanisms several times to make certain they are properly aligned and operate freely. Some contactors are shipped with taped arc chutes or restraining devices to minimize vibration effects during shipment. Be sure that all such restraints have been removed. None of these devices must ever be blocked in the ON position. Check all electrical interlocks for proper contact operation. Check all mechanical interlocks for proper freedom and operation.

 <b>WARNING</b>

<b>Hazardous voltage.</b> <b>Can cause severe personal injury, death, or property damage.</b> <b>Dielectric or megger testing should only be conducted by qualified personnel. Refer to test device instructions for safety instructions.</b>

6. Some arc chutes are shipped separately packaged to reduce shipping damage. Make sure that all arc chutes are properly installed and secured on all contactors, relays, or switches.

 <b>WARNING</b>

<b>Hazardous voltage.</b> <b>Can cause death, serious injury, or property damage.</b> <b>Never operate any contactor, relay, or switch unless its arc chute or cover is properly installed and secured and undamaged.</b>

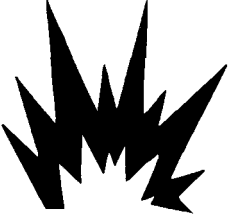
# Operation



7. Check all timers for proper interval setting and contact operation.
8. Check overload relay trip setting and verify that it is adjusted per the instructions given for the 3UA Overload Relay in this instruction manual.
9. Check all power circuit fuses and control fuses to verify that they are sized in accordance with the National Electrical Code application requirements. Classes K-9 and H fuses are not recommended.

 <b>WARNING</b>

<p><b>Explosive hazard.</b> <b>Installation of fuses of insufficient interruption rating can cause death, personal injury or property damage.</b></p> <p><b>To ensure proper coordination and sufficient capacity to interrupt the available fault current, always install replacement fuses with UL class, continuous current rating, type, and interrupting capacity identical to the original.</b></p> <p><b>Never defeat rejection mechanisms which are provided to prevent the installation of the wrong type of fuses.</b></p>

10. Current transformers to which customer devices will be connected, are shipped with their secondaries shorted. All shorting devices should be removed when the secondary connections to these transformers are completed. Make sure that the current transformer secondary is complete. Current transformers must not be energized with their secondaries open circuited.

11. Check all devices for missing or broken parts, proper spring tension, free movement, rusting or corrosion, dirt, and excessive wear. Make all necessary repairs.
12. Check all electrical relays, meters, and instruments to verify that connections are made properly and that the devices function properly. Verify that adjustable voltage and current trip mechanisms are set to the proper values.
13. Make sure that no fuses, overload relays, incomplete sequence relays, shunt trips, ground fault protection assemblies, electrical interlocks, or trip contacts from any of these devices are strapped, bypassed, or defeated in any manner.
14. Turn all circuit breakers and fusible switches to the OFF position.
15. Make sure that all barriers, braces, and shields are installed in the equipment as intended. If vertical bus isolation barriers are supplied, make sure that they are all properly seated between the vertical bus supports.
16. Check the integrity of all bus mounting means and cable connections to the bus. Make certain that field wiring is clear of line bus and physically secured to withstand the effects of the largest fault current which the supply system is capable of delivering. Make sure that control wires or power cables are not touching the power bus.
17. Verify that all ground connections have been properly made. If there is no ground bus, the sections of the motor control center which were shipped separately must be connected in such a way to assure a continuous grounding path.
18. Install covers, install units, close and secure doors, make certain that no wires are pinched and that all enclosure parts are properly aligned and secured.
19. Make sure the door interlocks on all disconnect operators are properly adjusted and secured. If adjustment is required, use the procedure explained in the Maintenance section of this instruction manual.
20. Disconnect any safety grounds which have been connected to the power bus.

## Energizing Equipment



 <b>WARNING</b>

<p><b>Hazardous voltage.</b> <b>Failure to check out this equipment prior to energization can cause severe personal injury or equipment damage.</b> <b>All pre-energization checks outlined in this instruction manual must be performed before the equipment is energized. This equipment should be energized by QUALIFIED PERSONNEL only.</b></p>

1. In order to minimize risk of injury or damage, or both, there should be no load on the motor control center when it is energized. Turn off all of the downstream loads, including those such as distribution equipment and other devices which are remote from the motor control center.
2. The equipment should be energized in sequence by starting at the source end of the system and working towards the load end. In other words, energize the main devices, then the feeder devices, and then the branch-circuit devices. With barriers (if applicable) in place, and unit doors closed and latched, turn the devices on with a firm positive motion. Protective devices that are not quick-acting should not be "teased" into the closed position.
3. After all disconnect devices have been closed, loads such as lighting circuits, starters, contactors, heaters, and motors, may be turned on to verify that the system operates as intended.

## Permissible Loading of Motor Control Centers

1. For motor control centers without main overcurrent protective devices, the total continuous load current through the horizontal bus should not exceed the current rating of the motor control center.
2. For motor control centers with a single main overcurrent protective device, the total continuous load current on the protective device should not exceed 80 percent of its ampere rating unless the device is rated to carry 100 percent of its ampere rating.
3. For motor control centers with multiple main overcurrent protective devices, the total continuous current through the horizontal bus should not exceed the current rating of the motor control center. The total continuous load current on each overcurrent protective device should not exceed 80 percent of its ampere rating unless the device is rated to carry 100 percent of its ampere rating.
4. For branch-circuit overcurrent protective device in a motor control center, the total continuous load current on the protective device should not exceed 80 percent of its ampere rating unless the device is rated to carry 100 percent of its ampere rating.
5. Unless a current limiting means is used in a series combination, the maximum short-circuit current rating of the entire motor control center is the smallest of the following:
  - a. the rating of the bus structure, or
  - b. the lowest rating of the motor control units, or
  - c. the lowest rating of the feeder tap units.

This motor control center rating is clearly indicated on the lead sheet located in the information packet.

 <b>WARNING</b>

<p><b>Hazardous voltage.</b> <b>Can cause death, severe personal injury, or property damage</b></p> <ol style="list-style-type: none"><li><b>1) Disconnect and lock-out incoming power and control voltage sources before beginning work on this or any other electrical equipment.</b></li><li><b>2) Check all power and control circuit terminals with a voltmeter to make certain that the equipment is totally de-energized.</b></li><li><b>3) Ensure that only QUALIFIED PERSONNEL be instructed and authorized to use the defeater mechanism to gain access to an energized compartment.</b></li><li><b>4) Never attempt to withdraw a drawout unit or disconnect any terminations when the defeater mechanism has been used to open a compartment door.</b></li></ol> <p><b>It is recommended that a safety ground be connected to the power bus after the system has been de-energized, and prior to working on the equipment. Follow the procedure outlined in the PRE-ENERGIZATION CHECK section of this manual before power is restored.</b></p>

For the safety of maintenance personnel as well as others who might be exposed to hazards associated with maintenance activities, the safety related work practices of NFPA 70E, part 11, should always be followed when working on electrical equipment. Maintenance personnel should be trained in the safety practices, procedures and requirements that pertain to their respective job assignments. This manual should be reviewed and retained in

a location readily accessible for reference during maintenance of this equipment.

The customer must establish a periodic maintenance program to ensure trouble-free and safe operation. The frequency of inspection, periodic cleaning, and preventive maintenance schedule will depend upon the operation conditions. NFPA Publication 70B "Electrical Equipment Maintenance" may be used as a guide to establish such a program. **A preventive maintenance program is not intended to cover reconditioning or major repair, but should be designed to reveal, if possible, the need for such actions in time to prevent malfunctions during operation.** The following items should be included in any maintenance checklist. For more details read the succeeding pages.

- \* General Inspection of the MCC
- \* Periodic Cleaning
- \* Tightening Torques
- \* Stab Fingers and Vertical Bus
- \* Circuit Breaker/Disconnect Operator
- \* Mechanical Interlocks

A specific checklist of routine preventative maintenance requirements is recommended for each item of equipment, as well as a log book to record the maintenance history.

## General Inspection of the MCC

1. Carefully inspect the doors, enclosure sides and deadfront surfaces over all units for excessive heat. As a general rule, temperature which the palm of the hand cannot stand for about 3 seconds may indicate trouble. Infra-red heat detectors are available for the purpose of detecting heat problems.
2. Inspect the motor control center a minimum of once each year, or more often as deemed necessary. Look for any moisture or signs of previous wetness or dripping inside the MCC. Look for any accumulation of dust or dirt. Clean as explained in the Periodic Cleaning section.
3. Loose electrical connections can cause overheating that can lead to equipment malfunction or failure. Loose bonding or grounding can compromise safety

and/or function. Terminal screws, lugs, bus connections, bonding and grounding connections should be inspected for tightness and retightened securely as required. Recommended tightening torques are shown in the Recommended Tightening Torque section of this manual. Fuse clips should be checked for signs of overheating, looseness, or inadequate spring pressure, and replaced if necessary. All terminals, connections, and conductors should be examined for evidence of overheating, corrosion, or pitting. Any parts found to be damaged should be replaced, using parts supplied or recommended by Siemens. Evidence of overheating may include discolored conductors, terminals or parts; or melted, charred or burned insulation.

4. Examine insulation on conductors for overheating or chafing against metal edges that could progress into an insulation failure. Any damaged conductors should be replaced. Replacement conductors should be rerouted, braced or shielded if needed to avoid similar damage in future operation. Temporary wiring should be removed or replaced by permanent wiring.
5. Operate each switch or circuit breaker several times to insure that all mechanisms are free and in proper working order. Check the operation of the mechanical safety interlocks provided with the operator (see section on Circuit Breaker/Disconnect Operator). Never attempt to operate a switch or circuit breaker by use of excessive force.
6. Visually inspect instruments and pilot lights. Replace defective pilot lights. Check instrument calibrations.
7. Check all devices for missing or broken parts, proper spring tension, free movement, rusting or corrosion, dirt, and excessive wear. Perform periodic maintenance on components as detailed in the component instruction books.

## Periodic Cleaning

Accumulation of dust and foreign material such as coal dust, cement dust, or lampblack must be removed from all control equipment and all surfaces must be wiped clean at regular intervals. Dirty, wet, or contaminated

parts should be replaced unless they can be cleaned effectively. Dust can collect moisture, causing voltage breakdown and it can reduce the effectiveness of heat sinks.

Control equipment parts should be cleaned by vacuuming or wiping with a dry cloth or soft brush. Use care to avoid damaging delicate parts. Liquid cleaners, including spray cleaners, are not recommended due to the possibility of residues. Compressed air is not recommended for cleaning because it will only redistribute contaminants on other surfaces, and may damage delicate parts. The inside bottom of the motor control center should also be cleaned, including removal of any hardware or debris, so that any new or unusual wear or loss of parts occurring after the inspection may be more readily detected during subsequent maintenance. Inspect the motor control center for any signs of previous wetness of dripping inside the controller.

Condensation in conduits or dripping from an outside source is a common cause of failure. Seal off any conduits that have dripped condensate, and provide an alternative means for the conduit to drain. Seal off any cracks or openings which have allowed moisture to enter the enclosure. Eliminate the source of any dripping on the enclosure and any other source of moisture. Replace and thoroughly dry and clean any insulating material which is damp or wet or shows any accumulation of deposited material from previous wettings.

## Stab Fingers and Vertical Bus

Look for wear of the tin or silver (optional) plating on the unit stab fingers and on the vertical bus at location where the unit stab fingers engage the vertical bus. The plating is part of the environmental protection system. Oxide and/or other films can form on exposed bus resulting in a poor contact.

These parts must be replaced when the plating is worn to the point where copper can be seen because contact resistance becomes higher, increasing the heat generated at the contact point which in turn may lead to arcing and possible bus flashover

# Maintenance

Lubricate the stab fingers with a light coating of Siemens contact lubricant number 15-171-370-002 before replacing drawout assemblies.

## Recommended Tightening Torques

When making bolted assemblies, the following considerations should be generally followed. The tightening torques are determined by the size of hardware used.

1. Metal-to-Metal - Apply standard tightening torque as listed:

**Table II. Recommended Tightening Torques**

Thread Size	Torque (lb.-in.)
8-32	14-20
10-32	20-30
1/4-20	40-60
5/16-18	168-228
3/8-16	240-360
1/2-13	480-600

2. Metal-to-Insert Molded in Compound Part - Apply approximately 2/3 of standard tightening torque.
3. Compound-to-Insert Molded in Compound Part - Apply approximately 1/2 of standard tightening torque.
4. Compound-to-Compound - Apply approximately 1/2 of standard tightening torque.

## Circuit Breaker Disconnect Operator

Operator mechanisms for circuit breakers through 125A and disconnect switches through 200A are hinged from the side of the unit and secured in place by a single captive screw. They may be swung open to access the

protective device by loosening the captive screw a few turns to release it from the unit top brace. The linear motion Operator mechanism shown in Figure 24 mounts directly to the face of the circuit disconnecting device and the plastic handle extends through the unit door to allow the device to be safely operated. The operator is provided with three mechanical safety interlocks to perform the following functions:

### 1. Operator-Unit Interlock:

The operator-to-drawout unit interlock prevents withdrawal or insertion of the control unit with the handle in the "ON" position. When the handle is in the "ON" position, the operator driver, (Figure 24, Item 1) extends into the racking handle assembly (Figure 25, Item 1). This also prevents movement of the latching mechanism (Figure 25, Item 2), locking the unit so that it may neither be inserted or withdrawn. When the handle is in the "OFF" position, the racking handle is free to move, thus allowing easy withdrawal and insertion of the drawout unit.

### 2. Padlocking:

The handle may be locked in the "OFF" position (Figure 26) by installing one to four padlocks in the locations shown. With one or more padlocks installed, the handle is prevented from moving to the "ON" position by interference between the padlock and the handle.

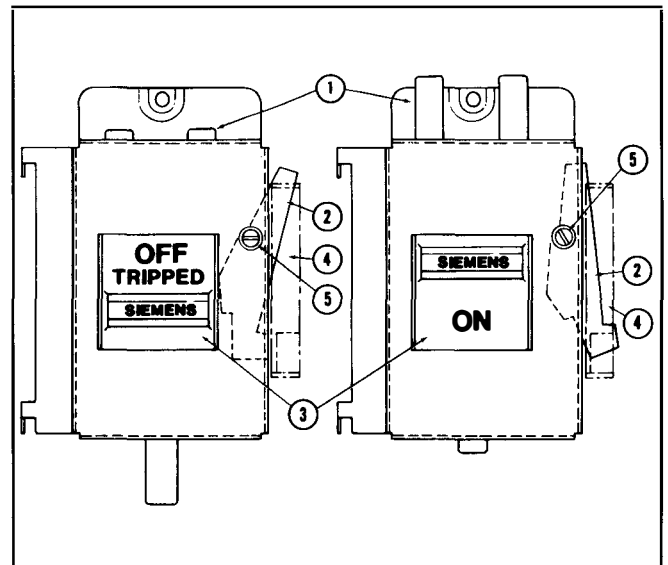

**Figure 24. Linear Motion Operator Mechanism.**

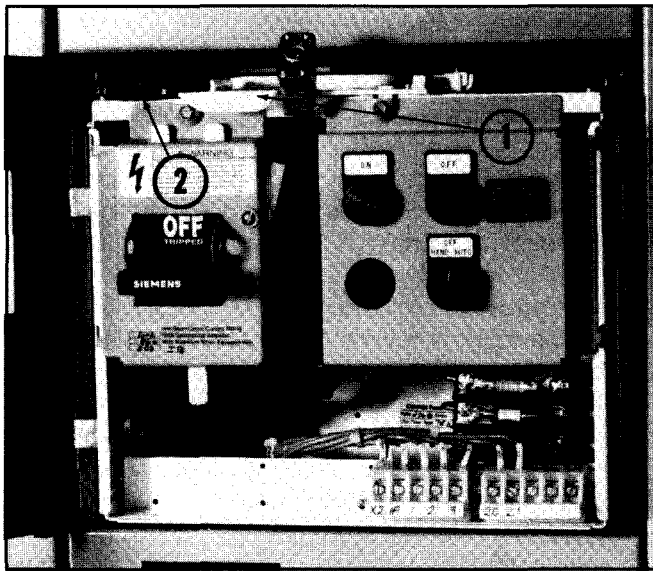

Figure 25. Padlocking the Pan Brace Assembly

### 3. Door-Operator Interlock:

The door-to-operator interlock prohibits closing or opening the control unit door except when the handle is in the "OFF" position. As the handle moves to the "ON" position, the interlock lever (Figure 24, Item 2) pivots behind the door mounted "J" shaped bracket thus preventing opening of the control unit door.

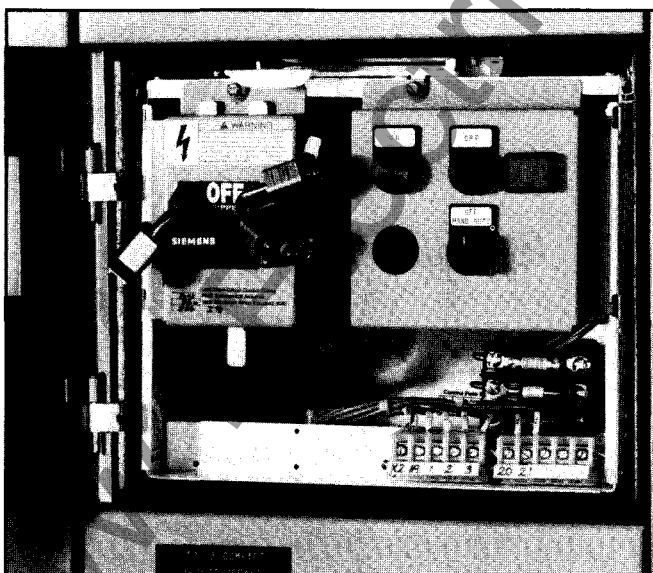

Figure 26. Padlocking the Handle in the "OFF" Position

A provision is made for **Qualified Persons** to defeat the door-operator interlock when the handle is in the "ON" position. This is accomplished by turning the defeater screw (Figure 24, Item 5) counterclockwise approximately 1/8 turn until the door is released. To reclose the door, gently hold the door closed while turning the defeater screw counterclockwise until the door is felt to close against the structure frame. Release the defeater screw and secure the 1/4 turn door fasteners.

This safety interlock also serves to prevent inadvertent closing of the protector when the door is open. Authorized personnel may defeat the interlock in this situation by pushing and holding the exposed upper portion of the interlock arm to the left. This releases the interlock so that the protective device may be turned "ON".

## Adjustment Notes

No field adjustment to the door interlock mechanism should be necessary under normal operating conditions. However, should adjustment become necessary as a result of mechanical damage or wear, the following procedure is recommended.

1. With the protector in the "OFF" position, the latching mechanism (Figure 25, Item 2) fully extended, and the unit door open, defeat the interlock by pushing the top of the lever (Figure 24, Item 2) to the left and turn breaker "ON" and "OFF" several times. If the protector fails to turn "ON" or if excessive operating resistance is experienced, turn protector "OFF". Withdraw the unit and inspect for misalignment of the operator extension(s) or the driver (Figure 24, Item 1) and the racking handle assembly (Figure 25, Item 1). Make necessary adjustments to correct any misalignment.
2. With the drawout unit reinstalled in the motor control center, close and secure door. Turn protector "ON". If operating difficulty persists and protector fails to turn "ON", open unit door. Inspect the door mounted portion of the interlock assembly for damage or distortion. Inspect the interlock lever (Figure 24, item 2) mounted on the right side of the operator for damage, freedom of movement, and its ability to rest firmly against the boss on the plastic handle without assistance. If damage or unusual wear are detected, all affected parts must be replaced.

- If operating difficulty persists, unlatch the 1/4 turn fasteners and open the door then slowly close it observing the point of contact between the interlock lever on the operator (Figure 24, Item 2) and the door mounted portion of the interlock. The ramp on the "J" shaped bracket mounted on the door should first engage the movable interlock lever on the operator at a point approximately 1/16" below the top right corner of the interlock lever. If the point of engagement does not occur at this point, gently bend the pointed extension of the door mounted portion up or down slightly to the proper position. Before making this adjustment, make sure the plastic handle is centered in the door cut-out when the door is closed.

## Mechanical Interlock Adjustment

Siemens motor control centers which contain reversing, multispeed or reduced voltage motor starters may employ mechanical interlocking between contactors in the starter units. Two contactors of the same size or two contactors of different sizes may be mechanically interlocked depending on the type of motor starter. The combinations of interlocked contactors which can be supplied is shown in Table IV. Mechanical interlocking is accomplished with the interlock mechanisms shown in Figure 27A and 27B which mounts between two adjacent contactors. Dimension "X" shown in Figure 27A and 27B is factory set to the dimension shown in Table IV. The contactors and mechanical interlock mechanism should be checked periodically and adjusted if necessary to ensure that the mechanical interlock functions properly. This procedure should be performed as outlined in the following steps.

### 3TB44 to 3TB44 Contactors: (Refer to Figure 27A)

- Disconnect and lock-out all incoming power and control voltage sources to the unit which contains the mechanical interlock assembly to be checked.
- Remove the arc chutes from both contactors by depressing the two slotted fasteners and rotating 1/4 turn.
- Depress the movable contact carrier of one contactor. The movable contact carrier of the other contactor should be blocked open, unable to close.

Table IV. Combinations of Mechanical Interlocks

1st Contactor Catalog No.	2nd Contactor Catalog No.	Dimension "X" (mm)
3TB44	3TB44	2
3TB44	3TF46	0
3TF46	3TF46	0
3TF46	3TF48	8
3TF48	3TF48	8
3TF48	3TF52	16
3TF52	3TF52	16
3TF52	3TF56	16
3TF56	3TF56	0

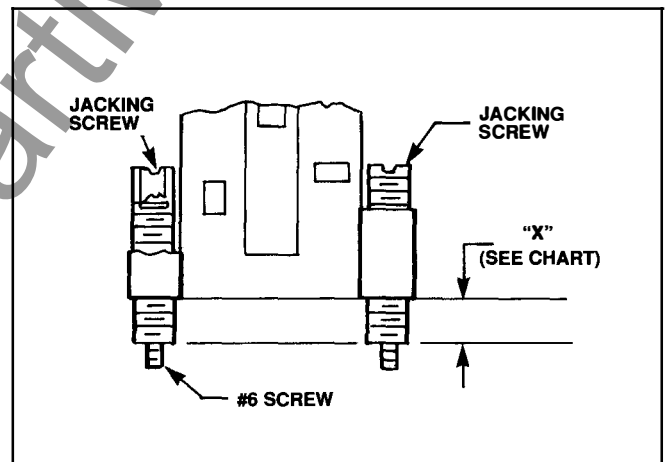

Figure 27A Mechanical Interlock-3TB44 to 3TF44

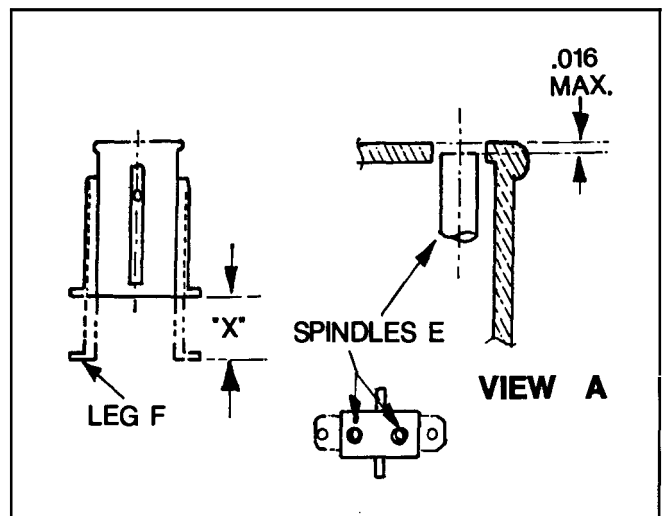

Figure 27B Mechanical Interlock-3TB44 to 3TF44, All 3TF to 3TF

Repeat the process in the reverse order starting with the other contactor first. The second contactor should be blocked open in each case.

4. To check the interlock adjustment, loosen the two #6 screws on the interlock. The interlock can be raised or lowered using a large blade screw driver by turning both jacking screws (see Figure 27A) alternately with 1/2 turn; clockwise raises the interlock and counter-clockwise lowers the interlock. Make sure that the "X" dimension is maintained equal for both jack screws. Set the "X" dimension to the value shown in Table IV.
5. Tighten the two #6 screws.
6. Reassemble arc chutes on respective contactors and secure in position by depressing the slotted fastener and rotating 1/4 turn.

### **3TB44 to 3TF46, All 3TF to 3TF:** (Refer to Figure 27B)

1. Disconnect and lock out all incoming power and control voltage sources to the unit which contains the mechanical interlock assembly to be adjusted.
2. Remove the screws which secure legs F to the baseplate.
3. Set dimension "X" of legs to the dimension shown in Table IV.
4. Re-attach legs F to the baseplate using the screws removed in Step 2.
5. Turn both of the screw spindles E until they are flush to .016" below the surface of the interlock case.
6. Check the function of the mechanical interlock by pushing on the screw spindles E. You should not be able to push both spindles down at the same time.

## **Maintenance After A Fault Has Occurred**

The excessive currents occurring during a fault may result in component or bus damage due to mechanical distortion, thermal damage, metal deposits, or smoke. After a fault, repair the cause of the fault, inspect all equipment per NEMA Standards Publication No. ICS 2-1978 Part ICS 2-302 and make any necessary repairs or replacements prior to placing the equipment into service again. The following procedure is recommended for this inspection.

### **Bus:**

Retighten all bus connections. Replace burnt or melted bus or bus with melted, worn or damaged plating. Replace all insulators showing deterioration or deposits.

### **Enclosure:**

Inspect the enclosure and doors for evidence of damage such as deformation, displacement of parts or burning. Extensive damage will require replacement of the entire controller.

## **Disconnecting Means**

1. Circuit Breakers: Examine the circuit breaker for evidence of possible damage. If there is no apparent evidence of damage, the breaker may be reset and turned "ON". If it is suspected that the circuit breaker has opened several short circuits or if there are signs of possible deterioration, replace the breaker or subject it to the test described in Para. AB1-2.38 of the NEMA Standards Publication for "Molded Case Circuit Breakers" before restoring it to service.

2. **Disconnect Switch:** The external operating handle must be capable of opening the switch after a fault. Replace the switch if the external operating handle fails to open it or if visual inspection after opening indicates deterioration beyond normal wear, such as overheating, contact blade or jaw pitting, charring, or insulation breakage.
3. **Fuse Holders:** Replace fuse holders if the insulating mounts, barriers, or fuse clips show signs of deterioration, heating, distortion, or looseness.
4. **Operating Handle:** The disconnecting means must be replaced if the operating handle fails to open and close it. The door interlock must be inspected and its proper function verified prior to restoring the controller to service.
5. **Stab Fingers:** (Figure 28) Inspect stab fingers as instructed under Stab Fingers Section and Vertical Bus Section and replace if necessary.

## Terminals and Internal Conductors

Replace all damaged parts which show evidence of discoloration, melting or arcing damage.

## Motor Starter

1. **Contactors:** Replace the contacts and contact springs if the contacts are welded or show heat damage, displacement of metal, evidence of binding in the guides, or wear in excess of wear allowance. If deterioration extends beyond the contacts, replace the contactor. Examples of such deterioration include evidence of arcing on the contactor moldings and insulation damage. Arc chutes must be in place and secured prior to operating contactor.

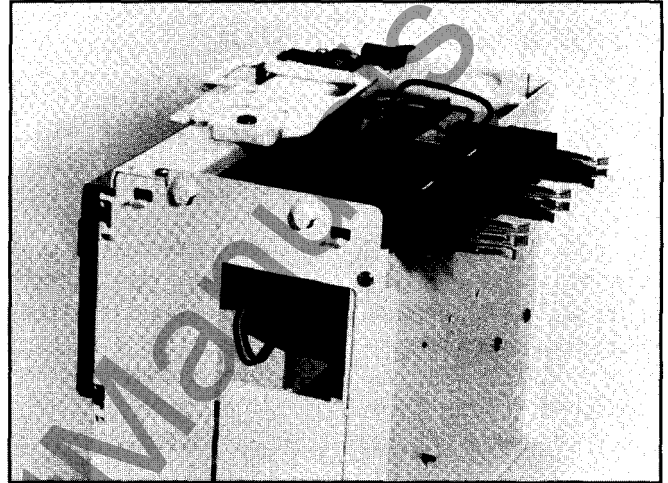

Figure 28. The Stab Assembly

2. **Overload Relays:** a) Any indication of an arc striking or burning the overload relay may require replacement. b) Contact operation must be verified by electrically or mechanically tripping and resetting the relay even if there is no visual indication of damage that would require replacement.
3. **Fuses:** Always replace all three fuses even though only one or two are open circuited since internal damage suffered by fuses not replaced could result in nuisance shut down later.  
NOTE: To replace side-mounted fuses supplied with 30 and 60 amp fusible disconnects, a special fuse removal tool is provided. To use this tool, refer to Figure 29. Remove the three fuses in sequence starting with the front (A phase) fuse. Pry out the bottom of the fuse by inserting the tool between the fuse barrel and the left hand unit side and moving the tool handle to the left. Then complete fuse removal by grasping the fuse and pulling it out of the upper clip. Repeat for the second and third fuses.
4. Perform to the Pre-Energization Checks procedures detailed on Page 26 and 27 herein, before restoring the equipment to service.

## Adjustment of Sentron™ Type ETI Instantaneous Trip Motor Circuit Interrupter (1A-125A)

ETI instantaneous trip motor circuit interrupters are supplied as standard with size 1 through size 3 motor starters. The motor circuit interrupter continuous current rating should not be less than 115% of motor full load current (MFLC). The MFLC is obtained from the motor nameplate or from Table 430-150 of the NEC (1987). Use the following procedure to adjust the instantaneous trip setting.

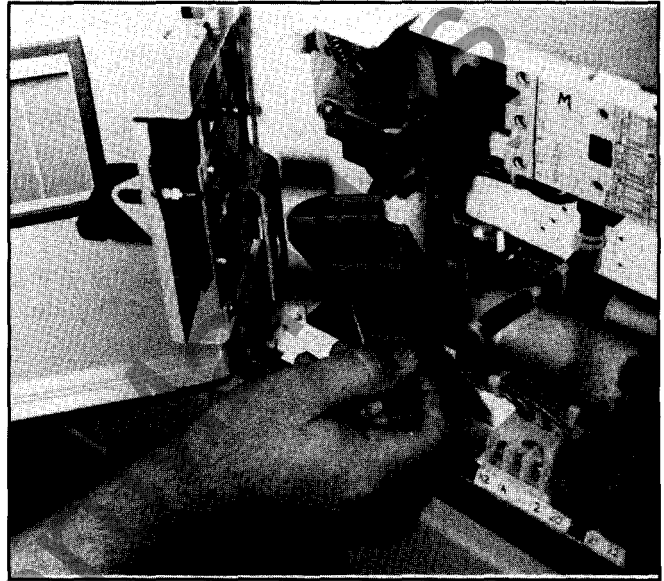

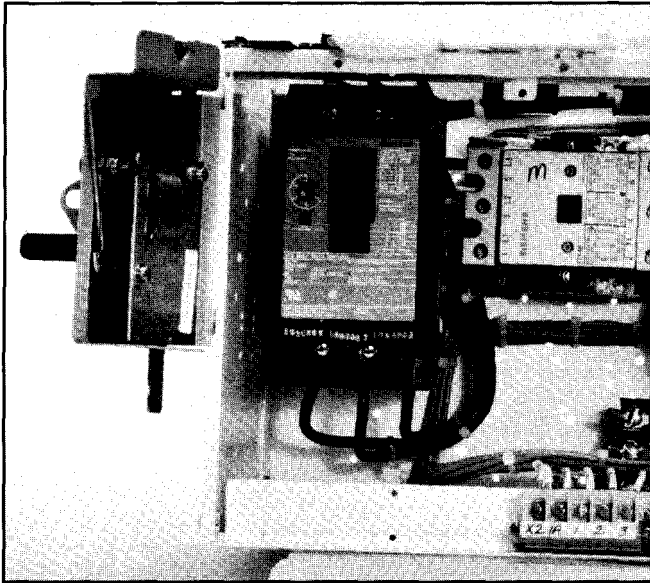

Figure 29. Using the Fuse Removal Tool.

 <b>WARNING</b>

<b>Hazardous voltage.</b>
<b>Can cause death, severe personal injury, or property damage.</b>
<b>Disconnect and lock-out all power and control voltage sources supplying the motor circuit interrupter before adjusting trip setting or performing any other maintenance operations.</b>

1. Turn the operating handle to the OFF position and open the unit door.
2. Loosen the captive screw which secures the operator mechanism to the unit top brace and swing the operator out of the way, exposing the adjustment dial on the motor circuit interrupter.
3. The instantaneous setting is determined by multiplying MFLC by 13. Select the closest setting to (13 times MFLC) which does not exceed (13 times MFLC). The label on the face of the circuit breaker shows the continuous rating and adjustment points for the installed breaker.
4. Adjust the trip setting by rotating the adjustment dial to the position selected in step 3 above.
5. Making sure that both the motor circuit interrupter and the operator are in the "OFF" position, swing the operator back into position over the front of the interrupter. Be sure that the toggle on the interrupter engages the opening in the driver plate on the operator. Secure by tightening the captive screw.



**Figure 30. Operator Hinge Open to Expose adjustment on ETI Motor Circuit Interrupter.**

### Adjustment of Circuit Breakers With Adjustable Instantaneous Trip (125A-1200A)

These circuit breakers are supplied with Size 4 through Size 7 motor starters. Use the following procedure to adjust the instantaneous trip setting:

1. Turn the operating handle to the OFF position and open the unit door.
2. If a linear operator is provided, remove the four screws which mount the operator to the two steel brackets on the face of the circuit breaker. Slip the operating handle assembly forward off the face of the circuit breaker. This exposes one adjustment dial per phase.
3. Select the required trip setting from the label on the operator for the particular circuit breaker based on 13 times MFLC as explained in adjustmentStep 3 for the motor circuit interrupter.

4. Set all three adjustment dials to the trip setting selected in Step 3.
5. Re-install the operating handle assembly to the circuit breaker using the reverse procedure to the procedure explained in Step 2.

### Field Testing of Circuit Breakers

A test can be performed using the procedure outlined in the following discussion to verify that a circuit breaker trip mechanism is functioning.

1. Wire the three circuit breaker poles in series.
2. Connect the series combination of breaker poles to a variable low voltage high current power source.
3. Gradually increase the voltage from "0" until the circuit breaker trips. If the circuit breaker fails to trip when the test current reaches 150% of the largest trip setting, the trip unit is not functioning properly and the circuit breaker requires replacement.

# 3UA Overload Relay

## 3UA Overload Relay

For proper overload relay coordination, the cables on the load side of the overload relay should be sized in accordance with the tables in Article 310 of the National Electrical Code. The wire for motors with full load currents of 100 amperes or less may be selected from the 60° C or 75° C column. Select wire from the 75° C column when the motor current is greater than 100 amperes. When conditions dictate the use of cables larger than these, the relay tripping time may be affected. Another condition which may affect tripping is a long acceleration time such as that caused by a motor driving a high inertial load. If either of these conditions exists, consult Siemens for overload relay application instructions.

## Description

The 3UA three phase thermal overload relay is a NEMA Class 10, directly heated, front adjustable, ambient temperature compensating, bimetallic device. The relay is supplied with one normally closed contact (Form B) for opening the control circuit in case of thermal trip and one normally open contact (Form A) for wiring to an alarm or other device.

The relay for NEMA size 1 through size 4 starters mounts directly to the contactor. The relay for NEMA size 5, 6, and 7 starters is separately mounted and indirectly heated from the secondary of current transformers.

## Single Phasing Protection

In addition to motor overload protection, the internal trip mechanism provides motor single phase protection. Referring to Figure 31, Curve 3 shows the normal three phase time-current tripping relationship. The relay senses a loss of phase condition and shifts the time-current tripping response curve to the left as shown by Curve 2. As a result of this curve shift and the higher single phase current, the tripping time of the overload relay will be reduced.

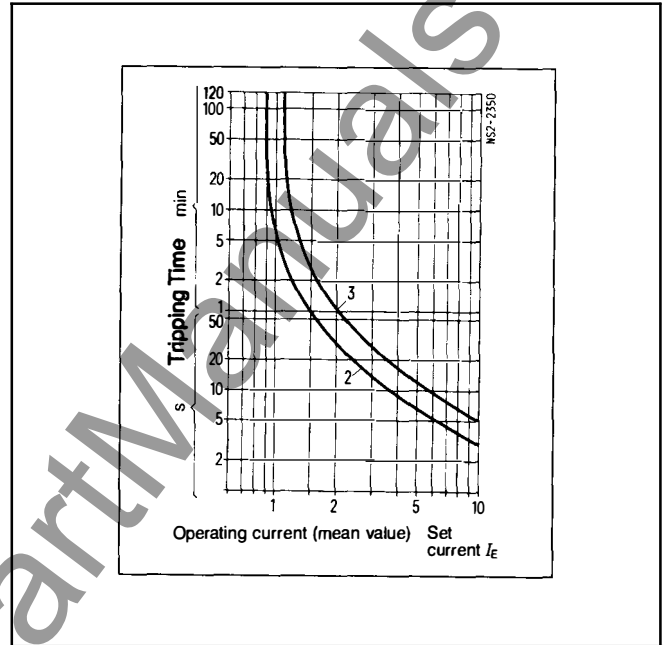

Figure 31. 3UA Overload Relay Time-Current Tripping Curves

## Manual or Automatic Reset

The 3UA overload relay is set for HAND reset operation when shipped from the factory. The relay may be set for AUTO operation by depressing and turning the blue reset button counterclockwise to the position marked "A". See Figure 32.

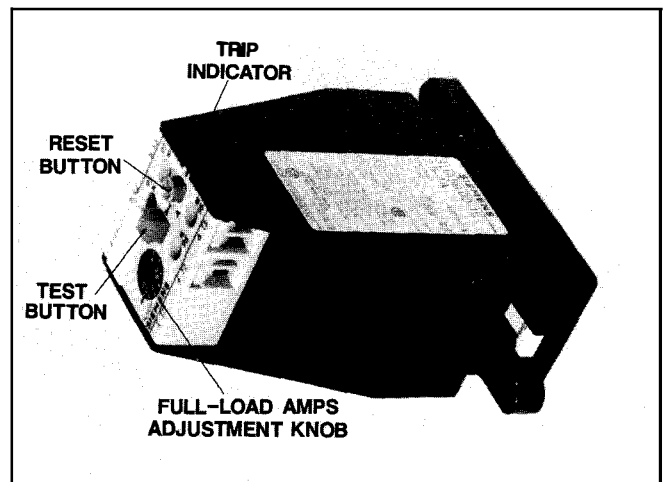



Figure 32. 3UA Overload Relay

## 3UA Overload Relay

 <b>WARNING</b>

<p><b>Automatic reset.</b></p> <p><b>Can cause severe personal injury, death, or property damage.</b></p> <p><b>Do not use automatic reset with two wire control or any other application where automatic reset restores power to the motor endangering either personnel or equipment.</b></p>

### Overload Relay Selection And Adjustment

The overload relays for use in Siemens Motor Control Centers may be selected from Tables V, VI, VII, and VIII. The following information must be known before the selection can be made.

1. Starter size (NEMA size 1, 2, 3, 4, 5, 6 or 7.).
2. Motor nameplate full load current.
3. Motor name plate service factor and temperature rise.

Markings on the adjustment dial denote current in amperes. The dial should be set at the actual motor full load current marked on the motor nameplate (FLA), if the motor nameplate is marked with a service factor of not

less than 1.15 or with a temperature rise not greater than 40° C. For all other motors, the dial setting should be .92 times FLA (See Table IX.). Where these settings are not adequate to start the motor or carry the load, the National Electrical Code allows the setting of the 3UA overload to be increased 1.12 times FLA for motors marked with service factors not less than 1.15 or with a temperature rise not greater than 40° C; the setting for all other motors may be increased to 1.04 times FLA (See Table X.).

### Procedure For Checking Nuisance Overload Tripping

The following steps need to be taken when the overload relay consistently trips with the motor running.

1. Make sure that all connections to the overload relay are tight. Check for and correct any phase unbalance of motor currents.
2. Verify the dial adjustment. See Figure 32. The setting should **not** be greater than the value shown in Table IX.
3. Verify that the proper overload relay has been selected per **actual** motor running current. See the overload relay selection tables. If the actual motor running current is larger than the motor nameplate marking, the motor is overloaded. For a motor with a service factor greater than 1.0, multiply the rated motor full load current by the service factor to determine if the motor is overloaded.
4. Adjust the overload dial to a higher setting until tripping ceases. This setting is not to exceed the value shown in Table X.
5. The overload relay should be replaced if it still trips after Steps 1 through 4 have been completed. If the value in Table X. was not attainable with the replaced relay, the next higher trip range of the same frame size should be installed.

# 3UA Overload Relay

Table V.

NEMA Starter Sizes 1,2,3 and 4			
Lead Sheet Designation	Relay Range	Catalog Number	Used With Contactor
3COA	.10 - .16	3UA52 00 - 0A	3TB44
3COC	.16 - .25	3UA52 00 - 0C	3TB44
3COE	.25 - .40	3UA52 00 - 0E	3TB44
3COG	.40 - .63	3UA52 00 - 0G	3TB44
3COJ	.63 - 1.00	3UA52 00 - 0J	3TB44
3COK	.80 - 1.25	3UA52 00 - 0K	3TB44
3C1A	1.00 - 1.60	3UA52 00 - 1A	3TB44
3C1B	1.25 - 2.00	3UA52 00 - 1B	3TB44
3C1C	1.60 - 2.50	3UA52 00 - 1C	3TB44
3C1D	2.00 - 3.20	3UA52 00 - 1D	3TB44
3C1E	2.50 - 4.00	3UA52 00 - 1E	3TB44
3C1F	3.20 - 5.00	3UA52 00 - 1F	3TB44
3C1G	4.00 - 6.30	3UA54 00 - 1G	3TB44
3C1J	6.30 - 10.0	3UA54 00 - 1J	3TB44
3C2A	10.0 - 16.0	3UA54 00 - 2A	3TB44
3C2B	12.5 - 20.0	3UA54 00 - 2B	3TB44
3C2C	16.0 - 25.0	3UA54 00 - 2C	3TB44
3C2D	20.0 - 32.0	3UA54 00 - 2D	3TB44
3C2K	25.0 - 36.0	3UA54 00 - 2Q	3TB44
3C2L	16.0 - 25.0	3UA58 00 - 2C	3TF46 3TF48
3C2M	20.0 - 32.0	3UA58 00 - 2D	3TF46 3TF48
3C2E	25.0 - 40.0	3UA58 00 - 2E	3TF46 3TF48
3C2F	32.0 - 50.0	3UA58 00 - 2F	3TF46 3TF48
3C2T	40.0 - 57.0	3UA58 00 - 2T	3TF46 3TF48
3C2P	50.0 - 63.0	3UA58 00 - 2P	3TF46 3TF48
3C2V	57.0 - 70.0	3UA58 00 - 2V	3TF46 3TF48
3C2U	63.0 - 80.0	3UA58 00 - 2U	3TF46 3TF48
3C2H	55.0 - 80.0	3UA62 00 - 2H	3TF52
3C2W	63.0 - 90.0	3UA62 00 - 2W	3TF52
3C2X	80.0 - 110	3UA62 00 - 2X	3TF52

Table VI.

NEMA Starter Size 5 (With 300:5 Current Transformers)		
Lead Sheet Designation	Full Load Current of Motor (FLA)	Catalog Number
3B1A	60.0 - 96.0	3UA59 00 - 1A
3B1B	75.0 - 120.0	3UA59 00 - 1B
3B1C	96.0 - 150.0	3UA59 00 - 1C
3B1D	120.0 - 192.0	3UA59 00 - 1D
3B1E	162.0 - 258.0	3UA59 00 - 1E
3B1F	210.0 - 270.0	3UA59 00 - 1F

Table VII.

NEMA Starter Size 6 (With 600:5 Current Transformers)		
Lead Sheet Designation	Full Load Current of Motor (FLA)	Catalog Number
3B1A	120.0 - 192.0	3UA59 00 - 1A
3B1B	150.0 - 240.0	3UA59 00 - 1B
3B1C	192.0 - 300.0	3UA59 00 - 1C
3B1D	240.0 - 384.0	3UA59 00 - 1D
3B1E	324.0 - 516.0	3UA59 00 - 1E
3B1F	420.0 - 540.0	3UA59 00 - 1F

Table VIII.

NEMA Starter Size 7 (With 1000:5 Current Transformers)		
Lead Sheet Designation	Full Load Current of Motor (FLA)	Catalog Number
3B1A	200.0 - 320.0	3UA59 00 - 1A
3B1B	250.0 - 400.0	3UA59 00 - 1B
3B1C	320.0 - 500.0	3UA59 00 - 1C
3B1D	400.0 - 640.0	3UA59 00 - 1D
3B1E	500.0 - 800.0	3UA59 00 - 1E
3B1F	640.0 - 810.0	3UA59 00 - 1F

# 3UA Overload Relay

## Field Testing

3UA overload relays are subjected to 100% calibration testing at the factory. If tests are to be performed on an overload relay in the field, use the following procedure:

1. Connect 4 feet of wire to each field wiring terminal of the overload relay. The wire should be the smallest size having an ampacity of at least 125% of the maximum current element rating. The maximum current element rating is equal to 125% of the maximum overload trip setting.
2. Connect the overload relay to a 3 phase variable current test power source. If a 3 phase test source is not available, wire the three overload phases in series and use a single phase test power source.
3. The overload relay must be tested at an ambient temperature between -20° C and +55° C (-5° F to +131°F).
4. Energize the relay with test current between 125% and 1000% of the overload relay trip setting and measure the time to trip. The test trip time should be approximately equal to the average tripping time shown on curve (3) in Figure 31.
5. A short cooldown time must be allowed before the overload relay can be reset and further tests performed.
6. The overload relay may be tested with single phase test current applied to individual poles. In this case, test tripping time should be approximately equal to the average tripping time shown on curve (2) in Figure 31.
7. A test pushbutton is provided on each overload relay. Depressing this pushbutton (red in color) causes the overload relay contacts to change state.

Table IX.

Maximum Settings of Overload Relays	
	Maximum Setting Multiply Motor FLA by:
Motor service factor equal to or greater than 1.15	1.00
Motor temperature rise less than or equal to 40°C.	1.00

Table X.

Maximum Settings of Overload Relays When the Values Indicated in Table IX Are Insufficient to Start	
	Maximum Setting Multiply Motor FLA by:
Motor service factor equal to or greater than 1.15	1.12
Motor temperature rise less than or equal to 40°C.	1.12
All other motors	1.04

# Troubleshooting

In the unlikely event that operating problems are encountered, use the following troubleshooting chart to isolate the cause of the problem and find the remedy. If the corrective action given in the chart fails to correct the difficulty, consult your field sales representative.

The following information is required if it is necessary to write Siemens relative to the equipment problem.

1. Manufacturer's order number and part number, if available.
2. Nameplate data on contactor or controller.
3. Duty cycle and any details of operation.
4. Length of time in service and approximate total number of operations.
5. Voltage, current and frequency.
6. Description of any problem.
7. Any other pertinent information, such as drawing, layout and schematic number.

Problem	Probable Causes	Corrective Action
Doors will not close or are out of alignment.	Enclosure is not bolted down tightly on perfectly level surface.	Using level, add shims as necessary, and tighten anchoring bolts.
	Enclosure sprung out of shape.	Straighten or repair cubicle.
	Door hinges not properly adjusted.	Remove door hinges. Add or subtract shims as necessary.
Contactor will not close	Control circuit or power fuse blown or circuit breaker tripped.	Inspect fuses, replace if blown. Reset circuit breaker.
	Incoming power line not energized.	Close feeder circuit breakers or tie switch.
	Magnet coil defective.	Check magnet operation, replace coil as necessary.
	*Master relay (MR) defective.	Check and replace if defective.
	Control power transformer defective.	Check and replace if necessary.
	Overload relay tripped or defective.	Check and replace if necessary.
	Missing jumpers, loose connections, remote connections, etc.	Check wiring diagram carefully to make sure that all external or alternate connections have been made satisfactorily. This is especially true where remote protective or control devices are used.

\*Not supplied on all starters.

# Troubleshooting

Problem	Probable Causes	Corrective Action
Contactor chatter or hum	Loose connection in control circuit.	Tighten connections in control circuit.
	*Defective master relay.	Check relay, replace if necessary.
	Defective coil.	Check main coil, replace if necessary.
	Low control voltage.	Check line voltage.
	Corroded or dirty magnet pole faces.	Clean or replace magnet assembly.
Contacts overheating	Loose connections.	Tighten connections.
	Contacts not making firmly.	Check for weak or deformed contact spring, replace if necessary.
	Dirt or foreign matter on contact surface.	Clean contacts.
	Contact tip eroded.	Replace contacts.
Overload relays trip during starting or soon after motor is up to speed.	Motor overloaded.	Limit starting load and running load to motor capabilities.
	Motor being started too frequently at close intervals.	Jogging and starting operations must be limited to capabilities of the motor and control. Check starting limitations in motor instruction manual before repeated starts.
	Excessive motor acceleration time.	The starting of high inertia loads may not permit the use of standard overload relay application. Where accelerating time approaches 12 seconds or more, special overload relay by-pass devices and circuits would usually be required. Contact Siemens regarding such problems and supply complete data on locked-rotor starting current and total accelerating time under maximum load conditions.

\*Not supplied on all starters.

# Troubleshooting

Problem	Probable Causes	Corrective Action
Overload relay trips during starting or soon after motor is up to speed.	Low line voltage.	Line voltage should be maintained between +10% of motor nameplate voltage.
Overload relay trips during motor operation.	Motor being overloaded.	Reduce load or correct conditions causing overload.
	Overload relay not adjusted to motor capabilities.	Adjust relay setting in accordance with instructions for the overload relay. Adjustment should correspond to thermal rating of the motor, including temperature rise, duty and service factor.
	Incorrect relay or relay set incorrectly.	Replace with correct relay selected from overload relay section of this manual.
	Relays set incorrectly.	Set in accordance with relay instructions.
Overload relay fails to trip on overload current.	Relay tripping mechanism jammed.	Replace relay.
	Incorrect relay or relay set incorrectly.	Check relay selection and adjustment per overload relay instructions.
	*Current transformers with improper ratio or with short-circuited secondary terminals.	Current transformers must have a step-down ratio to correspond to full load motor current and relay selection. Protective jumpers may be provided at current transformer secondary terminals or on terminal block connections to guard against open transformer secondary circuit, and jumpers must be removed before placing equipment in operation.
Blowing of motor power fuses	Short circuit on the load side of the motor fuses.	Use megger and other test instruments to locate fault and correct.

\*Not supplied on all starters.

# Troubleshooting

Problem	Probable Causes	Corrective Action
Blowing of motor power fuses	Jogging or too frequent starting.	On frequent starting, fuses accumulate abnormal heat and cool more slowly than do overload relays. Since fuses more closely follow cooling and heating of motor windings, successive starting operations must be limited to the safe capacity of the motor to prevent fuse blowing from this cause. Check size rating on fuse against motor full load currents and service factor.
	Fuses internally damaged because of improper handling.	Motor power fuses may be damaged, dropped or roughly handled. Replace with fuse of same type, rating, and voltage.
Blowing of primary control transformer fuses	Shorted primary winding in control transformer.	Replace or repair transformer.
	Fuse may be "open" due to rough handling before installing.	Replace with fuse of same type, rating, and voltage.
	Secondary fuses not properly coordinated.	Melting characteristics of secondary fuse should not intersect melting characteristic of primary fuse. Rating of standard NEC fuse should not exceed twice the secondary current rating.
Blowing of secondary control transformer fuses.	Abnormal current or short circuit in control.	Check for faulty operation of long wipe economizing contacts, if supplied, shorted magnet coils, shorted rectifiers, if supplied, grounds, loose or bent connections, mechanical binding in relay and contactor mechanisms, excessive operations and incorrect secondary terminal connections.

## Instruction Sheet References

---

NEMA Size 1 Contactors .....	CC9001
NEMA Size 2 Contactors .....	CP9002
NEMA Size 3 Contactors .....	CP9003
NEMA Size 4 Contactors .....	CP9004
NEMA Size 5 Contactors .....	CP9005
NEMA Size 5-7 Contactors .....	CP3045
Auxiliary Contact Blocks .....	CP3080
P22 Pushbuttons .....	CP3310
P22 Pilot Lights .....	CP3312
P22 Selector Switch .....	CP3313
Renewal Parts—Siemens Motor Control Center .....	CC5002
ITE® Sentron™ Circuit Breakers .....	.2.0-1A
Control Relays .....	CP3400, CP3401

[www.ElectricalPartManuals.com](http://www.ElectricalPartManuals.com)

[www.ElectricalPartManuals.com](http://www.ElectricalPartManuals.com)

[www.ElectricalPartManuals.com](http://www.ElectricalPartManuals.com)

## Sales Offices

<b>Alabama</b> Birmingham (205) 879-7030 Mobile (205) 928-0822 Montgomery (205) 279-6321	<b>Florida</b> Ft. Lauderdale (305) 484-3888 Fort Myers (813) 656-3605 Jacksonville (904) 396-9659 Miami (305) 592-4106 Orlando (305) 894-7771 Tallahassee (904) 386-8926 Tampa (813) 287-2356 West Palm Beach (305) 683-5199	<b>Iowa</b> Bettendorf (319) 359-1357 Des Moines (515) 280-1614	<b>Missouri</b> St. Louis (314) 567-3900	<b>Ohio</b> Cincinnati (513) 793-3880 Cleveland (216) 642-0701 Columbus (614) 766-2204 Dayton (513) 298-2289 Toledo (419) 893-7197	<b>Tennessee</b> Chattanooga (615) 267-7412 Johnson City (615) 282-2718 Knoxville (615) 690-5172 Memphis (901) 761-2123 Nashville (615) 367-9403
<b>Arizona</b> Phoenix (602) 944-7900	<b>Georgia</b> Atlanta (404) 458-4353 Macon (912) 743-8994 Savannah (912) 897-5049	<b>Kansas</b> Kansas City (913) 491-3114 Wichita (316) 942-1409	<b>Montana</b> Big Fork (406) 837-5092	<b>Nebraska</b> Omaha (402) 397-1940	<b>Texas</b> Austin (512) 443-7822 Dallas (214) 247-0606 Fort Worth (817) 735-1947 Houston (713) 681-5001 Lubbock (806) 793-2377 McAllen (512) 687-2072 San Antonio (512) 824-7421
<b>Arkansas</b> Little Rock (501) 661-9008	<b>Hawaii</b> Honolulu (808) 533-7135	<b>Kentucky</b> Louisville (502) 426-4647	<b>Nevada</b> Las Vegas (702) 739-7900	<b>Oklahoma</b> Broken Arrow (918) 258-6333 Oklahoma City (405) 943-9156 Tulsa (918) 665-1806	<b>Utah</b> Salt Lake City (801) 272-2090
<b>California</b> Fresno (209) 264-5018 Hayward (415) 786-9240 Los Angeles (714) 979-6600 Oakland (415) 835-0900 Sacramento (916) 631-9433 San Diego (619) 569-8015 San Francisco (415) 345-8400 Stockton (209) 478-9596	<b>Illinois</b> Chicago (312) 519-4370 (312) 330-4320 Decatur (217) 875-5330 Peoria (309) 688-8729	<b>Louisiana</b> Baton Rouge (504) 293-6874 Lafayette (318) 988-3719 New Orleans (504) 885-3622 Shreveport (318) 424-0720	<b>New Hampshire</b> Manchester (603) 623-6264	<b>New Jersey</b> Iselin (201) 321-8780 Union (201) 687-7672	<b>Virginia</b> Richmond (804) 288-8311 Roanoke (703) 982-2776 Virginia Beach (804) 486-0174
<b>Colorado</b> Colorado Springs (719) 260-0297 Denver (303) 694-377 Ft. Collins (303) 223-2712	<b>Indiana</b> Evansville (812) 422-9176 Fort Wayne (219) 483-6999 Indianapolis (317) 788-5500 South Bend (219) 277-7040	<b>Maine</b> Portland (207) 854-0021	<b>New Mexico</b> Albuquerque (505) 881-1611	<b>New York</b> Albany (518) 482-0790 Amherst (716) 834-3815 Roslyn (516) 484-3490 Syracuse (315) 453-3780	<b>Washington</b> Seattle (206) 828-6600 Spokane (509) 325-2582
<b>Connecticut</b> Tolland (203) 875-7372 Wallingford (203) 265-5003	<b>Massachusetts</b> Boston (508) 658-0142 Springfield (413) 562-7994 Worcester (617) 792-4566	<b>Maryland</b> Landover (301) 459-2044	<b>North Carolina</b> Charlotte (704) 536-1201 Greensboro (919) 852-1758 Raleigh (919) 782-3365	<b>Pennsylvania</b> Erie (814) 456-5998 Philadelphia (215) 825-5300 Pittsburgh (412) 257-1040 York (717) 854-9776	<b>Wisconsin</b> Milwaukee (414) 774-9500
		<b>Michigan</b> Detroit (313) 597-7400 Grand Rapids (616) 247-7611	<b>Minnesota</b> Minneapolis (612) 829-1200	<b>Rhode Island</b> Providence (401) 943-6990	
		<b>Mississippi</b> Jackson (601) 936-9360	<b>North Dakota</b> Bismarck (701) 285-9555 Fargo (701) 293-7709	<b>South Carolina</b> Columbia (803) 254-7095 Greenville (803) 288-3490	

### Your Distributor Is:

International—TLX: 822024SEAIBU UF  
—FAX: (404) 751-2496

Siemens control products are available worldwide; the United States, Canada, and in over 128 countries around the world.