

**TOSHIBA**

---

# **G7 Adjustable Speed Drive Quick Start Guide**

**Document Number: 51671-001**

**Date: January, 2003**

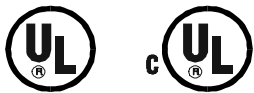

www.ElectricalPartManuals.com

# About This Guide

This guide was written by the TOSHIBA Technical Publications Group. This group is tasked with providing technical documentation for the **G7 Adjustable Speed Drive**. Every effort has been made to provide accurate and concise information to you, our customer.

TOSHIBA is a registered trademark of the TOSHIBA Corporation.

All other product or trade references appearing in this guide are registered trademarks of their respective owners.

The information in this guide is subject to change without notice.

**TOSHIBA International Corporation (TIC) shall not be liable for technical or editorial omissions or mistakes in this guide, nor shall it be liable for incidental or consequential damages resulting from the use of information contained in this guide.**

This guide is copyrighted. No part of this guide may be photocopied or reproduced in any form without the prior written consent of TOSHIBA International Corporation.

Email your comments, questions, or concerns about this publication to [Jay.Williams@TIC.TOSHIBA.COM](mailto:Jay.Williams@TIC.TOSHIBA.COM).

## Contacting TOSHIBA's Customer Support Center

TOSHIBA's Customer Support Center can be contacted to obtain help in resolving any **G7 Adjustable Speed Drive** system problem that you may experience or to provide application information.

The center is open from 8 a.m. to 5 p.m. (CST), Monday through Friday. The Support Center's toll free number is US (800) 231-1412/Fax (713) 466-8773 — Canada (800) 527-1204.

You may also contact TOSHIBA by writing to:

TOSHIBA International Corporation  
13131 West Little York Road  
Houston, Texas 77041-9990  
Attn: ASD Product Manager.

For further information on TOSHIBA's products and services, please visit our website at [TIC.TOSHIBA.COM](http://TIC.TOSHIBA.COM).

© Copyright 2002 TOSHIBA International Corporation.

All rights reserved.

Printed in the U.S.A.

# Introduction

Congratulations on the purchase of the new **G7 Adjustable Speed Drive (ASD)**. The **G7 True Torque Control<sup>2</sup> Adjustable Speed Drive** is a solid-state AC drive that features **True Torque Control<sup>2</sup>**. TOSHIBA's **Vector Control Algorithm** enables the motor to develop high starting torque and provide compensation for motor slip, which results in smooth, quick starts and highly efficient operation. The **G7 ASD** uses digitally-controlled pulse width modulation. The programmable functions may be accessed via the easy-to-use menu or via the **Direct Access Numbers** (see the section titled Program Mode on pg. 20). This feature, combined with TOSHIBA's high-performance software, delivers unparalleled motor control and reliability.

The **G7 ASD** is a very powerful tool, yet surprisingly simple to operate. The **G7 ASD** has an easy-to-read 240 x 64 pixel graphical LCD screen with a user-friendly **Electronic Operator Interface (EOI)**. The **EOI** provides easy access to the many monitoring and programming features of the **G7 ASD**.

The motor control software is menu-driven, which allows for easy access to the motor control parameters and quick changes when required.

To maximize the abilities of your new **G7 ASD**, a working familiarity with this guide will be required. This guide has been prepared for the **G7 ASD** installer. For a more in-depth description of the **G7 ASD** and its many functions, see the *G7 Adjustable Speed Drive Operation Manual (P/N 51546)*.

## This Guide's Purpose and Scope

This guide provides information that will assist the qualified installer in the safe installation of the **G7 Adjustable Speed Drive**. The *G7 Adjustable Speed Drive Operation Manual (P/N 51546)* should be consulted for more in-depth operational information and is available on a CD or a hardcopy. Either may be ordered from your TOSHIBA sales representative.

This installation guide provides information on the various features that pertain to the installation of this powerful cost-saving device and is applicable to the **G7 Adjustable Speed Drive** only.

## Important Notice

This guide may not cover all of the variations of ASD applications, nor may it provide information on every possible contingency concerning installation.

The contents of this guide shall not become a part of or modify any prior agreement, commitment, or relationship between the customer and TOSHIBA International Corporation. The sales contract contains the entire obligation of TOSHIBA International Corporation. The warranty contained in the contract between the parties is the sole warranty of TOSHIBA International Corporation's ASD Division and any statements contained herein do not create new warranties or modify the existing warranty.

Any electrical or mechanical modifications to this equipment without prior written consent of TOSHIBA International Corporation will void all warranties and may void the UL/CUL listing or other safety certifications. Unauthorized modifications may also result in equipment damage or personal injury.

# Table of Contents

<b>Safety Precautions</b> .....	<b>1</b>
Installation Precautions .....	1
Maintenance Precautions .....	2
Adjustable Speed Drive Inspection .....	3
Storage .....	3
Disposal .....	3
<b>Installation and Connections</b> .....	<b>4</b>
Installation Notes .....	4
Mounting the ASD .....	5
Connecting the ASD .....	6
I/O and Control .....	8
Typical Connection Diagram .....	9
<b>Electronic Operator Interface</b> .....	<b>10</b>
EOI Features .....	10
EOI Operation .....	11
<b>System Operation</b> .....	<b>12</b>
Initial Setup .....	12
Operation .....	12
Default Setting Changes .....	13
<b>Startup Wizard Requirements</b> .....	<b>14</b>
<b>System Configuration and Menu Options</b> .....	<b>17</b>
Root Menu .....	17
<b>Appendix A</b> .....	<b>33</b>
Enclosure Dimensions and Conduit Plate Information .....	33
<b>Appendix B</b> .....	<b>42</b>
EOI Remote Mounting .....	42
<b>Appendix C</b> .....	<b>45</b>
Current/Voltage Specifications .....	45
<b>Appendix D</b> .....	<b>47</b>
Dynamic Braking Resistor Installation Guidelines .....	47
Cable/Terminal Specifications .....	47

# Safety Precautions

DANGER!



Rotating shafts and electrical equipment can be hazardous. Installation, operation, and maintenance shall be performed by **Qualified Personnel** only.

**Qualified Personnel** shall be:

- Familiar with the construction and function of the ASD, the equipment being driven, and the hazards involved.
- Trained and authorized to safely clear faults, ground and tag circuits, energize and de-energize circuits in accordance with established safety practices.
- Trained in the proper care and use of protective equipment in accordance with established safety practices.

Installation of ASD systems should conform to the **2002 National Electrical Code Article 110 (NEC) (Requirements For Electrical Installations)**, all regulations of the **Occupational Safety and Health Administration**, and any other applicable national, regional, or industry codes and standards.

- Ensure that the **Run** functions (**F, R, Preset Speed**, etc.) of the ASD are off before performing a **Reset**. The post-reset settings may allow the ASD to start unexpectedly.
- In the event of a power failure, the motor may restart after power is restored.
- **Retry** or **Reset** settings may allow the motor to start unexpectedly. Warnings to this effect should be clearly posted near the ASD and motor.

**DO NOT** install, operate, perform maintenance, or dispose of this equipment until you have read and understood all of the following product warnings and user directions. Failure to do so may result in equipment damage, operator injury, or loss of life.

## Installation Precautions

DANGER!

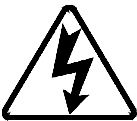

- Use lockout/tagout procedures on the branch circuit disconnect before installing the ASD.
- **Do Not** mount the device in a location that would produce catastrophic results if it were to fall from its mounting location (equipment damage or injury).
- Select a mounting location that is easily accessible by the user.
- Avoid installation in areas where vibration, heat, humidity, dust, metal particles, or high levels of electrical noise (EMI) are present.
- Do not install the ASD where it may be exposed to flammable chemicals or gasses, water, solvents, or other fluids.
- Always ground the unit to prevent electrical shock to personnel and to help reduce electrical noise. The input, output, and control power cables are to be run separately and each shall have its own ground cable.

*Note: Conduit is not an acceptable ground.*

- Ensure that the 3 phase input power is **Not** connected to the output of the ASD. This will destroy the ASD and may cause injury to personnel.
- **Do Not** connect resistors across terminals PA – PC or PO – PC. This may cause a fire.
- Do not install the ASD if it is damaged or if it is missing any component(s).
- Turn the power on only after attaching the front cover.

It is the responsibility of the person installing the ASD or the electrical maintenance personnel to setup the **Emergency Off** braking system of the ASD. The function of the **Emergency Off** braking function is to remove output power from the drive in the event of an emergency. A supplemental braking system may also be engaged in the event of an emergency. For further information on braking systems, see the *G7 Adjustable Speed Drive Operation Manual* (P/N 51546).

**Note:** A supplemental emergency stopping system should be used with the ASD. Emergency stopping should not be a task of the ASD alone.

It is the responsibility of the person installing the ASD or the electrical maintenance personnel to provide proper grounding and branch circuit protection in accordance with the 2002 NEC and applicable local codes.

Adequate working space and illumination must be provided for adjustment, inspection, and maintenance of the ASD (see **2002 NEC Article 110-16**).

A noncombustible insulating floor or mat should be provided in the area immediately surrounding the electrical system.

Follow all warnings and precautions and do not exceed equipment ratings.

See the section titled Installation and Connections on pg. 4 for additional information on installing the drive.

## Maintenance Precautions

**DANGER!**



- Use lockout/tagout procedures on the branch circuit disconnect before servicing the ASD.
- The ASD maintains a residual charge for a while after turning off the ASD. Wait at least five minutes before servicing the ASD after turning off the ASD power. Ensure that the **Charge LED** is off.
- **Do Not** attempt to disassemble, modify, or repair the ASD. Call your Toshiba sales representative for repair information.
- Do not place any objects inside of the ASD.
- Turn the power on only after attaching the front cover and **Do Not** remove the front cover of the ASD when the power is on.
- If the ASD should emit smoke or an unusual odor or sound, turn the power off immediately.
- The heat sink and the discharge resistors may become extremely hot to the touch. Allow the unit to cool before coming in contact or performing service on these items.
- Remove power from the ASD during extended periods of non-use.
- The system should be inspected periodically for damaged or improperly functioning parts, cleanliness, and to ensure that the connectors are tightened securely.

## Service Life Information

Part Name	Service Life	Remarks
Large Capacity Electrolytic Capacitor	5 Years	When not used for long periods, charge semi-annually.
Cooling Fan	26,000 Hours	
CN Connectors	100 Connects/Disconnects	
On-board Relays	500,000 Actuations	

# Adjustable Speed Drive Inspection

Upon receipt, perform the following checks:

- Inspect the unit for shipping damage.
- Check for loose, broken, or damaged parts.
- Ensure that the rated capacity and the model number specified on the nameplate conform to the order specifications.

Report any discrepancies to your TOSHIBA sales representative.

## Storage

Store the device in a well ventilated location (in its shipping carton is recommended).

Avoid storage locations of extreme temperatures, high humidity, dust, or metal particles.

## Disposal

Contact the local or state environmental agency in your area for details on the disposal of electrical components and packaging. Do not dispose of the unit via incineration.

# Installation and Connections

The **G7 True Torque Control<sup>2</sup> Adjustable Speed Drive** may be set up initially by performing a few simple configuration settings. To operate properly, the ASD must be securely mounted and connected to a power source (3-phase AC input at the **L1/R**, **L2/S**, and **L3/T** terminals). The control terminals of the ASD may be used by connecting the terminals of the **Control Terminal Strip** to the proper sensors or signal input sources (see the section titled I/O and Control on pg. 8).

**Note:** *The optional ASD-Multicom boards may be used to expand the functionality of the ASD. See the G7 ASD Operation Manual (P/N 51546) or contact your TOSHIBA sales representative for additional information on the available G7 ASD options.*

The output terminals of the ASD (**T1/U**, **T2/V**, and **T3/W**) must be connected to the motor that is to be controlled (see Figure 4 on pg. 9).

Upon initial system powerup, the **Startup Wizard** starts automatically. The **Startup Wizard** assists the user with the initial configuration of the **G7 True Torque Control<sup>2</sup> Adjustable Speed Drive**. See the section titled Initial Setup on pg. 12 for additional information on the **Startup Wizard**.

As a minimum, the installation of the ASD shall conform to **Article 110** of the **2002 NEC**, the **Occupational Safety and Health Administration** requirements, and to any other local and regional industry codes and standards.

## Installation Notes

When a brake-equipped motor is connected to the ASD, it is possible that the brake may not release at startup because of insufficient voltage. To avoid this, **Do Not** connect the brake or the brake contactor to the output of the ASD.

If an output contactor is used for bypass operation, it must be interlocked such that commercial power is never applied to the output terminals of the ASD (**T1/U**, **T2/V**, or **T3/W**).

If a secondary magnetic contactor (MC) is used between the output of the ASD and the motor, it should be interlocked such that the **ST – CC** terminals are disconnected before the output contactor is opened.

**Do Not** open and then close a secondary magnetic contactor between the ASD and the motor unless the ASD is off and the motor is not rotating.

**Note:** *Re-application of power via a secondary contact while the ASD is on or while the motor is still turning may cause ASD damage.*

On some devices the **ST-to-CC** connection is further enhanced by the operation of the **MS1 AUX** relay circuit. The **MS1 AUX** relay circuit is normally open and closes the **ST-to-CC** connection only after normal system power is available. The **MS1 AUX** relay circuit prohibits the **ST-to-CC** connection in the event that the **MS1** contactor fails to close during start up or if **MS1** opens while the ASD is running. For the 200 volt ASD this feature is available on the 30 HP system, on the 460 volt ASD this feature is available on the 50 HP and above systems, and on the 600 volt ASD it is available on the 60 HP and above systems.

Figure 1. MS1 AUX Circuit Configuration.

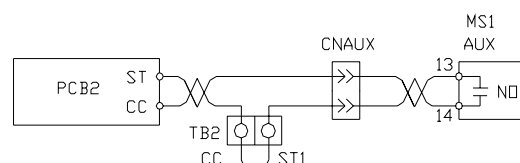

The ASD input voltage should remain within 10% of the specified input voltage range. Input voltages approaching the upper or lower limit settings may require that the overvoltage and undervoltage stall protection level parameters, **F626** and **F629**, be adjusted. Voltages outside of the permissible tolerance should be avoided.

The input power frequency should be  $\pm 2$  Hz of the specified input frequency.

Do not use an ASD with a motor that has a power rating that is higher than the rated output of the ASD.

The ASD is designed to operate NEMA B motors. Consult with your sales representative before using the ASD for special applications such as with an explosion-proof motor or applications with a piston load.

**Do Not** apply commercial power to the output terminals **T1/U**, **T2/V**, or **T3/W**.

Disconnect the ASD from the motor before megging or applying a bypass voltage to the motor.

Interface problems may occur when this ASD is used in conjunction with some types of process controllers. Signal isolation may be required to prevent controller and/or ASD malfunction (contact your TOSHIBA sales representative or the process controller manufacturer for additional information about compatibility and signal isolation).

Use caution when setting the output frequency. Over speeding a motor decreases its ability to deliver torque and may result in damage to the motor and/or the driven equipment.

All G7 ASDs are equipped with internal DC bus fuses. However, not all G7 ASDs are equipped with internal primary power input fuses (HP dependent). When connecting two or more drives that have no internal fuse to the same power line as shown in Figure 2, it will be necessary to select a circuit-breaking configuration that will ensure that if a short circuit occurs in ASD 1, only MCCB2 trips, not MCCB1. If it is not feasible to use this configuration, insert a fuse between MCCB2 and ASD 1.

Figure 2. Circuit breaker configuration.

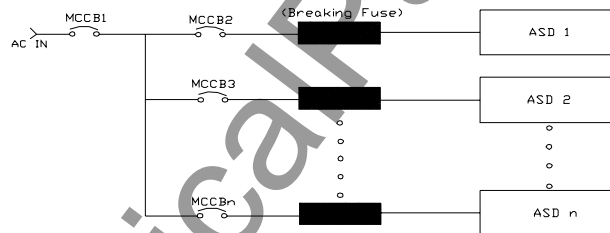

## Mounting the ASD

### Caution!



Install the unit securely in a well ventilated area that is out of direct sunlight using the four mounting holes on the rear of the ASD.

The ambient temperature rating for the G7 is from 14 to 104° F (-10 to 40° C). The process of converting AC to DC, and then back to AC produces heat. During normal ASD operation, up to 5% of the input energy to the ASD may be dissipated as heat. If installing the ASD in a cabinet, ensure that there is adequate ventilation.

**Do Not** operate the ASD with the enclosure door open.

When installing multiple ASDs, ensure that there is a clearance space of at least 8 inches (20 cm) from the top and the bottom of adjacent units. There should be at least 2 inches (5 cm) on either side of adjacent units. For the models below 50 HP the top and bottom clearance specifications may be reduced to 4 inches (10 cm). This space ensures that adequate ventilation is provided (see the section titled Enclosure Dimensions/Weight on pg. 33 for additional information on mounting space requirements).

**Note:** Ensure that the ventilation openings are not obstructed.

ASDs produce high-frequency noise — steps must be taken during installation to avoid the negative effects of noise. Listed below are some examples of measures that will help to combat noise problems.

- Separate the input and output power conductors of the main circuit. Do not install the input and output wires in the same duct or in parallel with each other, and do not bind them together.
- Do not install the input or output power conductors of the main circuit and the wires of the control circuit in the same duct or in parallel with each other, and do not bind them together.
- Use shielded wires or twisted wires for the control circuits.
- Ensure that the grounding terminals (G/E) of the ASD are securely connected to ground.
- Connect a surge suppressor to every electromagnetic contactor and every relay installed near the ASD.
- Install noise filters as required.

## Connecting the ASD

**DANGER!**



Refer to the section titled Installation Precautions on pg. 1 and the section titled Lead Length Specifications on pg. 7 before attempting to connect the ASD and the motor to electrical power.

### System Grounding

Proper grounding helps to prevent electrical shock and to reduce electrical noise. The ASD is designed to be grounded in accordance with **Article 250** of the **2002 NEC** or **Section 10/Part One** of the **Canadian Electrical Code (CEC)**.

The grounding conductor shall be sized in accordance with **Article 250-122** of the **NEC** or **Part One-Table 6** of the **CEC**.

*Note:* The metal of conduit is not an acceptable ground.

The input, output, and control lines of the system shall be run in separate metal conduits and each shall have its own ground conductor.

### Power Connections

**DANGER!**



**L1/R, L2/S, and L3/T** are the 3-phase input supply terminals for the ASD. The ASD may be operated from a single-phase supply. When operating using a single-phase supply, use the L1 and L3 terminals.

**T1/U, T2/V, and T3/W** are the output terminals of the ASD that connect to the motor.

An inductor may be connected across terminals **PA** and **PO** to provide additional filtering. When not used, a jumper is connected across these terminals (see Figure 4 on pg. 9).

Connect the input and output power lines of the ASD as shown in Figure 3.

*Note:* In the event that the motor rotates in the wrong direction when powered up, reverse any two of the three ASD output power leads connected to the motor.

Figure 3. ASD/Motor connection diagram.

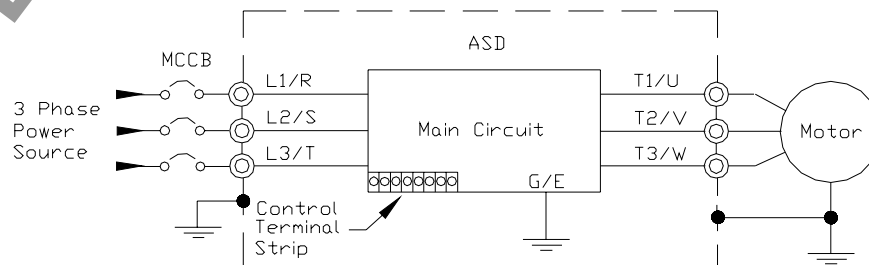

Connect the 3-phase input power to the input terminals of the ASD at **L1/R**, **L2/S**, and **L3/T**. Connect the output of the ASD to the motor from terminals **T1/U**, **T2/V**, and **T3/W**. The input and output conductors and terminal lugs used shall be in accordance with the requirements listed in Appendix D on pg. 47.

If conductors smaller than the recommended sizes are used in parallel for the input or output power, each branch of the parallel set shall have its own conduit and not share its conduit with other parallel sets (i.e., place **U1**, **V1**, and **W1** in one conduit and **U2**, **V2**, and **W2** in another).

**Note:** *National and local codes should be referenced when running more than three conductors in the same conduit.*

Install a molded case circuit breaker (MCCB) or fuse between the 3-phase power source and the ASD in accordance with the **2002 NEC Article 430-102** through **430-111** and the fault current setting of the ASD.

For 600 volt ASDs, the 15 HP or less drives (P/N VT130G7U6015 – 6160) require a class-J fuse rated at 600 Volts/30 A.

## Lead Length Specifications

Adhere to the NEC and any local codes during the installation of ASD/Motor systems. Excessive lead lengths may adversely effect the performance of the motor. Special cables are not required. Lead lengths from the ASD to the motor in excess of those listed in Table 1 may require filters to be added to the output of the ASD. Table 1 lists the suggested maximum lead lengths for the listed motor types.

Table 1.

Model	PWM Carrier Frequency	Suggested Maximum Lead Distance
230 Volt	All	1000 feet
460 Volt	≤ 5 kHz	600 feet
	> 5 kHz	300 feet
600 Volt	≤ 5 kHz	200 feet
	> 5 kHz	100 feet

*Contact TOSHIBA for application assistance when using lead lengths in excess of those listed.*

*Exceeding the peak voltage rating or the allowable thermal rise time of the motor insulation will reduce the life expectancy of the motor.*

*For proper operation, the carrier frequency must be 2.2 kHz or above except when operating in the **Constant Torque**, **Variable Torque**, or the **5-Point Setting** modes.*

## Startup and Test

Perform the following checks before turning on the unit:

- **L1/R**, **L2/S**, and **L3/T** are connected to the 3-phase input power.
- **T1/U**, **T2/V**, and **T3/W** are connected to the motor.
- The 3-phase input voltage is within the ASD setup tolerances.
- There are no shorts and all grounds are secured.

# I/O and Control

The ASD can be controlled by several input types and combinations thereof, as well as operate within a wide range of voltage levels. This section discusses the ASD control methods and supported I/O functions.

The **Control Terminal Strip** supports discrete and analog I/O functions. Table 2 lists the names, the default settings, and the descriptions of the input and output terminals of the **Control Terminal Strip** PWA.

Figure 4 on pg. 9 shows the basic connection diagram for the G7 system.

**Table 2. Control Terminal Strip** default assignment terminal names and functions.

Default Term. Setting	Input/Output	Default Function
ST	Discrete Input	<b>Standby</b> (jumper to <b>CC</b> to operate the unit) — Multifunctional programmable discrete input.
RES	Discrete Input	<b>Reset</b> — Multifunctional programmable discrete input.
F	Discrete Input	<b>Forward</b> — Multifunctional programmable discrete input.
R	Discrete Input	<b>Reverse</b> — Multifunctional programmable discrete input.
S1	Discrete Input	<b>Preset Speed 1</b> — Multifunctional programmable discrete input.
S2	Discrete Input	<b>Preset Speed 2</b> — Multifunctional programmable discrete input.
S3	Discrete Input	<b>Preset Speed 3</b> — Multifunctional programmable discrete input.
S4	Discrete Input	<b>Emergency Off</b> — Multifunctional programmable discrete input.
RR	Analog Input	<b>RR</b> — Multifunction programmable analog input (0.0 to 10 volt input — 0 to 80 Hz output).
RX	Analog Input	<b>RX</b> — Multifunctional programmable analog input (-10 to +10 VDC input — -80 to +80 Hz output).
II	Analog Input	<b>II</b> — Multifunctional programmable analog input (4 [0] to 20 mADC input — 0 to 80 Hz output).
VI	Analog Input	<b>VI</b> — Multifunctional programmable analog input (0 to 10 VDC input — 0 to 80 Hz output).
P24	DC Output	24 VDC @ 50 mA output.
PP	DC Output	<b>PP</b> — 10.0 VDC voltage source for the external potentiometer.
OUT1	Discrete Output	<b>Low Frequency</b> — Multifunctional programmable discrete output.
OUT2	Discrete Output	<b>Reach Frequency</b> — Multifunctional programmable discrete output.
FP	Output	<b>Frequency Pulse</b> — an output pulse train that has a frequency which is based on the output frequency of the ASD.
AM	Output	Produces an output current that is proportional to the magnitude of the function assigned to either of these terminals (see Output Terminal Functions on pg. 22).
FM	Output	
FLC	Output	Fault relay (common).
FLB	Output	Fault relay (N.C.).
FLA	Output	Fault relay (N.O.).
CC	—	Control common ( <b>Do Not</b> connect to <b>Earth Gnd</b> ).
<b>Discrete Input Terminals</b> ⇒ <b>On</b> = connected to <b>CC</b> .		

# Typical Connection Diagram

Figure 4. G7 connection diagram.

**Note:** When connecting multiple wires to the PA, PB, PC, or PO terminals, do not connect a solid wire and a stranded wire to the same terminal.

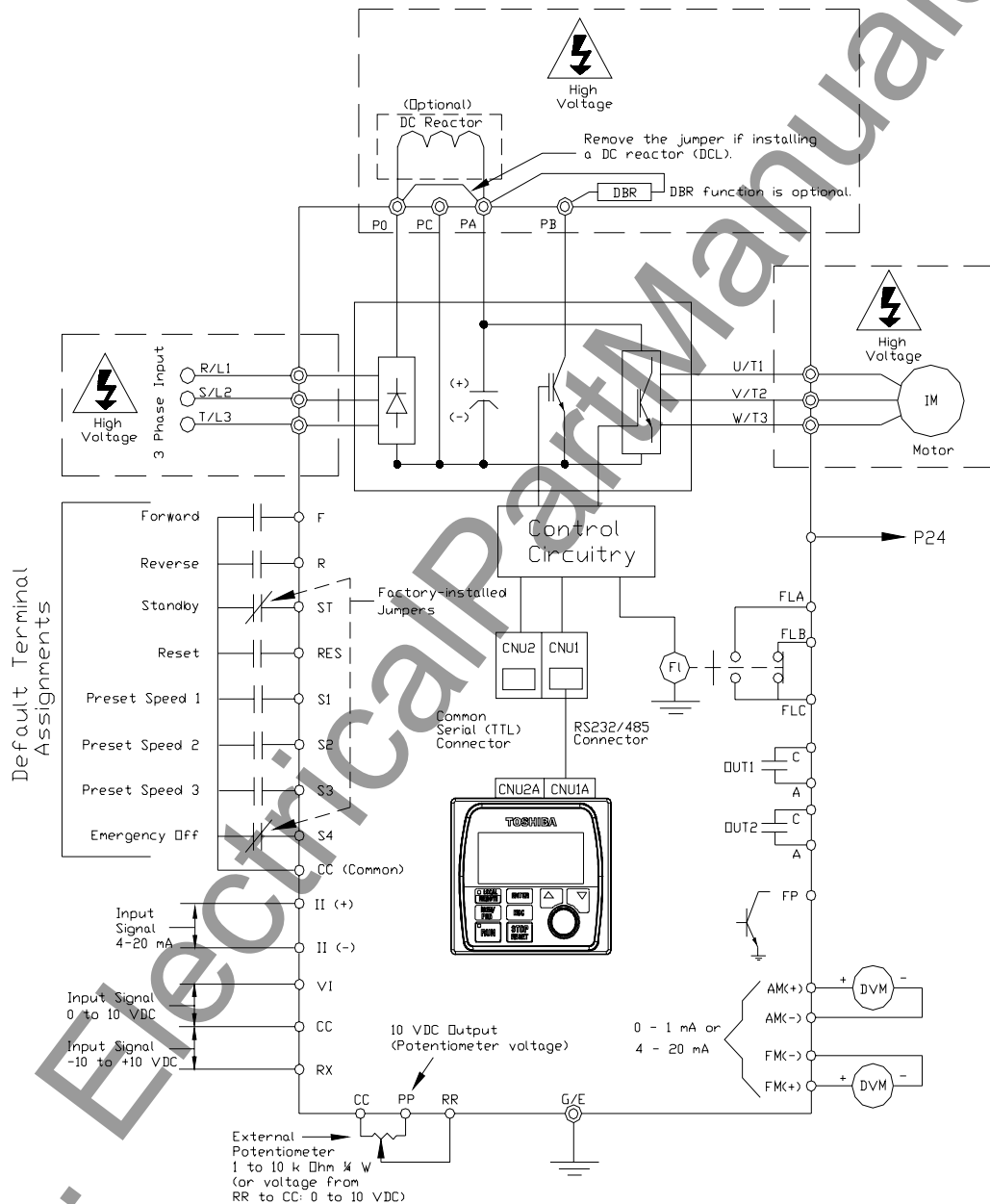

# Electronic Operator Interface

The G7 **Electronic Operator Interface** (EOI) is comprised of an LCD display, two LEDs, a rotary encoder, and eight keys. These items are described below and their locations are provided in Figure 5 on pg. 11.

The **EOI** can be mounted remotely from the ASD as described in Appendix B on pg. 42. The mounting dimensional requirements may also be found in Appendix B. Using a screw length that exceeds the specified dimensions may cause deformation of the outer surface of the bezel as shown in Figure 18 on pg. 44.

The interface can operate up to distances of 15 feet from the ASD via the Common Serial (TTL) Port. For distances beyond 15 feet, the RS-485 port is recommended.

## EOI Features

**LCD Display** — Displays configuration information, performance data (e.g., motor frequency, bus voltage, torque, etc.), and diagnostic information.

**Local|Remote Key** — Toggles the system to and from the **Local** and **Remote** modes. The LED is on when the system is in the **Local Command** mode. The **Local** mode allows the **Command** and **Frequency** control functions to be carried out via the **EOI**.

The **Remote** mode enables the **Command** and **Frequency** control functions to be carried out via the **Control Terminal Strip, LED Keypad, RS232/485, Communication Card, or Pulse Input**. The selection may be made via Program ⇒ Fundamental Parameters ⇒ Standard Mode Settings ⇒ **Command Mode**.

*Note:* The **LED Keypad** is under development and is unavailable at the time of the release of this manual.

The availability of the **Local** mode of operation (**Command** and **Frequency** control) may be disabled via Program ⇒ EOI Option Setups ⇒ **Local/Remote Key**. The availability of the **Local** mode of operation may be reinstated by changing this setting or performing a **Type Reset (Restore Factory Default)**.

**Enter Key** — Selects a menu item to be changed or accepts and records the changed data of the selected field (same as pressing the **Rotary Encoder**).

**Esc Key** — Returns to the previous level of the menu tree, toggles between the **Panel** and the **Frequency Command** screens, or cancels changes made to a field if pressed while still in the reverse video mode (dark background/light text).

**Run Key** — Issues the **Run** command while in the **Local** mode.

**Run Key Status LED** — Illuminates green while stopped or red while running.

**Stop Key** — Issues the **Off** command (decelerates to **Stop** at the programmed rate) if pressed once while in the **Local** mode or initiates an **Emergency Off** (terminates the ASD output and applies the brake if so configured) if pressed twice quickly from the **Local** or **Remote** mode.

**Up Key** — Increases the value of the selected parameter or scrolls up the menu listing (continues during press and hold).

**Down Key** — Decreases the value of the selected parameter or scrolls down the menu listing (continues during press and hold).

**Rotary Encoder** — Functions as the **Up** key, the **Down** key, and the **Enter** key. Turn the **Rotary Encoder** either clockwise or counterclockwise to perform the **Up** or **Down** key functions. Press the **Rotary Encoder** to perform the **Enter** function. Simultaneously pressing and turning the **Rotary Encoder** performs a user-defined function (see Program ⇒ EOI Option Setup ⇒ Preferences ⇒ **Pressed Encoder Action**).

**MON/PRG** — Provides a means to access the three root menus. Pressing the **MON/PRG** key repeatedly loops the system through the three root menus (see Figure 8 on pg. 17). While looping through the root menus, the **Program** menu will display the last menu screen or sub-menu item being accessed at the time that the **MON/PRG** key was pressed.

Figure 5. The G7 Electronic Operator Interface.

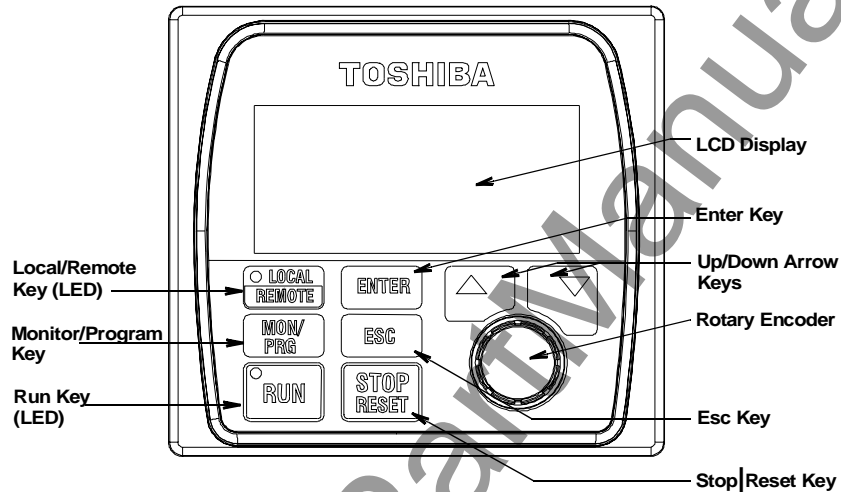

## EOI Operation

The **EOI** is the primary input/output device for the user. The **EOI** may be used to monitor system functions, input data into the system, or perform diagnostics.

*Note: The Up/Down arrow keys and the Enter key may be used to perform the functions of the Rotary Encoder. The Rotary Encoder will be used in this explanation and throughout this manual for the Up, Down, and Enter key functions.*

The software used with the G7 is menu driven; thus, making it a select and click environment. The operating parameters of a motor may be selected and viewed or changed using the **EOI**.

To change a parameter setting, go to the **Program** mode by pressing the **MON/PRG** key until the **Program** menu is displayed. Turn the **Rotary Encoder** until the desired parameter group is within the cursor block. Press the **Rotary Encoder** (repeat if there is a submenu).

The selection will take on the reverse video format (dark background/light text). Turn the **Rotary Encoder** to change the value of the parameter. Press the **Esc** key while the display is in the reverse video mode to exit the menu without saving the change or press the **Rotary Encoder** to accept the new setting.

Repeated **Esc** key entries takes the menu back one level each time the **Esc** key is pressed until the root level is reached. After reaching the root level, continued **Esc** entries will toggle the system to and from the **Frequency Command** mode and the **Panel** menu.

*Note: Panel menu changes entered here will affect EOI-controlled ASD operation only. LED Keypad-controlled functions will not be affected. LED Keypad-controlled operation settings may be viewed or changed at F008.*

# System Operation

## Initial Setup

Upon initial powerup of the ASD the **Startup Wizard** starts. The **Startup Wizard** assists the user with the initial configuration of the input power settings and the output parameters of the **G7** drive. The drive may also be setup by directly accessing each of the individual parameters.

The **Startup Wizard** queries the user for the following information:

1. **Run now?** (if selected continue on to step #2)/**Run next time at power up?** (if selected go to Program Mode)/**Manually configure?** (if selected go to Finish ⇒ Program Mode).
2. The **Voltage** and **Frequency** rating of the motor.
3. The **Upper Limit** frequency.
4. The **Lower Limit** frequency.
5. Adjust **Accel/Decel** times automatically? (if **Yes**, continue from step #8).
6. The **Acceleration** time.
7. The **Deceleration** Time.
8. The **Volts/Hertz** setting.
9. The motor **Current** rating.
10. The **Command** source.
11. The **Frequency Reference** source.

See the section titled Startup Wizard Requirements on pg. 14 for additional information on the **Startup Wizard**.

## Operation

To turn the motor on perform the following:

1. Press the **MON/PRG** key until the **Frequency Command** screen is displayed (see Figure 6).
2. Press the **Local|Remote** key to enter the **Local** mode (green **Local** LED illuminates).
3. Turn the **Rotary Encoder** clockwise until the **Frequency Command** value is at the desired setting.
4. Press the **Run** key and the motor runs at the **Frequency Command** value.

**Note:** *The speed of the motor may be changed while the motor is running by using the **Rotary Encoder** to change the **Frequency Command** value.*

5. Press the **Stop|Reset** key to stop the motor.

Figure 6. Frequency Command screen.

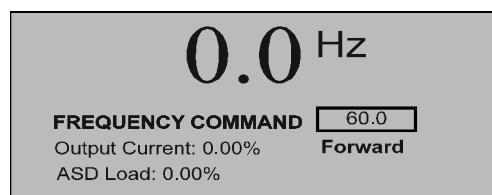

# Default Setting Changes

To change a default parameter setting, press **ESC** until the screen toggles to and from the **Frequency Command** screen and the **Panel Menu**. From the **Frequency Command** screen, go to the **Program** mode by pressing the **MON/PRG** key twice and the **Program** menu is displayed. Turn the **Rotary Encoder** until the desired parameter group is within the cursor block and press the **Rotary Encoder** (repeat if there is a submenu).

Press the **Rotary Encoder** to select the default setting to be changed and the selection takes on the reverse video format (dark background, light text). Turn the **Rotary Encoder** to change the value of the parameter. Press the **Rotary Encoder** to accept the new setting or press the **Esc** key before accepting the change to exit the menu without saving the change.

For a complete listing of the **Program** mode menu options, see the section titled Program Mode on pg. 20. Menu items are listed and mapped for convenience. The **Direct Access Numbers** are listed where applicable.

The default settings may also be changed by entering the **Parameter Number** of the setting to be changed at the **Direct Access** menu (Program ⇒ Direct Access ⇒ *Applicable Parameter Number*). A listing of the **Direct Access Numbers** and a parameter description of each may be found in the *G7 ASD Operation Manual* (P/N 51546).

A listing of all parameters that have been changed from the default setting may be viewed sequentially by accessing the **Changed From Default** screen (Program ⇒ **Changed From Default**).

*Note:* Parameter **F201** was changed to create the example shown in Figure 7.

The **Changed From Default** feature allows the user to view (or change) the parameters that are different from the default or the post-reset settings. Once the **Changed From Default** screen is displayed, the system automatically scrolls through all of the system parameters and halts once reaching a changed parameter.

The **Rotary Encoder** may be clicked once clockwise to continue scrolling forward or clicked once counterclockwise to begin scrolling in reverse. With each click of the **Rotary Encoder** from a stop, the system scrolls and stops at the next parameter that has been changed.

Pressing the **Rotary Encoder** while a changed parameter is displayed accesses the settings of the changed parameter for viewing or changing.

Pressing **Esc** while the system is performing a **Changed From Default** search terminates the search. Pressing **Esc** when done searching (or halted at a changed parameter) returns the system to the **Program Menu**.

Figure 7. Changed From Default screen.

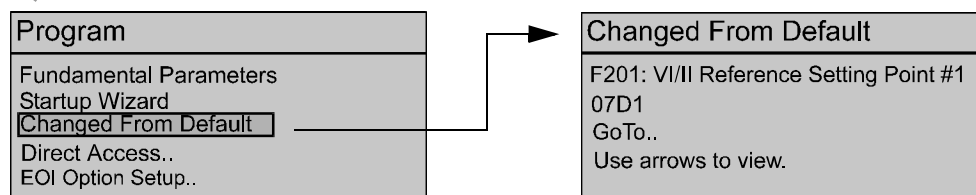

# Startup Wizard Requirements

The **Startup Wizard** queries the user for information on the input and output signal parameters of the ASD. The drive may also be setup by directly accessing each of the control settings via the **Direct Access Numbers** or the **Program** menu.

Upon initial system powerup, the **Startup Wizard** starts automatically. The user is queried to either (1) run the **Startup Wizard (Run Now)**, (2) perform a manual setting of user-selected parameters, or (3) run the **Startup Wizard** at the next power up.

If selection (3) is chosen, the system returns to the **Program** menu and defaults to the **Startup Wizard** on the next power up. If selection (2) is chosen, the system returns to the **Program** menu. If selection (1) (**Run Now**) is selected, the **Startup Wizard** will start and assist the user with the configuration of the ASD using the following user-input screens:

## Voltage and Frequency Rating of the Motor

Motors are designed and manufactured for a specific voltage and frequency range. The voltage and frequency specifications for a given motor may be found on the nameplate of the motor.

Wizard: Motor Rating
<input type="text" value="200V 50Hz"/>
<input type="text" value="200V/230V 60Hz"/>
<input type="button" value="I will configure manually. Finish."/>

## Upper Limit Frequency

This parameter sets the highest frequency that the ASD will accept as a frequency command or frequency setpoint. The ASD may output frequencies higher than the **Upper Limit Frequency** (but, lower than the **Maximum Frequency**) when operating in the **PID Control** mode, **Torque Control** mode, or the **Vector Control** modes (sensorless or feedback).

Wizard: Upper Limit Frequency
What is your upper limit frequency?
<input ]="" hz"="" type="text" value="60"/>
<input type="button" value="Next"/>
<input type="button" value="Finish"/>

## Lower Limit Frequency

This parameter sets the lowest frequency that the ASD will accept as a frequency command or frequency setpoint. The ASD will output frequencies lower than the **Lower Limit Frequency** when accelerating to the lower limit or decelerating to a stop. Frequencies below the **Lower Limit** may be output when operating in the **PID Control** mode, **Torque Control** mode, or the **Vector Control** modes (sensorless or feedback).

Wizard: Min. Frequency
What is your lower limit frequency?
<input type="text" value="0.00 Hz"/>
<input type="button" value="Next"/>
<input type="button" value="Finish"/>

## Adjust Accel/Decel Automatically?

When enabled, the ASD adjusts the acceleration and deceleration rates according to the applied load. The acceleration and deceleration times range from 12.5 to 800% of the programmed values for the active acceleration time [e.g., **Acceleration Time #1 (F009)** and **Deceleration Time #1 (F010)**].

The motor and the load must be connected prior to selecting **Automatic Accel/Decel**. If **Automatic Accel/Decel** is not enabled, the **Acceleration** screen will appear followed by the **Deceleration** screen.

Wizard: Accel/Decel
Do you want the drive to adjust accel/decel times automatically?
<input type="button" value="Yes"/>
<input type="button" value="No"/>
<input type="button" value="Finish"/>

## Volts Per Hertz Setting

This function establishes the relationship between the output frequency and the output voltage.

Settings:

- Constant Torque
- Variable Torque
- Automatic Torque Boost
- Sensorless Vector Control (Speed)
- Automatic Torque Boost + Automatic Energy Savings
- Sensorless Vector Control (Speed) + Automatic Energy Savings
- V/f 5-point Setting (Opens 5-point Setting Screen)
- Sensorless Vector Control (Speed/Torque Switching)
- PG Feedback Vector Control (Speed/Torque Switching)
- PG Feedback Vector Control (Speed/Position Switching)

Wizard: Volts/Hertz
What type of volts/hertz control do you want?
<input type="text" value="Constant Torque"/>
<input type="button" value="Next"/>
<input type="button" value="Finish"/>

## Motor Current Rating

This parameter allows the user to input the full-load amperage (FLA) of the motor. This value is used by the ASD to determine the **Thermal Overload** protection setting for the motor.

Wizard: Motor Current
What is the rated current of your motor?
<input type="text" value="5.00 A"/>
<input type="button" value="Next"/>
<input type="button" value="Finish"/>

## Command Source

This selection allows the user to establish the source of the **Run** commands (e.g., **F**, **R**, **Stop**, etc.).

Settings:

- Use Control Terminal Strip
- Use LED Keypad Option
- Use Common Serial (TTL)
- Use RS232/485
- Use Communication Card

Wizard: Command Source
Where will your run/stop and other commands come from?
<input type="text" value="Use terminal block"/>
<input type="button" value="Next"/>
<input type="button" value="Finish"/>

## Frequency Reference Source

This selection allows the user to establish the source of the **Frequency** (speed) command.

- Use VI/II
- Use RR
- Use RX
- Use Option Card RX2
- Use LED Keypad Option
- Use Binary/BCD Input
- Use Common Serial (TTL)
- Use RS232/485
- Use Communication Card
- Use Motorized Pot Simulation
- Use Pulse Input Option

Wizard: Frequency Source
Where will your frequency reference come from?
<input type="text" value="Use RR"/>
<input type="button" value="Next"/>

## Wizard: Finish

This screen is the final screen of the **Startup Wizard**. The basic parameters of the ASD have been set. Click **Finish** to return to the **Program** mode. Additional application-specific programming may be required.

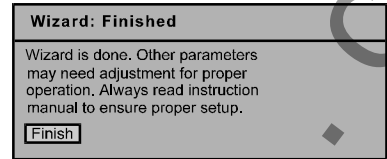

# System Configuration and Menu Options

## Root Menus

The **MON/PRG** key accesses the three primary modes of the G7: the **Frequency Command** mode, the **Monitor** mode, and the **Program** mode. From either mode, press the **MON/PRG** key to loop through to the other two modes (see Figure 8). While in the **Frequency Command** mode, pressing the **ESC** key toggles the menu to and from the **Panel** menu and the **Frequency Command** mode.

*Note: Panel menu changes made when accessing the Panel menu using the method shown in Figure 8 is effective for Local LCD EOI control Only.*

Figure 8. Root menu mapping.

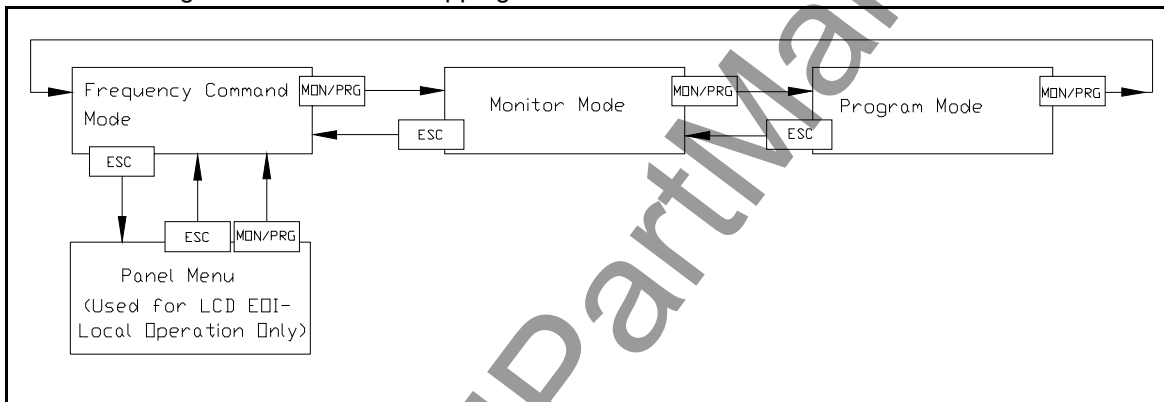

## Frequency Command Mode

### Frequency Setting

While operating in the **Local** mode (**Local** LED is illuminated on the front panel), the running frequency of the motor may be set from the **Frequency Command** screen. Using the **Rotary Encoder**, enter the **Frequency Command** value and then press the **Run** key. The motor will run at the **Frequency Command** speed and may be changed while running.

### Scrolling Monitor

The **Output Current** and the **ASD Overload** values are displayed below the **Frequency Command** parameter of the **Frequency Command** screen (default setting). Other user-selected parameters may be displayed on this screen for quick-access monitoring while running. These parameters may be accessed and enabled for display by placing a check in the box next to the item listed at Program ⇒ Monitor Setup ⇒ **Scrolling Monitor Select**.

The display time setting for each enabled item may be set from 1 to 60 seconds. This feature is useful when more than two items are enabled for display (scrolling display). The parameters that may be displayed on the **Scrolling Monitor** are listed in the section titled Monitor Mode on pg. 18.

## Panel Menu

The Panel menu may be accessed by pressing **ESC** from the **Frequency Command** screen.

The control settings of the **Panel** menu are effective for **LCD EOI** control only when accessed using this method. For further information on the **Panel** menu, see the *G7 ASD Operation Manual*.

The **Panel** menu provides quick access to the following parameters:

**Direction** — **Forward** or **Reverse**.

**Stop Pattern** — The **Decel Stop** or **Coast Stop** settings determines the method used to stop the motor when using the **Stop|Reset** key of the **EOI**.

*Note:* The **Stop Pattern** setting has no effect on the **Emergency Off** settings of **F603**.

**V/f Group** — 1 of 4 **V/f** profiles may be selected and run.

**Accel/Decel Group** — 1 of 4 **Accel/Decel** profiles may be selected and run.

**Feedback in Panel Mode** — This feature enables or disables the **PID** feedback function so long as the ASD is operating in the **Local** mode.

**Torque Limit Group** — This parameter is used to select 1 of 4 preset positive torque limits to apply to the active motor (of a multiple motor configuration).

## Monitor Mode

The **Monitor** mode allows the user to monitor motor performance variables, control settings, and configuration data during motor operation. There are 46 items that may be monitored from this mode. The items are listed and described below.

*Note:* The **Monitor** mode is a read-only mode. The settings **cannot** be changed from the **Monitor** mode. For information on how to change the values, see the section titled *Default Setting Changes* on pg. 13.

**Running Frequency** — Displays the G7 output frequency.

**Frequency Reference** — Displays the **Frequency** setpoint.

**Output Current** — Displays the **Output Current** as a percentage of the rated capacity of the G7.

**Bus Voltage** — Displays the **Bus Voltage** as a percentage of the rated capacity of the G7.

**Output Voltage** — Displays the **Output Voltage** as a percentage of the rated capacity of the G7.

**Input Signal Status** — Displays the status of the discrete input lines of the **Control Terminal Strip**.

**Out1 Out2 FL** — Displays the status of the output-relay terminals of the **Control Terminal Strip**.

**Timer** — Displays the cumulative run time in hours.

**Postcomp Frequency** — Displays the output frequency after the application of the slip compensation correction value.

**Feedback (inst.)** — Provides a status of the real time feedback in Hz.

**Feedback (1 second)** — Provides a status of the 1-second averaging feedback in Hz.

**Torque** — Displays the output torque as a percentage of the rated capacity of the G7.

**Torque Reference** — Displays the torque reference as a percentage.

**Torque Current** — Displays the current being used to produce torque.

**Excitation Current** — Displays the current required to produce the excitation field.

**PID Value** — Displays the **PID** feedback value in Hz (Proportional/Integral/Derivative).

**Motor Overload** — Displays the **Motor Overload** value as a percentage of the rated capacity of the motor.

**ASD Overload** — Displays the **ASD Overload** as a percentage of the rated capacity of the G7.

**DBR Overload** — Displays the **DBR Overload** value as a percentage of the **Dynamic Braking Resistor** capacity.

**Motor Load** — Displays the **Motor Load** in real time as a percentage of the rated capacity of the motor.

**ASD Load** — Displays the **ASD Load** as a percentage of the rated capacity of the G7.

**DBR Load** — Displays the **DBR Load** as a percentage of the **Dynamic Braking Resistor** capacity.

**Input Power** — Displays the **Input Power** in Kilowatts (Kw).

**Output Power** — Displays the **Output Power** in Kilowatts (Kw).

**Peak Current** — Displays the **Peak Current** since the last start was initiated. The current is displayed as a percentage of the rated capacity of the G7.

**Peak Voltage** — Displays the **Peak Voltage** since the last start was initiated. The voltage is displayed as a percentage of the rated capacity of the G7.

**PG Speed** — Displays the **PG Speed**.

**Direction** — Displays the **Direction** command (Forward/Reverse).

**PG Position** — Displays the **Pulse Generator Position**.

**RR** — Displays the **RR** input value as a percentage of the full range of the RR value (potentiometer input).

**VI/II** — Displays the **VI** input setting as a percentage of the full range of the **VI/II** value.

*Note: The VI/II input represents two analog inputs (and terminals). The VI input terminal is primarily used for a 0 – 10 VDC analog signal and the II input terminal is used for current loop applications, such as with a 4-20 mA signal. Either may be used as a frequency or torque command source; however, the two cannot function simultaneously. Throughout this manual they will be listed as VI/II.*

**RX** — Displays the **RX** input setting as a percentage of the full range of the **RX** value (-10 to +10 VDC input).

**RX2** — Displays the **RX2** input setting as a percentage of the full range of the **RX2** value.

*Note: The RX2 function is available only on the ASD-Multicom option board.*

**FM** — Displays the output frequency value as a percentage of the full range of the **FM** value.

**AM** — Displays the output current as a percentage of the full range of the **AM** value.

**Option Type** — Displays the type form number of the installed **ASD-Multicom** option board.

**Option Term A** — TBD.

**Option Term B** — TBD.

**Option Term O** — TBD.

**Option Term P** — TBD.

**Max. Output** — TBD.

◆ **Pattern Select** — Displays the selected pattern if using **Pattern Run**.

**Repeats Left** — Displays the number of patterns remaining if using **Pattern Run**.

**Pattern** — Displays the active **Pattern Run** ID number.

**Pattern Time Left** — Displays the time remaining in the current pattern if using **Pattern Run**.

**Fault Status** — Displays the current fault or **No Fault**.

# Program Mode

Table 3 lists the menu items of the **Program** mode and maps the flow of the menu selections. The **Parameter Numbers** for the listed functions are provided where applicable. The functions listed may be accessed (and changed) as mapped below or via the **Direct Access** method: Program ⇒ Direct Access ⇒ *Applicable Parameter Number*.

**Table 3. Program mode mapping.**

Program Menu Navigation				
Primary Menu	Sub Menu	Parameter Name	Parameter Number	
Fundamental Parameters	Frequency Setting	Maximum Frequency	F011	
		Upper Limit	F012	
		Lower Limit	F013	
		V/f Pattern	F015	
	Standard Mode Selection	Command Mode	F003	
		Frequency Mode #1	F004	
		Frequency Mode #2	F207	
		Reference Priority Selection	F200	
		Mode #1/#2 Switching Frequency	F208	
	Accel/Decel #1 Settings	Accel #1	F009	
		Decel #1	F010	
		Accel/Decel #1 Pattern	F502	
		Automatic Accel/Decel Selection	F000	
	Motor Set #1	#1 Base Frequency	F014	
		#1 Max Output Voltage	F306	
		#1 Torque Boost	F016	
Electronic Thermal Protection Level #1		F600		
Startup Wizard	(Used to perform the initial setup.)		N/A	
Changed from Default	(Used to view all parameters changed from the default setting.)		N/A	
Direct Access	(Used to access parameter settings from the Direct Access selection of the Program menu.)		N/A	
EOI Option Setups	Contrast (adjustment)	Darker	N/A	
		Lighter	N/A	
	Local/Remote Key	Command	N/A	
		Frequency	N/A	
	Realtime Clock Setup	Date and Time setting (requires RTC option)		N/A
	Preferences	Double Click Speed		N/A
		Arrow Speed		N/A

Program Menu Navigation			
Primary Menu	Sub Menu	Parameter Name	Parameter Number
EOI Option Setups	Preferences	Encoder Speed	N/A
		Pressed Encoder Action	N/A
	Alarm Popups	Overheat Alarm	N/A
		Undervoltage Alarm	N/A
		Over-current Alarm	N/A
		ASD Overload Alarm	N/A
		Motor Overload Alarm	N/A
		Timer	N/A
		Overtorque Alarm	N/A
		DBR Resistor Alarm	N/A
	Lockout	Lockout Reset	N/A
		Lockout Monitor	N/A
		Lockout Run/Stop	N/A
		Lockout Parameter Access	N/A
		Lockout Parameter Write	N/A
		Lockout Frequency Change	N/A
		Lockout Options	N/A
		Lockout Local/Remote	N/A
	Enable Password	N/A	
	Review Startup Screen	(displays the Startup screen)	N/A
Utility Parameters	Versions	Typeform	N/A
		CPU Version	N/A
		Flash Version	N/A
		EEPROM #1 Version	N/A
		EEPROM #2 Version	N/A
		EOI Version	N/A
		Flash Version	N/A
	Display Units	Enable/Disable User-defined Units	N/A
		User-defined Units	N/A
		Hz Per User-defined Unit	F702
		Frequency Display Resolution	F703
		Units for Voltage and Current	N/A
	Type Reset	None	F007
		Auto Setup for 50 Hz	
		Auto Setup for 60 Hz	

Program Menu Navigation			
Primary Menu	Sub Menu	Parameter Name	Parameter Number
Utility Parameters	Type Reset	Restore Factory Defaults	F007
		Clear Trip	
		Clear Run Timer	
		New Base Drive Board	
		Save User Parameters	
		Restore User Parameters	
		Reload EOI Flash	
		Reset EOI Memory	
Terminal Selection Parameters	Input Terminal Functions	F	F111
		R	F112
		ST	F113
		RES	F114
		S1	F115
		S2	F116
		S3	F117
		S4	F118
		S5	F119
		S6	F120
		S7	F121
		12	F122
		13	F123
		14	F124
		15	F125
		16	F126
		ON	F110
	Output Terminal Functions	Out 1	F130
		Out 2	F131
		FL	F132
		4	F133
		5	F134
		6	F135
		7	F136
	Analog Input Functions	Acc/Dec Base Frequency Adjustment	F650
		Upper-limit Frequency Adjustment	F651
		Acceleration Time Adjustment	F652

Program Menu Navigation			
Primary Menu	Sub Menu	Parameter Name	Parameter Number
Terminal Selection Parameters	Analog Input Functions	Deceleration Time Adjustment	F653
		Torque Boost Adjustment	F654
	Reach Settings	Low Speed Signal Output Frequency	F100
		Speed Reach Setting Frequency	F101
	FP Terminal Settings	FP Terminal Meter Selection	F676
		FP Terminal Meter Adjustment	F677
	Input Special Functions	ST Signal Selection	F103
		F/R Priority Selection (w/both on)	F105
		Input Terminal Priority	F106
		Extended Terminal Function	F107
	Line Power Switching	On Trip Selection	F354
		At Frequency Selection	F355
		Inverter-side Wait Time	F356
		Commercial Power Wait Time	F357
		Commercial Power Hold Time	F358
	Input Terminal Delays	F	F140
		R	F141
		ST	F142
		RES	F143
		S1-S4	F144
		S5-S16	F145
		Output Terminal Delays	Out1 On Delay
	Out1 Off Delay		F160
	Out2 On Delay		F151
	Out2 Off Delay		F161
	FL On Delay		F152
	FL Off Delay		F162
	Out4 On Delay		F153
Out4 Off Delay	F163		
Out5 On Delay	F154		
Out5 Off Delay	F164		
Out6 On Delay	F155		
Out6 Off Delay	F165		
Out7 On Delay	F156		
Out7 Off Delay	F166		

Program Menu Navigation			
Primary Menu	Sub Menu	Parameter Name	Parameter Number
<b>Frequency Setting Parameters</b>	Analog Filter	Analog Input Filter	F209
	Speed Ref. Setpoint	VI/II	F201
		RR	F210
		RX	F216
		RX2	F222
		BIN	F228
		PG	F234
	Jog Settings	Jog Run Frequency	F260
		Jog Stop Control	F261
		Jog Window Enable/Disable	N/A
	Preset Speeds	#1 Frequency & Characteristics	F018
		#2 Frequency & Characteristics	F019
		#3 Frequency & Characteristics	F020
		#4 Frequency & Characteristics	F021
		#5 Frequency & Characteristics	F022
		#6 Frequency & Characteristics	F023
		#7 Frequency & Characteristics	F024
		#8 Frequency & Characteristics	F287
		#9 Frequency & Characteristics	F288
		#10 Frequency & Characteristics	F289
		#11 Frequency & Characteristics	F290
		#12 Frequency & Characteristics	F291
		#13 Frequency & Characteristics	F292
		#14 Frequency & Characteristics	F293
		#15 Frequency & Characteristics	F294
	Preset Speed Mode	Use Preset Speed Enable/Disable	F380
	Fwd/Rev Disable	Disable Forward Run/Disable Reverse Run	F311
Motorized Pot Settings	Motorized Pot Setting Disposition at Power Down	F108	
	Minimum Frequency	N/A	
	Maximum Frequency	N/A	
<b>Protection Parameters</b>	Dynamic Braking	Dynamic Braking Enable/Disable & Configuration	F304
	Stall	Over-current Stall Level Configuration	F601
		Over-voltage Stall Enable/Disable	F305
		Over-voltage Stall Level Configuration	N/A

Program Menu Navigation			
Primary Menu	Sub Menu	Parameter Name	Parameter Number
Protection Parameters	Stall	Over-voltage Stall Level Configuration (Fast)	N/A
		Continuing Stall Period (During Positive Torque/Speed)	F452
		Stall Prevention During Regeneration	N/A
	DC Braking	Start Frequency	F250
		DC Braking Current	F251
		DC Braking Time	F252
		Motor Shaft Fixing Control	F253
		Motor Shaft Stationary Control Enable/Disable	F254
	Emergency Off Setting	Emergency Off Mode Configuration	F603
	Retry/Restart Configuration	Number of Retries	F303
		Restart Condition Configuration	F301
	Undervoltage/Ridethrough	Ridethrough Control & Time	F302
		Undervoltage Stall Level	F629
		Undervoltage Trip Configuration	F628
	Overload	OL Reduction Starting Frequency	F606
		Motor 150% OL Time Limit	F607
		Soft Stall Enable/Disable	F017
		Motor Overload Trip	N/A
		V/f Motor Enable/Disable	N/A
	Trip Settings	Trip Save at Power Down Enable/Disable	F602
	Cooling Fan Control	Cooling Fan Control Mode	F620
	Cumulative Run Timer	Cumulative Run Timer Alarm Setting	F621
	Phase Loss	Output Phase Loss Detection Enable/Disable	F605
	Low Current Settings	Low Current Trip/Alarm Configuration	F610
	Abnormal Speed Settings	Abnormal Speed Detection Filter Time	F622
		Overspeed Detection Frequency Range	F623
		Speed Drop Detection Frequency Range	F624
	Arm Short Check Settings	Short Circuit Pulse Run Command	F613
		Short Circuit Pulse Run Command Duration	F614
	Overtorque Settings	Overtorque Trip Enable/Disable	F615
		Overtorque Trip/Alarm Level During Power Operation	F616
Overtorque Trip/Alarm Level During Regeneration		F617	
Overtorque Detection Time		F618	

Program Menu Navigation			
Primary Menu	Sub Menu	Parameter Name	Parameter Number
Protection Parameters	Brake Fault Timer	Brake Fault Internal Timer Time	F630
		Release After Run Time	N/A
	Base Frequency Voltage	Voltage Compensation & Limitation Enable/Disable	F307
	Soft Start	Soft Start Relay Inrush Current Timing and ST Interlock Enable/Disable	F609
Torque Setting Parameters	Torque Reference SetPoints	VI/II	F205
		RR	F214
		RX	F220
		RX2	F226
		BIN	F232
	Torque Control	Torque Command Selection	F420
		Torque Command Filter	F421
		Synchronized Torque Bias Input Selection	F422
		Torque Bias Input Selection	F423
		Load Sharing Gain Selection	F424
	Torque Limit Settings	Running Torque Limit #1 Selection	F440
		Regen Torque Limit #1 Selection	F442
		Manual Settings	N/A
		Torque Limit Mode	F450
	Manual Torque Limits	Torque Limit Mode (Speed Dependent)	F451
		#1 Torque Limit Configuration	F441
		#2 Torque Limit Configuration	F444
		#3 Torque Limit Configuration	F446
	Torque Speed Limiting	#4 Torque Limit Configuration	F448
		Torque Command Mode Selection	F429
		Forward Speed Limit Selection	F425
		Forward Speed Limit Level	F426
		Reverse Speed Limit Selection	F427
		Reverse Speed Limit Level	F428
		Speed Limit Torque Reference Selection	F430
		Speed Limit Torque Level	F431
	Speed Limit Torque Band	F432	
	Speed Limit Torque Recovery Time	F433	

Program Menu Navigation				
Primary Menu	Sub Menu	Parameter Name	Parameter Number	
Feedback Parameters	Feedback Settings	Input Selection	F360	
		Proportional (P) Gain	F362	
		Integral (I) Gain	F363	
		Differential (D) Gain	F366	
		Delay Filter	F361	
		Deviation Limits	F364	
		Position Difference Limit	N/A	
	PG Settings	Number of PG Input Pulses	F367	
		PG Input Phases	F368	
		PG Disconnect Selection	F369	
		Electronic Gear Setting	F370	
		Position Loop Gain	F371	
		Positioning Completion Range	F372	
		Frequency Limit at Position	F373	
		Current Control Proportional Gain	F374	
		Current Control Integral Gain	F375	
		Speed Loop Proportional Gain	F376	
		Speed Loop Integral Gain	F377	
		Motor Counter Data Selection	F378	
		Speed Loop Parameter Ratio	F379	
	Drooping Control	Drooping Gain 100%	F320	
		Speed at Drooping Gain 0%	F321	
		Speed at Drooping Gain 100%	F322	
		Drooping Insensitive Torque Band	F323	
		Drooping Output Filter	F324	
		Drooping Reference	F327	
		Load Inertia	F325	
		Load Torque Filter	F326	
	Override Control	Adding Input Selection	F660	
		Multiplying Input Selection	F661	
		LED Option Override Multiplication Gain	F729	
	Pattern Run Control Parameters	Pattern Run	Pattern Run Mode Enable/Disable and Config.	F520
		Speeds	Pattern #1 Speeds	F530
Pattern #2 Speeds			F540	
Pattern #3 Speeds			F550	

Program Menu Navigation			
Primary Menu	Sub Menu	Parameter Name	Parameter Number
Pattern Run Control Parameters	Speeds	Pattern #4 Speeds	F560
	Preset Speeds	#1 Frequency & Characteristics	F018
		#2 Frequency & Characteristics	F019
		#3 Frequency & Characteristics	F020
		#4 Frequency & Characteristics	F021
		#5 Frequency & Characteristics	F022
		#6 Frequency & Characteristics	F023
		#7 Frequency & Characteristics	F024
		#8 Frequency & Characteristics	F287
		#9 Frequency & Characteristics	F288
		#10 Frequency & Characteristics	F289
		#11 Frequency & Characteristics	F290
		#12 Frequency & Characteristics	F291
		#13 Frequency & Characteristics	F292
		#14 Frequency & Characteristics	F293
#15 Frequency & Characteristics	F294		
Preset Speed Mode	Use Preset Speed Enable/Disable	F380	
Communication Setting Parameters	Communication Settings	Inverter Number	F802
		Logic (TTL) Baud Rate	F800
		RS485 Baud Rate	F820
		Parity	F801
		RS485 Communication Time Out Time	F803
		RS485 Communication Time Out Action	F804
		Internal Communication (logic)	F805
		RS485 Wire Count	F821
		RS485 Response Time	F825
		TTL Master Output Selection	F806
		RS485/232 Master Output Selection	F826
	Communication Reference Adjust	Frequency Point Selection	F810
	S20 Settings	Receive Address	F860
		Transmit Address	F861
		Speed Reference Station	F862
		Speed Reference Address	F863
		Torque Reference Station	F865

Program Menu Navigation			
Primary Menu	Sub Menu	Parameter Name	Parameter Number
<b>Communication Setting Parameters</b>	S20 Settings	Torque Reference Address	F866
		Fault Detect Station Number	F868
		Station Mode	F869
		<b>S20 Reset</b>	F899
		Error Mode	F850
		Error Detect Time	F851
	Scan Receive Settings	#1 Scan Receive	F831
		#2 Scan Receive	F832
		#3 Scan Receive	F833
		#4 Scan Receive	F834
		#5 Scan Receive	F835
		#6 Scan Receive	F836
	Scan Transmit Settings	#1 Scan Transmit	F841
		#2 Scan Transmit	F842
		#3 Scan Transmit	F843
		#4 Scan Transmit	F844
		#5 Scan Transmit	F845
		#6 Scan Transmit	F846
	Communication Error	Sent Command Disposition on Error	F850
	Option Parameters	Optional Parameter #1	F890
		Optional Parameter #2	F891
		Optional Parameter #3	F892
		Optional Parameter #4	F893
		Optional Parameter #5	F894
	<b>Meter Terminal Adjustment Parameters</b>	FM	FM Terminal Assignment
FM Terminal Adjustment			F006
AM		AM Terminal Assignment	F670
		AM Terminal Adjustment	F671
Analog1		Analog 1 Terminal Assignment	F672
		Analog 1 Terminal Adjustment	F673
Analog2		Analog 2 Terminal Assignment	F674
		Analog 2 Terminal Adjustment	F675
<b>Motor Parameters</b>	Vector Motor Model	AutoTune Enable/Disable and Reset Config.	F400
		AutoTune Enable/Disable of Motor Constant 3	F414
		Slip Frequency Gain	F401

Program Menu Navigation			
Primary Menu	Sub Menu	Parameter Name	Parameter Number
<b>Motor Parameters</b>	Vector Motor Model	Motor Constant 1 (primary resistance)	F402
		Motor Constant 2 (secondary resistance)	F403
		Motor Constant 3 (exciting inductance)	F404
		Motor Constant 4 (load inertia)	F405
		Motor Constant 5 (leakage inductance)	F410
	Motor Settings	Number of Motor Poles	F411
		Motor Capacity (kW)	F412
		Motor Type	F413
	Motor Set #1	#1 Base Frequency	F014
		#1 Max Output Voltage	F306
		#1 Torque Boost	F016
		Electronic Thermal Protection Level #1	F600
	Motor Set #2	#2 Base Frequency	F170
		#2 Max Output Voltage	F171
		#2 Torque Boost	F172
		Electronic Thermal Protection Level #2	F173
	Motor Set #3	#3 Base Frequency	F174
		#3 Max Output Voltage	F175
		#3 Torque Boost	F176
		Electronic Thermal Protection Level #3	F177
Motor Set #4	#4 Base Frequency	F178	
	#4 Max Output Voltage	F179	
	#4 Torque Boost	F180	
	Electronic Thermal Protection Level #4	F181	
<b>Monitor Setup</b>	Trip History	Trip History	N/A
	Trip Monitor from ASD	Most Recent	N/A
		Second Most Recent	N/A
		Third Most Recent	N/A
		Fourth Most Recent	N/A
	Scrolling Monitor Select	Scrolling Monitor Select	N/A
<b>Special Control Parameters</b>	Frequency Control	Start Frequency	F240
		End Frequency	F243
		Run Frequency	F241
		Run Frequency Hysteresis	F242
	Jump Frequencies	Jump Frequency Bandwidth Settings	F271

Program Menu Navigation				
Primary Menu	Sub Menu	Parameter Name	Parameter Number	
Special Control Parameters	Jump Frequencies	Jump Frequency Processing Selection	F276	
	Carrier Frequency	PWM Carrier Frequency Adjustment	F300	
	Accel/Decel Settings	Accel/Decel #1 Configuration	F009	
	Accel/Decel #1 – #4 Settings		Accel/Decel #2 Configuration	F500
			Accel/Decel #3 Configuration	F510
			Accel/Decel #4 Configuration	F514
	Accel/Decel Special		S-Pattern Lower Limit Adjustment	F506
			S-Pattern Upper Limit Adjustment	F507
			Accel/Decel Time Lower Limit	F508
			Accel/Decel Switching Frequency #1	F505
			Accel/Decel Switching Frequency #2	F513
			Accel/Decel Switching Frequency #3	F517
			Display Resolution	N/A
	Crane/Hoist Load		High-Speed Operation at Low Load	N/A
			Light-load High-speed Operation Switching Lower Limit Frequency	N/A
			Light-load High-speed Operation Load Waiting Time	N/A
			Light-load High-speed Operation Load Detection Time	N/A
			Light-load High-speed Operation Heavy Load Detection Time	N/A
			Switching Load Torque During Forward Run	N/A
			Heavy Load Torque During Deceleration in the Forward Direction	N/A
			Heavy Load Torque During Acceleration in the Forward Direction	N/A
			Switching Load Torque During Reverse Run	N/A
			Heavy Load Torque During Deceleration in the Reverse Direction	N/A
			Heavy Load Torque During Acceleration in the Reverse Direction	N/A
			Frequency for Automatic High-speed Operation at Low Load	N/A
		Backlash Setup	Not available.	N/A
		V/f Five Point Setting		#1 Frequency Setting
			#1 Voltage Setting	F191
			#2 Frequency Setting	F192

Program Menu Navigation			
Primary Menu	Sub Menu	Parameter Name	Parameter Number
Special Control Parameters	V/f Five Point Setting	#2 Voltage Setting	F193
		#3 Frequency Setting	F194
		#3 Voltage Setting	F195
		#4 Frequency Setting	F196
		#4 Voltage Setting	F197
		#5 Frequency Setting	F198
		#5 Voltage Setting	F199
	Special Parameters	V/f Adjustment Coefficient	F183
		0 Hz Dead Band Frequency Setting Signal	F244
		0 Hz Command Stop Function	F255
		Over Exciting Cooperation	F481
		Stall Cooperation Gain at Field Weakening Zone	N/A
		Exciting Starting Rate	N/A
		Compensation Coefficient for Iron Loss	N/A
		Voltage Compensation Coefficient for Dead Time	N/A
		Dead Time Compensation	N/A
		Dead Time Compensation Bias	N/A
		Switching Frequency Between Current and Voltage	N/A
		Optional Analog Terminal Mark	N/A
		Current Differential Gain	F454
		Exciting Strengthening Coefficient	F480
		Enable/Disable User Parameter Initialization During Typeform Initialization	N/A
		Current Vector Control	F482
		Voltage Vector Control	F483
		Constant Vector Control	F484

# Appendix A

## Enclosure Dimensions and Conduit Plate Information

### G7 Part Numbering Convention.

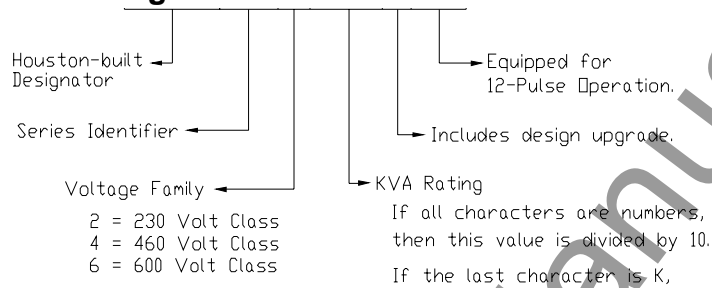

**Note:** The Type 1 enclosed versions of these drives meet or exceed the specification **UL 1995, the Standard for Heating and Cooling Equipment**, and complies with the applicable requirements for installation in a compartment handling conditioned air.

## Enclosure Dimensions/Weight

Table 4.

Model Number VT130G7U	Fig.	A (in/mm)	B (in/mm)	C (in/mm)	D (in/mm)	E (in/mm)	F (in/mm)	G (in/mm)	H (in/mm)	Unit Weight (lbs.)	Shipping Weight (lbs.)	Conduit Plate Number (see pg. 39 and 40)	
												Bottom	Top
2010	9	8.47/215	7.28/185	7.33/186	8.47/215	7.95/202	6.74/171	0.53/13	0.23/6	10	12	49462	N/A
2015													
2025													
2035													
2055													
2080													
2110	10	14.22/361	12.16/309	11.23/285	14.22/361	13.05/331	11.46/291	0.55/14	0.28/7	41	48	49033	N/A
2160													
2220													
2270													
2330	10	24.5/603	17.5/445	13.0/292	21.75/552	22.75/578	14.0/356	0.75/19	0.63/16	80	111	51288	N/A
4015	9	8.47/215	7.28/185	7.33/186	8.47/215	7.95/202	6.74/171	0.53/13	0.23/6	11	13	49462	N/A
4025													
4035													
4055													
4080													
4110													
										13	15		N/A

Table 4. (Continued)

Model Number VT130G7U	Fig.	A (in/mm)	B (in/mm)	C (in/mm)	D (in/mm)	E (in/mm)	F (in/mm)	G (in/mm)	H (in/mm)	Unit Weight (lbs.)	Shipping Weight (lbs.)	Conduit Plate Number (see pg. 39 and 40)	
												Bottom	Top
4160	9	14.22/361	12.16/309	11.23/285	14.22/361	13.05/331	11.46/291	0.55/14	0.28/7	43	50	49033	N/A
4220										45	52		
4270										46	53		
4330										47	54		
4400										51	58		
4500	10	23.75/603	17.5/445	11.5/292	21.75/552	22.75/578	14.0/356	0.75/19	0.63/16	90	121	50097	N/A
4600		36.50/927	19.25/489	13.56/344	33.88/861	35.34/898	12.63/321	0.75/19	0.63/16	151	202	51288	N/A
4750													
410K		57.00/1448	19.25/489	13.16/334	54.16/1376	55.81/1418	12.63/321	0.75/19	0.69/18	232	305	51314	51313
412K										242	315	51325	
415K	251									325	51328		
420K	274									345	51328		
425K	11	59.94/1522	25.88/657	14.47/368	57.00/1448	58.75/1492	11.81/300	0.75/19	0.69/18	391	472	51332	51333
430K	12	73.00/1854	24.00/610	20.00/508	68.00/1727	71.00/1803	16.00/406	0.75/19	0.69/18	525	665	51340	51339
435K													
6015	9	8.47/215	7.28/185	7.33/186	8.47/215	7.95/202	6.74/171	0.53/13	0.23/6	11	13	49462	N/A
6025													
6035													
6060													
6080													
6120													
6160													
6220	10	23.63/600	17.38/441	11.50/292	21.63/549	22.75/578	14.25/362	0.75/19	0.50/13	73	104	51394	N/A
6270										80	111		
6330	10	36.50/927	19.25/489	13.56/344	33.88/861	35.34/898	12.63/321	0.75/19	0.63/16	125	178	51288	N/A
6400										127	180		
6500													
6600													
6750													
610K	57.00/1448	19.25/489	13.16/334	54.16/1376	55.81/1418	12.63/321	0.75/19	0.69/18	221	295	51314	51313	
612K													
615K	11	59.94/1522	25.88/657	14.47/368	57.40/1449	58.75/1492	11.81/300	0.75/19	0.69/18	TBD	TBD	51332	51333
620K										358	500		
625K										369	510		

Figure 9.

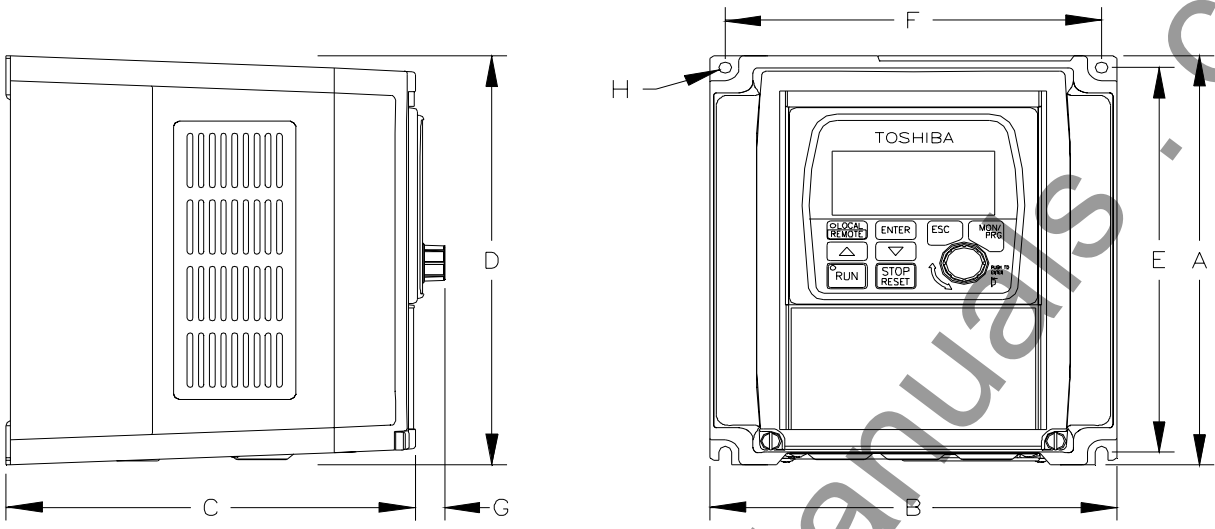

Figure 10.

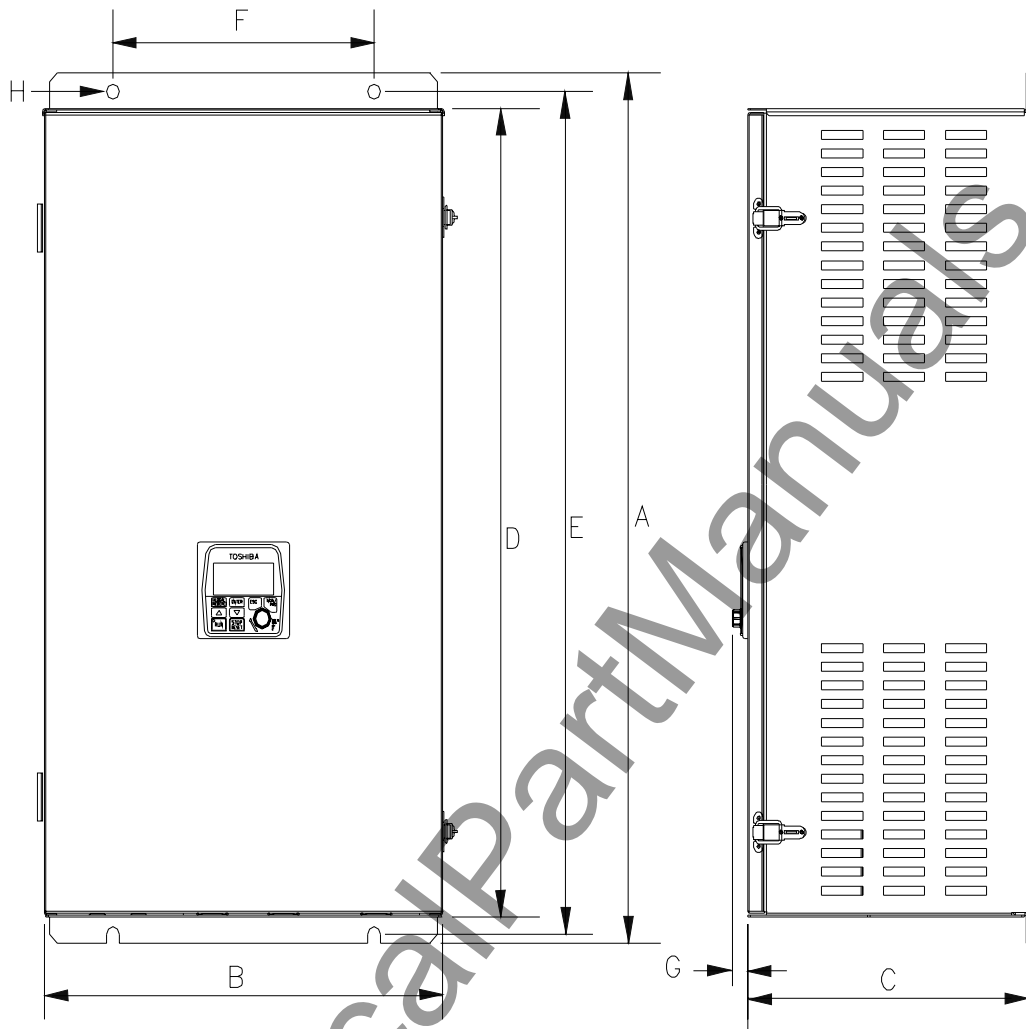

Figure 11.

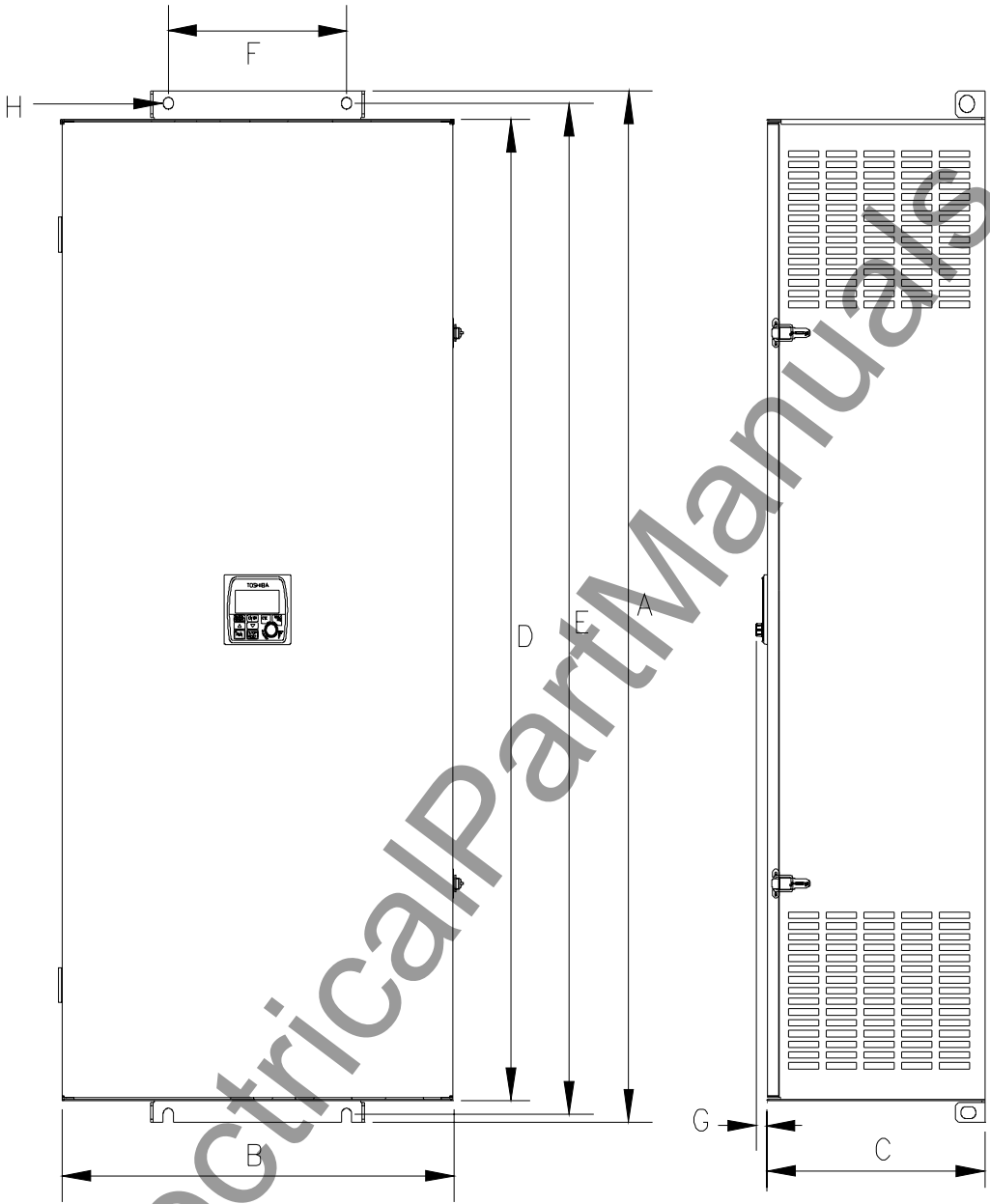
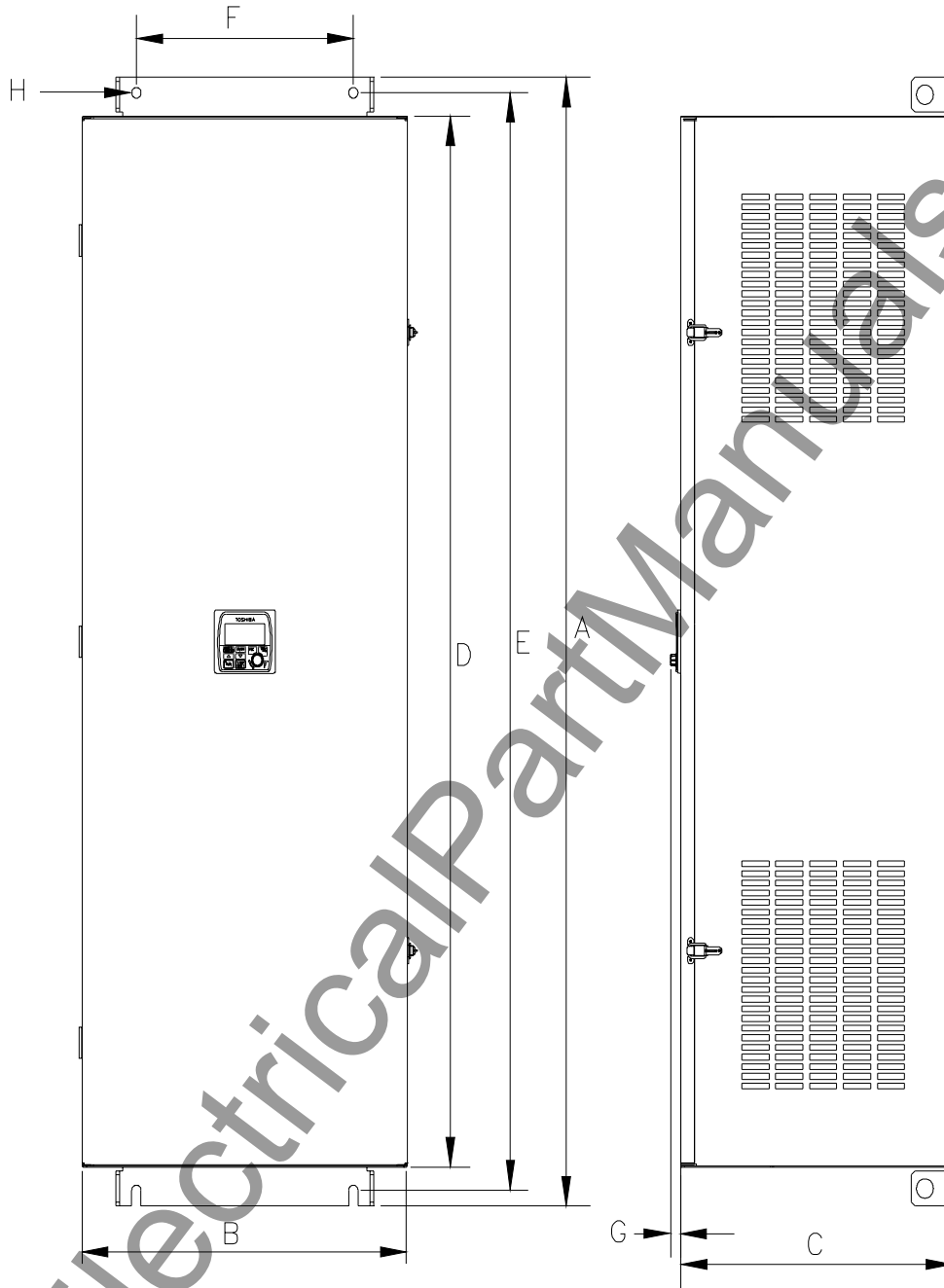

Figure 12.



# Conduit Plate Information

The conduit plate information provided below is for the 0.75 to 350 HP **G7 ASDs** of the 230, 460, and 600 volt product lines. Each bottom or top conduit plate may be cross referenced to the applicable device using the information in Table 4 on page 33.

**Note:** Unless otherwise specified, all dimensions are in inches.

Figure 13.

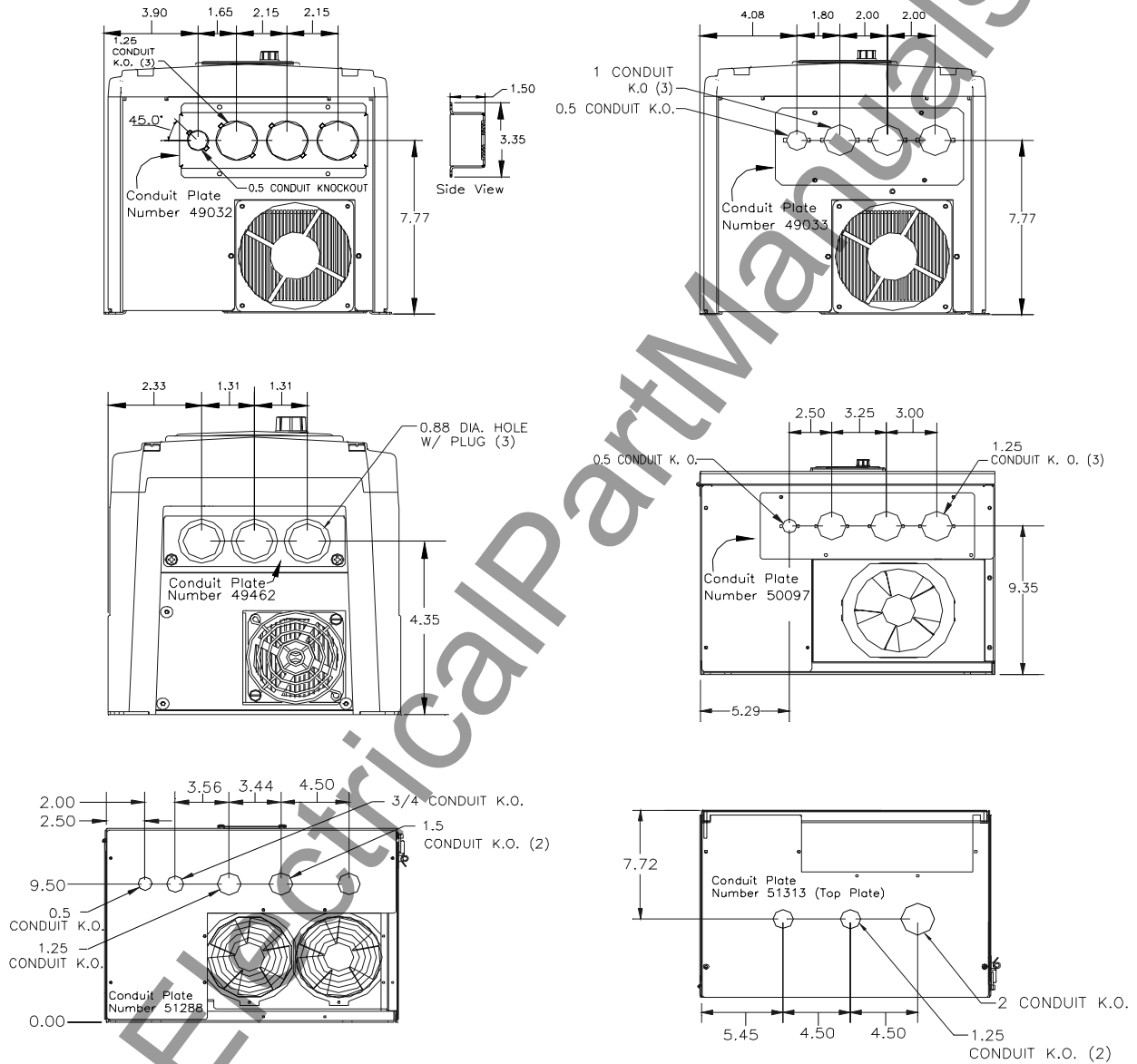
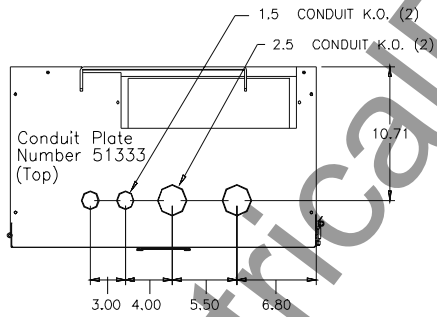
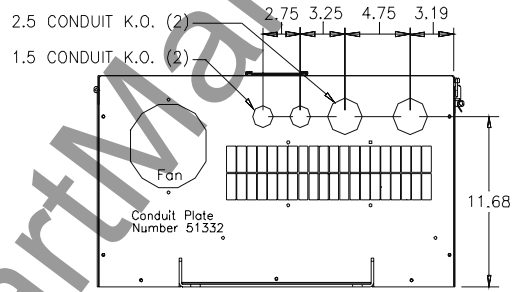
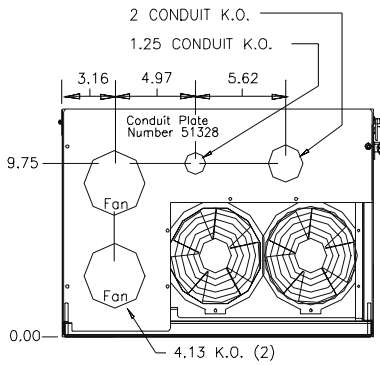
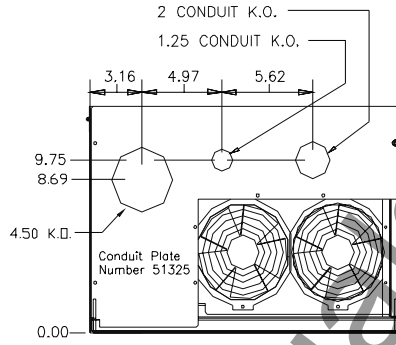
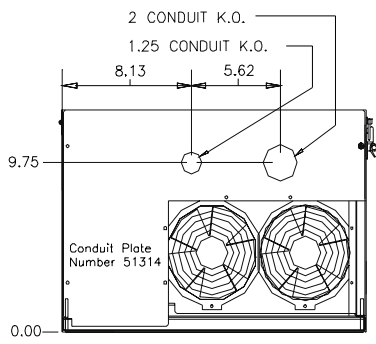
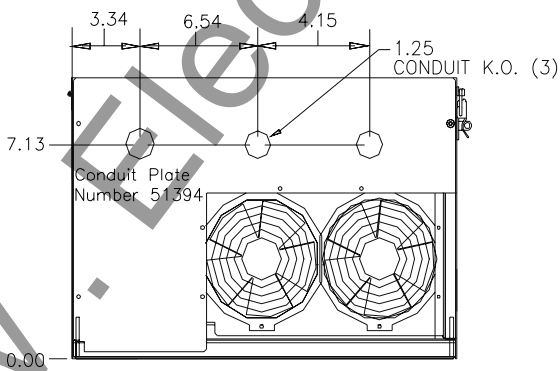
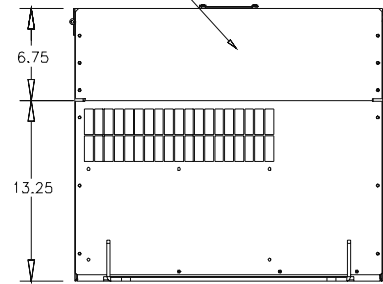

Figure 14.



Conduit Plate Number 51339 and 51340 - NOT PREPUNCHED



## Conduit Extender Box (option)

The Conduit Extender Box (P/N ASD-Conduit-1) may be used when more room is required at the ASD conduit connection point. This option makes adding and removing conduit easier and quicker.

### Installation

1. Remove the Conduit Plate 49462.
2. Install the Conduit Extender Box 53354, reusing the 2 screws from the conduit plate.
3. Make the conduit and wiring connections.
4. Install the Conduit Extender Box cover 53355.

Figure 15. Conduit Extender Box.

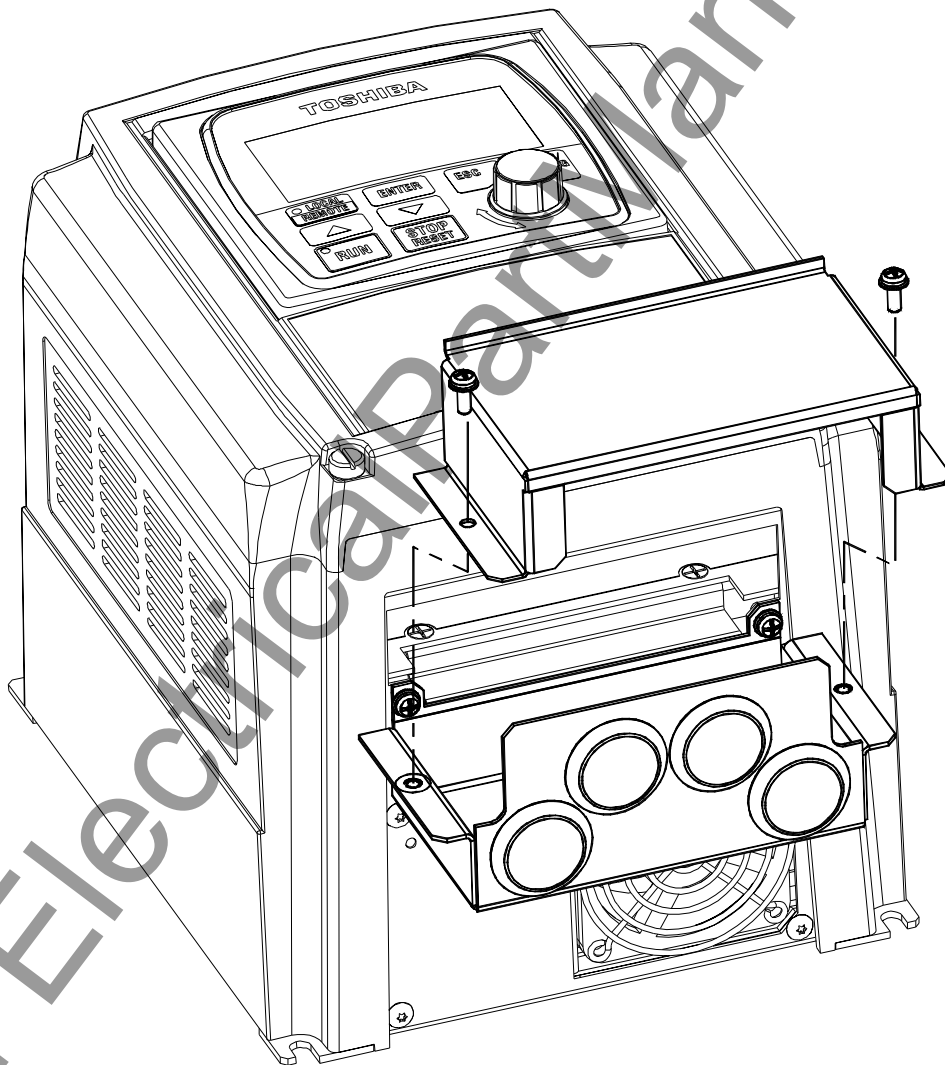

# Appendix B

## EOI Remote Mounting

The G7 ASD may be controlled from a remote position via the EOI. For safety and application-specific reasons, some ASD installations will warrant that the operator not be in the vicinity during operation or that the EOI not be attached to the ASD housing. The EOI may be mounted either with or without the optional G7 Remote Mounting Kit (P/N ASD-MTG-KIT). The ease of installation is enhanced by the G7 Remote Mounting Kit which allows for easier cable routing and EOI placement.

The EOI may be mounted up to 15 feet away from the ASD and will provide the full range of functions that are available if the EOI were ASD-mounted.

Remote mounting will also allow for multiple EOI mountings at one location or one EOI may be switched between multiple ASDs. Controlling and monitoring several ASDs via an EOI may be accomplished from a central location.

The optional dust cover (P/N ASD-BPC) may be used to cover the front panel opening of the ASD housing after removing the EOI. An EOI extender cable is required for remote mounting. EOI extender cables are available in lengths of 7, 10, or 15 feet lengths and may be ordered through your sales representative.

## Remote EOI Required Hardware

### EOI Mounting Hardware

- 6-32 x 5/16 Pan Head Screw — P/N 50595 (4 ea.)
- #6 Split-Lock Washer — P/N 01884 (4 ea.)
- #6 Flat Washer — P/N 01885 (4 ea.)

### Bezel Plate Mounting Hardware

- Bezel Plate — P/N 52291
- 10-32 Hex Nut — P/N 01922 (4 ea.)
- #10 Split-Lock Washer — P/N 01923 (4 ea.)
- #10 Flat Washer — P/N 01924 (4 ea.)
- Dust Cover — P/N ASD-BPC (Optional)

### Extender Cables

- ASD-CAB7F: ASD, OPN, G7, EOI, Cable, RJ45, 7 Ft.
- ASD-CAB10F: ASD, OPN, G7, EOI, Cable, RJ45, 10 Ft.
- ASD-CAB15F: ASD, SPN, G7, EOI, Cable, RJ45, 15 Ft.

## EOI Installation Precautions

Install the unit securely in a well ventilated area that is out of direct sunlight using the four mounting holes of the EOI. The ambient temperature rating for the EOI is 14 to 104° F (-10 to 40° C).

- Select a mounting location that is easily accessible by the user.
- Avoid installation in areas where vibration, heat, humidity, dust, metal particles, or high levels of electrical noise (EMI) are present.
- Do not install the EOI where it may be exposed to flammable chemicals or gasses, water, solvents, or other fluids.
- Turn the power on only after securing the front cover to the ASD.

## EOI Remote Mounting w/o the ASD-MTG-KIT

**Note:** See Figure 16 for the dimensions and the item locations referenced in steps 1 through 5.

1. At the EOI mounting location, identify and mark the location of the 3.80" by 3.29" hole and the 7/32" screw holes.
2. Cut the 3.80" by 3.29" rectangular hole.
3. Drill the four 7/32" screw holes.
4. Attach and secure the EOI to the front side of the mounting location using the four 6-32 x 5/16 pan head screws, the #6 split lock washers, and the #6 flat washers.
5. Connect the RJ-45 extension cable(s).

## EOI Dimensions (mounting)

Figure 16. EOI Mounting Dimensions.

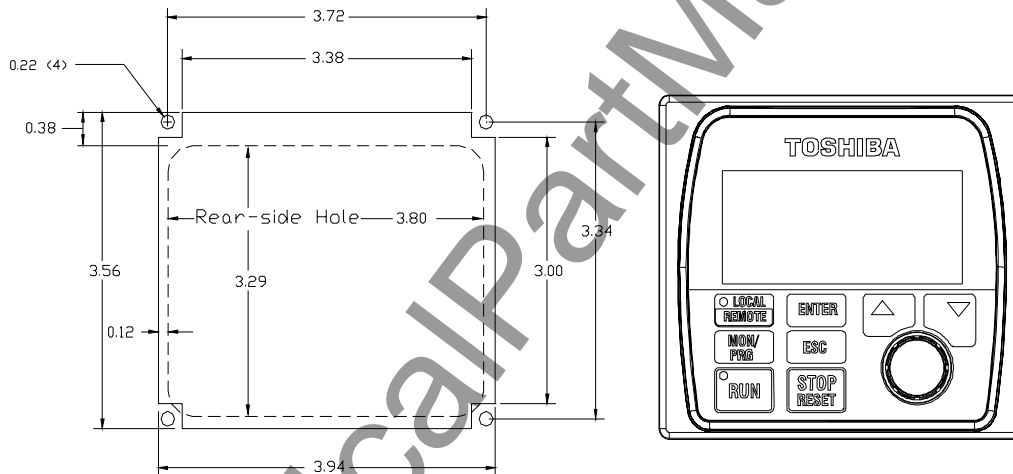

## EOI Remote Mounting using the ASD-MTG-KIT

**Note:** See Figures 17 and 18 for the dimensions and the item locations referenced in steps 1 through 6.

1. At the EOI mounting location, identify and mark the locations of the 5.00" by 4.60" hole and the four 11/32" screw holes.
2. Cut the 5.00" by 4.60" rectangular hole.
3. Drill the four 11/32" holes.
4. Attach and secure the Bezel plate to the front side of the mounting location using the four 10-32 hex nuts, #10 split lock washers, and the #10 flat washers.
5. Attach and secure the EOI to the front side of the Bezel plate using the four 6-32 x 5/16 pan head screws, #6 split lock washers, and the #6 flat washers.
6. Connect the RJ-45 extension cable(s).

## EOI ASD-MTG-KIT Dimensions (mounting)

Figure 17. EOI Bezel Plate Mounting Dimensions.

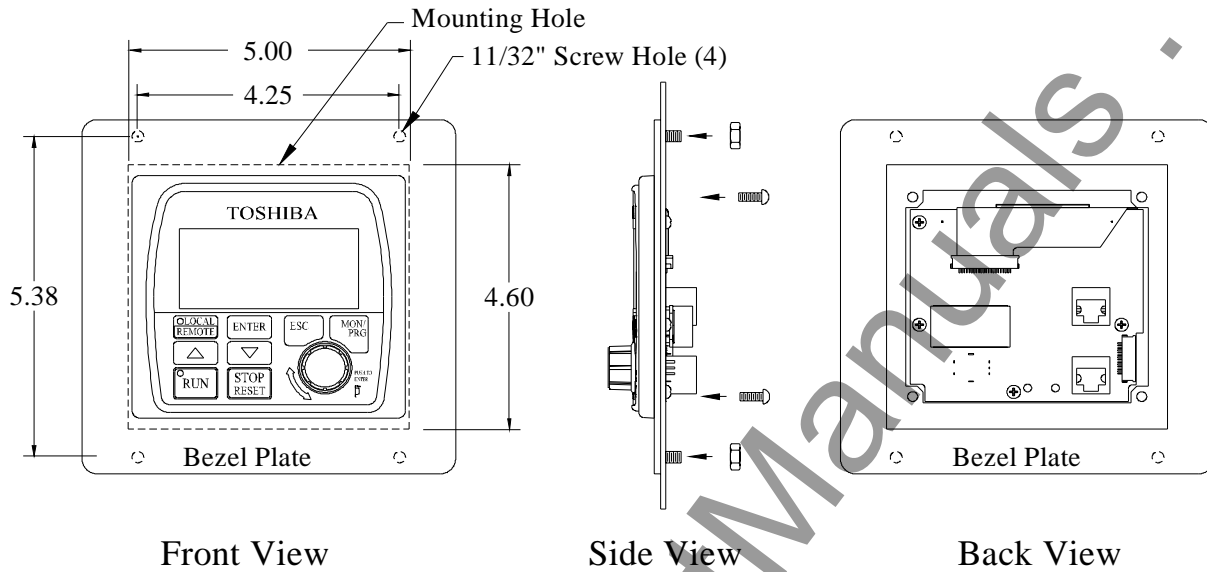

Figure 18. Screw Length Precaution.

**CAUTION:** Failure to use the correct hardware may result in damage to the outer surface of the EOI panel and/or improper seating of the panel to the bezel plate. Use caution when mounting the EOI assembly to ensure that the internal thread clearance is maintained.



# Appendix C

## Current/Voltage Specifications

Table 5. 230 Volt NEMA Type-1 Chassis standard ratings table.

Model VT130G7U	Rated KVA	Motor HP/Kw	Input Voltage 3-Ph 50/60 ± 2 Hz	Output Voltage 3-Ph Variable Frequency	Output Current 100/110% Cont.	Overload Current 150% for 120 Secs.
2010	1.00	0.75/0.56	200–240 VAC (±10%)	Input Voltage Level (Max.)	3.50/3.85 A	5.25 A
2015	1.50	1.00/0.75			5.00/5.50 A	7.50 A
2025	2.50	2.00/1.49			7.00/7.70 A	10.5 A
2035	3.50	3.00/2.24			10.0/11.0 A	15.0 A
2055	5.50	5.00/3.73			16.0/17.6 A	24.0 A
2080	8.00	7.50/5.60			23.0/25.3 A	34.5 A
2110	11.0	10.0/7.46			30.0/33.0 A	45.0 A
2160	16.0	15.0/11.2			45.0/49.5 A	67.5 A
2220	22.0	20.0/14.9			60.0/66.0 A	90.0 A
2270	27.0	25.0/18.5			71.0/78.1 A	106.5 A
2330	33.0	30.0/22.0			90.0/99.0 A	135.0 A

Table 6. 460 Volt NEMA Type-1 Chassis standard ratings table.

Model VT130G7U	Rated KVA	Motor HP/Kw	Input Voltage 3-Ph 50/60 ± 2 Hz	Output Voltage 3-Ph Variable Frequency	Output Current 100/ 110% Cont.	Overload Current 150% for 120 secs.	Overload Current 130% for 60 secs.
4015	1.50	1.00/0.75	380 – 480 VAC (±10%)	Input Voltage Level (Max.)	2.70/3.00 A	4.05 A	N/A
4025	2.50	2.00/1.49			3.50/3.90 A	5.25 A	
4035	3.50	3.00/2.24			5.00/5.50 A	7.50 A	
4055	5.50	5.00/3.73			8.00/8.80 A	12.0 A	
4080	8.00	7.50/5.60			11.5/12.7 A	17.3 A	
4110	11.0	10.0/7.46			15.0/16.5 A	22.5 A	
4160	16.0	15.0/11.2			23.0/25.3 A	34.5 A	
4220	22.0	20.0/14.9			30.0/33.0 A	45.0 A	
4270	27.0	25.0/18.5			38.0/41.8 A	57.0 A	
4330	33	30.0/22.0			45.0/49.5 A	67.5 A	
4400	40	40.0/30.0			57.0/62.7 A	85.5 A	

**Table 6. (Continued) 460 Volt NEMA Type-1 Chassis standard ratings table.**

Model VT130G7U	Rated KVA	Motor HP/Kw	Input Voltage 3-Ph 50/60 ± 2 Hz	Output Voltage 3-Ph Variable Frequency	Output Current 100/ 110% Cont.	Overload Current 150% for 120 secs.	Overload Current 130% for 60 secs.
4500	50	50.0/37.0	380 – 480 VAC (±10%)	Input Voltage Level (Max.)	71.0/78.1 A	106.5 A	N/A
4600	60	60.0/45.0			83.0/91.3 A	124.5 A	
4750	75	75.0/55.0			104.0/114.4 A	156.0 A	
410K	100	100/75.0			138.0/151.8 A	207.0 A	
412K	125	125/90.0			172.0/189.2 A	N/A	233.6 A
415K	150	150/110			206.0/226.6 A		267.8 A
420K	200	200/150			275.0/302.5 A		357.5 A
425K	250	250/185			343.0/377.3 A		445.9 A
430K	300	300/220			415.0/456.5 A		539.5 A
435K	350	350/243			420.0/462.0 A		546.0 A

**Table 7. 600 Volt NEMA Type-1 Chassis standard ratings table.**

Model VT130G7U	Rated KVA	Motor HP/Kw	Input Voltage 3-Ph 50/60 ±2 Hz	Output Voltage 3-Ph Variable Frequency	Output Current 100/110% Cont.	Overload Current 150% for 120 Secs.	Overload Current 130% for 60 Secs.
6015	1.50	1.00/0.75	495 – 600 VAC (+5/-10%)	Input Voltage Level (Max.)	2.1/2.30 A	3.20 A	N/A
6025	2.50	2.00/1.49			3.0/3.30 A	4.50 A	
6035	3.50	3.00/2.24			4.0/4.40 A	6.00 A	
6060	6.00	5.00/3.73			6.1/6.70 A	9.20 A	
6080	8.00	7.50/5.60			9.0/9.90 A	13.5 A	
6110	11.0	10.0/7.46			12.0/13.2 A	18.0 A	
6160	16.0	15.0/11.2			17.0/8.7 A	25.5 A	
6220	22.0	20.0/14.9			22.0/26.4 A	33.0 A	
6270	27.0	25.0/18.5			27.0/29.7 A	40.5 A	
6330	33.0	30.0/22.0			32.0/35.2 A	48.0 A	
6400	40.0	40.0/30.0			41.0/45.1 A	61.5 A	
6500	50.0	50.0/37.0	52.0/57.2 A	78.0 A			
6600	60.0	60.0/45.0	62.0/68.2 A	93.0 A			
6750	75.0	75.0/55.0	77.0/84.7 A	115.5 A			
610K	100	100/75.0	99.0/108.9 A	148.5 A			
612K	125	125/90.0	125.0/137.5 A	N/A	162.5 A		
615K	150	150/110	150.0/165.0 A		195.0 A		
620K	200	200/150	200.0/220.0 A		260.0 A		
625K	250	250/185	250.0/275.0 A		325.0 A		

# Appendix D

## Dynamic Braking Resistor Installation Guidelines

Because the heat generated by the resistor will affect the cooling capacity of the heatsink, the resistor pack should be mounted above or to the side of the ASD — **Never below the ASD**. Maintain a minimum of six inches between the resistor pack and the ASD unit.

Heavy duty DBRs should be wired using the same gauge wire as the motor leads. Light duty DBRs may use one wire size smaller (AWG) than the motor leads.

The total wire length from the ASD to the DBR should not exceed ten feet.

The wiring from the ASD to the DBR should be twisted approximately two twists per foot throughout the length of the wire.

If EMI/RFI noise is of concern, the DBR wiring should be three-core screened cable. The screen should connect to the ASD enclosure and the resistor enclosure.

## Cable/Terminal Specifications

Table 8. 230 Volt Drive Cable/Terminal Specifications.

Model VT130G7U	Circuit Breaker Rating (Amps)	Typical Wire/Cable Size (AWG)			Lug Size
		Input/Output Power	AM, FM, and II Terminals	Control Terminal Strip	ASD Input/Output Power Lug Wire Capacity
2010	15	#14	#20 (3-core shield)	#18 (2-core shield)	8 to 24 AWG
2015	15	#14			
2025	15	#14			
2035	20	#14			
2055	30	#14			
2080	50	#10			
2110	70	#8			
2160	90	#6			
2220	100	#4			
2270	125	#3			
2330	150	#1			14-1/0
					6-250

Table 9. 460 Volt Drive Cable/Terminal Specifications.

Model VT130G7U	Circuit Breaker Rating (Amps)	Typical Cable Size (AWG)			Lug Size
		Input/Output Power Wire Size	AM, FM, and II Terminals	Control Terminal Strip	ASD Input/Output Power Lug Wire Capacity
4015	15	#14	#20 (3-core shield)	#18 (2-core shield)	8 to 24 AWG
4025	15	#14			
4035	15	#14			
4055	15	#14			
4080	30	#14			
4110	30	#14			

Table 9. 460 Volt Drive Cable/Terminal Specifications.

Model VT130G7U	Circuit Breaker Rating (Amps)	Typical Cable Size (AWG)			Lug Size
		Input/Output Power Wire Size	AM, FM, and II Terminals	Control Terminal Strip	ASD Input/Output Power Lug Wire Capacity
4160	40	#10	#20 (3-core shield)	#18 (2-core shield)	4 to 18
4220	50	#8			
4270	70	#8			
4330	90	#6			
4400	100	#4			
4500	100	#3			14 to 1/0
4600	125	#2			6 to 250
4750	175	#1			
410K	200	#2/0			
412K	225	#4/0			
415K	300	*#2/0			
420K	350	*#4/0			
425K	400				
430K	600	*#350			
435K	700	*#400			1/0 to 500

Note: (\*) Indicates that the item is one of a set of two parallel cables.

Table 10. 600 Volt Drive Cable/Terminal Specifications.

Model VT130G7U	Circuit Breaker Rating (Amps)	Typical Cable Size (AWG)			Lug Size	
		Input/Output Power Wire Size	AM, FM, and II Terminals	Control Terminal Strip	ASD Input/Output Power Lug Wire Capacity	
6015	15	#14	#20 (3-core shield)	#18 (2-core shield)	8 to 24 AWG	
6025	15	#14				
6035	15	#14				
6060	15	#14				
6080	20	#14				
6120	30	#14				
6160	35	#12				
6220	50	#10				18-2/14-2
6270	60	#10				
6330	70	#8				
6400	90	#6				
6500	100	#6				
6600	100	#4				
6750	125	#3				
610K	175	#1			6-250	
612K	200	#2/0				
615K	225	#3/0				
620K	300	*#2/0				
625K	400	*#4/0				

Note: (\*) Indicates that the item is one of a set of two parallel cables.

# Index

#1 Base Frequency, 20

## A

Abnormal Speed Settings, 25  
Accel/Decel #1 – #4 Settings, 31  
Accel/Decel #1 Settings, 20  
Accel/Decel Settings, 31  
Accel/Decel Special, 31  
Adjust Accel/Decel Automatically, 14  
Adjustable Speed Drive Inspection, 3  
Alarm Popups, 21  
AM, 29  
Analog Filter, 24  
Analog Input Functions, 22, 23  
Analog1, 29  
Analog2, 29  
Appendix A, 33  
Appendix B, 42  
Appendix C, 45  
Appendix D, 47  
Arm Short Check Settings, 25

## B

Backlash Setup, 31  
Base Frequency Volts, 26  
Bezel Mounting Dimensions, 44  
Bezel Mounting Hardware, 42  
Brake Fault Timer, 26

## C

Cable/Terminal Specifications, 47  
Carrier Frequency, 31  
Changed from Default, 20  
Changed From Default screen, 13  
Circuit breaker configuration, 5  
Command Source, 15  
Communication Error, 29  
Communication Reference Adjust, 28  
Communication Setting Parameters, 28, 29  
Communication Settings, 28  
concerns about this publication, 2  
Conduit Extender Box, 41

Conduit Plate Information, 33, 39  
Configuration and Menu Options, 17  
Connecting the ASD, 6  
Connection Diagram, 9  
Contrast (adjustment), 20  
Control Terminal Strip, 8  
Crane/Hoist Load, 31  
Cumulative Run Timer, 25  
Current/Voltage Specifications, 45

## D

DBR Installation Guidelines, 47  
DC Braking, 25  
Default Setting Changes, 13  
Default Term. Setting, 8  
Direct Access, 20  
Display Units, 21  
Disposal, 3  
Down Key, 10  
Drooping Control, 27  
Dynamic Braking, 24

## E

Electronic Operator Interface, 10  
Emergency Off Setting, 25  
Enclosure Dimensions, 33  
Enclosure Dimensions/Weight, 33  
Encoder Speed, 21  
Enter Key, 10  
EOI Bezel Mounting Dimensions, 44  
EOI Bezel Plate Dimensions (mounting), 44  
EOI Dimensions (mounting), 43  
EOI Features, 10  
EOI Installation Precautions, 42  
EOI Mounting Dimensions, 43  
EOI Operation, 11  
EOI Remote Mounting using the ASD-MTG-KIT, 43  
EOI Remote Mounting w/o the ASD-MTG-KIT, 43  
EOI Setup Options, 20  
Escape Key, 10  
Extender Cables, 42

## F

F, 22  
Fan Control, 25  
Fault Status, 19  
Feedback Parameters, 27  
Feedback Settings, 27  
FM, 29  
FP Terminal Settings, 23  
Frequency Command screen, 12  
Frequency Control, 30  
Frequency Mode #2, 20  
Frequency Reference Source, 15  
Frequency Set Mode, 17  
Frequency Setting, 20  
Frequency Setting Parameters, 24  
Fundamental Parameters, 20  
Fwd/Rev Disable, 24

## G

G7 Part Numbering Convention, 33

## I

I/O and Control, 8  
II, 8  
Initial Setup, 12  
Input Special Functions, 23  
Input Terminal Assignment, 22  
Input Terminal Delays, 23  
Installation and Connections, 4  
Installation Notes, 4  
Installation Precautions, 1

## J

Jog Settings, 24  
Jump Frequencies, 30

## L

L1/R, 6  
L2/S, 6  
L3/T, 6  
LCD Display, 10  
Lead Length Specifications, 7

Line Power Switching, 23  
Local Remote Key, 20  
Local/Remote Key, 10  
Lockout, 21  
Low Current Settings, 25  
Lower Limit, 20  
Lower Limit Frequency, 14

## M

Maintenance Precautions, 2  
Manual Torque Limits, 26  
Maximum Frequency, 20  
Meter Terminal Adjustment Parameters, 29  
MON/PRG, 11  
Monitor Mode, 18  
Monitor Setup, 30  
Motor connection diagram, 6  
Motor Current Rating, 15  
Motor Overload Trip, 25  
Motor Parameters, 29, 30  
Motor Set #1, 20, 30  
Motor Set #2, 30  
Motor Set #3, 30  
Motor Set #4, 30  
Motor Settings, 30  
Motorized Pot Settings, 24  
Mounting the ASD, 5

## O

Operation, 12  
Option Type, 19  
Out1 Out2 FL, 18  
Output Terminal Delays, 23  
Output Terminals, 22  
Overload, 25  
Override Control, 27  
OverTorque Settings, 25

## P

PA, 6  
Panel Menu, 18  
Pattern Run, 27  
Pattern Run Control Parameters, 27  
PG, 24

PG Settings, 27  
Phase Loss, 25  
PO, 6  
Power Connections, 6  
Preferences, 20  
Preset Speed Mode, 24, 28  
Preset Speeds, 24, 28  
Pressed Encoder Action, 21  
Program Menu Navigation, 20  
Program Mode, 20  
Protection Parameters, 24

## R

R, 22  
Reach Settings, 23  
Realtime Clock Setup, 20  
Remote EOI Required Hardware, 42  
RES, 22  
Retry/Restart Configuration, 25  
Review Startup Screen, 21  
Root menu mapping, 17  
Root Menus, 17  
Rotary Encoder, 11  
RR, 24  
Run Key, 10  
RX, 24

## S

S1, 22  
S2, 22  
S3, 22  
S4, 22  
Safety Precautions, 1  
Scrolling Monitor, 17  
Scrolling Monitor Select, 30  
Service Life Information, 2  
SetPoints, 26  
Shipping Weight, 33  
Shipping Weight (lbs.), 33  
Soft Stall Enable, 25  
Soft Start, 26  
Special Control Parameters, 30  
Special Parameters, 32  
Speed Ref. Setpoint, 24  
Speeds, 27  
ST, 22

Stall, 24  
Standard Mode Settings, 20  
Startup and Test, 7  
Startup Wizard, 20  
Startup Wizard Requirements, 14  
Status LED, 10  
Stop Key, 10  
Storage, 3  
System Grounding, 6  
System Operation, 12

## T

T1/U, 6  
T2/V, 6  
T3/W, 6  
Terminal Selection Parameters, 22  
Torque Control, 26  
Torque Limit Settings, 26  
Torque Setting Parameters, 26  
Torque Speed Limiting, 26  
Trip History, 30  
Trip Monitor from ASD, 30  
Trip Settings, 25  
Type Reset, 21

## U

Undervoltage/Ridethrough, 25  
Unit Weight, 33  
Up Key, 10  
Upper Limit, 20  
Upper Limit Frequency, 14  
Utility Parameters, 21

## V

V/f Five Point Setting, 31  
Vector Motor Model, 29  
Versions, 21  
VI/II, 24  
Voltage and Frequency Rating of the Motor, 14  
Volts per Hertz Setting, 15

## W

Wizard Finish, 16