

# Instructions for A900 Size 3 or 4, Two-Speed Motor Controller

I.L. 16969

Model J

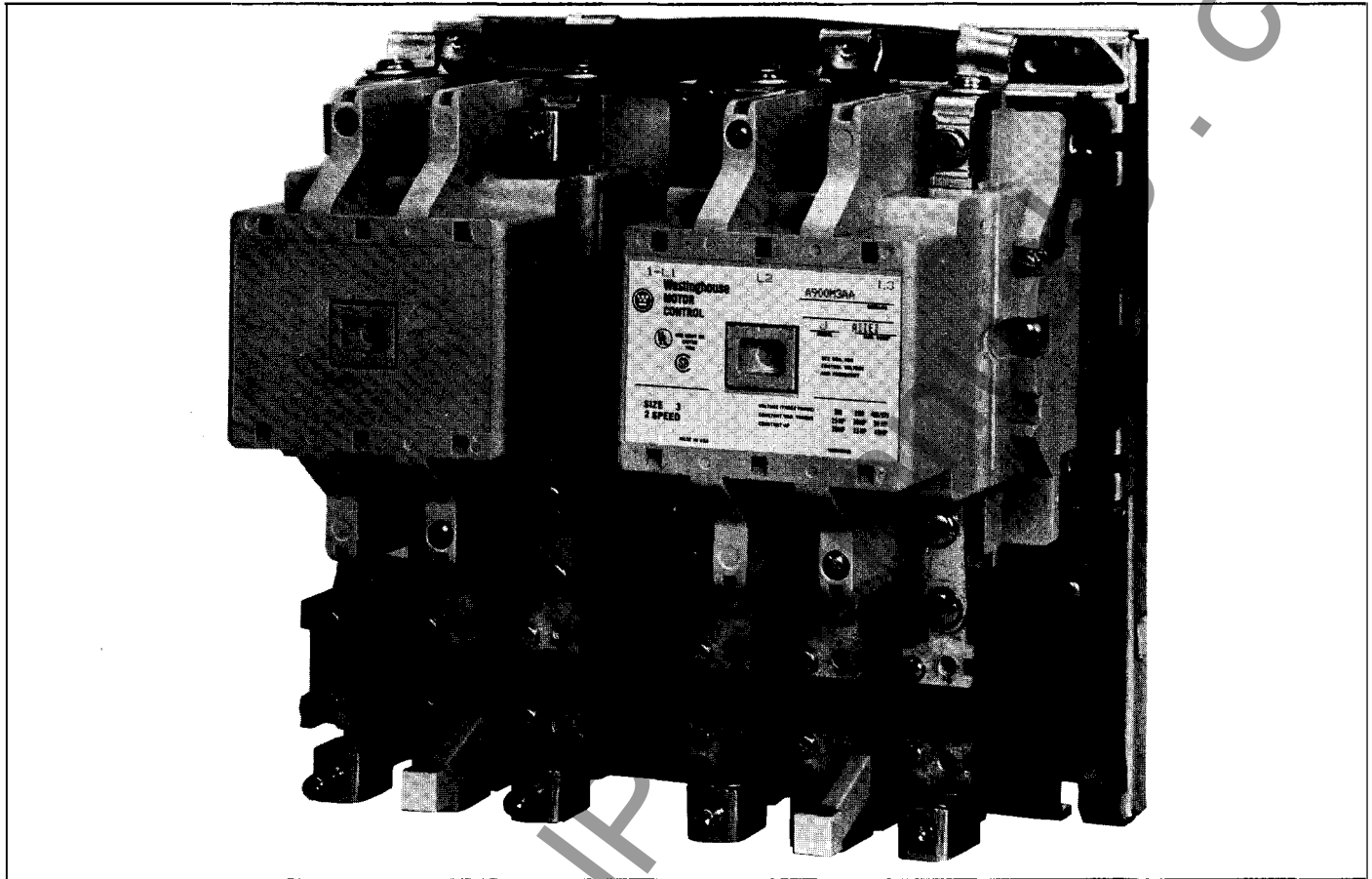

Fig. 1 Size 3 Two-Speed Controllers

## THE CONTROLLER

A900 two-speed motor controllers are available in the configurations listed in Table IV for use with three phase motors having either a reconnectable single winding (consequent pole) or two separate windings for a single voltage.

Two-speed motors with either one or two windings are available to provide one of three options at each of the two speeds, constant power (HP), constant torque, or torque proportional to speed (variable torque). One winding motors are either wye-wye or wye-delta connected and the controller required depends upon the motor option selected. Two winding motors may any combination of wye or delta connected and the controller required depends upon the number of delta connections involved. Any unused delta connection must be opened when the other connection is energized.

When the controllers are wired as shown in the appropriate connection diagram they will give protection against overload but not against short circuit currents, when wired and provided with overload relay (OLR) heaters as listed in heater application tables or when used with any means of inherent protection activated by motor temperature.

The controller should be protected against short circuits by providing branch circuit protection not to exceed the maximum protective device ratings listed in Table I for the smaller full load current.

This industrial type control is designed to be installed, operated, and maintained by adequately trained workmen. These instructions do not cover all details, variations, or combinations of the equipment, its storage, delivery, installation, check out, safe operation, or maintenance. Care must be exercised to comply with local, state, and national regulations, as well as safety practices, for this class of equipment.

TWO-SPEED CONTROLLER RATINGS				
FOR CONSTANT OR VARIABLE TORQUE MOTORS				
NEMA Size	THREE PHASE HORSEPOWER AT			
	200V	230V	380V	460/575V
3	25	30	50	50
4	40	50	75	100
FOR CONSTANT HORSEPOWER MOTORS				
NEMA Size	THREE PHASE HORSEPOWER AT			
	200V	230V	380V	460/575V
3	20	25	40	40
4	30	40	60	75

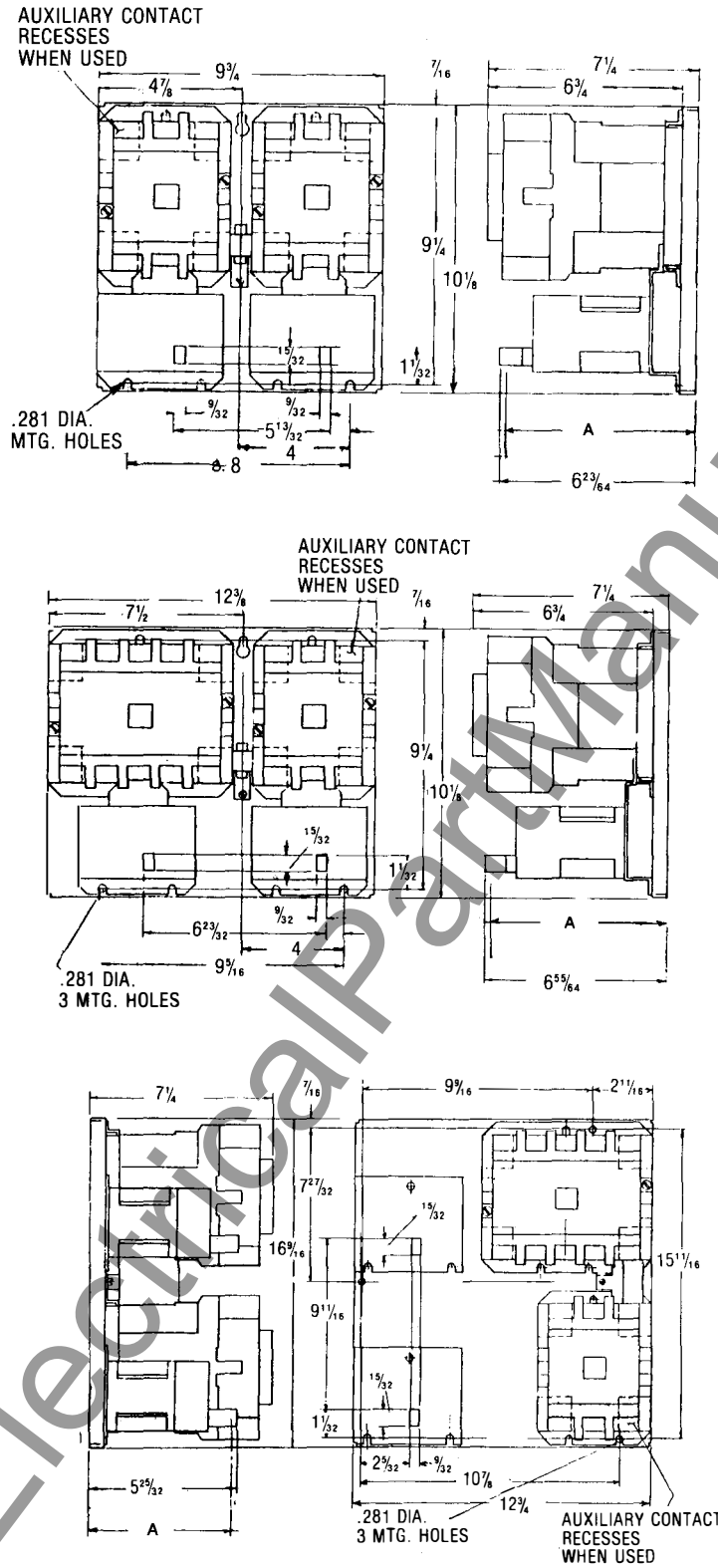

HORIZ. TYPE B RELAY, MAX. DIM. TO RESET	A = 6 39/64
VERT. TYPE B RELAY, MAX. DIM. TO RESET	A = 5 17/32
HORIZ. TYPE A RELAY, MAX. DIM. TO RESET	A = 6 43/64
HORIZ. TYPE A RELAY, AUTO. RESET	A = 6 7/16
VERT. TYPE A RELAY, MAX. DIM. TO RESET	A = 5 9/32
VERT. TYPE A RELAY, AUTO RESET	A = 5 31/64

Fig. 2 Dimension Drawings (Dim. in inches)

**AUXILIARY CONTACTS — L56 (RATED B600)**

Two L56's each with one normally open pole and one normally closed pole are supplied as the holding circuit auxiliary and electrical interlock between the two coil circuits. A maximum of four auxiliary units can be installed in the recesses of each contactor. These may be mounted with the terminals in line with the power poles or may be mounted with the terminals in a right angle relationship to the power poles. They mount by means of a spring clip which snaps into locations provided in the motor controller unit. To remove the L56 disengage the top spring clip, by pressing on the extended tab, and withdraw the unit.

**COIL**

The A900 motor controller is available with single or dual voltage coils. When equipped with single voltage coils, the controller is wired as shown in Figures 6 and 7. A connection diagram for a dual voltage coil is shown in Figure 3. When supplied with dual voltage coils, the motor controller is normally wired for the high voltage connection. The wiring may be changed to the low voltage connection by removing and reconnecting the jumpers as illustrated below.

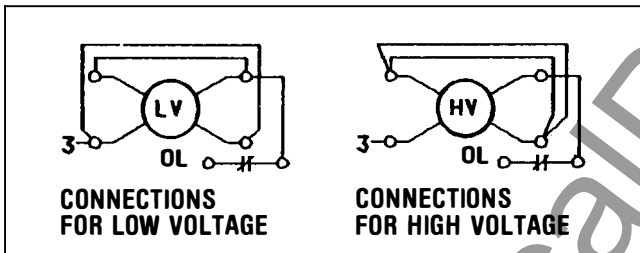

*Fig. 3 Dual Voltage Coil Connections*

**AC COIL DATA, SIZE 3 AND 4 (TYPICAL VALUES)**

Poles	Inrush VA	Sealed VA	Sealed Watts
3	625	50	18
5	825	75	27

**REPLACEMENT COIL: ORDER BY PART NUMBER, VOLTAGE, AND FREQUENCY**

SIZE 3 AND 4 AC OPERATING COILS			
Voltage	Freq.	Part Number	
		3 Pole	4-5 Pole
24	60	505C633G34	Not Available
120/110	60/50	505C633G01	505C635G01
208	60	505C633G02	505C635G02
240	60	505C633G12	505C635G12
277	60	505C633G14	505C635G15
380	50	505C633G07	505C635G07
480/440	60/50	505C633G13	505C635G13
600	60	505C633G05	505C635G05
120/240*	60/60	505C633G10	505C635G10
240/480*	60/60	505C633G03	505C635G03

\* Dual Voltage Coils. Use only on starters originally supplied with a dual voltage coil

**TYPE B OVERLOAD RELAY (See Figure 1)**

This A900 motor controller is usually equipped with Type B block type ambient compensated overload relays (with gray reset rod). The controller can also be supplied with non-ambient compensated overload relays (with red reset rod). Each relay is of the bimetal actuated type equipped with normally closed control contacts. An optional isolated normally open control circuit contact is available for field mounting. When the overload relay trips, a yellow dot will appear flush with the molded surface below the reset rod. Resetting the relay returns this indicator to its normal concealed position.

**TYPE A OVERLOAD RELAY (See Figure 4)**

The A900 motor controller can be equipped with Type A block type non-ambient compensated overload relays (unmarked and with red reset rod) or with block type temperature compensated overload relays (marked "ambient compensated" and with gray reset rod). Each relay is of the bimetal actuated type equipped with trip indicator, trip adjustment covering  $\pm 15\%$  of rating and a normally closed control contact. It may be operated with either hand or automatic reset.

Reset operation is determined by the position of the plate on the load side of the overload base. Position the reset plate away from the panel to set the "hand" position. Loosen the locking screw; move the reset plate toward the panel, and retighten the screw to set the "auto" position.

Automatic reset should not be used with 2-wire control circuits where automatic starting of the motor may be hazardous.

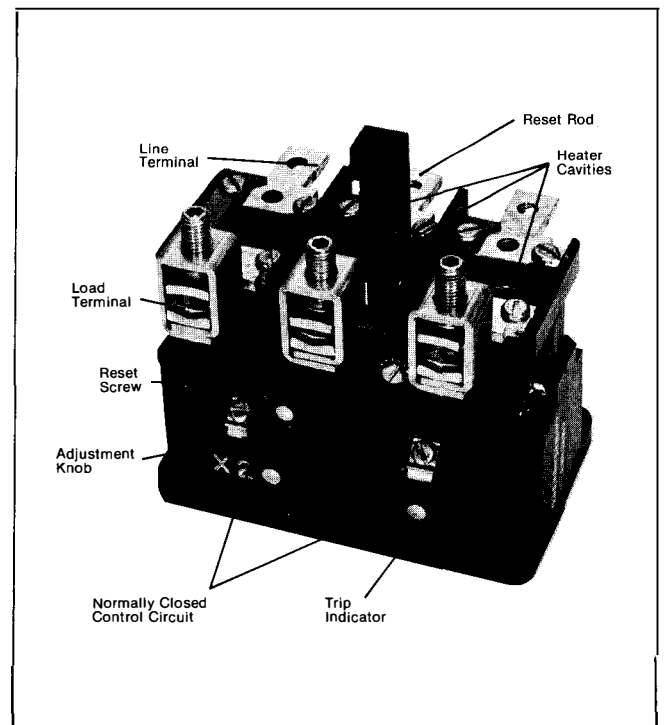

*Fig. 4 Type A Block Overload Relay*

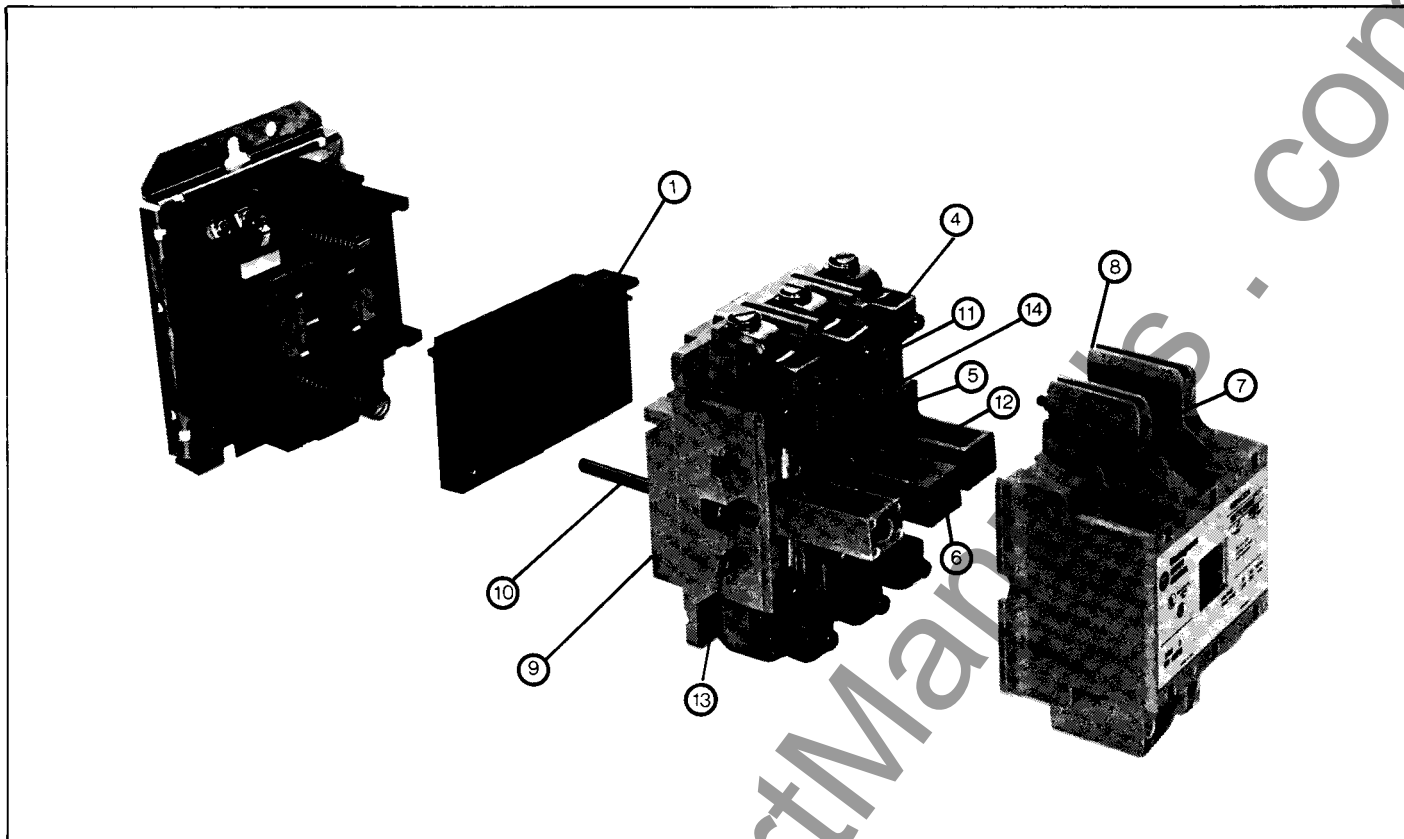

Fig. 8 Size 3 Contactor

**MAINTENANCE — First Turn Off Power**

**To Inspect Contacts**

Refer to Figure 8. Loosen the two arc box assembly screws (7) located immediately above and below the nameplate and remove the arc box (8). Contacts (5) are visible. Retighten the screws per Table V.

**To Replace Contacts**

After removing the arc box and with replacement contacts at hand, compress the overtravel spring (12) and remove the moving contact (5) from the crossbar (6). Remove the retaining screws (11) and lift out the stationary contact carriers (14).

To replace contacts, reverse the above procedure, making sure that stationary contacts are secure, (see Table V) moving contacts are free to move, overtravel springs are seated and the crossbar moves freely when the arc box is in position.

The silver cadmium oxide contact buttons need **NO** dressing or lubricant throughout their life.

**Important** — Replace all contacts and springs as a group to avoid misalignment.

**To Replace The Coil**

Refer to Figure 8. Loosen the assembly screws (10) located to the immediate left and right of the arc box. Remove connector straps to the overload relay. Pull the loosened upper base structure (9) forward. Pull the coil (1) from the upper base, plug in a new coil, replace the upper base structure and check the auxiliary contacts for secureness

when repositioning the upper base. Tighten the assembly screws and the connector straps screws referring to Table V.

**Magnet — Armature Assembly**

Self alignment and permanent air gap features of the magnet armature make replacement unnecessary. Mating pole face surfaces should be kept clean.

**Arc box must be in place when the controller interrupts a circuit.**

**TABLE V — RECOMMENDED DRIVING TORQUE**

Location (Qty.)	Driving Torque (lb.-in.)	Fig. 9 Item
Cover Screw (2)	18—21	7
Coil Wire Connector (2)	9—12	13
Stationary Contact Screw (6)	25—30	11
Main Power Connector (6)	75—100	4
Overload Relay Connecting Screws (3)	18—21	—
Overload Heater Fastening Screws (2 Per Pole)	18—21	—

**TABLE VI — RENEWAL PARTS**

Contact Kits Pole Combination and Size	Part Number
3 Pole Size 3	626B187G13
4 Pole Size 3	626B187G14
5 Pole Size 3	626B187G15
3 Pole Size 4	626B187G17
4 Pole Size 4	626B187G18
5 Pole Size 4	626B187G19

<b>L56 AUXILIARY CONTACTS</b>		
Contact Type	Catalog No.	
1 Normally Closed	L56E	
1 Normally Open	L56D	
2 Normally Closed	L56C	
2 Normally Open	L56B	
1 Normally Open and 1 Normally Closed	L56	
<b>CONTACT RATINGS (B600)</b>		
AC Volts	Make	Break
24-120	30A	3A
120-600	3600VA	360VA

<b>POWER CIRCUIT TERMINALS</b>	
NEMA Size	Wire Size
3	#8 - 2/0 AWG
4	#6 - 4/0 AWG
Wire with copper conductors only.	

**HEATERS**

Heaters are not included with the motor controller and must be ordered separately per the heater selection table and the information listed below. When installing heaters be sure that connecting surfaces are clean and heaters are attached securely to the relay in the proper location with the screws provided. The trip rating of a heater in a 40°C Ambient is 125% of the minimum full load current shown in Table I. This overload relay will trip in 20 seconds or less when 600 per cent of the trip rating is applied.

Heaters should be selected on the basis of the actual full load current and service factor as shown on the motor nameplate or in the manufacturer's published literature. When the service factor of the motor is 1.15 to 1.25, select heaters from the heater application table. If the service factor of the motor is 1.0, or there is no service factor shown, or a maximum of 115% protection is desired, select one size smaller heater than indicated. When motor and overload relay are in different ambients and when using non-compensated overload relays, select heaters from the table using adjusted motor currents as follows: decrease rated motor current 1% for each °C motor ambient exceeds controller ambient. Increase rated motor current 1% for each °C controller ambient exceeds motor ambient.

<b>OVERLOAD RELAY CONTROL CONTACT RATINGS</b>				
AC Volts	Normally Closed		Normally Open	
	Make	Break	Make	Break
<b>Type A</b>				
24-120	20A	2A	5A	5A
120-600	2400VA	240VA	600VA	60VA
<b>Type B</b>				
24-120	30A	3A	30A	3A
120-600	3600A	360VA	3600VA	360VA

<b>TABLE I — F SERIES HEATER SELECTION</b>			
For compensated OLR's in any size enclosure, and non-compensated OLR's in enclosures with volume not less than 5500 cu. in. Wire with 75°C wire.			
Code Marking	Full Load Current of Motor (Amperes) (40°C Ambient)	Max. Protect. Device (Amp)	Load Wire Size
FH76	27.9 — 30.6	110	#8
FH77	30.7 — 33.5	125	#8
FH78	33.6 — 37.5	150	#6
FH79	37.6 — 41.5	150	#6
FH80	41.6 — 46.3	175	#6
FH81	46.4 — 50	200	#6
FH82	51. — 55	200	#4
FH83	56 — 61	225	#4
FH84	62 — 66	250	#4
FH85	67 — 73	250	#3
FH86	74 — 78	250	#3
FH87	79 — 84	300	#2
FH88	85 — 92	350	#2
<b>ABOVE HEATERS FOR USE ON SIZE 3 (90 AMP MAX)</b>			
FH89	93 — 101	350	#00
FH90	102 — 110	350	#00
FH91	111 — 122	400	#000
FH92	123 — 129	400	#000
FH93	130 — 133	400	#0000
<b>ABOVE HEATERS FOR USE ON SIZE 4</b>			

**WARNING:** To provide continued protection against fire and shock hazard, the complete overload relay must be replaced if burnout of the current element occurs. See Table II.

<b>TABLE II — REPLACEMENT OVERLOAD RELAY</b>		
OVERLOAD RELAY	CATALOG NUMBER	
	SIZE 3	SIZE 4
Type B Non-ambient compensated	BN33A	BN43A
Type B Ambient Compensated	BA33A	BA43A
Type A Non-ambient compensated	AN33A	AN43A
Type A Ambient Compensated	AA33A	AA43A

<b>TABLE III — ACCESSORIES</b>		
Alarm Circuit Contact for Type B Overload Relay Rated B600 (1 normally open pole)		<b>Cat. No.</b> B3NO-4
Fuse Block Kits — Meet requirements of NEC concerning common control fusing.		
<b>Order</b>	<b>Qty.</b>	<b>Description</b>
<b>Cat. No.</b>		
F56	2	Contact mounted Fuse Holder for 1 600 volt Bussman KTK Fuse
FKR	1	Panel mounted Fuse Holder for 2 Class CC (Bussman KTKR) Fuses*
*Use when available fault current exceeds 10,000 amperes		
<b>Order Fuses Separately By Ampere Rating.</b>		
<b>Controller Size</b> 3 and 4	<b>Minimum Wire Size in Control Circuit</b> #16 AWG	<b>Suggested Fuse Size†</b> 10 AMP
†When using a control transformer, select fuse size per the National Electrical Code.		

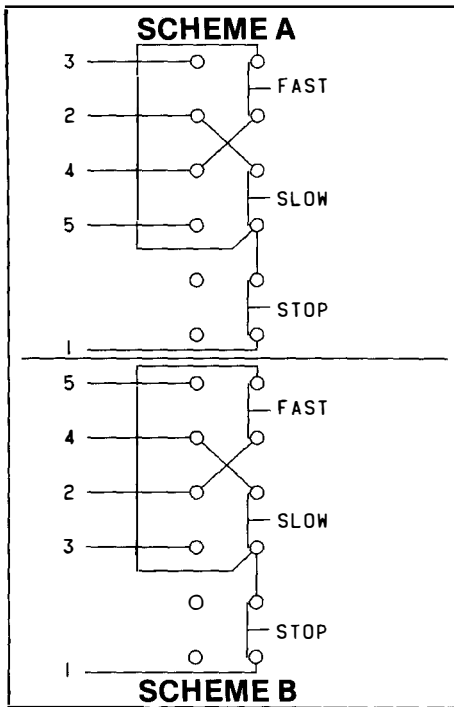

Fig. 5 Control Station Diagram

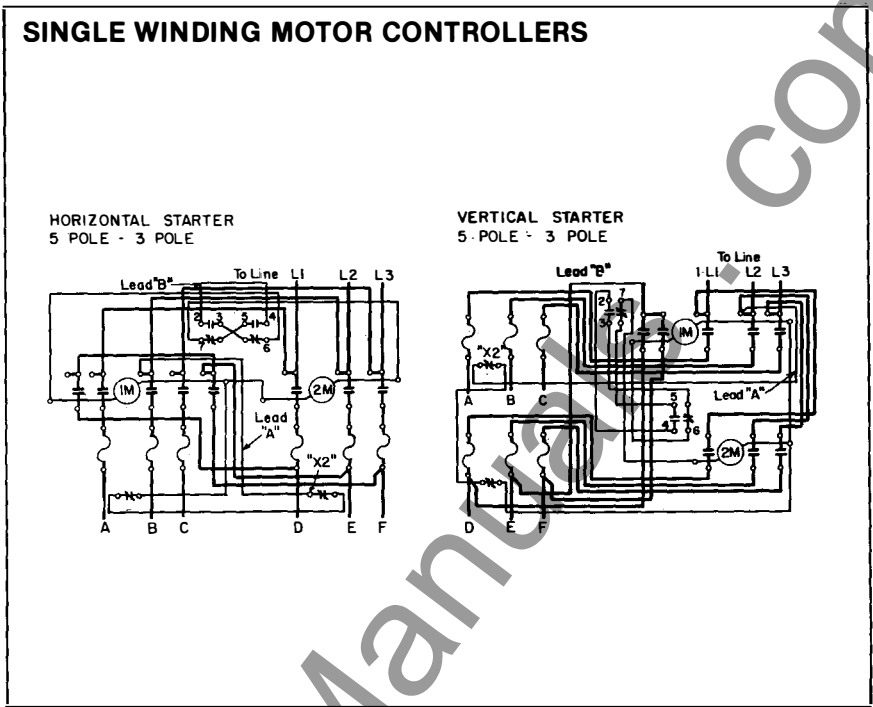

Fig. 6 Connection Diagram for Consequent Pole Motors

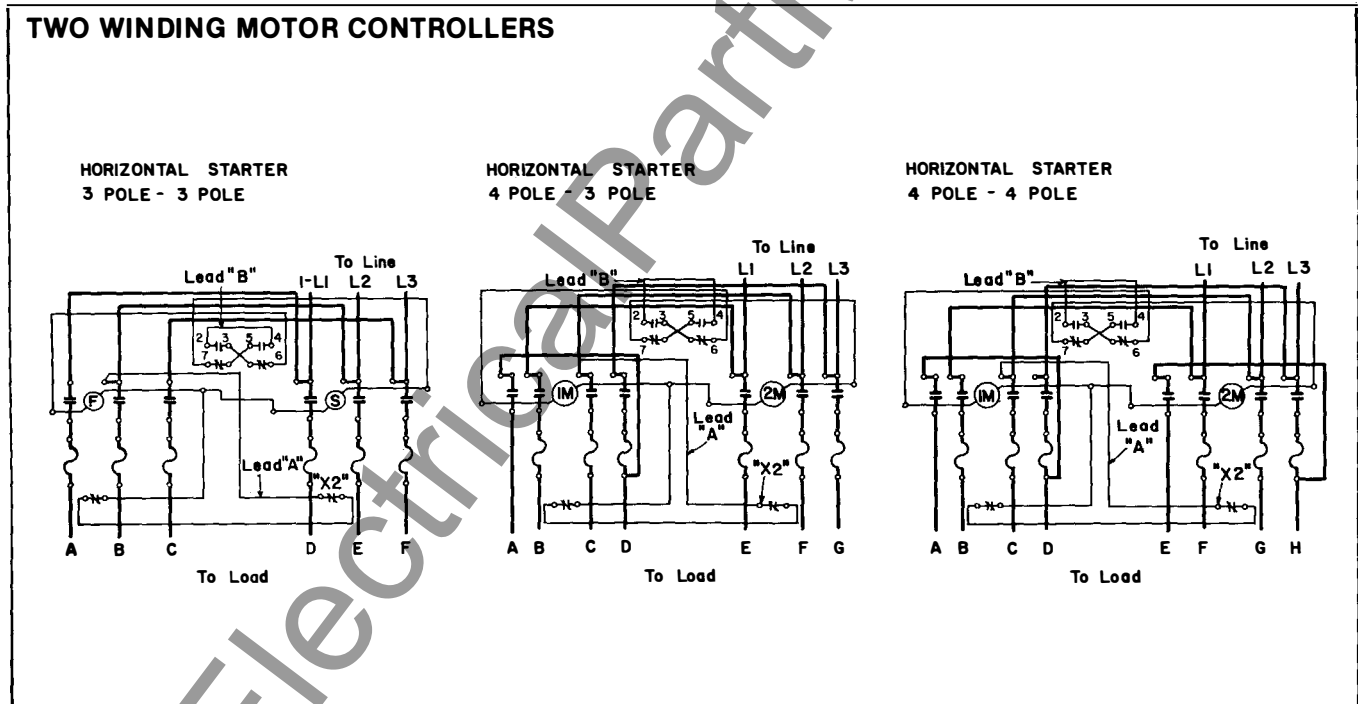

Fig. 7 Connection Diagram for Separate Winding Motors

TABLE IV — MOTOR-TO-CONTROLLER CONNECTIONS					
Motor Type		Low Speed (Slow) Connections	High Speed (Fast) Connections	Contactor Poles	Control Sta. (Fig. 5)
One Winding Motor	constant torque	T1-D, T2-E, T3-F, (T7-F)	T4-B, T5-C, T6-A	5x3	Scheme A
	variable torque	T1-D, T2-E, T3-F	T4-B, T5-C, T6-A	5x3	Scheme A
	constant power	T1-A, T2-B, T3-C	T4-E, T5-F, T6-D, (T7-F)	5x3	Scheme B
Two Winding Motor	wye-wye	T1-D, T2-E, T3-F	T11-A, T12-B, T13-C	3x3	Scheme A
	wye-delta	T1-E, T2-F, T3-G	T11-B, T12-C, T13-D, T17-A	4x3	Scheme A
	delta-wye	T1-B, T2-C, T3-D, T7-A	T11-E, T12-F, T13-G	4x3	Scheme B
	delta-delta	T1-B, T2-C, T3-D, T7-A	T11-E, T12-F, T13-G, T17-H	4x4	Scheme B