

IQ-2000™

MOTOR COMMAND SYSTEM USER'S MANUAL

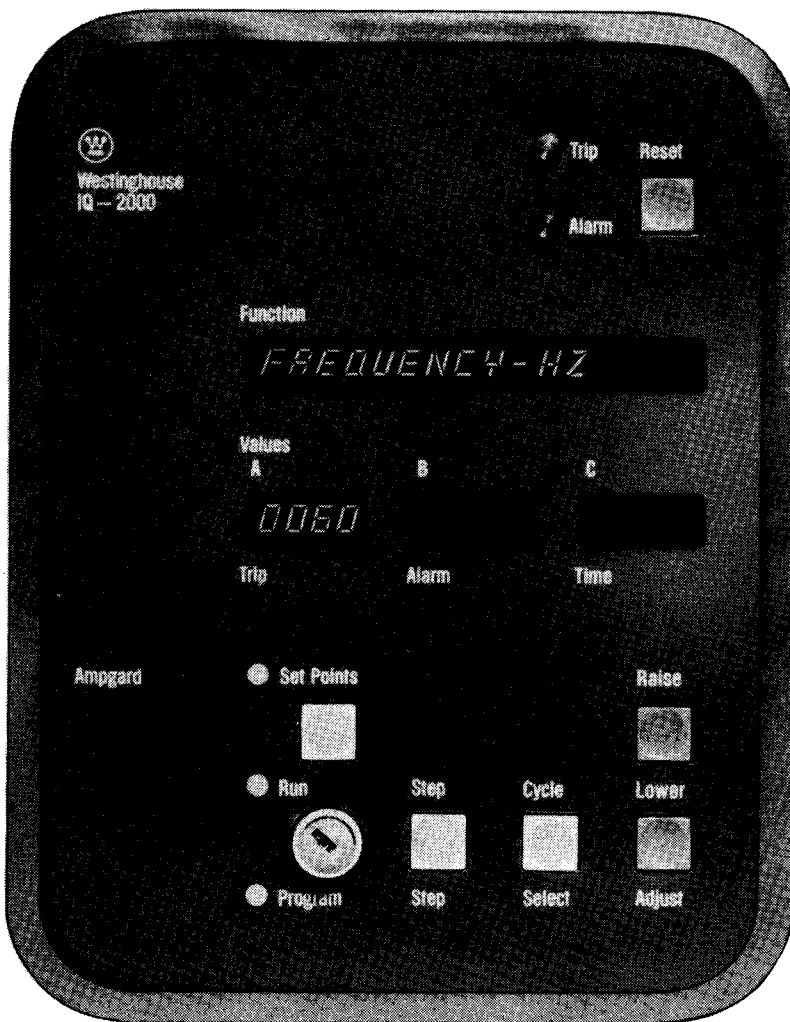

CONTROL DIVISION

Copyright

©

1983

Westinghouse Electric Corporation

Control Division

Asheville, NC 28813



First Printing: May, 1983

NOTE

All possible contingencies which may arise during installation, operation, or maintenance, and all details and variations of this equipment do not purport to be covered by these instructions. If further information is desired by purchaser regarding his particular installation, operation or maintenance of his equipment, the local Westinghouse Electric Corporation representative should be contacted.

Effective August, 1982

TABLE OF CONTENTS

Sec./Par.	Title	Page	Sec./Par.	Title	Page
1	Description	5	5.1.5.1	Negative Sequence Currents	29
1.0	General	5	5.1.5.2	Positive Sequence Currents	29
1.1	Features and Options	6	5.2	Motor Control	29
1.2	Specifications	7	5.2.1	Motor Starting	29
1.3	Hardware Familiarization	7	5.2.2	Long Acceleration Starting	32
1.4	Use of Manual	7	5.2.3	Motor Stopping	32
1.5	Level of Repair	7	5.3	AC Line Interruptions	34
2	Functional Theory	9	5.4	Control Signal Wiring	34
2.0	General	9	5.4.1	Discrete Inputs	34
2.1	Sensing Inputs	9	5.4.2	Output Contacts	36
2.1.1	Motor Current Sensing	9	5.5	Wiring Considerations	37
2.1.2	RTD Module	9	5.5.1	RTD Wiring	38
2.1.3	Control Lines	9	5.5.2	Grounding	38
2.2	Protective Functions	9	5.5.3	Wire Routing	38
2.3	Motor Control Functions	11	5.6	Environmental Considerations	39
2.4	Metering Functions	11	6	Setpoint Value Considerations	40
3	Installation	12	6.0	General	40
3.0	General	12	6.1	Winding Temperature	40
3.1	Ampgard Schematic	12	6.2	Motor Bearing Temperature	41
3.2	Wiring Plan Drawings	12	6.3	Load Bearing Temperature	41
3.3	Wiring Guidelines	12	6.4	Ground Fault	41
3.3.1	Wire Routing	12	6.5	Instantaneous Overcurrent	41
3.3.2	Types of Wire	12	6.6	Locked Rotor Current	41
3.3.3	Grounding	14	6.7	Long Acceleration	41
3.4	Wiring Checklist	16	6.8	Jam	44
4	Startup	18	6.9	Underload Start	44
4.0	General	18	6.10	Underload Run	44
4.1	Operator Panel Description	18	6.11	Ultimate Trip	45
4.1.1	RUN/PROGRAM Keyswitch	19	6.12	Overvoltage	45
4.1.2	FUNCTION Window	19	6.13	Undervoltage	45
4.1.3	VALUES Windows	19	6.14	Pre-start Timer	45
4.1.4	ADJUST Pushbuttons	19	6.15	Pre-run Timer	46
4.1.5	STEP Pushbutton	19	6.16	Pre-stop Timer	46
4.1.6	CYCLE/SELECT Pushbutton	20	6.17	Incomplete Sequence	48
4.1.7	RUN, PROGRAM LEDs	21	6.18	Anti-backspin	48
4.1.8	SET POINTS Pushbutton, LED	21	6.19	Anti-recycle, Min	48
4.1.9	TRIP, ALARM LEDs	21	6.20	Time Undervoltage	49
4.1.10	RESET Pushbutton	21	6.21	Post-start Timer	49
4.2	Initial Programming and Sequencing Checks	21	6.22	Post-stop Timer	49
4.2.1	Power Off	21	6.23	Start Counts/Hours	50
4.2.2	Control Power Only	22	6.24	Open/Unbalance Phase	50
4.3	Entering Setpoints	22	6.25	Full-load Current	50
4.3.1	Setpoint Record Sheet	22	6.26	Current Transformer Ratio	51
4.3.2	Value Entry	23	6.27	Potential Transformer Ratio	51
4.4	Initial Motor Startup	24	6.28	Starter Class	52
4.5	Initial Main Power-on	24	7	Monitoring and Troubleshooting	54
5	Application Considerations	25	7.0	General	54
5.0	General	25	7.1	Panel Operations	54
5.1	Motor Protection	25	7.1.1	Normal Operational Reporting	54
5.1.1	Overload Protection without RTDs	25	7.1.2	Reviewing Setpoints	54
5.1.2	Overload Protection with RTDs	25	7.1.3	Monitoring Characteristics	55
5.1.3	Protection Curve	26	7.2	Malfunction Isolation	55
5.1.3.1	Instantaneous Overcurrent	28	7.2.1	Panel Inoperative	55
5.1.3.2	Allowable Locked-Rotor Current, Time	28	7.2.2	Panel Operating	55
5.1.3.3	Ultimate Trip	28	7.2.2.1	Alarm Conditions	57
5.1.3.4	Underload Function	28	7.2.2.2	Trip Conditions	58
5.1.3.5	Jam Function	29	8	Unit Replacement	61
5.1.3.6	Temperature Effects	29	8.0	General	61
5.1.4	Typical Motor Protection Curves	29	8.1	Processor Module Replacement	61
5.1.5	Motor Current	29	8.2	RTD Module Replacement	62
			8.3	Terminal Identification	62

LIST OF FIGURES

Figure	Title	Page	Figure	Title	Page
1.1	IQ-2000 Installed in Ampgard Enclosure	5	5.5	Motor Protection Curve (with RTDs)	31
1.2	Main Feature Locations	8	5.6	Motor Start Cycle Events Diagram	33
2.1	Functional Block	10	5.7	Motor Stop Cycle Events Chart	35
2.2	AC Line Phases	11	5.8	AC Interrupt Events Flow Chart	36
3.1	Ampgard Schematic	13	5.9	RTD Wiring	39
3.2	Wiring to Draw-Out Panel	14	6.1	Long Acceleration Events Diagram	44
3.3	RTD Wiring (3-lead type)	15	6.2	Pre-start Events Diagram	46
3.4	Two-Lead RTD Wiring	16	6.3	Pre-run Events Diagram	47
3.5	Typical Grounding Plan	16	6.4	Pre-stop Events Diagram	47
3.6	Jumper and Field Wiring	17	6.5	Incomplete Sequence Events Diagram	48
3.7	Ampgard Internal View	18	6.6	Time Undervoltage Events Diagram	49
4.1	Operator Panel with Manual References	20	6.7	Post-start Events Diagram	50
4.2	Setpoint Record Sheet	22	6.8	Post-stop Events Diagram	51
4.3	Winding Temperature Displays	23	6.9	Interposing Relay Wiring	52
5.1	Rotor Temperature Tracking	26	7.1	Display/Run Sequence Relations	54
5.2	Motor Protection Curve (without RTDs)	27	7.2	Reviewing Message	55
5.3	Underload and Jam Protection	28	7.3	Processor and RTD Module	57
5.4	Motor Protection Curve (without RTDs)	30	8.1	Processor and RTD Module	61
			8.2	Ribbon Cable Connector	62
			8.3	Terminal Designations	63

LIST OF TABLES

Table	Title	Page	Table	Title	Page
1.A	IQ-2000 Feature and Benefits	6	6.B	Setpoint Record Sheet	42
1.B	Specifications	7	6.C	Starter Classes	52
5.A	Input Circuit Characteristics	36	6.D	Relay C1 thru C4 Functions	53
5.B	Input Terminal Description	37	7.A	Monitoring Operation	56
5.C	Momentary and Maintained Input Terminals	38	7.B	Troubleshooting: Operator Panel Inoperative	57
5.D	Control Function Relay Contacts	39	7.C	Alarm Conditions	58
6.A	Setpoint Function Index	40	7.D	Trip Conditions	59

Section 1

DESCRIPTION

1.0 General — The IQ-2000™ is a microprocessor-controlled, motor command system that is made available in a single, integrated package. It is designed for use with the Ampgard® Motor Control Assembly, and other types of starters. (See Figure 1.1.)

With respect to motors, the IQ-2000 has 3 primary functions:

- Protection
- Monitoring
- Control

A unique **protection** algorithm utilizes 3-phase motor current information and stator winding temperature data to protect both the stator and rotor from damage due to thermal overloads. The protection scheme utilizes the concept of positive and negative sequence currents, coupled with digital thermal modeling, to predict rotor temperature and remove motor power before the thermal limits are exceeded.

The **monitoring** features include extensive instrumentation, including current, voltage, watts, frequency, power factor, elapsed time, and number of operations.

The **control** feature replaces the discrete relay logic for pre-start, post-start, pre-stop and post-stop timing functions and various enabling signals. Now programmable logic, under the control of the microprocessor, can perform these operations. This permits a single IQ-2000 to be easily programmed for a simple across-the-line starter or a complex starter such as a reduced-voltage start, reversing style, by means of simple pushbutton "user friendly" programming techniques.

Also included are numerous adjustable alarm and trip parameters. Extensive self-diagnostics are provided, including contactor report-back status signals which enhance system reliability. In instances when motor conditions exceed the programmed setpoint values, an alarm and/or trip condition is automatically initiated. The alarm condition causes a red LED on the Operator Panel to light. (See Table

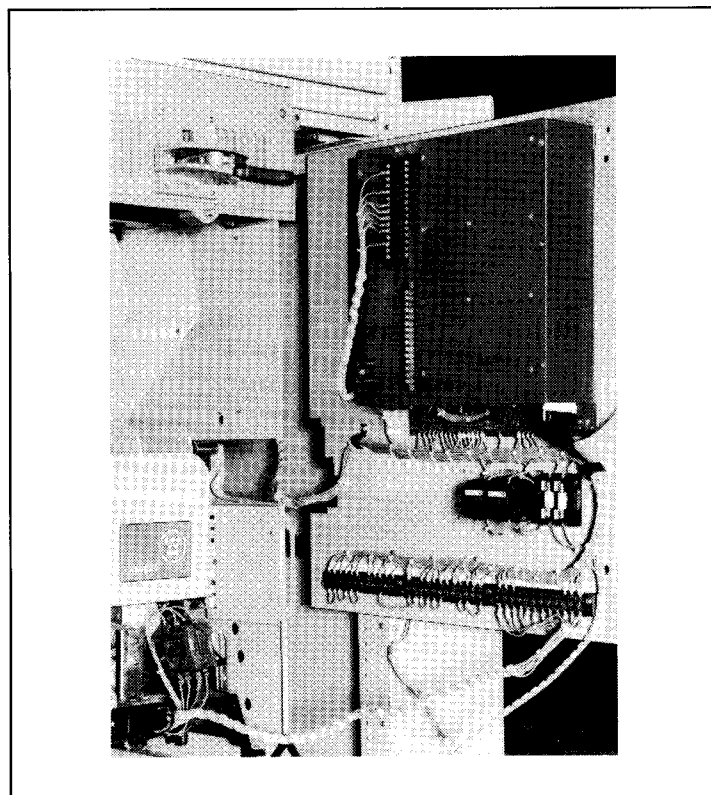

Figure 1.1 — IQ-2000 Installed in Ampgard Enclosure

7.C.) It also closes the internal Alarm Relay. Contacts from it are user-accessible for connection with external signaling devices, if desired.

The trip condition causes the main contactor(s) to open, thereby stopping the motor. (See Table 7.D.)

The 3 primary functions are actually composed of 28 separate functions, all of which are supplied as standard software and resident in permanent memory. A complete listing of these is given in Table 6.A. More detailed explanations are contained in Table 6.B. These functions were chosen to cover most features required by a wide variety of motor starters.

In instances where a particular function is not required by the application, it can be easily "programmed out," yet it remains passively resident in the software should it be required later.

Since the IQ-2000 is a single-model product with very few options, individualizing for an application is performed in the field by the user/OEM by means of a simplified programming technique. Users enter the setpoint values for each function through the Operator Panel. (See the title page of this manual.) A simple grouping of pushbuttons allows the setpoints to be quickly entered. (There is no need to learn a specialized language.) An interactive alphanumeric display screen shows the entries and clearly indicates the function being specified. Once the fixed "menu" of functions is worked through, the setpoints are "permanently" loaded into the IQ-2000. They remain stored through power outages, or until new programming entries change the values.

1.1 Features and Options – A list of features and benefits is given in Table 1.A. Since the IQ-2000 is a standardized

Table 1.A
IQ-2000 FEATURES AND BENEFITS

Feature	Benefit
<ul style="list-style-type: none"> ● Micro-processor based control ● All 28 setpoint functions available in all units ● Undesired functions are simply programmed out ● Single model unit ● Nonvolatile memory ● Man-readable programming ● Setpoints easily determined ● Simplified Operator Panel ● Display window shows a number of diagnostic conditions ● Ease of startup ● Auxiliary contacts ● Keylock mode switch 	<ul style="list-style-type: none"> ● Reliable service without need for numerous discrete components ● Allows for wide-spread standardization of control types regardless of parameters or starter types ● No extra costs for unwanted features ● In-field removal or reactivation of functions ● Low inventory of spares possible ● Quick, inexpensive interchangeability during maintenance ● No lost programs nor special back-up batteries ● No special language to be learned ● Setpoint values easily written with everyday numbers ● Motor manufacturer's data and a knowledge of the application are sufficient ● No elaborate, complex keyboard ● Functions and diagnostic messages displayed in man-readable format ● Install and maintain without extra and special test equipment ● Low time-to-assemble factor ● Fast program entry ● Allow for additional process operations beyond the basic motor starting/stopping ● Allow for external warning devices when approaching setpoint thresholds ● Provides protection against program tampering while allowing the monitoring of programmed setpoints ● Minimizes shut-downs for noncritical reasons

package, there are very few options. Those currently available are:

- **RTD Module**, which is required if resistance temperature devices are used to monitor motor and load or motor bearing temperatures.
- **Ground Fault Transformer**, which provides input current signals. (Its ratio is always 50:5.)
- **Potential Transformers**, which provide incoming AC line phase and level information.
- **RS-232 Computer Data Port**, explained in a separate instruction leaflet.

1.2 Specifications — The specifications for the IQ-2000 motor command system are listed in Table 1.B.

Table 1.B
SPECIFICATIONS

Input Power Requirements
120 VAC (±15%)
Frequency
50/60 Hz 1
Power Consumption
Processor: 60 VA RTD Option: 6 VA
Current Transformer "Burden"
0.001 VA
Operating Temperature
-20° to 70°C 2 (-4° to 158°F)
Storage Temperature
-20° to +85°C (-4° to +185°F)
Humidity
0 to 95% R.H. noncondensing
Fuses
Processor: F2 - 4 amp, 250 V slo-blo RTD Option: F1 - 1 amp, 250 V normal-blo
Enclosure
NEMA Type 1
1 Factory set; specify with order.
2 The operating temperature range of the external face of Operator Panel is limited to 0° to 55°C (32° to 131°F). This is not subject to the internal temperature rise of the starter.

1.3 Hardware Familiarization — The purpose of this Paragraph is to familiarize the user with the main hardware features of the IQ-2000. A complete description of the Operator Panel and the functions of each pushbutton is given in Chapter 4.

An IQ-2000 is factory-shipped mounted in the low-voltage compartment of the Ampgard enclosure, as is shown in Figure 1.2. Callouts in the figure are keyed to explanations included here.

1. NEMA Type 1 enclosure
2. Operator Panel (rear view)
3. 37-wire ribbon cable connecting Operator Panel and Processor Unit
4. Processor Unit (under metal cover)
5. RTD Module (optional) 10 Ohm, 100 Ohm, 120 Ohm
6. TB-R
7. TB-A
8. TB-B
9. TB-C
10. TB-D
11. External pushbuttons (if used)
12. Processor fuse F2: ACG3, 4 amp, 250 V, slo-blo (Littelfuse 313 004, or equiv.)
13. RTD Module fuse F1: ACG3, 1 amp, 250 V, normal-blo (Littelfuse 312 001, or equiv.)

1.4 Use of Manual — This manual is designed for use during installation and troubleshooting and, if necessary, unit replacement. It also has information of specific importance for the user application engineer who is planning the motor control system and who is determining the setpoint values for the IQ-2000's functions.

The manual is broad enough in scope to form the basis of new employee familiarization, refresher training sessions, and on-going maintenance.

It is strongly advised that the application engineer carefully read Chapters 2 thru 7 **before** beginning the application's Wiring Plan Drawings and Setpoint Record Sheet. Installation teams should carefully read all of Chapter 4 **before** starting final installation. Maintenance personnel should be familiar with Chapters 7 and 8 before attempting to service the IQ-2000.

1.5 Level of Repair — This manual is written with the assumption that only unit-level troubleshooting will be performed. If the cause of a malfunction is traced to an IQ-2000, the unit should be replaced with a spare. It should then be returned to Westinghouse for factory repairs.

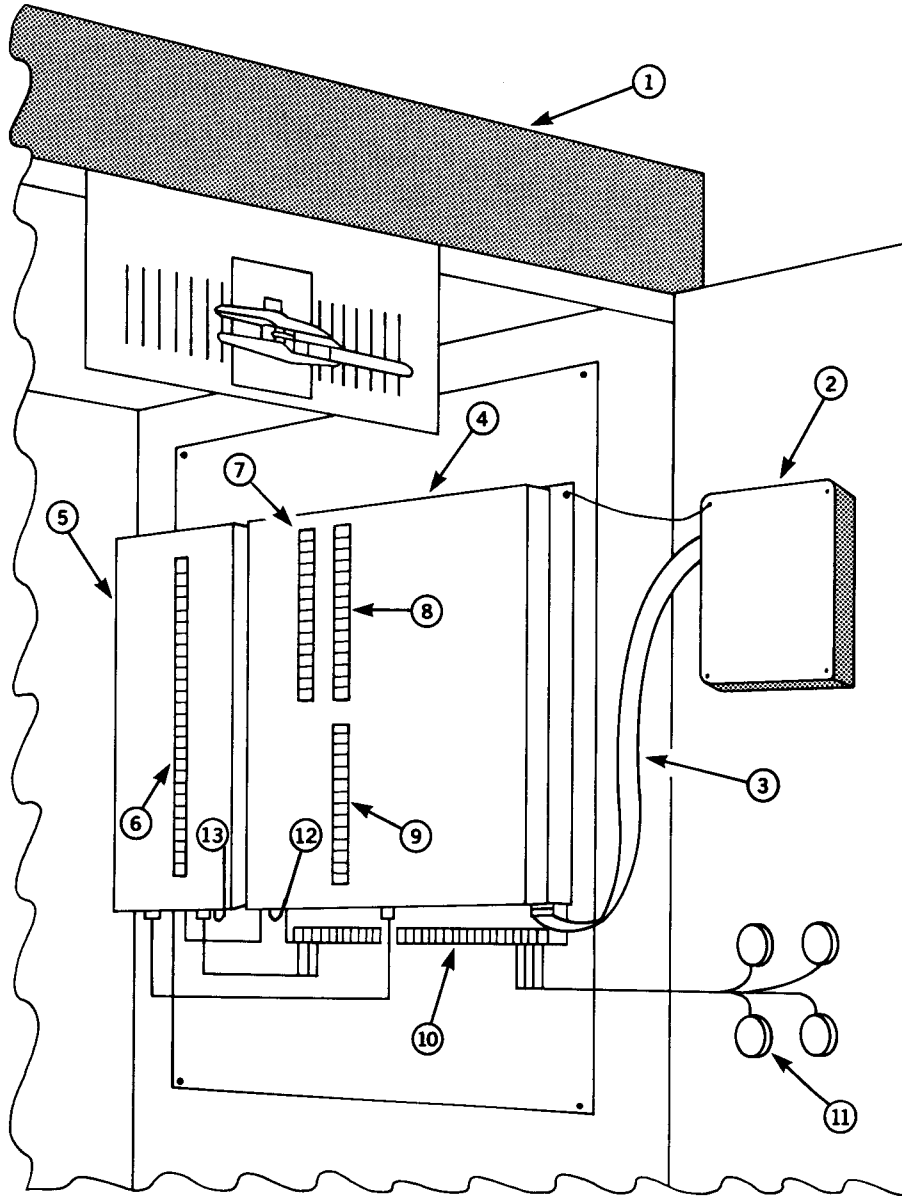

Legend:

- | | | |
|--|--------------------------|------------------------------------|
| 1. NEMA Type 1 enclosure | 5. RTD Module (optional) | 10. TB-D |
| 2. Operator Panel (rear view) | 6. TB-R | 11. External pushbuttons (if used) |
| 3. 37-wire ribbon cable connecting Operator Panel and Processor unit | 7. TB-A | 12. Processor fuse F2 |
| 4. Processor Unit (under metal cover) | 8. TB-B | 13. RTD Module fuse F1 |
| | 9. TB-C | |

Figure 1.2 – Main Feature Locations

Section 2

FUNCTIONAL THEORY

2.0 General — The IQ-2000 is a microprocessor-based system that controls from 1 to 4 contactors associated with a motor starter. This Chapter describes how the hardware and software function together to control, monitor and protect the motor.

The description is divided into the following areas:

- Sensing inputs (Par. 2.1)
- Protective functions (Par. 2.2)
- Motor control functions (Par. 2.3)
- Metering functions (Par. 2.4)

2.1 Sensing Inputs — The IQ-2000 receives information about motor current, line voltage and ground fault current as well as control inputs such as motor starting and stopping commands. (See Figure 2.1.) Optionally, RTD inputs supply temperature data. The motor current and control inputs are described in more detail in the following paragraphs.

2.1.1 Motor Current Sensing — A separate current transformer is used for each of the 3 phases of the AC line. Each phase is sampled every 120 degrees so that a total of 9 current readings are obtained in each 360° line cycle. The monitoring is delayed 10 degrees each cycle so that all portions of the AC motor current wave will be monitored in 12 cycles (12 x 10 = 120). While sampling the AC line, both the positive (I_1) and negative (I_2) components of the motor current are calculated as follows:

$$I_1 = \frac{I_A + (I_B + 120^\circ) + (I_C + 240^\circ)}{3}$$

$$I_2 = \frac{I_A + (I_B - 120^\circ) + (I_C - 240^\circ)}{3}$$

Figure 2.2(a) shows the phase relationships among I_A , I_B , and I_C when they are "in-phase" with equal magnitudes. At this time they are "balanced," or not shifted from their 0, 120, 240 degree relationship. Figure 2.2(b) shows an "unbalanced," or out-of-phase condition. Note: the phases are considered "in phase" when I_2 is equal to 0.

The calculated values I_1 and I_2 are used by the protective functions for rotor and stator temperature protection. The instantaneous overcurrent trips when the actual current exceeds the predetermined level. A 1-cycle delay prevents nuisance tripping.

2.1.2 RTD Module — The optional RTD Module supplies information on the winding temperature from up to 6

RTDs embedded in the stator windings of the motor. In addition, RTDs associated with the motor bearings and load bearings can also be monitored. The motor RTDs are used to supply information for both the winding and rotor temperature protection function and the temperature monitoring function.

2.1.3 Control Lines — Monitoring of the signal lines from the machine or process associated with the starter is performed by the input monitoring area of the Processor Module. These lines include the report-back signals as well as the start and stop command lines. These lines are used by the motor control area to enable and disable both the main contactor(s) and the auxiliary relays.

2.2 Protective Functions — Protective functions utilize motor conditions such as current and temperature on an on-going basis and first initiate an alarm condition, where appropriate, and finally a trip condition. (See Figure 2.1.) These conditions perform the following functions:

- Alarm condition energizes the Alarm Relay (not shown). Its contacts are used external to the IQ-2000 for control or reporting purposes.
- Trip condition removes the power from the motor and actuates a Trip Relay (not shown). The contacts of the Relay are used external to the IQ-2000 for controlling or reporting purposes.

When a trip condition occurs, the control stores the metering functions such as motor current, temperature, etc. This "picture" is maintained for use by maintenance personnel until the RESET pushbutton is depressed.

The fault monitoring can be divided into the following groups or functions:

- **Load associated protection.** The value of the motor current is used to detect the instantaneous overcurrent, jam and underload setpoint functions. Information from the load bearing RTDs is compared with the setpoint values to initiate an alarm and/or a trip condition. (Note: all the setpoint functions are described in detail in Chapter 6.)
- **Rotor temperature protection.** Utilizes the motor current (I_1) and the negative sequence current (I_2) to calculate and maintain a record of the rotor's temperature. This is more fully described in Paragraph 5.1. In addition, temperature data from the motor

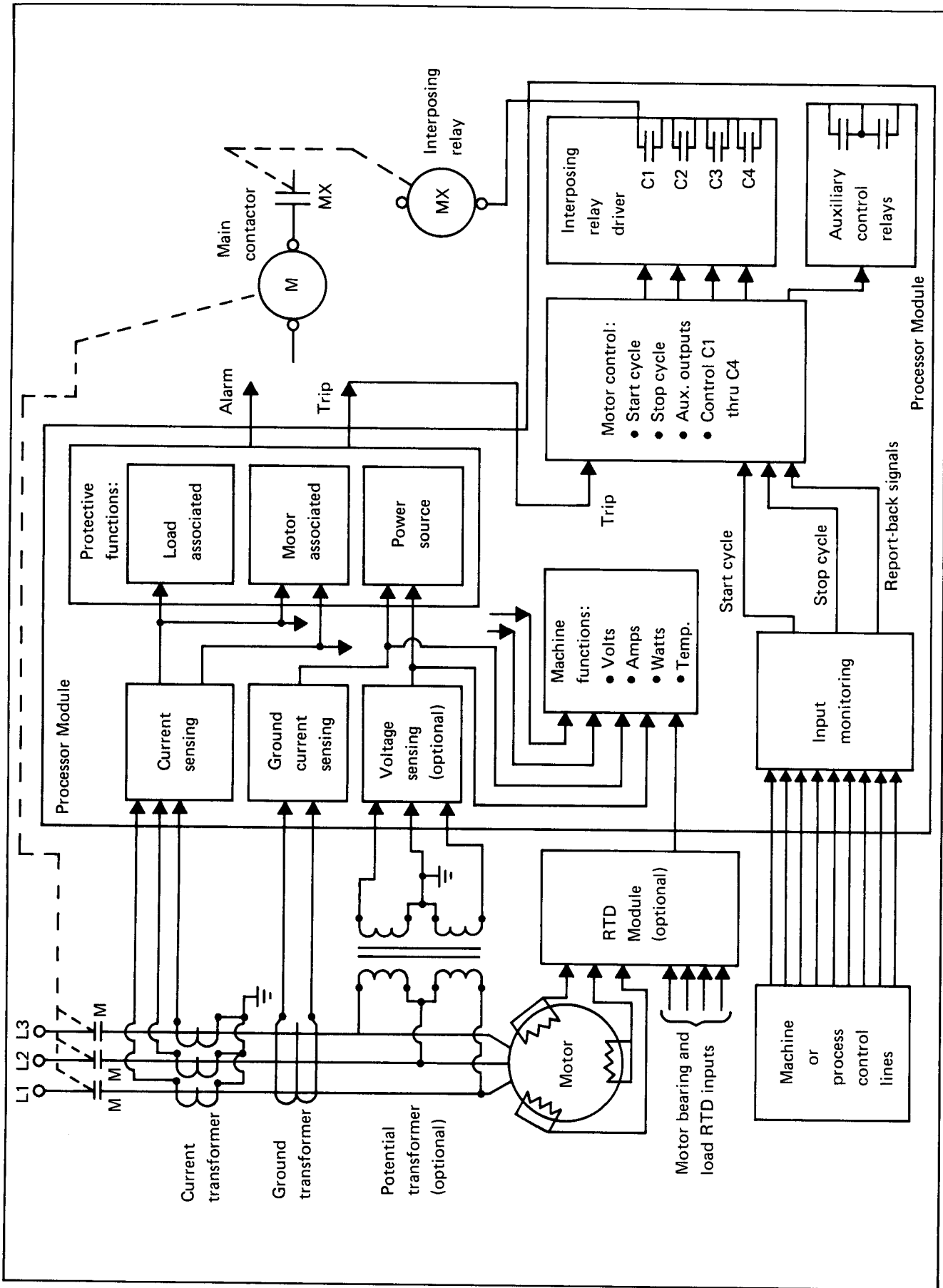

Figure 2.1 – Functional Block

winding and bearing RTDs is compared with program setpoints to initiate alarm and/or trip conditions.

2.3 Motor Control Functions – The motor control function receives the “command” inputs to start and stop the motor, and coordinates the energizing and de-energizing of the contactor(s) and auxiliary control relays.

2.4 Metering Functions – The control calculates and displays the instantaneous and accumulated values obtained by monitoring characteristics such as motor current, ground current, RTD temperature values, etc. (Chapter 7 describes the monitoring capabilities of the control in detail.)

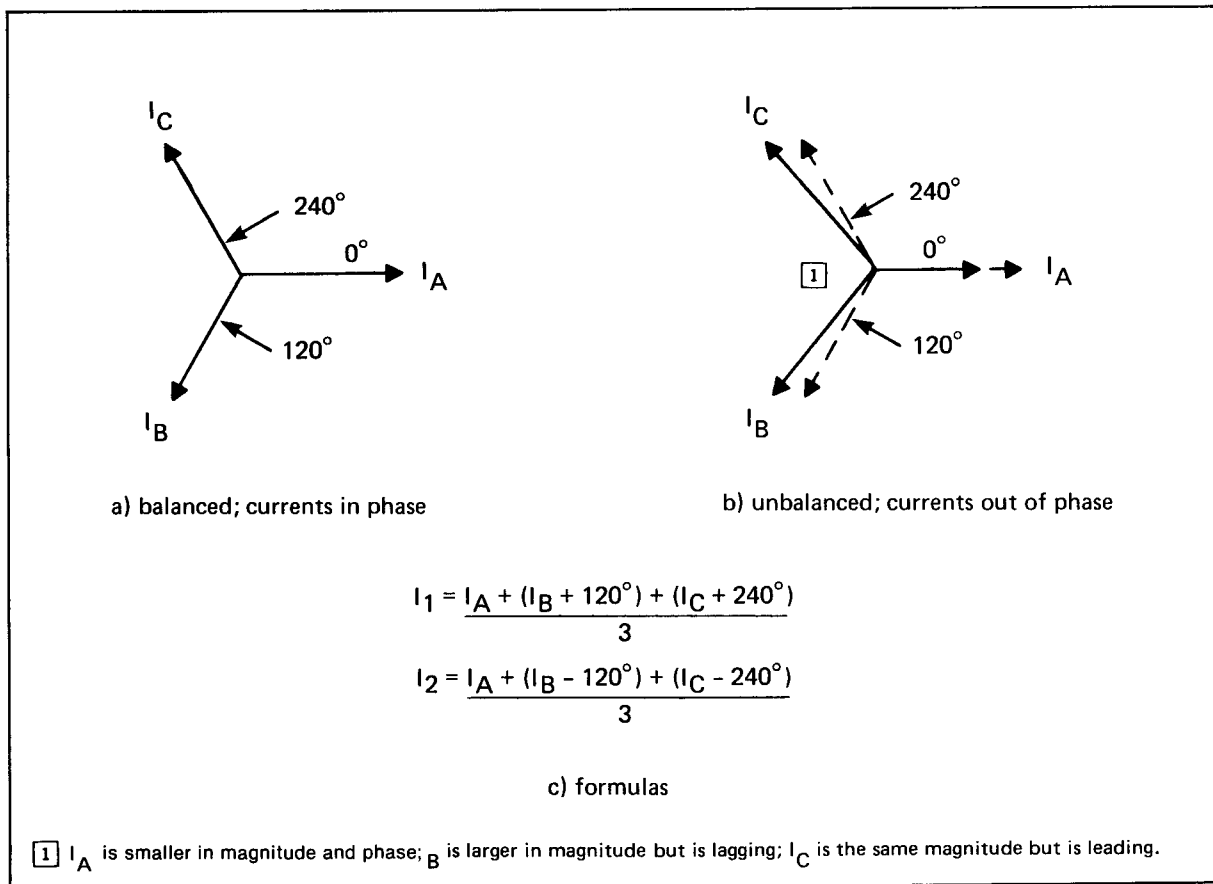

Figure 2.2 – AC Line Phases

Section 3

INSTALLATION

3.0 General — This Chapter describes general wiring and wire-routing procedures to be followed by the electrical installation crew when installing the IQ-2000 and its associated Ampgard starter with a motor and its related machine or process equipment. The information listed here builds on earlier chapters in this manual and will be unnecessarily difficult unless they are read first.

3.1 Ampgard Schematic — The wiring between the Ampgard starter and the IQ-2000 is factory installed by Westinghouse. Each specific hardware configuration is shown on a unique Ampgard Schematic shipped with the unit. (A typical Ampgard Schematic is shown in Figure 3.1.) The drawing is for a Class 11-202 induction, full-voltage, non-reversing unit.

3.2 Wiring Plan Drawings — It is necessary for the customer application engineer to develop a suitable wiring plan for use by the installation team. It must reflect the control lines to the IQ-2000 or between the IQ-2000 and its associated machine or process equipment. In this manual the wiring plan is called "wiring plan drawings," although individual companies will probably have different terminology. Whatever the term, these drawings detail all customer wiring which must be performed in the field after the Ampgard and its associated IQ-2000 are shipped from Westinghouse.

The Ampgard Schematic shows all the control input and output lines for the application; the wiring plan drawings list the designations of these lines.

Note: in cases of "retrofits" where the IQ-2000 is shipped separately without an Ampgard starter, the wiring plan drawings must list the:

- Wiring between the IQ-2000 and interposing relays
- Main contactor(s) wiring
- Potential, current, ground current, and power transformer wiring

In short, it must list all of the wiring that is normally documented by the Ampgard Schematic.

3.3 Wiring Guidelines — The following wiring guidelines must be observed by the electrical installation crew when installing the IQ-2000 and connecting it with its associated machine or process equipment.

3.3.1 Wire Routing — When routing wires between the Ampgard and the associated machine or process equipment, follow these guidelines:

DANGER

Insure that the incoming AC power and all "foreign" power sources are turned OFF and locked out before performing any work on the Ampgard or IQ-2000. Failure to observe this practice can result in serious or even fatal injury and/or equipment damage.

Guideline 1 — All user-installed control lines and the RTD conductors connecting with the draw-out panel must be carefully coiled and secured to the factory-installed low-voltage conductors. (See Figure 3.2.) This coil of conductors provides a quantity of slack required for draw-out panel movement. The coil is positioned **behind** the panel as the panel is pushed into the enclosure. In order to make the coil, bundle the conductors neatly with tie-wraps, or equivalent means.

Once wiring is complete, insure that the coil is properly positioned and that it is able to clear any obstruction that may exist as the draw-out panel moves in and out.

Guideline 2 — Do not route control or RTD conductors through the high-voltage compartment of the Ampgard starter. If it is necessary to do so, consult the applications department, Westinghouse Control Division, for specific instructions.

Guideline 3 — Separate the low-voltage (120 VAC) from the high-voltage (440 VAC, or higher) conductors as much as possible. In general, maintain a minimum distance of 1.5 ft. (45 cm) between the two types.

3.3.2 Types of Wire — The following guidelines list the generally acceptable types of conductors and wiring practices used in the industrial environment. For specific types of wire, consult your application engineer.

Guideline 4 — Any low-voltage control wiring routed out of the Ampgard cabinet should be at least AWG No. 14 stranded copper wire.

Guideline 5 — The wiring between the RTD Module contained in the starter cabinet and the RTDs in the motor must be AWG No. 18 3-conductor, shielded cable. (See Figure 3.3.) Use Belden No. 8770, or equivalent. Note: in cases where the leads from the motor or other resistance temperature devices provide only 2 leads each, connect 2 conductors from the RTD Module to one of these leads. Follow Figure 3.4 carefully when selecting the 2 conductors to tie together. Also it is important to connect the 2 conductors as close to the motor as possible.

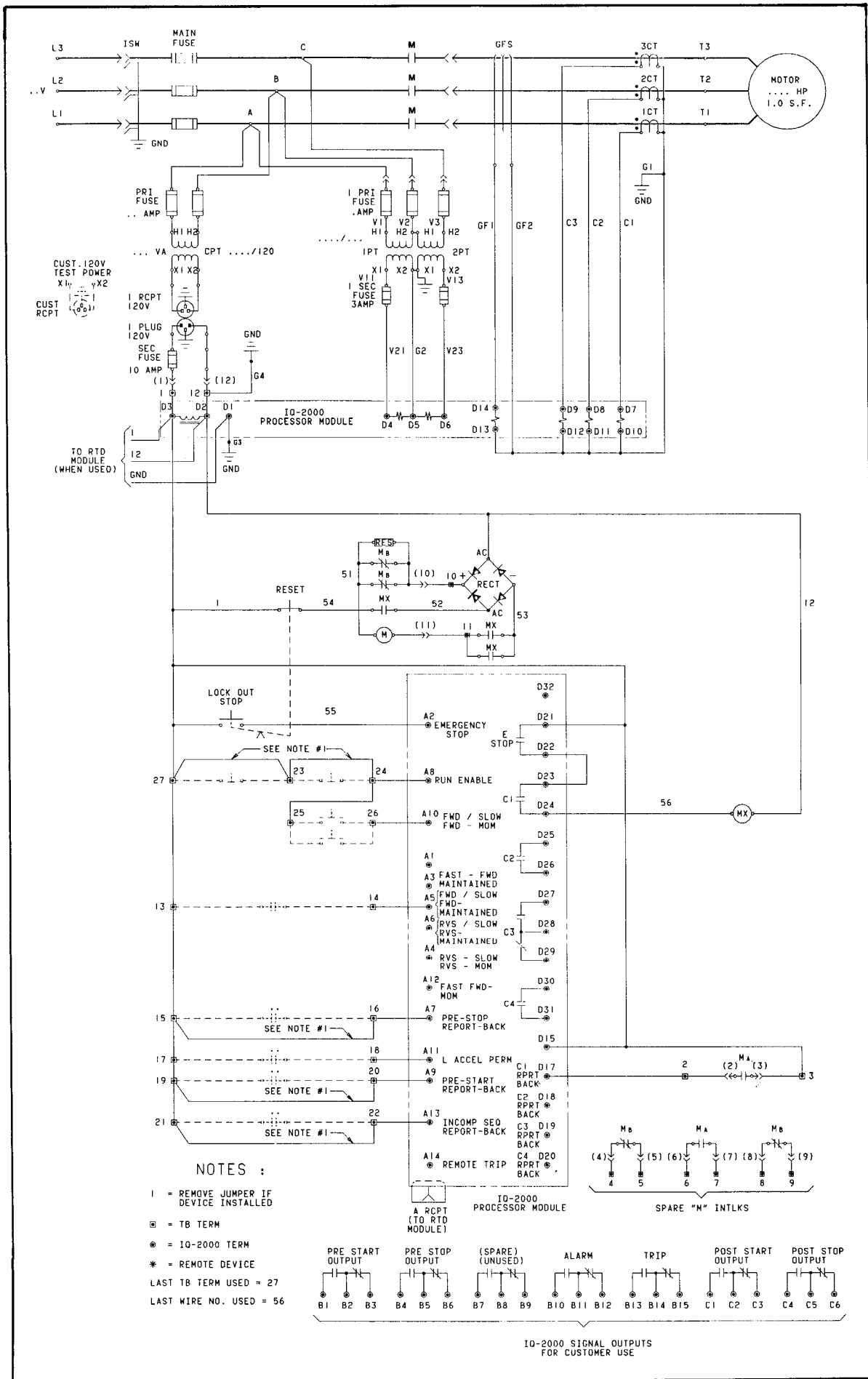

Figure 3.1 – Ampgard Schematic (typical)

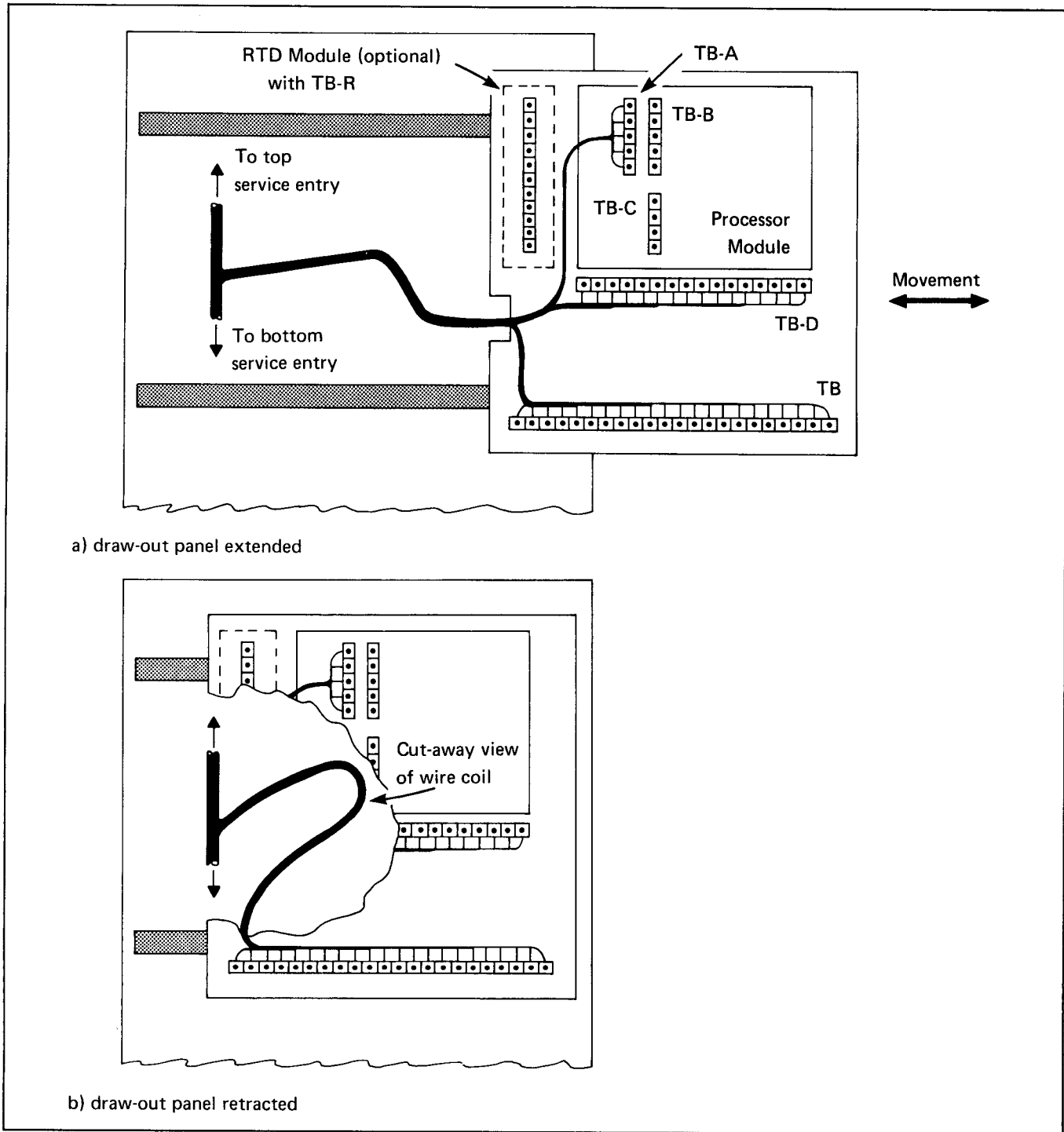

Figure 3.2 – Wiring to Draw-Out Panel

Guideline 6 – Connect the shield drain wires from RTD cables to the common (COM) terminals on the RTD Module, as shown in Figure 3.3 Note: connect the shield **only** at the RTD Module. Use shrink tubing or electrical tape to insure that the shields do not make accidental contact with ground or other terminals at the RTD end.

3.3.3 Grounding – A typical grounding plan for an Ampgard starter is shown in Figure 3.5. Note carefully these

guidelines before making grounding connections. If the RTD Module is installed in the field, be sure to run a separate ground wire to the unit.

Guideline 7 – Install an “equipment grounding conductor” between the Ampgard’s ground stud (or grounding bus) and a suitable plant grounding bus or to earth ground. Consult the local application engineer or the wiring plan drawings for information on specific gauges.

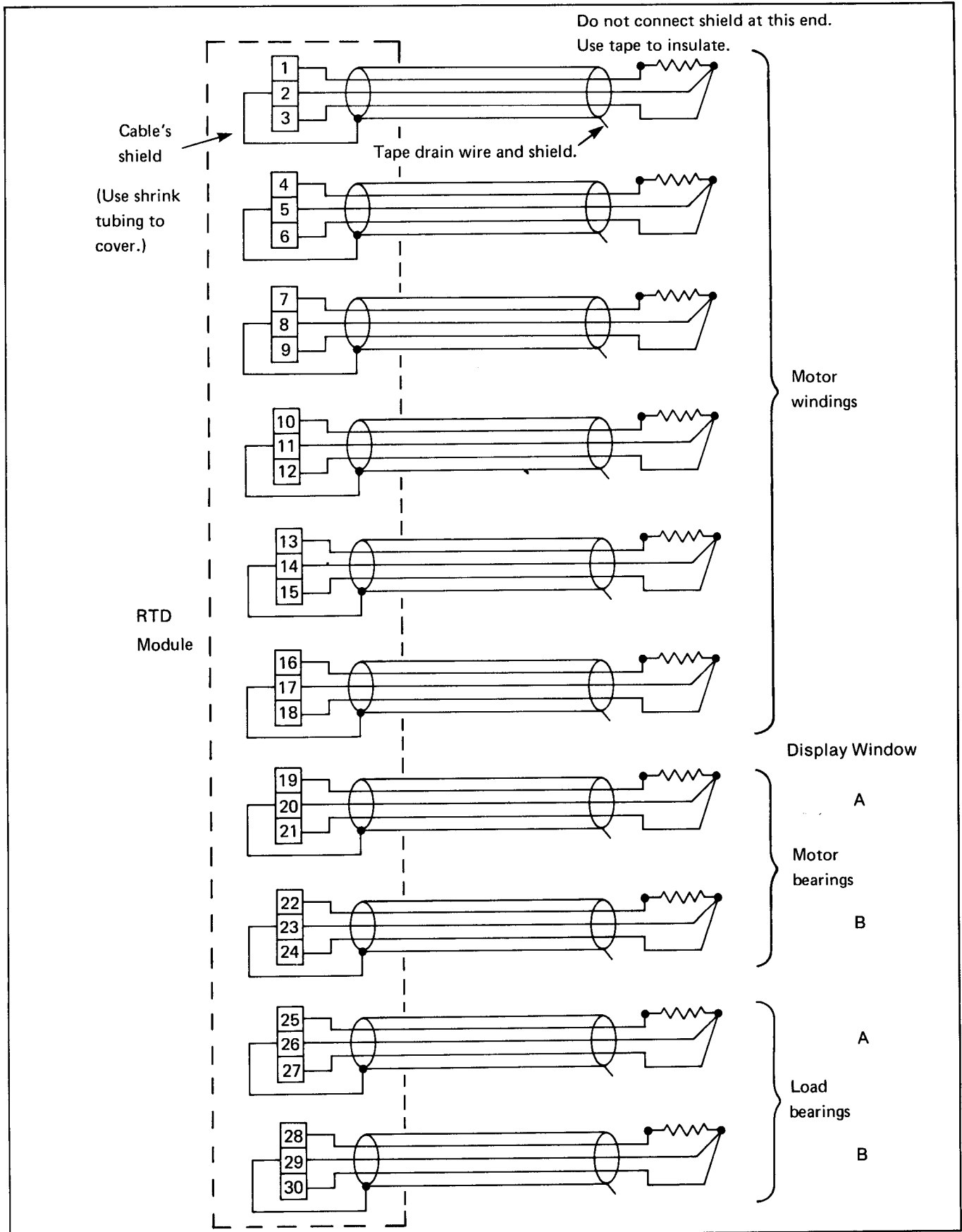

Figure 3.3 – RTD Wiring (3-lead type)

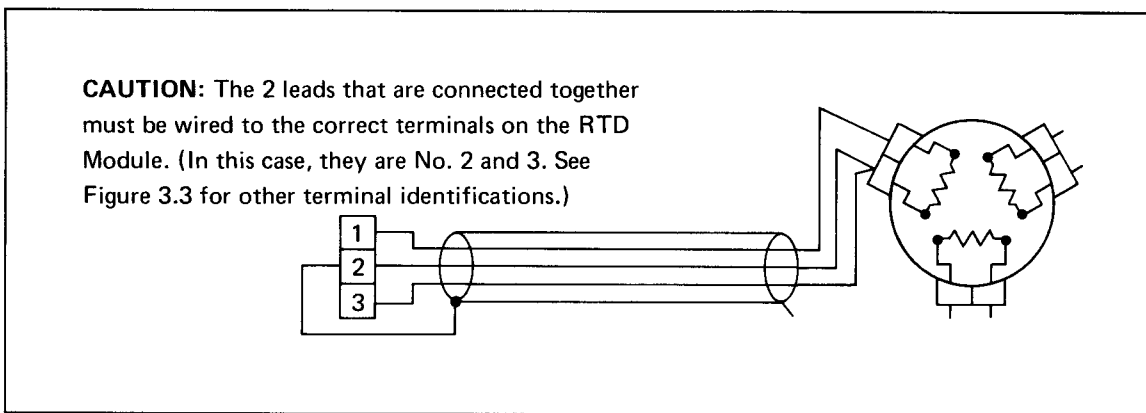

Figure 3.4 – Two-Lead RTD Wiring

3.4 Wiring Checklist – Complete the following checks on the field-installed wiring **before** applying AC power for the first time.

Each item contained in the checklist also has a small box at its immediate left. The box is intended to be used to provide verification that a specific step has been performed. Follow these checks in sequence.

- When the Ampgard isolating switch and the high-voltage door are open, the step-down control transformer is accessible. Remove the plug from the receptacle to disable the secondary circuit, as shown in Figure 3.7.
- Verify that all “foreign” external power sources are disconnected from the starter cabinet.
- Open the access door to the low-voltage compartment. Examine the wiring terminals of the draw-out panel. Look for foreign material, pieces of wire, screws. Check screws for tightness.
- Verify that the field-installed wiring is exactly as shown on the wiring plan drawings.
- If the application contains an RTD Module, verify that the cable shields are wired to the correct terminals, as

shown in Figure 3.3. Also verify that the shield drain wires are insulated with tape or shrink tubing so they cannot ground nor cause shorts.

- Be sure that cable shields and drain wires are **not** connected at the RTD end. They are to be cut short and insulated.
- In some cases there may be factory-installed jumpers between the terminals as shown in the solid jumpers in Figure 3.6. It is necessary to determine whether or not there should be jumpers installed. Consult the wiring plan drawings to determine if any jumpers should be in place or removed for each application.

Note: when an external device, such as a limit or pressure switch, is to be wired between the terminals, as shown in Figure 3.6, the factory-installed jumper must be removed.

- Move the draw-out panel in and out to make sure that wiring to the panel does not bind or scrape in such a way that the insulation is damaged.
- Verify that there are no stray strands of wire which could cause shorts.

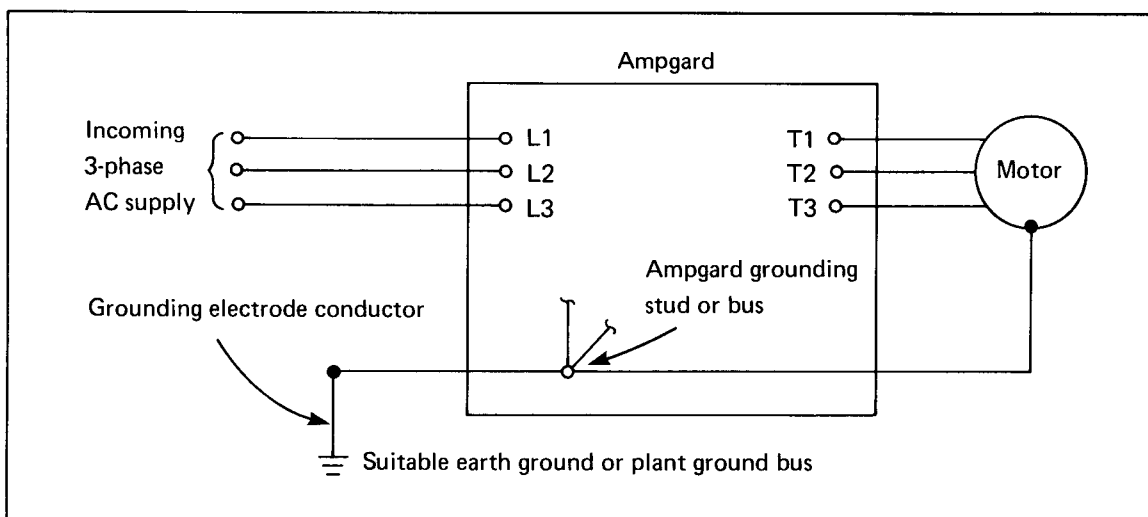

Figure 3.5 – Typical Grounding Plan (simplified)

- Temporarily plug the control power receptacle, as shown in Figure 3.7, into a 120 VAC extension cord receptacle. Using a meter, check polarity and verify that 120 VAC ($\pm 15\%$) is present.

The application is now ready to be started up as detailed in Chapter 4. Do **not** start the motor at this time. Wait until the setpoints have all been entered into the control and the Ampgard is sequenced with the external 120 VAC used to temporarily control power (test power).

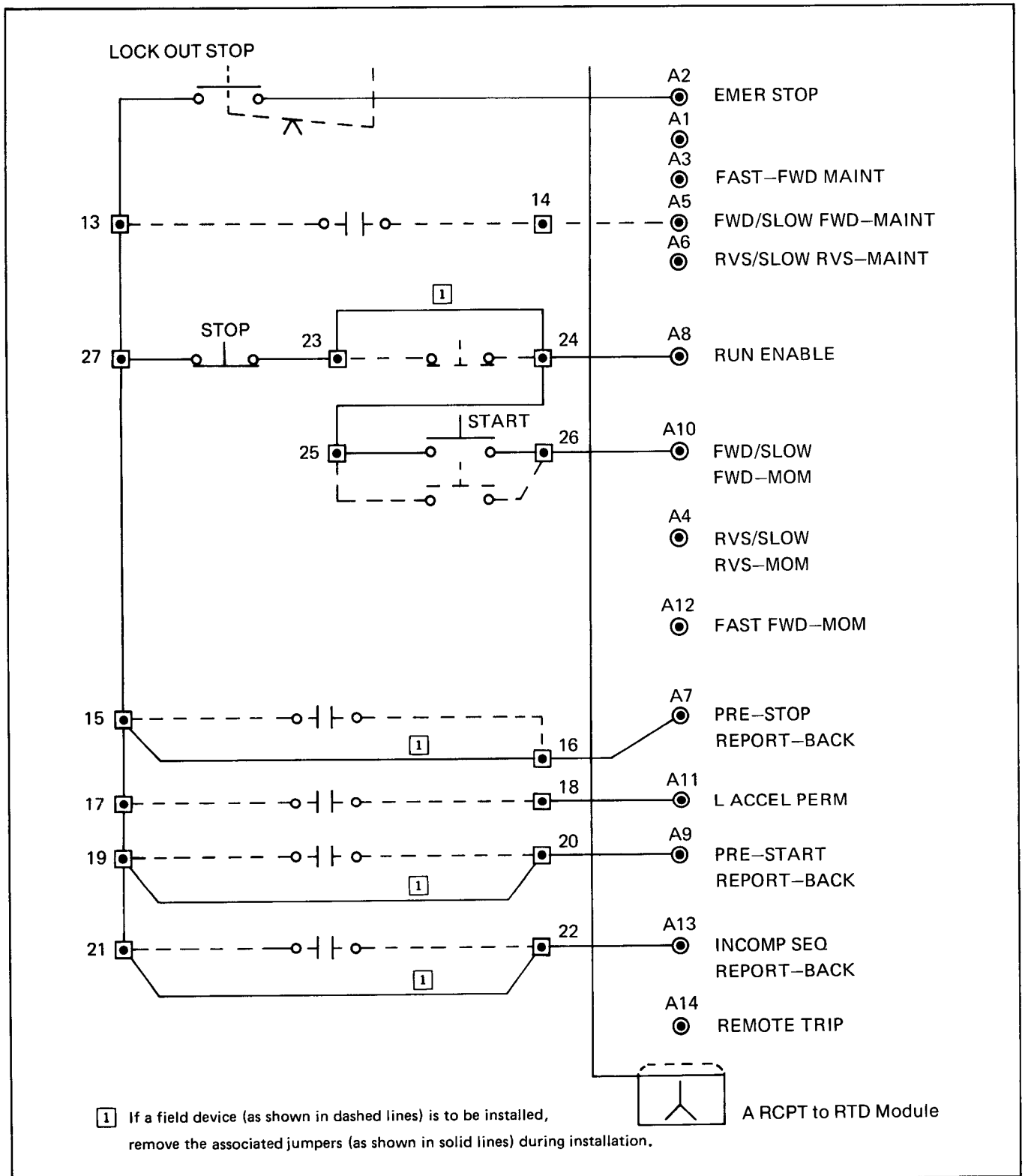

Figure 3.6 – Jumper and Field Wiring

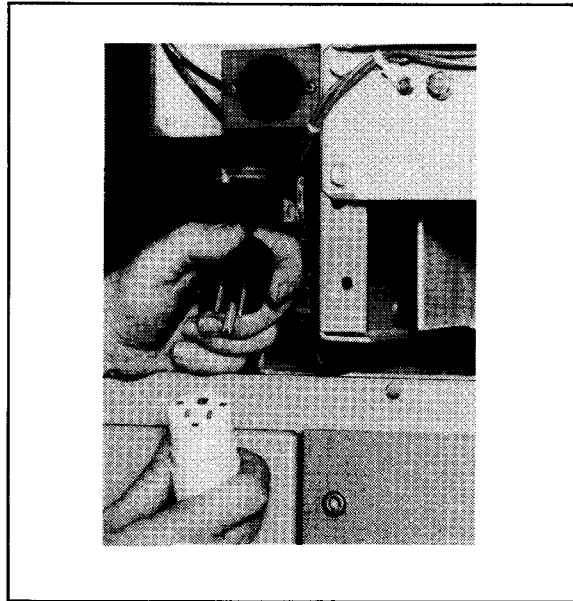

Figure 3.7 – Ampgard Internal View

Section 4

STARTUP

4.0 General – This chapter describes the IQ-2000's Operator Panel and explains setpoint entry procedures. It is designed primarily to assist with the starting up of a system. Detailed explanations of available setpoint functions, their ranges and features are contained in Chapter 6, "Setpoint Value Considerations." Therefore, Chapter 4 is designed primarily for the individual responsible for the startup, and Chapter 6 is designed primarily for the engineer in charge of the specific application.

Note that the setup cannot be performed without a completely and correctly filled in Setpoint Record Sheet, which is shown in Table 6.A.

CAUTION

Do not attempt to startup an IQ-2000 or to enter setpoints without a completed and validated Setpoint Record Sheet. Equipment damage could result if incorrect data is entered.

The information contained in this chapter is organized into 5 major groupings:

- Operator Panel description (Par. 4.1)
- Initial AC power-on checks (Par. 4.2)
- Entering setpoint values (Par. 4.3)
- Initial motor startup (Par. 4.4)
- Initial main power-on (Par. 4.5)

4.1 Operator Panel Description – The Operator Panel is primarily controlled by the RUN/PROGRAM keyswitch which provides 2 modes of operation:

- **Run Mode.** When the keyswitch is in the RUN position, normal operation of the motor, reviewing of programmed setpoint values, and monitoring of setpoint values may all be performed. Additionally, electrical characteristics, including the actual values of many functions, can be monitored.

- **Program Mode.** When the keyswitch is in the PROGRAM position, the programmed setpoint values can be displayed and/or modified. In this mode, starting and running of the IQ-2000 is inhibited.

Note: when the motor is running, turning the keyswitch to the PROGRAM position will not cause the program mode to be initiated until the motor is stopped.

In general, all Operator Panel operations may be divided into 3 types:

- **Programming Setpoints.** In this operation, the setpoint values for the various functions are entered. When programming setpoints, it is necessary to place the RUN/PROGRAM keyswitch in the PROGRAM position.
- **Reviewing Setpoints.** In this operation, the previously programmed setpoint values can be monitored. When reviewing setpoints, the RUN/PROGRAM keyswitch is normally placed in the RUN position. The programmed setpoint values may also be reviewed when the motor is not running and the keyswitch is in the PROGRAM position. (See Paragraph 4.1.5 for details on the reviewing operation.)
- **Monitoring System Characteristics.** In this operation, actual electrical characteristics are displayed, according to a predetermined list, in the FUNCTION window of the Operator Panel. The actual values associated with these selected functions will be displayed. When monitoring characteristics, the RUN/PROGRAM keyswitch must be in the RUN position. (Refer to Chapter 7 for a complete description.)

In the following paragraphs the function of each switch, pushbutton and indicator is listed and explained. Refer to Figure 4.1 where an Operator Panel is shown.

4.1.1 RUN/PROGRAM Keyswitch – IQ-2000 operations are controlled by a 2-position keyswitch labeled RUN/PROGRAM. The key may be removed when it is in the RUN position. The selected position determines the operations the control will perform. These are:

- **Run.** With the switch set to RUN, the IQ-2000 enters the run mode which controls normal operation of the motor including starting, running and stopping. This is also the normal position for the reviewing of programmed setpoints or the monitoring of electrical characteristics.

When switching from PROGRAM to RUN, there is a delay of 5 seconds after which the message CALC SETPOINTS is displayed for 15 seconds. After this delay the RUN indicator lights, and the motor can be started when an external start command is received by the IQ-2000.

- **Program.** With the keyswitch set to PROGRAM and the motor stopped, the control enters the program mode which allows the programming of setpoint

values. The PROGRAM LED indicator lights when this mode is entered.

4.1.2 FUNCTION Window – The FUNCTION window displays the following information:

- Names of setpoint functions. (Note that these can be displayed in either the run or program mode.)
- Names of selected electrical characteristics. These include motor current or line voltage. (The numerical values are displayed in the VALUES window.)
- Error and status messages. (A complete listing of messages is given in Chapter 7, Troubleshooting.)

4.1.3 VALUES Windows – There are 3 numerical VALUES windows on the operator Panel. These are labeled with the letters A, B and C and, also, with the titles TRIP, ALARM and TIME. The information displayed is:

- Trip, alarm and time setpoint values entered when in the programming mode.
- Trip, alarm and time programmed setpoint values being reviewed when in the run mode.
- Selected electrical characteristics and their numerical values can be displayed when a monitoring operation is performed in the run mode.
- Trip, alarm and time setpoint values that cause the trip/alarm condition to be displayed in the run mode. In this instance, the SET POINTS LED indicator on the Operator Panel lights to indicate that the values displayed are setpoint values.

4.1.4 ADJUST Pushbuttons – The setpoint values may be raised or lowered by means of the upper and lower ADJUST pushbuttons, respectively. The control must be in the program mode to modify the setpoint values. The numerical values will increase or decrease continuously until the pushbutton is released.

When a specific setpoint function is first displayed, all related numerical values in the A, B and C VALUES windows are also displayed. Press the SELECT pushbutton once, and only the A window displays a value—which can then be modified by means of one or the other ADJUST pushbuttons. Press SELECT again, and the B window displays a value, if one is called for by that function.

4.1.5 STEP Pushbutton – The 2-function STEP pushbutton is used in all 3 operations, as described here:

- **Programming.** When in the programming mode, depressing the STEP pushbutton causes the various setpoint functions to be sequentially advanced and displayed. (The sequence is identical to the listing in the Setpoint Record Sheet.)
- **Monitoring.** When in the run mode, each time the STEP pushbutton is depressed, a new characteristic is displayed: the name is in the FUNCTION window, and the numerical values are in the VALUES windows. The display will continue until the STEP

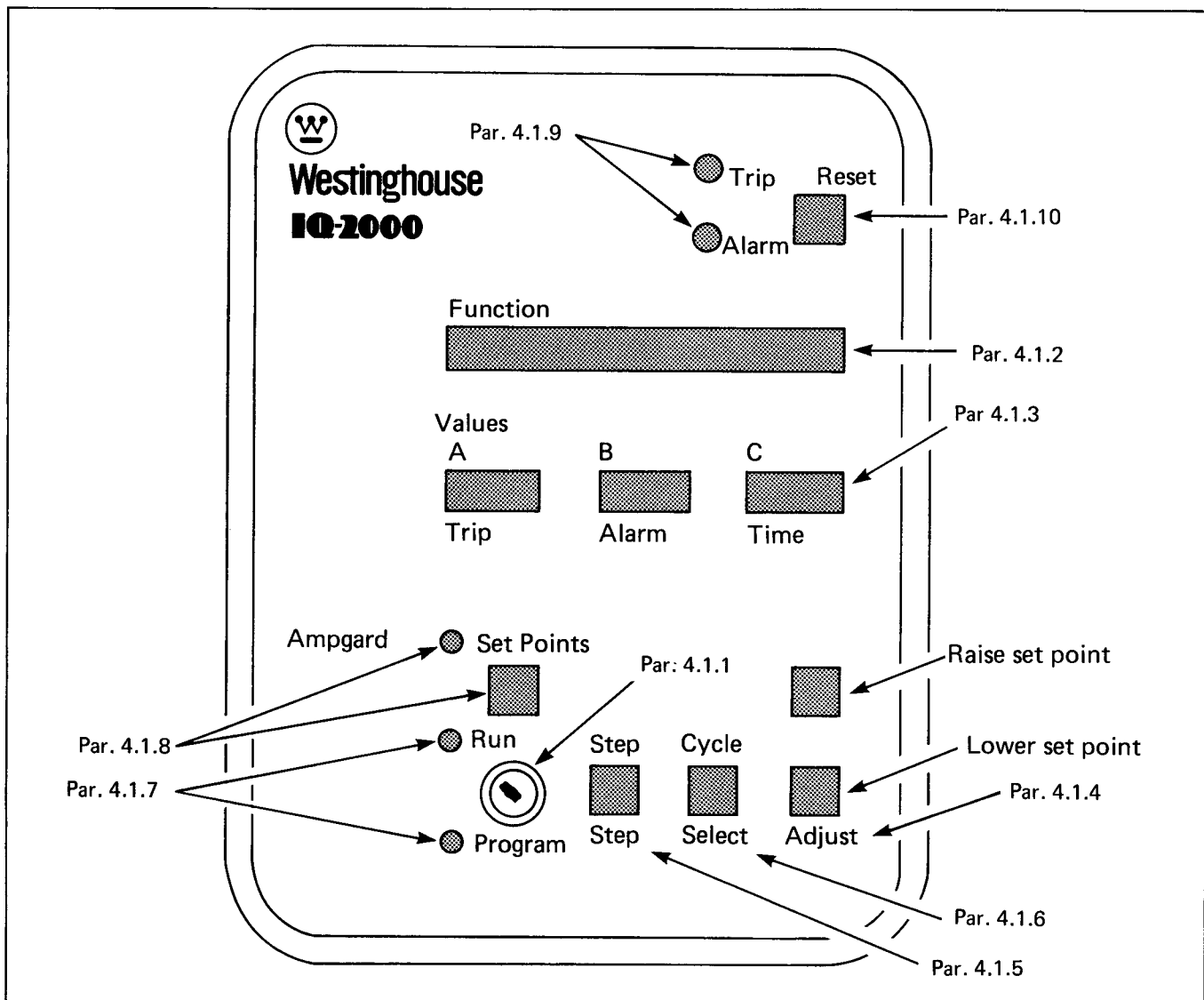

Figure 4.1 – Operator Panel with Manual References

pushbutton is depressed or an alarm, trip or stop condition occurs.

Note that the selected characteristics appear according to a fixed order. (A complete listing is shown in Table 7.A.)

- **Reviewing.** When in the run mode, depressing the SET POINTS pushbutton once and the STEP pushbutton once causes the programmed setpoint values to be displayed. The first values displayed relate to the first function in the fixed sequence, which is always winding temperature. Depressing STEP repeatedly advances the display through the list noted on the Setpoint Record Sheet.

Each setpoint function is displayed for up to 4 seconds. If the STEP pushbutton is not depressed again, the IQ-2000 automatically terminates this reviewing function.

4.1.6 CYCLE/SELECT Pushbutton – The function of the CYCLE/SELECT pushbutton varies with the type of operation being performed. Each operation is listed in the following paragraphs.

- **Programming Setpoints.** When in the programming mode, first depress the STEP pushbutton to initiate the display of a setpoint function. At this time all programmed setpoint values that apply are displayed in the VALUES window. Then depress the CYCLE/SELECT pushbutton so that only a single value will be displayed. (This is necessary when modifying previously programmed values.) After the first time the pushbutton is depressed, only the VALUES window labeled TRIP contains a display. After a second depression, the ALARM window displays a value. After a third, the TIME window illuminates.

Once an individual value is displayed, it can be changed. Depress the upper or lower ADJUST pushbuttons in order to increase or decrease the value.

In the case of a function with a single setpoint, it is not necessary to press the CYCLE/SELECT pushbutton. Depress the appropriate ADJUST pushbutton immediately to modify the value.

- **Monitoring.** When in the run mode, depress the CYCLE/SELECT pushbutton to cause the IQ-2000 to sequence through each electrical characteristic. Each of these will be displayed for approximately 6 seconds. After all characteristics have been displayed, the sequencing stops.

4.1.7 RUN, PROGRAM LEDs — The red RUN and PROGRAM LEDs indicate which mode is active. If AC line power is applied but neither of these indicators lights, an alarm or trip condition has occurred.

4.1.8 SET POINTS Pushbutton, LED — The SET POINTS pushbutton is used only in the run mode. Depressing it is a necessary precondition for using the STEP pushbutton to sequence through the setpoint functions. Press STEP repeatedly to advance through the sequence. (The SET POINTS pushbutton is not used in the programming mode.)

The red LED associated with the SET POINTS pushbutton lights after the SET POINTS pushbutton is depressed.

Setpoint functions are each displayed for approximately 4 seconds. Unless the STEP pushbutton is depressed again within this time, the monitoring operation ceases.

To automatically review all setpoints, depress the SET POINTS pushbutton and then depress the CYCLE pushbutton. The setpoint functions, along with their respective setpoint values, will be sequentially displayed for approximately 4 seconds each in the order listed in Table 6A.

If a trip or alarm condition occurs, the setpoint function which initiated that condition is displayed in the FUNCTION window. Also, the associated programmed values are displayed and the red SET POINTS LED lights.

4.1.9. TRIP, ALARM LEDs — The red TRIP and ALARM LEDs are used to indicate that the actual value of a function equals or exceeds its trip or alarm programmed setpoint value. These LEDs function in the run mode.

When one of these conditions occurs, the specific setpoint function which initiated the condition is displayed in the FUNCTION window. Also, the programmed setpoint value is displayed in the VALUES window. At this time the red SET POINTS LED lights, thereby indicating that the displayed values are the setpoint values.

In the case of an alarm condition, the Alarm Relay will energize until the actual value drops below the programmed value. As it passes through the setpoints, the alarm condition automatically clears, and the Alarm Relay is de-energized.

In the case of a trip condition, the motor enters a controlled stop cycle. Once the actual value is lower than the setpoint, the motor can be restarted by first depressing the RESET pushbutton and then one of the application's START pushbuttons.

4.1.10 RESET Pushbutton — The RESET pushbutton is used to manually reinitiate operation after the actual trip value falls below the programmed setpoint value.

Depressing the RESET pushbutton may not, in many instances, immediately cause resumption of operation. For example, if the trip condition results from the rotor temperature accumulator sensing an overtemperature level, the RESET pushbutton will have no effect on the motor until the rotor temperature drops below 75% of the trip setpoint value. (The rotor temperature is monitored in the temperature storage accumulators.)

4.2 Initial Programming and Sequencing Checks — Before entering any setpoint values, the following hardware checks must be performed.

— DANGER —

The following start-up procedures must be performed only by qualified personnel who are familiar with the IQ-2000 and its associated controlled motor and machines. Failure to observe this caution can result in serious or even fatal personal injury and/or equipment damage.

These initial checks only need to be performed once—just before initial AC power is applied at installation. Note that a box appears to the left of each check. As each item is completed, mark it off in the corresponding box in order to avoid skipping one.

The following checks are divided between those to be performed with the main power off but with control power available, and those with the main power on just prior to starting the motor.

4.2.1 Power Off — With the incoming AC line power locked off at the starter's isolation switch, perform these checks:

- Verify that the isolation switch on the starter cabinet is in the OFF position.
- Verify that there is **no** possibility of backfeeding of control power through the control transformer or potential transformers, thereby resulting in high voltage being present on the primary side of the transformers.
- Pull the draw-out panel out of the enclosure. Verify that all items from the checklist in Chapter 3, Paragraph 3.4 have been performed.
- Temporarily plug the control power receptacle, as shown in Figure 3.7, into a 120 VAC extension cord receptacle. Using a meter, check polarity and verify that 120 VAC ($\pm 15\%$) is present.

4.2.2 Control Power Only – These checks are to be performed when control power is first applied to the IQ-2000 but without power being available to the motor.

- Verify that 120 VAC (±15%) is available at terminals TB-D3 and TB-D2. (See Figure 3.1, upper left-hand area.)
- Observe the Operator Panel. The red TRIP and ALARM indicators should be OFF. If either is ON, refer to Chapter 7, Troubleshooting.
- Insert the key into the RUN/PROGRAM keyswitch. Turn it to the PROGRAM position.

At this point the PROGRAM LED should light, and the FUNCTION window should display the message WINDING TEMP. (If they do not, refer to Section 7, Troubleshooting.)

- Turn the keyswitch to the RUN position. After 5 seconds the message CALC SETPOINTS is displayed for approximately 20 seconds. After this the FUNCTION window displays the message READY, and the RUN LED lights.

4.3 Entering Setpoints – This discussion of setpoint value entry is divided into 2 parts:

- Setpoint Record Sheet
- Value entry

4.3.1 Setpoint Record Sheet – Locate the Setpoint Record Sheet for the specific IQ-2000 being started up. This sheet should be filled in and made available by the application engineer. (A blank sheet is shown in Figure 4.2, but refer to Chapter 6, Table 6.B.)

SETPOINT RECORD SHEET					
Plant Designation: _____		End User: _____		Ampgard Schematic No.: _____ (drawing number)	
Plant Location: _____		OEM: _____		Motor Designation: _____	
				Motor Model No.: _____	
	Setpoint Function	Trip [1]	Alarm [2]	Time [3]	Setpoint Value Ranges
1	WINDING TEMP [4]				Trip & alarm: 0° to 199°C (1°C incre.)
2	MOTOR BGR TEMP [4]				Trip & alarm: 0° to 199°C (1°C incre.)
3	LOAD BGR TEMP [4]				Trip & alarm: 0° to 199°C (1°C incre.)
4	GROUND FAULT				Trip: 4 to 12 amps (1 amp incre.) Alarm: 0 to 12 amps (1 amp incre.) Time: 0 to 5 sec. (1 sec. incre.)
5	INST OVERCURRENT				Trip: 300 to 1500% of full-load amperes (in 100% incre.) Use numbers 3 to 15 only.
6	LOCKED ROTOR CUR				Trip: 300 to 1200% (in 10% incre.) Use numbers 30 to 120 only. The decimal point here shown as: 3-0, 12-0 Time: 0 to 60 sec. (in 1 sec. incre.)
7	LONG ACCELERAT				Time: 0 to 99 sec. (in 1 sec. incre.)
8	JAM				Trip: 70 to 1200% of full-load amps (in 1% incre.) Use numbers 70 to 1200. Time: 0 to 5 sec. (in 1 sec. incre.)
9	UNDERLOAD START				Time: 0 to 25 sec. (in 1 sec. incre.) [5]
10	UNDERLOAD RUN				Trip: 0 to 90% of full-load amps (in 1% incre.) Time: 0 to 10 sec. (in 1 sec. incre.)
11	ULTIMATE TRIP				Amp: 85 to 125% of full-load amps (in 1% incre.) ¹ Use numbers 85 to 125
12	OVERVOLTAGE [6]				Trip: 0 to 9999 VAC (in 1 volt incre.) Time: 0 to 99 sec. (in 1 sec. incre.)
13	UNDERVOLTAGE [6]				Trip: 0 to 9999 VAC (in 1 volt incre.) Time: 0 to 99 sec. (in 1 sec. incre.)
14	PRE-START TIMER				Time: 0 to 60 sec. (in 1 sec. incre.)
15	PRE-RUN TIMER				Time: 0 to 60 sec. (in 1 sec. incre.)
16	PRE-STOP TIMER				Time: 0 to 60 sec. (in 1 sec. incre.)
17	INCOMPL SEQUENCE				Time: 0 to 240 sec. (in 1 sec. incre.)
18	ANTI-BACKSPIN				Time: 0 to 240 sec. (in 1 sec. incre.)

(Partial illustration of form.)

Figure 4.2 – Setpoint Record Sheet (typical)

DANGER

Do not attempt to enter any values without using the appropriate Setpoint Record Sheet. Improper operation and/or personal injury could result if this procedure is not followed.

Before entry, refer to the Sheet and note the following:

- A total of 28 functions and their associated setpoint values are shown on the Sheet. Not all IQ-2000s require all functions; thus it may be unnecessary to enter the full number available. (With the single exception of P.T. Ratio, any value may appear for an unused function since no field device will be wired into the control.)
- The name of each function is sequentially displayed in the FUNCTION window in the same order as they appear on the Sheet.

- Some functions require that 3 setpoint values (trip, alarm and time) be entered. Others require only 1 or 2.
- In some cases values other than 0 may already be factory-entered. It may thus be necessary to increase or decrease these numbers to match the desired setpoints.

4.3.2 Value Entry – The following steps are to be followed in order to enter setpoint values.

Step 1 – Turn the RUN/PROGRAM keyswitch to the PROGRAM position. At this time the FUNCTION window displays the message WINDING TEMP. If any setpoint values were previously entered, they will be shown in the VALUES windows. (See Figure 4.3.) If not, zeroes will be shown.

Step 2 – If a function other than the winding temperature setpoint function is to be modified, repeatedly depress the STEP pushbutton until the desired function is displayed.

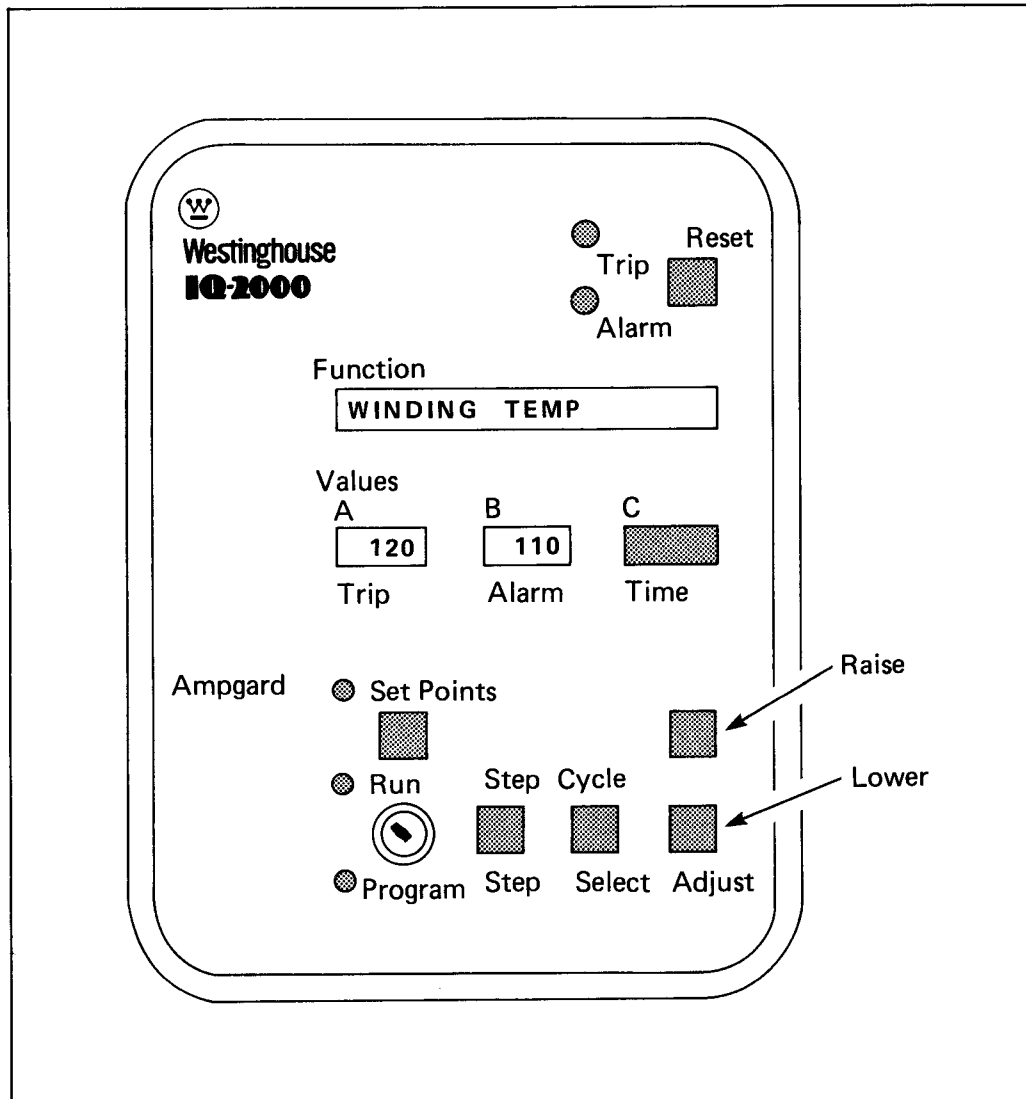

Figure 4.3 – Winding Temperature Displays

Step 3 – It is necessary to depress the CYCLE/SELECT pushbutton once to display and allow modification of the trip value. Note: if the function does not have a trip setpoint value associated with it, the alarm value will be displayed. If the setpoint function has only one value associated with it, the CYCLE/SELECT pushbutton need not be used.

Step 4 – At this point the trip value can be modified. Use the ADJUST pushbuttons to increase or decrease the value, as required.

Step 5 – Once the trip value is modified, depress the SELECT pushbutton to display the alarm setpoint. Modify it as necessary.

Step 6 – In order to advance to the next function, depress STEP once. Each time STEP is depressed, the displayed function advances.

Step 7 – While referring to the Setpoint Record Sheet, step through each function. Enter values for each function used by the specific application.

Step 8 – After all values are entered, simply depress the STEP pushbutton to again display the first setpoint function and its associated values. Carefully compare the entered value with the desired value as noted on the Setpoint Record Sheet. Confirm that the 2 values match. Modify the programmed value if necessary.

Step 9 – Move on to subsequent functions in order to confirm the correctness of their entries.

Step 10 – Turn the key to the RUN position and remove it.

4.4 Initial Motor Startup – Depending on the motor type, specific application and completeness of the installation, it

may be a good practice to disconnect the load from the motor before applying power for the first time. Consult the application engineer for suggestions. Always keep in mind the cautions listed in Paragraphs 4.2 and 4.3 when first starting the motor.

CAUTION

Since the IQ-2000 is phase-sensitive, verify that the incoming AC supply lines (L1, L2, and L3) are properly phased and wired to the IQ-2000. Failure to do so will result in a trip condition when power is first applied.

4.5 Initial Main Power-on – Before closing the isolation switch associated with the motor starter, the following hardware checks must be performed:

- Remove the extension cord temporarily providing 120 VAC control power. (Plug the power cord into the intended receptacle as shown in Figure 3.7.)
- Inspect the motor and driven mechanics to verify that the devices—such as the couplings, belts, etc.—are secure and that all required safety guards, shields and/or covers are in place. If possible, manually rotate the driven mechanisms to verify free movement.
- Clear all personnel from the immediate area of the motor and driven mechanisms.
- Close the starter cabinet's isolation switch.
- Verify that 120 VAC ($\pm 15\%$) is available at terminals TB-D3 and TB-D2. (See Figure 3.1, upper left-hand area.)

Section 5

APPLICATION CONSIDERATIONS

5.0 General — This chapter describes the protective and control characteristics of the IQ-2000. It is intended for the engineer who is responsible for matching the control to an individual application. Information presented here is especially useful for understanding the setpoint value considerations described in Chapter 6. It may be helpful to read Chapter 5 and 6 quickly, and then reread and study Chapter 5 slowly. After doing so, reread Chapter 6, Paragraph 6.0, and select those setpoints from Table 6.A which relate to the specific application.

5.1 Motor Protection — The IQ-2000 protects the motor, starter, and load in the following ways:

- Motor overload protection
- Overtemperature protection
- Instantaneous overcurrent
- Ground fault protection
- Phase loss/phase reversal/phase unbalance (voltage)
- Phase loss and unbalance (current)
- Overvoltage protection
- Undervoltage protection
- Motor bearing temperature
- Jam
- Underload
- Long acceleration provision
- Load bearing temperature

5.1.1 Overload Protection without RTDs — The motor overload protection feature guards against excessive motor temperature. If the temperature of the rotor, as calculated by the IQ-2000, reaches 75% of the specified maximum, an overload warning message is displayed. If the calculated motor temperature exceeds the maximum permissible rating, a trip condition occurs, and the motor stops. Note that the motor will not be permitted to restart until the temperature of the rotor, as calculated by the IQ-2000, falls below 75% of its maximum value. (The algorithm has both a heating and a cooling calculation.)

To do this, a microprocessor located in the Processor Module maintains a short-term history of the motor's operation. (A rotor protection algorithm maintains the history. See Figure 5.1.) The following variables are used as input data for the history:

- Motor current (I_1), the positive sequence current
- Motor current (I_2), the negative sequence current or "unbalanced current"
- Time

This data can be considered as the current feedback from the motor.

In addition to the variable data feedback from the motor, certain motor constants are needed. They are supplied to the IQ-2000 when the setpoints are programmed into the memory. These are:

- Full-load amps
- Maximum allowable locked-rotor current and stall time
- Ultimate trip

With these motor constants and with the IQ-2000 accurately measuring motor currents and time, an accurate tracking of the calculated rotor temperature is accomplished.

5.1.2 Overload Protection with RTDs — The temperature data obtained from the addition of RTDs is used in the following 2 ways by the IQ-2000 to help protect the motor:

- Direct measurement of the winding temperature versus the programmed trip temperature. (This gives a fixed trip point based on actual, measured stator winding heating and cooling.)
- RTD winding temperatures—when combined with the monitored positive sequence motor current, the negative sequence motor current and time, in the algorithm for motor protection—incorporates the anticipated cooling of the rotor based on the actual winding temperature. (This will be described in more detail in Paragraph 5.1.4.)

The following motor input variables are used by the IQ-2000:

- Motor current (I_1), the positive sequence current
- Motor current (I_2), the negative sequence current or "unbalanced current"
- Time
- Stator winding temperature

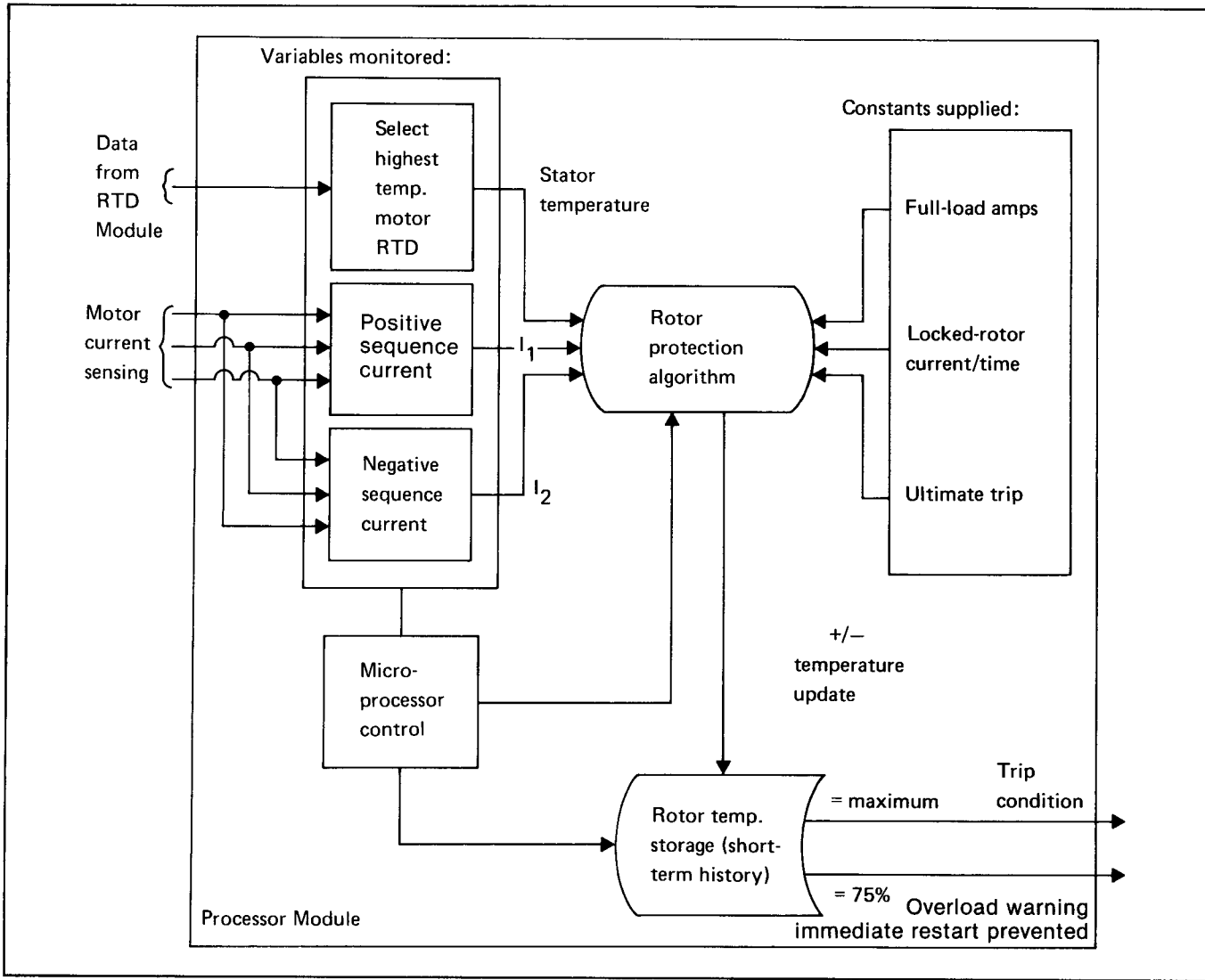

Figure 5.1 – Rotor Temperature Tracking

This data can be considered as the feedback from the motor. (See Figure 5.1.)

In addition to the variable data, certain motor constants are needed. They are supplied to the IQ-2000 when the setpoints are programmed into the IQ-2000's memory. These are:

- Full-load amps
- Maximum allowable locked-rotor current and stall time
- Ultimate trip
- Winding temperature trip value

The IQ-2000 has these setpoints plus an accurate measurement of the feedback variables. Thus the IQ-2000 can more accurately protect the rotor, while the stator is protected by direct measurement through the RTDs.

5.1.3 Protection Curve – The motor protection curve defines the motor-versus-time relationship that exists as a

direct result of the IQ-2000's hardware and the programmed setpoint values. (See Figure 5.2.) Ideally this curve is located as close as possible to the motor damage curve, thus allowing maximum utilization of the motor and, at the same time, fully protecting the motor from damage. (The motor damage curve is defined as that point in the relationship of the motor current and time where thermal damage results.) When the motor current-versus-time relationship exceeds this damage curve, a trip condition occurs, and the main contactor opens.

The correct motor protection curve for a specific application will automatically be calculated by the IQ-2000 after the correct setpoint values are programmed for the full-load amps, maximum allowable locked-rotor current and stall time, and ultimate trip. A brief discussion of how these values affect the motor protection curve follows.

The typical curve shown in Figure 5.2 is the result of the factors listed in the following Paragraphs.

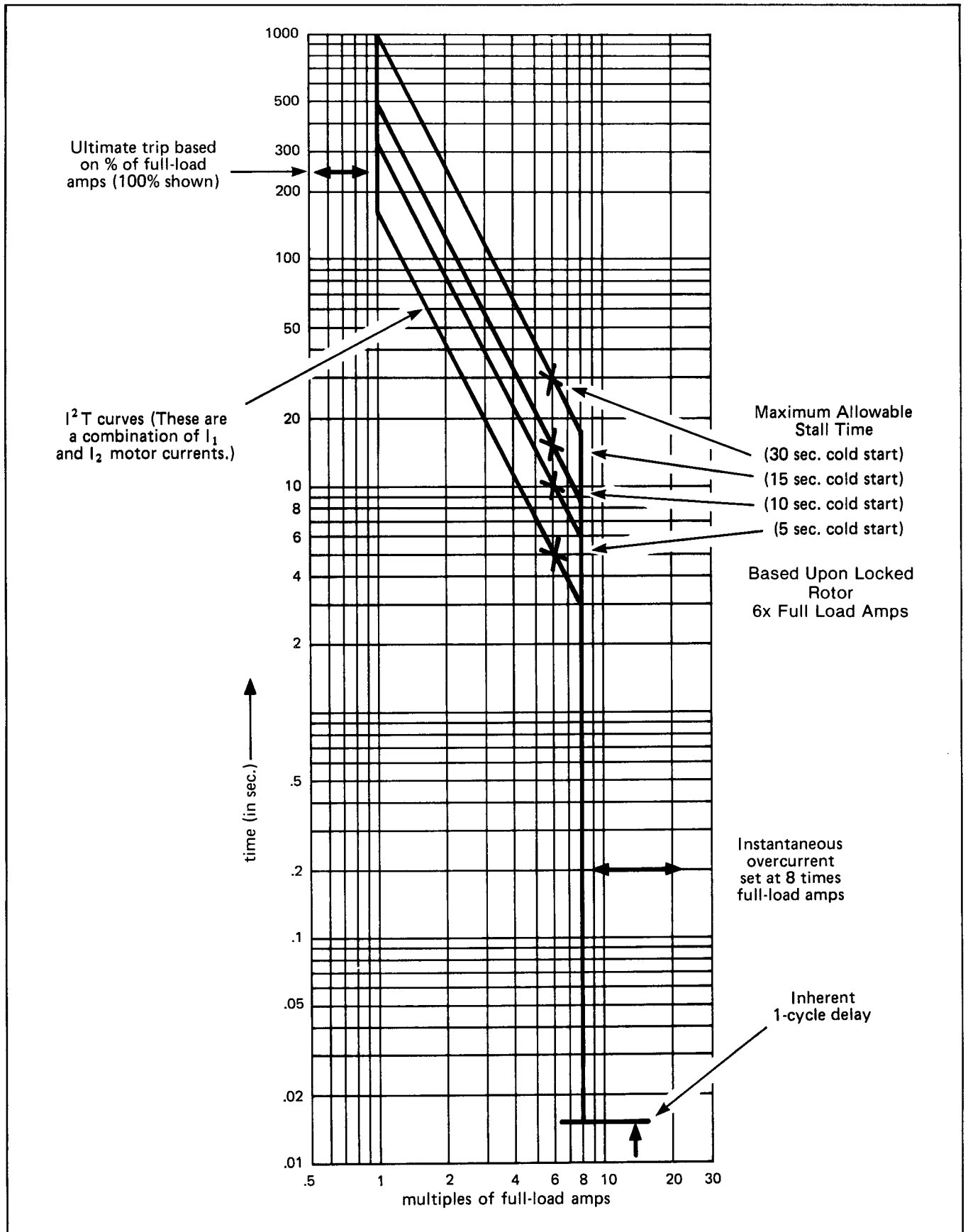

Figure 5.2 – Motor Protection Curve

5.1.3.1 Instantaneous Overcurrent — The instantaneous overcurrent in this sample figure is set at 8 times full-load amps. (The range may be 3 to 15.) Note that instantaneous overcurrent has an inherent 1-cycle delay to avoid nuisance tripping. This protective function overrides all other functions.

5.1.3.2 Allowable Locked-Rotor Current, Time — The curves shown on Figure 5.2 are based upon the maximum allowable locked-rotor current being 6 times full-load amps. The actual values can be greater or less as programmed into the IQ-2000. (The range may be 3 to 12 times.) All curves shown are based upon maximum allowable stall time with a cold start.

Since the IQ-2000 algorithm retains a history of the operating current and time of the motor, it is not necessary to program it for hot starts. The IQ-2000 automatically takes into consideration if it is a cold or hot start. Therefore, the stall time as based upon the cold start should be used in programming the IQ-2000.

5.1.3.3 Ultimate Trip — It is necessary to program the ultimate trip value. This would normally be set at 100% of full-load amps. If the motor has a service factor larger than 100% and it is decided to make use of this factor, this situation shifts the ultimate curve to the right on the time-current graph and has an effect where the I^2T curve intersects the ultimate trip curve.

Note that the I^2T curves are a combination of the positive current and negative sequence current, with the negative sequence current weighted to reflect the additional rotor heating it causes. (Figure 5.2 shows the curves that result from maximum stall times.)

5.1.3.4 Underload Function — When the motor is running, a sudden reduction of current below a programmed value for a programmed time would indicate a malfunction in the driven equipment, and an underload trip would be activated. (Refer to Figure 5.3.)

Shutdown protection is used in the event of mechanical problems such as a blocked flow in a pump, loss of back

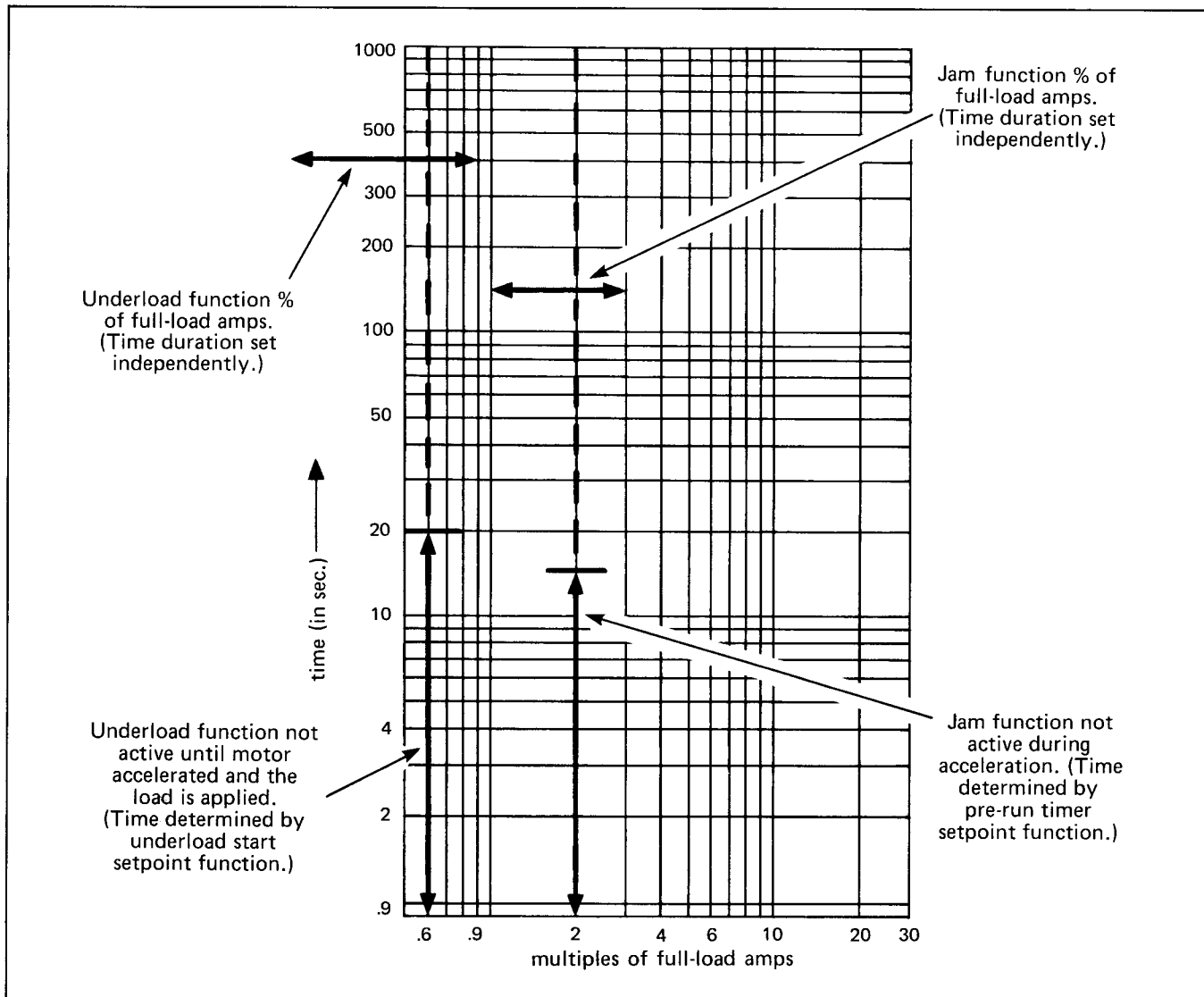

Figure 5.3 – Underload and Jam Protection

pressure in a pump, or a broken drive belt or drive shaft. A programmed lockout during a motor start cycle may occur if the load is not immediately applied. This is determined by the setpoint value of the underload start timer.

If this function is not required, the underload setpoint function should be set at 0. This function is not required to protect the motor but may be desirable to provide system protection.

5.1.3.5 Jam Function — Once the motor is running, if an instantaneous current exceeds a programmed value for a programmed time, a trip will occur. (See Figure 5.3 where the jam setpoint is set for 200% of full-load current.) This protection is desirable with gear train and other mechanical type loads where a physical jam could cause damage. The jam function is not active during acceleration; this permits locked-rotor current during acceleration. The locked-out time function is programmed by the time set of the pre-run timer. If this function is not required, the jam function should be set at 1200%. This function is not required for motor protection but may be desirable to provide system protection.

5.1.3.6 Temperature Effects — The motor protection function is affected by the calculated rotor temperature. Without RTDs, the temperature is assumed to be 40°C. Thus the actual ambient temperature has no effect on both the starting and running of the motor. The customer application engineer should take these factors into consideration and compensate for them if a higher ambient temperature is anticipated. The best solution is the use of RTDs, since any compensation for a higher ambient temperature results in overprotecting the motor during lower temperature conditions. Without RTDs, the IQ-2000 calculates the current and time and converts this to a calculated stator/rotor temperature. The constant I^2T curve, as established by the maximum allowable locked-rotor current and time, must be assumed to adequately protect the motor for all values of motor current above the ultimate trip value. Should the curve not be adequate to protect the motor due to stator limitations at elevated ambient conditions, then the use of RTDs is recommended. The use of RTDs allows a fuller utilization of the power available from the motor and reduces unnecessary shutdowns.

5.1.4 Typical Motor Protection Curves — To illustrate the effects of these protection features, 2 sample curves are shown. Using specific motor data, typical motor protection curves of the IQ-2000 are shown in Figure 5.4 without the use of RTDs. The use of RTDs is assumed in Figure 5.5. The following data was used:

- Instantaneous overcurrent 8 times full-load amps
- Maximum allowable locked-rotor amps 6 times full-load amps
- Maximum stall time 15 seconds, cold start
- Ultimate trip 100% of full-load amps
- Acceleration of motor loaded, 10 seconds
- Motor running loaded at 90% of full-load amps

- Underload protection set at 60% of full-load amps for a 5-second duration
- Jam protection 180% full-load amps for a 5-second duration

The basic difference with the addition of RTDs is shown in Figure 5.5 in the time period after 60 seconds. With RTDs, the actual monitored temperature automatically overrides the ultimate trip setting of the IQ-2000. It should be noted that the ambient conditions that the motor is operating under will affect the top portion of the curve. The curve is shifted to the left with increasing ambient temperature, and to the right for decreasing temperature.

The effects of the motor winding temperature setpoint value which is available when RTDs are used are not evident in Figure 5.5. This setting is independent of the effects of temperature on the algorithm trip curve. The setting is based upon the recommended maximum temperature as supplied by the motor manufacturer. Depending upon the specific setting, the temperature trip curve would be to the left of the motor protection RTD algorithm.

The IQ-2000 allows maximum utilization of the power available from the motor by setting its trip conditions as close as possible to the motor damage curve.

5.1.5 Motor Current — The negative sequence and positive sequence motor currents are both monitored by the IQ-2000.

5.1.5.1 Negative Sequence Currents — Throughout the discussion of the motor protection curves, the effects of negative sequence currents cannot be emphasized too strongly. For maximum motor utilization, the actual load should be matched closely to the full horsepower of the motor. However when this is done, the effect of motor voltage unbalance—that is, the negative sequence current—becomes more critical. The IQ-2000 accurately calculates negative sequence currents on an on-going basis. It is not necessary to arbitrarily pick a specific percent unbalance to shut the motor down. As long as the rotor temperature as calculated by the IQ-2000 does not equal the motor damage curve, the motor will be allowed to operate.

5.1.5.2 Positive Sequence Currents — True RMS motor current is monitored. A total of 36 samples are taken in each phase during a 12-cycle period to calculate the positive and negative sequence currents. The sample point is constantly shifting; thus the IQ-2000 will also monitor non-sinusoidal wave forms. This is important for applications where power factor correction capacitors and rectified systems are on the same main bus.

5.2 Motor Control — The term motor control refers to the starting and stopping of a motor as controlled by the IQ-2000. In addition to precisely controlling the contactors, auxiliary functions are also sequenced on and off. The explanation here centers on the control features associated with starting and stopping a motor.

5.2.1 Motor Starting — When starting a motor, it is often desirable to control auxiliary functions such as coolant

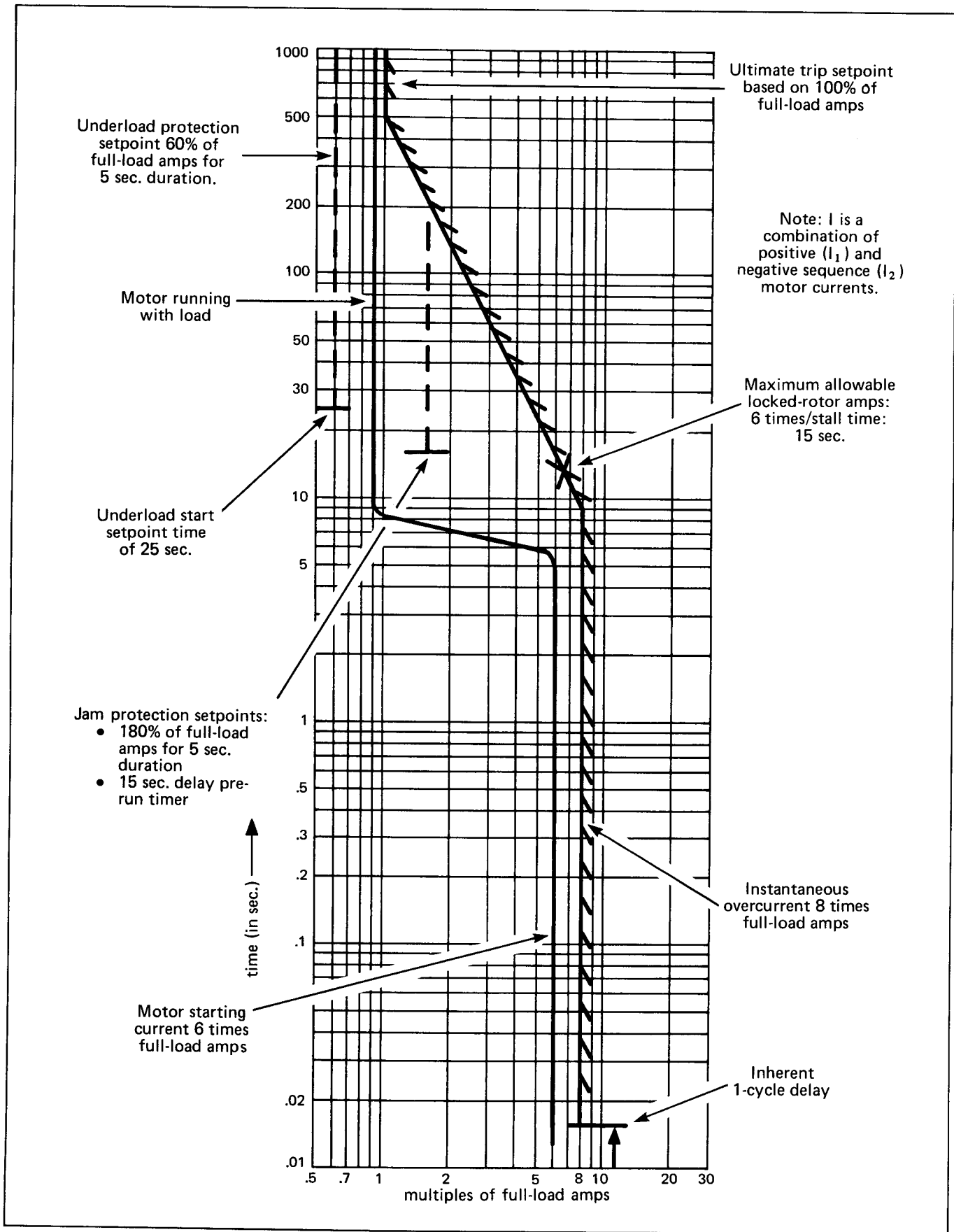

Figure 5.4 – Motor Protection Curve (without RTDs)

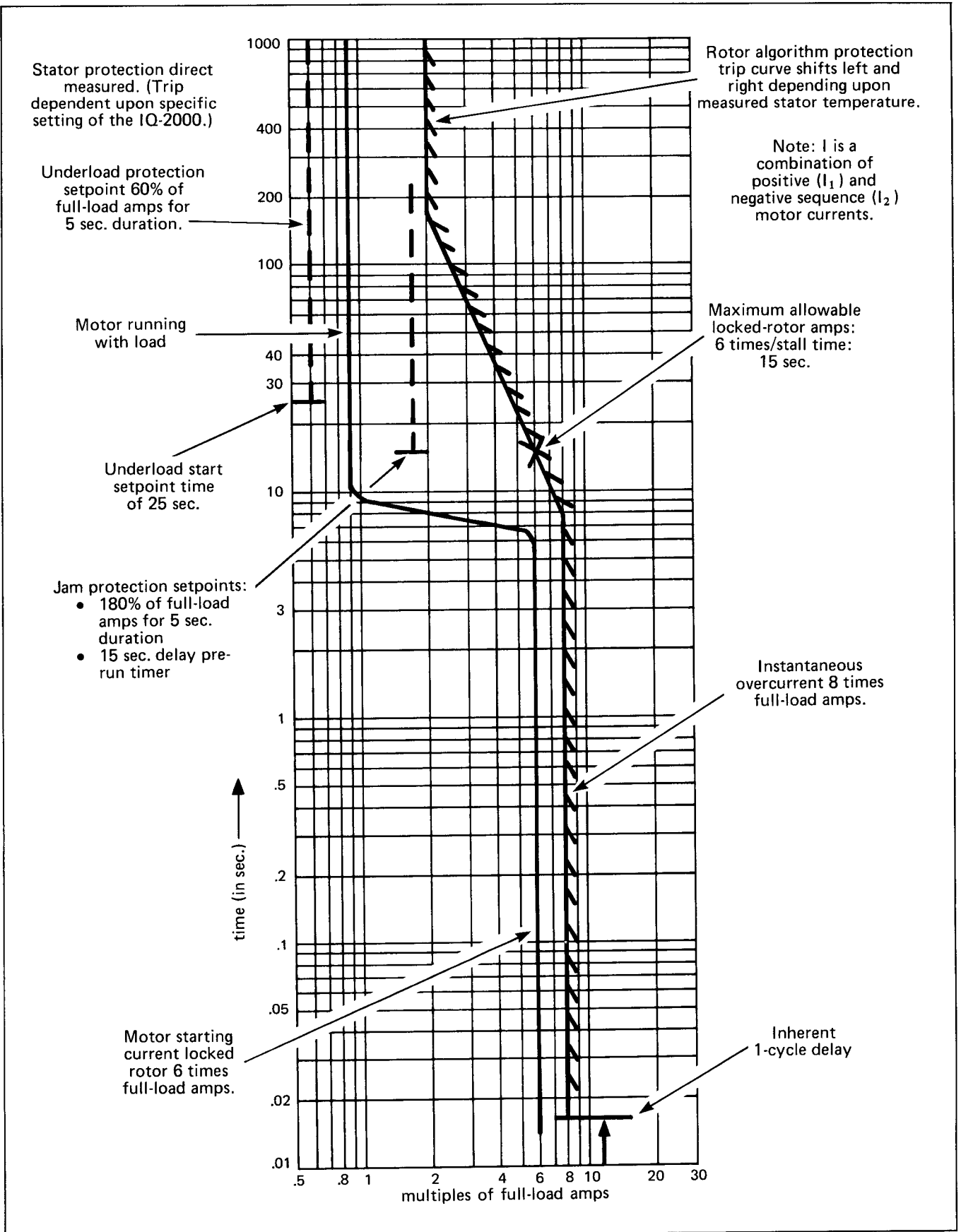

Figure 5.5 – Motor Protection Curve (with RTDs)

pumps, louvers or valves in coordination with the sequencing of the main motor contactor. Equally desirable is the ability to delay the enabling or disabling of the contactor until receiving a feedback signal. In this manual the signal is called a "report-back." The IQ-2000 allows the application engineer to select and program the following related setpoints:

- Pre-start timing
- Post-start timing
- Pre-run timing
- Incomplete sequence timing

The relationships among the timing functions, the contactor(s) and the feedback signals during the start cycle are shown in Figure 5.6. Note the following:

- The entire start cycle is initiated by a start command—such as when the FWD/SLOW FWD-MOM terminal (TB-A10) is energized. (See Figure 3.6.) Note that other input signals may also initiate the start cycle. (See Paragraph 5.4.1.)
- Upon actuating the start command, the Pre-start Relay's output contacts B1-B2 close.
- When the pre-start timer output contacts are energized, the message PRE-START is displayed in the FUNCTION window.
- The PRE-START REPORT-BACK terminal (TB-A9) must be energized **before** a start sequence continues. Note, however, that the pre-start timer setpoint function can be disabled if it is not required. (See Paragraph 6.14.)
- If the pre-start timer function times out **before** the PRE-START REPORT-BACK terminal (TB-A9) is energized, the starting cycle is aborted. At this time the message BAD START RESET is displayed in the FUNCTION window.
- In a multi-step application where, for example, the Class 11-502 is used, the momentary contactor is closed for a time determined by the pre-run setpoint function. (It is programmable from 0 to 60 seconds.) Even if the application is for an across-the-line starter, the pre-run timer is used. (See Paragraph 6.15.)
- When the PRE-START TIMER REPORT-BACK terminal is energized, the message START SEQUENCE is displayed in the FUNCTION window.
- After the time duration is set on the pre-run timer, the contactors are shifted to a run configuration. Even if the starter is an across-the-line starter, this timer function is still used. (See Paragraph 6.15.)
- At this time, the completion of the pre-run timing sequence, the message RUN SEQUENCE is displayed in the FUNCTION window.
- After the run sequence is established, the post-start timing sequence starts.

- Only after the post-start timer function times out is the Post-start Relay energized. It remains energized until after the stop sequence becomes active. The function is programmable from 0 to 60 seconds. Contacts from this Relay may be used for auxiliary control functions such as enabling a load or, in stepping or process type applications, enabling the next sequence or step in the process.
- The incomplete sequence timing function causes a trip condition if the INCOMPL SEQ REPORT-BACK terminal (TB-A13) is not energized before this timing function is complete. The trip stops the motor. Note, however, that the incomplete sequence function can be disabled if it is not required. (See Paragraph 6.17.)

5.2.2 Long Acceleration Starting — There are some applications where the acceleration time exceeds the stall time. The IQ-2000 eliminates the necessity of choosing to start the load with the motor unprotected, or to protect against locked rotor. Initially the motor manufacturer must confirm that the motor is capable of starting the load. The long acceleration function works as follows: when the motor is started, locked-rotor protection is in effect. The IQ-2000 projects the temperature of the rotor, and, if it exceeds the trip value, shuts down the motor. If the motor starts to move the load, then the rotor starts to self cool. A zero-speed switch is required to allow the IQ-2000 to go into the long acceleration mode. (This is wired to L ACCEL PERM, TB-A11.) In this mode the IQ-2000 presets the rotor temperature storage to a value one count below the trip condition setpoint value. If, at the end of the long acceleration time, the current is reduced to a value such that the rotor protection algorithm is decreasing the value of the rotor temperature storage, the motor is allowed to continue to rotate. If the rotor temperature storage is still increasing, the IQ-2000 goes immediately into a trip condition.

5.2.3 Motor Stopping — When stopping a motor, it is often desirable to be able to control auxiliary functions such as pumps, louvers or valves in coordination with the main contactor(s). The following setpoint functions may be selected by the engineer and programmed as required by the individual application:

- Pre-stop timer
- Post-stop timer
- Anti-backspin timer
- Anti-recycle

The relationships among the timing functions and the de-energizing of the contactor(s) is shown in Figure 5.7. Note the following:

- The motor's stop cycle is initiated when the RUN ENABLE terminal (TB-A8) is de-energized. This initiates the pre-stop timer function. Note that the motor's stop cycle can also be initiated by any trip condition including instantaneous overcurrent, over-voltage, etc.

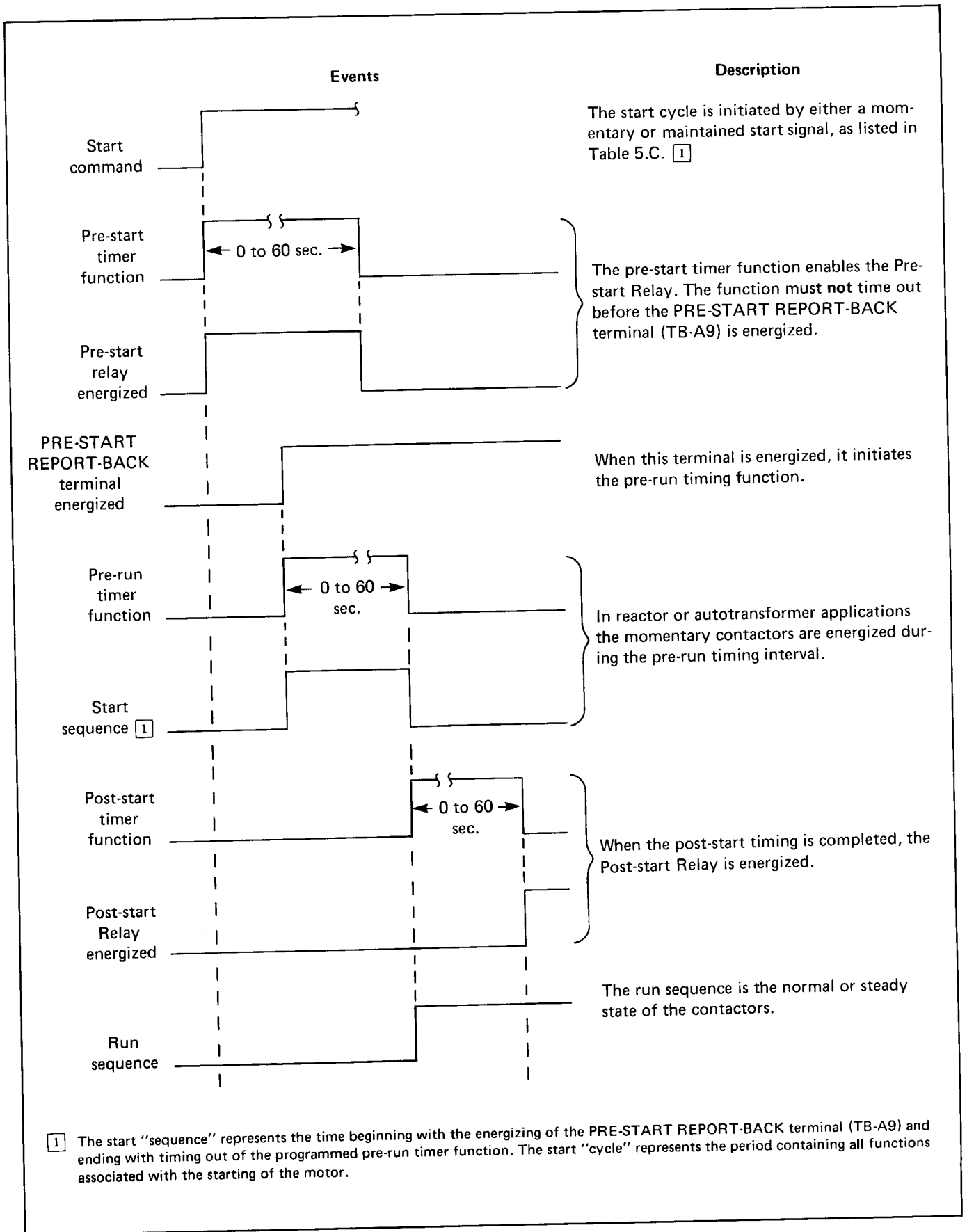

Figure 5.6 – Motor Start Cycle Events Diagram

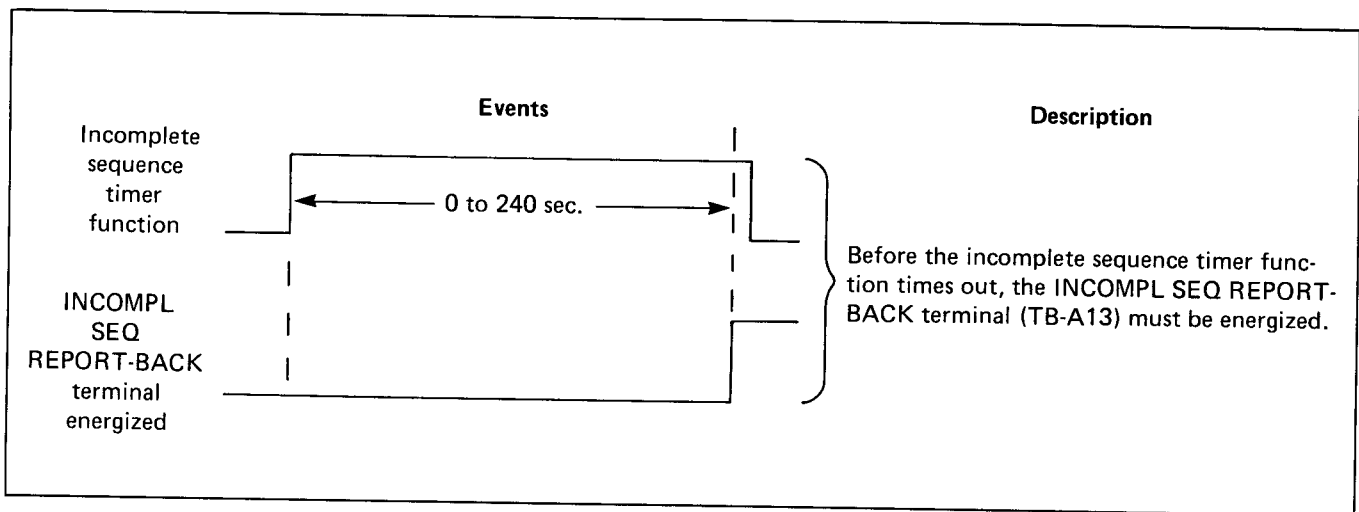

Figure 5.6 -- (Cont'd.)

- The stop sequence, which de-energizes the contactor, is initiated when both the PRE-STOP REPORT-BACK terminal (TB-A7) is energized and the pre-stop timing function is active. If the terminal is not energized before the pre-stop timer function has timed out, a stop condition occurs. Also, the message BAD STOP RESET is displayed in the FUNCTION window.

Note, however, that the pre-stop timing function can be disabled if it is not required by the application. (See Paragraph 6.16.)

- After the stop sequence is complete, the post-stop timing function is enabled. It is programmable from 0 to 60 seconds.
- A Pre-stop Relay is energized when the pre-stop timer setpoint function is active. It may be used to control auxiliary functions such as turning off cooling pumps, etc.
- The Post-stop Relay is energized while the post-stop timing function is active. Typically, it is used to control such auxiliary functions as disabling a load or, in stepping or process controls, to disable the next sequence or function in the process.
- The anti-backspin timer function prevents the initiation of a new start cycle until the programmed duration has timed out. It is assumed that during the programmed duration between 0 and 240 seconds the motor's reverse rotation will come to a full stop. Note, however, that the anti-backspin timer function can be disabled if it is not required. (See Paragraph 6.18.)
- The anti-recycle prevents a motor restart for the period of time programmed in minutes. It prevents restarting of the motor whether or not the start cycle was completed. Its timing function starts at the beginning of the motor run sequence.

5.3 AC Line Interruptions – The IQ-2000 is designed to operate in a controlled and predictable manner during incoming AC line interruptions. The events flow chart shown in Figure 5.8 lists the predictable events which occur during various AC line interrupts. The chart assumes a complete, or nearly complete, loss of AC power.

(For situations where AC power is low but present, refer to Paragraph 6.20, undervoltage setpoint function.)

5.4 Control Signal Wiring – The IQ-2000 communicates with the motor, contactor and associated machine or process through the following:

- Sensing inputs from the ground, current and optional potential transformers supplied by Westinghouse and, if used, shown on the Ampgard schematic.
- Discrete inputs from devices such as pushbuttons or relay contacts.
- Outputs in the form of relay contacts from the IQ-2000. (These include the Post-stop and Pre-stop Relays.)
- Outputs in the form of contacts of the main contactor and interlock contacts.

5.4.1 Discrete Inputs – The discrete input terminals are designed to receive 120 VAC from such devices as switches, pushbuttons, relay contacts, etc. (The majority of these are on TB-A. See Figure 3.6.) The characteristics of these input circuits are listed in Table 5.A. The control step-down transformer supplying 120 VAC is shown on the Ampgard schematic.

A description of each discrete input is shown in Table 5.B. Note that the inputs used for motion control are further described in Table 5.C. Depending on the specific starter class, these contacts can initiate movements indicated in the table.

Momentary contacts **must** remain closed for a minimum time of 17 cycles in order to be sensed by the IQ-2000.

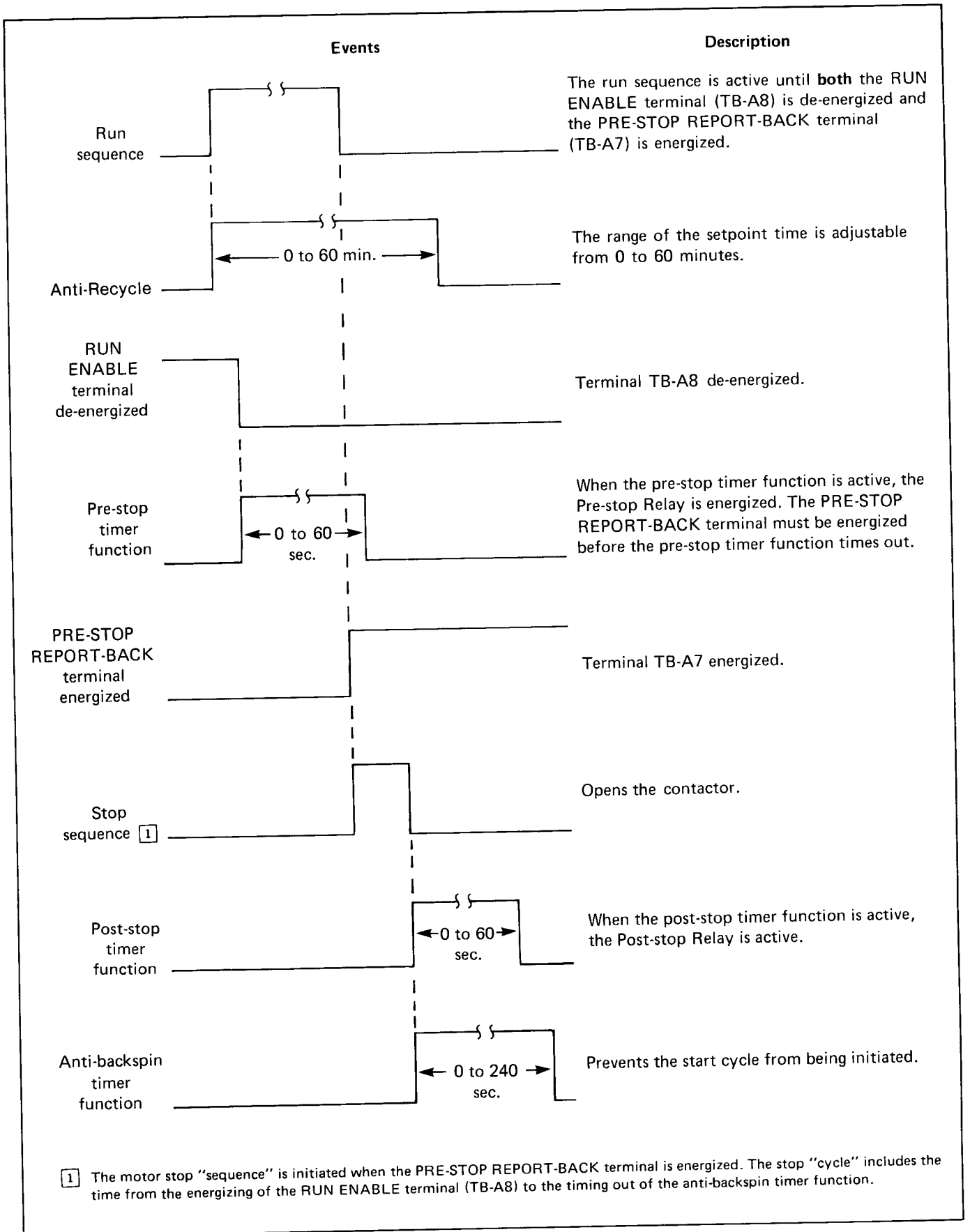

Figure 5.7 – Motor Stop Cycle Events Diagram

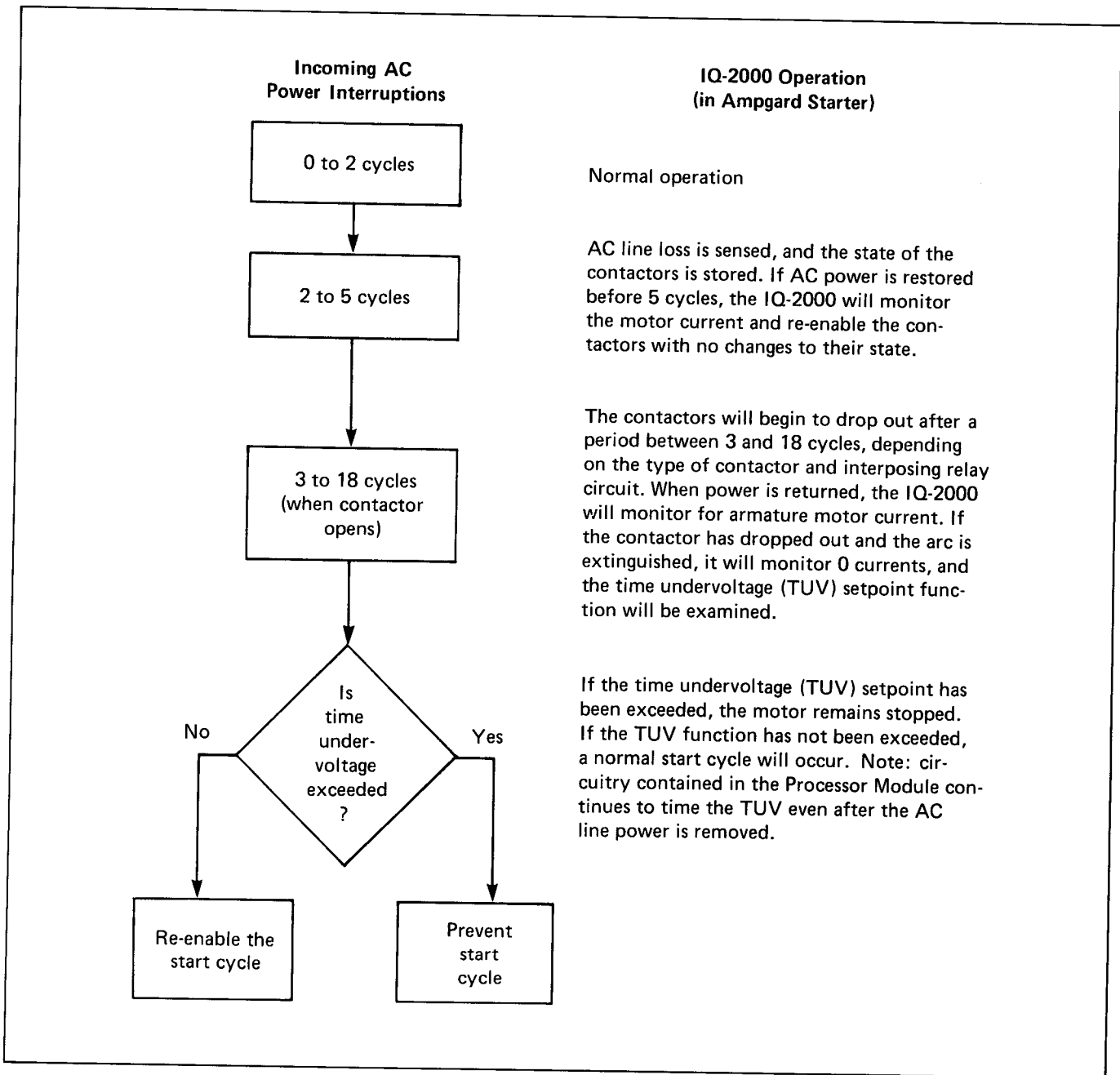

Figure 5.8 – AC Interrupt Events Flow Chart

5.4.2 Output Contacts – The IQ-2000’s output contacts can in general be divided into the following groups:

- Relays C1 thru C4, which are contained on the Processor Module. These are pre-wired by Westinghouse to the interposing relays contained on the draw-out panel.
- Spare interposing relay interlock contacts. These are wired to the machine or processed through the TB terminal block as shown on the Ampgard Schematic for each IQ-2000.

Table 5.A

INPUT CIRCUIT CHARACTERISTICS

Characteristic	Specification
Opto isolation	1500 volts
Input impedance	26K ohms
Input current drain (ON)	4.5 mA
Input current drain (OFF, max.)	1.0 mA

These contacts are rated for 120 VAC at 10 amperes, or 28 VDC at 6 amperes.

- Miscellaneous control function relay contacts such as the Pre-start Relay's Form C contacts. A complete list of these is shown in Table 5.D.

These contacts are rated for 120 VAC at 10 amperes, or 28 VDC at 6 amperes.

5.5 Wiring Considerations – A suitable wiring plan that shows the interconnection between the IQ-2000 and the

associated machine or process must be developed. This paragraph contains general guidelines to be followed by the application engineer who is developing a specific wiring plan. The Ampgard Schematic developed by Westinghouse for each unique application shows the interconnection between the IQ-2000 and the Ampgard Starter. It also defines which control inputs and outputs are available. (Refer to Figure 3.1 which shows a **typical** Ampgard Schematic.) All wiring must be in conformance with the National Electrical Code as well as any other applicable state and/or local codes.

Table 5.B
INPUT TERMINAL DESCRIPTION

Terminal	Designation	Description
TB-A2	EMER STOP	Hard-wired to the lock-out stop/reset switch. It is used to inform the IQ-2000 when a lock-out stop is initiated.
TB-A3	FAST FWD- MAINT.	See Table 5.C for a description of the input terminal functions as they relate to the various starter types.
TB-A4	RVS/SLOW RVS-MOM	
TB-A5	FWD/SLOW FWD-MAINT.	
TB-A6	RVS/SLOW RVS-MAINT.	
TB-A7	PRE-STOP REPORT- BACK	Optionally used during the motor stop cycle to enable the stop sequence. Requires 120 VAC signal to enable. (See Par. 5.2.3 for details.)
TB-A8	RUN ENABLE	Must be energized to allow the start cycle. If de-energized, the stop cycle will be initiated.
TB-A9	PRE-START REPORT- BACK	Optionally used during the start cycle to enable the start sequence. Requires 120 VAC to signal enable. (See Par. 5.2.1 for details.)
TB-A10	FWD/SLOW FWD-MOM	See Table 5.C for a description of the input terminal functions as they relate to the various starter types.
TB-A12	FAST FWD- MOM	
TB-A11	L ACCEL PERM	Optionally used during the start cycle. (See Par. 6.7.)
TB-A13	INCOMPL SEQ REPORT- BACK	Optionally used during the motor starting sequence. If the incomplete sequence timing function is completed before this terminal is energized, the stop cycle is initiated. (See Par. 5.2.1 for details.)
TB-A14	REMOTE TRIP	When energized with 120 VAC, the stop cycle is initiated, and REMOTE TRIP will be displayed in the FUNCTION window of the Operator Panel.

5.5.1 RTD Wiring – If the optional RTD Module is used, it must be wired as shown in Figure 5.9. Also, note the following requirements:

- Use 10-ohm copper, 100-ohm platinum, or 120-ohm nickel RTD device. The RTD type must be specified at the time of order.
- Use AWG No. 18 3-conductor, stranded, twisted, copper wires, such as Belden No. 8770, or equivalent.
- At the RTD, 2 return lines must be wired together, as shown in Figure 5.9.
- In cases where the motor provides only 2 leads from the RTD, connect 2 of the 3 conductor wires together at one of the leads. Make this connection as close to the RTDs as possible.
- The cable's shield drain wire must be connected to the appropriate terminal on the RTD Module. At the opposite end cut the shield and drain wire short, and tape them to prevent shorts. Do not connect these at the RTD device end.

- In cases where one or more of the 10 possible RTDs is/are not used, there is no need to make any jumper connections on the RTD Module's terminal.

An RTD wiring diagram is shown in Figure 3.3.

5.5.2 Grounding – Observe these guidelines when planning grounding.

- It is necessary to place a suitable grounding electrode between the earth ground electrode (or plant ground bus) and the Ampgard ground stud.
- The sizing and type of insulation for the AC supply line and grounding electrode conductor must be in conformance with the National Electrical Code.

A typical grounding plan is shown in Figure 3.5.

5.5.3 Wire Routing – Wire routing is divided into 2 types: high-voltage (440 VAC and higher) and low-voltage (120 VAC and VDC signals). Low-voltage tends to be control and RTD wiring. Note the following guidelines when developing a wire plan:

Table 5.C
MOMENTARY AND MAINTAINED INPUT TERMINALS

		Starter Types/Input Terminal Function ¹					
Input ² Terminal	Designation ³	11-202 13-202 14-202	11-212 13-212 14-212	11-502 14-502 11-602	11-512 14-512 11-612	11-902	11-912
TB-A5	FWD/SLOW FWD-MAINT.	Forward	Forward	Forward	Forward	Slow Forward	Slow Forward
TB-A6	RVS/SLOW RVS-MAINT.	-	Reverse	-	Reverse	-	Slow Reverse
TB-A3	FAST FWD- MAINT.	-	-	-	-	Fast Forward	Fast Forward
TB-A10	FWD/SLOW FWD-MOM	Forward	Forward	Forward	Forward	Slow Forward	Slow Forward
TB-A4	RVS/SLOW RVS-MOM	-	Reverse	-	Reverse	-	Slow Reverse
TB-A12	FAST FWD- MOM	-	-	-	-	Fast Forward	Fast Forward

¹ See Par. 6.28 for a description of starter classes.

² Momentary contacts must be closed for a minimum of 17 cycles to insure the command's acceptance.

³ When a maintained-start input initiates the start cycle, the stop cycle is subsequently initiated when the maintained input is de-energized.

When a momentary start input initiates the start cycle, the stop cycle must subsequently be initiated when the RUN ENABLE terminal (TB-A8) is de-energized.

- **Separation.** Maintain a separation of at least 1-1/2 to 2 ft. (45 to 60 cm) between high- and low-voltage conductors. **Never** route high- and low-voltage lines in the same raceway.
- **Low-Voltage Lines.** It is necessary to route the draw-out panel's low-voltage wiring so that it loops behind the panel when it is closed. (See Paragraph 3.3.1.)
- **High-voltage Compartment.** **Never** route low-voltage wires through the high-voltage compartment. If, in extreme cases, it is necessary to do so, contact

Westinghouse Control Division for information.

5.6 Environmental Considerations — Consideration must be given to the actual location of the Ampgard/IQ-2000 enclosure in the plant. The Ampgard's operating ambient temperature range varies among applications. The IQ-2000 operates in a range between 0° and 55°C (32° to 131°).

The IQ-2000's circuit boards are spray-coated to withstand environmental contaminants. However, special precautions may be required for extremely dirty or corrosive environments. (Consult Westinghouse Control Division's applications department.)

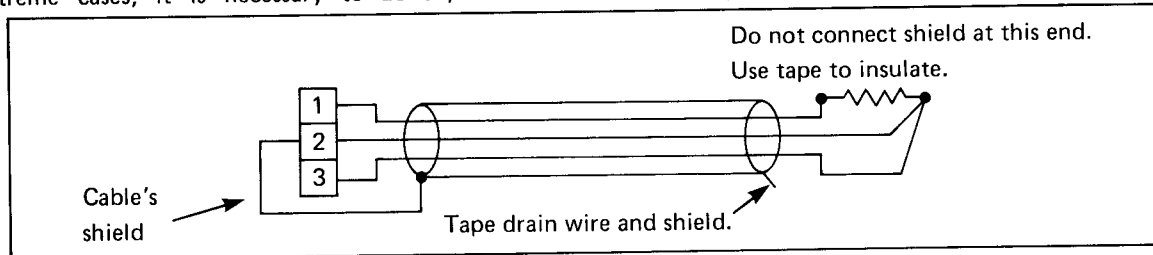

Figure 5.9 – RTD Wiring

Table 5.D

CONTROL FUNCTION RELAY CONTACTS

Terminal	Function	Designation	Description
TB-B1 TB-B2 TB-B3		Pre-start	The Pre-start Relay is energized when the pre-start timing function is active. (See Par. 5.2.1.)
TB-B4 TB-B5 TB-B6		Pre-stop	The Pre-stop Relay is energized when the pre-stop timing function is active. (See Par. 5.2.3.)
TB-B10 TB-B11 TB-B12		Alarm	The Alarm Relay is energized when any alarm condition—such as would occur when the programmed motor bearing temperature alarm setpoint value—is exceeded.
TB-B13 TB-B14 TB-B15		Trip ¹	The Trip Relay is actuated when any trip condition—such as would occur when the programmed winding temperature trip setpoint value is exceeded—occurs.
TB-C1 TB-C2 TB-C3		Post-start	The Post-start Relay is energized after the post-start timing function is timed out (See Par. 5.2.1.)
TB-C4 TB-C5 TB-C6		Post-stop	The Post-stop Relay is energized when the post-stop timing function is active. (See Par. 5.2.3.)
TB-D21 TB-D22		E-stop ¹	The Emergency Stop Relays normally open contacts are closed during normal running conditions.

¹ The contacts of the Emergency Stop Relay D21-D22 and the Trip Relay B13-B14-B15 are fail safe. They change position when power is applied. They drop open upon loss of power or trip condition.

Section 6

SETPOINT VALUE CONSIDERATIONS

6.0 General – This Chapter contains information needed by an application engineer to organize the setpoint values for a specific IQ-2000 so that they may be easily entered. Twenty-eight separate functions are provided. (See Table 6.A which summarizes them and acts as a quick locator.) Since many of the functions have more than one associated value, it is strongly recommended that **all** the setpoints be established and verified **before** any entry is begun. To this end, a Setpoint Record Sheet is included here to act as a permanent record of the setpoint values. (See Table 6.B.) Copies of it can be made and stored in a number of locations, including the enclosure.

Not all setpoint functions or values may be required by a given IQ-2000. In such cases, perform one of the following:

- Place N/A or some other notation in the space if the value has no effect on operation. (For example, winding temperature when there is no RTD Module.)
- Write in the value—which is usually zero—required to disable the function. (If functions must be disabled, specific instructions are given in the following paragraphs.)

Those setpoint functions involving both the trip and alarm setpoint values will usually be different; however, they can be identical if the application requires it.

Note that the VALUES window does not provide a decimal point, as such. However, a solid line at the bottom of the display takes its place.

A copy of a correctly filled-in Setpoint Record Sheet must be given to the individual responsible for value entry. The IQ-2000 displays its setpoint functions in a fixed sequence that is duplicated on the Setpoint Record Sheet. Thus the sheet minimizes programming time. (Specific entry procedures are described in Paragraph 4.3.2.)

Each of the 28 setpoint functions is described separately in the following paragraphs.

To easily understand the timing functions explained between Paragraph 6.14 and 6.22, refer to Figure 5.6 where various timing diagrams of the motor starting events are shown in a consolidated form.

6.1 Winding Temperature – Only when the optional RTD Module is used in the IQ-2000 is the winding temperature function used. It provides the control with the ability to monitor the temperature of a motor’s stator windings. The

Table 6.A

SETPOINT FUNCTION INDEX 1

Setpoint Function	Par.	Page
Winding temperature	6.1	40
Motor bearing temperature	6.2	41
Load bearing temperature	6.3	41
Ground fault	6.4	41
Instantaneous overcurrent	6.5	41
Locked rotor current	6.6	41
Long acceleration	6.7	41
Jam	6.8	44
Underload start	6.9	44
Underload run	6.10	44
Ultimate trip	6.11	45
Overvoltage	6.12	45
Undervoltage	6.13	45
Pre-start timer	6.14	45
Pre-run timer	6.15	46
Pre-stop timer	6.16	46
Incomplete sequence	6.17	48
Anti-backspin	6.18	48
Anti-recycle, minutes	6.19	48
Time undervoltage	6.20	49
Post-start timer	6.21	49
Post-stop timer	6.22	49
Start counts/hours	6.23	50
Open/unbalance phase	6.24	50
Full-load current	6.25	50
Current transformer ratio	6.26	51
Potential transformer ratio	6.27	51
Starter class	6.28	52

1 See Table 6.B for programming information.

resulting information is used in determining the motor protection curve.

Individual setpoint values may be entered for both trip and alarm conditions. The function is displayed as WINDING TEMP.

The ranges of values are:

- Trip: 0° to 199°C
(in 1° increments)
- Alarm: 0° to 199°C
(in 1° increments)

6.2 Motor Bearing Temperature – Only when the optional RTD Module is used and when motor bearing RTDs are supplied is the motor bearing temperature setpoint function used. It provides the control with the ability to monitor the temperature of the bearings.

Setpoint values may be entered for both trip and alarm conditions. The function is displayed as MOTOR BGR TEMP.

The ranges of values are:

- Trip: 0° to 199°C
(in 1°C increments)
- Alarm: 0° to 199°C
(in 1°C increments)

6.3 Load Bearing Temperature – Only when the optional RTD Module is used and when the load bearing RTDs are supplied is the load bearing setpoint temperature function used. It provides the control with the ability to monitor the temperature of the load bearings.

Setpoint values may be entered for both trip and alarm conditions. The function is displayed as LOAD BGR TEMP.

The ranges of values are:

- Trip: 0° to 199°C
(in 1°C increments)
- Alarm: 0° to 199°C
(in 1°C increments)

Note: when the RTD Module is installed but no external connections are made to it, the IQ-2000 functions properly even without RTD data at the open terminals. The same is true of cases where some of the terminals are unused.

6.4 Ground Fault – The ground fault setpoint function monitors the ground leakage current and compares it with user-programmed setpoints for both amount and time. The ground fault protection function requires a ground fault (zero sequence) transformer be installed in a grounded system where the secondary of main power transformer feeding the motor is wired in a wye grounded configuration.

Setpoint values may be entered for trip, alarm and time conditions. The function is displayed as GROUND FAULT.

The ranges of values are:

- Trip: 4 to 12 amperes
(in 1 amp increments)
- Alarm: 0 to 12 amperes
(in 1 amp increments)

- Time: 0 to 5 seconds
(in 1 sec. increments)

6.5 Instantaneous Overcurrent – The instantaneous overcurrent setpoint function provides the IQ-2000 with the ability to monitor motor current on a continuous basis. A trip condition is initiated when the actual current exceeds the programmed setpoint. A one-cycle “lockout” prevents nuisance trips because the control responds only after the second AC cycle when an overcurrent occurs.

A setpoint value may be entered only for a trip condition. The function is displayed as INST OVERCURRENT.

The available value range is:

- Trip: 300 to 1500% of full-load amperes
(in 100% increments)

Note that only the digits 3 thru 15 are used to represent 300 thru 1500.

6.6 Locked Rotor Current – The locked rotor current setpoint function defines the amount of current and time that initiate a trip condition.

Setpoint values may be entered for trip and time conditions. The function is displayed as LOCKED ROTOR CUR.

The ranges of values are:

- Trip: 300 to 1200%
(in 10% increments)
- Time: 1 to 60 seconds
(in 1 sec. increments)

Note that only the 3_0 thru 12_0 are shown on the display. A dash at the bottom between the numbers represents the trip range of 300 to 1200%. Also, these programmed values are used by the rotor temperature protection algorithm, as described in Paragraph 5.1.

Note that the maximum allowable stall current and time values **must** be obtained from the motor manufacturer.

CAUTION

The rotor temperature protection algorithm uses the maximum allowable locked-rotor current and time values to calculate the rotor temperature protection curve. Incorrect setpoint values can result in excessive rotor temperatures and motor damage.

6.7 Long Acceleration – The long acceleration setpoint function provides extended motor acceleration periods as may be necessary with certain motors where the allowable stall time is less than the normal acceleration time.

The function disables the motor temperature accumulator for the time value programmed. When this time elapses, the accumulator is loaded with a count of 1 less than the maximum value which will initiate a trip condition. When timed out, the accumulator is allowed to operate normally; that is, if the rotor’s temperature continues to increase, a trip condition occurs. An example of this is a condition of

Table 6.B
SETPOINT RECORD SHEET

					Ampgard Schematic No.: (drawing number) _____
Plant Designation: _____		End User: _____		Motor Designation: _____	
Plant Location: _____		OEM: _____		Motor Model No.: _____	
	Setpoint Function	Trip ¹	Alarm ²	Time ³	Setpoint Value Ranges
1	WINDING TEMP ⁴				Trip & alarm: 0° to 199°C (1°C incre.)
2	MOTOR BGR TEMP ⁴				Trip & alarm: 0° to 199°C (1°C incre.)
3	LOAD BGR TEMP ⁴				Trip & alarm: 0° to 199°C (1°C incre.)
4	GROUND FAULT				Trip: 4 to 12 amps (1 amp incre.) Alarm: 0 to 12 amps (1 amp incre.) Time: 0 to 5 sec. (1 sec. incre.)
5	INST OVERCURRENT				Trip: 300 to 1500% of full-load amperes (in 100% incre.) Use numbers 3 to 15 only.
6	LOCKED ROTOR CUR				Trip: 300 to 1200% (in 10% incre.) Use numbers 30 to 120 only. The decimal point here shown as: 3-0, 12-0) Time: 0 to 60 sec. (in 1 sec. incre.)
7	LONG ACCELERAT				Time: 0 to 99 sec. (in 1 sec. incre.)
8	JAM				Trip: 70 to 1200% of full-load amps (in 1% incre.) Use numbers 70 to 1200. Time: 0 to 5 sec. (in 1 sec. incre.)
9	UNDERLOAD START				Time: 0 to 25 sec. (in 1 sec. incre.) ⁵
10	UNDERLOAD RUN				Trip: 0 to 90% of full-load amps (in 1% incre.) Time: 0 to 10 sec. (in 1 sec. incre.)
11	ULTIMATE TRIP				Amp: 85 to 125% of full-load amps (in 1% incre.) ¹ Use numbers 85 to 125
12	OVERVOLTAGE ⁶				Trip: 0 to 9999 VAC (in 1 volt incre.) Time: 0 to 99 sec. (in 1 sec. incre.)
13	UNDERVOLTAGE ⁶				Trip: 0 to 9999 VAC (in 1 volt incre.) Time: 0 to 99 sec. (in 1 sec. incre.)
14	PRE-START TIMER				Time: 0 to 60 sec. (in 1 sec. incre.)
15	PRE-RUN TIMER				Time: 0 to 60 sec. (in 1 sec. incre.)
16	PRE-STOP TIMER				Time: 0 to 60 sec. (in 1 sec. incre.)
17	INCOMPL SEQUENCE				Time: 0 to 240 sec. (in 1 sec. incre.)
18	ANTI-BACKSPIN				Time: 0 to 240 sec. (in 1 sec. incre.)

(Cont'd.)

**Table 6.B
SETPOINT RECORD SHEET (Con't.)**

	Setpoint Function	Trip ¹	Alarm ²	Time ³	Setpoint Value Ranges
19	ANTI-RECYCLE, MIN				Time: 0 to 60 min. (in 1 min. incre.)
20	TIME UNDER VOLT				Time: 0 to 20 sec. (in 1 sec. incre.)
21	POST-START TIMER				Time: 0 to 60 sec. (in 1 sec. incre.)
22	POST-STOP TIMER				Time: 0 to 60 sec. (in 1 sec. incre.)
23	START COUNTS/HRS				Counts: 1 to 10 counts (in 1 count incre.) ¹ Time: 0 to 24 h4. (in 1 hr. incre.)
24	OPEN/UNBALANCE PHASE				Alarm: 5 to 30% of full-load amps (in 1% incre.) Time: 0 to 25 sec. (in 1 sec. incre.)
25	FULL LOAD CUR-A				Amp: 1 to 1000 (in 1 amp incre.) ³
26	C. T. RATIO				Ratio: 2, 4, 5, 8, 10, 15, 20, 30, 40, 50, 60, 80, 100, 120, 160, 200 (Where: 2 = 2:1, etc.) ³
27	P. T. RATIO				Ratio: 0, 2, 4, 5, 20, 30, 35, 40, 55, 60, 70 (Where: 4 = 4:1, etc.) ³
28	STARTER CLASS				Prefix in ALARM window: 11, 13, 14 Suffix in TIME window: 202, 212, 502, 512, 602, etc.

- ¹ Normally the TRIP window represents the setpoint value. However with the start count/hrs. function, it represents counts in hours. With the ultimate trip setpoint function, it represents % of full-load amps.
- ² Normally the ALARM window represents the setpoint value. However with the starter class function, it represents the 2-digit prefix of the class.
- ³ Normally the TIME window represents the setpoint value. However with the full-load current setpoint function, it represents current. With the control transformer and potential transformer functions, it represents a ratio. With the starter class, it represents the class suffix.
- ⁴ Unless the optional RTD Module is installed, setpoints will have no effect.
- ⁵ Although the underload start setpoint function involves a time value, it is entered with the underload run function. (See Paragraph 6.10.)
- ⁶ Unless the optional Potential Transformer is used, setpoints must be set at 0.

full-load current being too high. If there is no raising (incrementing) of the temperature accumulator, normal operation will continue.

Note that before this function may be used, the manufacturer **must** confirm that the motor is capable of starting a load over a period of time.

The available value range is:

- Time: 0 to 99 seconds
(in 1 sec. increments)

If this function is not used, zero **must** be entered as a time value. If the function is used, it must be initiated by a contact closure input to the L ACCEL PERM terminal (TB-A11). See Figure 6.1. The contact is typically an external zero-speed switch.

6.8 Jam — The jam setpoint function, active after the start cycle is completed, provides the control with the ability to initiate a trip condition if a jam occurs in the driven load. When the instantaneous current exceeds the current setpoint value for the time value specified, the trip is initiated. This function is used due to the system's limitations.

Setpoints may be entered for trip and time conditions. The function is displayed as JAM.

The ranges of values are:

- Trip: 70 to 1200% of full-load amperes
(in 1% increments)
- Time: 0 to 5 seconds
(in 1 sec. increments)

Note that in this case the numbers 70 thru 1200 are used.

If this function is not required, set the trip setpoint value above the maximum allowable locked-rotor current.

6.9 Underload Start — The underload start setpoint function "blocks," or disables, the underload run setpoint function from initiating a trip condition when starting a motor. The time period that the underload run trip is disabled is determined by this function's time setpoint value.

The available value range is:

- Time: 0 to 25 seconds
(in 1 sec. increments)

The trip value is not entered here.

If it is desired to disable the underload start trip function, program a zero for this value.

6.10 Underload Run — The underload run function initiates a trip condition **after** the start sequence if the actual

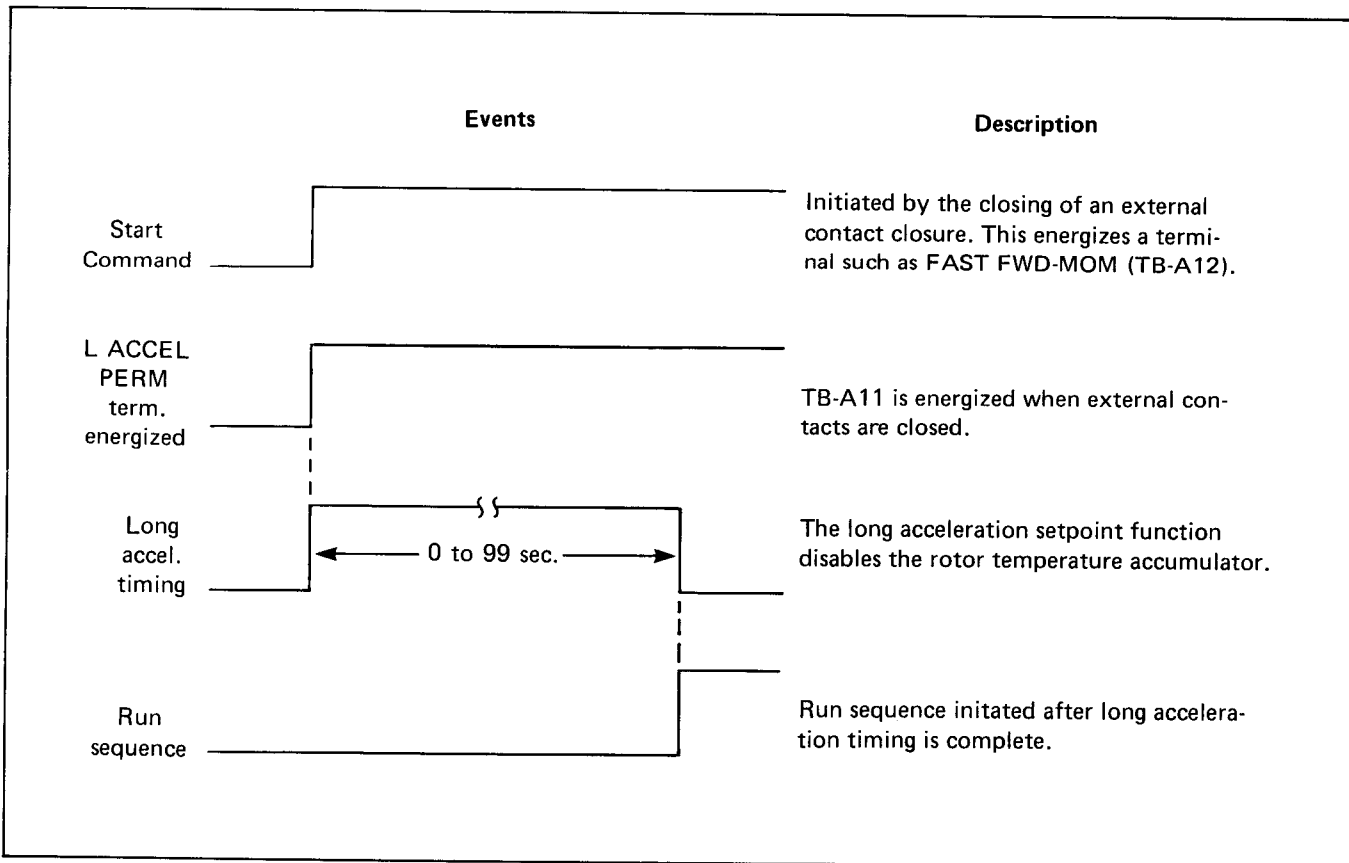

Figure 6.1 — Long Acceleration Events Diagram

motor current drops below the ampere trip level for the programmed time value. The trip value entered for this function directly affects the underload start trip value.

Setpoints may be entered for trip and time conditions. The function is displayed as UNDERLOAD RUN.

The ranges of values are:

- Trip: 0 to 90% of full-load amps
(in 1% increments)
- Time: 0 to 10 seconds
(in 1 sec. increments)

If it is desired to disable the underload run trip function, program a zero for the time value and set the trip value below 10%. This entry also disables the underload **start** function at the same time.

6.11 Ultimate Trip — The ultimate trip setpoint function defines a percent of full-load amperes that is allowed **before** a trip condition is initiated. In effect, this function modifies the motor's full-load ampere rating by a factor between 0.85 to 1.25. (See Paragraph 5.1.1 for details.) When this function's setpoint value is less than 100%, the permissible full-load ampere rating is less than 100%. Its setting selects the point where the I²T curve becomes asymptotic in cases where RTDs are **not** used.

Some possible reasons for a conservative approach where the ultimate trip is less than 100% are:

- When ambient temperatures above 40°C are anticipated and the optional RTD Module is **not** used in the application. (See Paragraph 5.1.3.6.)
- When the motor is properly rated, yet an additional safety factor is critical for the application

A setpoint for % of full-load amperes is entered in the TRIP window. The function is displayed as ULTIMATE TRIP.

The available value range is:

- Amps: 85 to 125% full-load amps
(in 1% increments)

In cases when a value from 101 to 125% is programmed, the permissible motor full-load amps will be greater than the programmed full-load current setpoint value. This can occur when the motor manufacturer's ultimate trip rating for the motor is above 100% of full-load amperes. The ultimate trip should be entered to correspond to the motor's service factor rating if service factor is to be utilized.

CAUTION

If the ultimate trip setpoint is set above 100% and the motor does not have a service factor rating higher than 1, motor damage can result.

6.12 Overvoltage — The overvoltage setpoint function initiates a trip condition if the incoming AC supply line voltage exceeds the programmed trip value for the programmed time.

The actual incoming AC supply voltage is reduced to 120 VAC by an optional potential transformer which monitors this voltage. If this transformer is **not** installed, the overvoltage function is automatically disabled regardless of programmed values.

Setpoints may be entered for trip and time conditions. The function is displayed as OVERVOLTAGE.

The ranges of values are:

- Trip: 0 to 9999 VAC
(in 1 volt increments)
- Time: 0 to 99 seconds
(in 1 sec. increments)

6.13 Undervoltage — The undervoltage setpoint function initiates a trip condition if the incoming AC supply line voltage drops below the programmed trip value for the programmed time.

The actual incoming AC supply line voltage is reduced to 120 VAC by an optional potential transformer which monitors this voltage. If this transformer is **not** installed, the undervoltage function is automatically disabled regardless of programmed values. Note: the IQ-2000 constantly monitors the incoming AC line. Regardless of the undervoltage setpoint, the motor will be stopped and the control will be automatically turned off when the line voltage drops below 30% of the normal rating.

Setpoints may be entered for trip and time conditions. The function is displayed as UNDERVOLTAGE.

The ranges of values are:

- Trip: 0 to 9999 VAC
(in 1 volt increments)
- Time: 0 to 99 seconds
(in 1 sec. increments)

Note: the undervoltage setpoint time must be set larger than the time delay undervoltage listed in Paragraph 6.20. If not, the undervoltage protection enters a trip and cannot be restarted without depressing the RESET pushbutton.

6.14 Pre-start Timer — The pre-start timer setpoint function, initiated at the beginning of a start cycle, provides a programmable period within which a report-back signal from a machine or process must be received at the PRE-START REPORT-BACK terminal (TB-A9). If the signal is not sensed within that time, the start cycle is aborted. This function provides a safety feature for auxiliary, but necessary, external events.

In terms of hardware, when a start command, such as the FWD/SLOW FWD-MAINT. at TB-A5 occurs, the IQ-2000's Pre-start Relay is energized, and its contacts close. It remains energized as long as the pre-start timer function is active. (See Figure 6.2 and 5.6.) These contacts may be used to enable external functions such as lube oil flow, cooling or priming pumps.

A setpoint may be entered for the time duration. The function is displayed as PRE-START TIMER. During a pre-start

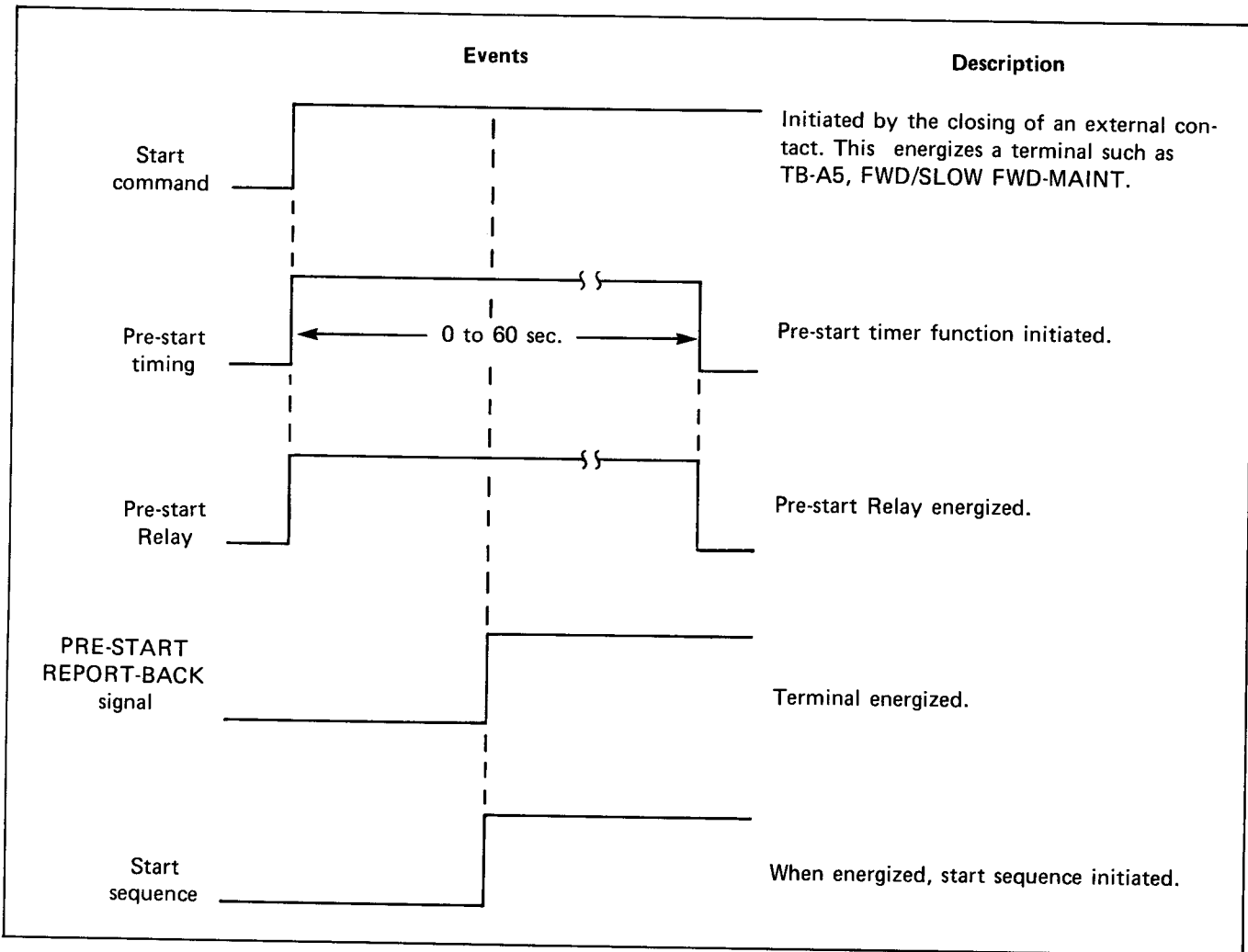

Figure 6.2 – Pre-start Events Diagram

condition in the run mode, this message also appears.

The available value range is:

- Time: 0 to 60 seconds (in 1 sec. increments)

In summary, the motor start sequence begins only when the following conditions exist:

- A pre-start timing function is active
- The PRE-START REPORT-BACK terminal (TB-A9) on the IQ-2000 is energized

If these preconditions do not exist, the pre-start timer function times out, the start sequence never begins, and the message BAD START RESET is displayed.

If it is desired to disable the pre-run timer function, program a zero for the time value. It is also necessary to disable the PRE-START REPORT-BACK terminal (TB-A9) in order to prevent the aborting of the start cycle unnecessarily. As shown in Figure 3.6, a jumper must be placed between the PRE-START REPORT-BACK terminal (TB-A9) and the available 120 VAC at TB-19.

6.15 Pre-Run Timer – The pre-run timer setpoint function is used with multi-step starter applications—such as reactor or autotransformer type starters—to define the time that the intermediate or reduced-voltage contactor will be energized. This function is initiated during the start cycle immediately after the pre-start timer function has timed out. (See Figure 6.3 and 5.6.) After the pre-run timer function has timed out, the run (full-voltage) sequence begins. This function is also used in conjunction with the jam function. It disables the jam function until after the motor has accelerated up to full speed.

A setpoint may be entered for the time duration. The function is displayed as PRE-RUN TIMER. During a pre-run condition in the run mode, the message START SEQUENCE is displayed.

The available range is:

- Time: 0 to 60 seconds (in 1 sec. increments)

6.16 Pre-stop Timer – The pre-stop timer setpoint function, initiated after the stop command is received, can be

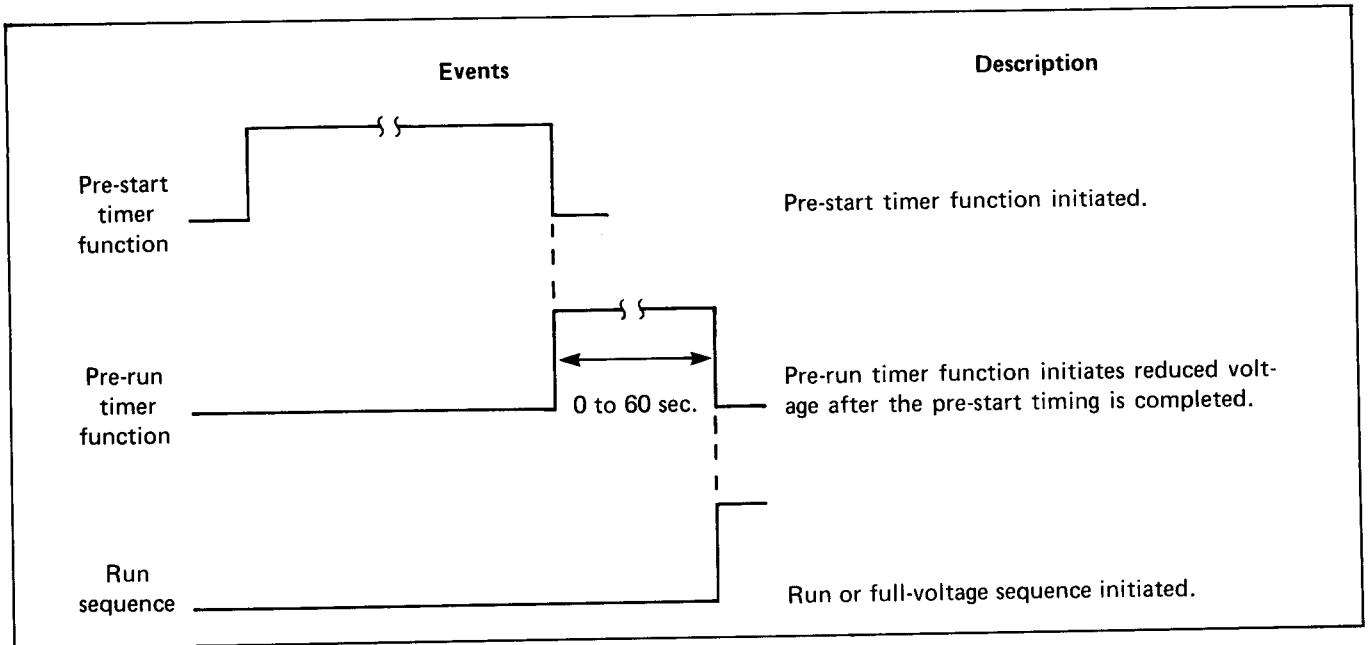

Figure 6.3 – Pre-run Events Diagram

used to control auxiliary functions during the stop sequence. For example, cooling pumps may be enabled or valves and louvers may be closed just **before** the motor turns off. As shown in Figure 6.4, the pre-stop timer function and the Pre-stop Relay are enabled when a stop command occurs.

When the PRE-STOP REPORT-BACK terminal (TB-A7) is energized, the stop sequence is initiated.

In terms of hardware, contacts of the Pre-stop Relay control the auxiliary functions. These contacts are enabled for

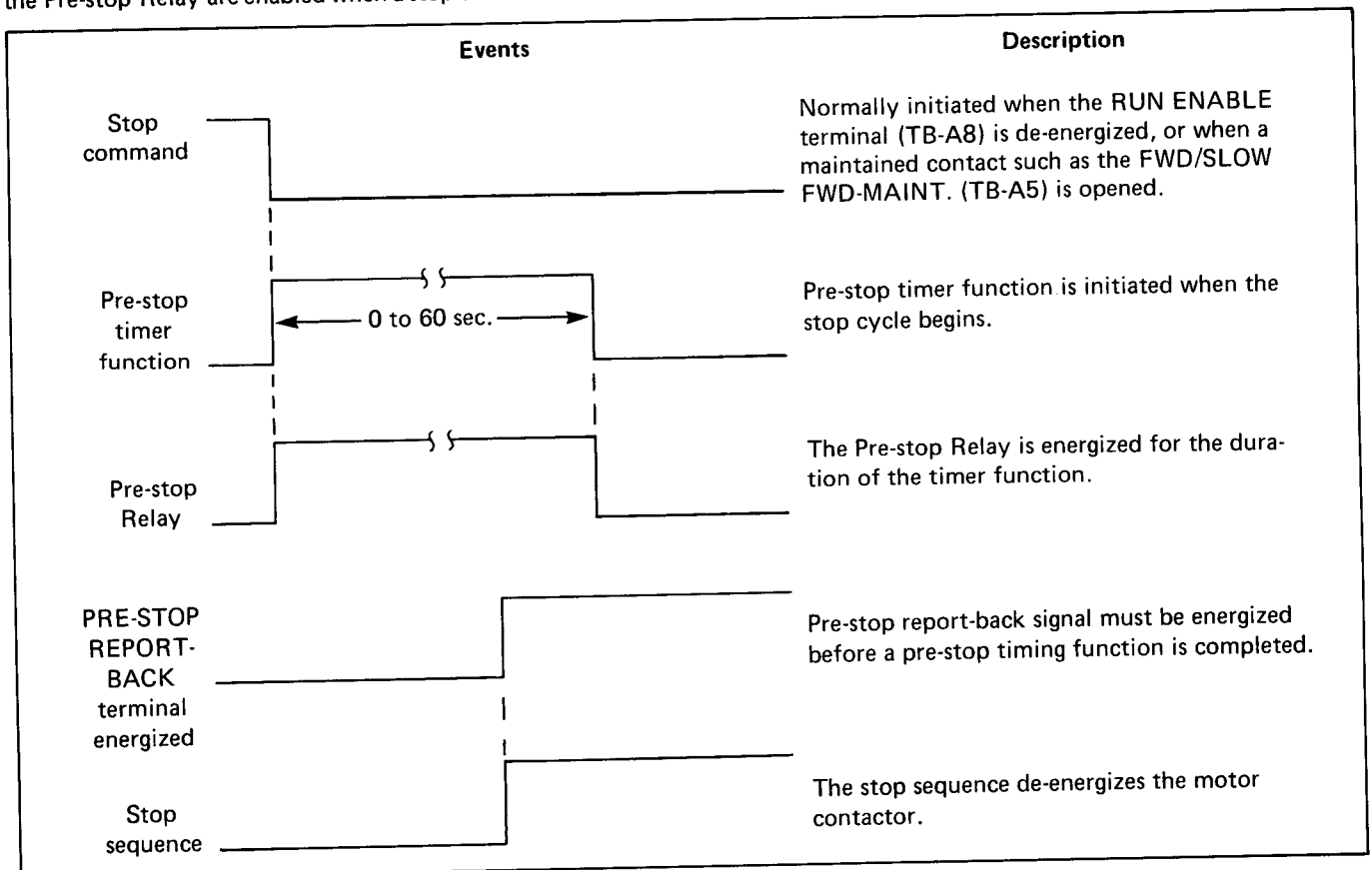

Figure 6.4 – Pre-stop Events Diagram

the programmed time while the pre-stop timer function is in progress.

A setpoint value may be entered for the time duration. The function is displayed as PRE-STOP TIMER.

The available range is:

- Time: 0 to 60 seconds
(in 1 sec. increments)

The operation of this function is influenced by the use of the PRE-STOP REPORT-BACK terminal (TB-A7). In some applications external field devices are connected to this terminal. In such cases, **after** the function is initiated, the pre-stop report-back signal must be received at terminal TB-A7. (See Figure 3.6.) In instances where the signal is not received, and the stop timing cycle is completed, the message BAD STOP RESET is displayed. Automatic restarting is inhibited. A manual reset must be performed after the cause of the problem is cleared. (Use the Operator Panel's RESET pushbutton.)

In applications where the pre-stop report-back capability is not used, a jumper must be placed between terminal TB-16 and the 120 VAC available at terminal TB-15.

If it is desired to disable the pre-stop function, program a zero for the time value.

6.17 Incomplete Sequence – The incomplete sequence setpoint function is applied during a start cycle. It initiates a stop cycle if, at the end of the programmed time, the report-back signal is not received at the INCOMPL SEQ REPORT-BACK terminal TB-A13. (See Figure 6.5.) Typical applications for this function include monitoring

for critical associated conditions such as field loss for synchronous machines or "tie-ins" with additional motors.

A setpoint value may be entered for the time value. The function is displayed as INCOMPL SEQUENCE.

The available range is:

- Time: 0 to 240 seconds
(in 1 sec. increments)

If it is desired to disable the incomplete sequence function, a jumper must be placed between the INCOMPL SEQ REPORT-BACK terminal (TB-22) and the 120 VAC at TB-21. (See Figure 3.6.)

6.18 Anti-backspin – The anti-backspin setpoint function prevents a motor restart for the duration of the programmed time. The anti-backspin setpoint time is initiated immediately after the motor's stop cycle is complete. This prevents attempting to start the motor while it is rotating in a reverse direction, as may be caused by certain types of loads. (See Figure 5.7.) A typical example is the backspin of a pump and motor caused by the descent of a column of water after pumping is terminated.

A setpoint may be entered for the time value. The function is displayed as ANTI-BACKSPIN.

The available value is:

- Time: 0 to 240 seconds
(in 1 sec. increments)

If it is desired to disable the anti-backspin function, enter zero for the time value.

6.19 Anti-recycle, Min – The anti-recycle setpoint function prevents a motor restart for the duration of the

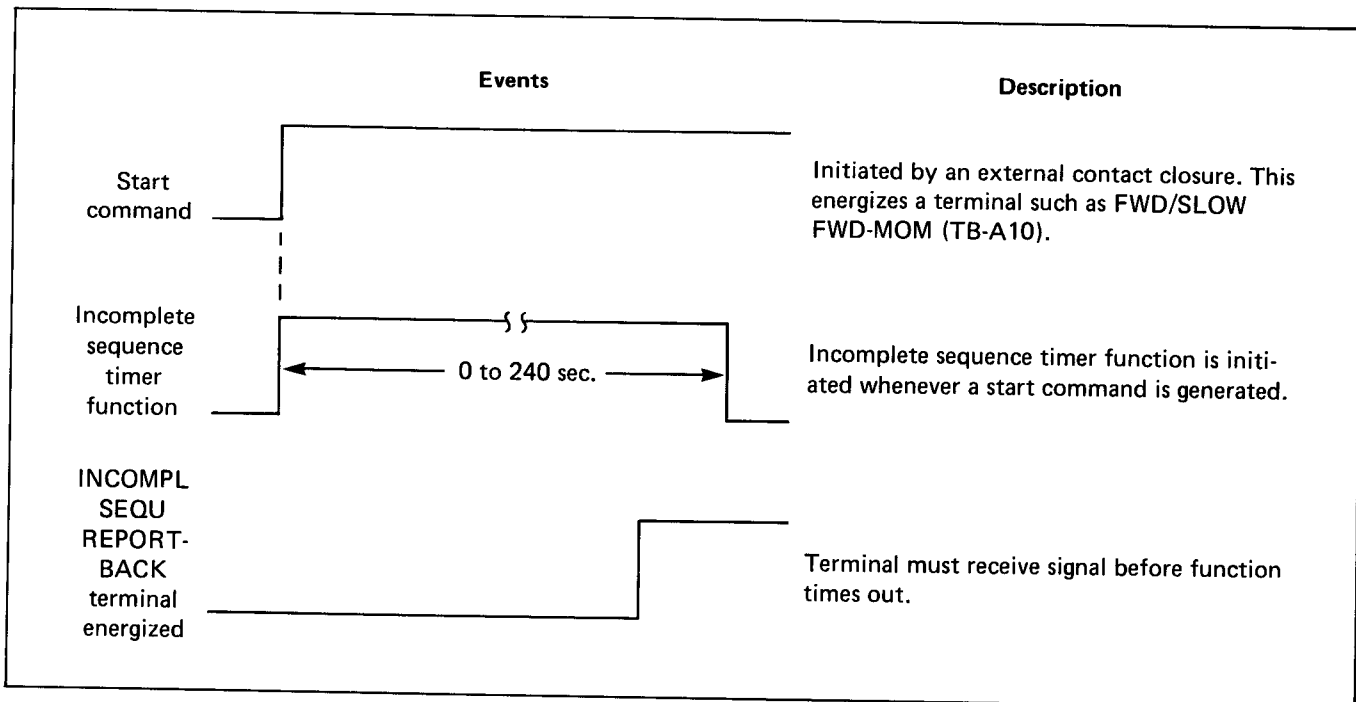

Figure 6.5 – Incomplete Sequence Events Diagram

programmed time. The function begins timing when the motor's start cycle is complete. The function is used to prevent:

- Jogging or other rapid restarts that could inadvertently occur
- Restarting of the motor whether or not the start cycle was completed

A setpoint may be entered for time duration. The function is displayed as ANTI-RECYCLE, MIN.

The available range is:

- Time: 0 to 60 minutes
(in 1 min. increments)

Note: this is the only IQ-2000 setpoint timing function which is in minute increments.

If it is desired to disable the anti-recycle function, enter zero for the time value.

6.20 Time Undervoltage – The time undervoltage function provides the capability to initiate a start cycle after the incoming AC supply is interrupted—that is, drops below 70% of the normal voltage. If the incoming AC supply is restored before the time undervoltage setpoint time has elapsed, a start cycle is initiated. This is utilized with a 3-wire momentary contact START/STOP pushbutton application. It is **not** necessary with a maintained-contact start control application. (See Figure 6.6.)

The AC line undervoltage time setpoint must be programmed longer than the time undervoltage setpoint as described in Paragraph 6.13.

A setpoint may be entered for time duration. The function is displayed as TIME UNDER VOLT.

The available range is:

- Time: 0 to 20 seconds
(in 1 sec. increments)

If it is desired to disable the timer undervoltage function, enter a zero for the time value.

6.21 Post-start Timer – The post-start timing setpoint function, initiated after the end of the start sequence, can be used to enable auxiliary control functions **after** the sequence begins. (See Figure 6.7.) For example, a load may be increased on a motor; another motor may be enabled; or, in stepping or process control applications, the next step in the process may be enabled.

In terms of hardware, the Post-start Relay is energized to control the auxiliary functions. These contacts are energized after the post-start timer function is complete.

A setpoint may be entered for the time value. The function is displayed as POST-START TIMER.

The available value range is:

- Time: 0 to 60 seconds
(in 1 sec. increments)

If it is desired to disable the post-start timer function, program a zero for the time value.

6.22 Post-stop Timer – The post-stop timer setpoint function, initiated immediately after the stop sequence is complete, can be used to disable auxiliary functions **after** the sequence. (See Figure 6.8.) For example, cooling pumps and other motors may be controlled. In process control, the next step in the process may be disabled.

In terms of hardware, the Post-stop Relay is energized to control the auxiliary functions.

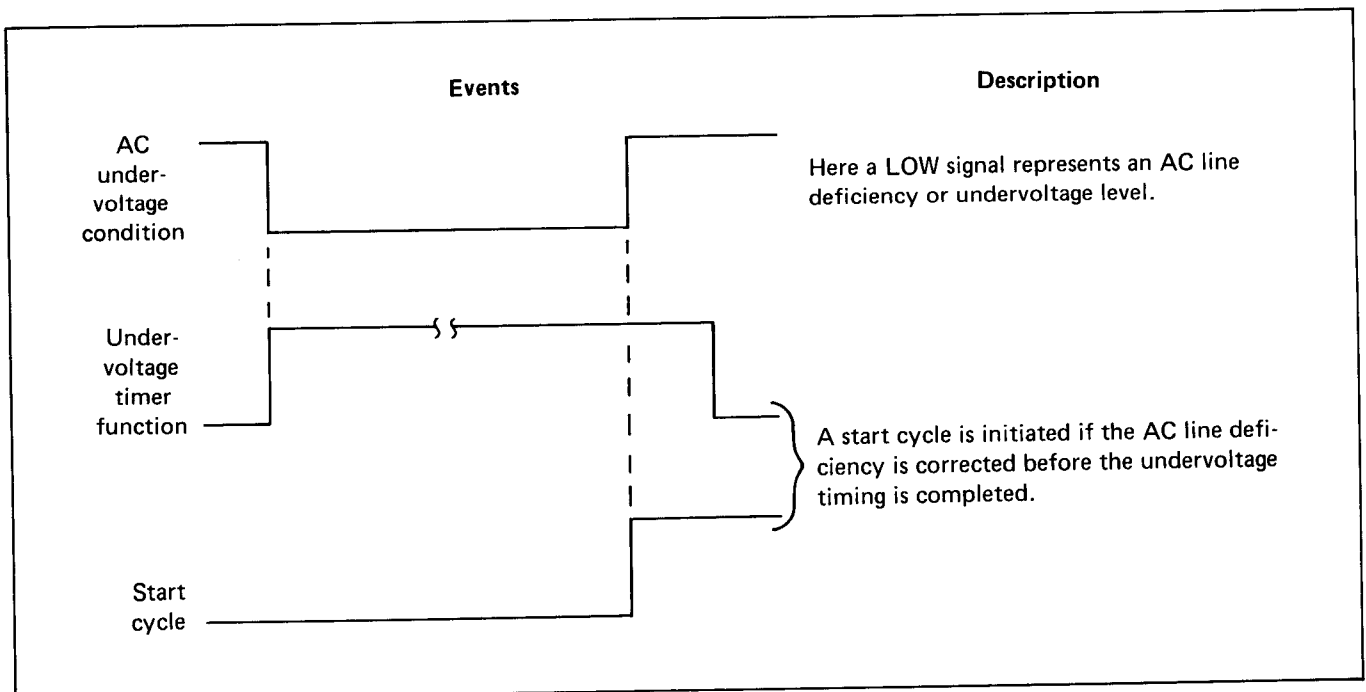

Figure 6.6 – Time Undervoltage Events Diagram

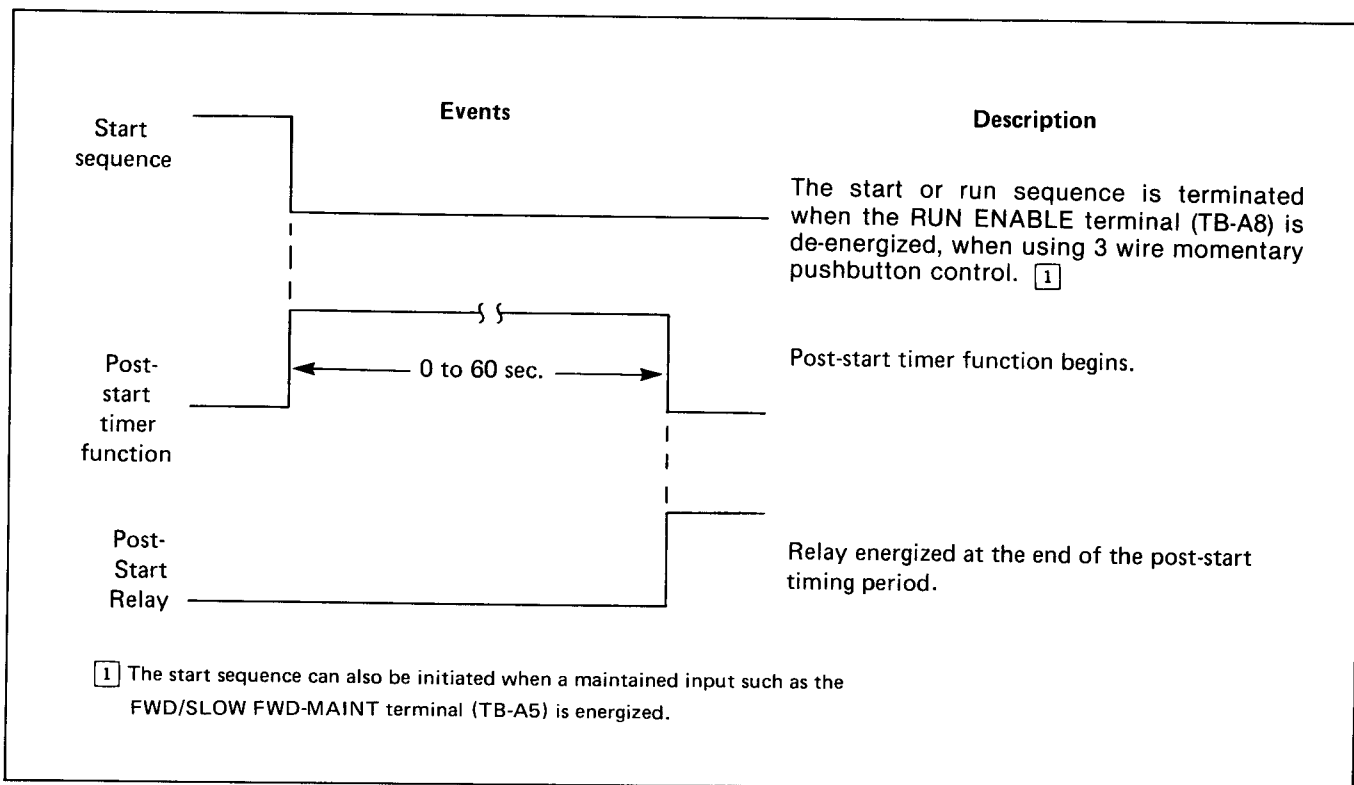

Figure 6.7 — Post-start Events Diagram

A setpoint may be entered for the time value. The function is displayed as POST-STOP TIMER.

The available value range is:

- Time: 0 to 60 seconds
(in 1 sec. increments)

If it is desired to disable the post-stop timer function, program a zero for the time value. (This action also disables the Post-stop Relay.)

6.23 Start Counts/Hours — The start counts/hours setpoint function limits the number of motor starts over a programmed period of time. If the number of starts within a period exceeds the setpoint, a new start cycle is inhibited until the programmed period has elapsed. Note that the function is programmed in hours, but displayed in minutes. When, the limit is exceeded, the Operator Panel will display TOO MANY STARTS WAIT X MIN. Here, X is the number of minutes before a start cycle can be initiated. After the elapsed time a new start command can reinstate a start cycle.

Setpoint values may be entered for counts and time. (The counts are entered in the TRIP window.) The function is displayed as START COUNTS/HRS.

The ranges of values are:

- Counts: 1 to 10
(in 1 count increments)
- Hours: 0 to 24
(in 1 hour increments)

If it is desired to disable the start counts/hours function, program a zero for the time value.

6.24 Open/Unbalance Phase — The open/unbalance phase setpoint function monitors for possible current phase unbalance of the actual motor currents. If this factor exceeds the setpoint values for the programmed time, the red ALARM LED on the Operator Panel flashes and a warning message is displayed.

(This function, however, does not cause a trip condition since the phase unbalance is already incorporated into the motor rotor protection algorithm. Should the calculated temperature become too high due to a combination of current and phase unbalance, the trip condition results.)

Setpoint values may be entered for the unbalance and time values. (The unbalance value is entered in the ALARM window.) The function is displayed as OPEN UNBALANCE PHASE.

The available ranges are:

- Unbalance phase: 5 to 30% of full-load motor current
(in 1% increments)
- Time: 0 to 25 seconds
(in 1 sec. increments)

6.25 Full-load Current — The full-load current setpoint function monitors for the maximum continuous RMS current that can be permitted in the motor stator. (This value is the motor manufacturer's recommended full-load ampere rating.)

Primarily this function is used internally by the IQ-2000. There are no external reactions as the direct result of reaching the setpoint level. In the monitoring mode, actual current values are displayed in the VALUES windows; A, B and C each represents a single phase.

CAUTION

Many of the IQ-2000's protection functions, including the motor temperature protection algorithm, use the full-load current setpoint value to calculate the trip points. If this value is incorrect, motor damage can result.

A setpoint may be entered for the ampere value. (It is entered in the TIME window.) The display appears as FULL LOAD CUR-A.

The available range is:

- Amps: 1 to 1000
(in 1 amp increments)

6.26 Current Transformer Ratio – The current transformer (C.T.) ratio setpoint function defines the turns ratio of the C.T.

The turns ratio is entered in the TIME window, although only the first factor of the ratio is used. Thus the entry of 60 represents 60:1. The value is used internally by the IQ-2000, and thus there is no external reaction.

Available C.T. turns ratio setpoint values are:

2:1	20:1	80:1
5:1	30:1	100:1
8:1	40:1	120:1
10:1	50:1	160:1
15:1	60:1	200:1

The turns ratio for the C.T. is listed on each application's Ampgard Schematic or outline. (See Paragraph 3.1.) A

current transformer with a 5-ampere secondary is always used with the IQ-2000. Thus a 300:5 turns ratio requires a setpoint value of 60:

$$\frac{300}{5} = 60$$

CAUTION

Be careful when determining the C.T. turns ratio. An improper value can cause the IQ-2000 to receive incorrect motor current data. Motor damage could result.

6.27 Potential Transformer Ratio – The potential transformer (P.T.) ratio setpoint function defines the turns ratio of the optional P.T.

The turns ratio is entered in the TIME window, although only the first factor of the ratio is used. Thus the entry of 35 represents 35:1. This value is used internally by the IQ-2000, and thus there is no external reaction.

Available P.T. turns ratio setpoint values are:

0:1	35:1
2:1	40:1
4:1	55:1
5:1	60:1
20:1	70:1
30:1	

The turns ratio of the P.T. is chosen so that the resulting secondary voltage equals 120 VAC. Thus a line voltage of 4200 requires a 35:1 ratio:

$$\frac{4200}{120} = 35$$

If a potential transformer (P.T.) is not used, program a zero in the TIME window.

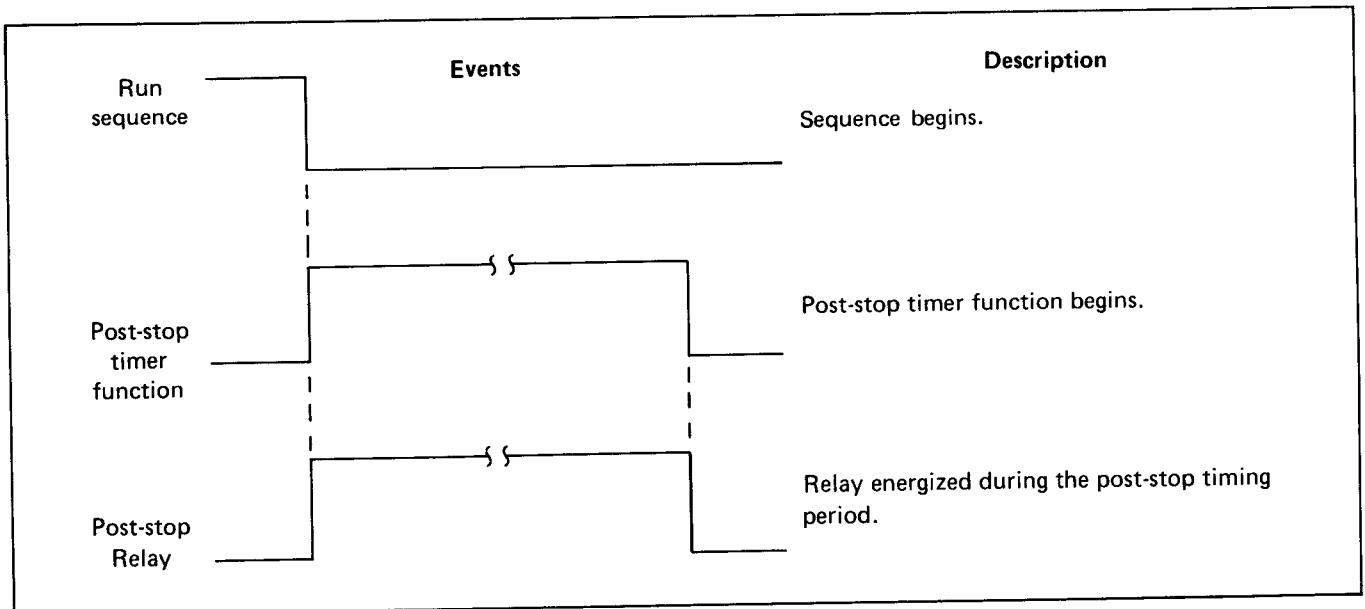
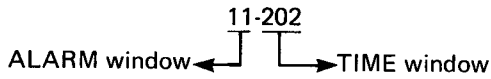

Figure 6.8 – Post-stop Events Diagram

6.28 Starter Class – The starter class setpoint function determines the actual cycling of the motor contactor(s). A total of 16 different starter classes, as listed in Table 6.C, may be chosen. Each class requires that 2 values be entered in different windows. The values are simply the class designation. For example:



Keep in mind that the IQ-2000 enables the motor contactor(s) by means of interposing relays. It makes use of some or all of relays C1 thru C4. Contacts from each of these relays are wired to the coil of an interposing relay. (See Figure 6.9.) These, in turn, are wired to the main contactor(s). Selecting the starter type determines the operations of the contactor(s). Table 6.D shows the relationship between each of the possible starter classes and relays C1 thru C4.

**Table 6.C
STARTER CLASSES**

Starter Class	Description
11-202	Across-the-line, non-reversing
11-212	Across-the-line, reversing
11-502	Primary reactor, reduced-voltage, non-reversing
11-512	Primary reactor, reduced-voltage, reversing
11-602	Auto-transformer, reduced-voltage, non-reversing
11-612	Auto-transformer, reduced-voltage, reversing
11-902	Multi-speed, non-reversing
11-912	Multi-speed, reversing ¹
13-202	Wound-rotor, non-reversing
13-212	Wound-rotor, reversing
14-202	Synchronous, full-voltage, non-reversing
14-212	Synchronous, full-voltage, reversing
14-502	Synchronous, primary reactor, reduced-voltage, non-reversing
14-512	Synchronous, primary reactor, reduced-voltage, reversing
14-602	Synchronous, auto-transformer, reduced-voltage, non-reversing
14-612	Synchronous, auto-transformer, reduced-voltage, reversing

¹ This starter has 2 forward speeds and 1 reverse.

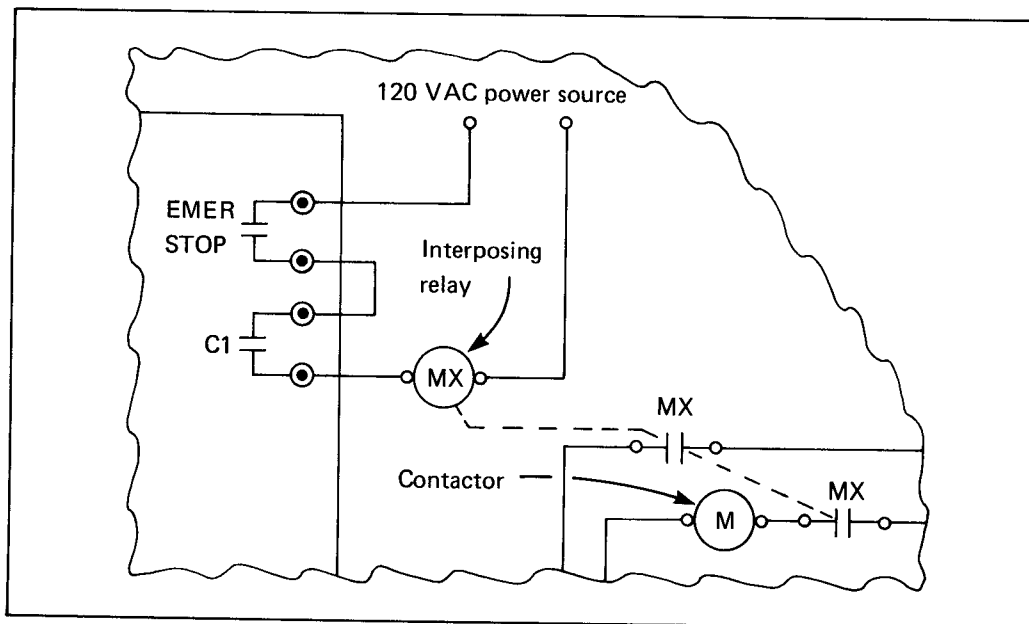

Figure 6.9 – Interposing Relay Wiring (typical)

Table 6.D
RELAY C1 THRU C4 FUNCTIONS

Starter Class	C1	C2	C3 ¹	C4 ²
11-202	FWD	-	-	-
11-212	FWD	RVS	-	-
11-502	FWD	-	FWD MOM	-
11-512	FWD	RVS	FWD/RVS MOM	-
11-602	FWD	-	FWD MOM	FULL VOLTAGE
11-612	FWD	RVS	FWD/RVS MOM	FULL VOLTAGE
11-902	FWD SLOW	-	FWD FAST	FWD FAST
11-912	FWD SLOW	RVS SLOW	FWD FAST	FWD FAST ³
13-202	FWD	-	-	-
13-212	FWD	RVS	-	-
14-202	FWD	-	-	-
14-212	FWD	RVS	-	-
14-502	FWD	-	FWD MOM	-
14-512	FWD	RVS	FWD/RVS MOM	-
14-602	FWD	-	FWD MOM	FULL VOLTAGE
14-612	FWD	RVS	FWD/RVS MOM	FULL VOLTAGE

¹ The closure time of the Forward Momentary (C3) relay is determined by the pre-run timer setpoint function. See Paragraph 6.15.

² The Post-start Relay, when used, is energized immediately after the pre-run timer function times out.

³ The Class 11-912 starter has only 1 reverse speed.

Section 7

MONITORING AND TROUBLESHOOTING

7.0 General – This Chapter is designed to assist maintenance personnel to carry out monitoring operations and troubleshooting procedures. It is divided into 2 general areas of information:

- Operator Panel monitoring procedures (Par. 7.1)
- Isolating a malfunction (Par. 7.2)

— DANGER —

All maintenance procedures **must** be performed only by qualified personnel who are familiar with the IQ-2000 and its associated controlled motor and machines. Failure to observe this caution can result in serious or even fatal personal injury and/or equipment damage.

— DANGER —

The following procedures at times involve working in equipment areas where the hazard of fatal electrical shock is present. Live parts are exposed. Personnel must exercise extreme caution to avoid injury, including possible fatal injury.

7.1 Panel Operations – The following functions are carried on by means of the Operator Panel:

- Normal operational reporting (Par. 7.1.1)
- Programming setpoint values (See Par. 4.3)
- Reviewing setpoint values (Par. 7.1.2)
- Monitoring electrical characteristics (Par. 7.1.3)

7.1.1 Normal Operational Reporting – The FUNCTION window of the Operator Panel provides a reporting function that occurs during the normal operation of the IQ-2000. Commands such as START SEQUENCE and POST STOP are used to report the various sequences involved with starting, running and stopping the motor. Figure 7.1 shows the relationship among the displays and the various operations of the IQ-2000.

7.1.2 Reviewing Setpoints – The setpoint value reviewing operation allows maintenance personnel to observe programmed values while the IQ-2000 is in the run mode. This function gives maintenance personnel the ability to examine or determine setpoints without entering a cycle stop

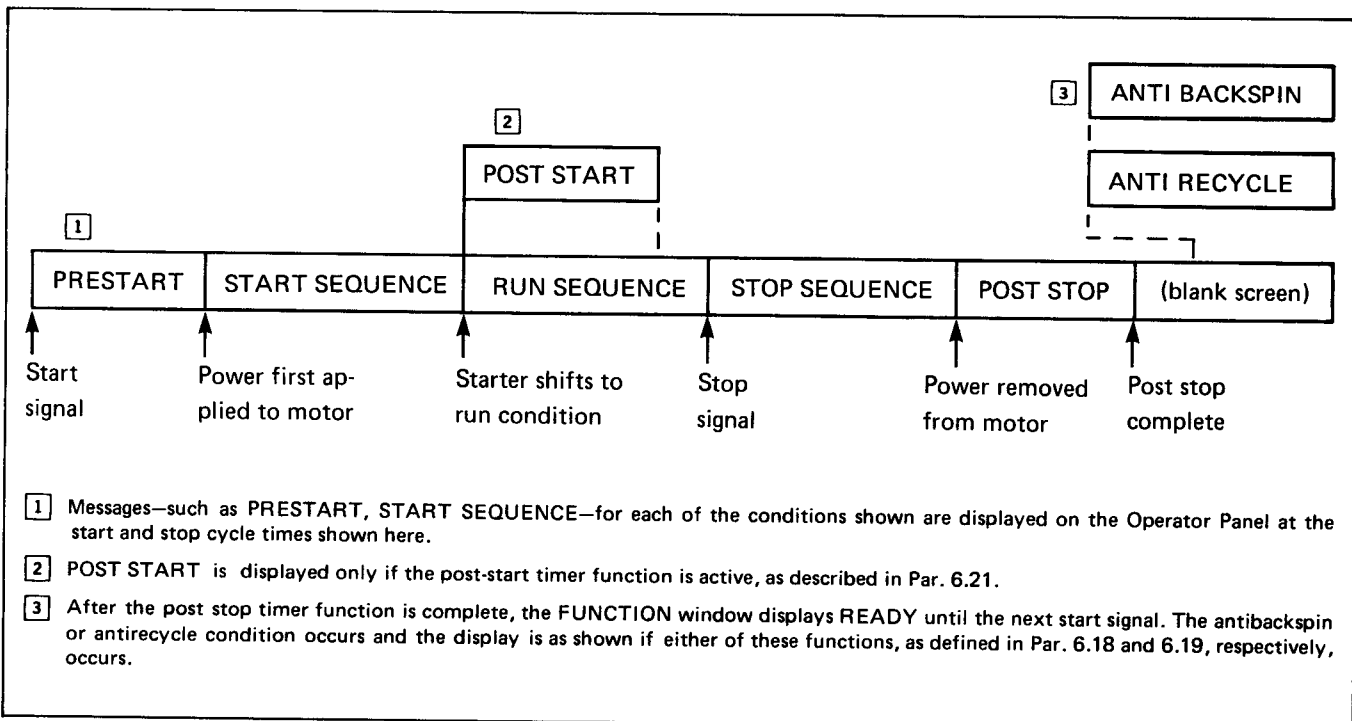

Figure 7.1 – Display/Run Sequence Relations

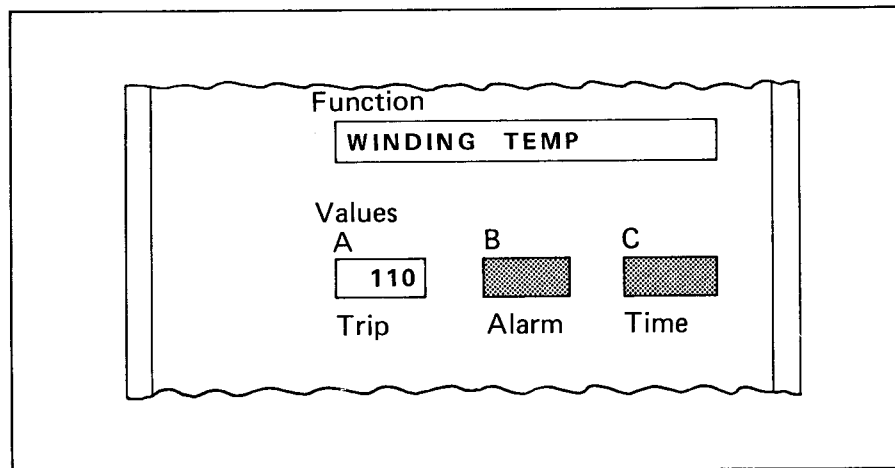

Figure 7.2 – Reviewing Message

condition that shuts down motor operation. The following steps assume the keyswitch is in the RUN position.

Step 1 – Depress the SET POINTS pushbutton. At this time WINDING TEMP is displayed in the FUNCTION window. (See Figure 7.2.) Also, all values related to this function are displayed.

Step 2 – Depress the STEP pushbutton. The next setpoint function along with its value(s) will be displayed. (Functions appear in the same order as those listed in Table 6.B.)

Step 3 – Depress the STEP pushbutton repeatedly to sequence through the functions. (Note: if the STEP pushbutton is not depressed every 4 seconds, the reviewing operation automatically terminates. The display then returns to the message shown just before the reviewing of setpoints was begun.)

Note: setpoints can be reviewed “automatically;” each setpoint is sequentially displayed for 4 seconds, in the run mode. To initiate this automatic setpoint review:

- Depress the SET POINTS pushbutton
- Depress the CYCLE/SELECT pushbutton

When all the setpoints have been displayed once, the automatic sequencing will end.

7.1.3 Monitoring Characteristics – the electrical characteristics monitoring operation allows maintenance personnel/operators to observe selected parameters associated with the motor and motor starter. A listing and complete description of these electrical characteristics is given in Table 7.A.

This type of monitoring operation can be performed in one of 2 ways:

- **Manual Stepping.** Individual displays of electrical characteristics can be manually called up and/or advanced according to the operator’s needs. To initiate the characteristics display and to continue stepping through the list, depress the STEP pushbutton. (This assumes the run mode.)

- **Automatic Stepping.** All electrical characteristics can be displayed on a sequential basis. Each function is displayed for approximately 4 seconds. Once all functions have been shown, the automatic monitoring operation is terminated.

To initiate this operation, depress the CYCLE/SELECT pushbutton. (This assumes the run mode.)

7.2 Malfunction Isolation – In the event that a malfunction occurs, certain troubleshooting procedures can be used to assist in localizing its cause. This troubleshooting approach is divided into 2 broad situations:

- Operator Panel is inoperative (Par. 7.2.1)
- Monitoring operations can be performed (Par. 7.2.2)

7.2.1 Panel Inoperative – If the Operator Panel is inoperative, either the LEDs and displays are off, or they are not responding properly. In this case use the procedures listed in Table 7.B. When using the list, keep in mind that:

- The most probable problems or the simplest to verify are listed first. For this reason, always follow the order of the Table’s suggestions.
- If the Processor Module requires replacement, refer to Chapter 8 for recommended procedures.

— DANGER —

If a Processor Module is replaced, it is necessary to reprogram all setpoint values that apply to the specific IQ-2000 application. **Do not** attempt to restart the motor until all values are entered and validated. (Use the application’s Setpoint Record Sheet and Paragraph 4.3.) Damage to equipment and/or personnel may occur if this procedure is not followed.

7.2.2 Panel Operating – If, during a malfunction, the Operator Panel continues to operate, it can provide valuable information. Information obtained from it can be divided into 2 groups:

Table 7.A
MONITORING OPERATION

Function [1]	Description
LINE VOLTAGE [2]	All 3 phases are displayed in the A, B and C windows of the Operator Panel.
MOTOR CURRENT-A	All 3 phases are simultaneously displayed in the A, B and C windows of the Operator Panel.
MOTOR CURRENT-%	The percents of the full-load current of all 3 phases are displayed in the A, B and C windows of the Operator Panel.
GROUND CURRENT-A	The actual ground leakage current of a grounded wye system is displayed in amperes in the A window of the Operator Panel.
WINDING TEMP-C [3]	The highest reading from the 6 possible motor RTDs is displayed in the A window of the Operator Panel.
MOTOR BRG TEMP-C [3]	The readings from the 2 motor bearing RTDs is displayed in the A and B windows of the Operator Panel.
LOAD BRG TEMP-C [3]	The readings from the 2 load RTDs is displayed in the A and B windows of the Operator Panel.
KILOWATTS [2]	The actual kilowatts of power being used is displayed in the A window of the Operator Panel.
KILOVARS [2]	The instantaneous kilovars is displayed in the A window of the Operator Panel.
POWER FACTOR-% [2]	The actual power factor, ranging from 0 to $\pm 100\%$ is displayed in the A window of the Operator Panel.
FREQUENCY-HZ	The frequency of the incoming AC line is displayed to the closest whole number of Hertz/second.
MEGAWATT HOURS [2] [4]	The actual megawatt hours total accumulated to date. This data is retrieved from a non-volatile memory storage area and displayed in the A window of the Operator Panel.
RUN TIME [4]	The actual run time of the IQ-2000 to date. This data is retrieved from a non-volatile memory storage area and displayed in the A window of the Operator Panel.
OPERATIONS-COUNT [4]	The total start cycles to date regardless of AC power interruptions. This data is retrieved from a non-volatile memory storage and displayed in the A window of the Operator Panel.
<p>[1] As displayed in the FUNCTION window of the Operator Panel.</p> <p>[2] If the optional potential transformer (P.T.) is not present, zeroes will be displayed in the value windows.</p> <p>[3] If the optional RTD Module is not present, zeroes are displayed in the value windows.</p> <p>[4] These values are updated in non-volatile memory once each 24 hours. Note: the IQ-2000 must be continuously (AC power applied) for a full 24 hours before the new information is stored.</p>	

- Alarm conditions (Par. 7.2.2.1)
- Trip conditions (Par. 7.2.2.2)

7.2.2.1 Alarm Conditions – An alarm condition occurs when one of the electrical characteristics exceeds the programmed setpoint value. Note, however, that some alarm characteristics must exceed the setpoint value for a programmed time value **before** the alarm condition occurs.

When this condition happens, the red ALARM LED lights. Also, a message is displayed in the FUNCTION window to assist with the isolation process. If the application has external devices connected with the IQ-2000's internal Alarm Relay, those devices could give additional warning.

Alarm conditions all have the following in common:

- The internal Alarm Relay is energized when the condition occurs.
- The form C relay contacts, available at the interface (TB-B10 thru B12), are brought out from the Alarm Relay.
- The condition is automatically cleared if the characteristic causing the condition falls below the setpoint.

All possible alarm conditions are listed in Table 7.C. Related probable cause and solutions are also shown.

Table 7.B

TROUBLESHOOTING: OPERATOR PANEL INOPERATIVE

Possible Malfunction	Item to be Verified
Incoming AC deficient	Verify that 120 VAC ($\pm 15\%$) exists between terminals TB-D2 and TB-D3. (Refer to the Ampgard Schematic to further isolate a deficient AC line.)
Blown fuse	Check the fuses located on the Processor Module. (See Figure 7.3.)
Processor Module malfunction	Verify that all connections to the terminal blocks are secure and that the connectors are installed properly. If all connections and connectors are OK, replace the Processor Module as directed in Chapter 8.

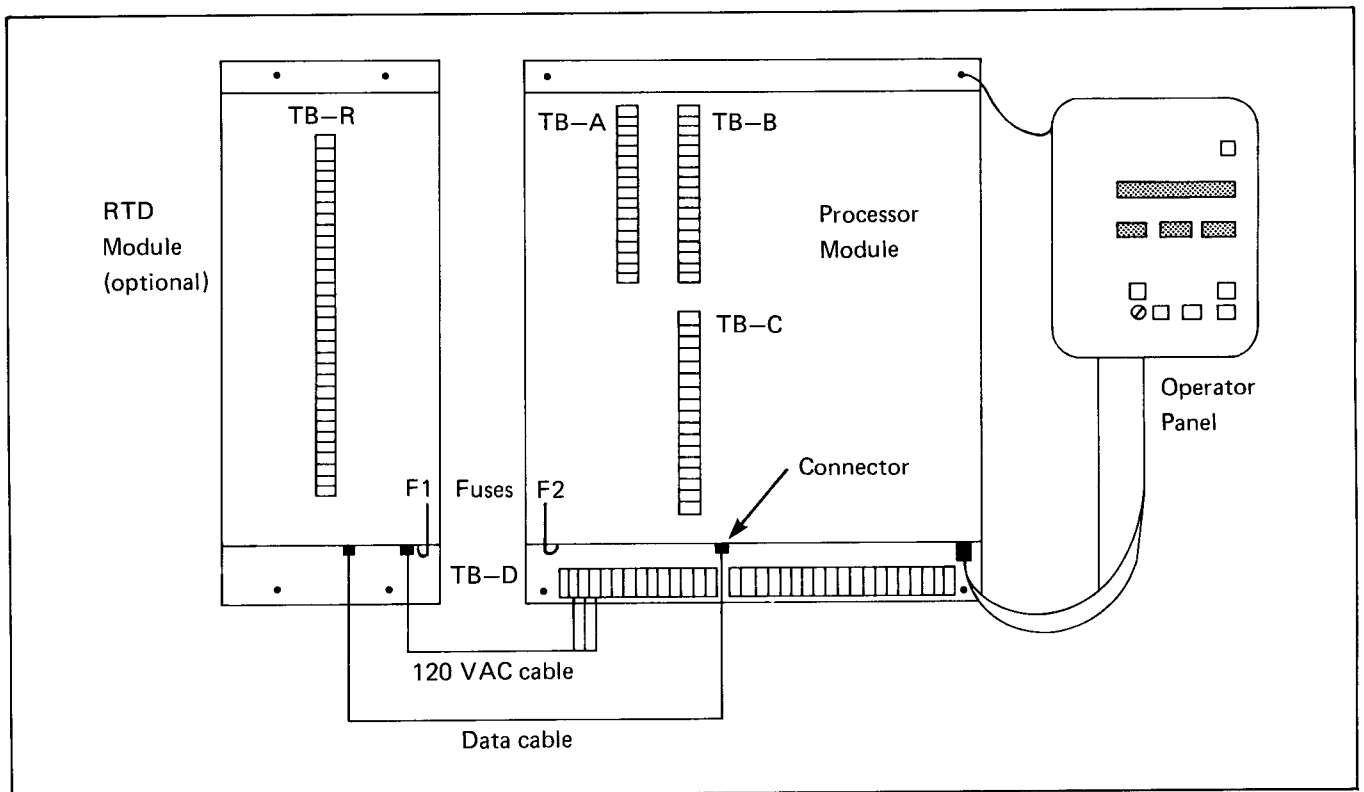

Figure 7.3 – Processor and RTD Module

7.2.2.2 Trip Conditions – A trip condition is a situation that causes the main contactor to open and motor to stop. These conditions fall into 2 groups:

- When the IQ-2000 detects a malfunction. These are conditions which may be internal to the control—such as an opto-coupler failure. They may also be external to the control—such as a broken report-back signal wire from the machine or process.
- When the selected electrical characteristics exceed the programmed setpoint values, including, at times, a time setpoint.

When a trip condition occurs, the red TRIP LED lights and a message is displayed in the FUNCTION window to assist the operator.

Trip conditions have these characteristics in common:

- A “picture” of the metering functions at the time the trip occurred is stored in memory and can be recalled

by depressing the STEP pushbutton. The order of the electrical characteristics displayed will be identical to the listing in Table 7.A.

Note: depressing the RESET pushbutton clears the electrical characteristics stored when the trip condition occurred. If after depressing the RESET pushbutton, the OVERLOAD WARNING message appears, wait until the motor cools before restarting.

- The internal Trip Relay is actuated when the condition occurs.
- The form C relay contacts, available at the interface (TB-B13 thru 15), are brought out from the Trip Relay.
- The condition must be manually reset. (Use the RESET pushbutton.)

All possible trip conditions are listed in Table 7.D. Related probable causes and solutions are also shown.

Table 7.C
ALARM CONDITIONS

FUNCTION Window Display	Probable Cause	Solution
OVERLOAD WARNING	The rotor temperature monitoring exceeded 75% of the maximum allowable value ¹	Monitor electrical characteristics to further isolate the malfunction to an area such as the incoming AC line, or motor/load. Note: If a trip or restart condition occurs and the OVERLOAD WARNING message is still displayed after the RESET pushbutton is depressed, wait until the motor cools before restarting.
WINDING TEMP MOTOR BGR TEMP LOAD BGR TEMP GROUND FAULT OPEN/UNBALANCE PHASE	In each case the actual electrical value monitored has exceeded the alarm setpoint value for the function displayed. In addition, the SET POINT LED illuminates to indicate that the numbers displayed in the VALUE windows are the programmed setpoints.	In each of the 5 different displays perform a monitoring function to further isolate the malfunction. Note: If the actual temperature of one or more of the RTDs does not correspond to the reading (in degrees Centigrade), suspect the RTDs, RTD wiring or the RTD Module.
¹ The Alarm Relay is not tripped when an overload warning condition occurs.		

Table 7.D
TRIP CONDITIONS

FUNCTION Window Display	Probable Cause	Solution
LOCKED ROTOR CURRENT-A	<p>The rotor winding temperature storage, as directed by the rotor algorithm, has exceeded the maximum allowable value.</p> <p>The actual locked-rotor current setpoints are displayed in the VALUES windows of the Operator Panel.</p>	Monitor the electrical characteristics associated with the motor current to further isolate a malfunction to areas such as the AC line or motor/load.
WINDING TEMP MOTOR BGR TEMP LOAD BGR TEMP GROUND FAULT INST OVERCURRENT JAM UNDERLOAD START ULTIMATE TRIP OVERVOLTAGE UNDERVOLTAGE	In each case the actual electrical value monitored has exceeded the trip setpoint value for the function displayed. In addition, the SET POINT LED illuminates to indicate that the numbers displayed in the VALUES windows are the programmed setpoints.	<p>Monitor the associated electrical characteristics (as listed in Table 7.A) to further isolate the malfunction.</p> <p>Note: If the actual temperature of one or more of the RTDs does not correspond to the reading (in degrees Centigrade), suspect the RTDs, RTD wiring, or the RTD Module.</p>
OPT COUPLER BAD	A malfunction internal to the Processor Module.	Replace the Processor Module. (See Chapter 8.)
INC SEQ RESET	The INCOMPL SEQ REPORT-BACK terminal (TB-A13) was not energized at the appropriate time during the start cycle.	Monitor terminal TB-A13 during an actual start cycle.
BAD REPORT BACK	The report-back contacts from the main contactor relay did not open or close in response to the commands to the Processor Module Relay(s) C1, C2, C3 and C4.	<p>Verify that the control wires associated with the interposing relay and power contactor are properly connected.</p> <p>Refer to the Ampgard Schematic, or equivalent, and examine the main contactor's (or contactors') interlock contacts functioning as follows:</p> <ul style="list-style-type: none"> ● C1 Report Back—TB-D17 ● C2 Report Back—TB-D18 ● C3 Report Back—TB-D19 1 ● C4 Report Back—TB-D20 ● Common TB-D15
BAD STOP RESET	The PRE-STOP REPORT-BACK terminal (TB-A7) failed to be energized at the correct time in the stop cycle.	Monitor terminal TB-A7 during an actual stop cycle.
BAD START RESET	The PRE-START REPORT-BACK terminal (TB-A9) failed to be energized at the correct time in the start cycle.	Monitor terminal TB-A9 during an actual start cycle.

(Cont'd.)

Table 7.D
TRIP CONDITIONS (Con't.)

FUNCTION Window Display	Probable Cause	Solution
REMOTE TRIP	The REMOTE TRIP terminal (TB-A14) was energized.	Monitor terminal TB-A14.
PHASE ERROR	The start cycle was prevented because an incoming AC line out-of-phase condition existed or the P.T. ratio setpoint is set other than 0 when no potential transformers are supplied in the application.	Monitor the incoming AC line. Check P.T. ratio setpoint and P.T. wiring.
ILLEGAL INPUT	Two or more simultaneously input contacts gave contradictory commands.	Check EMER STOP (TB-A2), and other start and stop inputs.
TOO MANY STARTS ^[2]	Too many start cycles have been attempted for the programmed setpoint value.	Verify that the start commands have been occurring legally. (See Table 5.C for a description of possible input terminals that can initiate start commands.)
EMERGENCY STOP	LOCK-OUT STOP switch was pushed, thereby energizing the EMER STOP terminal TB-A2. ^[3]	Depress the RESET pushbutton which opens the LOCK-OUT STOP switch, thereby de-energizing TB-A2.
CHECK SUM RESET	A data transfer malfunction internal to the IQ-2000 that occurred when the keyswitch is placed in the RUN position.	Depress the RESET pushbutton and turn the keyswitch from the RUN to the PROGRAM and back to the RUN position.
PHASE UNBALANCE	If the value of the negative sequence current is 50% or more of the positive sequence current, a trip condition is initiated.	Monitor the incoming AC line.
<p>^[1] See Paragraph 6.28 and Table 6.D for a description of the C1, C2, C3 and C4 relays' operation.</p> <p>^[2] The message WAIT XXX MIN will be displayed in the VALUES windows of the Operator Panel at the same time. Here, XXX represents an actual number of minutes.</p> <p>^[3] Not all Ampgard units have this optional switch.</p>		

Section 8

UNIT REPLACEMENT

8.0 General – This Chapter lists a step-by-step approach to be followed when replacing the Processor Module and/or the RTD Module. Before replacement, refer to the information on isolating a malfunction in Chapter 7 to make sure that possible malfunctions external to the Processor and RTD Modules have been eliminated.

Always conform to the following cautions when performing any maintenance functions.

DANGER

The following procedures **must** be performed only by qualified personnel who are familiar with the IQ-2000 and its associated controlled motor and machines. Failure to observe this caution can result in serious or even fatal personal injury and/or equipment damage.

DANGER

If a Processor Module is replaced, it is necessary to re-program all setpoint values that apply to the specific IQ-2000 application. **Do not** attempt to restart the motor until all values are entered and validated. (Use the application's Setpoint Record Sheet and Paragraph 4.3.) Damage to equipment and/or personnel may occur if this procedure is not followed.

8.1 Processor Module Replacement – The following procedure lists the steps needed to replace the Processor Module:

Step 1 – Remove AC power at the main disconnect or the isolation switch of the starter. Verify that all "foreign" power sources to the starter cabinet are disconnected.

Step 2 – Gain access to the Module by pulling the draw-out panel as far forward as it will travel.

Step 3 – Verify that all wires connecting to the terminals of the terminal blocks TB-A, TB-B, TB-C and TB-D are marked and that it is apparent which designations relate to which terminals. (See Figure 8.1.)

Step 4 – Loosen each screw terminal and remove the wires from the terminal blocks.

Step 5 – Unscrew the 2 flat-head screws securing the cable connected between the Processor Module and the Operator Panel. (See Figure 8.2.) Note: alternately turn each screw a few turns CCW to prevent the connector from being skewed and damaging the pins.

Step 6 – Remove the optional Data Cable Connector from the Processor Module. (See Figure 8.1.)

Step 7 – Remove the 4 nuts securing the Processor Module to the mounting panel and carefully remove the Processor Module.

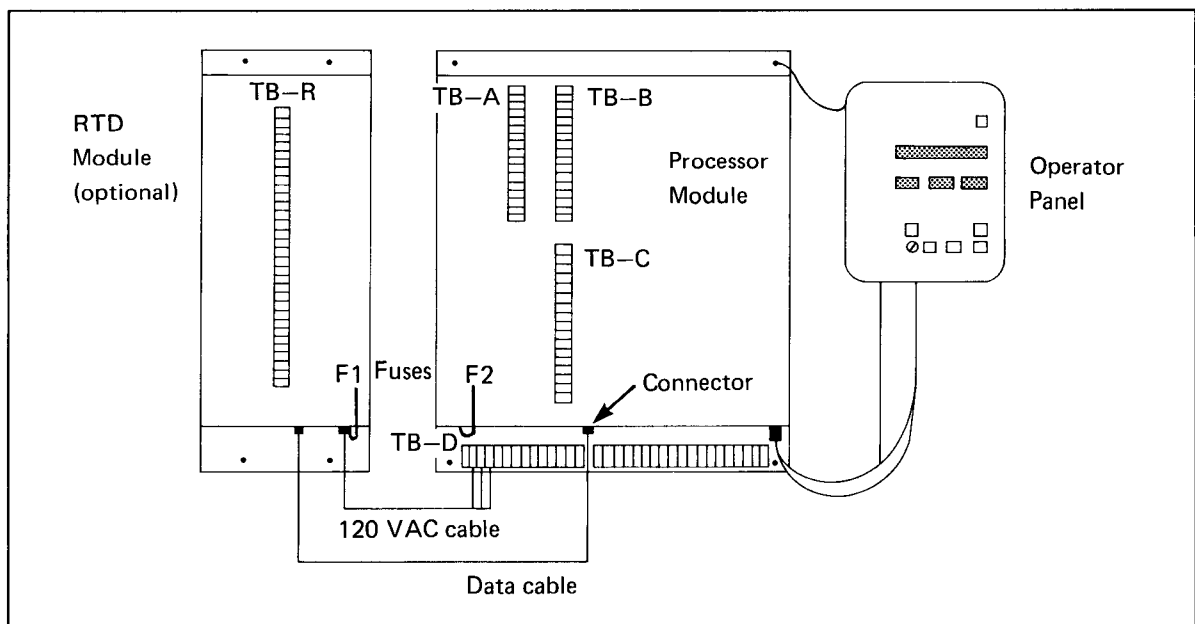

Figure 8.1 – Processor and RTD Module

Step 8 – Reverse the procedure listed in Steps 2 thru 5 to install a replacement Processor Module.

8.2 RTD Module Replacement – The following procedure lists the steps needed to replace the RTD Module:

Step 1 – Remove the AC power at the main disconnect switch.

Step 2 – Gain access to the Module by pulling the draw-out panel as far forward as it will travel.

Step 3 – Verify that all wires connecting to the terminals of terminal block TB-R are clearly marked and it is clear which terminal relates to the designations. (See Figure 8.1.)

Step 4 – Loosen each screw terminal and remove the wires from them.

Step 5 – Remove the AC power connections at the Processor Module terminals TB-D1, TB-D2 and TB-D3.

Step 6 – Unscrew and remove the Data Cable Connector at the Processor Module.

Step 7 – Remove the 4 nuts securing the RTD Module to the mounting panel and carefully remove the Module.

Step 8 – Reverse the procedure listed in Steps 2 thru 7 to install a replacement RTD Module.

8.3 Terminal Identification – Identification for the external terminals of the IQ-2000's TB-A, -B, and -C are shown in Figure 8.3. TB-D, which is attached on the IQ-2000's mounting flange, is also shown. For terminal identification on the RTD Module's TB-R, refer to Figure 3.3.

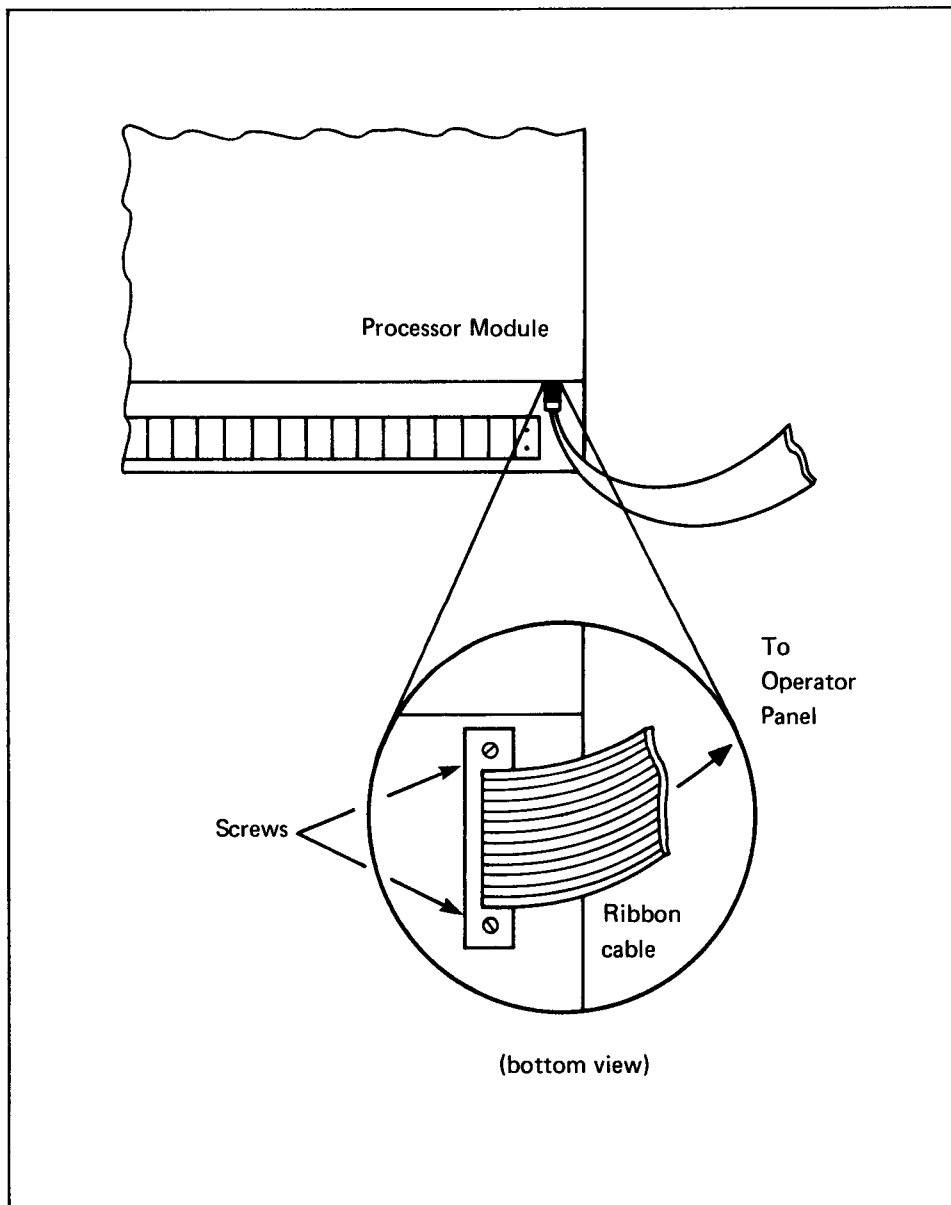

Figure 8.2 – Ribbon Cable Connector

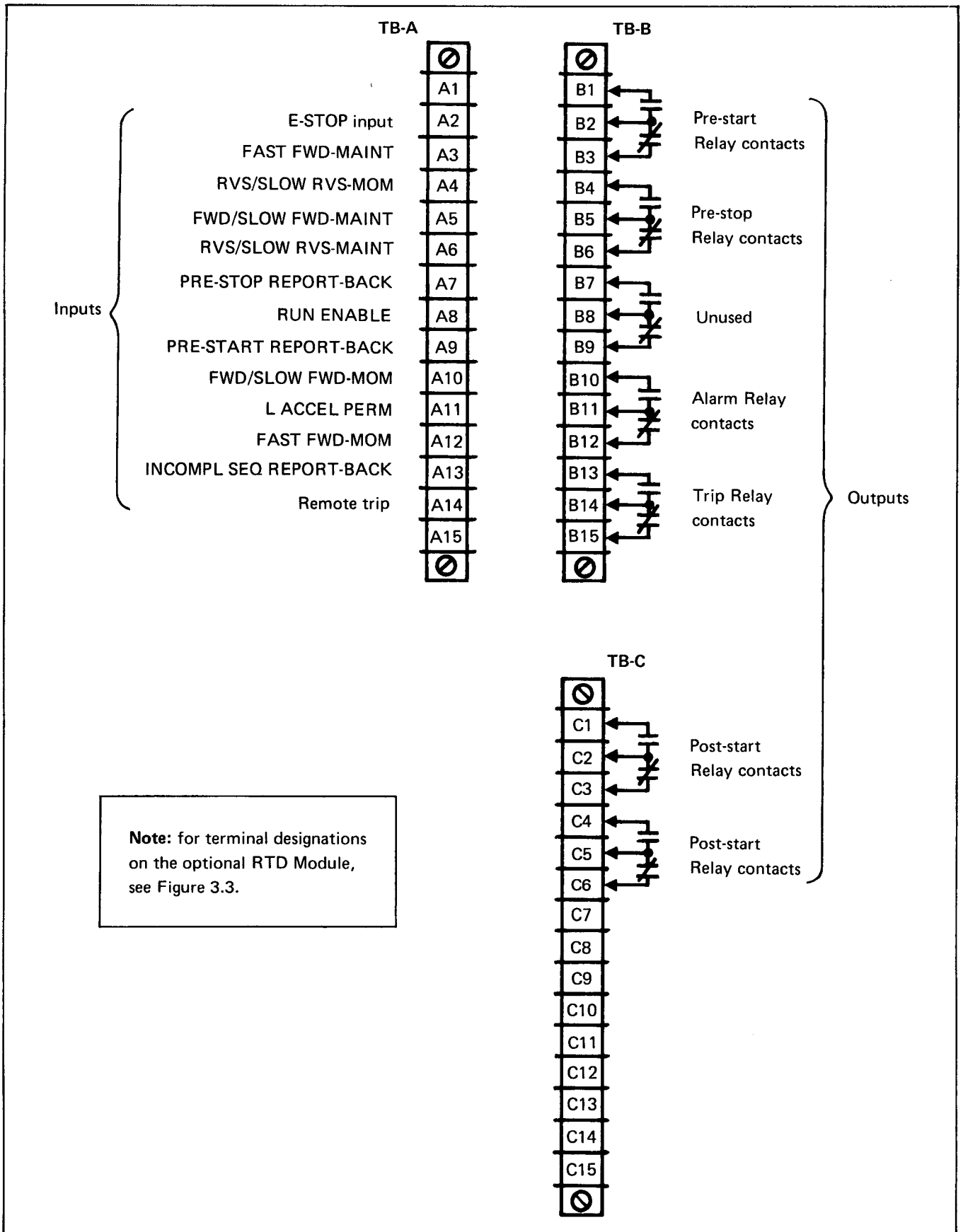

Figure 8.3 – Terminal Designations

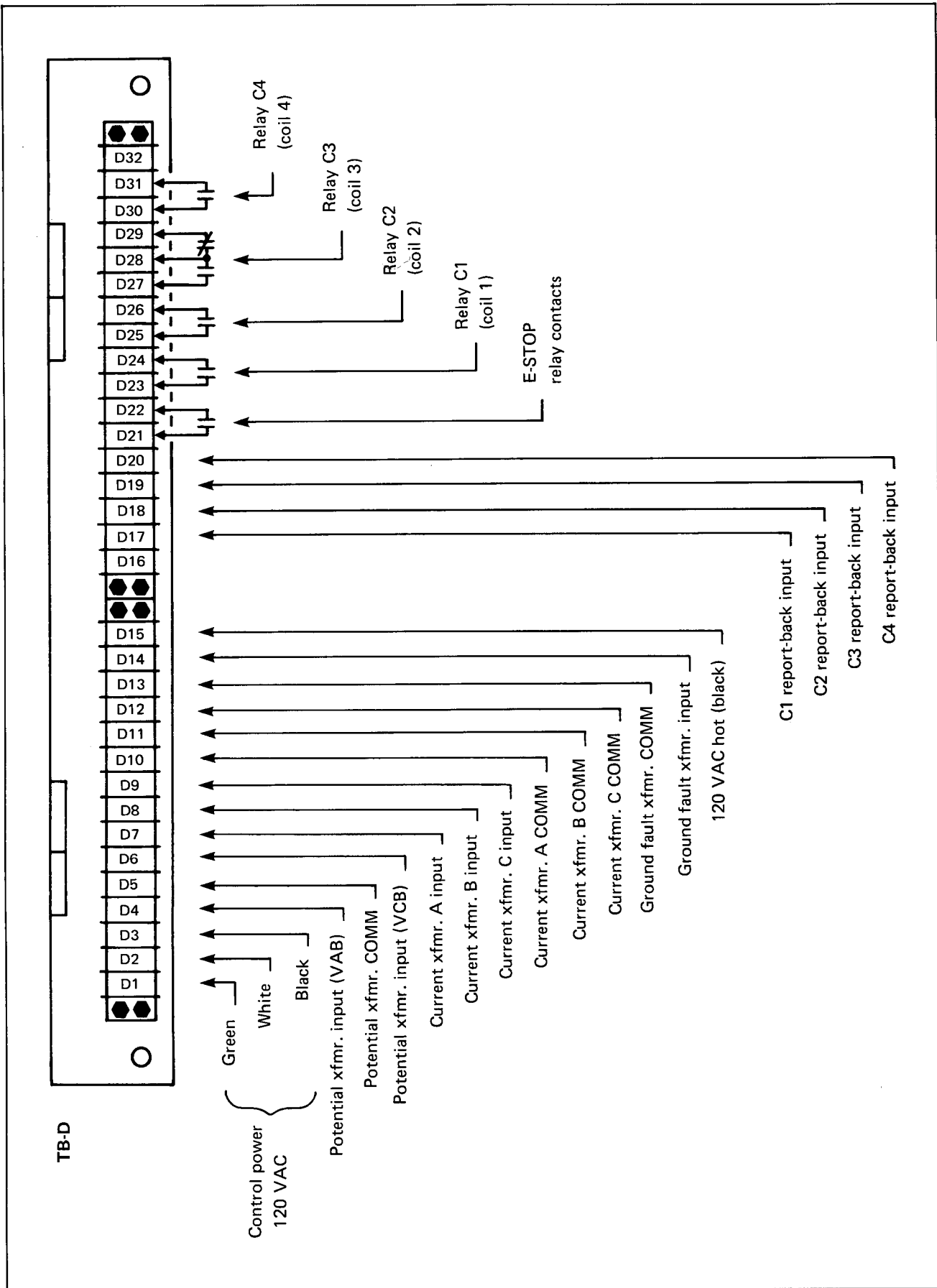
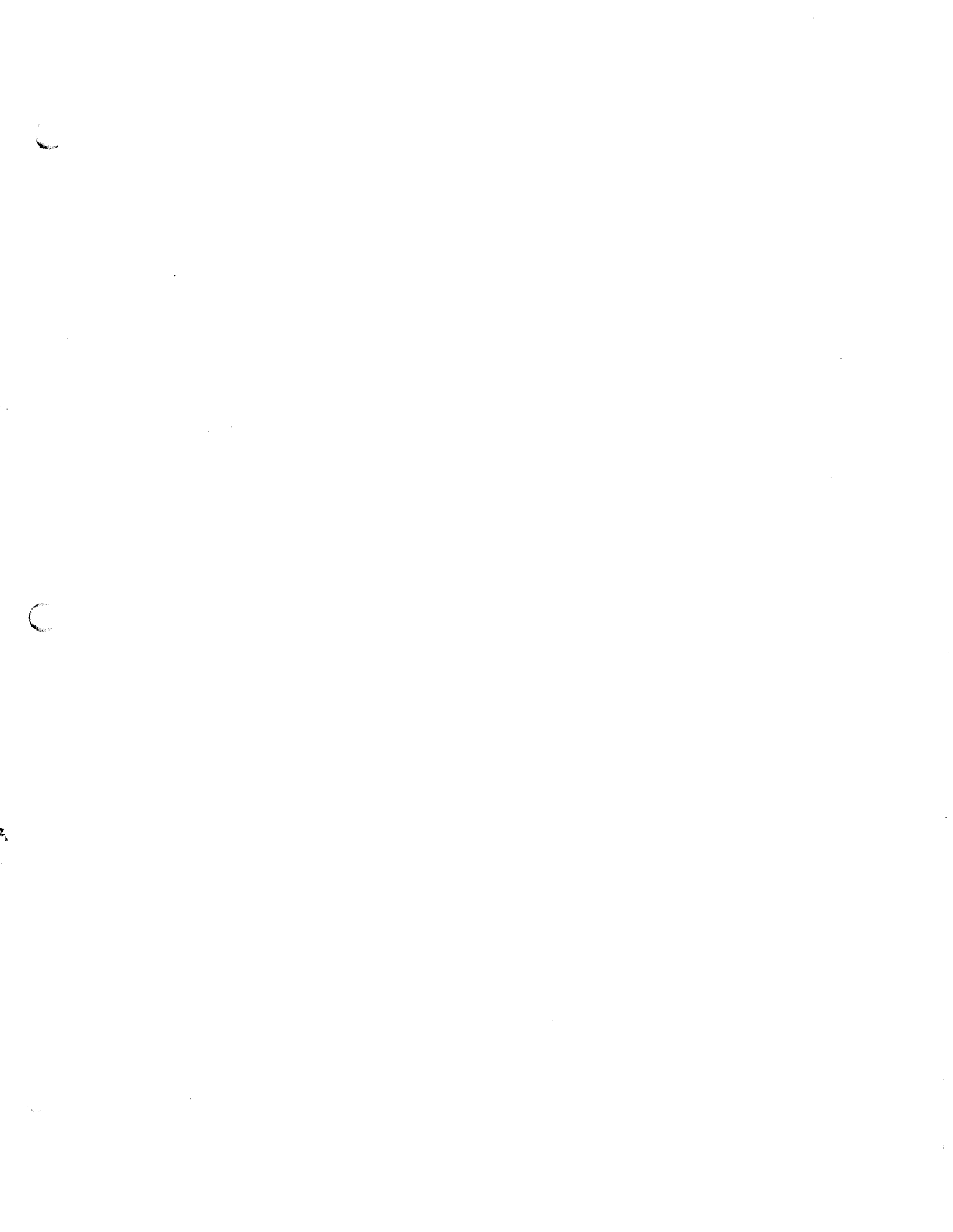

Figure 8.3 -- (Cont'd.)





Westinghouse Electric Corporation
Control Division
Asheville, NC 28813

