

Westinghouse

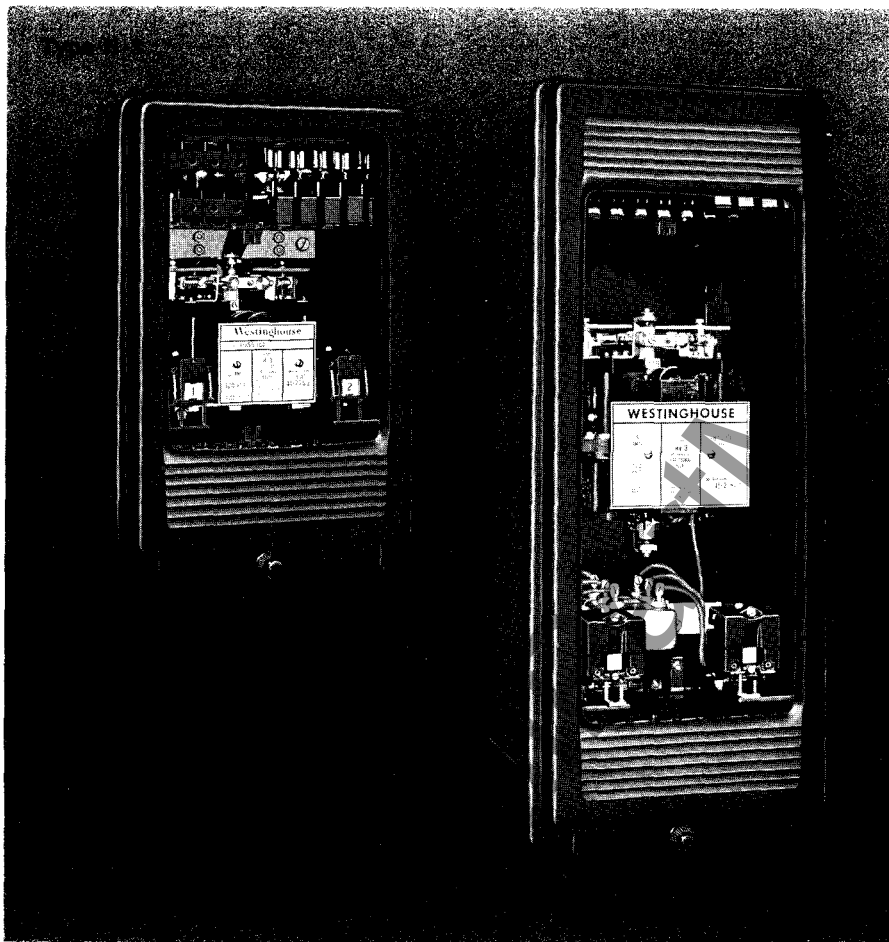

High Speed Directional Relays

Types H-3, HV-3, HV-4
Three-Phase



Application

Types H-3 and HV-3

These relays operate from three-phase voltage and current to provide high-speed directional discrimination during faults on power systems.

The direction of power flow for both phase and ground faults can be detected by the H-3 or the HV-3. To assure correct operation during ground faults, it is necessary that the minimum line-to-ground current be at least three times the maximum load current. Thus, if the fault and load current flow is in opposition, the fault current will produce sufficient net torque to assure correct relay operation.

Low ground current occurs most frequently on impedance grounded systems. If positive directional indication cannot be obtained under all system conditions, a separate ground directional relay is recommended.

Included in the HV-3 is an additional voltage restraint unit (see figure 2) which creates restraining torque on the relay in proportion to the area of the applied voltage triangle. Consequently, at normal system voltage, sufficient torque is produced to prevent HV-3 operation during load current flow. Upon occurrence of a fault, current in the HV-3 increases, and the relay closes its contact if the fault location is in the contact closing direction. Since system voltage does not decrease as much during ground faults as during phase faults, it is desirable to remove voltage restraint during ground faults. This can be accomplished by having an instantaneous overcurrent ground relay (Type SC) open its "break" contact to remove voltage restraint from one of the voltage restraint units.

Both the H-3 and HV-3 relays can be supplied with either a watt characteristic (applied voltage and current in phase for maximum torque) or with a 45° characteristic (applied voltage lagging current by 45° for maximum torque).

The H-3 relay with watt characteristic is frequently used to detect reverse power conditions and prevent "motoring" of generators, or to trip a circuit breaker when power flow is in the undesired direction.

Type HV-4

The HV-4 is a voltage high-speed polyphase angle relay used in motor transfer schemes to initiate transfer of the motor load to an alternate supply source when a predetermined phase angle exists between the motor residual voltage and the alternate supply source.

March, 1969
Supersedes DB 41-225 dated May, 1968
E, D, C/2014/DB

Application Guide^①

Relay	Application and Maximum Torque Angle	Rating: Ac		Operation Indicator	Contactor Switch (CS)	Indicating Contactor Switch (ICS)	
		Amps	Volts				
			Line-Line	Line-Neutral			
H-3	Line Protection I leads V by 45°	5	120 208	1.0 amp dc	1.0 amp dc	...
	Generator Projection (Watt Relay) I in phase with V		70 120			
HV-3	Power Flow (Direction) With Voltage Restraint I leads V by 45°	5	120	0.2/2.0 amp dc
HV-4	Voltage (Phase Angle) V ₁ leads V ₂ by 55°	...	120	...	0.2 amp dc	1.0 amp dc	...

^① Single-pole double-throw contacts, 60 hertz. All relays have electrically independent contacts, circuit-opening and circuit-closing.

Device Numbers

H-3.....	32
HV-3.....	32
HV-4.....	78

Westinghouse

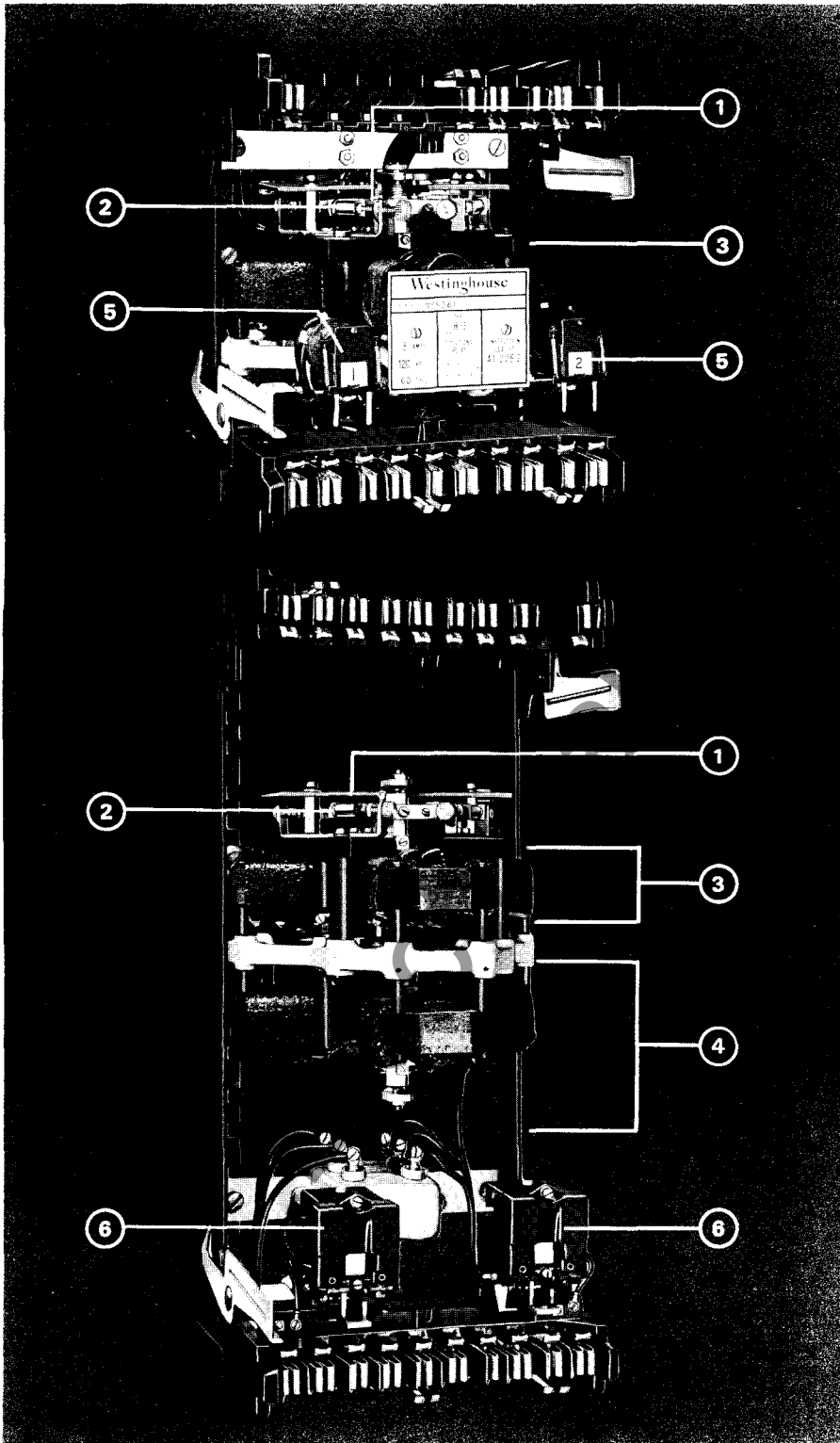

Construction and Operation

Types H-3 and HV-4

Consist of a polyphase directional unit (with current coil applied to the center leg of each electromagnet in the H-3, and voltage coil applied in the same manner in the HV-4) two seal-in contactor switches (CS1 and CS2) and two operation indicators. (See figures 1 and 2.)

Type HV-3

Has a polyphase directional unit, a voltage restraint unit, and two Indicating Contactor Switches.

1 Stationary Contact

2 Moving Contact

Will close 30 amperes at 250 volts dc Normally closed (front view) on H-3.

3 Polyphase Directional Unit

4 Voltage Restraint Unit (HV-3 Only)

5 Operation Indicators

6 Indicating Contactor Switch

Targets drop to indicate tripping operation.

Contactor Switches (H-3 Only)

Seal-in the relay trip circuit after the main contact has closed. Will carry 30 amperes at 250 volts dc until the breaker is tripped and the auxiliary "a" switch opens.

Directional Unit H-3 and HV-3

Upon occurrence of a fault, causes rotation of the relay contact shaft in accord with the direction of system power flow.

HV-4

Interaction of the alternate source and motor load residual voltages directs rotation of the moving contact shaft in a direction determined by the phase angle between the two voltages.

W

High Speed Directional Relays

Types H-3, HV-3, HV-4
Three-Phase

H-3 and HV-3 Directional Unit Phase Angle Characteristics

Figure 3 shows typical phase angle curve of the directional unit for 45° characteristic, 60 hertz relays with balanced three-phase power with no spring restraint applied. Zero torque line at various three-phase current values and at 2 volts and 115 volts of applied delta voltage is shown along the two voltage reference lines. Maximum torque occurs when applied current leads applied voltage by 45°, using the 90° connection.

For the 45° relay characteristic, the standard 90° connection is used to provide wye current and delta voltage. Maximum torque occurs when system fault current lags its unity power factor position by 45°.

The watt relay characteristic utilizes wye current and wye voltage, and maximum torque occurs when voltage and current are in phase.

H-3 relay has adjustable spring restraint to hold relay contacts in non-trip position when relay is de-energized, prohibiting incorrect operation upon loss of load.

HV-4

Maximum torque occurs when voltage of the directional unit's center leg leads that of its outer leg by 55°, with balanced voltages applied and positive on polarity of all coils.

HV-3 Voltage Restraint Unit

At 115 volts this unit's torque is balanced by the torque of the directional unit, with 10 amperes, 115 volts applied (voltage lagging current by 45°). See figure 4.

Torque produced is proportional to the area of the voltage triangle. If a system fault completely collapses, one or more of the voltages, the restraint is removed.

Also, a partial decrease of one or more voltages reduces the restraint torque in direct proportion to the area decrease of the voltage triangle. Internal construction assures uniform restraint torques and balanced burdens.

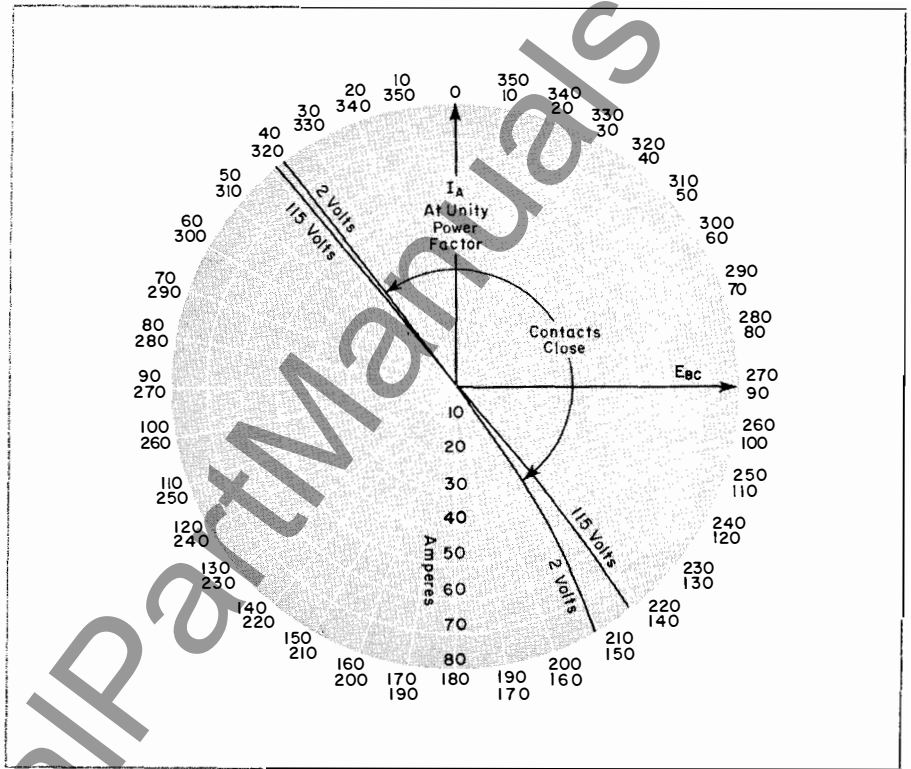

Fig. 3

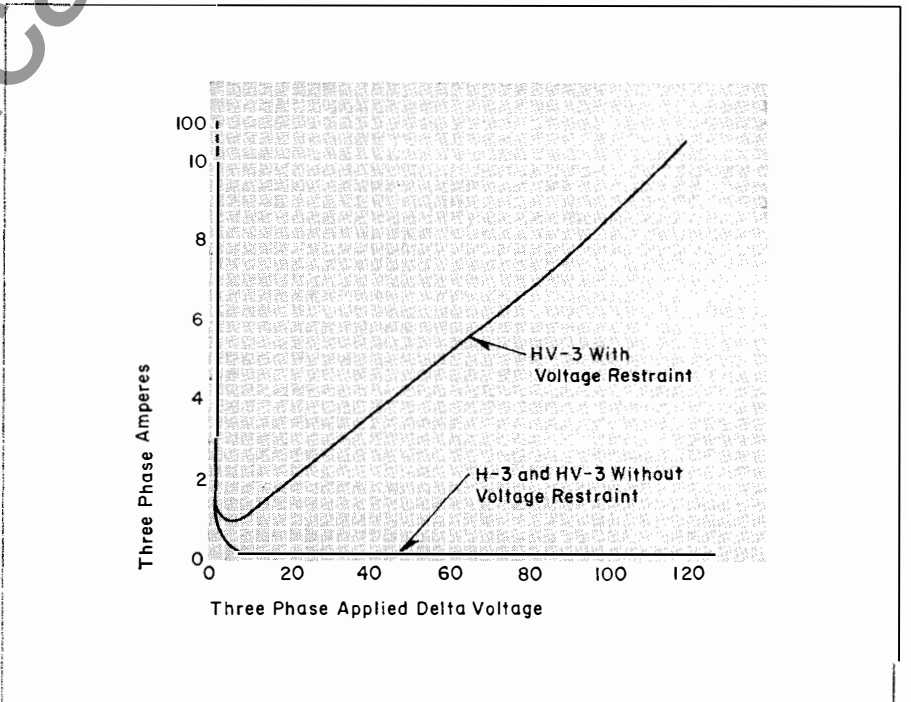

Fig. 4

Westinghouse



**Time Curves For 50 and 60 Hz H-3 and HV-3 Relays (Based on Relay Contact Opening of .035 Inch)[Ⓢ]
For Both Watt and 45° Characteristic Relays At Maximum Torque Angle**

H-3 Relay at Maximum Torque Angle, For Three-Phase Faults

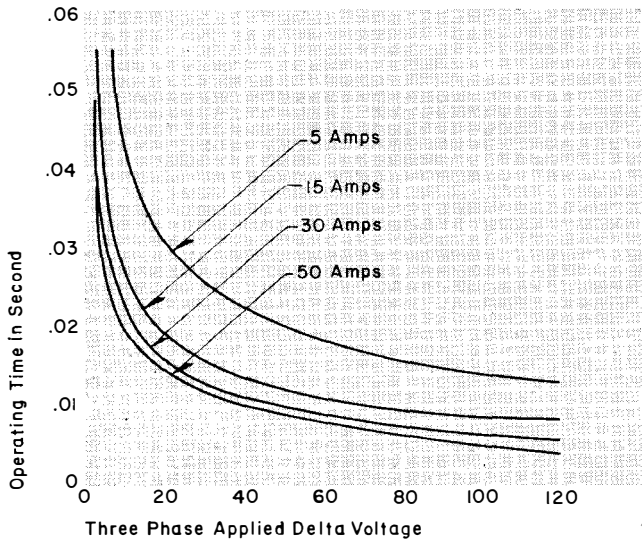

Fig. 5 252133

HV-3 Relay at Maximum Torque Angle, Without Voltage Restraint, For Three-Phase Faults

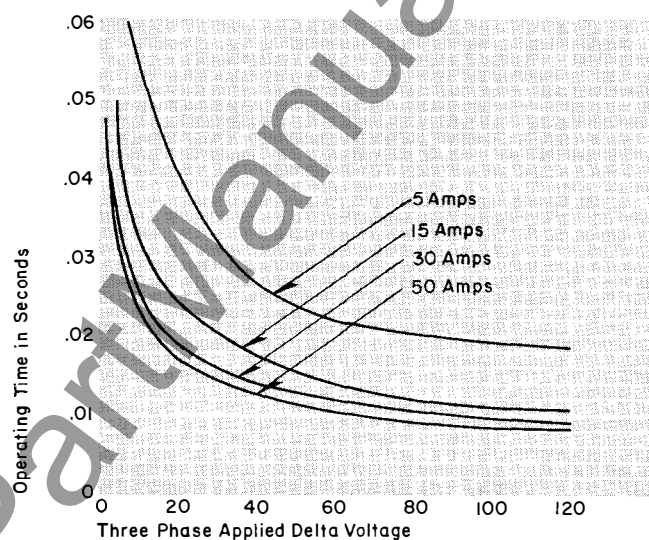

Fig. 6 252144

HV-3 Relay at Maximum Torque Angle, With Voltage Restraint, For Three-Phase Faults

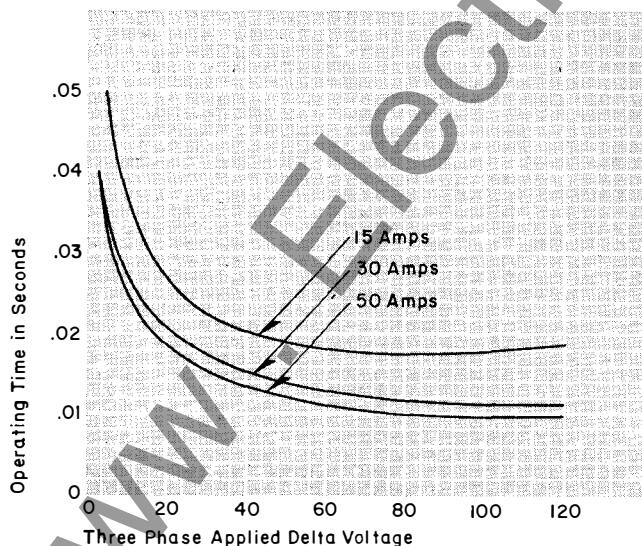

Fig. 7 252145

H-3 and HV-3 Relays at Maximum Torque Angle, Without Voltage Restraint, For Phase-to-Phase Faults (Full Voltage Collapse on Faulted Phase, 86% Voltage on Unfaulted Phase)

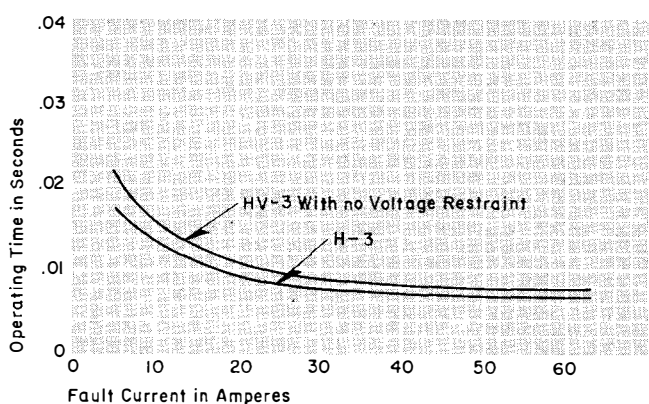

Fig. 8 252146

Ⓢ Refer to figures 12 through 15 for applications involving . . .
 (a) phase-fault parallel line protection
 (b) torque control of overcurrent relays
 (c) directional discrimination (H-3 and HV-3)

High Speed Directional Relays

Types H-3, HV-3, HV-4
Three-Phase

Characteristics

Types H-3 and HV-3

Minimum Pickup Values

H-3: 60 hertz three-phase minimum pickup without spring restraint is 0.08 ampere at 115 volts; 0.15 ampere at 10 volts; and 5.0 amperes at 1 volt. Single-phase minimum pickup currents are approximately three times of those of the three-phase values.

HV-3: Figure 4 indicates that the sensitivity of the HV-3 with voltage restraint decreases only at voltages above 2 volts. 60 hertz at 120 volts are required to overcome this voltage restraint.

Burden and Rating Data

45° Characteristic Values For 120 Volts, 5 Amperes, 60 Hertz

	H-3		HV-3		
	Current Circuit	Voltage Circuit	Current Circuit	Voltage Circuit (Directional)	Voltage Circuit
Resistance: Ohms.....	0.050	2070	0.050	2070	1480
Reactance: Ohms.....	0.052	1530	0.052	1530	1840
Impedance: Ohms.....	0.072	2580	0.072	2580	2360
Watts.....	1.25	4.59	1.25	4.59	3.84
Vars.....	1.29	3.40	1.29	3.40	4.75
Volt-Amperes.....	1.82	5.71	1.82	5.71	6.10
Power Factor.....	46° lag	36.5° lag	46° lag	36.5° lag	51° lag
Continuous Rating (Amperes or Volts)..	5	120	5	120	120
One-Second Current (Amperes).....	240	...	240

Type HV-4

Operating Speed

Polyphase Voltage Unit: Within 35 milliseconds at maximum torque angle, with 120 volts on one set of coils and 80 volts on the other.

Under same conditions, except $\pm 75^\circ$ from maximum torque angle, operation is within 50 milliseconds.

Sensitivity

Relay will operate if 120 volts is applied to one set of coils and 2 volts to the other, at maximum torque angle with one of the relays' three electromagnets energized.

Coils

Rated 132 volts, 60 hertz, continuous.

Burden (Per Phase at 120 Volts, 60 Hertz)

Outer Leg Coils: 1.8 volt-amperes.

Center Leg Coils: 5.1 volt-amperes.

Trip-Circuit Data (For All Types)

Coil Only	Relay Type	Rating: Amps, Dc	Resistance: Ohms, Dc	Amps	
				Continuous	1 Second
Operation Indicator	H-3, HV-4	1.0	.16	2.5	70
Contact Switch (CS)	H-3, HV-4	1.0	.84	1.9	28
Indicating Contact Switch (ICS)	HV-3	0.2 tap	6.5	0.4	11.5
		2.0 tap	0.15	3.2	88.0

Westinghouse



Internal Wiring (Front View)

H-3 Relay, FT-22 Case

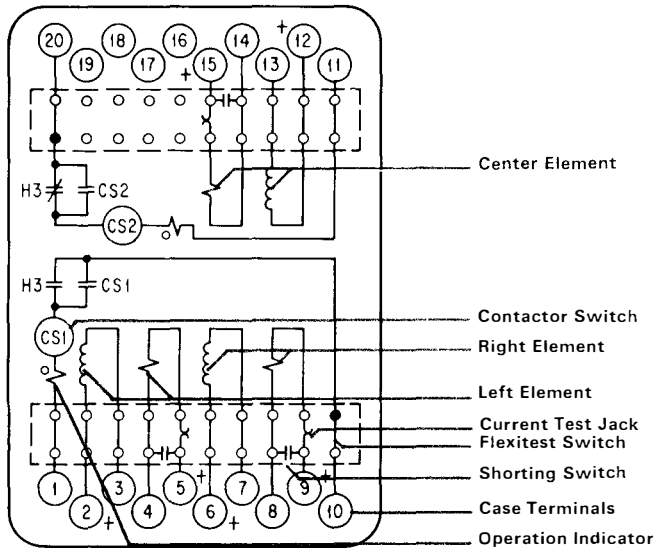

With relative instantaneous polarities as shown, the make contact closes and the moving element rotates counter clockwise (top view).

Fig. 9

183A355

HV-3 Relay, FT-32 Case

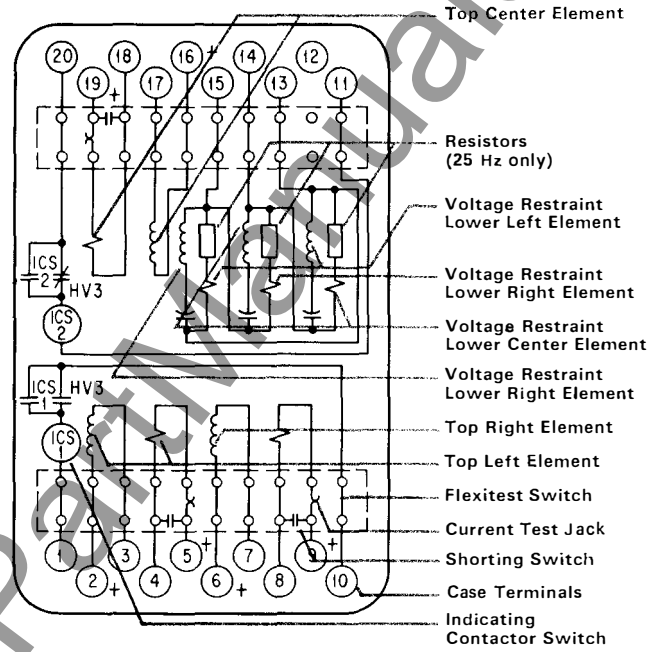

With relative instantaneous polarities as shown, the make contact closes and the moving element rotates counter clockwise (top view). Voltages on restraint elements as shown with phase rotation A, B, C rotate the moving element clockwise (top view).

Fig. 10

182A751

HV-4 Relay, FT-22 Case

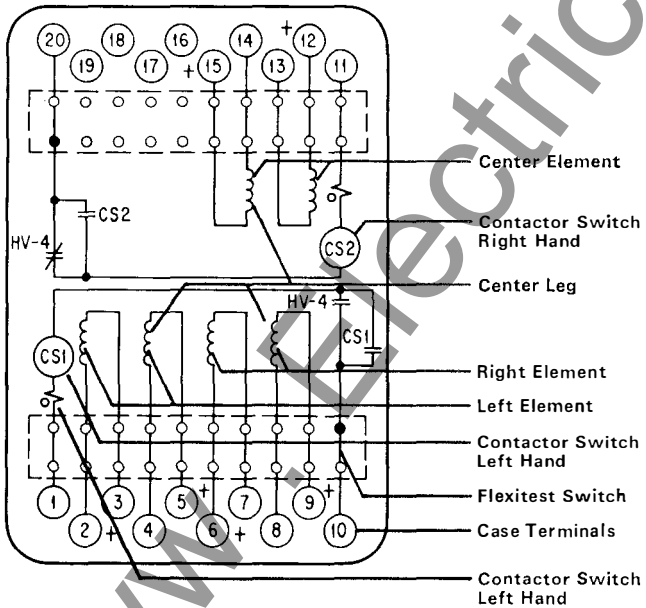

With relative instantaneous polarities as shown, the make contact closes and the moving element rotates counter clockwise (top view).

Fig. 11

188A346

High Speed Directional Relays

Types H-3, HV-3, HV-4
Three-Phase

External Wiring

H-3 Relay, Watt Connection

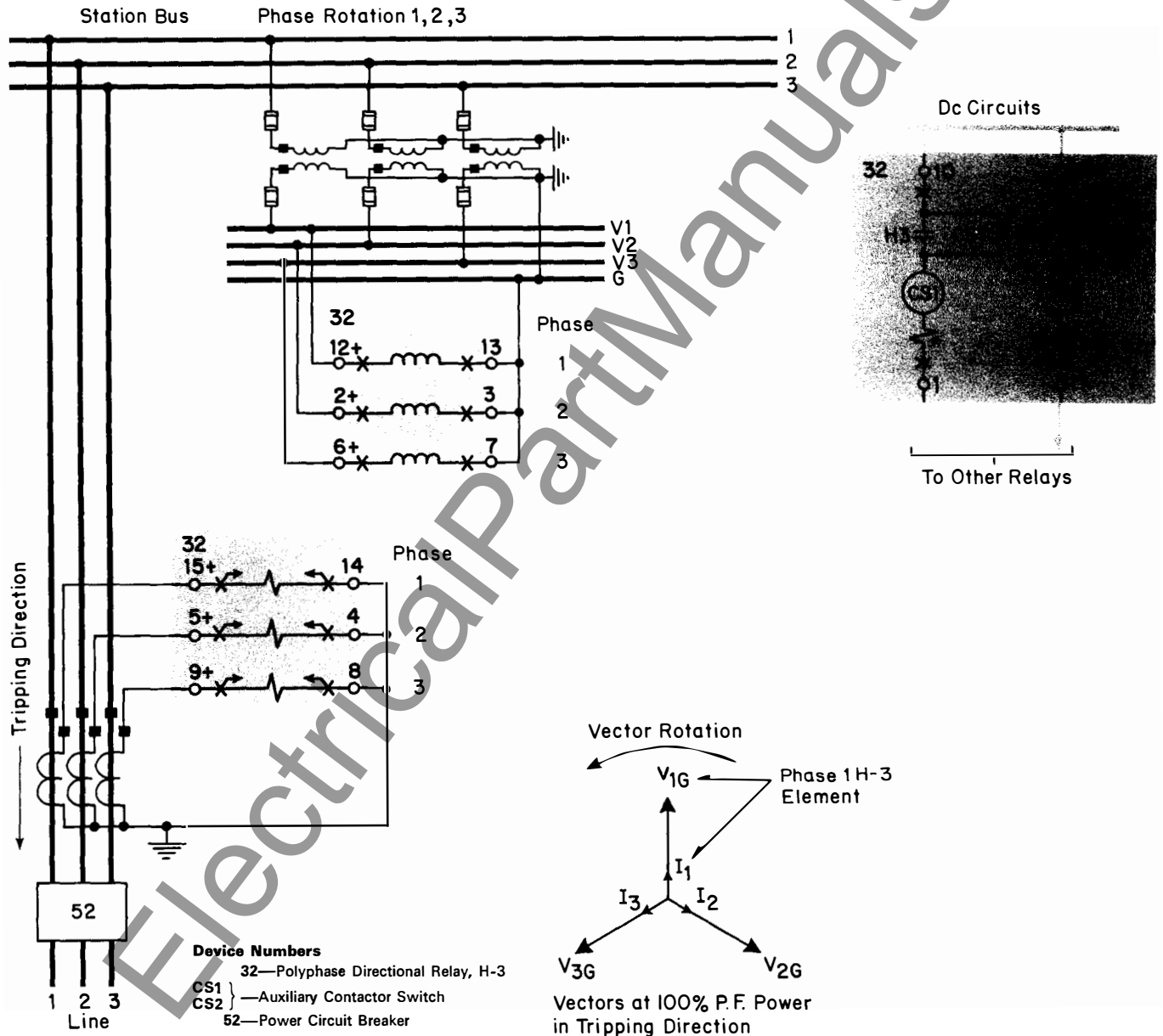

Fig. 12

Westinghouse



External Wiring

H-3 Relay, Directional Overcurrent Phase Protection Of A Three Phase Line Using Three Type CO Torque Controlled Relays, Directionally Controlled By One Type H-3 And One Type MG-6 Relay

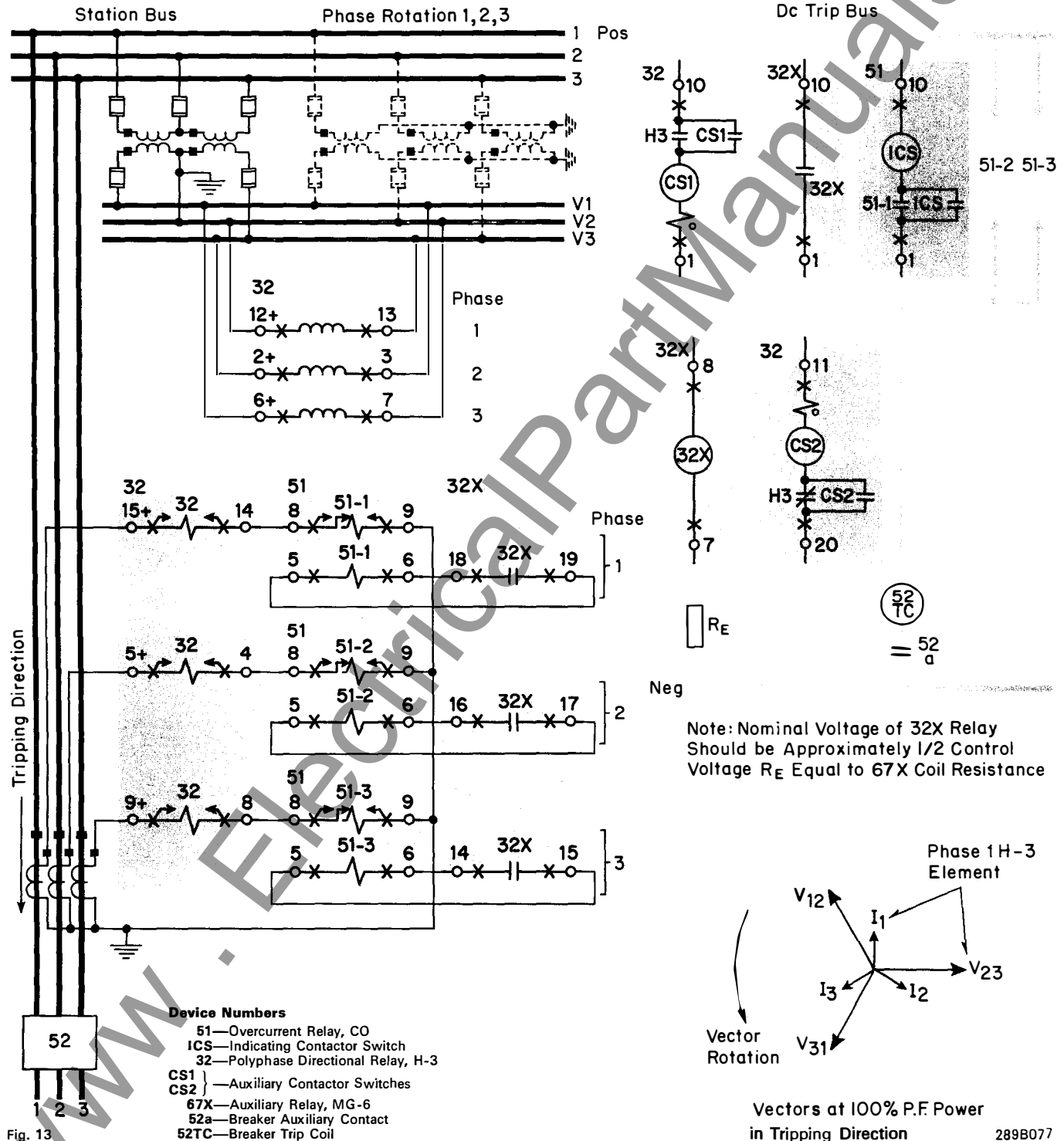

Fig. 13

Device Numbers

- 51—Overcurrent Relay, CO
- ICS—Indicating Contactor Switch
- 32—Polyphase Directional Relay, H-3
- CS1 } —Auxiliary Contactor Switches
- CS2 }
- 67X—Auxiliary Relay, MG-6
- 52a—Breaker Auxiliary Contact
- 52TC—Breaker Trip Coil

High Speed Directional Relays

Types H-3, HV-3, HV-4
Three-Phase

External Wiring

H-3 Relay and 3-Unit SC, For Phase Fault Parallel Line Protection, 90° Connection
Station Bus Phase Rotation 1, 2, 3

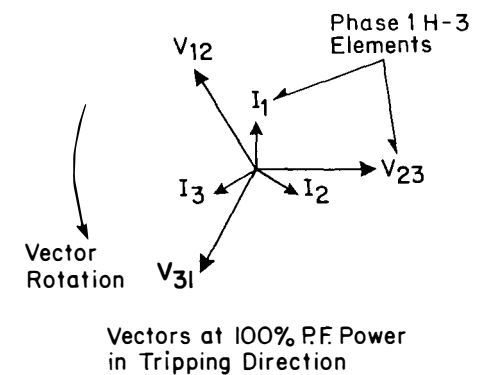
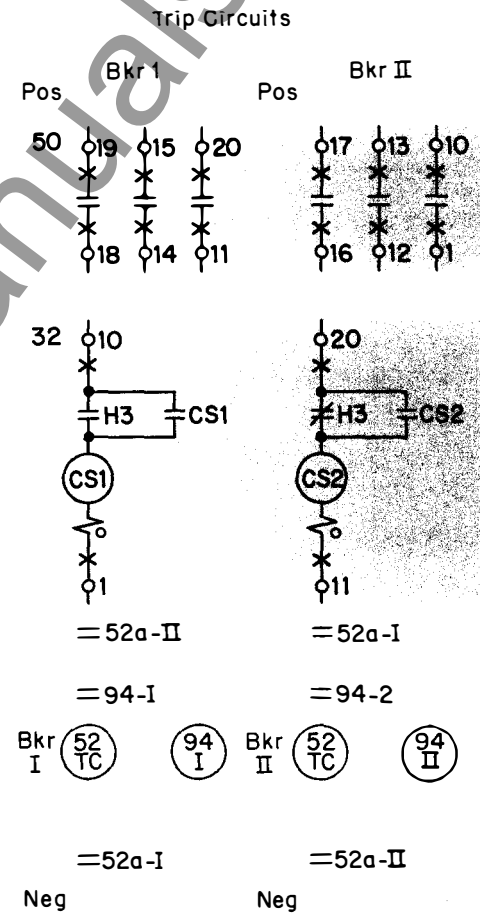
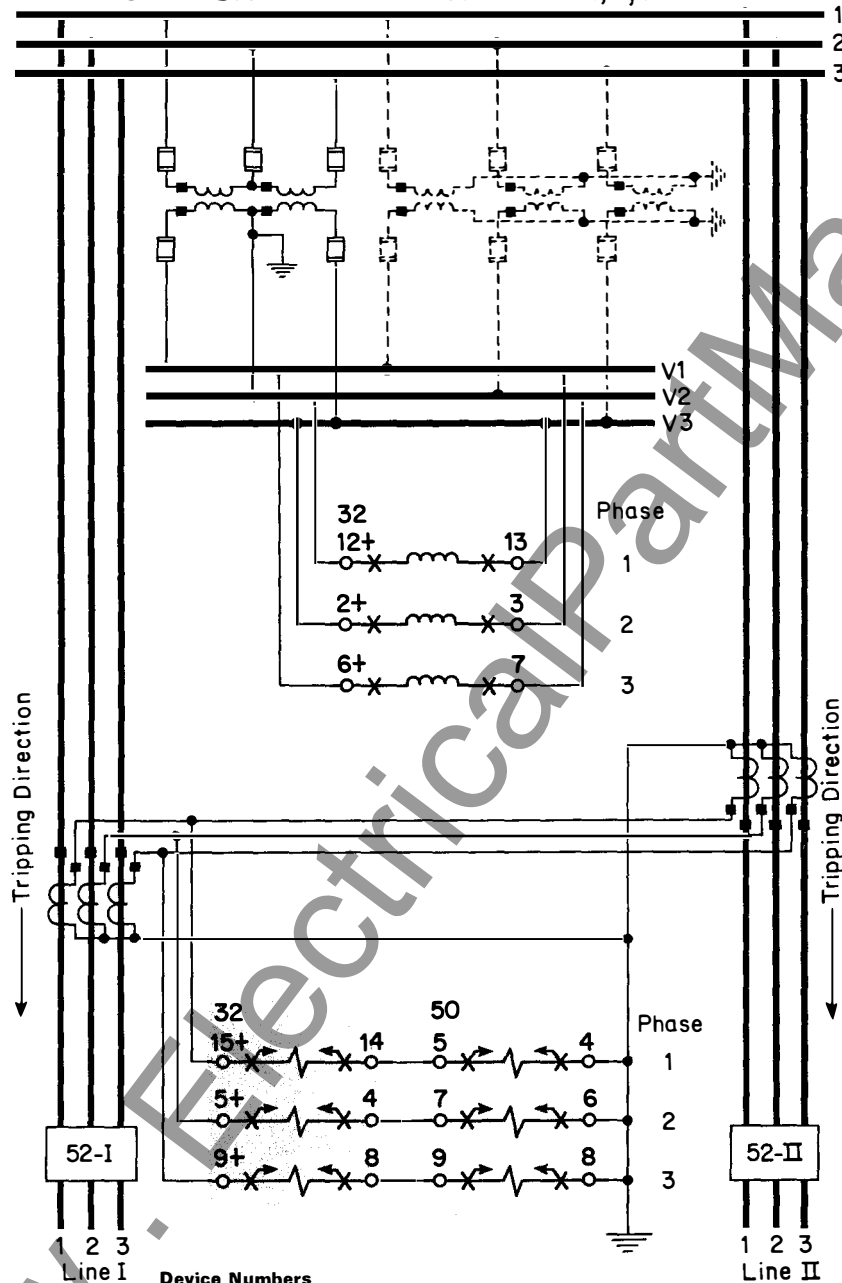

- Device Numbers**
- 50—Instantaneous Overcurrent Relay, SC (3-Unit)
 - 32—Polyphase Directional Relay, H-3
 - CS1 } —Auxiliary Contactor Switches
 - CS2 }
 - 94—Auxiliary Tripping Relay, SG
 - 52—Power Circuit Breaker
 - 52a—Breaker Auxiliary Contact
 - 52TC—Breaker Trip Coil

Fig. 14

Westinghouse



External Wiring
HV-3 Relay, 90° Connection

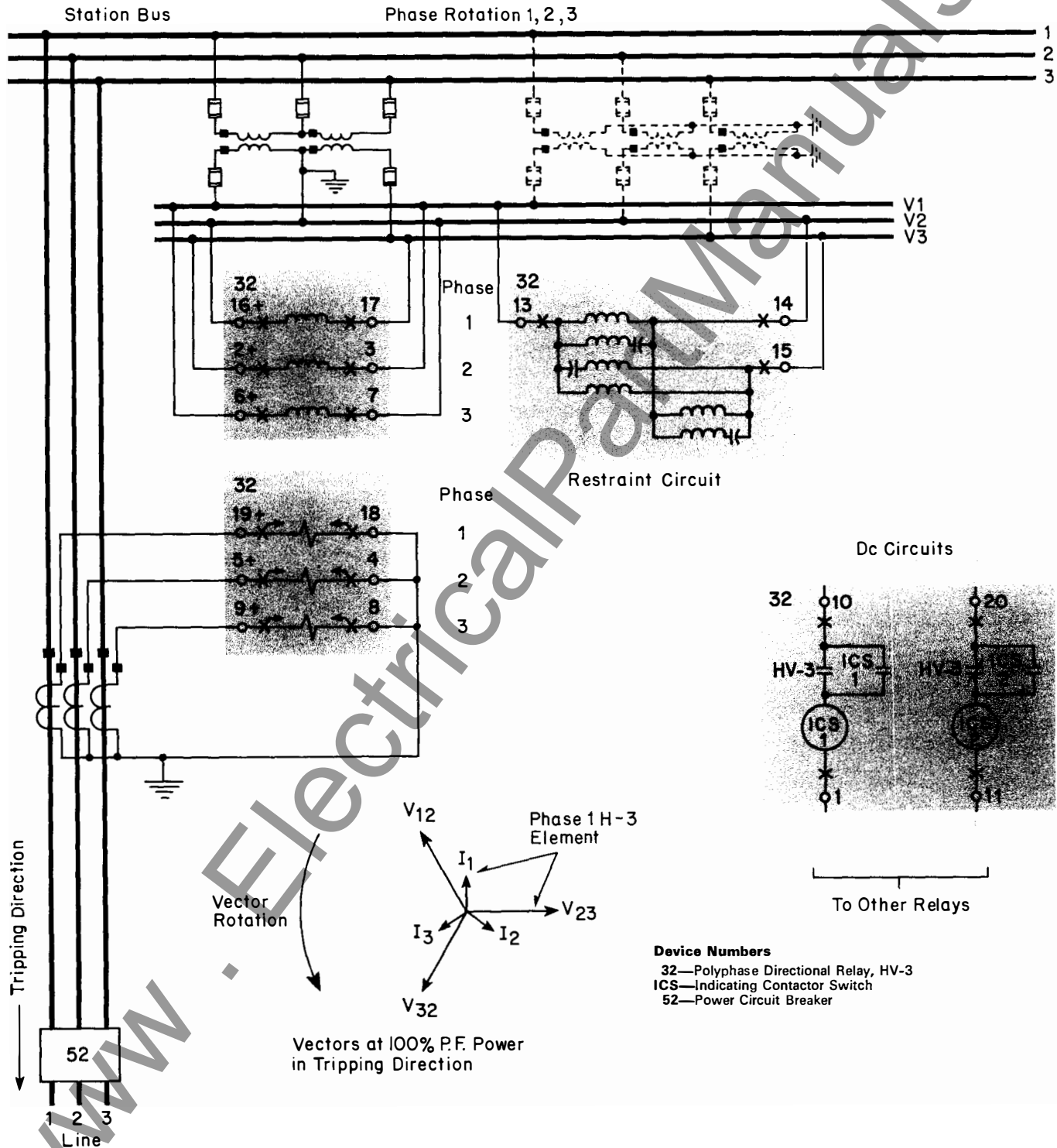
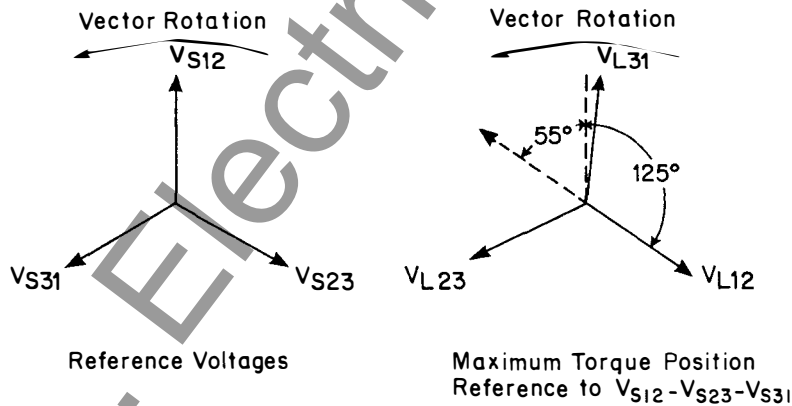
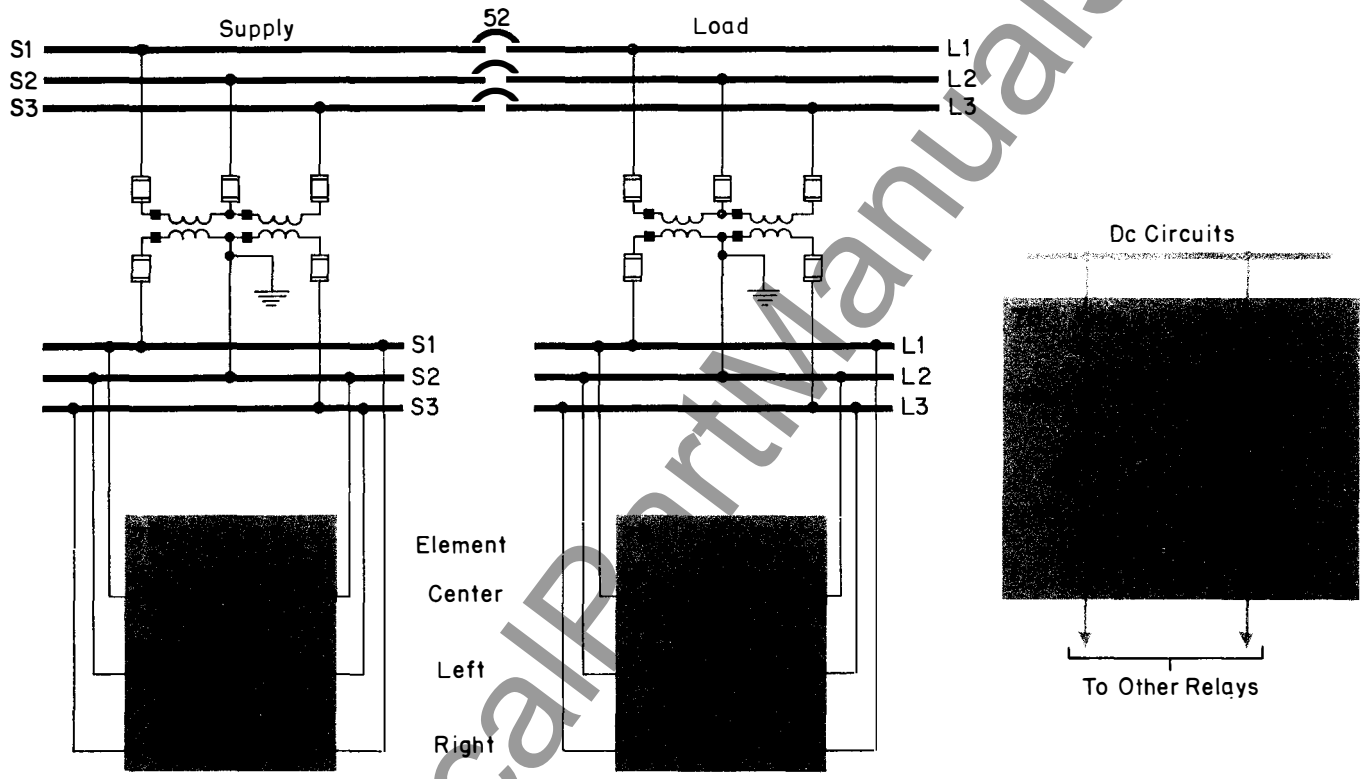

Fig. 15

High Speed Directional Relays

Types H-3, HV-3, HV-4
Three-Phase

External Wiring HV-4 Relay, Motor Transfer Scheme



Device Numbers

- 78—Voltage Phase Angle Relay, HV-4
- CL—Center Leg Coil
- OL—Outer Leg Coil
- 52—Power Circuit Breaker

“Make” contact closes with voltages as shown. Indicated maximum torque position is based on balanced conditions with 1-2-3 rotation as shown, or with 1-3-2 rotation.

Fig. 16

High Speed Directional Relays

Types H-3, HV-3, HV-4
Three-Phase

Weights and Carton Dimensions

Relay Type	Case Type	Weight: Lbs, Approx.		Domestic Shipping Carton Dimensions: Inches
		Net	Shipping	
H-3, HV-4	FT-22	12	15	9 x 12 x 13
HV-3	FT-32	14	17	13 x 13 x 21

Further Information

Prices: PL 41-020

Instructions: IL 41-226.2 (H-3, HV-3)
IL 41-228.1 (HV-4)

Renewal Parts: RPD 41-419 (H-3, HV-3)

Other Relays: SG 41-000