



ABB Inc.
Substation Automation and Protection Division
Coral Springs, FL
Allentown, PA

Descriptive Bulletin
41-210M

March 2002

REM 543 Motor Protection Relay

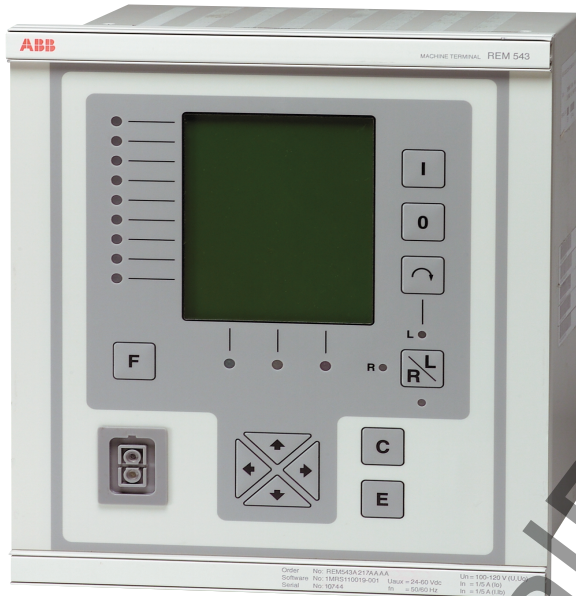

Features

- Broad range of protective functions
- Extensive metering data
- Local and remote control of breaker or motor starter
- Continuous Monitoring/Diagnostics
- Pre-configured Models
- Modbus® Communication Port
- High Quality Design and Construction

Application

The REM 543 is a full-featured microprocessor-based relay for the protection of medium and large sized induction and synchronous motors.

The relay provides multifunction protection, detailed metering, fault records, oscillography, and advanced communications capability.

A large front panel LCD graphical display provides continuous information on the motor status and easy access to records and settings.

A front panel optical RS232 port allows communication to a PC using the CAP501 software tool.

Pre-Configured Models

This brochure describes several preconfigured models for common motor applications, which reduce your engineering and commissioning time.

Your Investment

The combination of REM 543 performance, features, quality, and dependability gives excellent value for your investment in motor protection.

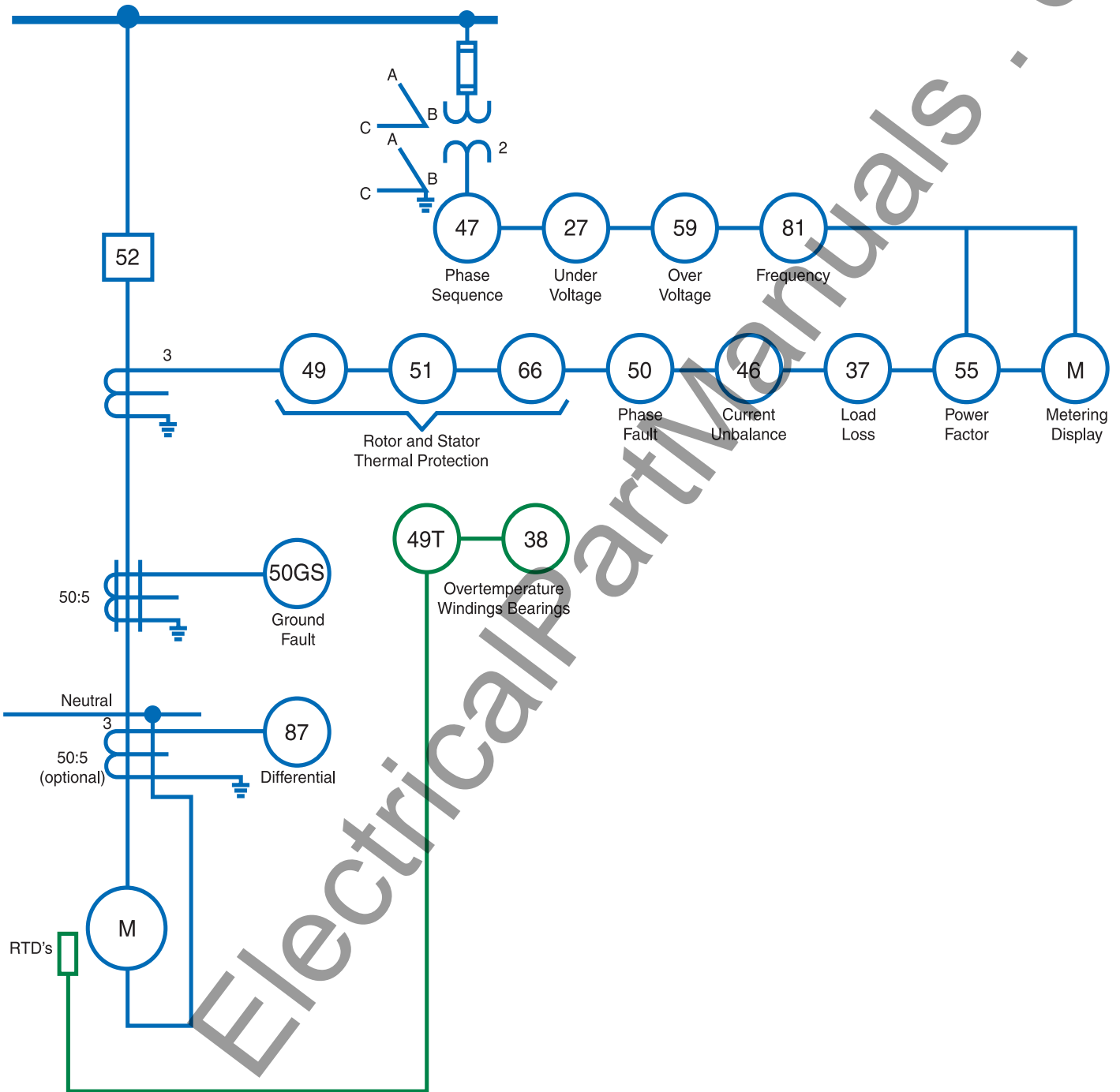

Figure 1: Single-line Drawing

Application

The REM 543 machine terminal provides integrated multi-function protection for medium and large sized induction and synchronous motors used to drive pumps, fans, compressors, mills, crushers etc. Protection is provided for start-up, running, and overload conditions. Thermal modelling is used to estimate rotor and stator thermal condition. An optional RTD input module allows direct reading of stator and bearing temperatures from the RTD's if the motor is so equipped. Motor starts in a given time period can be limited by the relay.

In addition to the protection functions, the unit provides comprehensive measurement, control, and condition monitoring functions. For installations requiring remote communication of metering, status, and control information, a rear port with Modbus protocol is standard.

Design

The REM 543 is organized on the basis of function blocks. There is a particular function block associated with each of the protective elements, and also for the metering, monitoring, and control functions.

Characteristics and specifications for each of the function blocks are shown later in this bulletin and more detailed documentation is given on the CD-ROM "Technical Descriptions of Functions" (1MRS 750889-MCD).

The main purpose of having the pre-configured models shown in this brochure is to remove from the purchaser the task of selecting appropriate function blocks from the extensive library of functions and then making the logical connections between all these function blocks and to the physical inputs and outputs of the hardware platform.

The typical external connections for these pre-configured models are shown in Figures 2, 3 and 4.

Protection Functions

The protection functions are shown in the single-line drawing of Figure 1. These functions may be individually enabled or disabled by the user per the requirements of the application as part of the settings process. Settings modes and ranges are shown in the function block descriptions later in this bulletin.

Thermal Overload Protection, device 49, function block TOL3Dev, uses a two time-constant model for each of the rotor and stator windings of the machine, to estimate their thermal condition under starting, running, overload, and cool-down operation of the motor. Ambient temperature compensation of the thermal models can be provided when the

relay 272M0x01 is used, which has one RTD input assigned to measure the ambient.

Analysis Software: An application aid and analysis program is available that emulates the thermal overload protection function of the REM543. Motor starting and overload conditions can be simulated and the time-current characteristic curve that results from the chosen thermal time constant settings can be drawn for reference.

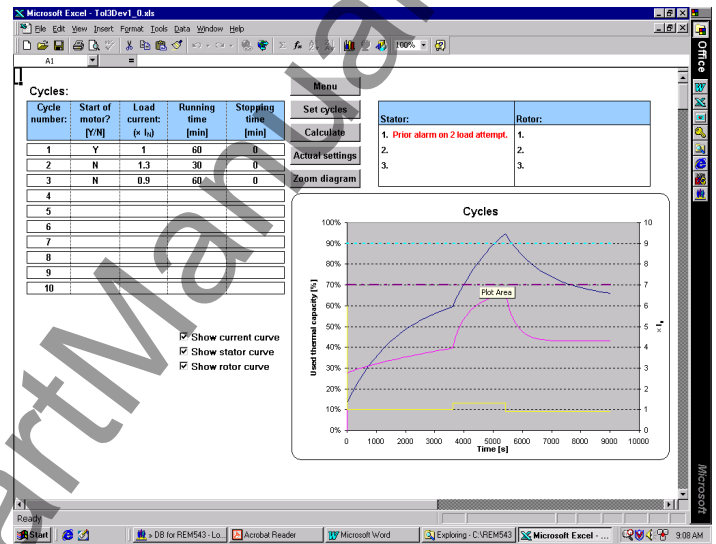

Motor Starting Supervision: A separate function block, device 51/66, MotStart, provides backup to the thermal model for protection during starting, and provides the set limit to the number of starts allowed in a particular time period. When an external speed switch is available, tripping under a locked rotor condition can be initiated prior to reaching the thermal limit of the rotor.

Measurement Functions

The measurement functions include the phase currents, ground current, phase voltages, frequency, active and reactive power, and power factor.

An optional RTD module is used for measuring stator winding, bearing, and ambient temperatures, and allows for various types of resistance temperature detectors.



Waveform Capture

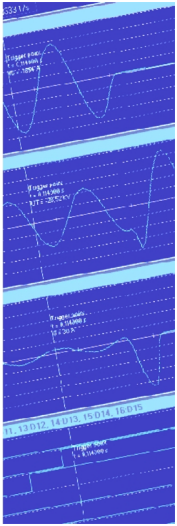

The transient disturbance recorder is able to record 16 current or voltage waveforms and 16 logic digital signals. The sampling frequency of the analog inputs is 2 kHz at the rated frequency of 50 Hz and 2.4 kHz at the rated frequency of 60 Hz.

The user can set the length of a recording within a range determined by the number of analog inputs used. The total number of recordings that can be retained by the relay depends on the sampling frequency, length of recording, and number of analog inputs.

The recordings can be uploaded to your PC with the DR-Collector Tool which converts the data to COMTRADE format.

The DR-Collector Tool is supported in the CAP501 relay software tool.

Control Functions

The control functions are used to indicate the status of the circuit breaker or motor starter, and to allow the local or remote open and close operation of the circuit breaker.

Condition Monitoring Functions

Condition monitoring function blocks such as self-diagnostics, supervision of the energizing current and voltage input circuits, operation time counter, circuit-breaker contact wear, scheduled maintenance, trip circuit supervision, and breaker travel time are provided.

Communication Functions

The REM 543 provides an optical RS232 front port for communicating to a PC that is running the CAP501 software tool. This software tool allows access to all metering and monitoring functions, and to the settings for all of the protection and alarm functions.

The CAP501 tool also allows settings to be made up in advance, without being connected to a relay, and then saved in a file for later downloading to the relay.

Modbus Protocol: an RS232 rear port with Modbus protocol is standard in the preconfigured models offered in this bulletin. An Automation Technical Guide for this protocol, TG 7.11.1.7-73, is available on request.

Typical CAP501 Settings Screen:

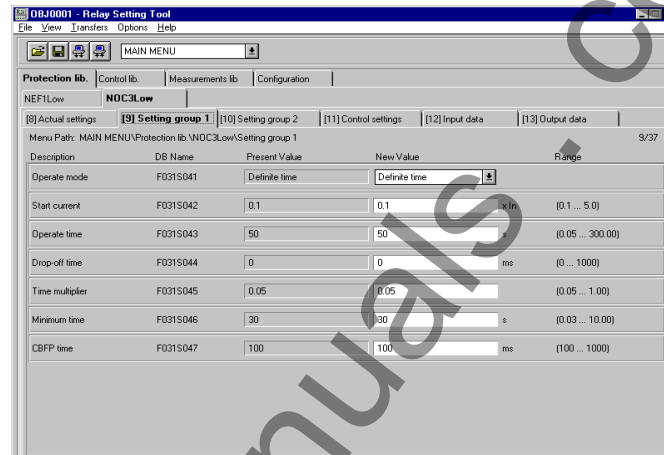

Digital Inputs

The digital inputs of the relay are voltage-controlled and optically isolated. A programmed filter time removes contact bounce and short disturbances on a digital input.

There are two global parameters for the suppression of digital input oscillation. The settings of these parameters determine the level and hysteresis for all digital inputs. An event is generated if oscillation is detected.

For each digital input the status of the input (value), the time tag for the status change (time) and the validity of the digital input (invalidity) are available and are used for various purposes.

RTD Inputs

The REM 543 machine terminal when equipped with the optional RTD module has eight inputs for RTD resistance measurement. The RTD inputs are galvanically isolated from the machine terminal power supply and enclosure; however, the inputs do have a common ground. These inputs are assigned to specific protection functions per the configuration of the unit. Refer to the table of catalog numbers for RTD assignment in the preconfigured units.

Output Contacts

- * HSP0: High-Speed Power Output, rated for circuit breaker tripping and closing.
- * PO: Power Output, rated for circuit breaker tripping and closing.
- * SO: Signal Output, lighter duty contacts for alarm and annunciation purposes.

Trip Circuit and Close Circuit Supervision

This function monitors the continuity of circuit wiring and the trip and close coils of the circuit breaker. An alarm will be generated if a faulty circuit is detected. The supervision is based on the injection and flow of a small trace current from the relay through each of the trip and close circuits.

Self-Diagnostics

The REM 543 is provided with an extensive self-supervision system. When an internal problem has been detected, the green Ready indicator starts blinking and a problem indication text appears on the MMI. At the same time, the machine terminal delivers a signal to change the state of the self-supervision output relay and also blocks the protection trip outputs. In addition, the self-supervision system generates an IRF code indicating the type of the fault. The fault code can be read from the main menu.

Relay Front Panel and Graphic Display

The front display consists of 19 rows divided into two windows: a main window (17 rows) and an assisting window (2 rows at the bottom).

The graphic display presents detailed information on status, targets, events, measurements, alarms, and relay settings. The assisting window is used for indications and alarms and help messages.

Additionally, the front panel includes the following MMI items:

- * Three push-buttons for breaker control: Select (arrow), Close (I), Open (O) .
- * Eight alarm and target LEDs with different colors
- * MMI push-button section with four arrow buttons and buttons for clear and enter
- * Push-button for remote/local control
- * Optically isolated serial communication port
- * Backlight and contrast control

The MMI has two main access levels, the user level and the technical level. The user level is for “everyday” measurements and monitoring of motor and system status, whereas the technical level allows for the changing of relay settings and is password protected. The setting parameters are accessed and chosen by working through a hierarchical menu structure.

User Level Graphic Screens

- * Operating View
- * Metering Screen
- * Target Indicator Legend
- * Event Records

Technical Level Graphic Screens

- * Main Menu
- * Group Menu
- * Subgroup Menu
- * Parameter Menu

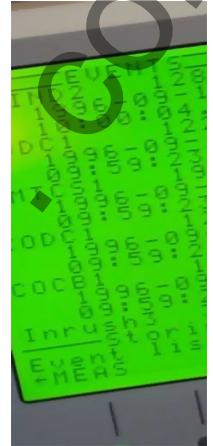

The default Operating View display is set up in the pre-configured models that include RTD inputs, to indicate the following information on the front of the relay during normal operation:

- * Hottest Stator Winding RTD Temperature
- * Hottest Motor Bearing RTD Temperature
- * Hottest Load Bearing RTD Temperature
- * Estimated Time to Allow Restarting (time in seconds after a tripping operation)
- * Estimated Time to a Trip (when the machine is running in an overloaded condition.)
- * A prompt for tripping or closing the breaker using the front panel pushbuttons
- * Motor status: running or stopped

Other display layouts can be easily customized to the user's requirements using the Relay Mimic Editor software. For example, it would be possible to show the breaker status, and motor load current.

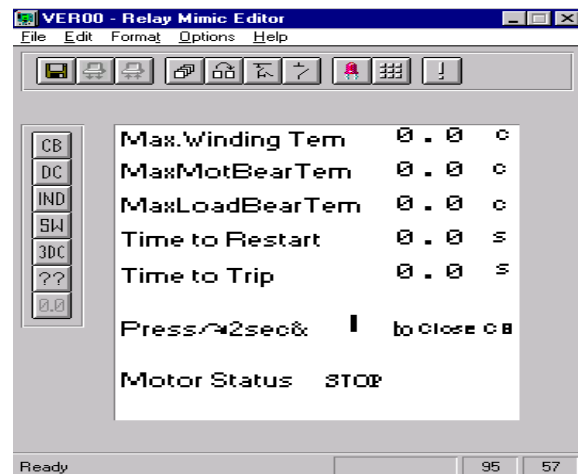

Target and Status Indicators

The nine light-emitting-diode indicators arranged vertically to the left of the graphic display serve as status and trip indicators. Pressing one of the arrow keys brings up on the graphic display the descriptive legend for each of the indicators. Indicators associated with a tripping operation are sealed-in and must be manually reset.

Additional information about a trip or alarm condition is presented in the lower assisting-window portion of the graphic display.

The pre-configured units have the target indicating led's assigned as follows:

- * Trip Circuit Supervision
- * Hot RTD
- * Restart Inhibit (Red) /Restart Enable (Green)
- * Loss of Load
- * Back Up Trip
- * Overload Trip
- * Differential / Overcurrent Trip
- * Ground Fault Trip
- * Interlock Active



Front Panel Control Pushbuttons

- * Local/Remote Control Selection
- * Trip and Close of the Circuit Breaker requiring Select and Execute Sequence

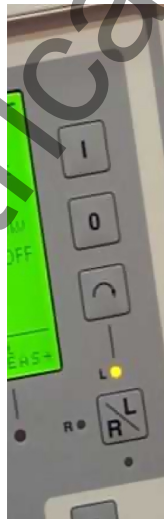

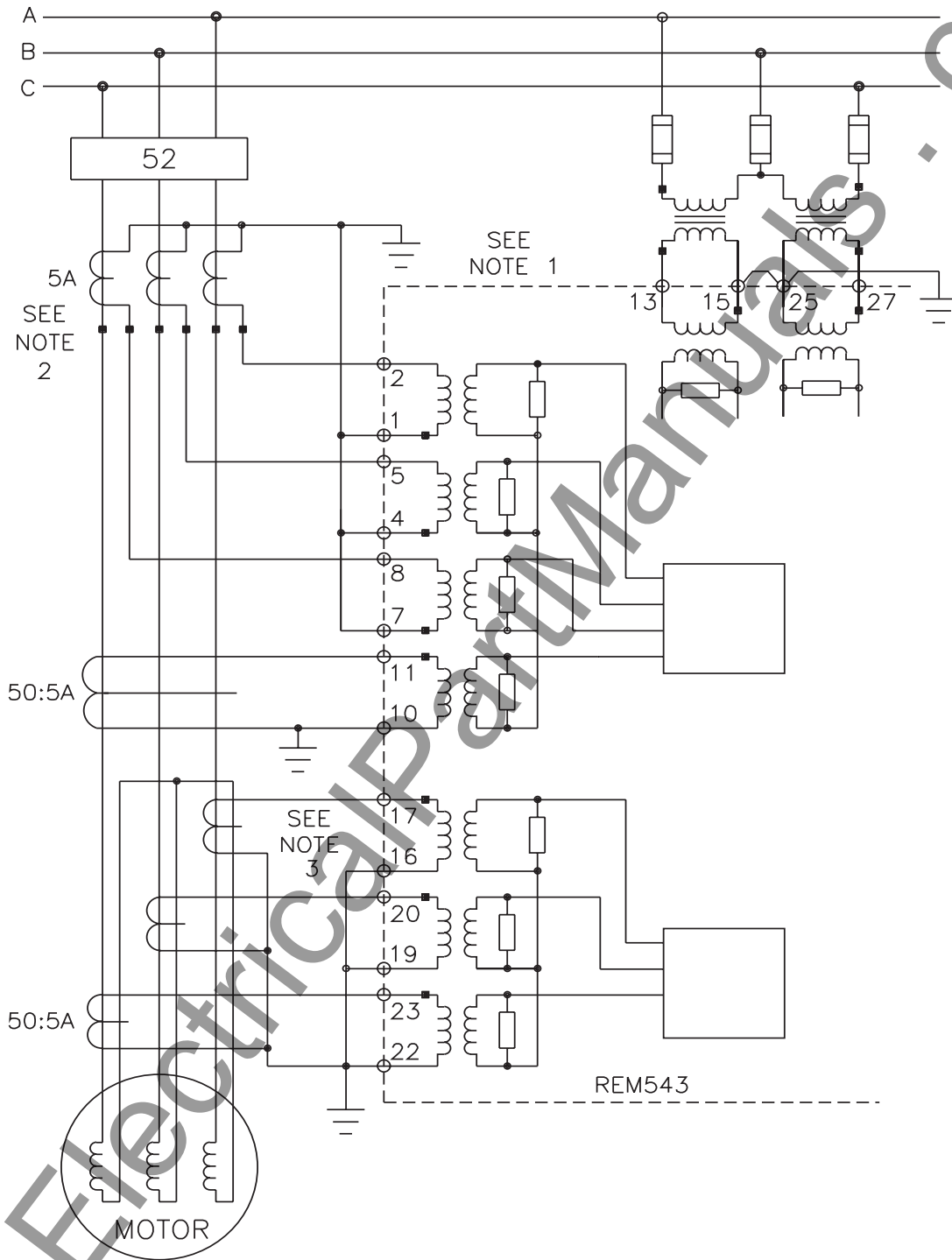

Note 1: All connections shown in this figure are to terminal block "X 1.1" on the REM 543.

Note 2: CT connections shown are for 5A secondary CT's. All REM 543 units also have provision for 1A rated CT's - refer to the instruction book for the connection points.

Note 3: If the CT's for differential protection are not available, the corresponding input terminals on the REM 543 may be left open, and the differential function (device 87) disabled in the settings.

Figure 2: Typical Instrument Transformer Connections to the REM 543 Motor Relay

604788

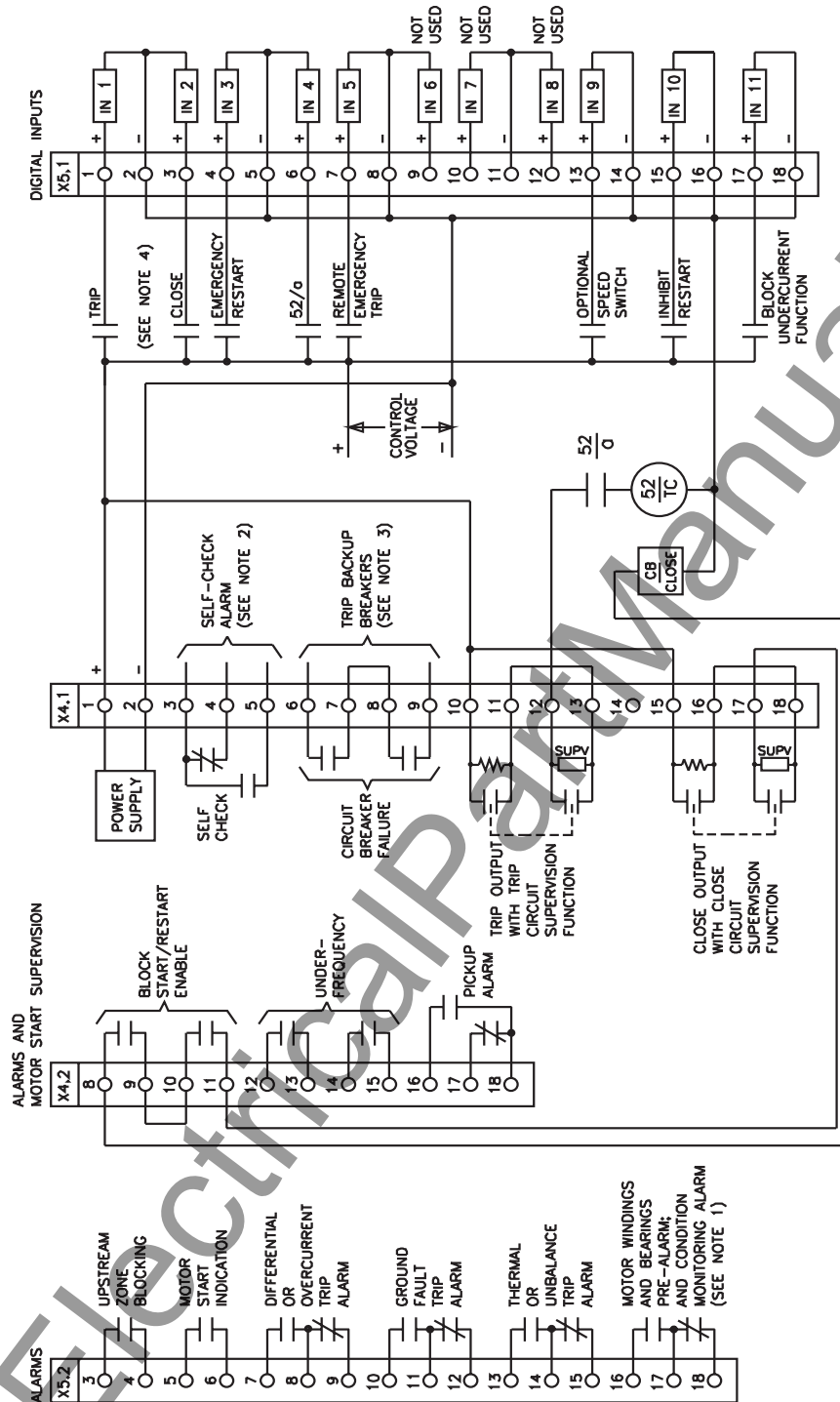

604787-sh1

- Note 1:** Alarm contacts are shown in the normal “non-alarm” state.
- Note 2:** Self-check alarm contacts are shown in the “relay failed” state.
- Note 3:** Use of the circuit-breaker failure function is optional.
- Note 4:** The REM 543 provides for manual trip and close operation of the circuit breaker from the front panel of the relay; therefore the use of physical external contacts as shown here is optional.

Figure 3: Typical Control Circuit Connections for the REM 543 Motor Relay

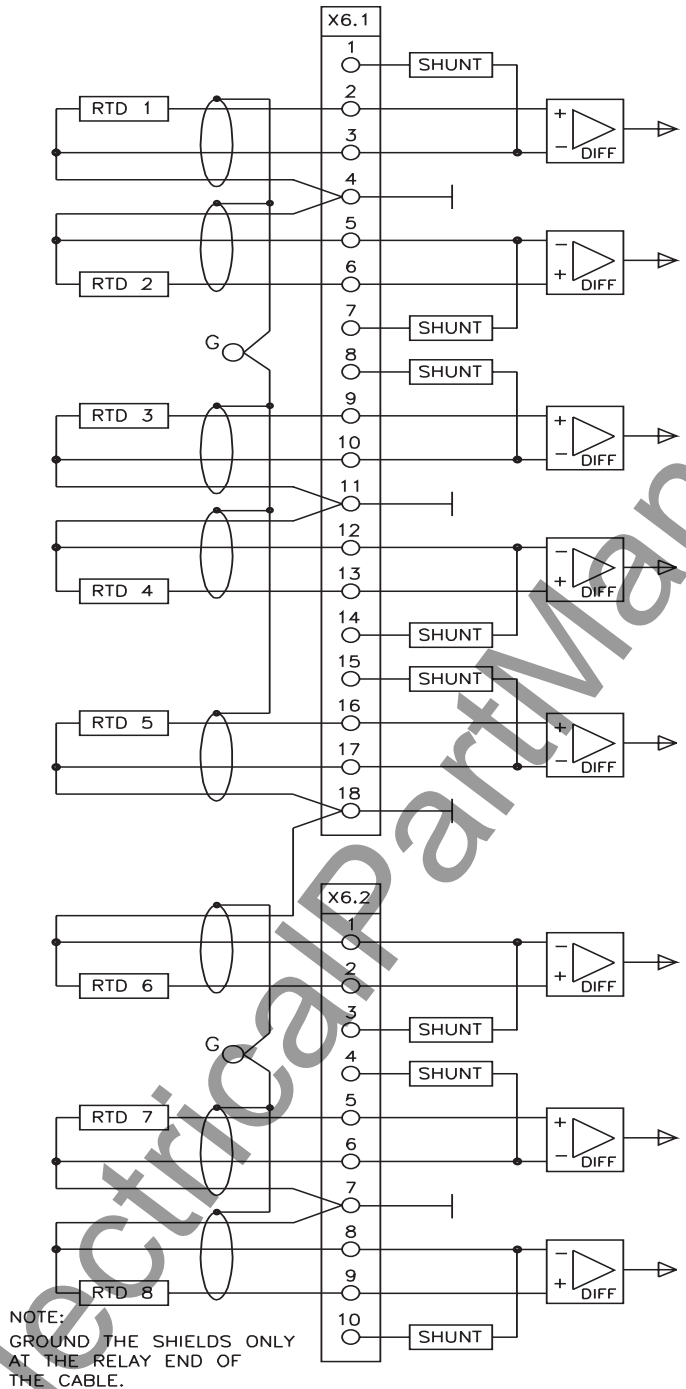

604787-sh2

Note 1: For catalog numbers of the form 272M0X02, RTD 1 through RTD 6 are assigned to Stator Windings and RTD 7 - RTD 8 to the Motor Bearings.

Note 2: For catalog numbers of the form 272M0X01, RTD 1 through RTD 3 are assigned to Stator Windings, RTD 4 through RTD 5 to the Motor Bearings, RTD 6 and RTD 7 to the Load Bearings, and RTD 8 to Ambient.

Figure 4: Shielded Cable RTD Connections to the REM 543 Motor Relay

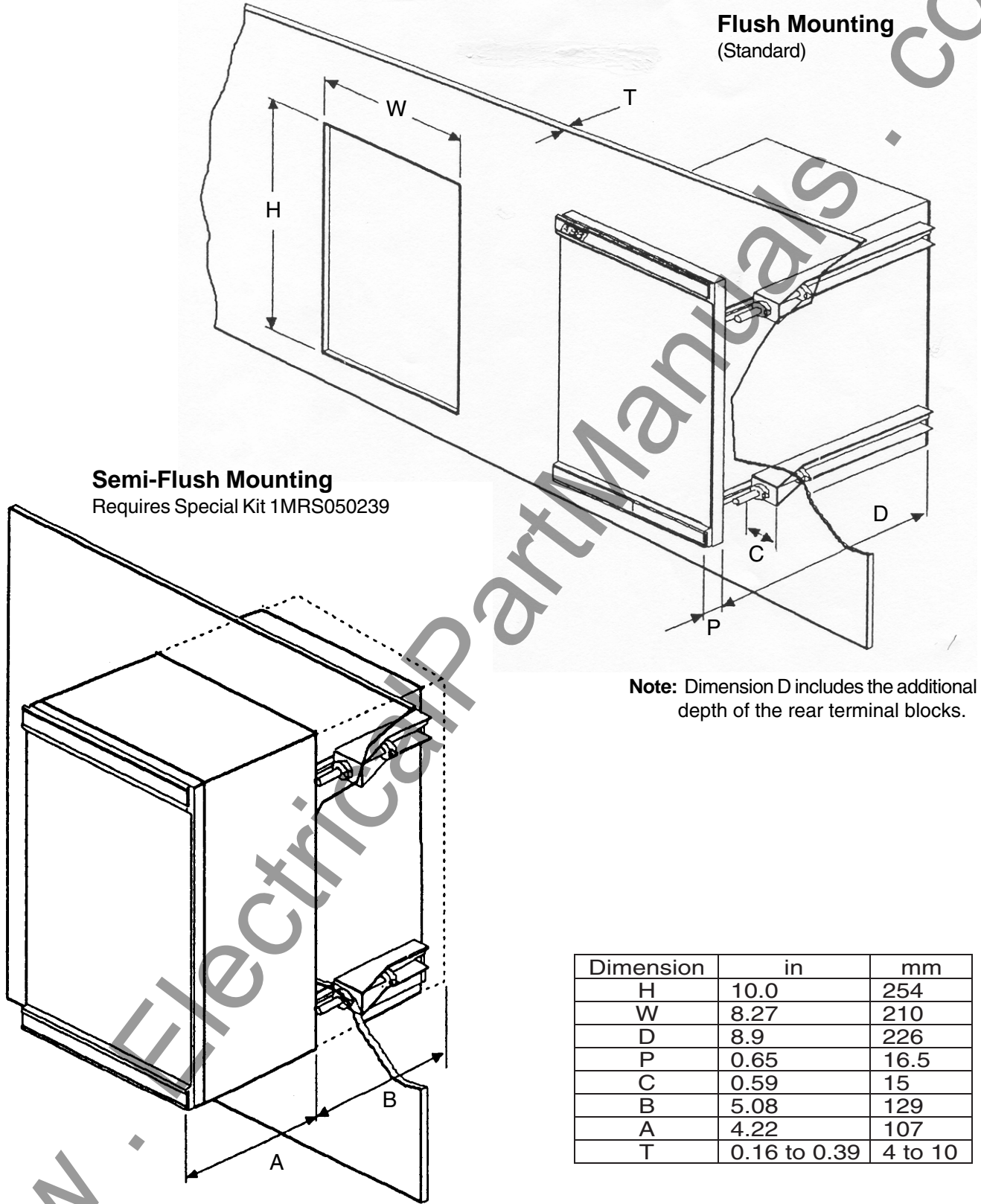

Figure 5: Panel Cutout and Relay Dimensions

Function Block Characteristics and Specifications

Device 27: Three-phase Undervoltage Protection, Function Block UV3Low, 3U<	
Operate voltage	0.10...1.20 x Un
Operate time	0.1...300.0 s
Time multiplier	0.1...1.0
Operation mode	Not in use Definite time C curve (inverse)
Measuring mode	Phase-to-phase voltages; peak-to-peak measurement Phase-to-phase voltages; fundamental freq. measurement
Operation hysteresis	1.0...5.0%
Operation accuracy	Note: The values below apply when $f/f_n = 0.95...1.05$ $\pm 2.5\%$ of set value or $\pm 0.01 \times U_n$
Start time	Injected voltages $< 0.5 \times$ operate voltage: internal time < 32 ms total time < 40 ms
Tripping Output Reset time	40...1000 ms (depends on the minimum pulse width set for the trip output)
Reset ratio	1.04 (range 1.005...1.05)
Reset time (prior to tripping)	< 60 ms
Operate time accuracy at Def Time mode	$\pm 2.5\%$ of set value
Accuracy class index E for inverse time mode	typically: ± 35 ms

Device 37: Undercurrent/Loss of Load Protection, Function Block NUC3St1, 3I<	
Operation mode	Not in use Alarm Trip
Operation criteria	1,2 or 3 phases all 3 phases
Operate current	0.10...0.99 x In
Operate time	0.1...600.0 s
Internal undercurrent blocking	Disabled Enabled
Blocking time from motor start-up	0...7200 s
Measuring mode	Peak-to-peak Fundamental frequency
Operation accuracy	Note: The values below apply when $f/f_n = 0.95...1.05$ $\pm 2.5\%$ of set value or $\pm 0.01 \times I_n$
Start time	Injected currents = $0.5 \times$ start current: internal time < 92 ms total time < 100 ms
Tripping Output Reset time	40...1000 ms (depends on the minimum pulse width set for the trip output)
Reset ratio, typically	1.02
Reset time (prior to tripping)	< 80 ms
Operate time accuracy for Definite Time mode	$\pm 2\%$ of set value or ± 25 ms

Function Block Characteristics and Specifications (continued)

Device 46: Current Unbalance Protection (Negative Phase-sequence Overcurrent), Function Block NPS3Low, I₂>	
Operation mode	Not in use Definite time Inverse time
Pickup value of negative-sequence current I ₂	0.01...0.50 x I _n
Operate time	0.1...120.0 s
Operating characteristic constant K (corresponds to the machine constant, equal to the I ₂ constant of the machine as stated by machine manufacturer)	5.0...100.0
Definite start time at inverse-time mode	0.1...60.0 s
Definite minimum operate time	0.1...120.0 s
Maximum operate time	500...10000 s
Cooling time of the machine	5...10000 s
Number of phases to be measured	2 or 3
Phase Rotation direction	Forward (a-b-c) Reverse (a-c-b)
Drop-off time of the operate time counter	0...1000 ms
Operation accuracy	Note: The values below apply when f/fn = 0.95...1.05 ±2.5% of set value or ±0.01 x I _n
Start time	Injected negative-seq. current = 2.00 x start value: internal time < 32 ms total time < 40 ms
Tripping Output Reset time	70...1030 ms (depends on the minimum pulse width set for the trip output)
Reset ratio, typically	0.96
Reset time (prior to tripping)	< 45 ms
Operate time accuracy for Definite Time mode	±2% of set value or ±20 ms
Accuracy class index E for inverse mode	typically ±2% of the calculated ideal operate time or ±20 ms

Device 47: Phase-sequence Voltage Protection, Function Block PSV3St1 U_{1<}, U_{2>}, U_{1>}	
Start value U _{2>}	0.01...1.00 x U _n
Start value U _{1<}	0.01...1.20 x U _n
Start value U _{1>}	0.80...1.60 x U _n
Operate time U _{2>}	0.04...60.00 s
Operate time U _{1<}	0.04...60.00 s
Operate time U _{1>}	0.04...60.00 s
Operation mode	Not in use; U _{1<} & U _{2>} & U _{1>} ; U _{1<} & U _{2>} ; U _{2>} & U _{1>} ; U _{1<} & U _{1>} ; U _{2>} ; U _{1<} ; U _{1>}
Dir. selection	Forward; Reverse; Input ROT DIR
Operation accuracy	Note! The values below apply when f/fn = 0.95...1.05 ± 2.5% of set value or ± 0.01 x U _n
Trip time	U _{2>} operation: Injected negative-seq. voltage = 1.1 x start value: internal time < 42 ms total time < 50 ms U _{1<} operation: Injected positive-seq. voltage = 0.50 x start value: internal time < 32 ms total time < 40 ms U _{1>} operation: Injected positive-seq. voltage = 1.1 x start value: internal time < 42 ms total time < 50 ms
Output Contact Reset time	70...1030 ms (depends on the minimum pulse width set for the TRIP output)
Reset ratio, typically	U _{2>} operation: 0.96 U _{1<} operation: 1.04 U _{1>} operation: 0.99
Reset time (prior to tripping)	< 45 ms (for all operations)
Operate time accuracy	± 2% of set value or ± 20 ms

Device 49: Three-phase Thermal Overload Protection, Function Block TOL3Dev	
BASIC SETTINGS	
Starting current of the motor	0.10...10.00 x In
Max. starting time permitted for the motor	0.1...120.0 s
Number of starts allowed from cold state	1...3
Type of device to be protected	Motor; through-ventilated, rated power < 1500 kW Motor; through-ventilated, rated power > 1500 kW Motor; surface cooling, rated power < 500 kW Motor; surface cooling, rated power > 500 kW
Trip temperature	80.0...120.0%
Prior alarm temperature	40.0...100.0%
Restart inhibit (temperature limit for successful restarting)	40.0...100.0%
Ambient temperature	-50.0...100.0 C
Cooling time-constant	1.0...10.0 x time constant
ADVANCED SETTINGS	advanced settings are calculated and installed by the relay after the user selects the basic settings; modifications can be made by the user.
Short time-constant for stator	0.0...999.0 min
Long time-constant for stator	0.0...999.0 min
Weighting factor of the short time-constant for stator	0.00...1.00
Temperature rise of stator at rated current	0.0...350.0 C
Maximum temperature of stator	0.0...350.0 C
Short time-constant for rotor	0.0...999.0 min
Long time-constant for rotor	0.0...999.0 min
Weighting factor of the short time-constant for rotor	0.00...1.00
Temperature rise of rotor at rated current	0.0...350.0 C
Maximum temperature of rotor	0.0...350.0 C
Operation mode (principle of ambient temperature compensation)	Not in use No sensors; the set ambient temperature. 1 RTD sensor used.
Waiting time for a successful restart (Read-only parameter)	0...86400 s
Predicted time to the trip (Read-only parameter)	0...86400 s
Operation accuracy	Note! The values below apply when f/fn = 0.95...1.05 ±1.0%, I = 0.1...10.0 x In
Reset ratio	Trip: (Calculated temp. rise - 0.1) / Trip temperature Start: (Calculated temp. rise - 0.1) / Prior alarm temperature Restart: (Calculated temp. rise - 0.1) / Restart inhibit temperature limit

Device 50: Phase Fault Protection, Instantaneous, Function Block NOC3Inst, 3I>>>	
Pickup current	0.10...40.00 x In
Operate time	0.05...300.00 s
Operation mode	Not in use Definite time Instantaneous
Measuring mode	Peak-to-peak Fundamental frequency
Drop-off time of the operate time counter	0...1000 ms
Operation accuracy	Note: The values below apply when f/fn = 0.95...1.05 0.1...10 x In: ±2.5% of set value or ±0.01 x In 10...40 x In: ±5.0% of set value
Start time	Injected currents > 2.0 x start current: internal time < 32 ms total time < 40 ms
Output Contact Reset time	40...1000 ms (depends on the minimum pulse width set for the trip output)
Reset ratio, typically	0.95
Reset time (prior to tripping)	< 45 ms
Operate time accuracy for Definite Time mode	±2% of set value or ±20 ms

Function Block Characteristics and Specifications (continued)

Device 50N or 50GS Ground-fault Protection, Function Block NEF1Low, $I_b >$	
Pickup current	1.0...100.0% of I_n
Operate time for Definite Time mode	0.05...300.00 s
Time multiplier for inverse time curves	0.05...1.00
Operation mode	Not in use Definite time Extremely inverse Very inverse Normal inverse Long time inverse RI-type inverse RD-type inverse
Measuring mode	Peak-to-peak Fundamental frequency
Drop-off time of the operate time counter	0...1000 ms
Operation accuracy	Note: The values below apply when $f/f_n = 0.95...1.05$
Start time	$\pm 2.5\%$ of set value + $0.0005 \times I_n$ Injected currents $> 2.0 \times$ start current: internal time < 32 ms total time < 40 ms
Output Contact Reset time	40...1000 ms (depends on the minimum pulse width set for the trip output)
Reset ratio, typically	0.95
Reset time (prior to tripping)	< 45 ms
Operate time accuracy for Definite Time mode	$\pm 2\%$ of set value or ± 20 ms
Accuracy class index E for inverse time modes	Class index E = 5.0 or ± 20 ms

Device 51/66: Motor Starting and Locked Rotor Protection, Function Block, MotStart, $I_s^2 t, n <$	
Start current (for motor)	1.0...10.0 x I_n
Start time (for motor)	0.3...250.0 s
Time-based restart inhibit limit	1.0...500.0 s
Countdown rate of the time counter	2.0...250.0 s/h
Stalling time permitted for rotor	2.0...120.0 s
Operation mode	Not in use $I^2 t$ $I^2 t$ & Stall
Start counter (Read-only parameter)	0...99999
Time to restart enable (Read-only parameter)	0...99999 min
Stall input (Speed switch signal for motor stalling indication; read-only parameter)	Not active/ not available Active
Operation accuracy	for $f/f_n = 0.95...1.05$: $\pm 2.5\%$ of set value or $\pm 0.01 \times I_n$
Start time	for $f/f_n = 0.95...1.50$: internal time < 22 ms total time < 30 ms for $f/f_n = 0.50...0.95$: internal time < 32 ms total time < 40 ms
Reset ratio, typically	0.95
Reset time (prior to tripping)	< 50 ms

Device 55: Power Factor Protection for Synchronous Motors, Function Block OPOW6St1, P >>/Q >>	
Operate time	0.04...300.00 s
Angle (power direction)	-90...90
Power setting (start power)	1.0...200.0 % Sn
Drop-off time	0.00...60.00 s
Measuring mode	Not in use (See Note 55-1) U1,U2,U3 & I1,I2,I3 U12,U23,U0 & I1,I2,I3 U23,U31,U0 & I1,I2,I3 U12,U31,U0 & I1,I2,I3 U12,U23 & I1,I2,I3 U23,U31 & I1,I2,I3 U12,U31 & I1,I2,I3 U1 & I1 U2 & I2 U3 & I3 U12 & I3 U23 & I1 U31 & I2
Power direction	Forward Reverse
Operation accuracy	Note! The values below apply when f/fn = 0.95...1.05 ±1.0% of set value or ±0.01 x rated value
Start time	Injected power > 2.0 x power setting: internal time < 32 ms total time < 40 ms
Reset time (after tripping)	70...1030 ms (depends on the minimum pulse width set for the trip output)
Reset ratio, typically	0.98
Reset time (prior to tripping)	< 45 ms
Operate time accuracy for Def Time mode	±2% of set value or ±20 ms

Device 59: Three-phase Overvoltage Protection, Function Block OV3Low, 3U>	
Pickup voltage	0.10...1.60 x Un
Operate time	0.05...300.0 s
Time multiplier	0.05...1.00
Operation mode	Not in use Definite time A curve B curve
Measuring mode	Phase-to-phase voltages; peak-to-peak measurement Phase-to-phase voltages; fundamental freq. measurement
Operation hysteresis	1.0...5.0%
Operation accuracy	Note: The values below apply when f/fn = 0.95...1.05 ±2.5% of set value
Start time	Injected voltages = 1.1 x start voltage: internal time < 42 ms total time < 50 ms
Output Contact Reset time	40...1000 ms (depends on the minimum pulse width set for the trip output)
Reset ratio	0.96 (range 0.95...0.99)
Reset time (prior to tripping)	< 50 ms
Operate time accuracy at DefiniteTime mode	±2% of set value or ±20 ms
Accuracy class index E for Inverse mode	typically ±20 ms

Note 55-1: For Loss-of-Excitation protection of synchronous motors, the mode setting [U12, U23 & I1, I2, I3] and power direction setting [Forward] would be selected for relays configured per this bulletin.

Function Block Characteristics and Specifications (continued)

Device 81: Underfrequency or Overfrequency protection, 2 stages, Function Blocks Freq1St1, Freq1St2, f</f>, df/dt	
Operation mode	Not in use f</f> 1 timer f</f> 2 timers f</f> OR df/dt< f</f> AND df/dt< f</f> OR df/dt< f</f> AND df/dt<
Undervoltage limit for blocking	0.30...0.90 x Un
Start value for under-/overfrequency prot.	25.00...75.00 Hz
Operate time for under-/overfrequency prot.	0.10...120.00 s
Start value for df/dt protection	0.2...10.0 Hz/s
Operate time for df/dt protection	0.12...120.00 s
Operation accuracy	Under-/overfrequency (f</f>): ±10 mHz Frequency rate of change (df/dt); real df/dt < ±5 Hz/s: ±100 mHz/s real df/dt < ±15 Hz/s: ±2.0% of real df/dt Undervoltage blocking: ±1.0% of set value
Start time	Total start times at fn = 50 Hz: Frequency measurement < 100 ms Df/dt measurement < 120 ms
Output Contact Reset time	140...1000 ms (depends on the minimum pulse width set for the trip output)
Operate time accuracy	±2% of set value or ±30 ms

Device 87: Flux-balance based differential protection, Function Block Diff3, 3ΔI>	
Basic setting	0.5...50%
Operation accuracy	Note: The values below apply when f/in = 0.95...1.05 ± 2.5% of set value or ± 0.004 x In
Trip time	Injected currents > 2.0 x start current: internal time < 20 ms total time < 30 ms
Output Contact Reset time	60...1020 ms (depends on the minimum pulse width set for the TRIP output)
Reset ratio, typically	0.95
Reset time (prior to tripping)	This high speed function block will always trip once the current exceeds the operate value.

Condition Monitoring Function Blocks

Functions	Description
CMBWEAR1	Circuit-breaker electric wear 1
CMCU3	Supervision function of the energizing current input circuit
CMSCHED	Scheduled maintenance
CMTCS1	Trip circuit supervision 1
CMTCS2	Trip circuit supervision 2
CMTIME1	Operate time counter 1 for the operate time used (e.g. motors)
CMVO3	Supervision function of the energizing voltage input circuit
FuseFail	Fuse Failure Detection

Control Function Blocks

Functions	Description
COCB1	Circuit breaker 1 control with indication
COIND1...COIND2	Switching device 1 + 2 indication
COSW1	On/off switch
MMIALAR1...MMIALAR8	Alarm channel 1...8, LED indication
MMIDATA1...MMIDATA5	MIMIC data monitoring point 1...5

Measurement Function Blocks

Ground current measurement, Function Block MECU1A	
Io (A)	0.0...20000.0 A
Io (%)	0.0...80.0% In

Three-phase current measurement, Function Block MECU3A	
IL1	0.0...20000.0 A
IL2	0.0...20000.0 A
IL3	0.0...20000.0 A
IL1	0.0...1000.0% In
IL2	0.0...1000.0% In
IL3	0.0...1000.0% In
IL1 demand	0.0...20000.0 A
IL2 demand	0.0...20000.0 A
IL3 demand	0.0...20000.0 A
IL1 demand	0.0...1000.0% In
IL2 demand	0.0...1000.0% In
IL3 demand	0.0...1000.0% In

Transient disturbance recorder for 16 analog channels, Function Block MEDREC16	
The transient disturbance recorder MEDREC16 is used for recording the current and voltage waveforms, as well as the status data of internal IEC 61131-3 based logic signals and digital inputs connected to the relay terminals. The maximum number of analog inputs and logic signals is 16. One fundamental cycle contains 40 samples.	
Operation mode	Saturation Overwrite Extension
Pre-trigger time	0...100%
Over limit ILx	0.00...40.00 x In
Over limit Io	0.00...40.00 x In
Over limit Iob	0.00...40.00 x In
Over limit Uo	0.00...2.00 x Un
Over limit Ux	0.00...2.00 x Un
Over limit Uxy	0.00...2.00 x Un
Over limit U12b	0.00...2.00 x Un
Over limit ILxb	0.00...40.00 x In
Under limit Ux	0.00...2.00 x Un
Under limit Uxy	0.00...2.00 x Un
AI filter time	0.000...60.000 s

The recording can be triggered by any (or several) of the alternatives listed below:

- triggering on the rising or falling edge of any (or several) of the digital inputs
- triggering on overcurrent, overvoltage or undervoltage
- manual triggering via the menu or with the push-button F on the front panel (if configured)
- triggering via serial communication or a parameter
- periodic triggering

The recording length depends on the number of recordings and inputs used. For example, the following combination of recording length, number of recordings and number of inputs is available at 50 Hz:

# recordings \ # channels	1	3	10
1	1066 cyc. 21.3 s	399 cyc. 7.9 s	125 cyc. 2.5 s
5	212 cyc. 4.2 s	79 cyc. 1.5 s	25 cyc. 0.5 s
10	106 cyc. 2.1 s	39 cyc. 0.7 s	12 cyc. 0.24 s

System frequency measurement, Function Block MEFR1	
Frequency	10.00...75.00 Hz
Average Freq.	10.00...75.00 Hz
Voltage U	0.0...2.0 x Un

Function Block Characteristics and Specifications (continued)

Three-phase power and energy measurement, Function Block MEPE7	
P3 (kW)	-999999...999999 kW
Q3 (kvar)	-999999...999999 kvar
Power factor DPF	-1.00...1.00
Power factor PF	-1.00...1.00
P3 demand (kW)	-999999...999999 kW
Q3 demand (kvar)	-999999...999999 kvar
Energy kWh	0...999999999 kWh
Reverse kWh	0...999999999 kWh
Energy kvarh	0...999999999 kvarh
Reverse kvarh	0...999999999 kvarh

Three-phase voltage measurement, Function Block MEVO3A	
UL1_U12	0.00...999.99 kV
UL2_U23	0.00...999.99 kV
UL3_U31	0.00...999.99 kV
UL1_U12	0.00...2.00 x Un
UL2_U23	0.00...2.00 x Un
UL3_U31	0.00...2.00 x Un
UL1_U12 average	0.00...999.99 kV
UL2_U23 average	0.00...999.99 kV
UL3_U31 average	0.00...999.99 kV
UL1_U12 average	0.00...2.00 x Un
UL2_U23 average	0.00...2.00 x Un
UL3_U31 average	0.00...2.00 x Un

The following function blocks are included in the hardware package, but are not used in the pre-configured units shown in this bulletin. They could be considered for activation for special applications-contact the factory.

Function Block	Device Number	Description
UI6 Low	21	Three-phase Underimpedance, Low set stage
UI6 High	21	Three-phase Underimpedance, High set stage
UE6 Low	40	Three-phase Underimpedance, Low set stage
UE6 High	40	Three-phase Underimpedance, High set stage
Fuse Fail	60	PT Fuse Failure detection
MEA01...04	-	Analog Outputs (only with RTD models)
CBCM	-	Various circuit breaker condition monitoring functions

Hardware Ratings and Specifications

Rating - Measuring inputs

Rated frequency	50.0/60.0 Hz		
Current inputs	rated current	1 A/5 A	
	Thermal withstand capability	continuously	4 A/20 A
		for 1 s	100 A/500 A
	dynamic current withstand, half-wave value	250 A/1250 A	
Voltage inputs	input impedance	<100 mW/<20 mW	
	rated voltage	100 V/110 V/115 V/120 V (parameterization)	
	voltage withstand, continuously burden at rated voltage	2 x U _n (240 V) <0.5 VA	

Control Power Input

Type	PS1 / 240V style	External display module	PS1 / 48V style
Input voltage, ac	110/120/220/240 V		-
Input voltage, dc	110/125/220 V		24/48/60V
Operating range	ac 85...110%, dc 80...120% of rated value		dc 80...120% of rated value
Power Consumption	<50 W		
Allowable Ripple in dc auxiliary voltage	max. 12% of the dc value		
Interruption time in auxiliary dc voltage without resetting	<50 ms, 110 V and <100 ms, 200 V		
Internal overtemperature indication	+78 C (+75...+83 C)		

Digital Inputs

Power supply version	PS1 / 240 V style	PS1 / 48 V style
Input voltage, dc	110/125/220 V	24/48/60/110/125/220 V
Operating range, dc	80...265 V	18...265 V
Current drain	~2...25 mA	
Power consumption/input	<0.8 W	
Pulse counting (specific digital inputs), frequency range	0...100 Hz	

RTD Inputs

Supported RTD sensors	100 Ω Platinum	TCR 0.00385 (DIN 43760)
	250 Ω Platinum	TCR 0.00385
	1000 Ω Platinum	TCR 0.00385
	100 Ω Nickel	TCR 0.00618 (DIN 43760)
	120 Ω Nickel	TCR 0.00618
	250 Ω Nickel	TCR 0.00618
	1000 Ω Nickel	TCR 0.00618
	10 Ω Copper	TCR 0.00427
Max lead resistance (three-wire measurement)	200 Ω per lead	
Accuracy	±0.5% of full scale ±1.0% of full scale for 10 Ω Copper RTD	
Isolation	2 kV (inputs to outputs and inputs to protective earth)	
Sampling frequency	5 Hz	
Response time	Filter time + 30 ms (430 ms...5.03 s)	
RTD/ Resistance sensing current	max 4.2 mA RMS 6.2 mA RMS for 10 Ω Copper	
Current input impedance	274 ohms ±0.1%	

Hardware Ratings and Specifications (continued)

Ratings - Alarm Contacts

Max system voltage	250 V ac/dc
Continuous carry	5 A
Make and carry for 0.5 s	10 A
Make and carry for 3 s	8 A
Breaking capacity when control circuit time-constant L/R <40 ms, at 48/110/220 V dc	1 A/0.25 A/0.15 A

Ratings - Tripping Contacts

Max system voltage	250 V ac/dc	
Continuous carry	5 A	
Make and carry for 0.5 s	30 A	
Make and carry for 3 s	15 A	
Breaking capacity when control circuit time-constant L/R <40 ms, at 48/110/220 V dc	5 A/3 A/1 A	
Minimum contact load	100 mA, 24 V ac/dc (2.4 VA)	
TCS (Trip Circuit Supervision)	Control voltage range	20...265 V ac/dc
	Current drain through the supervision circuit	approx. 1.5 mA (0.99...1.72 mA)
	Minimum voltage (threshold) over a contact	20 V ac/dc (15...20 V)

Environmental Conditions

Specified service temperature range	-10...+55 C	
Transport and storage temperature range	-40...+70 C	
Degree of protection by enclosure	Front side, flush-mounted	IP 54
	Rear side, connection terminals	IP 20
Dry heat test	according to IEC 60068-2-2 (BS 2011: Part 2.1 B)	
Dry cold test	according to IEC 60068-2-1	
Damp heat test cyclic	according to IEC 60068-2-30 r.h. = 95%, T = 25 ...55 C	
Storage temperature tests	according to IEC 60068-2-48	

Standard Tests

Insulation tests	Dielectric test IEC 60255-5, ANSI C37.90	Test voltage	2 kV, 50 Hz, 1 min.
	Impulse voltage test IEC 60255-5	Test voltage	5 kV, unipolar impulses, waveform 1.2/50 μs, source energy 0.5 J
	Insulation resistance measurements IEC 60255-5	Insulation resistance	> 100 MΩ, 500 V dc
Mechanical tests	Vibration tests (sinusoidal)		IEC 60255-21-1, class I
	Shock and bump test		IEC 60255-21-2, class I

Note: Dielectric tests are part of routine production tests. All other tests shown are Type Tests.

Electromagnetic Compatibility Tests

The EMC immunity test level fulfills the requirements listed below		
1 MHz burst disturbance test, class III (IEC 60255-22-1; ANSI C37.90.1-2001)	common mode	2.5 kV
	differential mode	1.0 kV/2.5 kV
Electrostatic discharge test, class III (IEC 61000-4-2 and 60255-22- 2)	for contact discharge	6 kV
	for air discharge	8 kV
Radio frequency interference test	conducted, common mode (IEC 61000-4-6)	10 V (rms), f = 150 kHz...80 MHz
	radiated, amplitude-modulated (IEC 61000-4-3)	10 V/m (rms), f = 80...1000 MHz
	radiated, pulse-modulated (ENV 50204)	10 V/m, f = 900 MHz
	radiated, test with a portable transmitter (IEC 60255-22-3, method C)	f = 77.2 MHz, P = 6 W; f = 172.25 MHz, P = 5 W
Fast transient disturbance test (IEC 60255-22-4 and IEC 61000-4-4; ANSI C37.90.1-2001)	power supply	4 kV
	I/O ports	2 kV
Surge immunity test (IEC 61000-4-5)	power supply	4 kV, common mode 2 kV, differential mode
	I/O ports	2 kV, common mode 1 kV, differential mode
Power frequency (50 Hz) magnetic field (IEC 61000-4-8)	100 A/m	
Voltage dips and short interruptions (IEC 61000-4-11)	30%, 10 ms	
	> 90%, 5000 ms	
Electromagnetic emission tests (EN 55011 and EN 50081-2)	conducted RF emission (mains terminal)	EN 55011, class A
	radiated RF emission	EN 55011, class A
CE approval	Complies with the EMC directive 89/336/EEC and the LV directive 73/23/EEC.	
UL Recognition	Pending - Contact ABB for present status of the UL review process.	

General

Toolboxes	CAP 501 (settings, event records, metering data) CAP 505 (engineering and special configuration)
Event recording	all events are recorded in higher level syntax: reason, time, date; the last 100 events are recorded
Data recording	records the operate values
Protection functions Control functions Condition monitoring functions Measurement functions	see Technical Descriptions of Functions, CD-ROM (1MRS 750889-MCD)
Self-supervision	RAM circuits ROM circuits Parameter memory circuits CPU watchdog Power supply Digital I/O modules MMI module RTD/analog input module Internal communication bus A/D converters and analog multiplexers
Mechanical dimensions	See Figure 5. Also refer to the Installation Manual (1MRS750526-MUM)

Summary of the Functionality of the ABB REM 543 Motor Protection Relay

Characteristic	ABB REM 543
Multifunction Motor Protection	Yes
Protection Elements	
Undervoltage protection 27	Yes
Undercurrent/load loss 37	Yes
Bearing Overtemperature (RTD) 38	Yes (see note 1)
Negative Sequence overcurrent 46	Yes
Phase Sequence (voltage) 47	Yes
Thermal Overload 49	Yes
Exponential cooldown/block start	Yes
Overtemperature (RTD) 49T	Yes (see note 1)
Phase Short circuit protection 50	Yes
Ground Fault protection 50N/ 50GS	Yes
Locked Rotor protection 51	Yes
with Starts per Hour limit 66	Yes
mechanical jam/stall	No
Overvoltage protection 59	Yes
Under/Over Frequency 81	Yes
Flux balance differential 87	Yes
For synchronous motors:	
Loss of Field/Out of Step 55	Yes
Breaker Failure	
62BF	Yes
Control Elements	
Accepts speed switch input	Yes
Block Start Output Contact	Yes
Emergency Restart Contact Input	Yes
Trip / Close control from front panel with select before operate sequence	Yes
Motor Feeder Monitoring	
MMI	Large graphical LCD screen, 19 rows
LED status and operation indicators	Many to signal various functions
Metering +/- 0.5% current and voltage +/- 1.0% watts and vars.	Current, Voltage, Watts, Vars, VA, PF, Hz, W-Hr Var-Hr.

Summary of the Functionality of the ABB REM 543 Motor Protection Relay

Characteristic	ABB REM 543
Communications	
PC communication (front port)	Yes - optical RS232
Modbus Communications Protocol (rear port)	Yes - RS232
Condition Monitoring	
Trip Coil Supervision	Yes
Circuit Breaker condition monitoring & status indication	Yes
Condition monitoring for loss of vt or ct input signals	Yes
Self Diagnostics Alarm Output Contact	Yes
PT Fuse Failure Detection	Yes
Ratings	
CT inputs	Dual rated: 1A and 5A
PT inputs	100/110/115/120Vac
Control Voltage	110/120/220/240Vac, 110/125/220/250Vdc; or 24-60 Vdc
Control Power Consumption	40W maximum
Service temperature	-20 to +60 degrees C
Standards and Construction	
Protective Relay Standards	IEC 255, ANSI C37.90
UL recognition	In Progress
ISO 9001	Yes
Flush or Semi-Flush mounting case	Yes
Panel Cutout Dimensions	10.0 h x 8.3 w inches
Overall Depth Behind Panel	9.0 inches
Drawout Construction	No
Rear Terminals	Phoenix type
Protective Function Libraries	Pre-Configured models, but possibility of additional functionality in REM543 library. For example, 21 element for high inertia motors.
Digital Contact Inputs	(8 of 11) preconfigured
High Capacity Output Contacts	(5) preconfigured
Lower Capacity Alarm Contacts	(8) preconfigured

Note 1: REM543 has (8) total RTD inputs. Standard pre-configurations of the REM543 allow for:

- Configuration A: (3) stator winding RTD's, (2) motor bearing RTD's, (2) load bearing RTD's, and (1) ambient RTD.
- Configuration B: (6) stator winding RTD's and (2) motor bearing RTD's.
- Configuration C: without RTD inputs.

REM 543 Motor Protection Relay

Catalog Numbers - Preconfigured Units

RTD Input Assignments				REM 543	
Motor Windings	Motor Bearings	Load Bearings	Ambient	Control Voltage (1)	Catalog Number
3	2	2	1	24-60 Vdc	272M0301
				110-240 V ac/dc	272M0401
6	2	0	0	24-60 Vdc	272M0302
				110-240 V ac/dc	272M0402
No RTD Inputs				24-60 Vdc	272M0303
				110-240 V ac/dc	272M0403

Note 1: See Page 19 for complete information on control voltage ratings and operating ranges.

Note 2: Contact the factory regarding applications for high-inertia motors, where the normal starting time is nearly equal to or greater than the allowable locked rotor time. Models of the REM 543 with additional functionality can be supplied for these applications.

References

Additional Information

Front Port Communications Tool	CAP-501 (CD-ROM only) 1MRS 751787-MCD
Quick Start Information, Acceptance Tests, and Application Guide for the Pre-Configured Units	TG 7.11.1.7-72
Installation Manual	1MRS 750526-MUM
Operator's Manual	1MRS 750500-MUM
Technical Descriptions of the Function Blocks	1MRS 750889-MCD (CD-ROM only)
Technical Reference Manual	1MRS 750915-MUM
Modbus Protocol Technical Guide	TG 7.11.1.7-73
Motor Thermal Overload Function Block Settings Analysis Software (application tool)	TolDev1_0.xls

Modbus is a registered trademark of Modicon/Group Schneider



ABB Inc.
Substation Automation and Protection Division
7036 Snowdrift Road
Allentown, PA 18106
USA
Tel: (610) 395-7333 Toll Free: 800-634-6005
Fax: (610) 395-1055
E-mail: powerful.ideas@us.abb.com
Website: www.abb.com/substationautomation

ABB Inc.
Substation Automation and Protection Division
4300 Coral Ridge Drive
Coral Springs, FL 33065
USA
Tel: (954) 752-6700 Toll Free: 800-523-2620
Fax: (954) 345-5329