

July, 1992
Supersedes Descriptive Bulletin 41-235S
pages 1-2, dated September, 1990
Mailed to: E, D, C/41-200B

Device Number: 27/59

CIRCUIT SHIELD[®] Type 27/59 Under/Overvoltage Relay

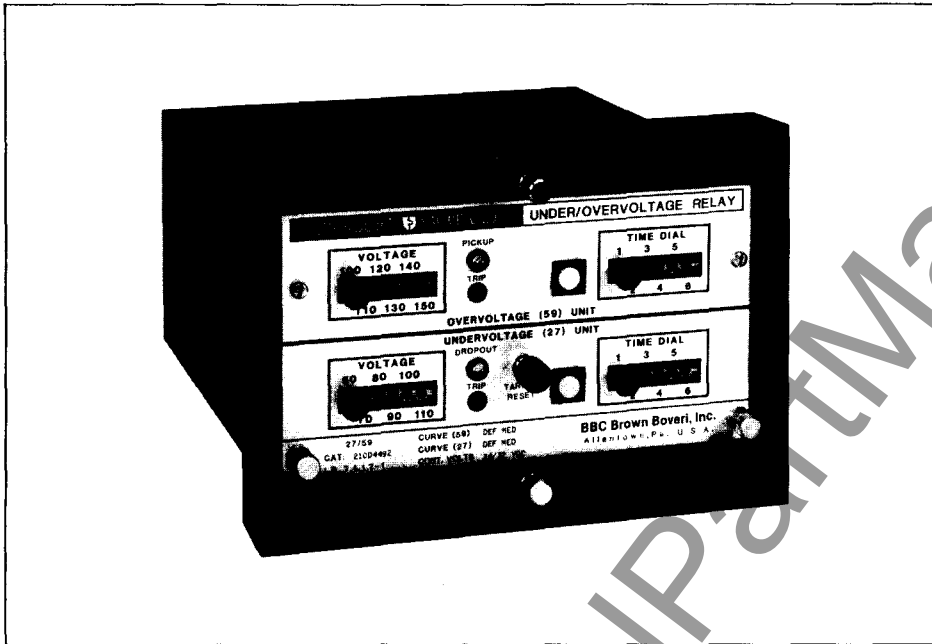

Application

The Type 27/59 under/overvoltage relays are general purpose single phase relays designed to be used wherever protection is required against abnormal voltage conditions. They are generally used for incoming line protection, bus transfer schemes, and motor protection. An important application is in co-generation schemes to create an acceptable voltage window for the generator. A companion under/over frequency relay, the Type 81, can be used to create a frequency window.

Voltage and delay settings for the undervoltage and overvoltage units are totally independent from each other.

The Type 27/59 provides an LED pickup/drop-out indicator for each function to indicate when the relay starts into its timing mode. Both LEDs are self resetting when the voltage returns to normal. A target is provided for each element of the 27/59. The targets will maintain indication on loss of control power.

The Type 27/59 is frequency compensated for reliable operation from 45 to 400 Hz.

Features

- Independent undervoltage and overvoltage adjustments
- Definite time, or high speed
- Accurate, repeatable characteristics
- Low burden
- Seismic capability to 6g ZPA
- Transient immunity
- Drawout construction
- 2 year warranty

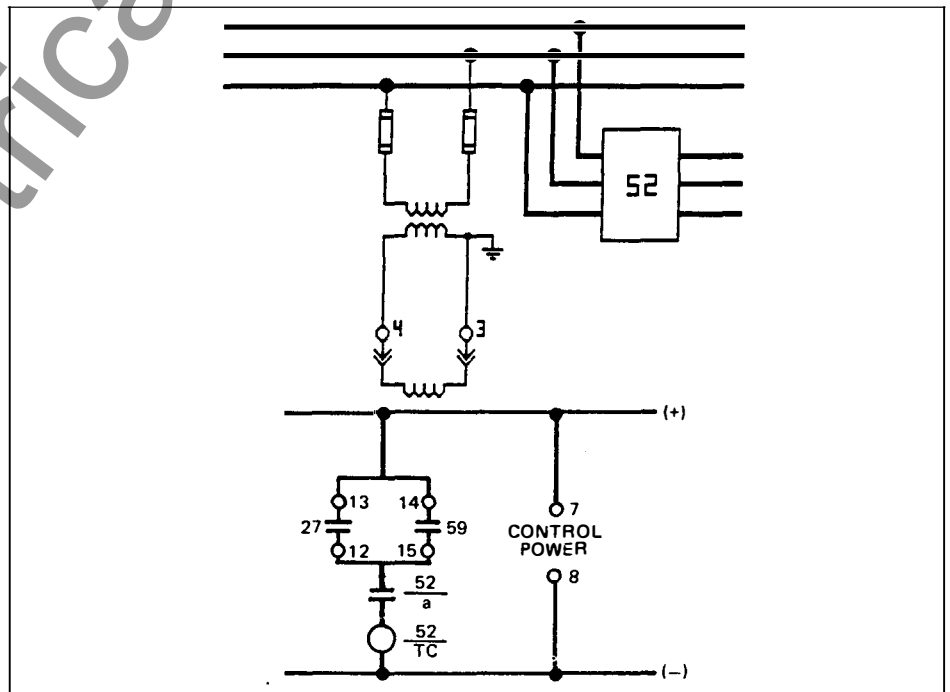

Figure 1 — Typical Connections for the Type 27/59.

Specifications

Dropout Taps:	Undervoltage unit 30, 35, 40, 45, 50, 55 60, 70, 80, 90, 100, 110 Volts
Pickup Taps:	Overtvoltage unit 60, 65, 70, 75, 80, 85 100, 110, 120, 130, 140, 150 Volts
Time Delay:	Per voltage unit. –instantaneous: 0.05 sec. max. delay –definite – short: 0.1-1.0 sec. range –definite – med.: 1.0-10 sec. range
Input Circuit Rating:	160 Vac continuous, 50/60 Hz 300 Vac, 10 seconds
Burden:	0.1 VA, 1.0 P.F. @ 120 Vac
Output Circuit:	(1) N.O. contact per function and (1) Selectable, normally closed or normally open
Series Target Coil Rating:	30 Amp Tripping (1 amp minimum trip circuit current req'd. to set targets) For trip circuit currents below 1 amp, .25 amps minimum, add "-ST" to catalog number for sensitive target coil.
Rating @ 125 Vdc:	30 amps tripping duty 5 amps continuous 1 amp break, resistive 0.3 amps, inductive
Control Power:	48/125 Vdc, 0.05A max. drain 24/32 Vdc, 0.08A max. drain
Operating Temperature:	Minus 20°C to plus 70°C
Tolerances:	Pickup or dropout voltage @ 25°C nominal, ± 5%. Time delay @ 25°C, ± 10% or ± 0.05 sec., whichever is greater. Pickup or dropout voltage variation over temperature range – 20°C to + 55°C: 48/125 Vdc ± 1% max. 24/32 Vdc ± 2% max. Time delay variation over temperature range – 20°C to 55°C: ± 5%.
Transient Immunity:	More than 2500V, 1 MHz bursts at 400 Hz repetition rate, continuous (ANSI C37.90a SWC); fast transient, EMI test.
Dielectric:	2000 Vac RMS, 60 sec. all circuits to ground.
Seismic Capability:	More than 6g ZPA broadband multifrequency vibration without damage or malfunction (ANSI/IEEE C37.98)
Weight:	Unboxed – 4.0 lbs. (1.8 kg) Boxed – 4.7 lbs. (2.1 kg) Volume – 0.26 cubic feet

How To Specify

Voltage relay shall be Asea Brown Boveri Type 27/59 or approved equal, drawout case, capable of withstanding up to 6g ZPA seismic stress without damage or malfunction, at minimum voltage and time setting. A magnetic operation indicator shall be provided which retains position on loss of control power. Built-in means shall be provided to allow operational tests without additional equipment.

Further Information

List Prices: 41-020
Technical Data: TD 41-025
Instruction Book: IB 7.4.1.7-1
Other Protective Relays:
Application Selector Guide, TD 41-016

How To Order

For a complete listing of available versions of single and three phase voltage relays see TD 41-025.

Models are available for 24, 32, 48, or 125 Vdc control power. For 120 Vac potential applications and other control voltages, contact the nearest ABB Representative.

To place an order, or for further information, contact the nearest ABB Representative.

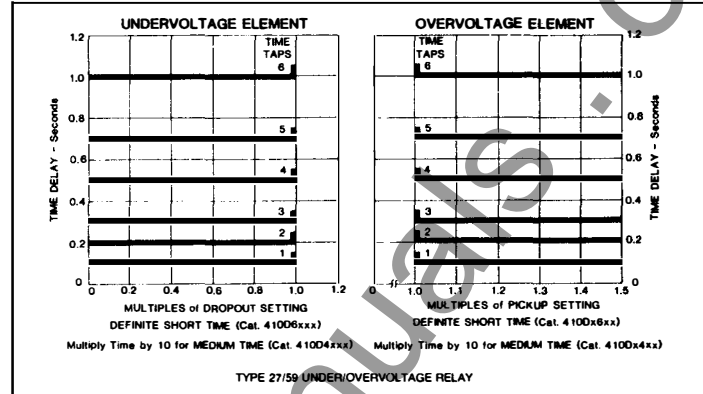

Figure 2 — Time-Voltage Characteristics.

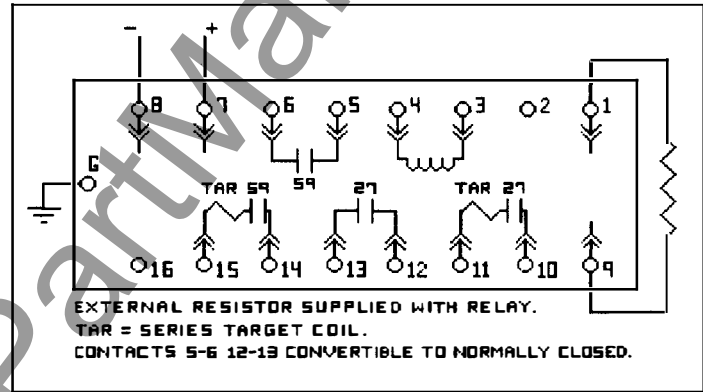

Figure 3 — Internal Connections.

July, 1992
Supersedes Descriptive Bulletin 41-235S
page 3, dated September, 1990
Mailed to: E, D, C/41-200B

Single Phase

CIRCUIT SHIELD[®] Type 27/59 Under/Overvoltage Relay

Type	Max. Voltage Rating	Undervoltage Element			Overvoltage Element			Output Contacts	Catalog Number See Note 2
		Pickup	Dropout	Time	Pickup	Curve	Time		
		Tap Range	Curve		Tap Range				
27/59	160V 45-400 Hz	60-110V	Inst.	—	100-150V	Inst.	—	2-A per function See Note 1	410D00X0
			Definite	0.1-1 sec.		Definite	0.1-1 sec.		410D60X0
				0.1-1 sec.		Inst.	—		410D40X0
				1-10 sec.		Definite	0.1-1 sec.		410D46X0
				1-10 sec.			1-10 sec.		410D44X0
				1-10 sec.			1-10 sec.		410D11X0
		30-55V	Inst.	—	60-85V	Inst.	—		410D21X0
			Definite	0.1-1 sec.		Definite	0.1-1 sec.		410D22X0
				0.1-1 sec.		Inst.	—		410D31X0
				1-10 sec.		Definite	0.1-1 sec.		410D32X0
				1-10 sec.			1-10 sec.		410D33X0
				1-10 sec.			1-10 sec.		410D10X0
30-55V	Inst.	—	100-150V	Inst.	—	410D20X0			
	Definite	0.1-1 sec.		Definite	0.1-1 sec.	410D26X0			
		0.1-1 sec.		Inst.	—	410D30X0			
		1-10 sec.		Definite	0.1-1 sec.	410D36X0			
		1-10 sec.			1-10 sec.	410D34X0			
		1-10 sec.			1-10 sec.				

Internal Connections, 16D410D (See note 1)

Internal Connection Diagrams

- Notes:**
- Contact 5-6 and 12-13 can be converted to normally closed. Selection is done by a movable link inside the relay.
 - Each of the listed catalog numbers contain an X for the control voltage designation. To complete the catalog number replace the X with the proper control voltage code digit:
48/110 Vdc 0
175 Vdc 1
48/125 Vdc 7
24/32 Vdc 9

Note: Refer to Instruction Book IB 7.4.1.7-1 for contact logic data. Instruction Book available upon request.

16D410D Type 27/59
Single-Phase Voltage Relays
Drawout Test Case

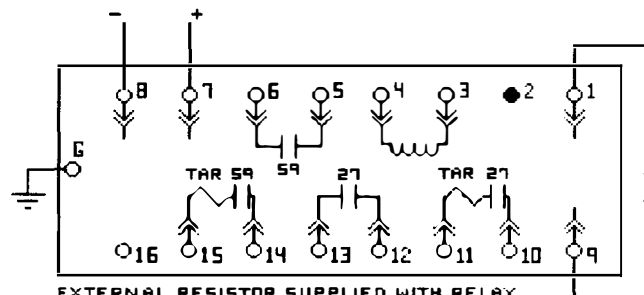

EXTERNAL RESISTOR SUPPLIED WITH RELAY.
TAR = SERIES TARGET COIL.
CONTACTS 5-6 12-13 CONVERTIBLE TO NORMALLY CLOSED.

To place an order, or for further information, contact the nearest ABB Representative.