

September 1995
Supersedes Descriptive Bulletin 41-530S,
pages 1-2, dated November 1990
Mailed to: E, D, C/41-500B

Device Number: 81

CIRCUIT SHIELD® Type 81 One and Two Step Frequency Relays



Application

The Type 81 Frequency Relay is a reliable solid state relay designed to provide accurate detection of abnormal frequency conditions on electrical power systems. The Type 81 is available in one stage and two stage models. Single step models are provided with means to select either underfrequency or overfrequency operation. Two stage models may be set up for either two steps of underfrequency detection, two steps of overfrequency detection or for overfrequency and underfrequency protection.

The relay has operating characteristics which make it ideal for application on closely coordinated system load shedding programs. The accuracy and stability of the relay characteristics permits settings much closer to system frequency, and closer steps between settings of relays in a load shedding program, than possible with electromechanical relays.

Another application is typical to large industrial plants which have some local generation. Normally, they depend on a tie line with a utility for some portion of their power needs. If the tie breaker at the utility end should open, the generator in the plant would be overloaded especially if it also attempts to pick up utility load tapped on the tie line. This overload causes an underfrequency condition on the industrial system. The Type 81 can be used to open the tie to the utility system and drop non-essential load. Essential loads can be maintained to the limit of the generator capability.

In DSG applications, typical protection includes a two step Type 81 providing an under and overfrequency window and a Type 27/59 providing an under and overvoltage window.

The relay uses digital counting techniques to provide an accurate measure of frequency. The time base measurement is provided by an extremely stable crystal oscillator reference. The set point accuracy is 0.008 Hz. The relay is provided with TRIP POINT and TIME DELAY settings. These settings are easily made on the front panel of the relay. For underfrequency operation the time delay period begins when the relay has counted three consecutive cycles below the trip frequency. The time delay counter will be fully reset if one cycle occurs above the trip frequency.

Features

- High accuracy
- Easy to set
- Low burden
- High seismic capability - 6g ZPA
- Transient immunity
- Available in one stage or two stage models
- 2 year warranty
- UL Recognized

Specifications

Operating Range:	Models available for: 45 - 52 Hz 54 - 63 Hz
Input Circuit Rating:	60-140 Vac
Undervoltage Cutoff Function:	Adjustable 60 - 100 volts Factory set at 60 volts
Burden:	0.7 VA
Control Power:	Models available for: 48/125 Vdc @ 0.07A, 48/110 Vdc @ 0.07A. 24/32, Vdc @ 0.11A, 110/220 Vdc @ 0.07A. 250 Vdc @ 0.06A
Operating Time:	Adjustable 1 - 99 cycles (must have 3 consecutive incorrect cycles before timing begins)
Output Contacts:	2 Form C contacts (for 1 step unit) 1 Form C contact for each step (for 2 step unit)
Output Circuit Rating:	@ 125 Vdc 30A tripping 5A continuous 1A opening resistive 0.3A opening inductive
Series Target Coil Rating:	30 Amp Tripping (1 Amp minimum trip circuit current required to set targets). For trip circuit currents below 1 Amp, .25 Amps minimum, add "-ST" to catalog number for sensitive target coil.
Temperature:	Minus 20 to Plus 70°C
Seismic Capability:	More than 6g ZPA biaxial multi-frequency vibration without damage or malfunction. (ANSI/IEEE C37.98)
Transient Immunity:	More than 3000 V, 1 MHz bursts at 60 Hz repetition rate, continuous (ANSI C37.90a - 1974); fast transient test; EMI immunity.
Dielectric:	2000 Vac RMS, 60 seconds all circuits to ground
Weight:	1 Step Unboxed - 3.7 lbs (1.7 Kg) Boxed - 4.3 lbs (2.0 Kg) 2 Step Unboxed - 3.9 lbs (1.8 Kg) Boxed - 4.6 lbs (2.1 Kg)
Volume:	0.26 cubic feet

How to Specify

Frequency Relay shall be Asea Brown Boveri Type 81 or approved equal. Relay operating point shall be settable in 0.05 Hz increments. Time delay shall be adjustable in 1 cycle increments. Relay shall be capable of withstanding 6g ZPA seismic stress without malfunctions. Operation indicator shall be provided. An undervoltage cutoff function shall be provided to block operation for low line voltage conditions.

How to Order

For a complete listing of available frequency relays, see TD 41-025.

To place an order, or for further information, contact your nearest ABB Representative.

Further Information

List Prices: PL 41-020
Technical Data: TD 41-025
Instruction Book: IB 7.4.1.7-5
Other Protective Relays:
Application Selector Guide, TD 41-016

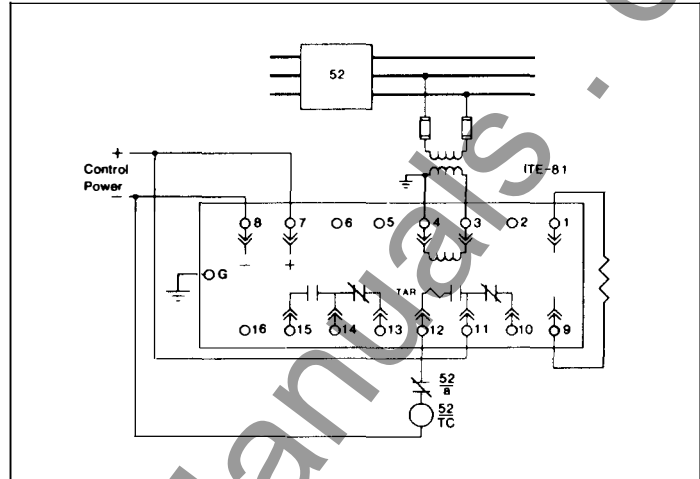

Typical Connections—1 Step Relay

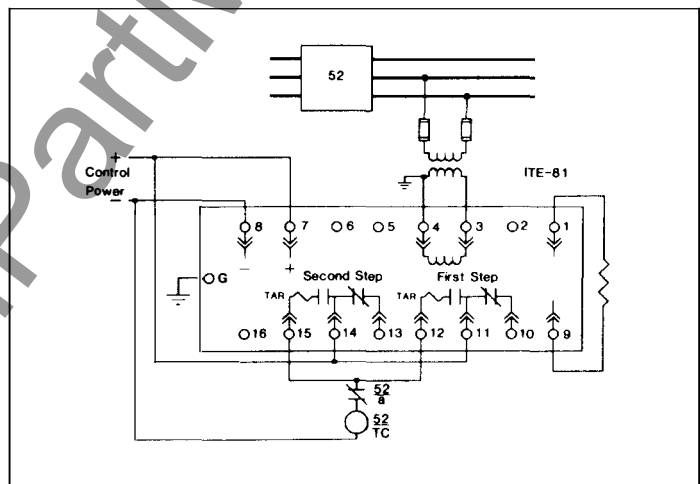

Typical Connections—2 Step Relay

June, 1994
Supersedes Descriptive Bulletin 41-530S, Page 3,
dated November, 1990
Mailed to: E, D, C/41-500B

CIRCUIT SHIELD[®]

Type 81 One and Two Step Frequency Relays

Type	Max. Voltage Rating	Number of Steps	Frequency Range	Operating Time	Output Contacts	Internal Connections	Control Voltage	Catalog Number	
81	140V	1	63-54 Hz	1-99 Cycles	2-C	16D422A	48/125 Vdc	422B1275	
							48/110 Vdc	422B1205	
							24/32 Vdc	422B1295	
							250 Vdc	422B1255	
							48/125 Vdc	422D1275	
		48/110 Vdc	422D1205						
		24/32 Vdc	422D1295						
		250 Vdc	422D1255						
		2	63-54 Hz	1-C for each step	52-45 Hz		16D422B	48/125 Vdc	422C1276
								48/110 Vdc	422C1206
24/32 Vdc	422C1296								
250 Vdc	422C1256								
48/125 Vdc	422E1276								
48/110 Vdc	422E1206								
24/32 Vdc	422E1296								
250 Vdc	422E1256								

① For other control voltages contact the nearest ABB Representative.

To place an order, or for further information, contact the nearest ABB Representative.

Internal Connection Diagrams

Note: Refer to Instruction Book IB 7.4.1.7-5 for contact logic data.

**16D422A Type 81
One-Step Frequency Relay
Drawout Test Case**

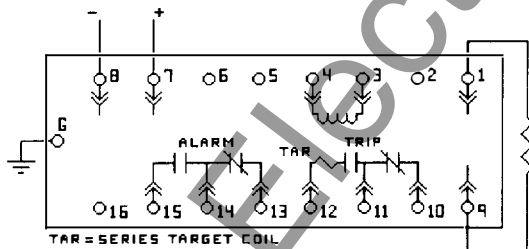

**16D422B Type 81
Two-Step Frequency Relay
Drawout Test Case**

