

July, 1991  
Supersedes DB 41-745C, pages 1-2,  
dated April, 1979  
Mailed to: E, D, C/41-700A

For Generator Field Protection

Device Number: 64

## Type DGF Field Ground Detection Relay

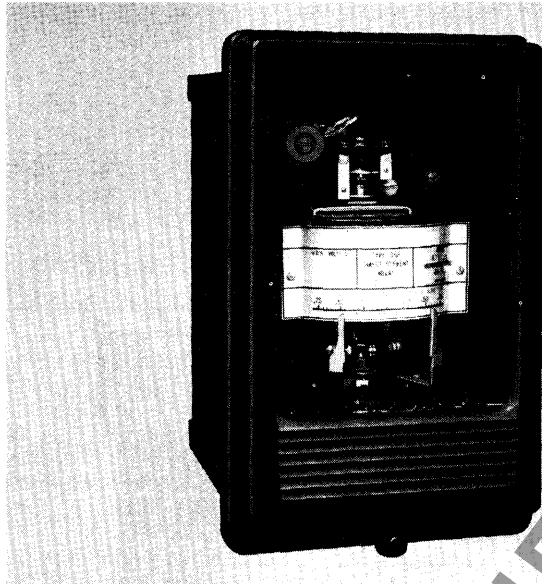

Internal Wiring (Front View), FT-21 Case

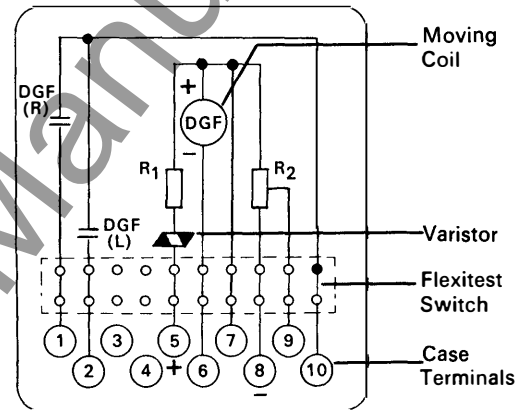

Fig. 1

183A113  
Sub. 6

### Application

Grounds in the field of a synchronous machine must be immediately detected, since the occurrence of a second ground might short circuit part of the field winding, and the resultant unbalance and vibration may damage the machine.

The DGF relay provides a reliable means for detecting grounds in the dc winding of the generator field. It uses a voltage divider consisting of a resistor and varistor connected across the field winding of the generator. The relay operating coil is connected from the mid-point of the voltage divider to ground. A ground in the generator field winding will cause current to flow through the moving coil of the DGF and operate the relay to trip or sound an alarm, as desired.

### Operation

The DGF relay scheme does not require an external voltage source. It consists of a sensitive d'Arsonval type dc relay (.75-0-.75 milliamperes), and suitable resistors.

As shown in the internal wiring diagram (Figure 1), the relay utilizes a voltage divider circuit consisting of linear resistors  $R_1$  and  $R_2$ , and a non-linear resistor (varistor) whose resistance decreases as the voltage applied across the resistor increases. If the field becomes grounded, a voltage will exist between point M (Figure 2) and the ground point. This voltage will vary depending upon the magnitude of the exciter voltage, and also the point where the field is grounded. The voltage will be maximum if

the field is grounded at either end of the field winding.

A null point will exist in the field winding where no voltage will be developed between point M and ground. If the divider resistance between M and the positive side of the exciter is equal to the divider resistance between M and the negative side of the exciter, the null point will be at the center of the field winding. The non-linear resistor varies the location of the null point as the exciter voltage varies, so that a ground can be detected at any point in the field winding. The voltage characteristic of the non-linear resistor is shown in Figure 4. In the 250 and 375 volt types an additional resistor ( $R_1$ ) is connected in series with the varistor to protect it from overvoltage.

The voltage divider is so proportioned that the field winding null position is located at mid-point when the field voltage is at 100% of rating; or at the 25% point from the negative end when 30% of the rated voltage is applied to the field. The outer curves in Figure 3 indicate the increase or decrease in supply voltage to close the relay contacts for a ground at the null point.

### Features

**Sensitivity:** The sensitive d'Arsonval movement provides detection of fault resistances up to 333,000 ohms.

**Full Protection:** Includes protection against grounds at the null points by the use of a non-linear resistor.

**Calibrated Dial:** Visible with the cover on so that the contact settings can be determined by inspection.

### Typical External Wiring, Center Zero Relay

Both contacts open when energized or de-energized.

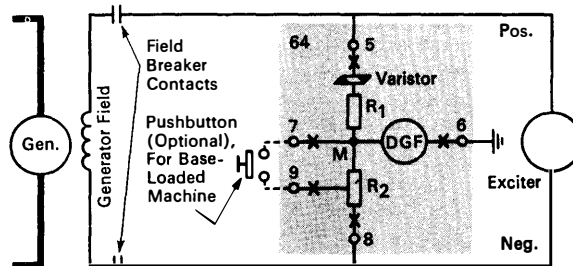
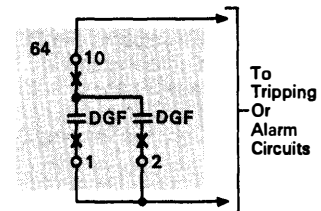

Fig. 2

64—Generator Field Ground Relay, Type DGF 183A465  
Sub. 3



Relay Voltage	$R_1$	$R_2$
80	2,240	15,000
125	0	45,000
160	0	23,000
250	5,000	23,000
375	10,000	23,000
440	27,000	45,000
500	28,000	45,000
600	0	45,000

**Operating Characteristic of DGF Relay**

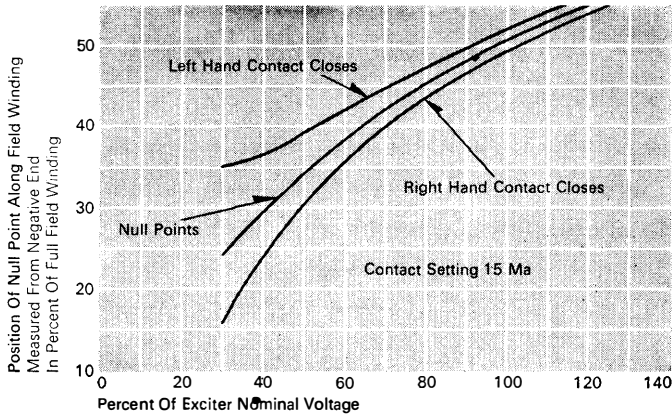

Fig. 3 471055

**Typical Voltage Characteristic of Non-Linear Resistor (Varistor) of DGF Relay**

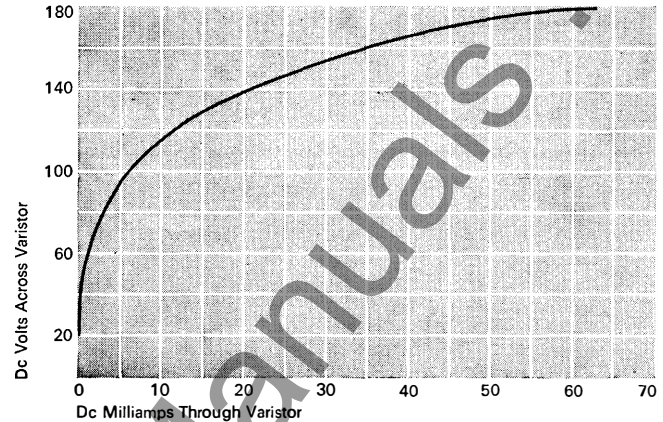

Fig. 4 471056

**Characteristics**

The operating unit of the DGF has an 0.75-0-0.75 milliamperere range. An adjustable contact is located on either side of the zero point. With a contact setting of 0.15 ma, a ground in the field winding can be detected for the following maximum fault resistances:

Exciter Rated Voltage: 125 volts dc  
Exciter Actual Voltage: 100 volts dc

Fault Location	Maximum Fault Resistance
(a) Positive side of field winding . . . . .	333,000 ohms
(b) Negative side of field winding . . . . .	300,000 ohms <sup>①</sup>
(c) 55% from negative side of field . . . . .	33,000 ohms
(d) 44% from negative side of field . . . . .	null point

① Approximate value.

For base-load machine applications where the generator excitation remains constant for a period of time, the null point can be shifted by connecting a pushbutton in the circuit as shown in Figure 2 to short out part of the linear resistors. The bridge becomes unbalanced and current will flow in the relay if a ground exists at the null point.

**Coil Data**

The adjustable range of the DGF operating coil is ±0.75 milliamperes dc. The moving coil resistance is 90 ohms at 25°C. An overload of 22.5 milliamperes can be applied continuously to the moving coil without damage.

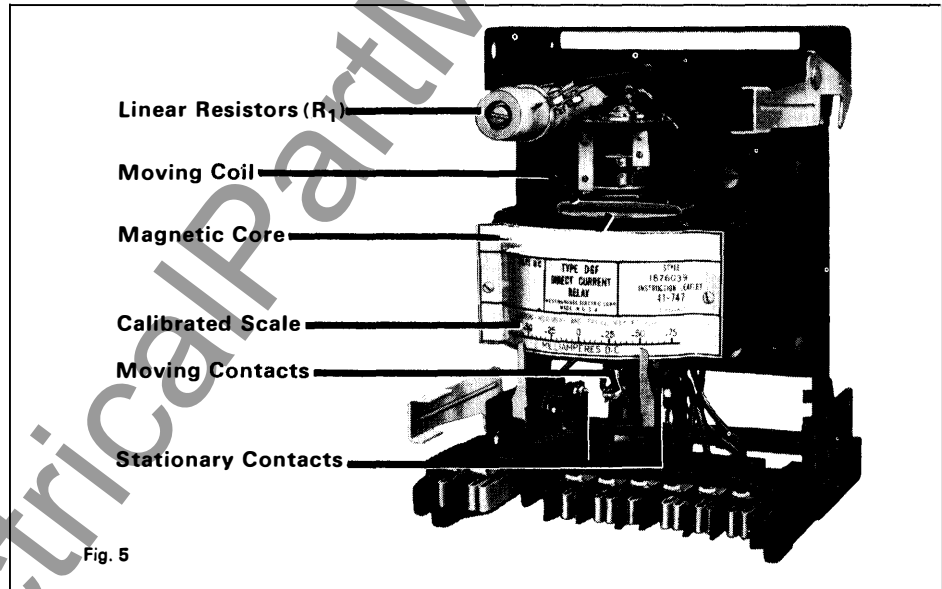

Fig. 5

**Contact Data**

**Moving:** The moving contacts will close a 1 ampere dc circuit, but should not be used to open appreciable current. An auxiliary type SG relay should be used to carry heavier currents.

An auxiliary contact (52a) must be provided on the circuit breaker to open the trip circuit when the breaker opens.

**Stationary:** Independently adjustable. Minimum setting is 0.15 ma either side of the moving contact.

Flexitest <sup>®</sup> Case Size	Weight, Lbs. (Approx.)		Domestic Shipping Carton Dimensions, Inches
	Net	Shipping	
FT-21	15	19	11½ x 8¾ x 13

**Further Information**

List Prices: PL 41-020  
 Technical Data: TD 41-025  
 Instructions: IL 41-747  
 Case Dimensions: DB 41-076  
 Other Protective Relays:  
 Application Selector Guide, TD 41-016



**ABB Power T&D Company Inc.**  
Relay Division  
Corl Springs, FL  
Allentown, PA

Descriptive Bulletin  
**41-701E**

Page 3

July, 1991  
Supersedes TD 41-020, Type DGF on  
page 261, dated November, 1987  
Mailed to: E, D, C/41-700A

For Generator Field Protection

## Type DGF Field Ground Detection Relay

### Field Ground Detection (Device Number: 64)

Type	Relay Scale	Field Voltage: Volts Dc	Relay Data		
			Internal Schematic	Style Number	Case Size
<b>DGF</b>	Center zero	80	183A113	288B857A14	<b>FT-21</b>
①	.75-0-.75	125		1876 039	
	mA dc	160		288B857A13	
		250		1878 175	
		375		1878 176	
		440		288B857A17	
		500		1961 087	
		600		288B857A16②	

① Has two self-contained resistors; one a varistor  
(non-linear).

② Includes external resistor.