



BE 1-50 INSTANTANEOUS OVERCURRENT RELAY

The BE1-50 Instantaneous Overcurrent Relay provides high speed detection of phase and/or ground faults. Optional output contacts allow the relay to be used as a phase selective fault detector.

FEATURES

- One relay can simultaneously monitor three phases plus neutral currents.
- Pickup setting is continuously adjustable over a wide range.
- Designed for use with 5A current transformer secondaries.
- Pickup Repeatability $\pm 2\%$ or 40 milliamps, whichever is greater.
- Independent output contacts for each sensing element.
- High speed operation.
- Operating power may be derived from the sensing input or an ac or dc source.
- Qualified to the requirements of
 - ANSI/IEEE C37.90-1978, C37.90a-1974, and IEC 255 for surge withstand capability;
 - ANSI/IEEE C37.90.1-198X for fast transient;
 - IEC 255-5 for impulse.
- UL Recognized under Standard 508, UL File #E97033.

APPLICATION

page 2

SPECIFICATIONS

Functional/Electrical
Mechanical Performance
page 3

EXTERNAL CONNECTIONS

Terminals/Diagrams

page 5

ORDERING

Procedure. Accessories.
Style Number Chart.

page 7

INSTRUCTION MANUAL

Reference
Publication Number

9 1710 00 990

INSTALLATION

Case dimensions and
mounting information.

See Bulletin SDA

B Basler Electric

P. O. BOX 269 HIGHLAND, ILLINOIS 62249, U.S.A. PHONE 618-654-2341 FAX 618-654-2351

UBC-5
10-87

APPLICATION

PURPOSE

Instantaneous overcurrent relays provide phase and ground fault protection for distribution circuits, generators, motors, transformers, and other major components of the power system. The BE1-50 has a wide range of pickup settings and input configurations to accommodate protection requirements throughout the system. The BE1-50 is available in single- or multi-phase units. Some of the possible applications are illustrated in Figure 1.

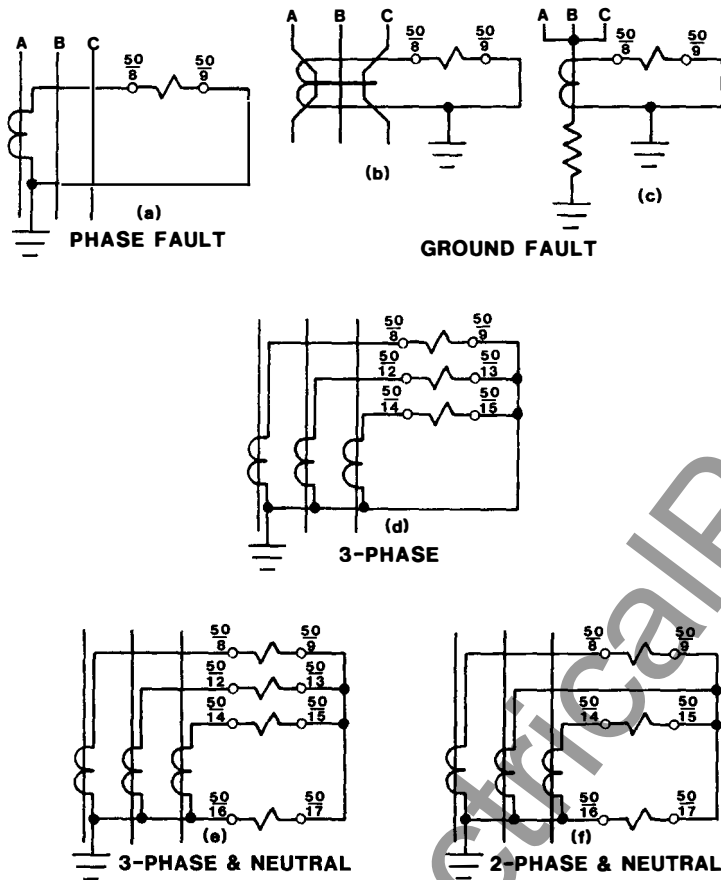

FIGURE 1. TYPICAL BE1-50 APPLICATIONS

GROUND FAULT DETECTION

The BE1-50 can be applied to monitor the zero sequence current indicative of a ground fault. The most sensitive method of ground fault protection utilizes a single current transformer through which all the conductors are passed (Figure 1b). Another method uses the residual connection of the three-phase CT's (Figures 1e and 1f), with the relay set higher than the normal system unbalance. The most direct method is to place a CT in the neutral of a grounded wye con-

nection for equipment such as a power transformer or generator (Figure 1c).

PHASE FAULT DETECTION

The BE1-50 can be used in two ways to detect phase faults. The first method is to place an instantaneous overcurrent element in each phase with the setting higher than expected load current for any power system element (Figures 1a, d, e, f).

The second method is called self-balancing differential protection (Figure 2). In this application, the two leads of each phase of the protected motor or generator are passed through the window of the associated phase current transformer so that the resulting secondary current under normal operating conditions is zero.

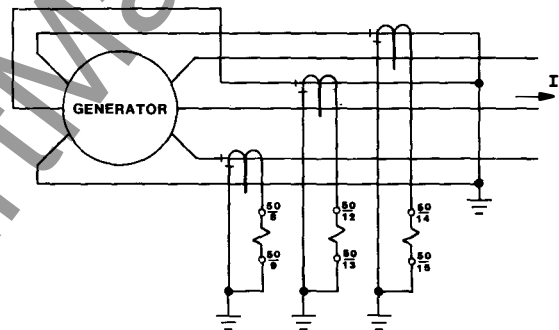

FIGURE 2. SELF-BALANCING DIFFERENTIAL PROTECTION

COMBINATION WITH OTHER PROTECTIVE DEVICES

Because the BE1-50 can provide complete phase and ground fault protection in one unit (and with independent settings for phase and ground), it is often used to supervise other relay functions, typically in distance and breaker failure applications.

In distance protection, the BE1-50 can be used to prevent misoperation of the distance relay for light loading conditions by requiring a minimum current level before enabling the output of the distance relay.

As a fault detector, it is particularly effective because of its sensitivity, speed, and drop out ratio.

FUNCTIONAL DESCRIPTION

The specifications on these pages define the many features and options that can be combined to exactly satisfy an application requirement. The block diagram in Figure 3 illustrates how the various standard features, as well as the options, function together.

SPECIFICATIONS

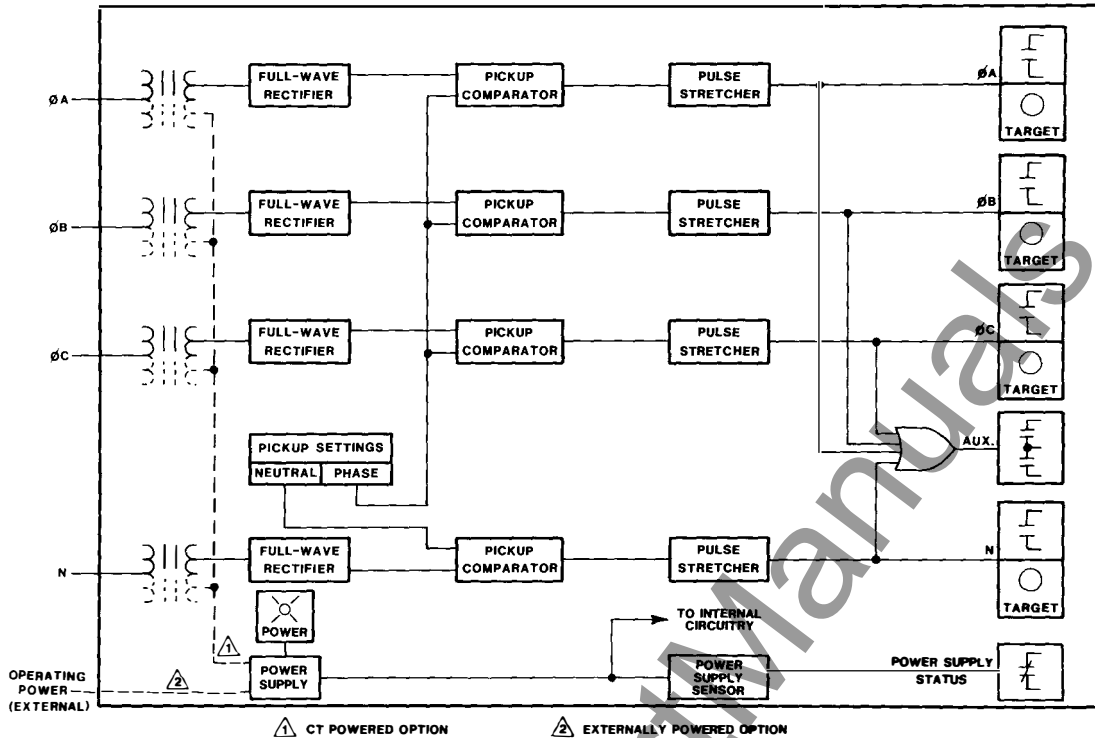

FIGURE 3. FUNCTIONAL BLOCK DIAGRAM

INPUTS

Current Sensing

System current transformers with standard 5 A secondaries supply the Instantaneous Overcurrent Relay's input transformers with single-phase, two-phase and neutral, three-phase, or three-phase and neutral currents from the monitored circuit. These currents are

individually scaled and rectified to represent the current magnitude of each monitored phase.

The sensing inputs, nominally rated at 50/60 Hz, have a frequency range of 40 to 70 Hz. Current ratings and sensing burdens depend on the sensing range and power supply type (as defined by the style number), and are shown in Table 1.

Table 1. SENSING INPUT CHARACTERISTICS

Power Supply	Sensing Range Designation		Actual Sensing Range	Maximum Ratings 50 or 60 Hz			
	For Phase	For Neutral		Current			Burden Per Input
				K*	1 Second	Continuous	
F, G or H	1	D	0.25 - 0.5 A	144	12.0 A	0.75 A	8.5 VA
	2	E	0.5 - 1.0 A	144	12.0 A	1.5 A	8.5 VA
	3	F	1.0 - 2.0 A	625	25.0 A	3 A	8.5 VA
	4	G	2.0 - 4.0 A	2500	50.0 A	6 A	8.5 VA
	5	H	4.0 - 8.0 A	10000	100 A	12 A	8.5 VA
	6	J	8.0 - 16.0 A	40000	200 A	20 A	9.5 VA
	7	K	16.0 - 32.0 A	90000	300 A	20 A	14.0 VA
O, P, R, S or T	2	E	0.25 - 2.0 A	10000	100 A	5 A	0.2 VA
	4	G	1.0 - 8.0 A	90000	300 A	10 A	0.6 VA
	6	J	4.0 - 32.0 A	90000	300 A	20 A	4.8 VA

* Short time ratings other than for 1 second may be calculated using the equation:

$$I = \sqrt{\frac{K}{t}}$$

where K equals the indicated value, t equals the time in seconds, and I equals maximum current.

SPECIFICATIONS (CONTINUED)

POWER SUPPLY

One of five externally-powered power supply types may be selected to provide internal operating power. They are described in Table 2. In addition, three CT power supply types are available which derive operating power from the sensing input current transformers: Type F (for single-phase sensing), Type G (for two-phase and neutral or three-phase sensing), and Type H (for three-phase and neutral sensing).

Table 2. EXTERNAL POWER SUPPLIES

Type	O	P	R	S*	T
Nominal Voltage	48 Vdc	125 Vdc 120 Vac	24 Vdc	48 Vdc 125 Vdc	250 Vdc 230 Vac
Burden	4.2 W	4.5 W 11.5 VA	4.5 W	4.2 W 4.5 W	8.0 W 24.0 VA

All ac references are at 50/60 Hz.

* The Type S power supply is field selectable for use with either 48 or 125 Vdc. Selection must be accomplished at the time of installation and prior to application of power.

PICKUP SETTINGS

A single front panel multiple-turn potentiometer, continuously adjustable over the range defined by the style number, establishes the phase current pickup level for each of the phase inputs. For relay styles sensing neutral current, a second continuously adjustable multiple-turn potentiometer is provided to establish the neutral current pickup level. Pickup is repeatable within 2% or 40 milliamps, whichever is greater. Dropout is within 2% of pickup, occurring in 50 milliseconds or less.

PICKUP COMPARATORS

The magnitude of each monitored current is compared to the pickup setting. When the pickup setting is exceeded the output relay is energized. (If more than one phase is monitored, AND if each input has an individual output, the associated relay is energized.)

TIMING

Maximum response time as measured from the onset of the overcurrent condition to output relay trip is 1-1/2 cycles of the monitored phase at 1-1/2 time the pickup setting.

TARGETS

Magnetically latched, manually reset target indicators are optionally available to indicate that an output has tripped. Either internally operated or current operated targets may be specified. Current operated targets require 0.2 A in the output trip circuit to actuate, and trip circuit current must not exceed 30 A for 0.2 seconds, 7 A for 2 minutes, and 3 A continuous. Current operated targets may be selected only when normally open (NO) output contacts have been specified.

OUTPUTS

A single set of output contacts is standard on all BE1-50 relays. On multiphase styles, additional outputs are optionally available. See Style Chart on page 8 for details.

All output contacts are rated as follows:

Resistive

120/240 Vac - make 30 A for 0.2 seconds, carry 7 A continuously, break 7 A.

250 Vdc - make and carry 30 A for 0.2 seconds, carry 7 A continuously, break 0.1 A.

500 Vdc - make and carry 15 A for 0.2 seconds, carry 7 A continuously, break 0.1 A.

Inductive

120/240 Vac, 125 Vdc, 250 Vdc - break 0.1 A
(L/R = 0.04).

Push-To-Energize Output Pushbuttons

Applying a thin non-conducting rod through a hole in the front panel energizes each output relay for testing the external trip circuits. Not available when Power Supply is F, G, or H.

POWER SUPPLY STATUS OUTPUT (OPTIONAL)

The power supply status output relay is energized and its NC output contact is opened when power is applied to the relay. Normal internal relay operating voltage maintains the power supply status output relay continuously energized with its output contact open. If the power supply output voltage falls below the requirements of proper operation, the power supply output relay is deenergized, closing the NC output contact.

SURGE WITHSTAND CAPABILITY

Qualified to ANSI/IEEE C37.90a-1974, Surge Withstand Capability Test and IEC 255, Impulse Test and Dielectric Test.

MECHANICAL

Operating Temperature

-40°C (-40°F) to +70°C (+158°F)

Storage Temperature

-65°C (-85°F) to +100°C (+212°F)

Weight

17.5 pounds maximum

Shock

In standard tests the relay has withstood 15g in each of three mutually perpendicular axes without structural damage or degradation of performance.

Vibration

In standard tests the relay has withstood 15g in each of three mutually perpendicular axes without structural damage or degradation of performance.

CONNECTIONS

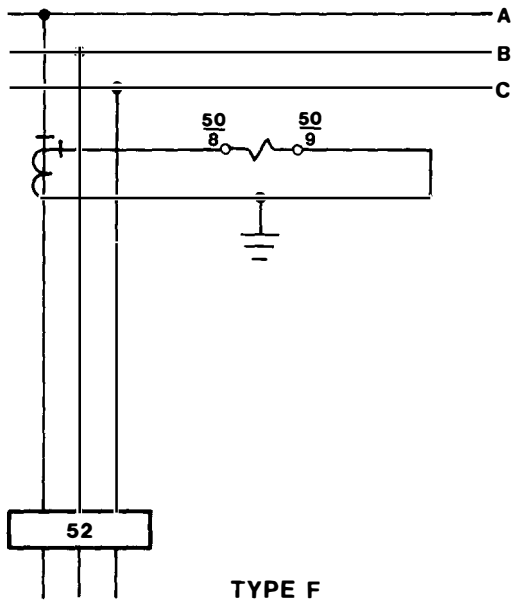

TYPE F
SINGLE-PHASE

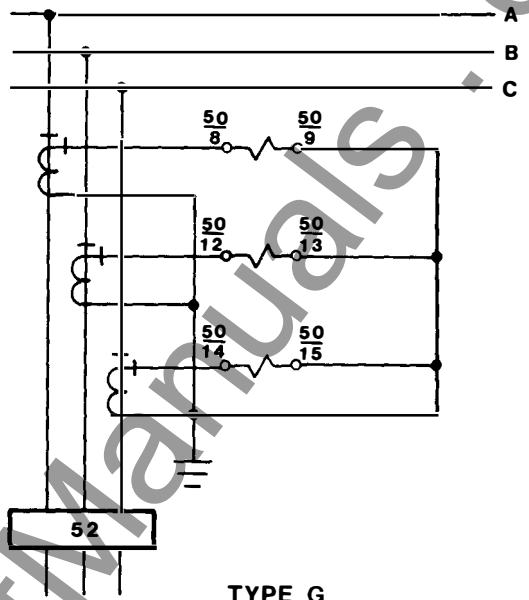

TYPE G
THREE-PHASE

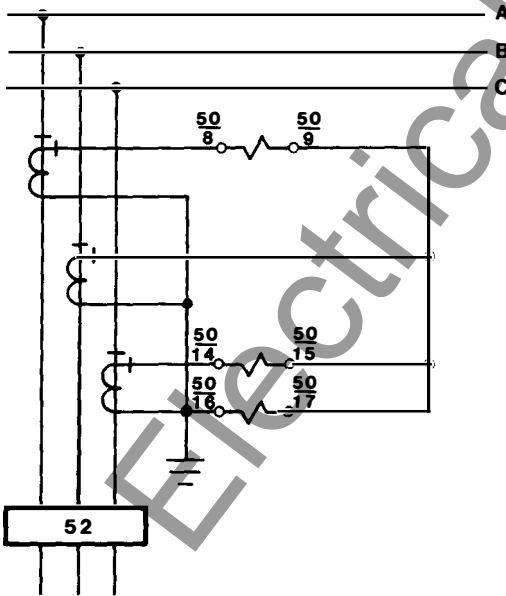

TYPE E
TWO-PHASE AND NEUTRAL

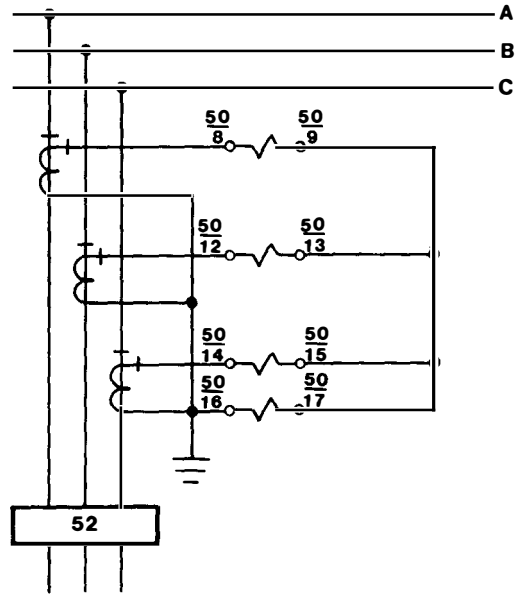

TYPE J
THREE-PHASE AND NEUTRAL

FIGURE 4. CURRENT SENSING

CONNECTIONS

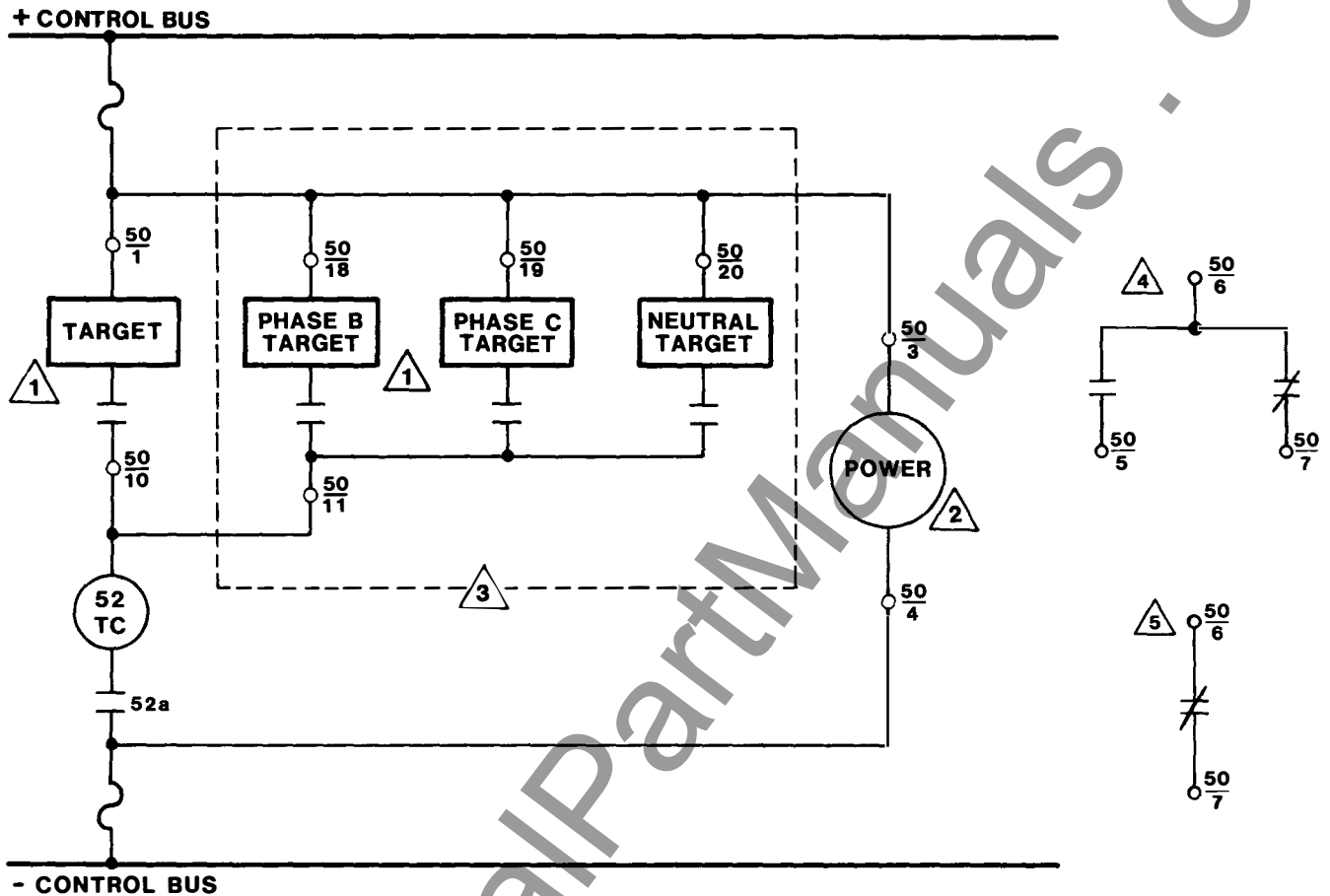

LEGEND:

- 50 Instantaneous Overcurrent Relay
- 52 Circuit Breaker
- TC Trip Coil
- 52a Circuit Breaker Auxiliary Contacts

- ① Current operated Targets shown
- ② Externally powered power supplies (Types O,P,R,S, and T only.)
- ③ Additional output relays are an available option for multi-phase units.
- ④ Auxiliary Output is provided when Option 3 is 1, 2, or 5.
- ⑤ Power Supply Status Output is provided when Option 3 is 6.

FIGURE 5. CONTROL CIRCUITS

ORDERING

MODEL NUMBER

BE1-50 Instantaneous Overcurrent Relay

STYLE NUMBER

The style number appears on the front panel, drawout cradle, and inside the case assembly. This style number is an alphanumeric combination of characters identifying the features included in a particular unit. The sample style number below illustrates the manner in which the various features are designated. The Style Number Identification Chart (page 8) defines each of the options and characteristics available for this device.

SAMPLE STYLE NUMBER: J6J A1H JOE1F

The style number above describes a BE1-50 Instantaneous Overcurrent Relay having the following features.

Sensing Input Type (J) Three-phase and neutral
 Sensing Input Range (6) 8.0 to 16.0 A (since power supply is H)

Output (J) Four normally open output relays
 Timing (A1) Instantaneous
 Power Supply (H) Current transformer for use with three-phase and neutral sensing
 Target (J) Four internally operated targets
 Option 1 (O) None
 Option 2 (E) 0.5-1.0 A neutral sensing range
 Option 3 (1) Normally open auxiliary output relay
 Option 4 (F) Semi-flush mounting

NOTE: The description of a complete relay must include both the model number and the style number.

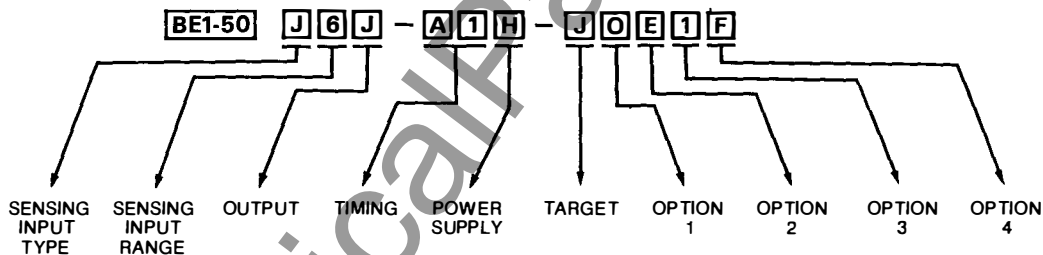

SAMPLE STYLE NUMBER ILLUSTRATED

HOW TO ORDER

Designate the model number, followed by the complete style number.

BE1-50 Style No.

Complete the Style Number by selecting one feature from each column of the Style Number Identification Chart and entering its designation letter or number into the appropriate square. (Two squares are used to indicate time delay characteristics.) All squares must be completed.

STANDARD ACCESSORIES

The following accessories are available for the BE1-50 Instantaneous Overcurrent Relay.

Test Plug

To allow testing of the relay without removing system wiring, order two test plugs, Basler Electric part number 10095.

Extender Board

The extender board permits troubleshooting of the printed circuit boards outside of the relay cradle. Order Basler Electric part number 9 1655 00 100.

STYLE NUMBER IDENTIFICATION CHART

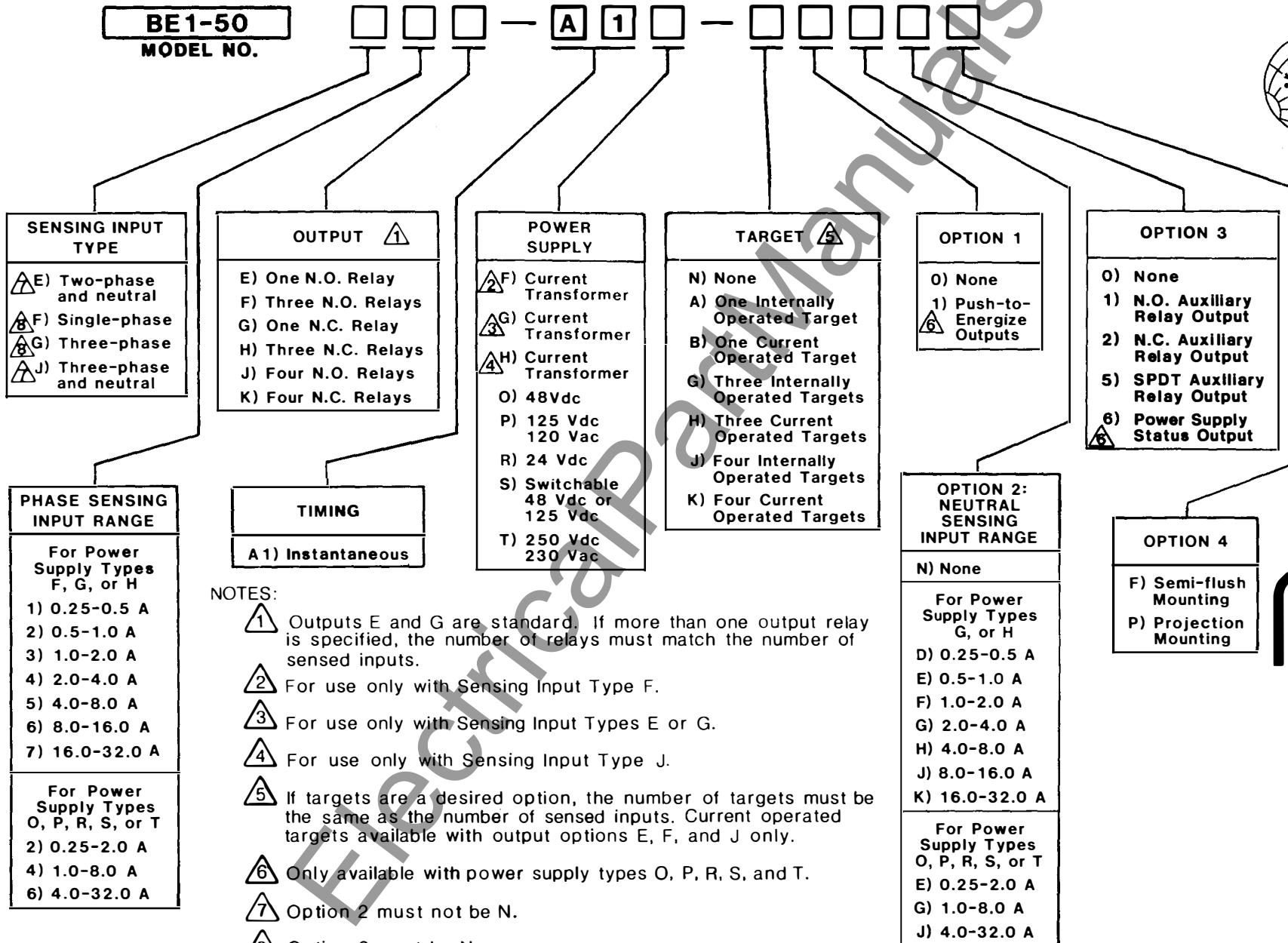

NOTES:

- 1) Outputs E and G are standard. If more than one output relay is specified, the number of relays must match the number of sensed inputs.
- 2) For use only with Sensing Input Type F.
- 3) For use only with Sensing Input Types E or G.
- 4) For use only with Sensing Input Type J.
- 5) If targets are a desired option, the number of targets must be the same as the number of sensed inputs. Current operated targets available with output options E, F, and J only.
- 6) Only available with power supply types O, P, R, S, and T.
- 7) Option 2 must not be N.
- 8) Option 2 must be N.
9. All relays are supplied in an S1 size case.



Basler Electric

ROUTE 143, BOX 269, HIGHLAND, ILLINOIS U.S.A. 62249
 PHONE 618-654-2341 FAX 618-654-2351
 P.A.E. Les Pins, 67319 Wassebonne Cedex FRANCE
 PHONE (33-3-88) 87-1010 FAX (33-3-88) 87-0808
<http://www.basler.com>, info@basler.com

Printed in U.S.A.