

## BE1-46N NEGATIVE SEQUENCE OVERCURRENT RELAY

The BE1-46N Negative Sequence Overcurrent Relay is microprocessor based to provide a new standard in versatility and control in protecting machines against phase unbalance.

### FEATURES

- Unaffected by frequency variations of  $\pm 10\%$ .
- Operating time adapts to rotor temperature effects due to prior unbalance heating.
- Relay operating characteristics are expressed as:  $\int I_2^2 dt \leq K$
- Low sensing and supply burdens.
- Optional remote  $I_2$  meter and oscillograph start contact.
- Qualified to the requirements of
  - ANSI/IEEE C37.90.1-1989 for surge withstand capability,
  - ANSI/IEEE C37.90-1989 for dielectric tests,
  - IEC 255-5 for impulse.

### ADDITIONAL INFORMATION

#### INSTRUCTION MANUAL

Request publication 9-1700-00-990

#### STANDARDS, DIMENSIONS & ACCESSORIES

Request bulletin SDA

#### APPLICATION

Page 2

#### SPECIFICATIONS

Page 2-5

#### EXTERNAL CONNECTIONS

Page 6

#### ORDERING

Page 7

## APPLICATION

### PURPOSE

The BE1-46N responds to the negative phase sequence current which flows during unbalance faults or loads on a power system. The BE1-46N is used to protect machines against excessive heating damage due to prolonged current unbalance.

Unbalanced loading or faults on the power system which are not removed or isolated can cause serious damage to rotating machinery. The BE1-46N Negative Sequence Overcurrent Relay protects the machine from damage when the protective scheme, or other external action to the generator, fails to eliminate the unbalanced condition.

The principles of symmetrical components allow an unbalanced system to be considered as three separate, balanced subsystems. These balanced subsystems may then be analyzed as independent quantities. These quantities are the positive, negative and zero sequence components.

The positive sequence component ( $I_1$ ), represents the quantity which has normal phase rotation and produces no adverse effect on machinery. An ideally balanced system contains only positive sequence phase currents and voltages.

The negative sequence component ( $I_2$ ), on the other hand, produces a stator magnetic flux that has the same rotational speed as the motor flux, but in the opposite direction. This flux is cut by the rotor at twice the rotational speed. This induces double eddy currents into the rotor iron and windings, and if allowed to persist, could result in severe damage to the machine.

The zero sequence component ( $I_0$ ) also has no direct adverse effect on machines as it produces no appreciable magnetic flux and causes no excessive heating.

The BE1-46N, due to its built-in selectivity and sensitivity independent of frequency deviations, can precisely monitor the magnitude and control the duration of the negative sequence current component. The BE1-46N incorporates a time delay that replicates the generator's heating characteristics and provides an alarm element to allow optimum use of the relay's time delay and provide the maximum amount of time to locate and isolate the fault while avoiding damage to the generator.

The BE1-46N is specifically designed for use with any polyphase machine having a  $I_2^2t$  limit between 1 and 99, and where the quality of desired system protection is of utmost importance. The relay is thus applicable to virtually all machines regardless of size or type of construction.

## SPECIFICATIONS

### FUNCTIONAL DESCRIPTION

The specifications on these pages define the many features and options that can be combined to exactly satisfy an application requirement. The block diagram Figure 1, illustrates how the various standard features, as well as the options, function together.

### INPUTS

#### Current Sensing

5 Ampere CT: 5A nominal (50/60Hz) current transformers; 10A continuous current, 250A one second current, 2VA burden maximum per phase, frequency range 45 to 55 Hz for 50Hz systems and 55 to 65Hz for 60Hz systems.

1 Ampere CT: 1A nominal (60Hz) current transformers; 2A continuous current, 50A one second current, 2VA burden maximum per phase, frequency range 45 to 55Hz for 50Hz systems and 55 to 65Hz for 60Hz systems.

## SPECIFICATIONS (Continued)

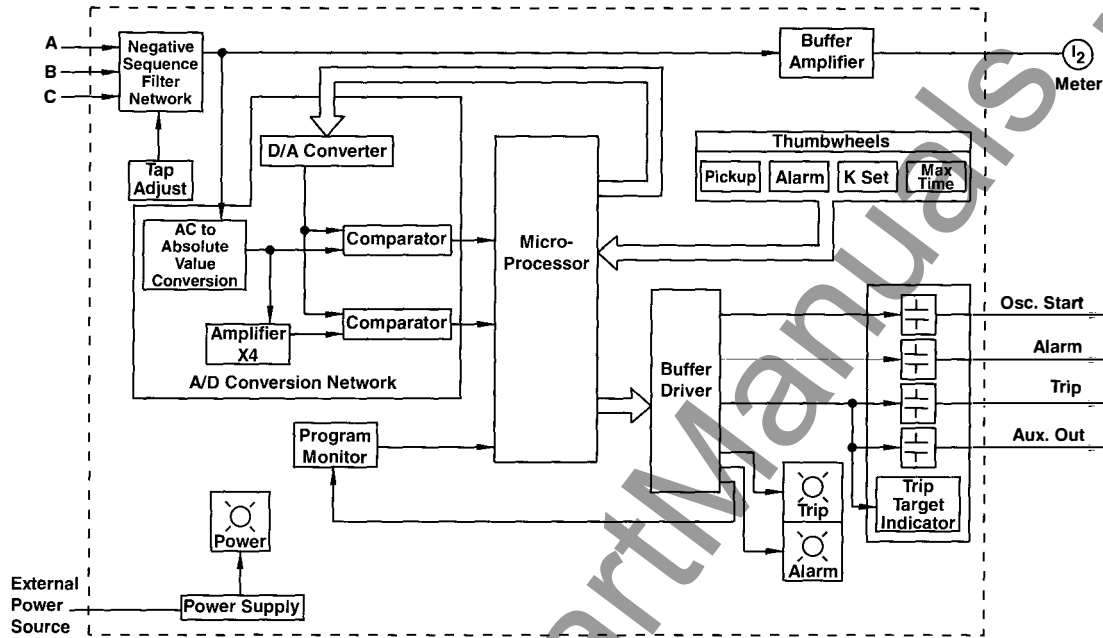

Figure 1 - Functional Block Diagram

### Power Supply

One of five power supply types may be selected to provide internal operating power. They are described in Table 1.

**TABLE 1. POWER SUPPLY OPTIONS**

Type	O	P	R	S	T
Nominal Voltage	48Vdc	125Vdc 120Vac	24Vdc	48Vdc 125Vdc	250Vdc 230Vac
Burden	6.96W	7.60W 18.01VA	7.38W	6.96W 7.60VA	10.25W 28.03VA

### ALARM AND TRIP LEVEL DETECTORS

The representative per-unit (p.u.) negative sequence voltage established by the TAP ADJUST switch is compared to the front panel ALARM setting by the alarm level detector circuitry.

Likewise, the p.u. voltage is compared to the front panel PICKUP setting by the trip level detector circuitry. The range of the ALARM and PICKUP settings is 1 to 50% negative sequence with an accuracy of  $\pm 0.5\%$  of  $I_2$ , negative sequence current.

## SPECIFICATIONS (Continued)

### ALARM TIMING

Once the ALARM setting has been exceeded, a red front panel LED is illuminated. After a time delay of 3 seconds an output contact is operated. The 3 second time delay is factor set to prevent nuisance alarms for transient conditions.

### PICKUP TIME DELAY

Once the front panel PICKUP setting has been exceeded, a red LED is illuminated and the pickup time delay is started. The pickup time delay is determined by integrating  $I_2^2 dt$ . The elapsed time of the time delay is reached when the  $I_2^2 dt$  equals or exceeds the front panel setting for K. The range of the K-SET is 1 to 99, which allows the negative sequence relay to be matched to a large variety of machines. The accuracy of the timing function is  $\pm 5\%$  of the characteristic curve, see Figure 2. When the value of the negative sequence current falls below the setting, the integrator resets at a linear rate of 2.5 seconds per percent of full scale trip time. This stimulates the cooling characteristics of the protected machine. Once the pickup time delay has been exceeded an output contact is energized.

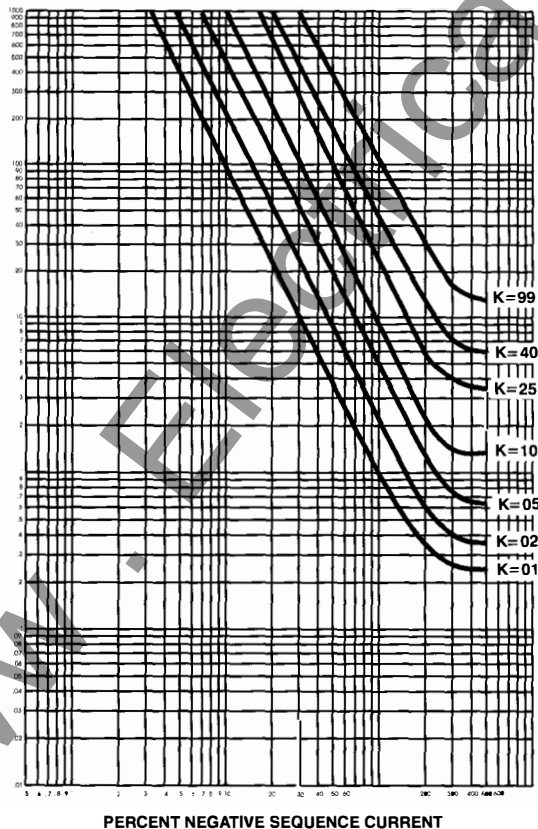

Figure 2 - Characteristic Curve

### MINIMUM TRIP TIMER

The minimum trip timer is initiated when the PICKUP setting is exceeded and also resets when the percent of negative sequence current falls below the PICKUP setting. The time is factory set at 200 milliseconds. This time ensures a minimum operate time in the event the integrator resets just prior to tripping and the negative sequence current has once again exceeded the PICKUP setting.

### MAXIMUM TRIP TIMER

The maximum trip timer is initiated when the PICKUP setting is exceeded and resets when the percent of negative sequence current falls below the PICKUP setting. The time is adjustable over the range of 10 to 990 seconds with an accuracy of  $\pm 5\%$  of the setting.

### TARGETS

Magnetically latched, manually reset, target indicators are optionally available to indicate that an output has tripped. Either internally operated or current operated targets may be specified. Current operated targets require 0.2 A in the output trip circuit to actuate, and trip circuit current must not exceed 30 A for 0.2 seconds, 7 A for 2 minutes, and 3 A continuous. Current operated targets may be selected only when normally open (NO) contacts have been specified.

### OUTPUTS

#### Alarm and Trip

Alarm and Trip output contacts, as well as auxiliary output contacts are rated as follows:

#### Resistive

120/240Vac - make 30A for 0.2 seconds, carry 7A continuously, break 7A.

250Vdc - make and carry 30A for 0.2 seconds, carry 7A continuously, break 0.3A.

#### Inductive

120/240Vac, 125/250Vdc - Make and carry 30A for 0.2 seconds, carry 7A continuously, and break 0.3A. (L/R=0.04).

## SPECIFICATIONS (continued)

### Oscillograph Start

The BE1-46N has an optionally available oscillograph start function. This function provides a contact output (NO or NC) when the level of negative sequence current has exceeded the pickup point and the minimum trip timer has timed out. Oscillograph start output contacts are rated at 0.5 A at 48 Vdc.

### Remote Meter

The BE1-46N has an optionally available remote external meter that displays the magnitude of the sensed negative sequence current as a percentage of the nominal full load current. Full scale deflection of the meter will correspond to 50 percent. When this option is selected a standard 4.5 inch switchboard type meter will be shipped with the relay package. See Figure 3. Meter is accurate to within  $\pm 1\%$  over the temperature range.

NOTE: Connection between relay and meter should be made using no less than a 20 gauge, twisted shielded conductor grounded at the relay case.

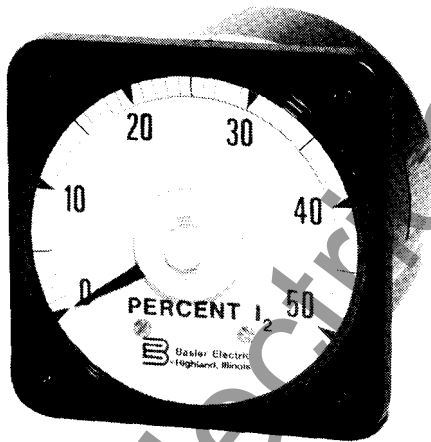

Figure 3 - Remote Meter

### Push-to-Energize-Output Pushbuttons

Applying a thin non-conducting rod through a hole in the front panel energizes each output relay for testing the external trip circuits.

### MICROPROCESSOR

The heart of the BE1-46N is its 8-bit, low power, CMOS microprocessor. The microprocessor is ultimately responsible for the control of all timing and comparison functions of the relay, and is capable of providing these functions with high accuracy. Greater selectivity,

sensitivity and speed can be achieved through the use of microprocessor technology and in the case of the BE1-46N, will provide reliable and dependable operation for years of secure service.

### PROGRAM MONITOR

The program monitor provides a dual function for the BE1-46N relay. As the relay is being powered up, the program monitor ensures that the program begins from its initial starting point and that any or all old data that may have been present is cleared.

During normal relay operation, the program requires the microprocessor to output a series of pulses at regular intervals. The program monitor senses these pulses and, in the event the pulses are disrupted in any way, causes the microprocessor to reset to its initial state, clearing all old data and re-initializing the program.

### SURGE WITHSTAND CAPABILITY

Qualified to ANSI/IEEE C37.90.1-1989 Surge Withstand Capability Test, IEC 255 Impulse Test and ANSI/IEEE C37.90-1989 Dielectric Test.

### MECHANICAL

#### Meter Temperature Range

-5°C to +45°C

#### Operating Temperature

-40°C (-40°F) to +70°C (+158°F)

#### Storage Temperature

-65°C (-85°F) to +100°C (+212°F)

#### Weight

13.5 pounds maximum

#### Shock

In standard tests, the relay has withstood 15g in each of three mutually perpendicular axes without structural damage or degradation of performance.

#### Vibration

In standard tests, the relay has withstood 2g in each of three mutually perpendicular axes swept over the range of 10 to 500 Hz for a total of six sweeps, 15 minutes for each sweep, without structural damage or degradation of performance.

## CONNECTIONS

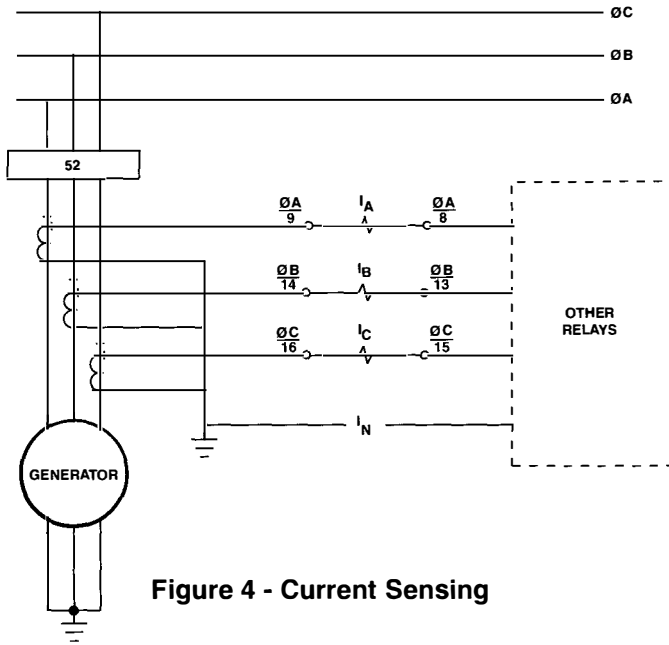

Figure 4 - Current Sensing

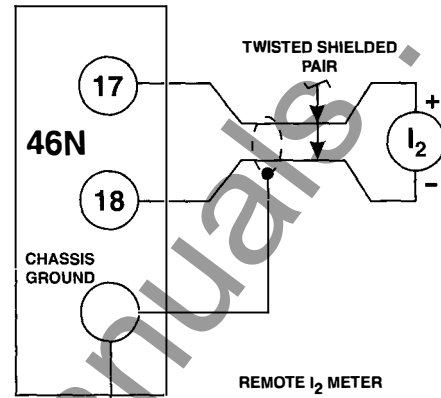
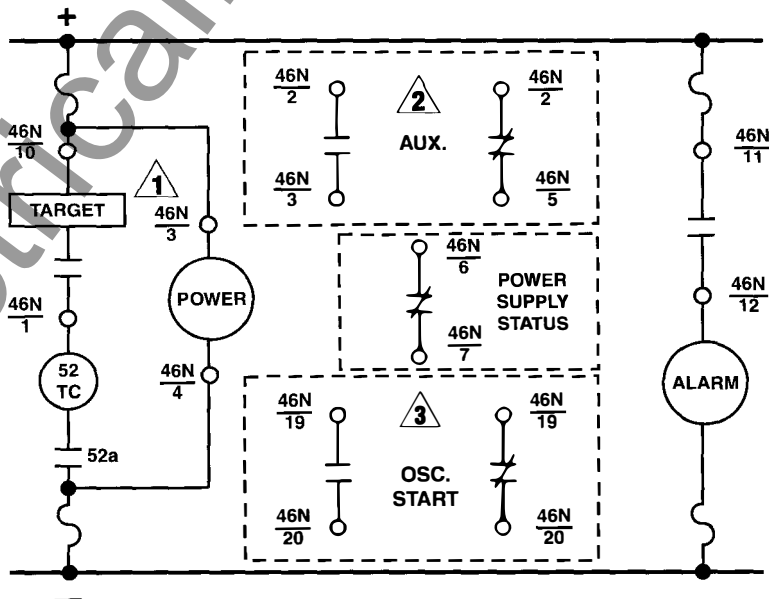

Figure 5 - Remote Meter

LEGEND:

- 46N - Negative Sequence Overcurrent relay
- 52 - Circuit breaker
- 52a - Circuit breaker auxiliary contacts
- TC - Trip coil



- ① Optional, internally operated or current operated. Current operated shown.
- ② Optional, auxiliary output contacts (NO or NC).
- ③ Optional, oscillograph start contacts (NO or NC)

Figure 6 - Control Circuits

# ORDERING

## MODEL NUMBER

BE1-46N Negative Sequence Overcurrent Relay

## STYLE NUMBER

The style number appears on the front panel, drawout cradle, and inside the case assembly. This style number is an alphanumeric combination of characters identifying the features included in a particular unit. The sample style number below illustrates the manner in which the various features are designated. The Style Number Identification Chart (page 8) defines each of the options and characteristics available for this device.

### SAMPLE STYLE NUMBER: G1H B8S B1B1F

The style number above describes a BE1-46N negative sequence overcurrent relay having the following features.

- Sensing Input Type (G) Three-phase negative sequence current
- Sensing Input Range (1) 3 to 5A nominal at 60 Hz.
- Output (H) Alarm output NC and trip output NO

- Timing (B8)  $I_2^2t$  timing characteristic
- Power Supply (S) 48 or 125Vdc power supply
- Target (B) One current operated target indicator
- Option 1 (1) Remote  $I_2$  meter
- Option 2 (B) Oscillograph start function NC contacts
- Option 3 (1) Auxiliary output contact NO
- Option 4 (F) Semi-flush mounting

NOTE: The description of a complete relay must include both the model number and the style number.

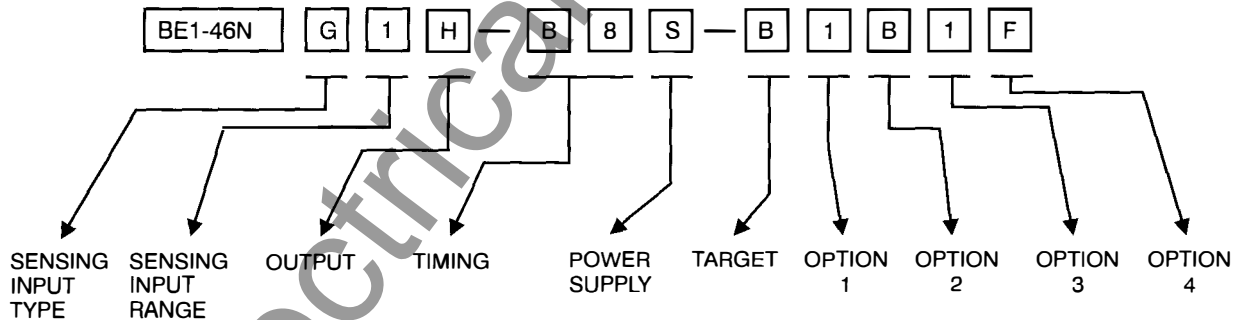

SAMPLE STYLE NUMBER ILLUSTRATED

## HOW TO ORDER:

Designate the model number followed by the complete Style Number.

BE1-46N Style Number □□□-□□□-□□□□□

Complete the Style Number by selecting one feature from each column of the Style Number Identification Chart and entering its designation letter or number into the appropriate square. (Two squares are used to indicate time delay characteristics.) All squares must be completed.

## STANDARD ACCESSORIES:

The following accessories are available for the BE1-46N, Negative Sequence Overcurrent Relay.

### Test Plug

To allow testing of the relay without removing system wiring, order two test plugs, Basler Electric part number 10095.

### Extender Board

The extender board permits troubleshooting of the printed circuit boards outside of the relay cradle. Order Basler Electric part number 9 1655 00 100.

## STYLE NUMBER IDENTIFICATION CHART BE1-46N

