

**BE1-50/51B
SELF POWERED
TIME OVERCURRENT
RELAY**

Direct replacement "plug and play"
relays are available.
See Product Bulletin UHK.

The BE1-50/51B Time Overcurrent Relay provides economical overload and fault protection for generators, transformers, lines and motors.

ADVANTAGES

- Self powered from 50/60Hz systems, available for 5 or 1 amp CT secondaries.
- Ten field selectable curves.
- Independent instantaneous overcurrent function.
- Drawout construction, testable in the case.
- Qualified to the requirements of:
 - IEEE C37.90-1989, C37.90.1-1989, C37.90.2-1989, UL508
- 200 series adds:
 - Patented integrating reset characteristic, even when current goes to zero.
Replicates electromechanical reset for all applications.
 - Five additional field selectable curves, for a total of 15.
- Five year warranty.

ADDITIONAL INFORMATION

INSTRUCTION MANUAL

Request Publication 9252000991

TIMING CURVES

Request Publication 9252000998 or 9252000894 for Basler-equivalent IAC curves

Request Publication 9252000999 for Basler-equivalent CO and BS142 curves

STANDARDS, DIMENSIONS and ACCESSORIES

Request Publication SDA

**FEATURES and
APPLICATION**
Page 2

**FUNCTIONAL
DESCRIPTION**
Pages 2-5

SPECIFICATIONS
Pages 6 and 7

**ORDERING
INFORMATION**
Page 8

FEATURES

- 15 field selectable, inverse, fixed time and British Standard (BS142) time overcurrent curves on 200 series relays (10 on 100 series).
- Time characteristics extend to 40 X Pickup.
- Instantaneous overcurrent function.
- Wide setting ranges:

Time Overcurrent:	0.5 to 15.9 (5 Amp Unit)
	0.1 to 3.18 (1 Amp Unit)
Inst. Overcurrent:	2.0 to 99 (5 Amp Unit)
	0.2 to 19.8 (1 Amp Unit)
- Current pickup accuracy $\pm 2\%$.
- Timing accuracy $\pm 2\%$.
- Continuous automatic calibration.
- Less than 10% transient overreach.
- Zero Pickup setting for safety during installation.
- Timed Overcurrent Reset - Selectable Instantaneous or Decay Characteristic (200 series relays only).
- 5VA burden (at nominal) self powered from 50/60 Hz systems, utilizes standard 5 or 1 Amp CT secondaries.
- Drawout construction.
- Manual method for trip circuit testing.
- Standard magnetically latched targets for TOC and IOC.
- Direct reading front panel controls.
- Positive visual indication that microprocessor is executing code.
- UL recognized under standard 508.
- Qualified to the requirements of:
 - IEEE C37.90.1-1989 for SWC.
 - IEEE C37.90.2-1989 for RFI.
 - IEC 255-5 for impulse.

APPLICATION

The BE1-50/51B is a single phase self powered, micro-processor based time overcurrent relay. The relay is designed for use in applications requiring time delayed coordination for phase or ground overcurrent conditions.

The relay can be used to provide coordinated protection for overhead and underground distribution circuits. Other applications include overcurrent back-up protection for transformers and generators, the protection of neutral grounding resistors and reactors, and motors.

Since all of the time-current characteristics are included within the relay, a standard relay may be ordered before the coordination study is completed, thereby allowing the physical construction to proceed. 100 series relays have curves that match ABB/Westinghouse time curve shape. 200 series adds five unique GE-type curves. See Table 2 for available curve types. This is also an advantage as changes in the system configuration or coordination may be accomplished without a hardware change.

Models are included (200 series) which have memory to replicate the decaying reset of electromechanical relays even when power to the relay is lost. Use the 200 series for applications that require coordination with the resetting of nearby electromechanical relays.

The instantaneous overcurrent element is standard in the relay. This element is designed to minimize transient overreach. The instantaneous element includes selectable delay characteristics for improved coordination with downstream devices and customer requirements.

FUNCTIONAL DESCRIPTION

CURRENT INPUT

A single phase of ac current from a 5 Amp, or 1 Amp, 50/60 Hz, system current transformer (CT) is applied to the BE1-50/51B. This input current provides both the power and sensing quantity for the relay.

The current applied to the relay provides the energy for the internal power supply. When sufficient current is available, the Active/Pickup LED will turn green. In applications where circuit loading conditions are less than that required to illuminate the LED, the relay remains operable and will provide overcurrent protection.

The sensing input transformer provides the quantity to be scaled and measured by the Time and Instantaneous functions. Ranges, ratings, and accuracies apply as described in Table 1.

Scaling of the input signal is accomplished by separate networks for the time and instantaneous functions. The scale factors are established by the front panel pick-up settings. Pickup settings of 00 provide maximum sensitivity as a safety precaution for the installation process. Pickup will occur when the input current level is adequate to power the unit.

MICROPROCESSOR

The setting of the TIME DIAL, TIME CURVE selector switch, and circuit board jumpers provide the micro-processor with ten operating parameters for the desired response by the relay. The microprocessor performs the program operations based on the input current level and internal software program. When the Active/Pickup LED is green, the microprocessor is active and executing code.

FUNCTIONAL DESCRIPTION, continued

Operating power from the power supply is applied to the microprocessor supervisor circuit. When the input current falls below an acceptable level, the supervisor circuit interrupts the microprocessor and halts further operation.

The watchdog timer monitors the microprocessor for specific pulses indicating proper program operation. If something occurs to disrupt the microprocessor, these pulses stop, the watchdog timer times out and sends a reset pulse to the microprocessor. The microprocessor resets and resumes normal operation.

Table 1 - Current Sensing Capabilities

50/60 Hz System CT Secondary	Time Element Pickup Range	Time Element Max. Continuous Current	Time Element Max. Current For 1 Second	Instantaneous Pickup Range	Time Element Pickup Accuracy	Instantaneous Pickup Accuracy
5 Amp	0.5 to 15.9 Amps in 0.1 Amp Steps	14 Amps	400 Amps	1 to 99 Amps in 1 Amp Steps	2% from 0.5 to 15.9 Amps	2% from 1 to 99 Amps
1 Amp	0.1 to 3.18 Amps in .02 Amp Steps	2.8 Amps	80 Amps	0.2 to 19.8 Amps in 0.2 Amp Steps	2% from 0.1 to 3.18 Amps	2% from 0.2 to 19.8 Amps

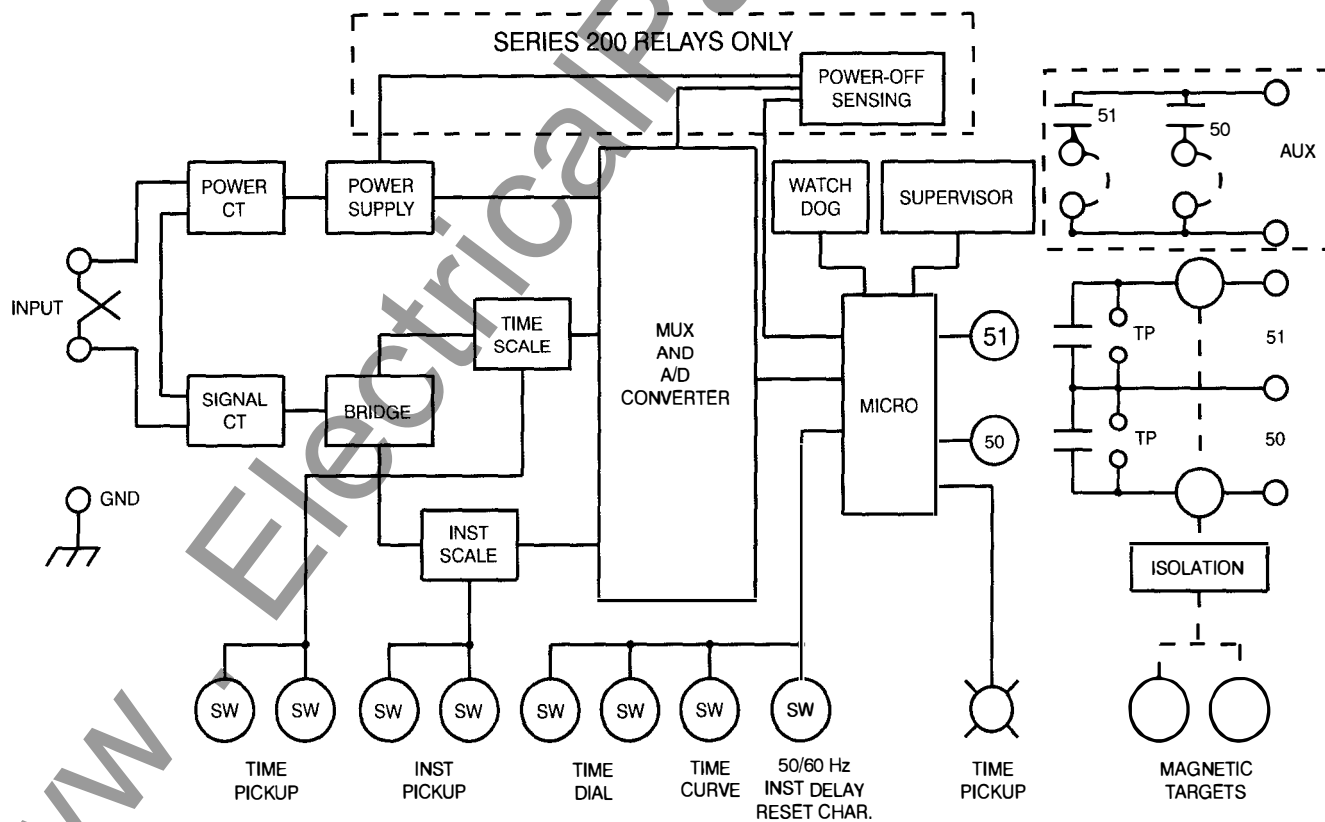

Figure 1 - Functional Block Diagram

FUNCTIONAL DESCRIPTION, continued

OUTPUTS

The TIME contacts (51 and 51AUX) are closed in accordance with conditions defined by the selected time characteristic equation and the sensed current magnitude. If the sensed current exceeds the INST PICKUP setting, the INST contacts (50) are closed.

Breakers controlled by the output contacts can be manually trip tested by inserting a jumper between the TIME and INST MANUAL TRIP test points on the front panel.

TIME ELEMENT CHARACTERISTIC SHAPES FOR CO and BS142 CURVES

All time characteristic curves follow the relation:

$$T_T = \frac{AD}{M^{N-C}} + BD + K = \text{Time to trip}$$

$$T_R = \frac{RD}{M^2-1} = \text{Time for decaying reset}$$

Table 2.

Curve Type			
Basler	Type	Similar To	
S1	Short Inverse	ABB CO-2	
S2	Short Inverse	GE IAC-55	200 series only
L1	Long Inverse	ABB CO-5	
L2	Long Inverse	GE IAC-66	200 series only
D1, D2	Definite Inverse	ABB CO-6	
M1, M2	Definite Inverse	ABB CO-7	
I1	Inverse	ABB CO-8	
I2	Inverse	GE IAC-51	200 series only
V1	Very Inverse	ABB CO-9	
V2	Very Inverse	GE IAC53	200 series only
E1	Extremely Inverse	ABB CO-11	
E2	Extremely Inverse	GE IAC 77	200 series only
B	British Standard Very Inverse	BS 142-B	
C	British Standard Extremely Inverse	BS 142-C	
F	Fixed Time	none	

Actual curve constants are available in the Instruction Manual. See page 1 of this bulletin for applicable publication number.

The Active/Pickup LED on the front panel will turn red when the applied current just exceeds the PICKUP setting.

RESET

Reset occurs when the current level is less than pickup. Internal switch provides selection of either an Instantaneous or a decaying reset characteristic.

The instantaneous reset characteristic forces the timer to zero when the input current falls below 95% of setting. This fast reset characteristic prevents the ratcheting effect on electro-mechanical relay disks that occurs for repeated faults.

The decaying reset characteristic replicates the decaying reset of electromechanical relay disks. Models with style numbers in the 200 series continue the decaying process even when the input current goes to zero. Models with style numbers in the 100 series reset immediately when the input current drops below the minimum required to power-up the relay (.5A for 5A models and 0.1A for 1A models).

TIME DIAL RANGE AND ACCURACY

The TIME DIAL range is 0.0 to 9.9 in 0.1 steps. A setting of 0.0 results in instantaneous operation without intentional time delay.

INSTANTANEOUS ELEMENT CHARACTERISTICS

The characteristic for phase faults is faster because the relay will be powered-up. However, the tripping characteristic for ground applications is slightly longer to allow time to power-up the relay. This longer trip time for ground applications is beneficial because it helps avoid nuisance trips. These timing characteristics are shown in Figure 3.

Additional definite time delays of 0.1, 0.2 or 0.3 seconds may be added to the instantaneous element on 100 series units; 200 series units have only 0.1 seconds. The definite delay is determined by switches on the circuit card.

OUTPUTS

Separate output contacts are provided for the TIME (51) and INST (50) trip functions. An additional auxiliary output relay (51 AUX) is included. This output operates simultaneously with the TIME output relay. All output contacts are configured normally open (NO).

MANUAL TRIP TESTING

The relay is provided with front panel test points to allow shorting the output terminals to verify external control circuit wiring.

TARGETS

Two target indicators are provided as a standard feature of the BE1-50/51B. These magnetically latched, current operated targets provide visual indication of trip by the TIME or INST output contact. These targets must be manually reset after the abnormal condition has been removed or corrected.

FUNCTIONAL DESCRIPTION, continued

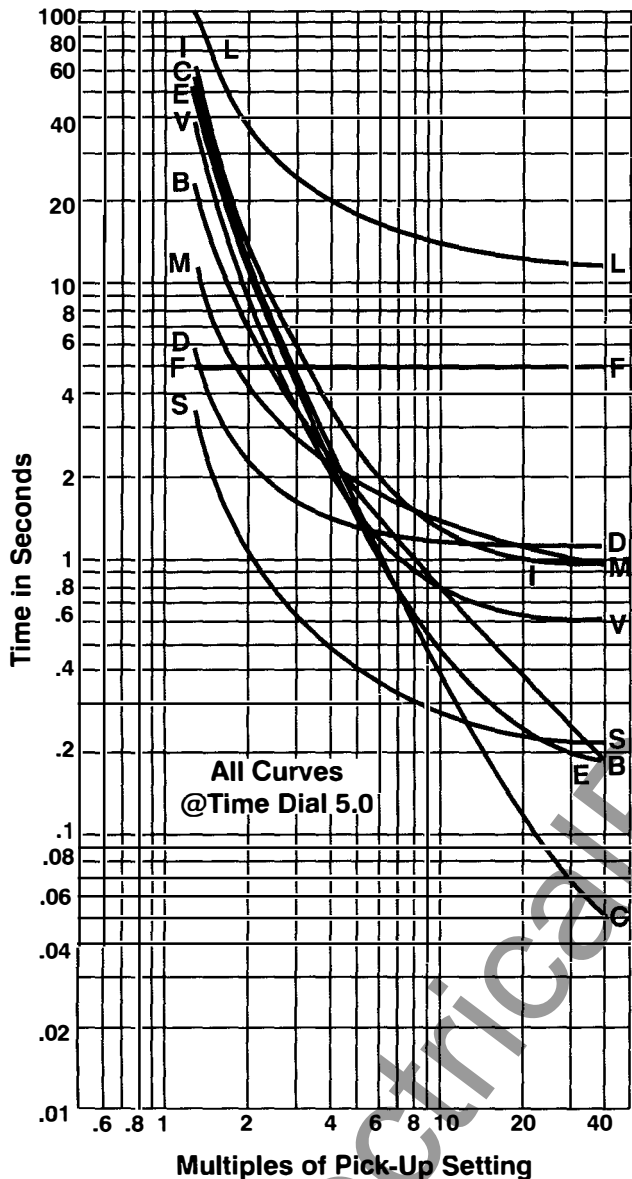

CO and BS142 curves in 100 and 200 series models:

- | | | |
|-----------------|----------------------|---------------------------|
| S=Short Inverse | M=Moderately Inverse | B=BS142 Very Inverse |
| L=Long Inverse | I=Inverse | C=BS142 Extremely Inverse |
| D=Definite Time | V=Very Inverse | F=Fixed Time |
| | E=Extremely Inverse | |

Figure 2 - Time-Current Characteristics

IAC curves in 200 series models only:

- Short Inverse
- Inverse
- Very Inverse
- Extremely Inverse
- Long Inverse

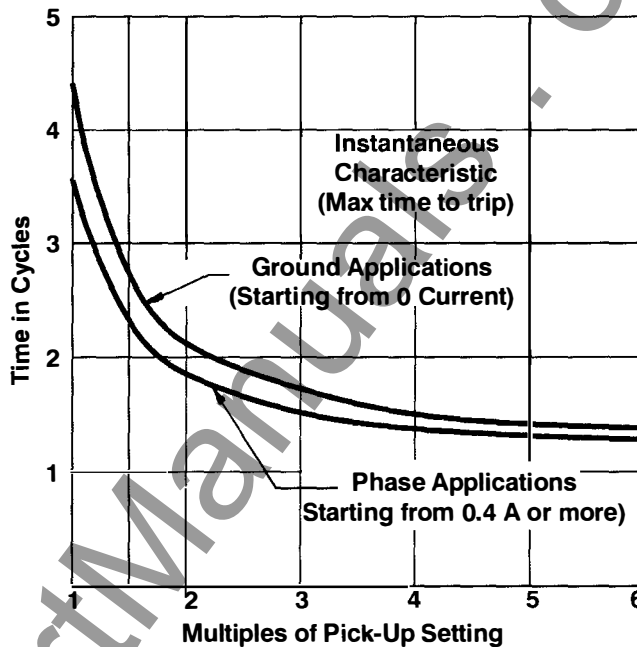

Figure 3 - Instantaneous Characteristics

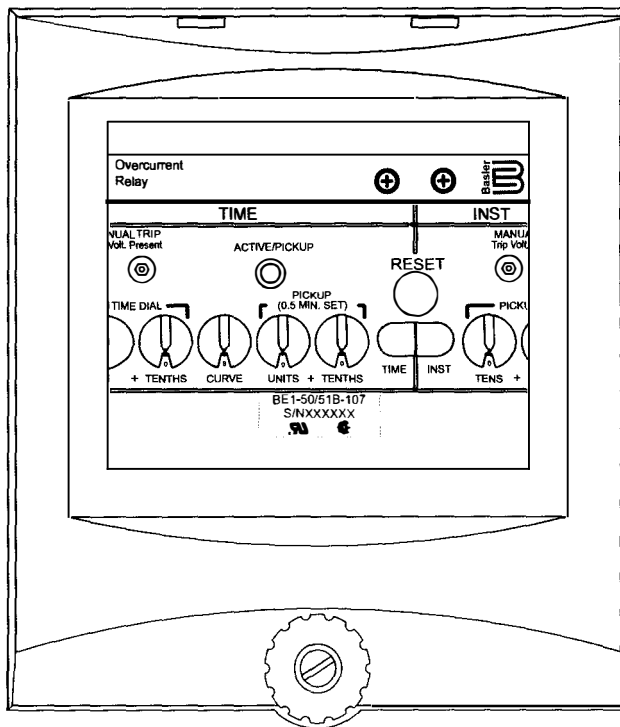

Figure 4 - Front Panel, S1 Case

SPECIFICATIONS

CURRENT SENSING INPUT:	Continuous Current	One Second Current
5 Amp Unit	14.0 Amps	400 Amps
1 Amp Unit	2.8 Amps	80 Amps

TIME PICKUP RANGE:

5 Amp Unit: 0.5 to 15.9 Amps in 0.1 Amp steps
1 Amp Unit: 0.1 to 3.18 Amps in 0.02 Amp steps

TIME DROPOUT:

Not less than 95% of pickup value.

TIME PICKUP ACCURACY:

± 2% of setting

TIME DIAL RANGE:

0.0 to 9.9 in 0.1 steps

TIME CHARACTERISTICS:

Nine inverse time and 1 fixed time function can be selected by a front panel switch. Characteristic curves are defined by the time characteristic equation. The fixed time characteristic provides delays of 0.0 to 9.9 seconds corresponding to the dial setting.

INVERSE TIMING ACCURACY:

± 2%, ±1 cycle for multiples of pickup from 2 to 40.
Below multiples of 2, errors may increase directly proportional to the value of $\frac{1}{(M^N-1)}$.

FIXED TIME ACCURACY:

±2% or 30 milliseconds, whichever is greater.

TIME RESET:

Instantaneous or decay, internally selectable.

INST PICKUP RANGE:

5 Amp Unit: 2.0 to 99 Amps in 1 Amp steps
1 Amp Unit: 0.2 to 19.8 Amps in 0.2 Amp steps

INST DROPOUT:

95% of pickup

INST PICKUP ACCURACY:

± 2% of setting

INST CHARACTERISTIC:

See Figure 3. Additional user selectable (by DIP switches) definite delays of 0.1, 0.2 and 0.3 seconds for -100 series; 0 and 0.1 for -200 series.

INST TRANSIENT RESPONSE:

Less than 10% overreach with system time constants up to 40 milliseconds.

BURDEN: Burden is non-linear and resistive.

5 Amp Unit: 4.8 Ohms @ 0.5A & 0.2 Ohms @ 5A
1 Amp Unit: 120 Ohms @ 0.1A & 5 Ohms @ 1A

TARGETS:

Magnetically latched, manually reset for TIME and INST output functions.

Operate Current: 0.2 Amp minimum

Coil Resistance: 0.1 Ohm

Operate Time: < 1 millisecond

OUTPUTS:

Resistive:

120/240 Vac: Make and carry 30 Amp for 0.2 sec., carry 7 Amp for 2 min., 3 Amp continuously, and break 5 Amp.

125/250 Vdc: Make and carry 30 Amp for 0.2 sec., carry 7 Amp for 2 min., 3 Amp continuously, and break 0.3 Amp.

Inductive:

120/240Vac, 125/250Vdc: Make and carry 30 Amp for 0.2 sec., carry 7 Amp for 2 min., 3 Amp continuously, and break 0.3 Amp. (L/R=0.04).

ISOLATION:

2000 Vac at 50/60 Hz for one minute (1500 Vac for one minute across open contacts) in accordance with IEC 255-5 and IEEE C37.90-1-1989 (Dielectric Test).

SURGE WITHSTAND CAPABILITY:

Qualified to IEEE C37.90.1-1989

FAST TRANSIENT:

Qualified to IEEE C37.90.1-1989

IMPULSE TEST:

Qualified to IEC 255-5

RADIO FREQUENCY INTERFERENCE (RFI):

Qualified to IEEE C37.90.2-1989. Field tested using five watt transceiver operating at random frequencies centered around 144 MHZ and 440 MHZ.

TEMPERATURE:

Operating Range -40° C (-40° F) to 70° C (158° F).
Recommended Storage Range -50° C (-58° F) to 70° C (158° F).

SHOCK:

15g in each of three mutually perpendicular planes.

VIBRATION:

2g in each of three mutually perpendicular planes swept over the range of 10 to 500 Hz for a total of 6 sweeps, 15 minutes per sweep.

SPECIFICATIONS, continued

AGENCY:

cURus recognition per UL Standard 508, File E97035
and CSA Standard C22.2 No. 14

CASE SIZE: A1 or S1

NET WEIGHT: 8.6 pounds

www.ElectricalPartManuals.com

ORDERING

MODEL NUMBER

BE1-50/51B Time Overcurrent Relay

HOW TO ORDER:

Designate the Model Number and the three-digit dash number from Table 3 to define the configuration desired.

Table 3.

NEW INSTALLATION PACKAGES	MODEL NUMBER
For 5 Amp System CT Secondaries Semi-Flush Mounting, A1 Size Case Drawout Construction, Testable-in-Case	BE1-50/51B-105 BE1-50/51B-205
Projection Mounting, S1 Size Case Drawout Construction, Testable-in-Case	BE1-50/51B-106 BE1-50/51B-206
Semi-Flush Mounting, S1 Size Case Drawout Construction, Testable-in-Case	BE1-50/51B-107 BE1-50/51B-207
For 1 Amp System CT Secondaries Semi-Flush Mounting, A1 Size Case Drawout Construction, Testable-in-Case	BE1-50/51B-101 BE1-50/51B-201
Projection Mounting, S1 Size Case Drawout Construction, Testable-in-Case	BE1-50/51B-102 BE1-50/51B-202
Semi-Flush Mounting, S1 Size Case Drawout Construction, Testable-in-Case	BE1-50/51B-103 BE1-50/51B-203

Model numbers ending in 200 series include memory to replicate the decaying reset characteristic of electro-mechanical relay disks even while the input current is zero. Model numbers ending in 100 series reset instantaneously (regardless of settings) when the input current drops below the minimum TOC pickup value.

NOTES

ORDERING INFORMATION

All units are self powered and supplied with 10 switch selectable curves, TIME and INST functions and outputs, magnetically latched targets, and an auxiliary output contact.

STANDARD ACCESSORIES:

A test plug is available to allow testing of the relay without removing external wiring.

Order test plug: Basler part number: 10095.



Highland, IL USA Taylor, TX USA
Moulonville, France Suzhou, China

P.A. E. Les Pins, 67319 Wasselonne Cedex FRANCE
Tel +33 3.88.87.1010 Fax +33 3.88.87.0808
e-mail: beifrance@basler.com

B Basler Electric

Route 143, Box 269, Highland, Illinois U.S.A. 62249
Tel +1 618.654.2341 Fax +1 618.654.2351
e-mail: info@basler.com

www.basler.com



No. 1300 North Zhongshan Road, Wujiang Economic Development Zone
Suzhou, Jiangsu Province - P.R. China 215200
Tel +86(0)512 6346 1730 Fax +86(0)512 6346 1760
e-mail: beichina@basler.com

Printed in U.S.A.