

BULLETIN 108

**INSTRUCTIONS for
GROUND FAULT SENSING EQUIPMENT**

CAT. NO. GFR-1, GROUND FAULT RELAY
WITHOUT INTERLOCK CIRCUIT

CAT. NO. GFR-2, GROUND FAULT RELAY
WITH INTERLOCK CIRCUIT

CAT. NO. GFS-__x__, GROUND FAULT SENSOR

boltswitch, inc.

6107 WEST LOU AVENUE
CRYSTAL LAKE, ILL. 60014
815 / 459-6900
TELEX 72-2489

GENERAL

The purpose of the Boltswitch Ground Fault Relay and Ground Fault Sensor is to sense failure to ground fault currents. When the magnitude of a fault current exceeds a preset level an output signal is provided by the Ground Fault Relay. The signal may be used directly to trip a Boltswitch Shunt Trip switch, initiate tripping of another type of disconnecting means, or for indicative purposes. Proper operation of this equipment is dependant on proper installation.

DESCRIPTION

The Ground Fault Relay is available in two forms: GFR-1 (without interlock circuit) and GFR-2 (with interlock circuit). Both feature adjustable trip current level and time delay settings, power indicator light, a trip indicator, a built-in test circuit, and shunt trip bypass to allow testing of the system without interruption of service. The optional test or indicator panel is required for testing on full operation of the system.

The Ground Fault Sensor is available in various sizes and has two sets of windings, one for normal operation and one for testing.

POWER

The power to operate the Ground Fault Relay is 120 Volts AC, applied across terminals 1 and 6. Terminal 2 must be grounded. A 75 VA control transformer with good regulation is required to operate this ground fault sensing equipment used in conjunction with a Boltswitch Shunt Trip switch. The recommended transformer is a line voltage of 200 or equivalent. Applications using other than a Boltswitch Shunt Trip switch require a larger control transformer.

INPUT SIGNAL

The input signal is obtained from a Boltswitch Ground Fault Sensor wired in accordance with the wiring diagram. The sensor must be grounded. See Figure 1. The Boltswitch Ground Fault Relay can be used with a Westinghouse sensor (Motor, Westinghouse calls their sensor a "monitor"), Westinghouse sensor windings use the same number of turns as the other sensor. See Figure 2. This combination is used by Underwriters Laboratories.

OUTPUT

The output is 120 volts, AC, between terminals 4 and 5. The maximum current rating is 10 amp, usually 3 amp control circuit.

EXTERNAL RESISTOR

An external resistor is provided in the test circuit. It should be installed per Figure 4 and wired per Figure 1.

RESET

To reset the Ground Fault Relay, move the lever on the front of the unit from the "Trip" to the "Normal" position.

SELECTIVITY

On distribution systems using more than one ground fault detection device, two methods of selective coordination are available. One method relies solely on trip current level and time delay settings. The other method involves zone selective interlocking.

The first method uses Ground Fault Relays without interlocking. The time delay and trip current settings should be carefully selected to assure that the device furthest downstream that senses the fault will trip first, thus allowing maximum continuity of service.

The second method uses Ground Fault Relays with interlocking. Zone selective interlocking also requires careful adjustment of time delay and trip current settings. However, the time delay only functions when a device downstream is also sensing the fault. Without receiving a signal from a downstream device, the Ground Fault Relay reacts immediately. This system allows the nearest device upstream of the fault to react as fast as possible no matter where the fault occurs, thus keeping damage to a minimum. If desired, an upstream device can be blocked from tripping when a downstream device senses a fault by using the no-trip input.

INTERLOCK WIRING (GFR-2 only)

The interlock wiring terminals are arranged as follows:

6. Common
7. Output
8. Input, timed trip
9. Input, no-trip

All wiring should be #14 or larger twisted pairs of wire with a maximum distance of 250 feet from the first device. The wires should run separate from main conductors or other wiring. For a typical wiring diagram see Figure 3. If some time delay is desired on the ground fault unit furthest downstream, a jumper should be placed between terminals 7 and 8 and the time delay adjusted accordingly.

TESTING

Upon installation of this equipment it shall be tested in accordance with the following instructions. These tests shall be conducted by qualified personnel only.

The proper location of the sensor around the circuit to be protected shall be determined. This can be done visually, with knowledge of which bus is involved. The grounding points of the system shall be verified to determine that ground paths do not exist that would bypass the sensor. The following is a recommended procedure:

1. Disconnect the power source.
 2. Disconnect the ground bus link.
 3. Using a "megger" type meter, measure the resistance to ground of each phase and neutral, if used. No reading of less than 100 ohms is acceptable. Readings of 1 megohm or more are preferable.
 - Note - High-voltage testers and resistance bridges may be used.
 4. Reconnect the ground bond link.
 5. Reconnect the power source.
- A simulated or controlled fault current is to be generated and the reaction of the circuit interrupting device observed for correct response.

TEST

1. Depress and hold the button marked "push to test" on the front of the Ground Fault Relay. The relay should trip instantly or after the preset time delay, dependant on the system.
 2. Release the button.
 3. The interrupting device should trip when the relay trips. Operation of the ground fault unit can be periodically tested without interrupting the service. To perform this test, the following procedure should be used:
 1. Depress and hold the button marked "shunt trip bypass" on the front of the relay.
 2. Depress the button marked "push to test" until the relay trips. Tripping should occur instantly or after the preset time delay, dependant on the systems.
 3. Reset the Ground Fault Relay.
 4. Release the "shunt trip bypass" button.
- All test results should be recorded on the provided form and retained by those in charge of the buildings electrical installation in order to be available to the authority having jurisdiction.

NOTE

Proper grounding of this equipment is essential. If the unit does not test properly, check to see that both the relay and the sensor are properly grounded.

BASIC WIRING DIAGRAM

Boilswitch GROUND FAULT RELAY
with *Boilswitch* SENSOR

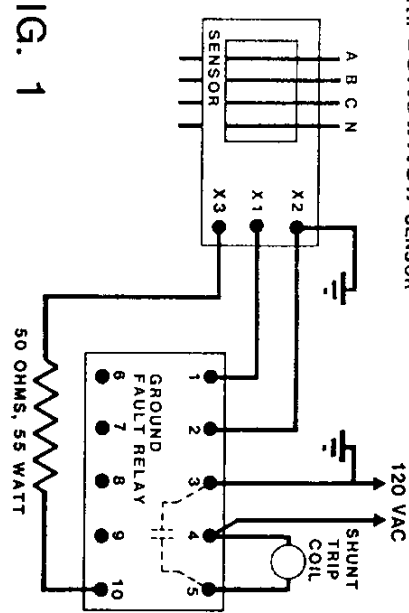
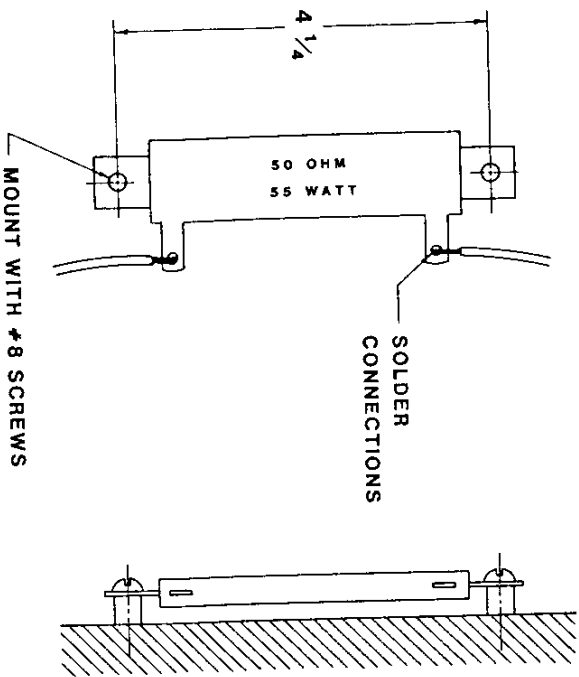

FIG. 1

INSTRUCTIONS

FOR MOUNTING RESISTOR SUPPLIED WITH
boitswitch® GROUND FAULT RELAY



NOTE: RESISTOR MAY BE MOUNTED IN ANY POSITION.
POTENTIAL ON TERMINALS IS 120 VOLTS TO
GROUND. CONTROL WIRING SHOULD NOT BE RUN
IN DIRECT CONTACT WITH RESISTOR. REFER TO
WIRING DIAGRAM ON SIDE OF RELAY.

FIG. 4