

Transformer Differential Relay

MD32T Transformer Differential Relay

The MD32T Transformer Differential Relay is a member of Cooper Power Systems' Edison® line of microprocessor based protective relays. The MD32T relay offers the following functions:

- High and low set differential elements for each phase with multi-slope bias characteristics. The MD32T is suitable for protecting any two winding transformer or a three winding transformer with unit-directional current flow.
- Low set differential element response time of less than 2 cycles, high set response time under 1 cycle.
- Programmable 2nd and 5th harmonic restraint elements which may be reduced automatically during transformer energization or at any time by an external trigger.
- Restricted ground fault element.
- Automatic CT ratio compensation for all transformer winding and CT connection configurations through programmable vector groups.
- 16 cycle oscillographic records of trip events. An oscillographic record may also be triggered externally.

The MD32T also shares the following features common to all Edison® relays:

- Simple five button man machine interface (MMI) allows access to all functions, settings, and stored data without the need for a computer.
- Bright electroluminescent display easily visible even in brightly lit environments.
- Draw-out design permits relay testing without disturbing connections to case.



Figure 1.
Front View of the MD32T Transformer Differential Relay

- Modbus communication protocol and RS485 terminal on rear.
- Modular design allows the draw-out module to be fitted to a variety of space saving cabinet styles.
- Three programmable Form C (SPDT) output contacts and one Form A/B contact.
- Pick-up (start-time) elements.
- Programmable reset characteristics.
- Dedicated power supply/relay fail output contacts.

Applications

The MD32T is ideally suited for the protection of any two winding transformer against two or three phase internal faults, inter-turn faults, and ground faults in transformers with low-impedance or solidly grounded neutrals.

The MD32T may also be used to protect multi-winding transformers where one winding always acts as the source winding, and the CTs of the other load windings are connected in an appropriate manner to represent the sum of the load currents.

For autotransformer-started motors, some differential protection schemes include the autotransformer in the zone of protection. In this case a rotating machine differential relay, such as the MD32G, is not suitable as the 2nd and 5th harmonic restraint functions common to transformer differential relays is required. For this application, the MD32T should be used.

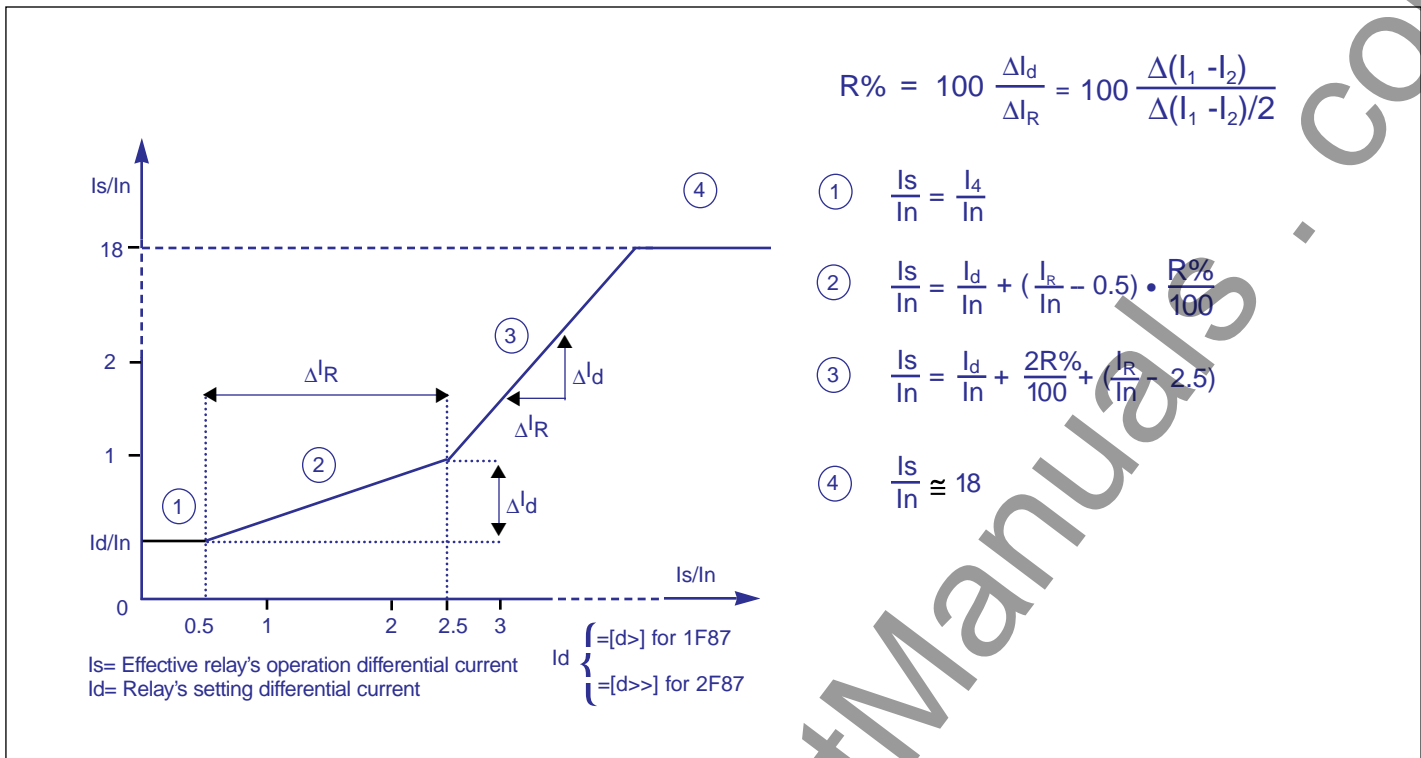

Figure 2.
Dual Slope Bias Characteristic of the MD32T Differential Relay

Multi-slope Biased Differential Element

Each phase is provided with its own differential element with a characteristic as shown in Figure 2. The relay internally calculates the RMS value of the differential current compensated for any CT ratio and phase angle mismatch.

The minimum differential current required for operation is adjustable between 0.1 and 0.5 pu of the rated current. This setting is fixed up to 0.5 pu of the transformers rated current. Above 0.5 pu compensation of the set point is required for CT saturation, which may occur at higher current levels, and for voltage ratio fluctuations caused by on-load tap changers. From 0.5 to 2.5 pu of rated current, the slope of the differential element is adjustable between 10 and 50%. Between 2.5 pu and 18 pu of rated current, the bias slope is fixed at 100%.

Low Set Differential Element

In addition to the multi-slope bias characteristic, the low set differential element is further equipped with programmable 2nd and 5th harmonic restraint logic.

During transformer energization, significant 2nd harmonic current is present, which may result in false trips. This requires the relay to suppress its response to the 2nd harmonic component of current. The MD32T allows for adjustment of the 2nd harmonic restraint element over the range of 0.1 to 0.3 pu of the transformer's rated current.

Similarly, over-excitation of the transformer may result in significant levels of 5th harmonic current, requiring similar restraint characteristics. The MD32T allows for an adjustment range of 0.2 - 0.4 pu of rated current. Either or both the 2nd and 5th harmonic restraint elements may be disabled if desired.

To avoid problems associated with the harmonic restraint elements from being too sensitive on actual

faults and blocking the relay, the MD32T allows the harmonic restraint settings to be lowered to as little as one-half the normal settings during a programmable time period following transformer energization. Transformer energization is sensed via a digital input connected to an auxiliary contact on the transformer's breaker.

High Set Differential

An instantaneous (high set) differential element is provided to quickly remove the transformer from service in the event of severe internal faults. To effectively eliminate the effects of dc offsets and harmonics, the relay trips on the sensing of sequential positive and negative peak currents whose magnitude exceeds the high set trip level.

The high set trip level may be either set to be a fixed value, or may be biased in the same fashion as the low set element. Due to the operational nature of the element, no harmonic programmable harmonic restraint elements are provided. This element will operate in less than 1 cycle (15 msec).

Ground Fault Protection

To provide greater coverage for ground faults, the MD32T monitors the fundamental frequency component of current fed into the ground element inputs. Depending upon the connection, this element can perform:

- Restricted ground fault protection for one Y connected winding (87N).
- Residual current (3I₀) protection of one winding (51G).
- Neutral current protection of one winding (51N).

This ground fault element consists of a definite time high set element and a fixed 30 ms response time instantaneous element. This element may be blocked during transformer energization.

Targets

Eight bright LED targets are provided as follows:

- One red LED for each of the three phase differential elements.
- One red LED for the restricted ground fault element.
- Two red LEDs to signal when the 2nd or 5th harmonic currents respectively exceed the restraint level.

For all of the above, the LEDs flash when the element is picked up, and constantly illuminate upon trip. In addition, one yellow LED is provided which illuminates when the blocking input is active. A second yellow LED flashes when the relay is in programming mode, and illuminates constantly upon relay or power supply failure.

Blocking Input

An opto-isolated programmable blocking input is provided. This input may be programmed so that when activated, any combination of the low set differential, high set differential, or ground fault elements may be blocked.

While the blocking input is active, the pickup of any element associated with the blocking input is prevented. Sensing of the input

quantities and the countdown of any timers begins only when the blocking is removed.

Reset Characteristic

The programmable output relays may be programmed to reset in one of two manners.

- Instantaneously upon the input or calculated quantities dropping below the pickup value.
- Manual reset (by front panel or computer command) only.

Measurements and Inrush Values

The following quantities are continuously monitored and are available for display at the relay and are accessible by software:

- RMS values of each phase's differential current
- Fundamental frequency component of the neutral current in per unit of the rated phase current.
- RMS values of the three high side currents.
- RMS values of the three low side currents.
- 2nd and 5th harmonic current components of each of the phase's differential currents.

In addition, the maximum values of each of these quantities during the first 100 msec after transformer energization is also recorded. This makes it convenient to quickly review the inrush currents associated with the most recent energization.

Last Trip Record

The following parameters are stored in non-volatile memory, providing details of the last five trip events:

- Which element was the cause of the last trip.
- The values of all measured currents at the time of trip.

In addition the relays keep a cumulative total of the cause of all breaker trips.

Oscillography

The MD32T stores two oscillographic records which are made available for downloading to a PC for graphing. All six input phase currents are recorded. Each oscillographic record consists of 8 pre-trigger and 8-post trigger cycles, for a total of 16 cycles. The waveform is sampled at 12 samples per cycle. Storage of an oscillographic record may be programmed to occur automatically every time a protective element trips, or to occur only upon an external trigger.

Output Elements

The following functions may be programmed to one or more of the output relays. The only limitation is that pick-up and time delay functions may not be assigned to operate the same output relay(s).

- Low set differential element.
- High set differential element.
- Instantaneous ground fault element.
- Time delayed ground fault element.

Diagnostics

Complete memory and circuit diagnostics are run upon powering the relay. The revision level of the firmware is displayed at this time.

The relay runs a comprehensive set of diagnostics every 15 minutes that includes memory checksum, test of the A/D converters by injection of an internally generated reference voltage, and a check of the ALU.

The relay provides two manual test routines which may be run at any time. The first routine performs the same 15 minute test and in addition checks the target LEDs and the control circuitry to the output relays without operating the output relays. The second test is identical but also operates the output relays.

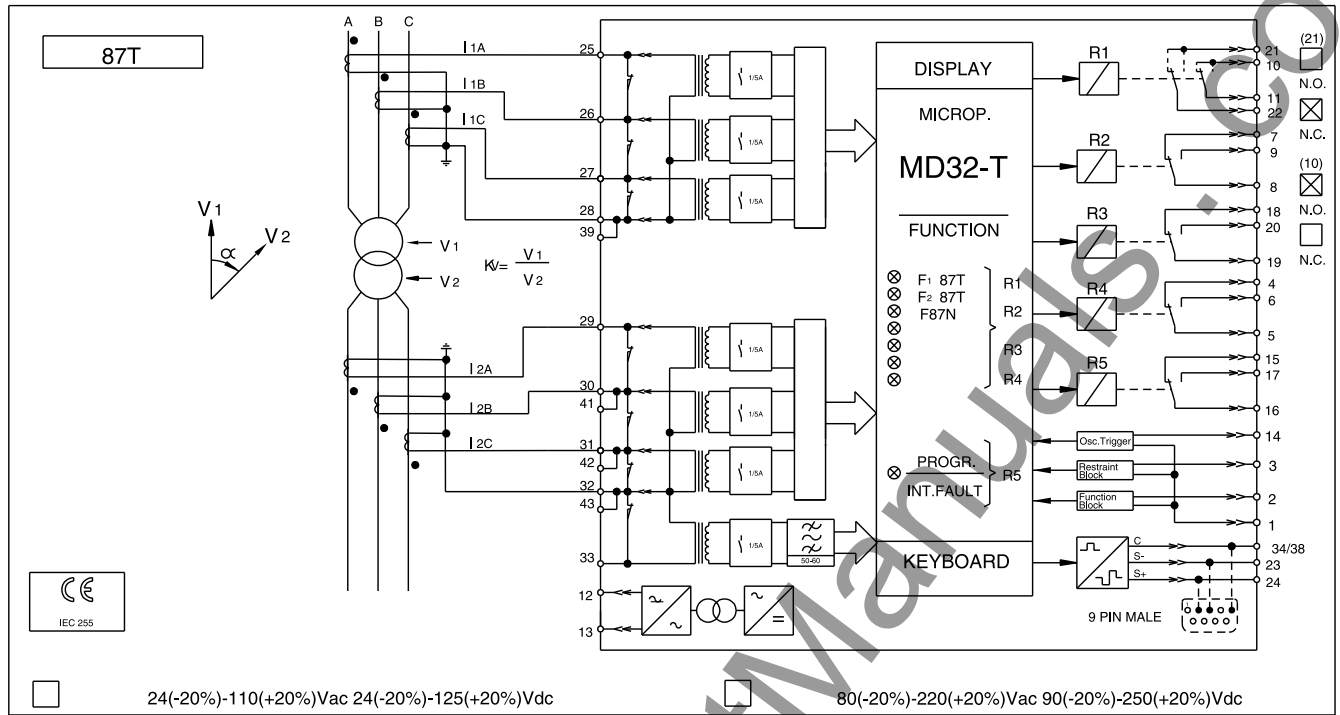

Figure 3.
Wiring Diagram for the MD32T Transformer Differential Relay used for the 87T Protection Only

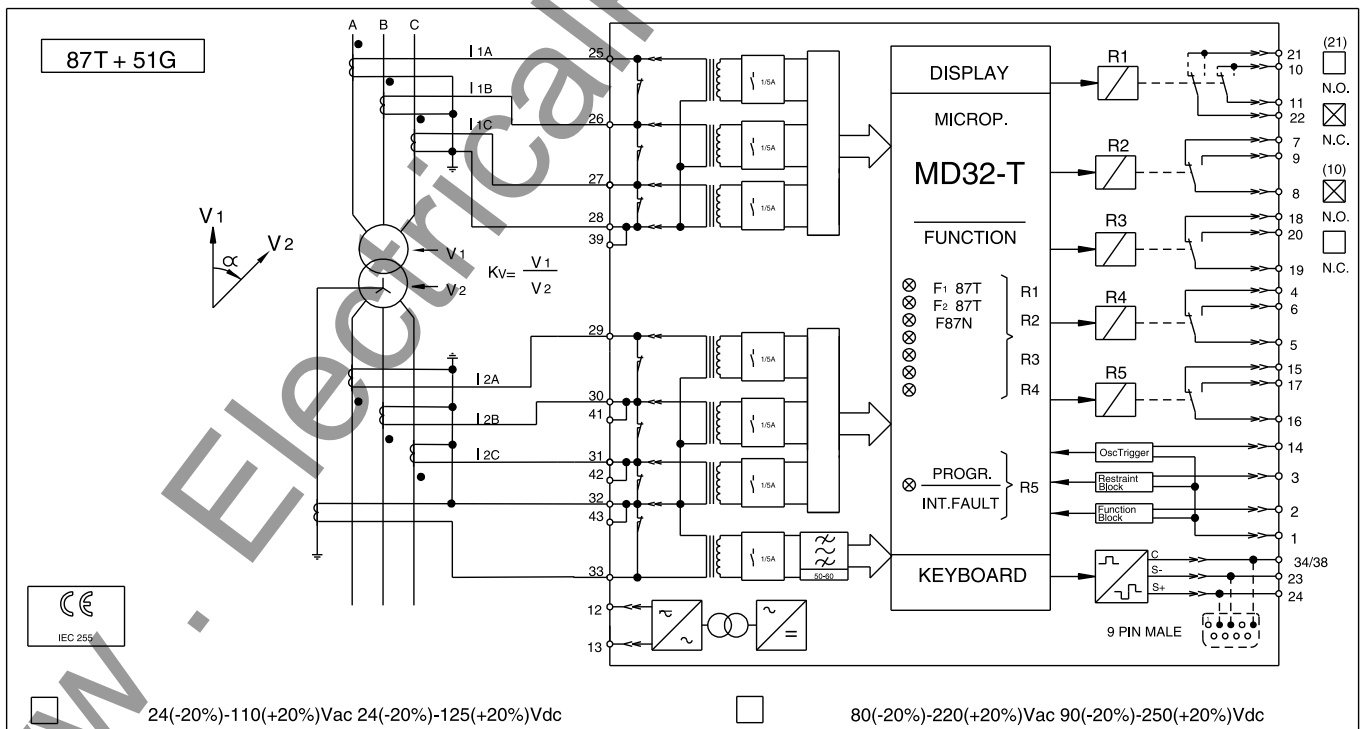

Figure 4.
Wiring Diagram for the MD32T Transformer Differential Relay used for 87T and 51G Protection

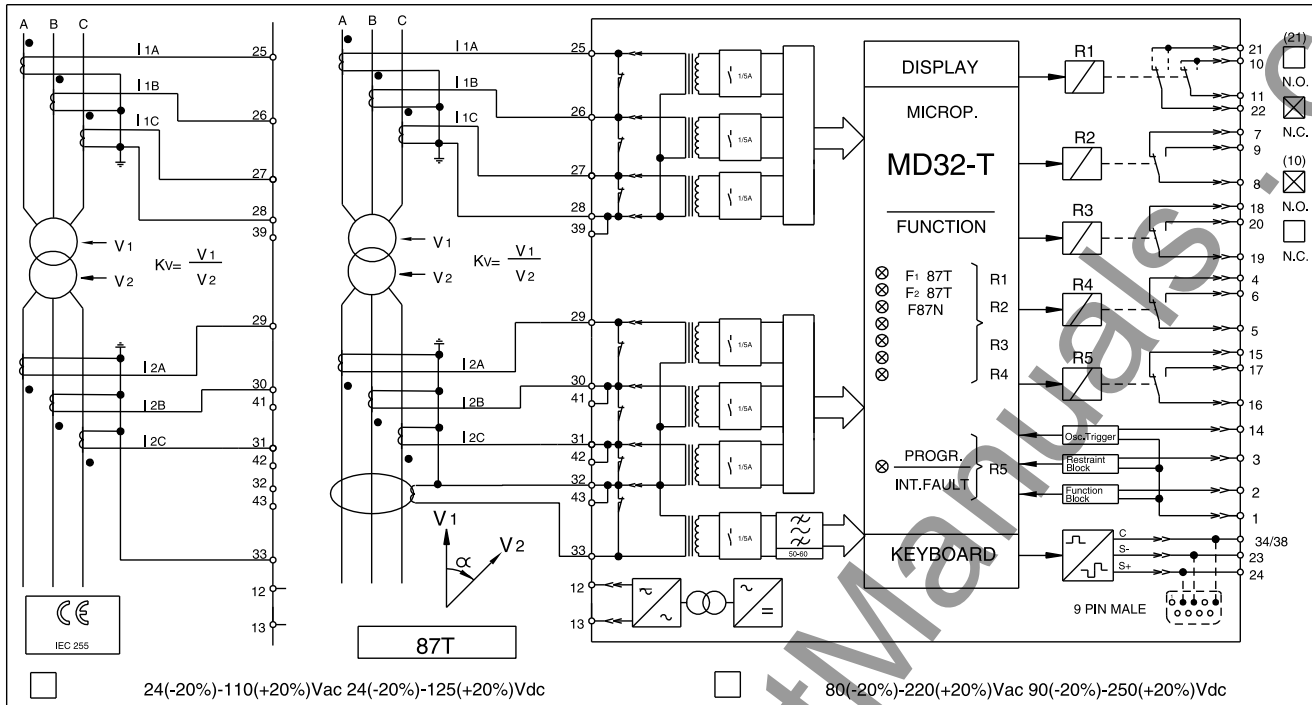

Figure 5. Wiring Diagram for the MD32T transformer Differential Relay used for 87T and 51N (Restricted Ground (Earth) Fault) Protection

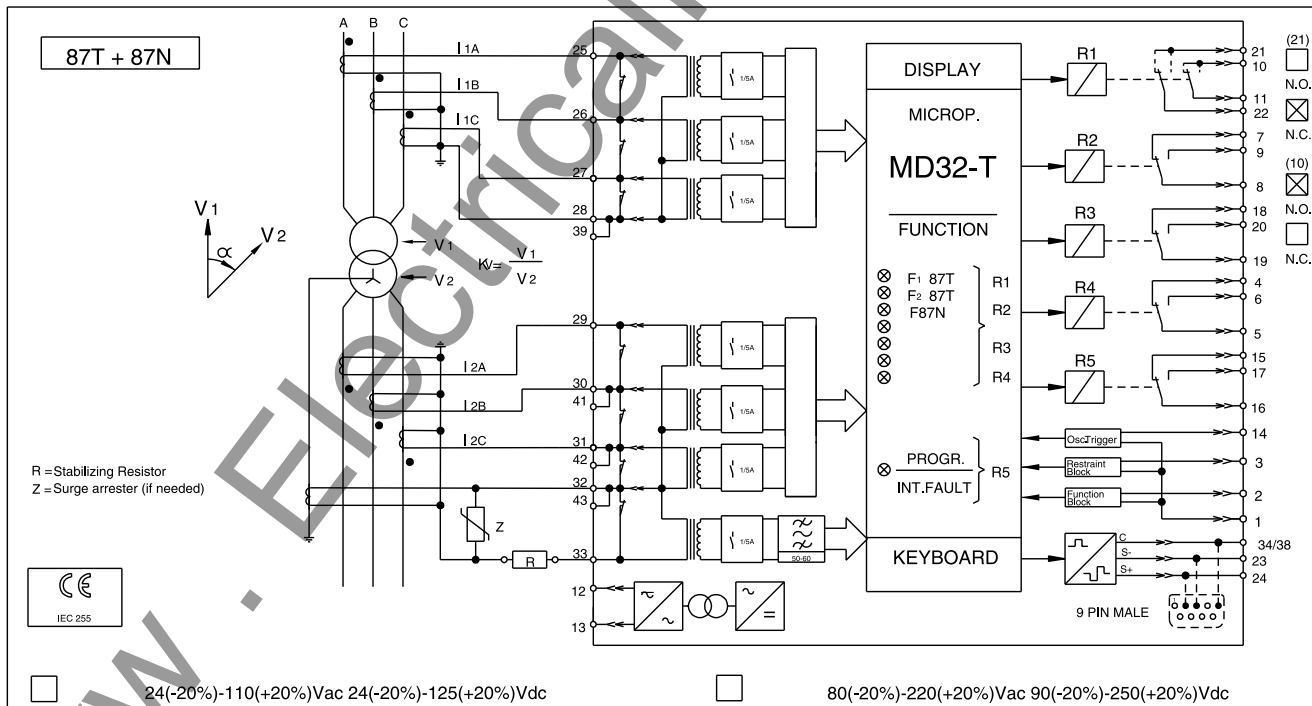

Figure 6. Wiring Diagram for the MD32T Transformer Differential Relay used for 87T and 87N (Restricted Ground (Earth) Fault) Protection

TABLE 1
Functional Specifications

Nominal system frequency setting range.....	50 or 60 Hz
Programmable rated primary input current of phase CTs.....	1 - 9999A in 1A steps(High and low side CT programmable separately)
Programmable rated phase-to-phase voltage of transformer	0.20 to 380.00 kV in 0.01 kV steps (High and low side voltages programmable separately)
Transformer connection and vector group.....	Yy0 to Yz0
Differential Element	
Minimum pick-up level of low set differential element	0.10 to 0.50 pu of rated CT current in 0.01 pu step
Minimum pick-up level of high set differential element.....	2.0 to 18.0 pu of rated CT current in 0.1 pu steps
Bias percentage slope from 0.5 pu to 2.5 pu rated CT current.....	10 - 50% in 1% steps
2nd Harmonic restraint level.....	0.10 to 0.30 pu of the differential current in 0.01 pu steps
5th Harmonic restraint level.....	0.20 to 0.40 pu of the differential current in 0.01 pu steps
Harmonic restraint multiplier (reduction)	0.50 to 1.00 pu of original setting in 0.01 pu steps during energization (2nd and 5th harmonic restraint multipliers programmable separately)
Harmonic restraint reduction timer (starting at transformer energization)	0.05 to 99.00 seconds in 0.01 sec. steps
Ground Fault Element	
Minimum pick-up level for ground fault element	0.01 to 1.00 pu of rated CT current in 0.01 pu steps
Time delay of ground fault element.....	0.02 to 9.99 seconds in 0.01 second steps as described in IEC 76

Dimensional and Electrical Specifications

See Catalog Section 150-05 for electrical specifications and dimensional information on all Edison® Relays.

Ordering Information

Construct catalog number from Table 2.

Example: MD32TL5JS is an MD32T with low range power supply, 5A CT inputs, in a single relay case.

If ordering two or more relays to be fit in a common case, the first relay ordered should indicate the case style desired. This relay will be located in the leftmost bay of the case. Subsequent relays should use the C2, C3, or C4 suffixes to denote their position in the case using the leftmost bay as a C1 reference.

TABLE 2
Catalog Numbers

Description	Catalog Number
Base Relay	MD32T
To the above add one each of the following applicable suffixes	
Power Supply¹	
24-110V AC/DC	L
90-220V AC/DC	H
Rated CT Input	
1A	1
5A	5
Modbus Protocol	J
Case Style²	
Draw out relay only, no cabinet supplied	D
Single relay case	S
Double relay case	T
19" Rack mount cabinet	N
Mounting Position	
Denotes mounting position in either a double case or 19" Rack along with other relays ordered at the same time.	C2 C3 C4

¹ The power supplies are user replaceable and interchangeable. See Catalog section 150-99.

² The relay itself may be drawn out of any of the listed cases and plugged into any of the other case styles. The catalog number specified during ordering denotes the type of cabinet in which the relay will be shipped.

