



Figure 1: Edison Idea Relay

The iCP-191 fuseless capacitor bank protection relay is a member of Cooper Power Systems' Edison[®] Idea[™] line of protective relays. The iCP-191 is a full-featured relay suitable for multi-string, fuseless, grounded shunt capacitor or filter bank protection and control applications. The relay calculates the apparent impedance of each string and determines capacitor unit failure when the impedance changes beyond a threshold. Protection on a per-string basis permits enhanced sensitivity and rapid identification of capacitor problems to the effected string. Protection on a per-string basis permits greater bank availability: set protective levels relative to actual string capacitor overvoltages instead of cumulative effects measured at the neutral, or internal tap, due to capacitor shorted sections distributed over several strings. The bank remains in service with multiple shorted series sections in various strings until the capacitor unit overvoltage is exceeded. This greater Mvar availability could be critical during a system-wide disturbance. The iCP-191 also provides advanced power quality, metering, communication and PLC functions.

The iCP-191 uses Cooper Power Systems' ProView[™] interface software package for PCs running the Microsoft[®] Windows[®] operating system. Via the *IDEA Workbench[™]* feature of ProView, add additional functionality to the iCP-191 by means of downloadable Custom Modules obtained from Cooper Power Systems. Provide custom solutions by employing the Workbench's intuitive and graphical tools for creating, viewing and testing logic diagrams. This expandability provides a continuous upgrade path that not only protects the initial investment in the relay but also provides a means to increase the relay's functionality in response to changing protection requirements and regulatory, power quality and reliability concerns.

PROTECTION AND CONTROL FUNCTIONS

- Unbalance detection of grounded, multi-string, fuseless shunt capacitor or filter banks using temperature-compensated apparent impedance (21C) (patent applied for).
- Low and High level, definite-time per string overcurrent (50L, 50H).
- Per phase rms, inverse time overcurrent (51).
- Definite time overvoltage alarming and inverse time overvoltage protection (51V).
- Definite time undervoltage (27).
- Dead Bus Trip (DBT).
- Block of Close while awaiting capacitor discharge.
- Fuse Fail (Loss of Voltage) detection (27FF).

ADVANCED CAPABILITIES

- Add new functions and features using *IDEA Workbench[™]* Custom Modules.
- Virtual Test Set[™]: Pre-test relay protective responses and custom logic interaction using the powerful simulation module built into the ProView software.
- Relay Replay[™]: Anticipate future changes to the protection environment based on historical oscillographic event data.
- Metering of Amps, Volts, Vars, etc: Accurately quantify system and bank health via important analog data.
- Sequence of Events: Quickly access logged relay responses to system or human activity via the front panel display or uploaded files.
- Data Profiler: Time-trend harmonic levels in and around the bank. Tailor the Profiler to trend the data important to you.
- ProView's relay scheme file completely documents protection and control algorithms via interactive logic diagrams; these are color-coded and come alive when viewing historical, on-line, or simulated data.
- Dual ports Ethernet: Easily integrate the relay into your communication network.

CUSTOMIZE THE iCP-191 WITH THE *IDEA WORKBENCH*™

The iCP-191 is a fully functional relay, ready to use right out of the box. However, there are applications where custom control logic, or custom functions need to be added to the relay. The *IDEA Workbench* is a revolutionary graphical software-programming environment provided by ProView that permits the user to customize the iCP-191.

- Add new features or protective functions by means of *IDEA Workbench* Custom Modules. Through these, your investment in the relay is protected as future needs and developments are addressed.
- Create custom control and protection logic using over 400 programming signals and tools, all selectable from drag-off Toolboxes. Logic created using these tools can then be saved as Custom Modules to be reused or shared with associates.

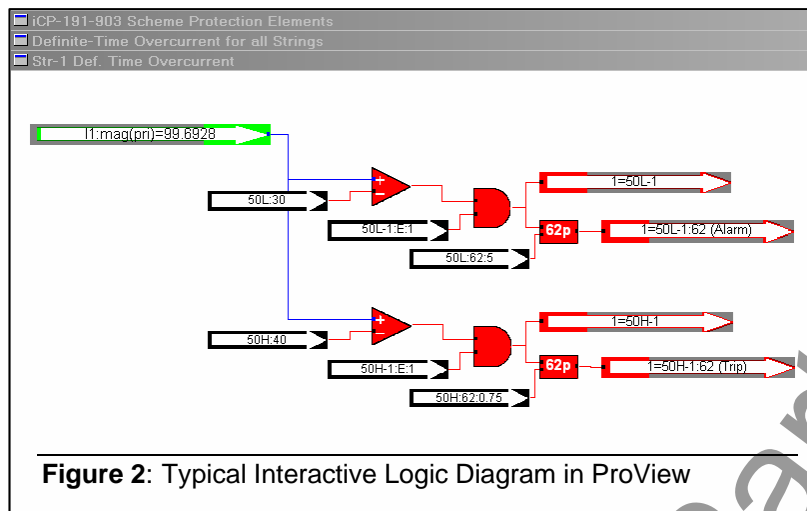

Figure 2: Typical Interactive Logic Diagram in ProView

- Monitor and control practically every aspect of the relay's operation with interactive logic diagrams. See Figure 2. View the layout of protection and control logic diagrams via the graphical interface software; observe actual binary status or analog data values while "On Line", playing back events or in simulation mode.
- Create custom metering and measurement quantities and application-specific sequence of event records and data profiling.
- Configure communication protocols. Alter protocol type, ports, data rates and input / output mapping to match the needs of the application.

Use the *IDEA Workbench* to rapidly and accurately create customized solutions by working the way the engineer thinks, via logic diagram and flowchart construction methods in a graphical environment. No equation-based or command-based logic programming is required.

MODULAR PER-PHASE APPLICATION

Apply the iCP-191 relay to protect up to 9 fuseless capacitor strings within a single phase. For more than 9 strings per phase, employ a second relay for that phase. (The second relay may be applied if no, or only a negligibly small, inrush reactor is used.) Use additional relays for other phases.

CAPACITOR BANK UNBALANCE PROTECTION USING PER-STRING IMPEDANCE (21C)

Designed for multi-string, fuseless, grounded banks, the 21C elements monitor bus voltage and string currents to determine when changes in apparent impedance are indicative of an internal unbalance within the bank. Currents in each string are monitored with lower-cost, low-BIL current transformers mounted near the neutral connection. Multiple levels of unbalance alarm and trip protection are provided per string. To improve sensitivity, the nominal string impedance is updated via real-time measurements at commissioning time to compensate for capacitor tolerances and to remove slight errors from the voltage and current transducers and the relays' impedance measurement.

Changes in ambient temperature also result in impedance variations as measured by the relay. To prevent false declaration of alarm or trip conditions, the iCP-191 relay employs a temperature compensation algorithm to remove the influence of ambient temperature upon the impedance measurement (patent applied for).

	ALARM TRIP	
STR1	●	●
STR2	⊗	●
STR3	⊗	●
STR4	●	●
STR5	●	●
STR6	●	●
STR7	●	●
STR8	●	●
STR9	⊗	⊗

OVERCURRENT, OVERLOAD PROTECTION

The iCP-191 offers a definite-time overcurrent alarm and protection element for each string thus providing reliable backup protection for the 21C elements. An inverse-time overcurrent element, following IEEE, IEC or industry-standard curves, protects the entire phase. The inverse time phase element uses true rms current to aid in harmonic overload protection of any inrush or filter reactors connected.

UNDER, OVERVOLTAGE PROTECTION

Calculated phase-neutral capacitor voltage is the input to the inverse time overvoltage element. The relay adjusts for any voltage drop across an inrush or filter reactor. The protection response characteristic is a piece-wise linear curve based on the IEEE STD-18 overvoltage / time point pairs. The rated voltage of the capacitor bank is the only setting for this simple but effective protective element. The iCP-191 also provides definite-time overvoltage alarming and undervoltage trip protection.

DEAD BUS TRIP (DBT)

If the capacitor bus becomes inadvertently de-energized, e.g., due to tripping of line breakers in response to a system fault, the DBT element may trip off the capacitor bank prior to any auto-reclosing. This prevents the occurrence of damaging electrical transients associated with re-energizing capacitor banks still containing trapped charge.

BLOCK OF CLOSE

Re-energization of capacitor banks with trapped charge causes transient overvoltages. The iCP-191 has logic implemented with user-settable time delays to allow decay of the trapped charge.

METERING

The iCP-191 offers extensive and high accuracy metering capabilities, including:

- Instantaneous Volt, Amp, Watt, vars and other quantities in primary scaled values.
- Demand metering with date/time stamped peak values.
- Harmonics metering (through the 15th) including THD for all voltage and all current channels.

EVENT RECORDS AND ANALYSIS TOOLS

The iCP-191 shares the same event recording and analysis tools as all Edison Idea relays. The Edison Idea allows for the display of event records in a variety of formats including waveforms (oscillography), magnitude plots, phasor diagrams, symmetrical component diagrams and more. Many of these event views are also available in On-Line View

mode where it is possible to monitor the status of the relay in real-time. Convert event data to COMTRADE files if needed for subsequent analysis

Relay Replay™

To evaluate the effect different settings would have on the relay, the Relay-Replay feature of the Edison Idea's ProView software allows the user to make any number of setting changes and replay an existing event using these new settings without the need for an actual relay or expensive test equipment. The operation of every aspect of the relay's performance can be observed: which elements pick-up what is the response time of those elements that do. This tool provides unprecedented "what-if" analysis capabilities.

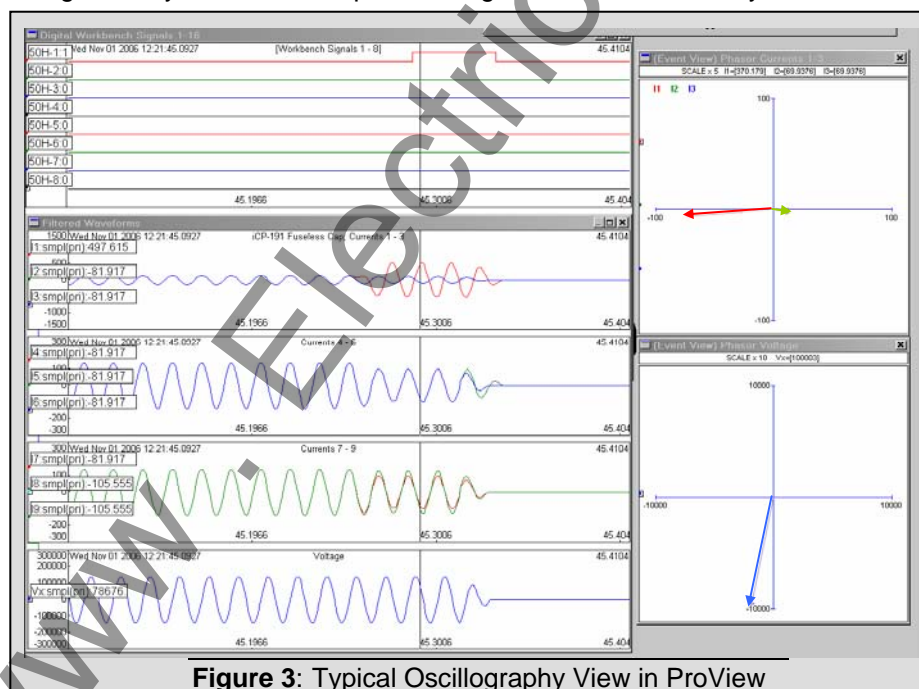

Figure 3: Typical Oscillography View in ProView

IDEA iCP-191 Capacitor Bank Protection Relay

COMMUNICATIONS

Modbus RTU and DNP 3.0 (serial or TCP/IP) communication protocols are available. Customize communication maps, add or delete information, add control points, and even create new signals to be brought out through communications via various serial or Ethernet ports. See Table 1 – Ordering Options for details on available communication options.

HARDWARE DIMENSIONS

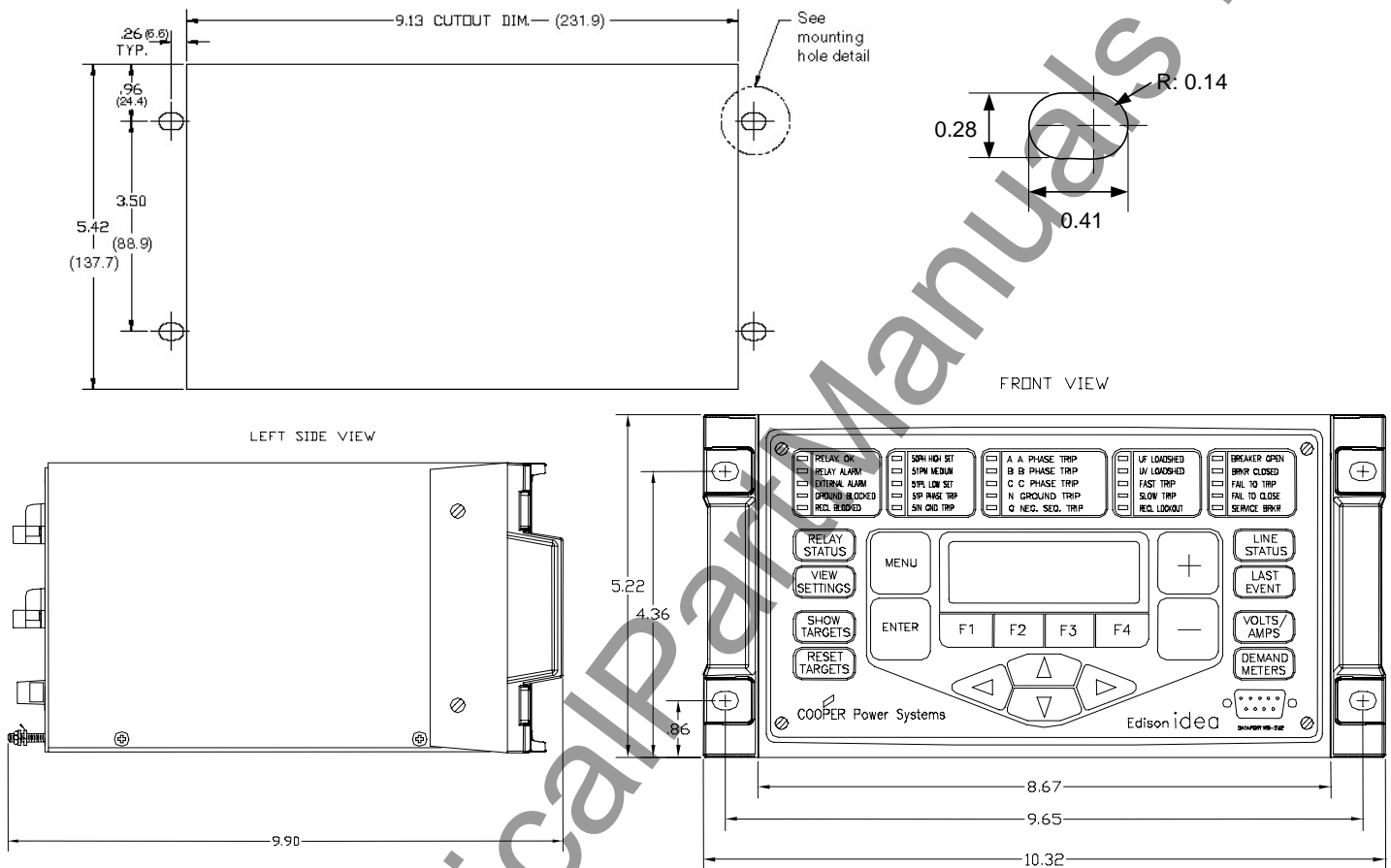

Figure 4: Edison Idea Relay Panel Cutout and Outline Dimensions in Inches (mm)

TYPICAL DC WIRING DIAGRAM

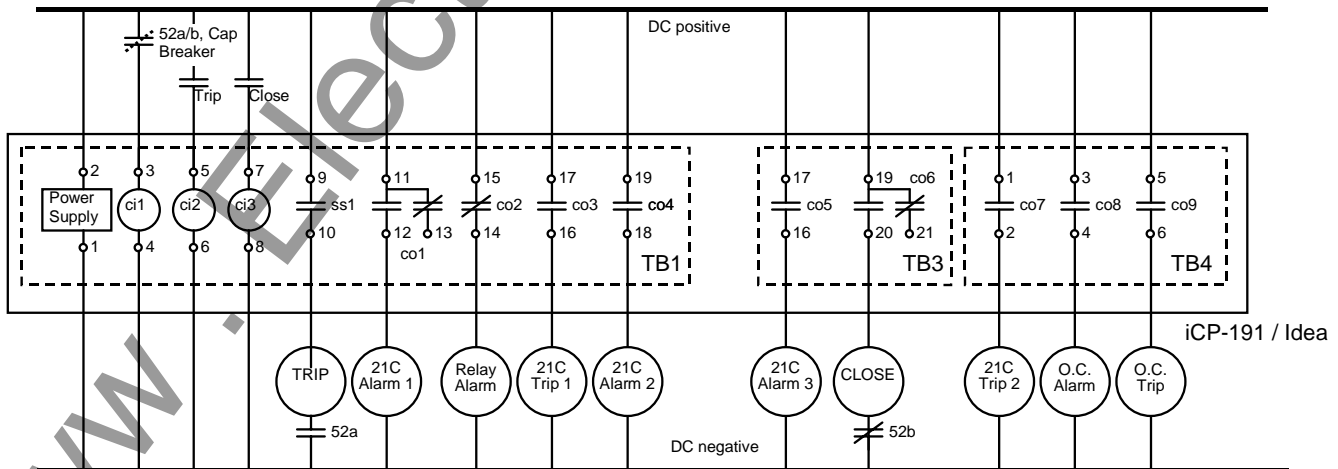

Figure 5: iCP-191 DC Wiring Diagram

TYPICAL AC WIRING DIAGRAM

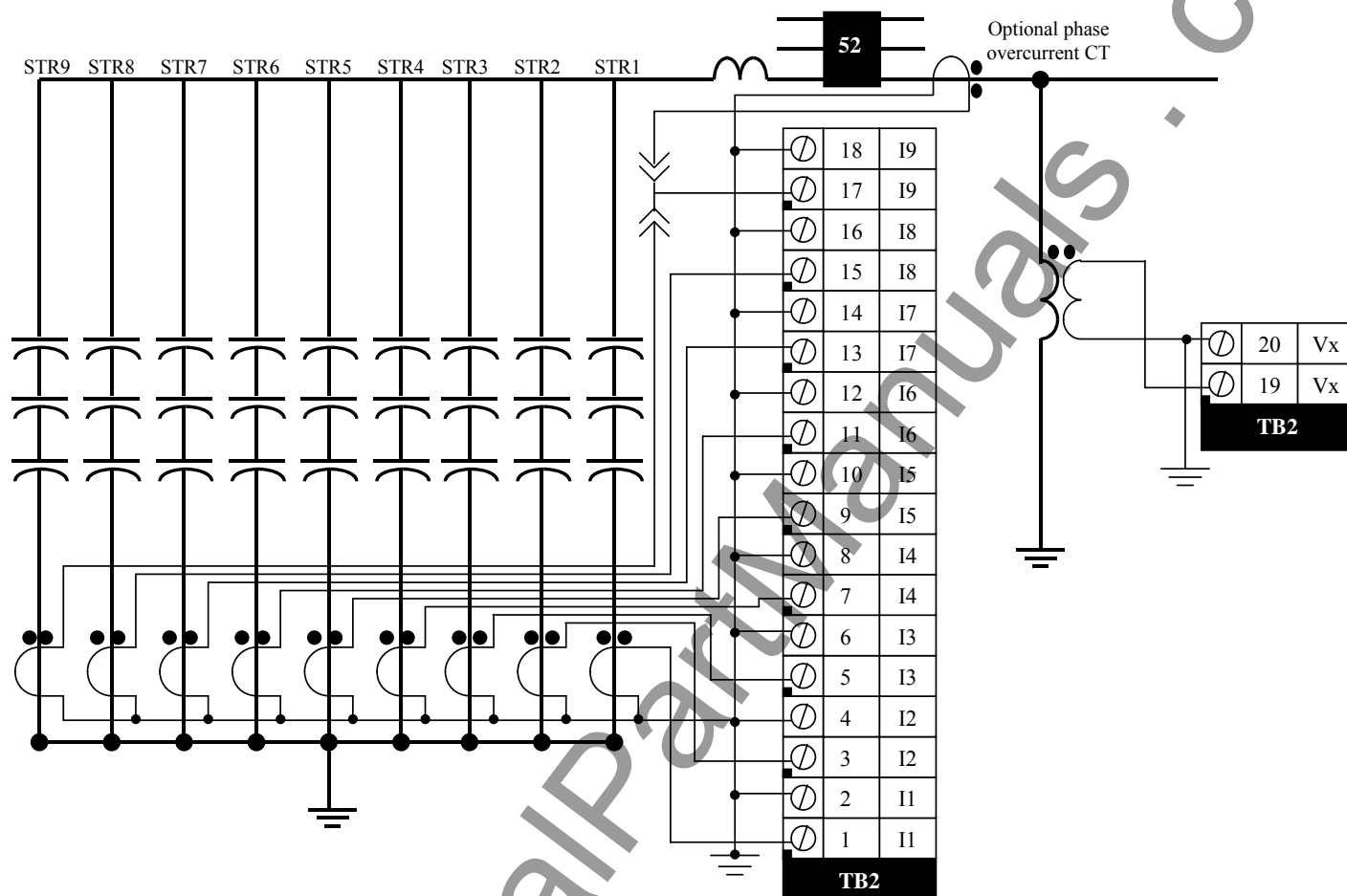

Figure 6: iCP-191 AC Wiring Diagram

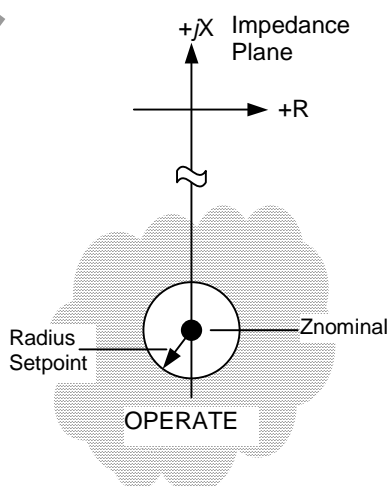

Figure 7: iCP-191 Impedance Response Characteristic

IDEA iCP-191 Capacitor Bank Protection Relay

Table 1 – Ordering Options

		A	B	C	D	E	F	G	H	I	
		Idea									
Construct Catalog Number from this table.		Product	Enclosure	Scheme	Language	Power	Input Range	CommOption	Aux I/O	TermBik	
		PR6	D2	C19							
Sample Catalog Number:		PR6	D2	C19	E	1	5	1	0	S	
<i>TYPE</i>	Edison Idea/IdeaPlus Relay Edison Idea Chassis	PR6									
<i>Scheme/</i>	ICP-191-903 impedance-based cap bank scheme		D2								
<i>Inserts</i>	English			C19							
<i>Language</i>	Portuguese Spanish Other				E P S O						
<i>Power</i>	48VDC Power Supply 125VDC/120VAC Power Supply 250VDC/240VAC Power Supply 24VDC Power Supply					4 1 2 3					
<i>Input Ranges</i>	5 Amp CT Inputs, 67/120V PT Inputs 1 Amp CT Inputs, 67/120V PT Inputs						5 1				
<i>Comm. Options</i>	RS485 Fiber serial Ethernet Fiber Optic:Fiber Optic MTRJ/MTRJ Ethernet Fiber Optic:Wire MTRJ/RJ45 Ethernet Wire:Wire RJ45/RJ45 Standard: None Ethernet Single Mode Fiber LC/LC							1 3 4 5 6 7 8			
<i>Aux I/O</i>	Select 8 Contact Inputs and 8 Contact Outputs, all N.O Select 8 Contact Inputs and 8 Contact Outputs, 1 NC, 7NO Select 8 Contact Inputs and 8 Contact Outputs, 2 NC, 6NO Select 8 Contact Inputs and 8 Contact Outputs, 3 NC, 5NO								0 1 2 3		
<i>Term.</i>	All Barrier All Compression									S C	

Relay Accessories

Description	Catalog Number
19" rack mount panel adapter for Idea relay	PR6ADRP
19" 2-relay side-by-side mounting adapter for Idea relays	PR6ADJK
6 foot (2m) front panel RS232 cable	F500066001

Specifications

Frequency	50/60 Hz
Voltage Inputs	One voltage input channel 50 – 250 VAC continuous (phase-to-neutral) Burden < 0.1VA at 120V Primary DC Resistance 1,454 Ω Error % < 0.3% over operating temperature
Current Inputs	Nine current input channels $I_{Nominal} = 5A$, $I_{continuous} = 15A$, $I_{3sec} = 150A$, $I_{1sec} = 300A$ Range of overcurrents settings 0.1 A to 90 A Step size 0.01 A Burden < 0.2VA at 5A Primary DC Resistance 3.4 m Ω Error % < 0.3% over operating temperature $I_{Nominal} = 1A$, $I_{continuous} = 3.2A$, $I_{3sec} = 30 A$, $I_{1sec} = 100A$ Range of overcurrents settings 0.02 A to 18 A Step size 0.002 A Burden < 0.2VA at 1A Primary DC Resistance 52.1 m Ω Error % < 0.3% over operating temperature
Digital Inputs (Optically Isolated)	9 – 150 VDC [24 VDC power supply] 36 – 150 VDC [48 VDC power supply] 90 – 300 VDC [120 VAC / 125 VDC power supply] 165 – 300 VDC [240 VAC / 250 VDC power supply] Nominal current draw of 2.5 mA, minimum operating time of 15 msec
Relay Outputs	240 Vac / 250 Vdc. Make: 30A for 0.2 seconds; Carry: 6A continuous. Break: 0.2A (L/R = 40 ms) Pickup time: <8ms; Dropout time: <5ms
Solid-State Outputs	240 Vac / 250 Vdc; Make: 30A for 0.2 seconds; Carry: 8A continuous. Break: 10A (L/R = 40 ms) Pickup time: <1ms; Dropout time: <15ms
Power Supply	24 VDC \pm 20% 48 VDC \pm 20% 120 VAC / 125 VDC \pm 30% 240 VAC / 250 VDC \pm 20% Burden: 14W
Local/Remote communications	EIA-RS-232C: 1 ea. located on front and rear panel Baud Rates: Auto baud rate up to 115,200 bps IRIG-B: 1 located on rear panel Optional Comm. Daughterboards (available with ProView 4.0.1): RS-485 (DC isolated) Modbus 57,600 bps; DNP 38,400 bps Serial Fiber Optic (ST) Ethernet, Multi-Mode, Fiber Optic (MTRJ/MTRJ) Ethernet, Multi-Mode, Fiber Optic / Wire (MTRJ/RJ45) Ethernet, Multi-Mode, Wire (RJ45/RJ45) Ethernet, Single-Mode, Fiber Optic (LC/LC)

IDEA iCP-191 Capacitor Bank Protection Relay

Front Panel Targets	23 Programmable LEDs
Front Panel Display	20 x 4 character LCD
Front Panel Keypad	8 fixed-function keys, 4 multi-function "soft" keys 8 programmable "Hot-Keys"
Dimensions	Idea relay: 3 U high by 8.5" wide; 19" rack mount adapter plates and side by side mounting kits available
Relay Weight	10 lbs
Mounting	Horizontal
Operating Temperature	-40 °F to 158 °F (-40°C to 70 °C) continuous
Bump & Shock Test	IEC 60255-21-2 (1988) Class 1
Cold Temperature Test	IEC 60068-2-1 (1993) 16 hours at -40C
Electrostatic Discharge	EN 61000-4-2 (2001) Levels 1, 2, 3, and 4.
High temperature Test	IEC 60068-2-2 (1993) 16 hours at 70C
Humidity Test	IEC 60068-2-30 (1999) 25C to 55C, 95% Humidity, 2 cycles
Impulse/Dielectric Withstand	IEC 60255-5 (2000) Impulse Test: 5kV, 1.2 μ s rise time, half wave 50 μ s. Applied 3 impulses at each polarity. Dielectric: 3150 VDC for 1 minute. Insulation Resistance: Greater than 10 Gigaohms.
Radio Frequency Interference	Radiated: EN 61000-4-3 (2001) 20 MHz – 1 Ghz, Idea 35 V/m. ANSI/IEEE C37.90.2 (1995) 35V/m from 20 MHz to 1 GHz Conducted: IEC 61000-4-6 (2001) 150 kHz – 80 MHz, 10 Vrms IEC 61000-4-16 (2001) 15 Hz – 150 kHz, 10 Vrms
Surge Withstand	ANSI/IEEE C37.90.1 (2002) 2.5 kV oscillatory, \pm 4 kV fast transient
Vibration Test	IEC 60255-21-1 (1988) Class 1
Contact Rating	ANSI/IEEE C37.90, Section 6.7 (1989) 30A for 0.2 seconds, 2000 operations, at 125 VDC, 250 VDC, and 240 VAC.
Object Penetration	IEC 60529 (2001-02) IP3X rating

Specifications subject to change without notice.

©2007 Cooper Power Systems, Inc., or its affiliates.

ProView, IDEA Workbench, User Workbench, Relay-Replay, and Virtual Test Set
are trademarks of Cooper Power Systems, Inc., or its affiliates.

Edison is a registered trademark of Cooper Power Systems, Inc., or its affiliates.

(Relay Replay United States Patent Number 5,878,375)

Microsoft® Windows® are either registered trademarks or trademarks of
Microsoft Corporation in the United States and/or other countries.