

### iDP-210 Feeder Protection Relay



Figure 1: Edison Idea Relay

The iDP-210 feed protection relay is a member of Cooper Power Systems' Edison<sup>®</sup> Idea line of protective relays. The iDP-210 is a full featured relay suitable for a variety of protection applications including feeder protection, reclosing, synch-check, frequency based load shedding, reverse power, overcurrent, over/under voltage and frequency. The iDP-210 also provides advanced power quality, metering, control, communication and PLC functions.

The iDP-210 uses Cooper Power Systems' ProView<sup>™</sup> software package for PCs running the Microsoft<sup>®</sup> Windows<sup>®</sup> operating system. The *IDEA Workbench<sup>™</sup>* feature of ProView permits the user to add additional functionality to the iDP-210 by means of downloadable Custom Modules. These modules may be obtained from Cooper Power Systems or created by the user. This ability provides a continuous upgrade path that not only protects the initial investment in the relay, but also provides a means to increase the relay's functionality in response to regulatory, power quality and reliability concerns.

#### APPLICATIONS

The iDP-210 is an extremely versatile relay that is well suited for any number of applications that require the use of any or all of its many functions. Typical applications include distribution feeder protection, bus protection, transformer backup protection, line overcurrent protection, co-gen intertie applications, frequency based load shedding applications, over/under voltage protection, generator motoring protection, double wye capacitor bank protection and reclosing with or without synch-check.

#### HIGHLIGHTS

- Add functions and features using the *Idea Workbench<sup>™</sup>*
- Cooper's exclusive ICSF (Incipient Cable Splice Failure) Detection System for underground cables
- Virtual Test Set<sup>™</sup> event record simulator
- Relay Replay<sup>™</sup>: The "what-if" analysis tool.
- Interactive oscillography
- Instantaneous, Demand and Energy Metering
- Harmonics and THD metering
- Load Encroachment and Cold Load Pickup Logic
- Breaker Health Monitoring
- Sequence of Events Recording
- Distance-to-fault calculation
- 6 Voltage Input option
- Eight setting groups
- DNP 3.0 and Modbus protocols standard

#### PROTECTIVE FUNCTIONS

- Fuse-fail detection (27FF)
- Reverse power (32)
- Phase instantaneous, definite time, and inverse time overcurrent (50/51)
- Ground instantaneous, definite time, and inverse time overcurrent (50N/51N)
- Negative-sequence instantaneous, definite time, and inverse time overcurrent (50Q/51Q)
- Multiple-shot programmable reclosing (79)
- Predictive Sync-check (25) with anti-motoring
- Breaker fail-to-trip and fail-to close detection (50BF)
- Directional phase, ground and negative sequence elements (67P, 67N, 67Q)
- Directional neutral (sensitive earth fault optional) protection (50G/50SEF)
- Multiple-Step over/under frequency elements with voltage and current supervision (81)
- Over/under voltage elements (27/59)
- Sequence overvoltage (59P, 59Q, 59N)

## IDEA IDP-210 FEEDER RELAY

To address the needs of automation, EMS and SCADA systems, the iDP-210 also provides advanced power quality, metering, control and communications capabilities.

### TWO HARDWARE PLATFORMS

The iDP-210 is available both in the Idea and IdeaPLUS relay platforms. The IdeaPLUS platform is the same as the Idea platform with the addition of a breaker control panel. See Figure 2. These features eliminate the need for separately mounted breaker controls. This control panel provides:

- Large green and red, self-illuminated breaker TRIP and CLOSE pushbuttons which operate even if the relay is not powered or if it has failed.
- A hardware based Hot Line Tag control or software based Close Circuit Disable switch which, when enabled, blocks the ability of the relay to issue a close command to the circuit breaker<sup>1</sup>.
- Close Circuit disable link. When removed, this link places a physical open in the breaker's close circuit making it impossible to close the breaker via the relay or its CLOSE button under any condition. This is provided in addition to the Hot Line Tag control for those situations when extra security is required.
- Nine additional feature pushbuttons with integral indicating LEDs. These provide instant access to ground trip block, reclose block and supervisory block. Six of the buttons are user configurable in the *IDEA Workbench*.



**Figure 2:** IdeaPLUS Relay Hardware with Integral Breaker Control Panel

### CUSTOMIZE THE iDP-210 WITH THE *IDEA WORKBENCH*<sup>TM</sup>

The iDP-210 is a fully functional relay, ready to use right out of the box. However, there are applications where custom control logic, or custom functions need to be added to the relay. The *IDEA Workbench* is a revolutionary graphical software programming environment which permits the user to customize the iDP-210.

- Add new features or protective functions by means of *IDEA Workbench* Custom Modules. These operate in the same fashion as the plug-ins for popular internet browsers. Your investment in the relay is protected as future needs and developments may be addressed through new Custom Modules.
- Create custom control and protection logic using over 400 programming signals and tools, all selectable from drag-off Toolboxes. Logic created using these tools can then be saved as Custom Modules to be reused or shared with associates.
- Monitor and control practically every aspect of the relay's operation.
- Create custom metering and measurement quantities.
- Create custom sequence of event records.
- Configure communication protocols to match existing SCADA system mappings.

<sup>1</sup> The Close Circuit Disable switch may be cleared remotely by communications.

The *IDEA Workbench* offers the user the ability to rapidly and accurately create customizations by working the way the engineer thinks, by using logic diagram and flowchart construction methods. No equation-based or command-based logic programming is required. See Figure 3.

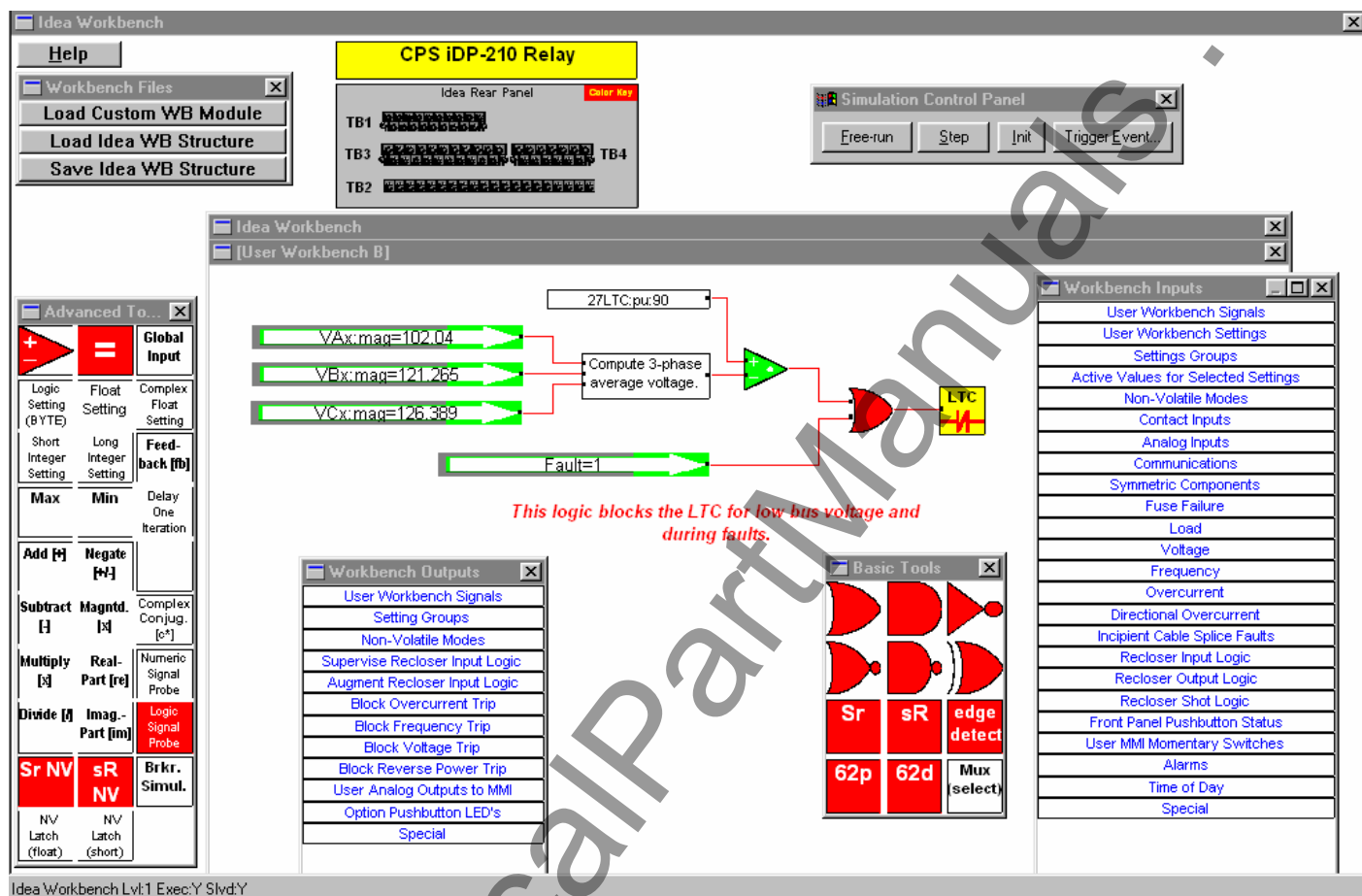

**Figure 3:** The *IDEA Workbench* Graphical Customization Environment

The *IDEA Workbench* also addresses some of the more difficult questions associated with custom relay programming, namely:

**Clarity:** Compared to that offered by equation and command based programming techniques, graphical programming results in customizations whose operation is intuitive and easy to understand.

**Testing:** ProView provides a Virtual Test Set™ (VTS™), which can be used to test the developed logic with real fault signals. During test, the logic diagrams become “live” showing the state of all variables, logic gates, contacts, counters, etc. To avoid any question of how the custom logic interacts with the relay itself, the VTS environment models the entire relay in addition to the custom programming. Unlike other programming environments, the *IDEA Workbench* does not require the user to have an actual relay or relay test set on hand to verify the proper operation of the programmed logic.

**Documentation:** Notes regarding how the custom logic operates may be embedded within the *IDEA Workbench*. This improves the ability of others to quickly understand how the logic is designed to work. Links to external files may also be embedded in the *IDEA Workbench*, providing fast access to larger documents stored on company’s network servers.

**Portability:** If the original data files are lost, the entire *IDEA Workbench* may be uploaded from the relay, complete with logic diagrams, embedded notes and external reference links.

## INCIPIENT CABLE SPLICE FAULT DETECTOR (ICSF)

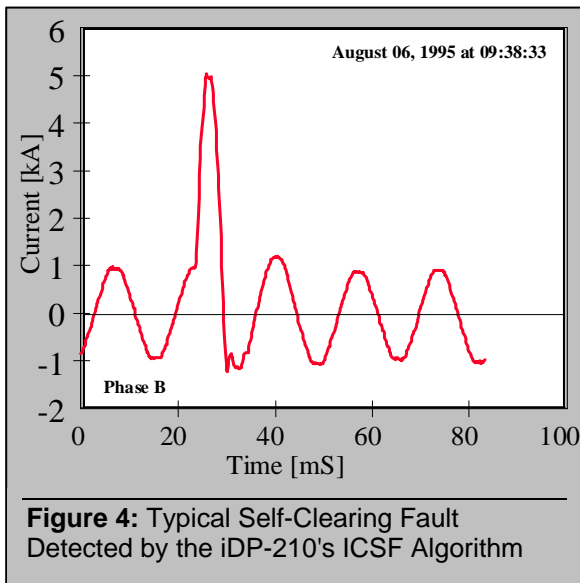

**Figure 4:** Typical Self-Clearing Fault Detected by the iDP-210's ICSF Algorithm

One of the most common causes of buried cable failure is from moisture ingress to buried cable splices. When sufficient water accumulates in a buried cable splice, a line-to-ground fault briefly occurs. The fault is cleared as the water is suddenly converted in to steam. Over time, the insulation is damaged and the cable splice eventually fails. The iDP-210 contains a waveform recognition algorithm, which recognizes the unique characteristics of these self-clearing faults. See Figure 4. By counting how often these events occur over a fixed time window, the iDP-210 is able to give advance notice of pending cable splice failures. This permits cable maintenance to be scheduled rather than addressed on an emergency basis.

## OVERCURRENT PROTECTION

The iDP-210 offers inverse time, definite time (2 levels) and instantaneous elements for phase, residual and negative sequence overcurrent protection. An additional definite time ground overcurrent element is provided for a separate zero-sequence flux summing CT. This fourth current channel input may also be ordered in a sensitive earth fault version which may be set as low as 0.005A secondary. Each overcurrent element

may be independently selected to be non-directional, forward- or reverse-directional. Inverse time elements may be set for disk-like or instantaneous reset characteristics. Complete fuse-fail detection logic is also included to selectively non-directionalize or disable directional elements during loss of bus potential.

## RECLOSING AND SYNCH-CHECK

A fully programmable, 4-shot reclose element, complete with sequence coordination and synch-check supervision is provided. Each protective element in the relay may be independently programmed as to how it interacts with the reclose logic for each shot in the reclose sequence. External relays may also be connected to the iDP-210's reclosing logic with the same configuration capabilities as the relay's own internal protective elements. The iDP-210 may be used as a stand-alone reclosing and/or synch-check relay. The Synch-Check function provides the following features:

- Anticipatory Close accounts for the time it takes the circuit breaker mechanism to actually close once sent a CLOSE command.
- Anti-motoring control assures that synch-check will be declared only when the resulting power flow will be in the specified direction.
- Synch against voltages of different PT ratios and different nominal phase angle displacements (delta vs. wye).
- Anti-pump logic.
- Programmable Hot Bus, Cold Bus, Hot Line and Dead Line operation.

## FREQUENCY ELEMENTS

Five levels of underfrequency plus an additional underfrequency alarm level combine with overfrequency elements to provide comprehensive stand-alone frequency protection. The iDP-210 also includes underfrequency load shedding and restoration logic. The load shedding is both voltage and current supervised. The current supervision is included to ensure that the feeder is carrying a minimum current level before load shedding is permitted. This ensures that a feeder will be disconnected only if sufficient load is present to be useful in saving the system, preventing the disconnection of a lightly loaded feeder which will only have the effect of disconnecting a larger number of customers and lowering a utility's reliability indices.

For restoration, a complete set of integrated timers is provided to allow for both scheduled restoration and the ability to ride through the momentary frequency excursions that occur during a system-wide restoration.

## REVERSE POWER

The iDP-210 provides a reverse power element that may be used for a variety of protective situations. These include generator and motor protection, loop protection and directional power supervision of other protective elements, including lockout of the reclose logic under reverse power conditions, or automatically changing to an alternate setting group when reverse power conditions are sensed. Fuse-fail detection logic is also included to selectively non-directionalize or disable this element during loss of bus potential.

## VOLTAGE ELEMENTS

Numerous phase, zero sequence and negative sequence overvoltage elements are provided. Typical applications include overvoltage and open phasing protection. Phase undervoltage elements are also provided.

## COLD LOAD PICKUP AND LOAD ENCROACHMENT LOGIC

The iDP-210 provides both cold load pickup and load encroachment logic. Cold load pickup logic senses when a feeder is being connected after a period of being de-energized. The logic automatically increases the inverse time and low set definite time phase overcurrent element pickup levels to enable the relay to ride through the increased load current that flows as a result of the newly connected loads.

Load encroachment logic addresses the situation of a feeder operating in steady state conditions where the feeder load current begins to approach or slightly exceed the set overcurrent pickup levels. Examples include:

- Feeders where load growth has made previous settings inappropriate. The Load Encroachment Logic can be set for the feeder's expected maximum future load but set for the present load, reducing the likelihood of false tripping until such time that the feeder's overcurrent settings may be revisited.
- Feeders which may experience very heavy load increases due to contingency situations.

The iDP-210 will block the operation of balanced three phase overcurrent elements as long as the load in the feeder is balanced and is within permissible feeder watt and VAR import/export limits. See Figure 5. This logic will not affect the operation of the relay for any unbalanced fault condition.

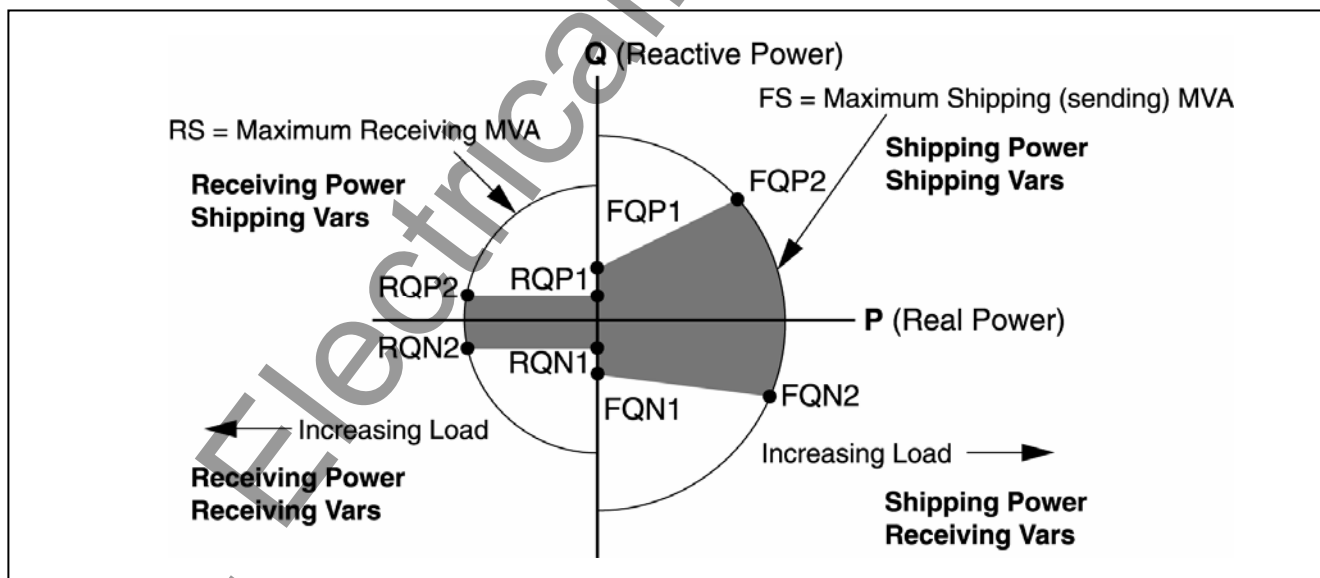

**Figure 5:** Load Encroachment Logic Blocks 3-Phase Overcurrent Elements When Load Falls within the Shaded Area of the Power Plane

### SIX VOLTAGE INPUT OPTION

The iDP-210 is available with two sets of three-phase voltage inputs. This is useful for ring bus or other multi-source applications where the relay may be fed with external voltage inputs from more than one bus. This eliminates the need for external switching relays to route the appropriate voltage signals to the standard single three-phase input. Using the *IDEA Workbench* feature, the relay may be programmed to automatically switch between the x- and y- three phase sources under any arbitrary set of user-defined conditions including external breaker 52a contact inputs. Switching of the voltage banks switches the voltages used for metering as well as protection.

### METERING

The iDP-210 offers extensive metering capabilities, including:

- Instantaneous Volt, Amp, Watt, VARS, pf and frequency in both primary and secondary scaled values.
- Demand metering (current and four quadrant power) with alarm levels
- Energy metering
- Harmonics metering through the 15<sup>th</sup> harmonic including THD for all voltage and all current channels.

### EVENT RECORDS AND ANALYSIS TOOLS

The iDP-210 shares the same event records and analysis tools as all Edison Idea relays. The Edison Idea allows for the display of event records in a variety of formats including waveforms (oscillography), magnitude plots, phasor diagrams, symmetrical component diagrams and more. ProView, the software for the Edison Idea relay, also provides a unique Application Diagram View that provides a one-screen view of everything that is going on in the relay. Many of these event views are also available in On-Line View mode, where it is possible to monitor the status of the relay in real-time, including phasor diagrams, which is ideal for verifying CT phasing during commissioning. The iDP-210 also includes distance to fault indication.

ProView, the software for the Edison Idea relay, also provides a unique Application Diagram View that provides a one-screen view of everything that is going on in the relay. Many of these event views are also available in On-Line View mode, where it is possible to monitor the status of the relay in real-time, including phasor diagrams, which is ideal for verifying CT phasing during commissioning. The iDP-210 also includes distance to fault indication.

### Relay Replay™

To evaluate the effect different settings would have on the relay, the Relay-Replay feature of the Edison Idea software allows the user to make any number of setting changes and replay an existing event using these new settings without the need for an actual relay or expensive test equipment. The operation of every

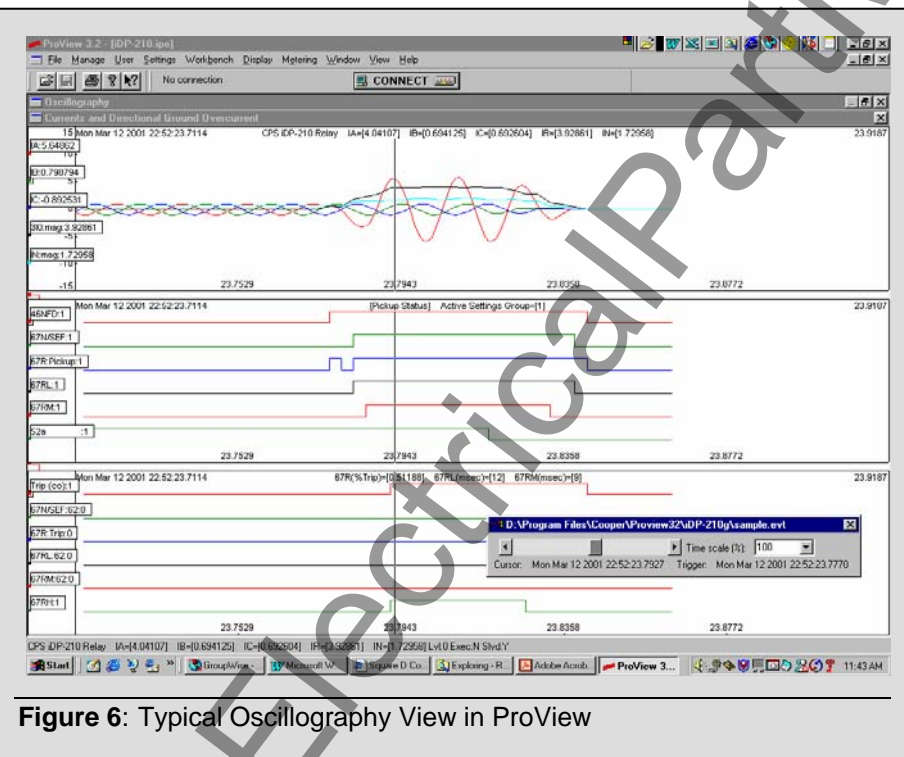

Figure 6: Typical Oscillography View in ProView

aspect of the relay's performance, from which elements pick-up, the response time of those elements that do and the operation of any custom programming made via the *IDEA Workbench* can be observed. This tool provides unprecedented "what-if" analysis capabilities.

### Virtual Test Set™ (VTS™)

To evaluate settings against any arbitrary fault, the Edison Idea software permits the user to create a virtual event record through use of the software's VTS feature. The VTS allows complete control over:

- Pre-fault and post-fault voltage and current levels.
- Selection of phase-ground, phase-phase, phase-phase-ground and three phase fault types.
- Fault duration.
- Selection of system and fault impedances.
- Selection of DC time constant.
- Control over fault dynamics to verify reclosing sequences and sequence coordination.
- Control of frequency change, rate of change and acceleration during faults.
- Control over simulated breaker open and close times.
- Manual mode for manual entry of fault-phasors.

### BREAKER HEALTH MONITORING

To assist in preventative maintenance programs, the iDP-210 monitors a number of critical breaker statistics. These include the circuit breaker's average, maximum and most recent closing and opening times, the accumulated interrupted current and breaker fail-to-trip, slow-to-trip, fail-to-close and slow-to-close conditions.

### COMMUNICATIONS

Both Modbus RTU and DNP 3.0 communication protocols are included with the iDP-210. A *Communications Workbench™* is provided which provides the user the ability to customize communication maps, add or delete information, add control points, and even create new signals to be brought out through communications. The iDP-210 features three auto-baud (57600 kbps max) communication ports: two RS-232 and one RS-485. Contact your Cooper Power Systems representative for availability of other communication protocols.

### ACCESSORY CONTACT I/O BOARD

The iDP-210 comes standard with 5 contact inputs and 5 contact outputs. An optional contact I/O board is available which provides additional contact inputs and outputs. Three of the contact inputs may be specified as being normally closed. Note that if the six voltage input option is ordered, the number of contact inputs is reduced to 11. See Table 1.

**Table 1:** Contact Inputs and Outputs

Relay Platform	Optional I/O Board	Voltage Channels	Contact Inputs	Contact Outputs
Idea	No	4	5	5
	Yes	4	13	13
	Yes	6	11	13
IdeaPLUS	Yes	4	13	15
	Yes	6	11	15

# IDEA IDP-210 FEEDER RELAY

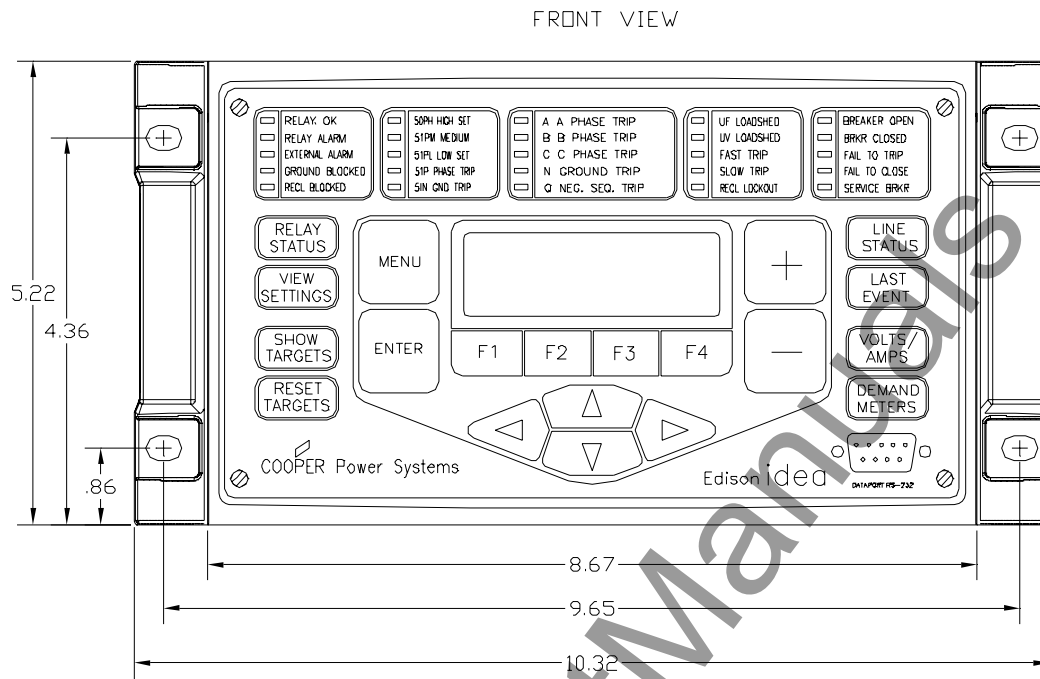

**Figure 7:** Idea Relay, Front View (inches)

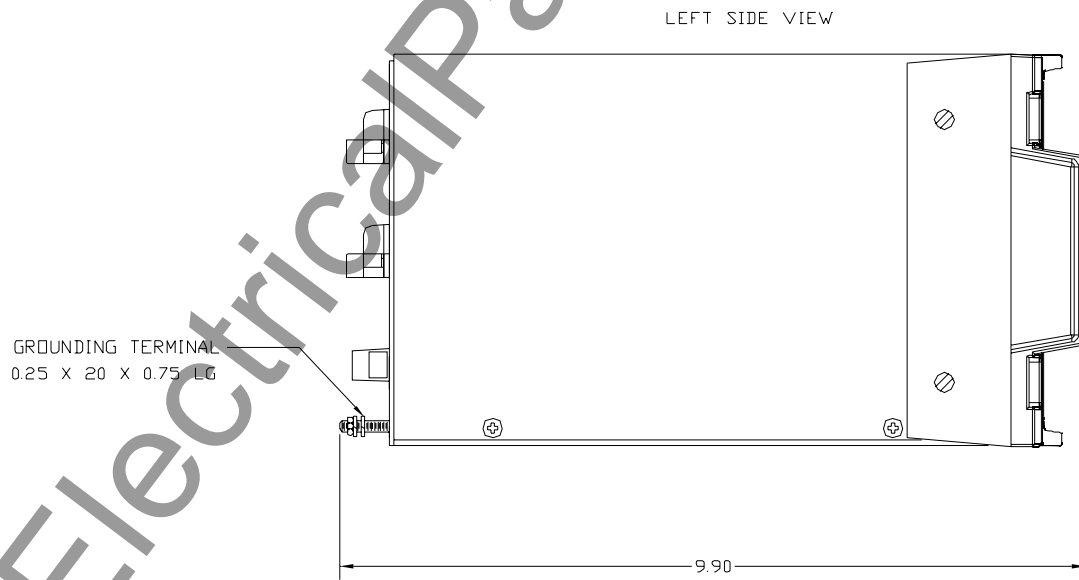

**Figure 8:** Idea Relay, Side View (inches)

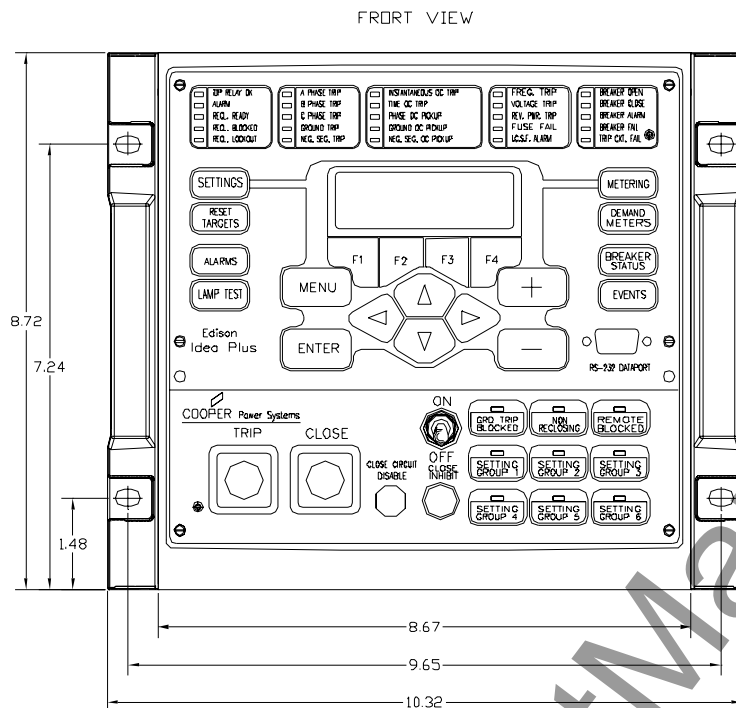

**Figure 9:** Idea PLUS Relay, Front View (inches)

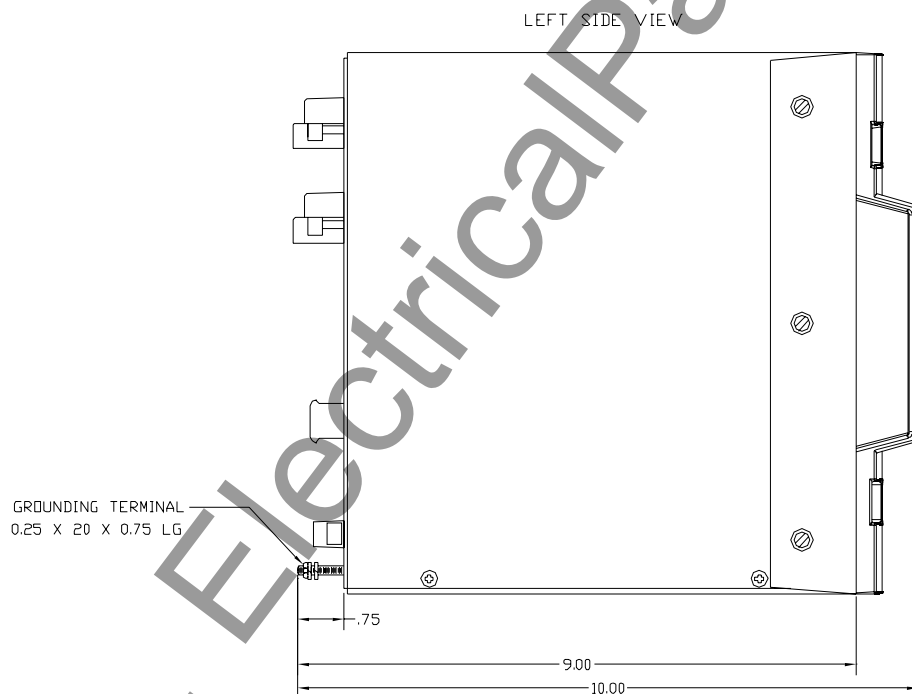

**Figure 10:** IdeaPLUS Relay, Side View (inches)

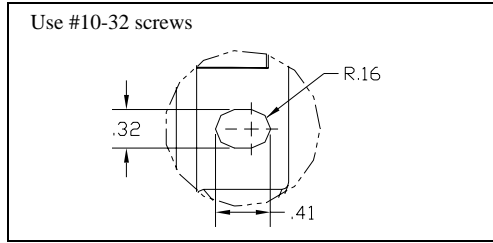

Figure 11: Idea Relay, Mounting Hole Detail (inches)

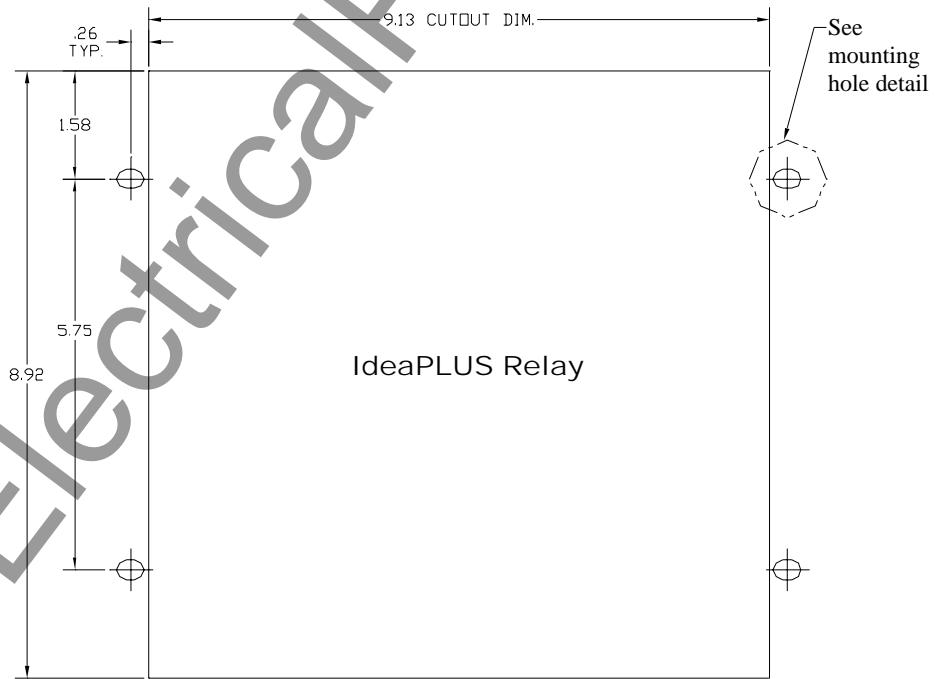
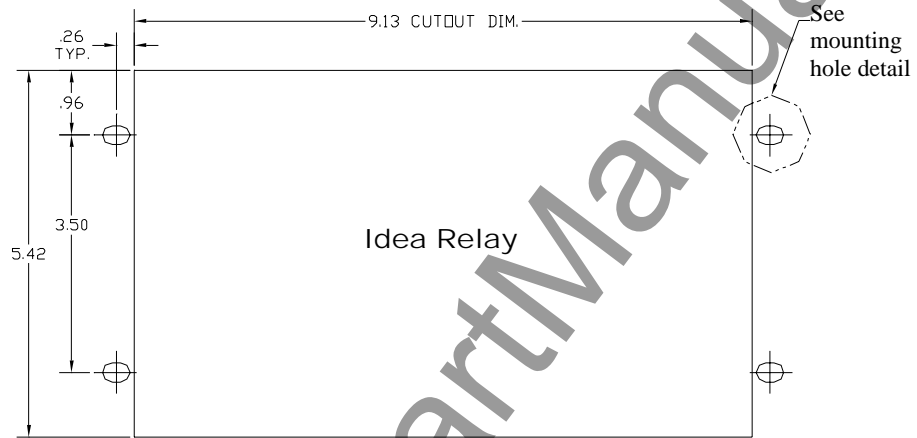

Figure 12: Panel Cutout Dimensions (inches)

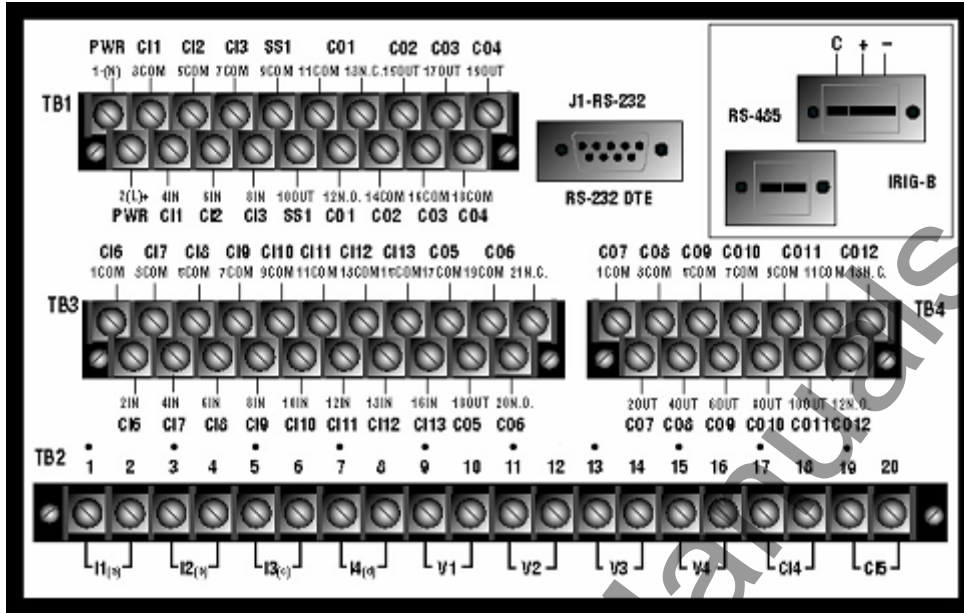

Figure 13: Idea Relay, Rear Panel Details; 4 Voltage Inputs, PR6D2D10xxxxxx Ordering Option

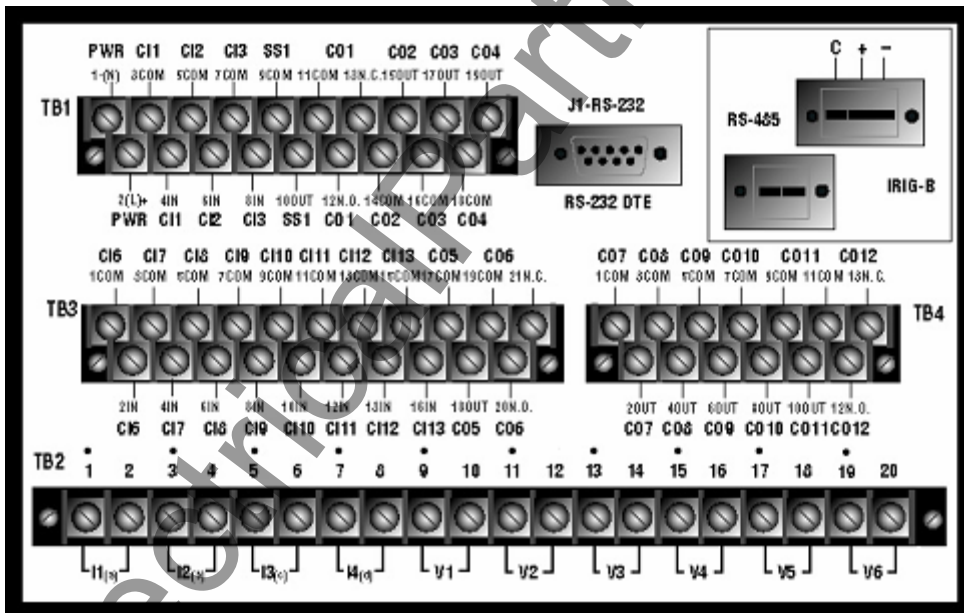

Figure 14: Idea Relay, Rear Panel Details; 6 Voltage Inputs, PR6D2D16xxxxxx Ordering Option

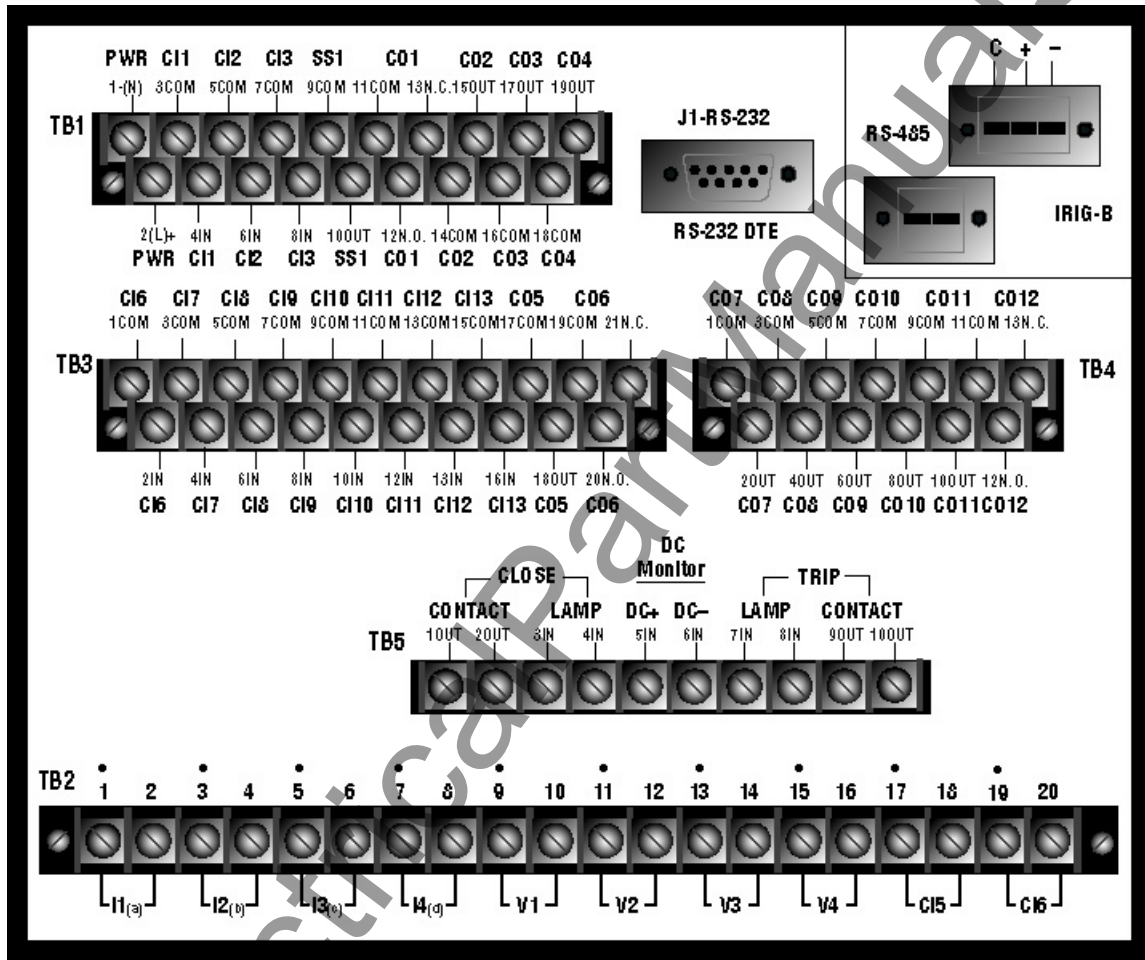

Figure 15: IdeaPLUS Relay, Rear Panel Details; 4 Voltage Inputs, PR6P2D10xxxxxx Ordering Option

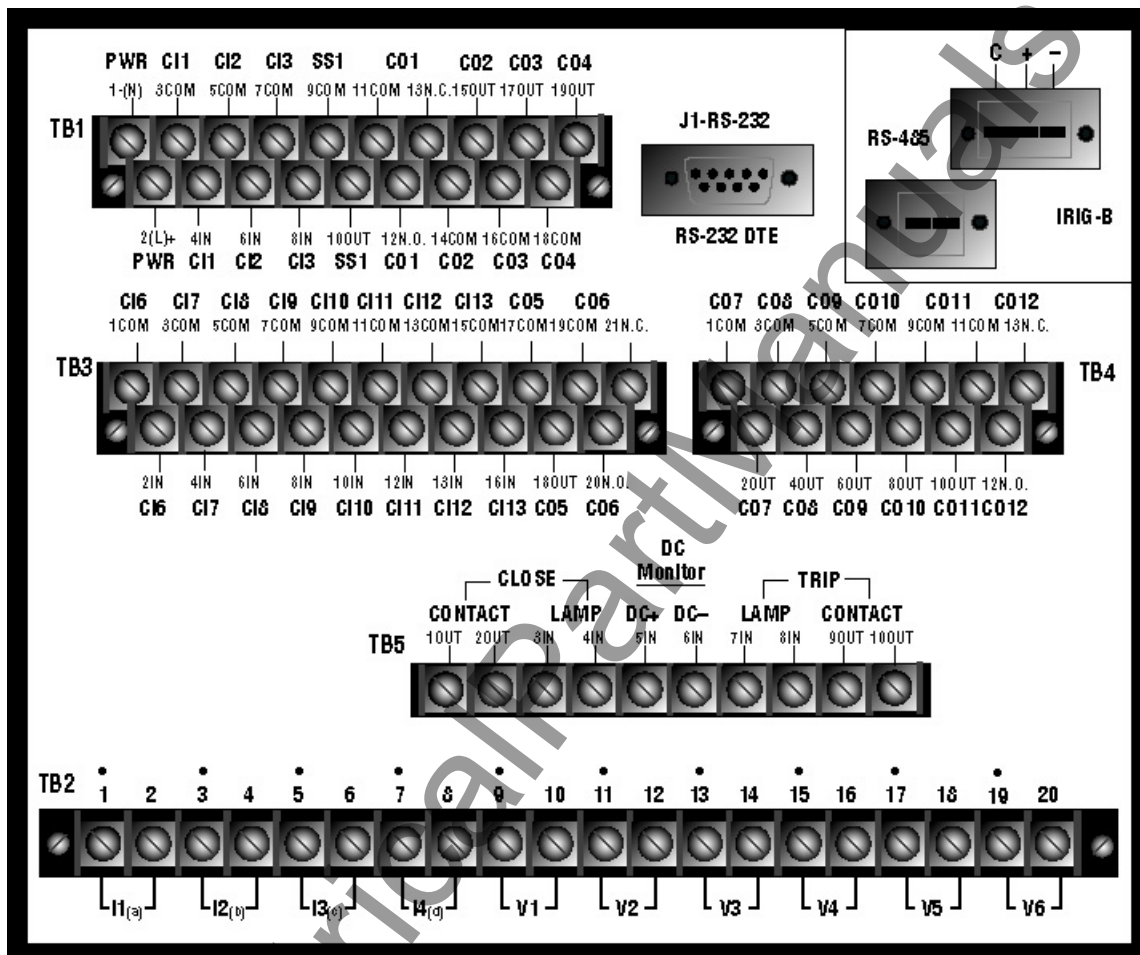
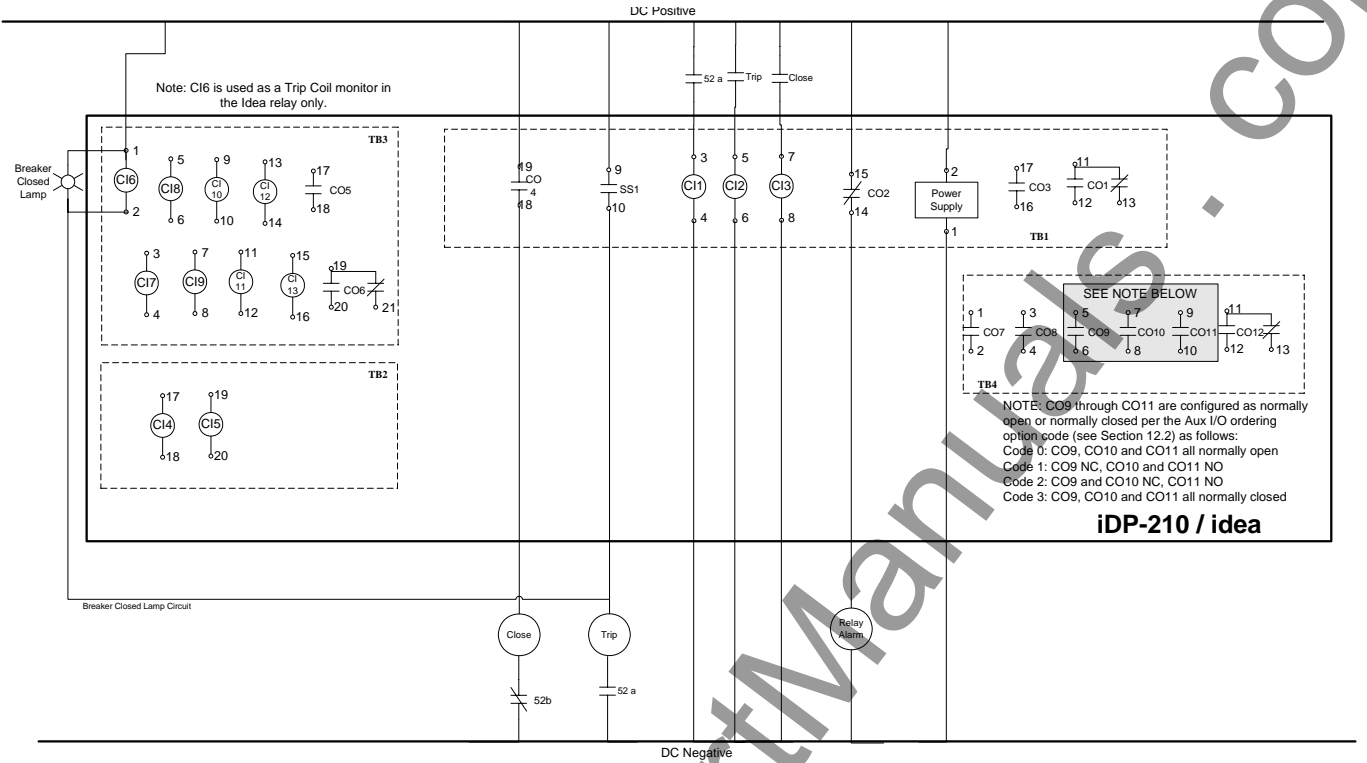

Figure 16: IdeaPLUS Relay, Rear Panel Details; 6 Voltage Inputs, PR6P2D16xxxxxx Ordering Option

# IDEA IDP-210 FEEDER RELAY



**Figure 17:** Edison Idea DC Connection Diagram Where Optional Contact I/O Board IS Present

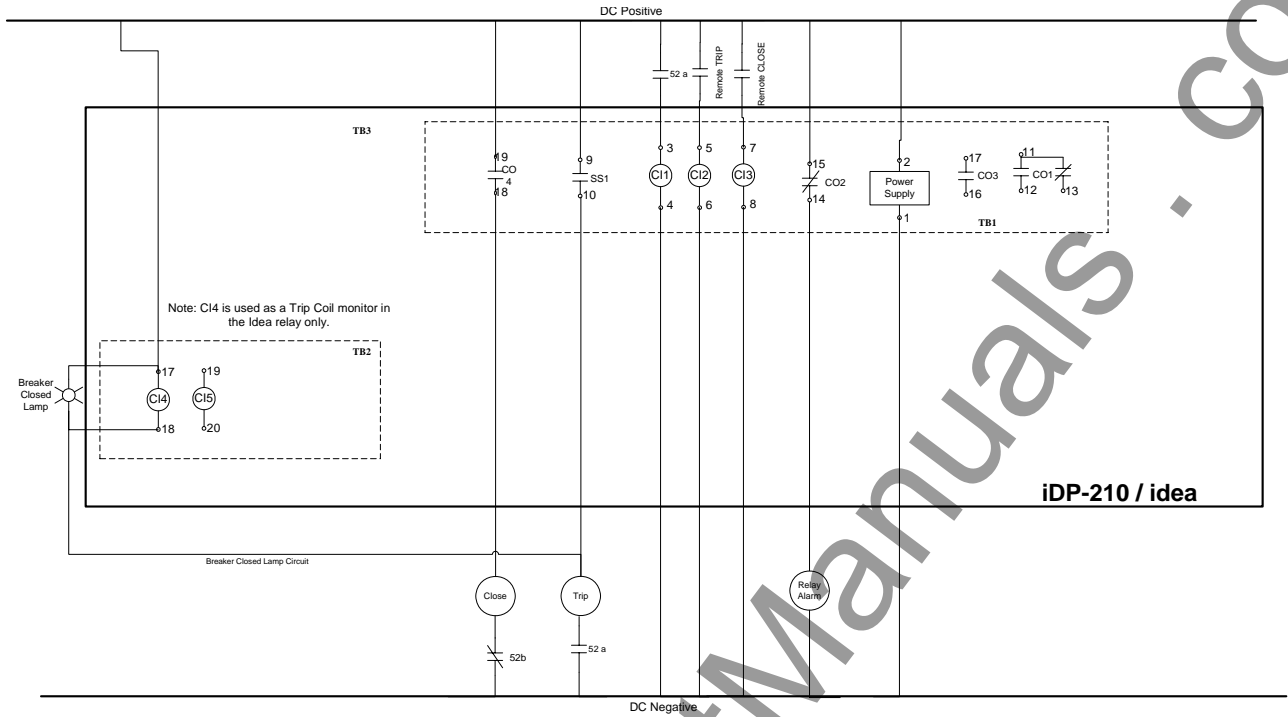
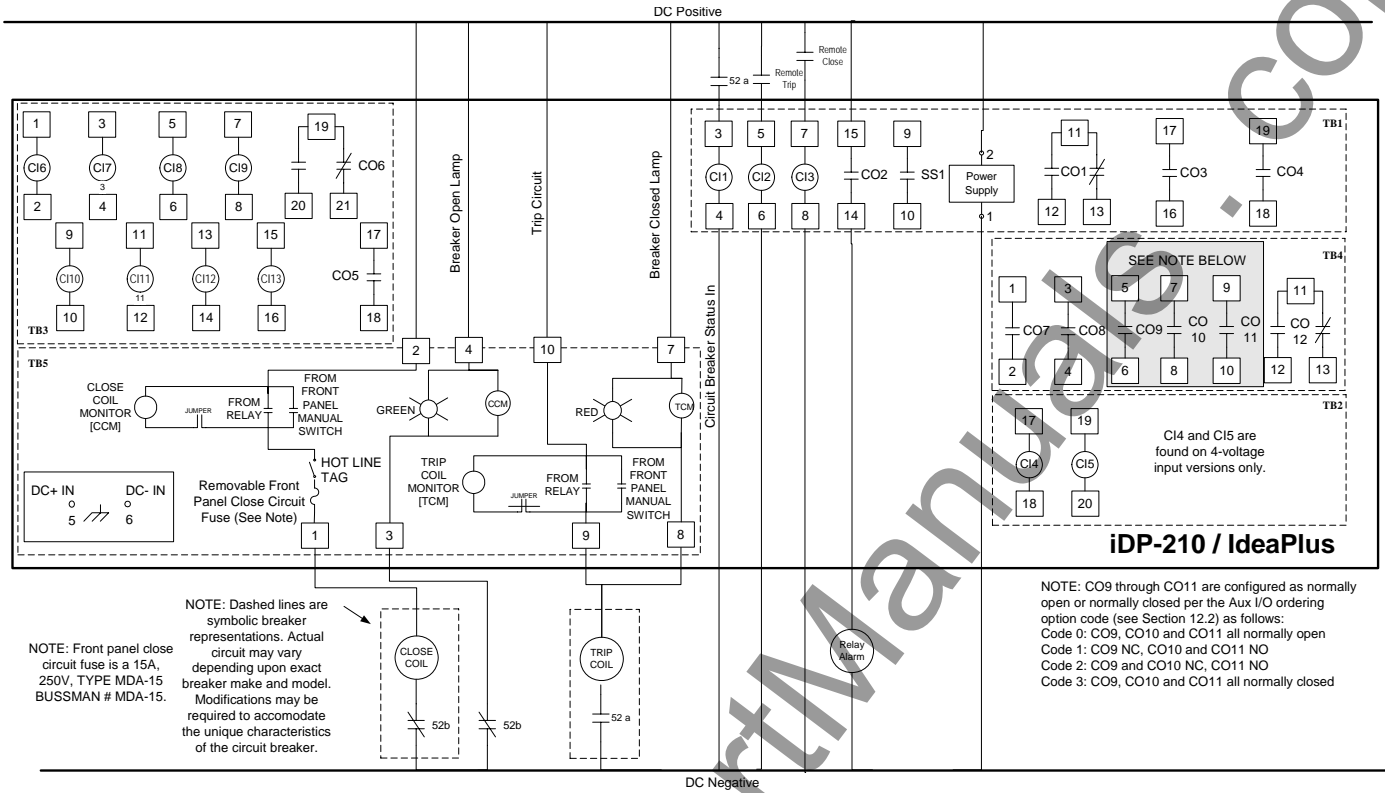

Figure 18: Edison Idea DC Connection Diagram Where Optional Contact I/O Board is NOT Present

# IDEA IDP-210 FEEDER RELAY



**Figure 19:** IdeaPLUS DC Connection Diagram

**Figure 20:** Idea AC Connection Diagram - 4 Voltage Inputs, Normal ABC Phase Rotation  
 Idea PR6D2D10xxxxxx and PR6D2D20xxxxxx Ordering Options  
 IdeaPLUS PR6P2D10xxxxxx and PR6P2D20xxxxxx Ordering Options

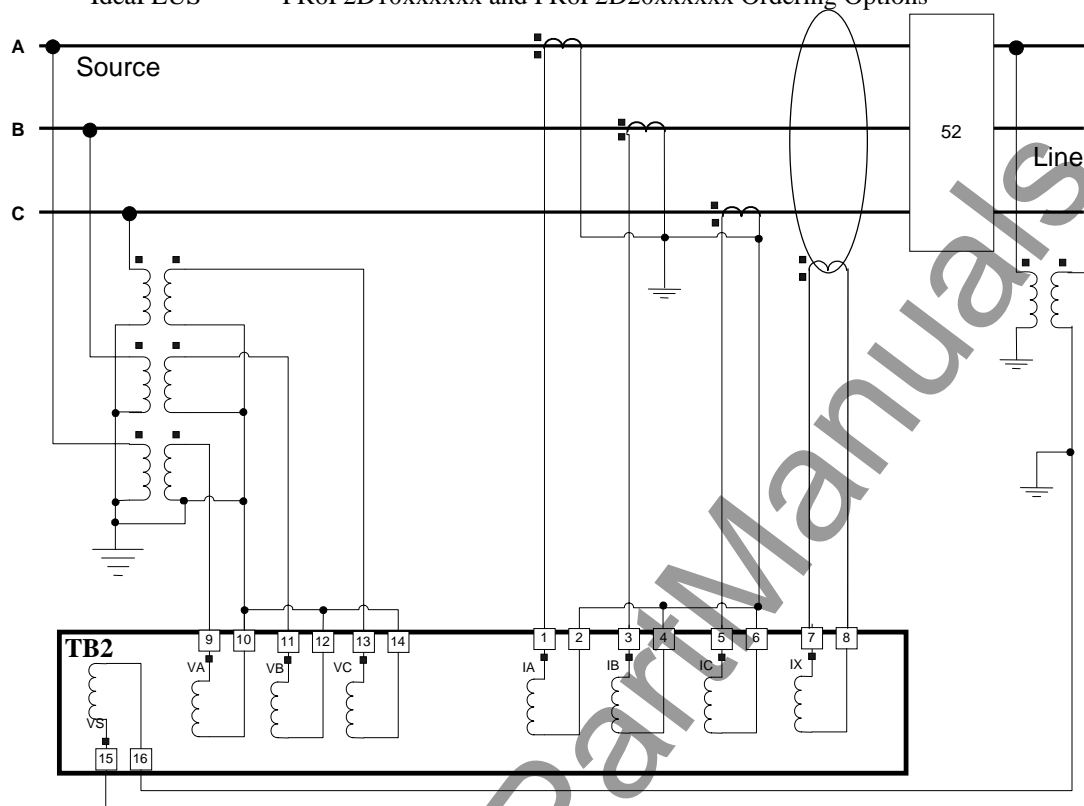

Note:

Terminals 7 and 8 are used for the In or Sensitive Ground Fault (SGF) elements only. The residual overcurrent elements ( $I_r$ ) derive their signals internally from the A, B and C phase current input signals.

**Figure 21:** Idea AC Connection Diagram - 4 Voltage Inputs, ACB Phase Rotation  
 Idea PR6D2D10xxxxxx and PR6DD20xxxxxx Ordering Options  
 IdeaPLUS PR6P2D10xxxxxx and PR6P2D20xxxxxx Ordering Options

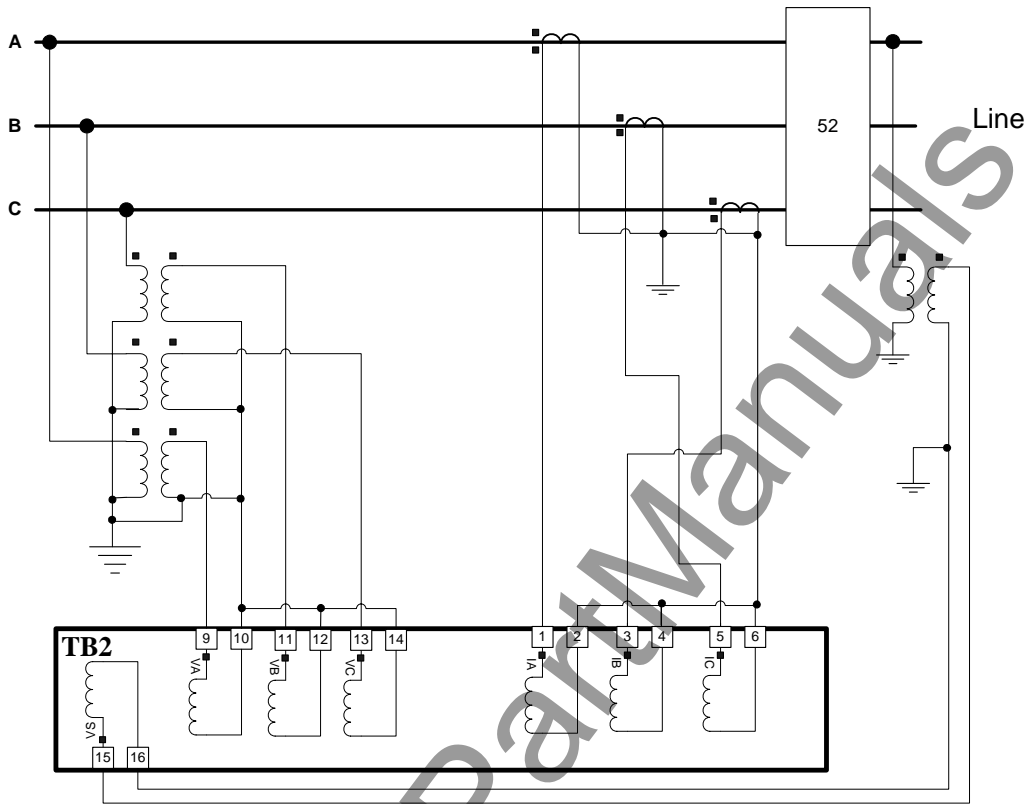

Note:

Terminals 7 and 8 are used for the In or Sensitive Ground Fault (SGF) elements only. The residual overcurrent elements (Ir) derive their signals internally from the A, B and C phase current input signals.

**Figure 22:** Idea AC Connection Diagram - 4 Voltage Inputs, Delta PT Connection  
 Idea PR6D2D10xxxxxx and PR6D2D20xxxxxx Ordering Options  
 IdeaPLUS PR6P2D10xxxxxx and PR6P2D20xxxxxx Ordering Options

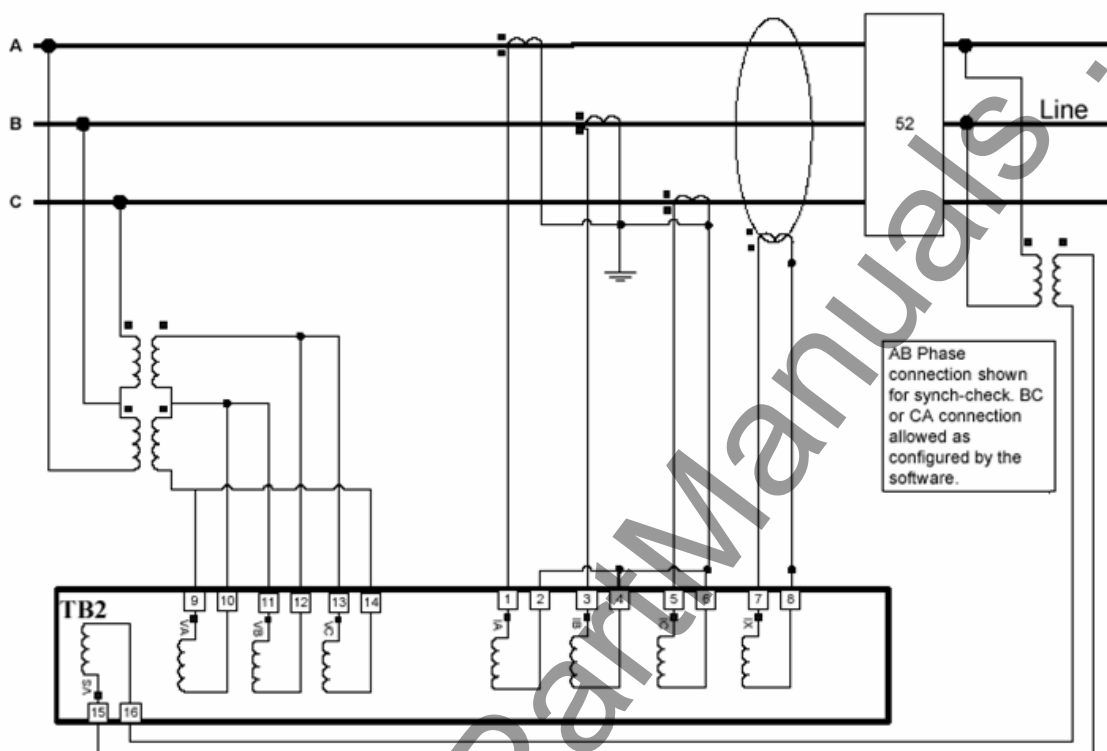

**Note:**

Terminals 7 and 8 are used for the In or Sensitive Ground Fault (SGF) elements only. The residual overcurrent elements (Ir) derive their signals internally from the A, B and C phase current input signals.

## IDEA IDP-210 FEEDER RELAY

**Figure 23:** Idea AC Connection Diagram - 6 Voltage Inputs, Normal ABC Phase Rotation  
Idea PR6D2D16xxxxxx and PR6D2D26xxxxxx Ordering Options  
IdeaPLUS PR6P2D16xxxxxx and PR6P2D26xxxxxx Ordering Options

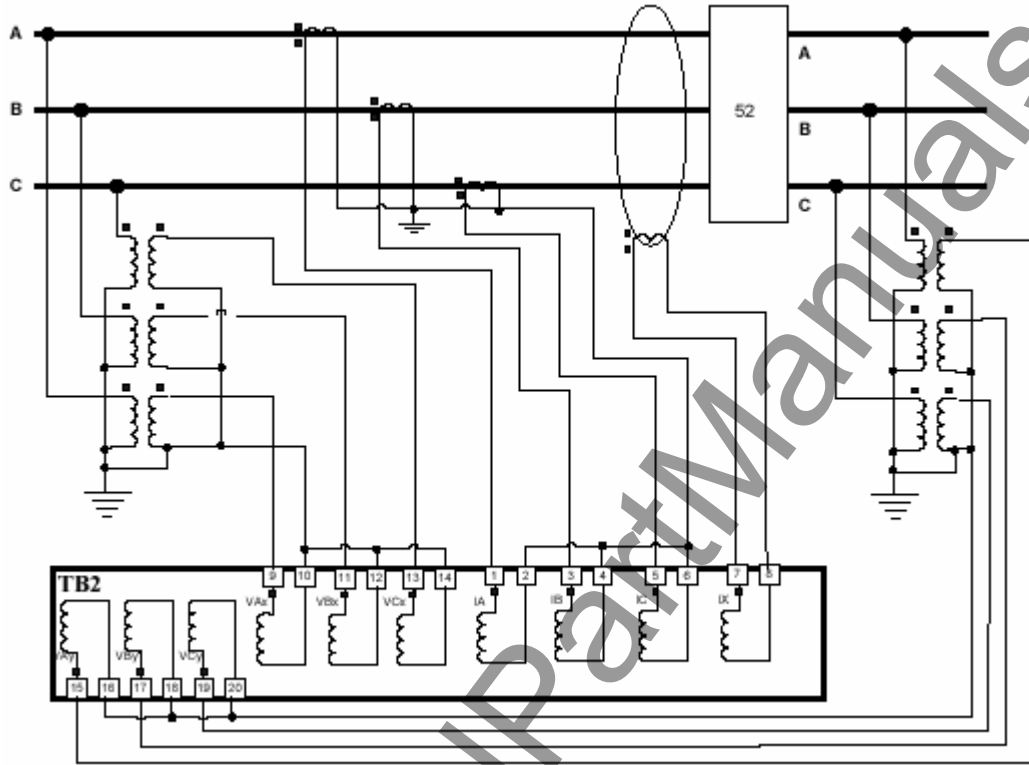

Note:

Terminals 7 and 8 are used for the In or Sensitive Ground Fault (SGF) element only. The residual overcurrent elements (Ir) derive their signals internally from the A, B and C phase current input signals.

**Figure 24:** Idea AC Connection Diagram - 6 Voltage Inputs, ACB Phase Rotation  
 Idea PR6D2D16xxxxxx and PR6D2D26xxxxxx Ordering Options  
 IdeaPLUS PR6P2D16xxxxxx and PR6P2D26xxxxxx Ordering Options

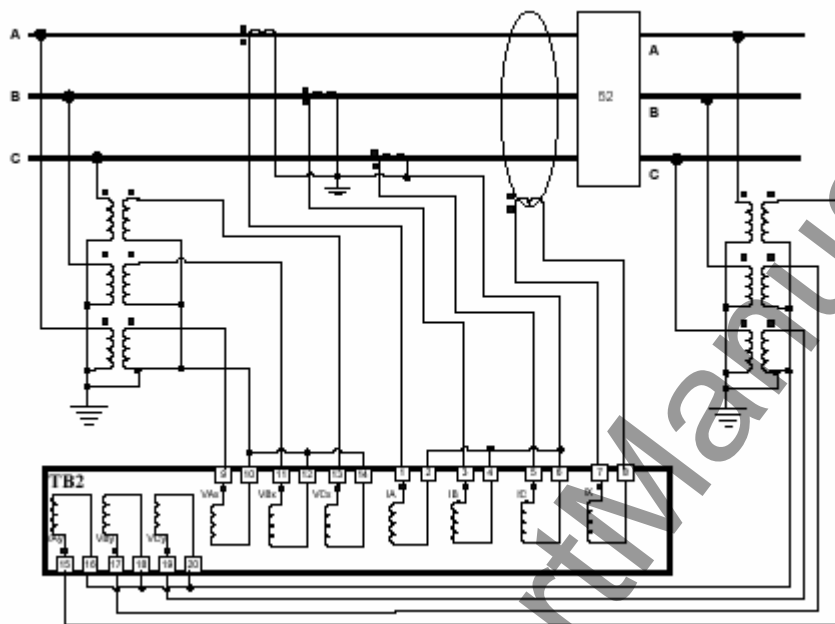

Note:

Terminals 7 and 8 are used for the In or Sensitive Ground Fault (SGF) element only. The residual overcurrent elements (Ir) derive their signals internally from the A, B and C phase current input signals.

# IDEA IDP-210 FEEDER RELAY

**Figure 25:** Idea AC Connection Diagram - 6 Voltage Inputs, Delta PT Connection  
Idea PR6D2D10xxxxxx and PR6D2D26xxxxxx Ordering Options  
IdeaPLUS PR6D2D16xxxxxx and PR6P2D26xxxxxx Ordering Options

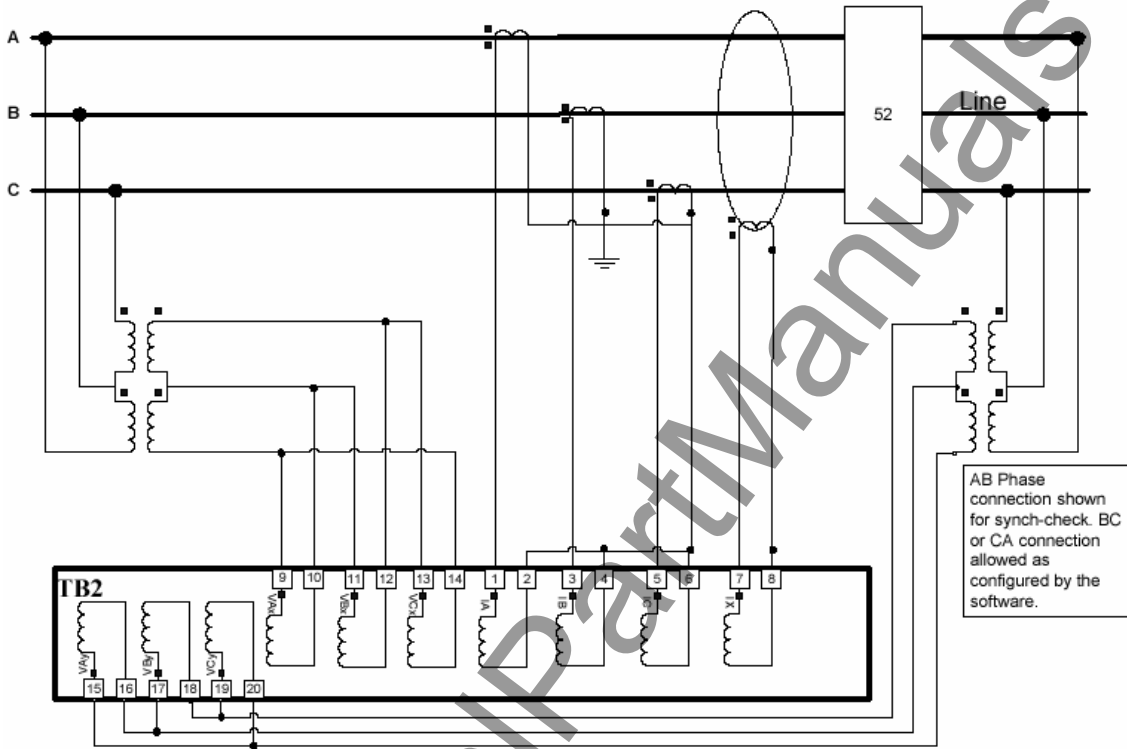

**Note:**

Terminals 7 and 8 are used for the In or Sensitive Ground Fault (SGF) element only. The residual overcurrent elements (Ir) derive their signals internally from the A, B and C phase current input signals.

Table 2 – Ordering Options

NOTE: Tagging and Lamp Style options (columns J and K) apply only to IdeaPLUS part numbers.

Construct Catalog Number from this table.

Sample Catalog Number:

A	B	C	D	E	F	G	H	I	J	K
Idea and IdeaPlus										IdeaPlus
Product	Enclosur	Scheme	Language	Power	Input Range	Protocol	Aux I/O	TermBlock	Tagging	Lamp Style.
PR6										
PR6	P2	D10	E	1	5	A	N	S	T	3

<i>TYPE</i>	Edison Idea/IdeaPlus Relay Edison Idea Chassis Edison IdeaPlus Chassis	PR6 D2 P2								
<i>Scheme/ Model</i>	iDP-210 Feeder Relay iDP-210 Feeder Relay w/2 sets of 3-phase voltage inputs iDP-210 Feeder Relay with SEF iDP-210 Feeder Relay with SEF and 2, 3-phase VT inputs	D10 D16 D20 D26							Idea Requires Aux I/O Board Idea Requires Aux I/O Board	
<i>Inserts Language</i>	English French Portuguese Spanish Other	E F P S O								
<i>Power</i>	48VDC Power Supply 125VDC/120VAC Power Supply 250VDC/240VAC Power Supply Other	4 1 2 X								
<i>Input Ranges</i>	5 Amp CT Inputs, 67/120V PT Inputs 1 Amp CT Inputs, 67/120V PT Inputs	5 1								
<i>Comm. Protocol</i>	RS 485 Fiber Serial Ethernet: Multimode Fiber MTRJ/MTRJ Ethernet: Multimode Fiber MTRJ/ Wire RJ 45 Ethernet: Wire RJ45/RJ45 Standard: None Ethernet: Single Mode Fiber LC/LC	1 3 4 5 6 7 8								
<i>Aux I/O</i>	No additional Contact I/O Add 8 Contact Inputs and 8 contact outputs, all N.O Add 8 Contact Inputs and 8 contact outputs, 1 NC, 7NO Add 8 Contact Inputs and 8 contact outputs, 2 NC, 6NO Add 8 Contact Inputs and 8 contact outputs, 3 NC, 5NO	N 0 1 2 3								
<i>Term.</i>	All Barrier All Compression	S C								
<i>Tag Type</i>	Mechanical Hot-Line Tag, CLOSE inhibited on relay fail Mechanical Hot-Line Tag, CLOSE enabled on relay fail Software based Close-inhibit, CLOSE inhibited on relay fail Software based Close-inhibit, CLOSE enabled on relay fail	T A C R								
<i>Trip/Close Lamp Type</i>	125VDC/120VAC LED Lamps for Trip and Close Status 48 VDC LED Lamps for Trip and Close Status 24VDC LED Lamps for Trip and Close Status 48VDC Incandescent Lamps for Trip and Close Status 24 VDC Incandescent Lamps for Trip and Close Status Other No Bulbs	3 2 1 7 6 X 0								

## IDEA IDP-210 FEEDER RELAY

---

<b>Accessories:</b>	<b>Description</b>	<b>Catalog Number</b>
	19" rack mount panel adapter for Idea relay	PR6DRP
	19" rack mount panel adapter for IdeaPLUS relay	PR6PRP
	19" 2-relay side-by-side 19" rack mount adapter for	PR6ADRPDR
	19" 2-relay side-by-side 19" rack mount adapter for	PR6APRPDR
	6 foot (2m) front panel RS232 cable	<i>KM5-665</i>

www.ElectricalPartManuals.com

**TABLE 3: HARDWARE SPECIFICATION**

Frequency	50/60 Hz
Voltage Inputs	Four voltage input channels 50 - 250 VAC continuous (phase-to-neutral)
Current Inputs	Current input channels $I_{\text{Nominal}} = 5\text{A}$ , $I_{\text{continuous}} = 15\text{A}$ , $I_{3\text{sec}} = 150\text{A}$ , $I_{1\text{sec}} = 300\text{A}$ Burden <0.2VA at 5A Primary DCR 3.4 mW Error % <0.3  $I_{\text{Nominal}} = 1\text{A}$ , $I_{\text{continuous}} = 3.2\text{A}$ , $I_{3\text{sec}} = 30\text{A}$ , $I_{1\text{sec}} = 100\text{A}$ Burden <0.2VA at 1A Primary DCR 52.1 mW Error % <0.3
Digital Inputs (Optically Isolated)	48 or 125 or 250 Vdc $\pm 20\%$ , nominal current draw of 5mA, minimum operating time of 5msec
Relay Outputs	240 Vac / 250 Vdc Make: 30A for 0.2 seconds; Carry: 8A continuous Break: 0.2A (L/R = 40 ms) Pickup time: <8ms; Dropout time: <5ms
Solid-State Outputs	240 Vac / 250 Vdc Make: 30A for 0.2 seconds; Carry: 8A continuous Break: 10A (L/R = 40 ms) Pickup time: <1ms; Dropout time: <15ms
Power Supply	48 Vdc +/- 20% 120 Vac / 125 Vdc +/- 30% 250 Vdc +/- 20% Burden: 14W Ride-through on loss of power: 60msec
Local/Remote communications	EIA-RS-232C, 1 ea. located on front and rear panel Baud Rates: Auto baud rate up to 57,600 bps
Front Panel Targets	25 Programmable LEDs
Front Panel Display	20 x 4 character LCD
Front Panel Keypad	8 fixed-function keys, 4 multi-function "soft" keys 8 programmable "Hot-Keys"
Dimensions	3 U high by 8.5" wide
Relay Weight	10 lbs.
Mounting	Horizontal

## IDEA IDP-210 FEEDER RELAY

---

<b>Operating Temperature</b>	-40 °F to +158 °F (-40°C to +70 °C) continuous (below s/n 2000)
	-40 °F to +158 °F (-40°C to +75 °C) continuous (above s/n 2000)
	-40 °F to +185 °F (-40°C to +85 °C) up to 16 hrs
<b>Bump &amp; Shock Test</b>	IEC 255-21-2
<b>Cold Temperature Test</b>	IEC 68-2-1
<b>Electrostatic Discharge</b>	EN 61000-4-2
<b>Environmental Withstand</b>	IEC 68-2-30
<b>High temperature Test</b>	IEC 68-2-2
<b>Humidity Test</b>	IEC 68-2-30
<b>Impulse/Dielectric Withstand</b>	IEC 255-5
<b>Radio Frequency Interference</b>	EN 61000-4-3 150kHz-1Ghz 1GHz – 18 Ghz
<b>Surge Withstand</b>	ANSI/IEEE C37.90.1
<b>Vibration Test</b>	IEC 255-21-1

*Specifications subject to change without notice.*

[www.ElectricalPartManuals.com](http://www.ElectricalPartManuals.com)

ElectricalPartManuals.com

©2007 Cooper Power Systems, Inc., or its affiliates.  
Edison is a registered trademark of Cooper Power Systems, Inc., or its affiliates.  
ProView, Idea, Idea Workbench, Communications Workbench, Virtual Test Set, VTS,  
Relay-Replay and ICSF are trademarks of Cooper Power Systems, Inc., or its affiliates.

This product is covered by US Patents 6,198,401 and 6,271,759.  
(Relay Replay United States Patent Number 5,878,375)

Microsoft® Windows® are either registered trademarks or trademarks of  
Microsoft Corporation in the United States and/or other countries.

