

iXP-420 Transformer Protection Relay



Figure 1: Edison Idea Relay

The iXP-420 is a member of Cooper Power Systems' Edison® Idea™ line of protective relays. The iXP-420 is a full-featured relay suitable for a variety of protection applications especially for two-winding transformer protection, monitoring, and monitoring and control. The iXP-420 also provides advanced power quality, metering, control, communication and PLC functions.

The iXP-420 uses Cooper Power Systems' ProView™ software package for PCs running the Microsoft Windows® operating system. The *IDEA Workbench™* feature of ProView permits the user to add additional functionality to the iXP-420 by means of downloadable Custom Modules. These modules may be obtained from Cooper Power Systems or created by the user. This ability provides a continuous upgrade path that not only protects the initial investment in the relay, but also provides a means to increase the relay's functionality in response to regulatory, power quality and reliability concerns.

APPLICATIONS

The iXP-420 is an extremely versatile relay that is well suited for any number of applications that require the use of any or all of its many functions. Typical applications include: transformer differential and/or backup protection, restricted earth fault protection, bus differential protection, bus backup protection, multi-feeder frequency based load shedding and restoration schemes, and over/under voltage protection. The iXP-420 also provides control for both high and low side circuit breakers.

Advanced power quality, metering, control and communications capabilities address the needs of automation, EMS and SCADA systems.

HIGHLIGHTS

- Add new functions and features using IDEA Workbench™ Custom Modules.
- Selectable transformer winding configuration.
- Multi-feeder frequency load shedding and restoration logic.
- Selective tripping of both high and low side breakers.
- Breaker health monitoring for both controlled breakers.
- Trip coil monitoring (and close coil monitoring on the IdeaPLUS hardware version).
- Front panel programmability of all relay settings.
- Virtual Test Set™ event record simulator.
- Relay Replay™: The "what-if" analysis tool.
- Interactive oscillography and Sequence of Events Recording.
- Amps, Volts, Watts and VAR metering.
- Demand and Energy Metering
- Eight setting groups.
- Programmable front panel pushbuttons and targets.

PROTECTIVE FUNCTIONS

- Two levels of over-excitation (V/Hz) protection (24)
- Under- and over-voltage (27/59)
- Fuse-fail detection (27FF)
- Phase overcurrent (50/51) for each winding.
- Residual overcurrent for each winding (50R/51R).
- Ground overcurrent with separate CT input for low side winding (50N/51N)
- Negative-sequence overcurrent (50Q/51Q) for each winding.
- Breaker fail-to-trip and fail-to close for both breakers.
- Sequence overvoltage (59P, 59Q, 59N) and positive sequence undervoltage (27P)
- Multiple-Step over/under frequency elements with voltage and current supervision (81)
- Differential protection element (87-1) with dual slope bias characteristic and adjustable knee-point.
- High set differential element (87-2) for fast response to large magnitude internal faults.
- Adjustable 2nd and 5th harmonic blocking on the main differential element.
- Restricted earth fault (87N).

TWO HARDWARE PLATFORMS

The iXP-420 is available both in the Idea and IdeaPLUS relay platforms. The IdeaPLUS platform is the same as the Idea platform shown in Figure 1 with the addition of a breaker control panel. See Figure 2. These features eliminate the need for separately mounted breaker controls. This control panel provides:

- Large green and red, self illuminated breaker TRIP and CLOSE pushbuttons that operate even if the relay is not powered or if it has failed. These buttons are normally configured to operate one of the two breakers, though the user may choose to operate both breakers simultaneously.
- Close Inhibit switch which, when enabled, blocks the ability of the relay to issue a close command to the circuit breaker¹.
- Close Circuit disable link. When removed, this link places a physical open in the breaker's close circuit making it impossible to close the breaker via the relay or its CLOSE button under any condition. This is provided in addition to the Close Inhibit control for those situations when extra security is required.
- Nine additional programmable feature pushbuttons with integral indicating LEDs.



Figure 2: Idea Plus Relay Hardware with Integral Breaker Control Panel

CUSTOMIZE THE IXP-420 WITH THE *IDEA WORKBENCH*[™]

The iXP-420 is a fully functional relay, ready to use right out of the box. However, there are applications where custom control logic, or custom functions need to be added to the relay. The *IDEA Workbench* is a revolutionary graphical software programming environment which permits the user to customize the iXP-420.

- Add new features or protective functions by means of *IDEA Workbench* Custom Modules. Your investment in the relay is protected as future needs and developments may be addressed through new Custom Modules.
- Create custom control and protection logic using over 400 programming signals and tools, all selectable from drag-off Toolboxes. Logic created using these tools can then be saved as Custom Modules to be reused or shared with associates.
- Reassign targets and front panel pushbutton functionality.
- Create and display custom text messages.
- Monitor and control practically every aspect of the relay's operation.
- Create custom metering and measurement quantities.
- Create custom sequence of event records.
- Configure communication protocols to match existing SCADA system mappings.

The *IDEA Workbench* offers the user the ability to rapidly and accurately create customizations by working the way the engineer thinks, using logic diagram and flowchart construction methods. No equation based or commands based logic programming is required. See Figure 3.

¹ The Close Inhibit switch may be cleared remotely by communications unless Supervisory control is disabled from the relay's front panel.

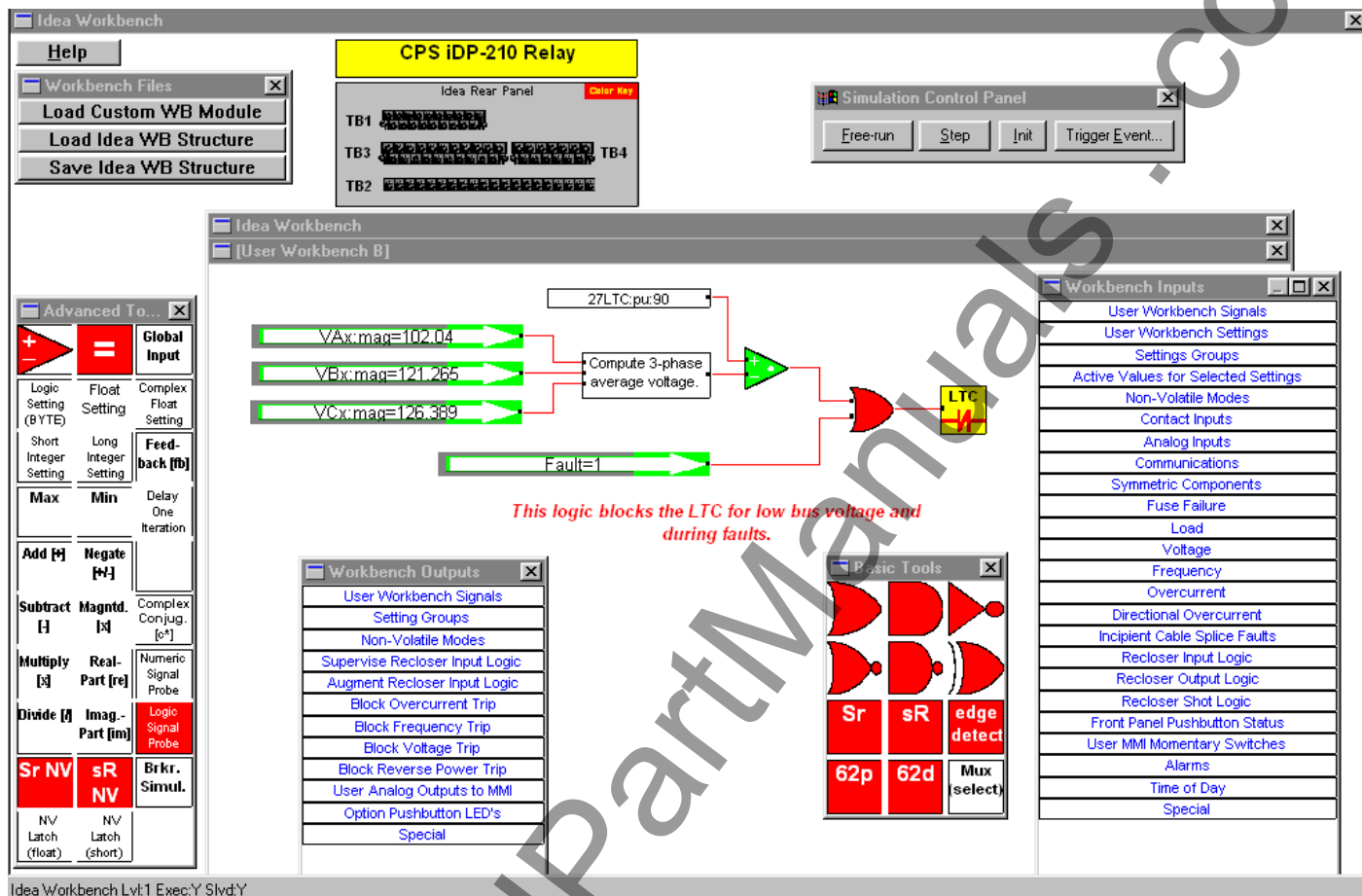

Figure 3: The *IDEA Workbench* Graphical Customization Environment

The *IDEA Workbench* also addresses some of the more difficult questions associated with custom relay programming, namely:

Clarity: Compared to that offered by equation and command based programming techniques, graphical programming results in customizations whose operation is intuitive and easy to understand.

Testing: ProView provides a Virtual Test Set™ (VTS™) that can be used to test the developed logic with realistic fault signals. During test, the logic diagrams become “live” showing the state of all variables, logic gates, contacts, counters, etc. To avoid any question of how the custom logic interacts with the relay itself, the VTS environment models the entire relay in addition to the custom programming. Unlike other programming environments, the *IDEA Workbench* does not require the user to have an actual relay or relay test set on hand to verify the proper operation of the programmed logic.

Documentation: Notes regarding how the custom logic operates may be embedded within the *IDEA Workbench*. This improves the ability of others to quickly understand how the logic is designed to work. Links to external files may also be embedded in the *IDEA Workbench*, providing fast access to larger documents stored on company's network servers.

Portability: If the original data files are lost, the entire *IDEA Workbench* may be uploaded from the relay, complete with logic diagrams, embedded notes and external reference links.

PERCENTAGE AND HARMONIC RESTRAINED DIFFERENTIAL PROTECTION

The percentage restrained differential element offers a dual slope characteristic. Both 2nd and 5th harmonic blocking are provided and may be disabled. The dual slope characteristic has an adjustable kneepoint. See operating characteristic below.

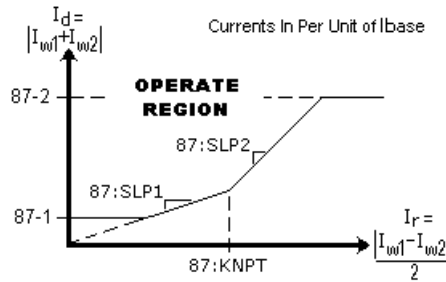

Figure 4: Dual Slope Percent Bias Restraint Characteristic for 87-1 Element

- Minimum differential pickup current (87-1): 0.02 – 4.00 differential current, per unit
- First bias zone slope (87:SLP1): 5 – 200%
- Kneepoint between slope 1 and 2 (87:KNPT) 0.05 – 20.00 per unit
- Second bias zone slope (87:SLP2): 10 – 500%
- 2nd Harmonic restraint level 0.01 – 1.00 pu of differential current
- 5th Harmonic restraint level 0.01 – 1.00 pu of differential current

HIGH SET DIFFERENTIAL PROTECTION

An unrestrained high set differential element provides fast clearing for high magnitude faults. To effectively eliminate the effects of dc offsets and harmonics, the relay trips on the sensing of sequential positive and negative peak currents whose magnitude exceeds the high set trip level.

- Minimum differential pickup current (87-2): 1.00 – 30.00 differential current, per unit

DIFFERENTIAL ELEMENT OPERATING TIMES

Element	Minimum	Typical	Maximum
87-1	2.0 cycles	2.5 cycles	3.0 cycles
87-2	1.25 cycles	1.5 cycles	2.0 cycles

RESTRICTED EARTH FAULT ELEMENT (87N)

The iXP-420 includes a restricted earth fault element for protection of the grounded leg of the transformer. This element performs a differential comparison of the winding’s residual current flowing and the actual neutral current flowing through the grounded leg as sensed via a separate CT input. This differential element incorporates the same dual slope restraint characteristic as the 87-1 element. See Figure 5.

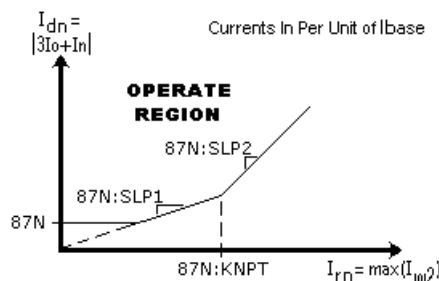

Figure 5: Dual Slope Percent Bias Restraint Characteristic for Restricted Earth Fault Element

Minimum differential pickup current (87N):	0.05 – 4.00 differential current, per unit
Pickup time delay	0 – 3600 seconds
First bias zone slope (87N:SLP1):	5 – 200%
Second bias zone slope (87N:SLP2):	10 – 500%
Kneepoint between slope 1 and 2 (87N:KNPT)	0.05 – 20.00 per unit

OVERCURRENT PROTECTION

For each winding, the iXP-420 offers inverse and instantaneous elements for phase, residual and negative sequence overcurrent protection. For windings that are grounded, a separate ground CT input channel provides true ground overcurrent protection for this winding.

Definite Time

One positive (50P), negative sequence (50Q) and residual (50R) elements each for both high side (50PW1 etc.) and low side (50PW2, etc) windings are provided. A ground overcurrent element (50NW2) is also provided for the low side winding.

Pick-up range 50P and 50Q elements	0.1 to $90A_{\text{secondary}}$
Pick-up range 50R and 50N elements	0.05 to $90A_{\text{secondary}}$
Time delay	0 to 3600 seconds

Inverse Time

One positive (51P), negative (51Q) and residual (51R) element each for both high side and low side windings are provided. A ground overcurrent element (51N) is provided for the low side winding.

Selectable curve shapes	Moderately inverse, very inverse, extremely inverse, IEC A, IEC B, IEC C, IEC D, IEC E, SEL-U1, SEL-U2, SEL-U3, SEL-U4, SEL-U5, User-defined
Pick-up range 51P and 51Q elements	0.1 to $90A_{\text{secondary}}$
Pick-up range 51R and 51N elements	0.05 to $90A_{\text{secondary}}$
Time Dial Setting range	0.1 to 15
Reset characteristic	Instantaneous or disk-like ²

OVEREXCITATION (24) PROTECTION

Overexcitation of a transformer will result in rapid overheating of the core due to saturation and may lead to severe damage of the transformer. The iXP-420 provides two levels of over-excitation protection.

² IEC curves are instantaneous reset only.

IDEA IXP-420 TRANSFORMER RELAY

Characteristic	Definite time or inverse
Pickup range	105 – 200%
Minimum Trip Time delay	0 – 3600 seconds
Inverse curve exponent	0.02 – 2.00
Reset time delay	0 – 3600 seconds

FREQUENCY ELEMENTS

The iXP-420 features frequency load shedding and restoration logic equipped with five levels of underfrequency load shedding elements. These elements may be used for transformer protection or to manage the shedding and restoration of multiple feeders within the substation. The elements may also be used in combination to perform both duties. Each underfrequency element, 81U1 through 81U5, may be separately enabled and selected to be either Protection or Load Shed elements.

Protection Mode: If the Mode is set to Protection, when the element trips the high and or low side breaker operates as determined by the Breaker Trip Control settings.

Load Shed Mode: If the Mode is set to Load Shed, when the element trips it operates a matching signal in the *IDEA Workbench*. These signals can be programmed by the user in the *IDEA Workbench* to operate output contacts for tripping and closing individual feeders within the substation. If frequency restoration is enabled, then these signals drop out once the frequency restoration conditions are met.

For restoration, a complete set of integrated timers is provided to allow for both scheduled restoration and the ability to ride through the momentary frequency excursions that occur during a system-wide restoration.

Pickup range for each 81 element	45 – 65Hz in 0.01Hz increments
Time delay	0 – 3600 seconds

VOLTAGE ELEMENTS

Numerous phase, zero sequence and negative sequence overvoltage elements. Typical applications include transformer overvoltage, bus overvoltage and open phasing protection. Phase undervoltage elements are also provided.

Overvoltage Elements (59-1, 59-2)

Two levels overvoltage protection are provided.

Pickup range	1 – 300 V _{secondary}
Time delay	0 – 3600 seconds

Undervoltage Elements (27-1, 27-2)

Two levels of undervoltage protection are provided.

Pickup range	1 – 300 V _{secondary}
Time delay	0 – 3600 seconds

Negative Sequence Overvoltage Element (59Q)

Pickup range	1 – 300 V _{2-secondary}
Time delay	0 – 3600 seconds

Zero Sequence Overvoltage Element (59N) (Requires L-G connect VTs)

Two levels of neutral overvoltage protection are provided.

Pickup range	1 – 300 V _{3V0-secondary}
Time delay	0 – 3600 seconds

SELECTIVE BREAKER TRIPPING

The iXP-420 is designed to operate low and or high side circuit breakers. Each protective element is configured to trip one or the other or both. This allows for greater flexibility in using the iXP-420 in a wide variety of substation bus configurations. Additionally, each protective element can be left “running” but not be assigned to operate either breaker. This allows the element’s output signal to be used in the *IDEA Workbench* for designing advanced protection and control schemes.

METERING

The iXP-420 offers extensive metering capabilities, including:

- Instantaneous Volt, Amp, Watt, VARS, PF in both primary and secondary scaled values.
- Demand metering
- Energy metering
- Harmonics metering (through the 15th) including THD for all voltage and all current channels.

EVENT RECORDS AND ANALYSIS TOOLS

The iXP-420 shares the same event records and analysis tools as all Edison Idea relays. The Edison Idea relay allows for the display of event records in a variety of formats including waveforms (oscillography), magnitude plots, phasor diagrams, symmetrical component diagrams and more. ProView, the software for the Edison Idea relay also provides a unique Application Diagram View that provides a one-screen view of everything that is going on in the relay. Many of these event views are also available in On-Line View mode, where it is possible to monitor the status of the relay in real-time.

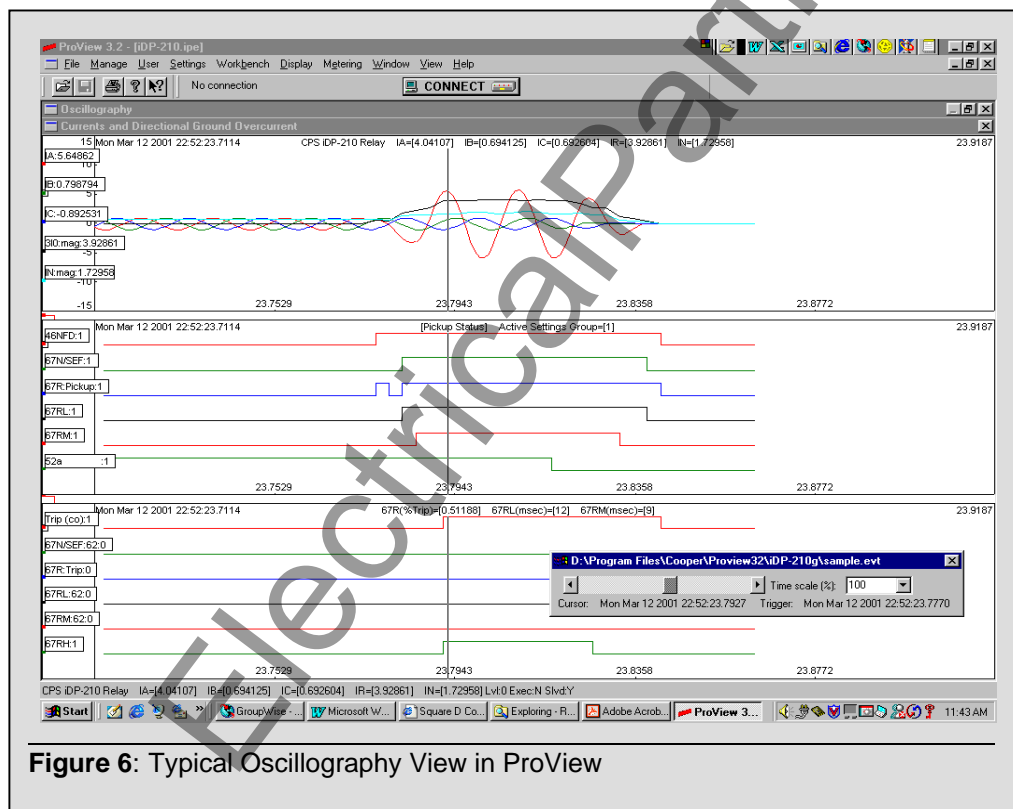

Figure 6: Typical Oscillography View in ProView

Relay Replay™³

To evaluate the effect different settings would have on the relay, the Relay-Replay feature of the Edison Idea software allows the user to make any number of setting changes and replay an existing event using these new settings without the need for an actual relay or expensive test equipment. The operation of every aspect of the relay’s performance, from which elements pick-up to the response time of those elements that do can be observed. This tool provides unprecedented “what-if” analysis capabilities.

Through Fault Monitoring

The elevated currents and associated heating of through faults shortens the life of a protected transformer. By monitoring the magnitude, duration and quantity of through faults a user can better schedule needed transformer maintenance.

Sequence of Through Fault Events

[Note: Current in Pri A, duration in mSec, Accumulated ISQT in KA*KA*Sec]

Y/M/D	H:M:S.ms										
Evt	Date	Time	Type	Max IA	ISQT_A	Max IB	ISQT_B	Max IC	ISQT_C	Durabo...	Counter
001	06/01/05	15:21:02.817	ALARM PHASE B	8034	999	7990	899	4	802	2982	9
002	06/01/05	15:21:02.210	THR FAULT ENDS	8034	999	7990	899	4	802	2982	9
003	06/01/05	15:20:21.115	THR FAULT ENDS	67	806	9991	709	84	802	999	8
004	06/01/05	15:15:41.696	ALARM PHASE C	108	806	134	609	9989	802	996	7
005	06/01/05	15:15:41.367	THR FAULT ENDS	108	806	134	609	9989	802	996	7
006	06/01/05	15:15:33.813	THR FAULT ENDS	60	806	10160	609	73	703	999	6
007	06/01/05	15:15:26.716	ALARM PHASE A	10045	806	129	506	68	703	1000	5
008	06/01/05	15:15:26.218	THR FAULT ENDS	10045	806	129	506	68	703	1000	5
009	06/01/05	15:15:18.613	THR FAULT ENDS	8034	705	7991	506	57	703	2987	4
010	06/01/05	15:15:08.801	THR FAULT ENDS	8037	513	133	315	7988	703	5997	3
011	06/01/05	15:14:56.205	THR FAULT ENDS	65	125	7994	315	7990	320	2996	2
012	06/01/05	15:14:46.641	THR FAULT ENDS	5020	125	4994	124	5090	129	4990	1
013	06/01/05	15:13:53.970	THR FAULT RESET	0	0	0	0	0	0	0	0

Go Offline Clear Write to file... OK [Volts and Amps in Primary Quantities]

Virtual Test Set™ (VTS™)

To evaluate settings against any arbitrary fault, the Edison Idea software permits the user to create a virtual event record through use of the software's VTS feature. The VTS allows complete control over:

- Pre-fault and post-fault voltage and current levels.
- Selection of phase-ground, phase-phase, phase-phase-ground and three phase fault types.
- Fault duration.
- Secondary fault impedance.
- Fault location (secondary side or internal).
- Differential current magnitude during the fault.
- Magnitude of restraint current.
- Selection of DC time constant.
- Control of frequency change, rate of change and acceleration during faults.
- Control over simulated breaker open and close times.

BREAKER HEALTH MONITORING

To assist in preventative maintenance programs, the iXP-420 monitors a number of critical breaker statistics. These include the circuit breaker's average, maximum and most recent closing and opening times, the accumulated interrupted current and breaker fail-to-trip, slow-to-trip, fail-to-close and slow-to-close conditions.

COMMUNICATIONS

Both Modbus RTU and DNP 3.0 communication protocols are included with the iXP-420. A Communications Workbench™ is provided which provides the user the ability to customize communication maps, add or delete information, add control points, and even create new signals to be brought out through communications. The iXP-420 features three auto-baud (57,600 kbps max) communication ports, two RS-232 and one RS-485. DNP TCP/IP is available with Ethernet ordering options including copper, multimode fiber, single mode fiber or some combinations of each.

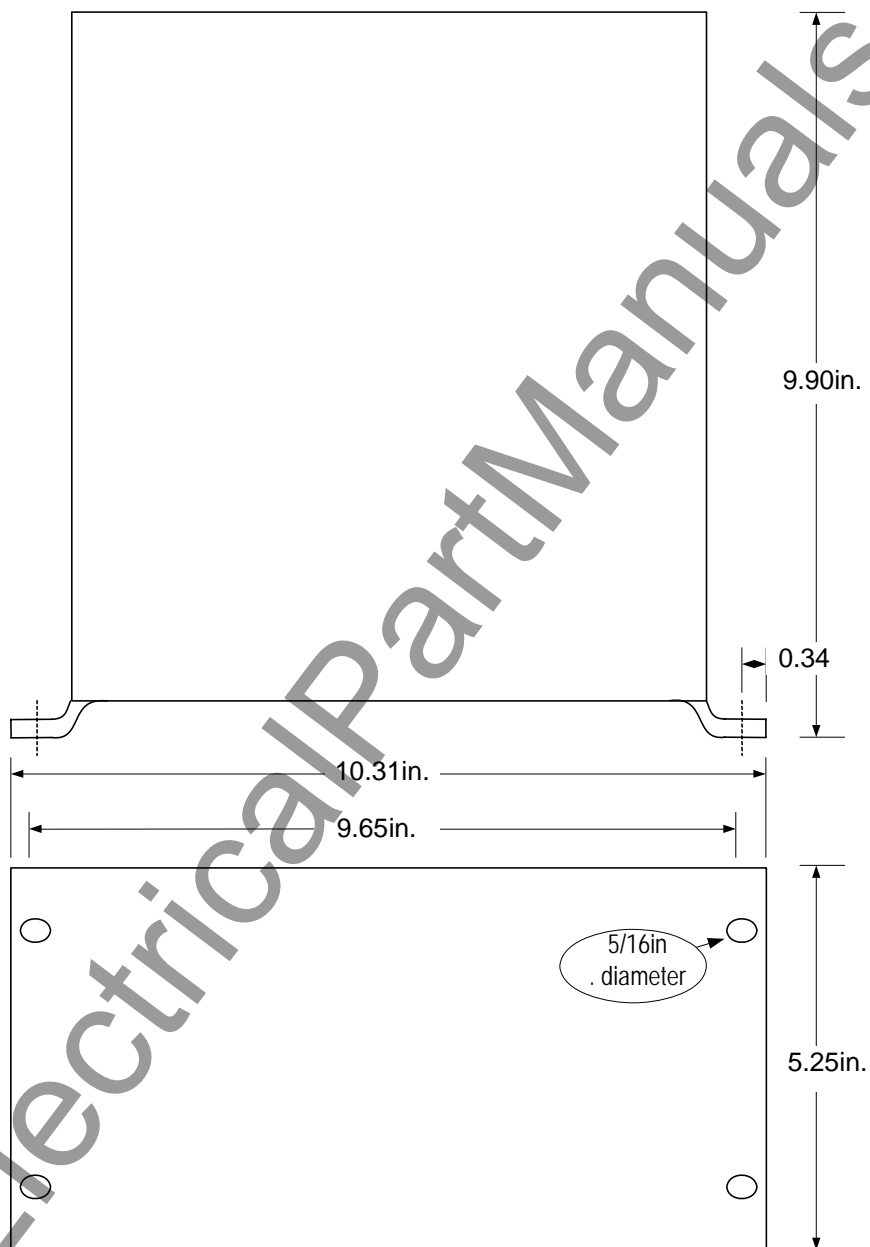

Figure 7: Edison Idea Relay Outline Dimensions (inches)

IDEA iXP-420 TRANSFORMER RELAY

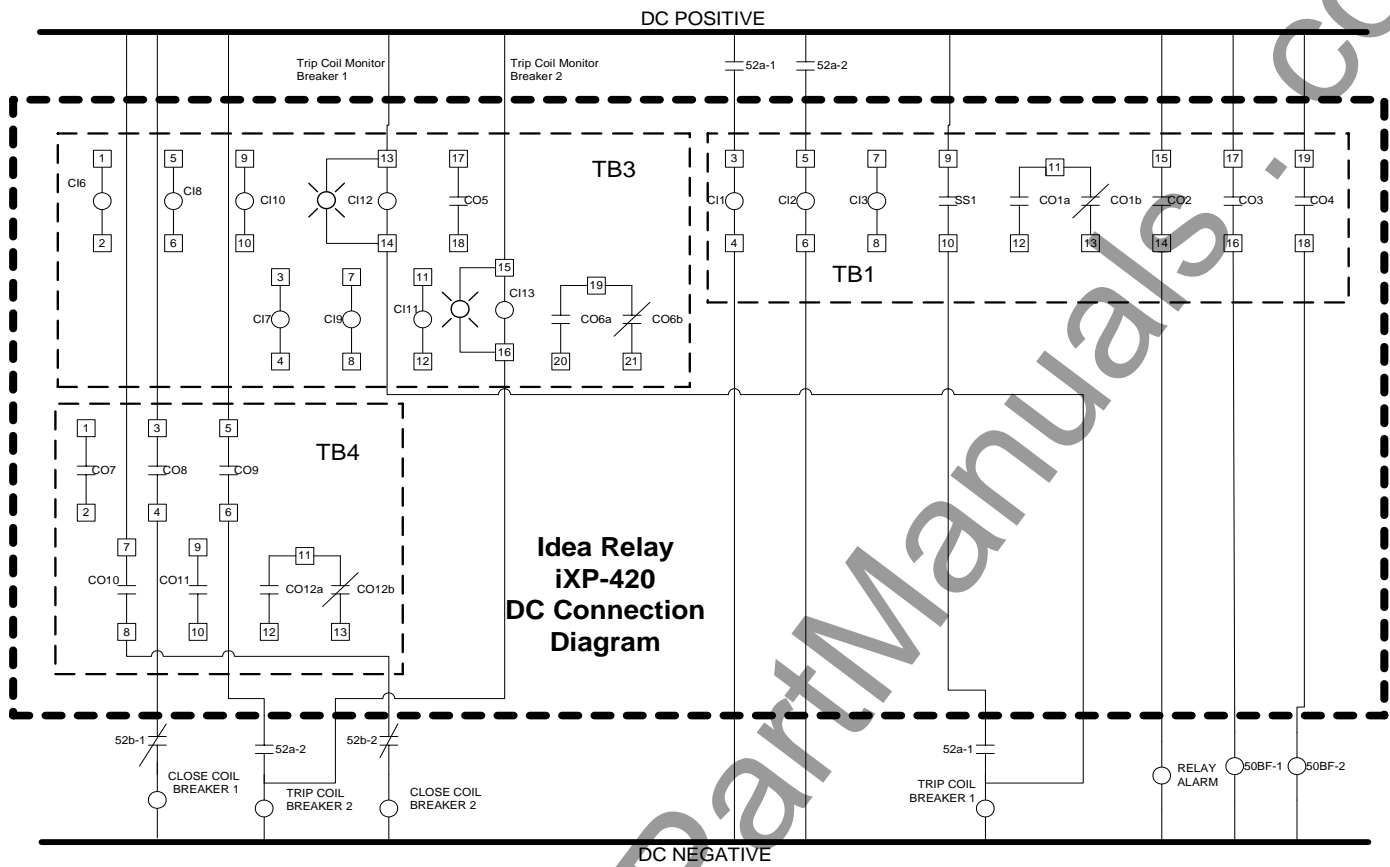

Figure 8: Typical iXP-420 DC Wiring Diagram for Idea Hardware

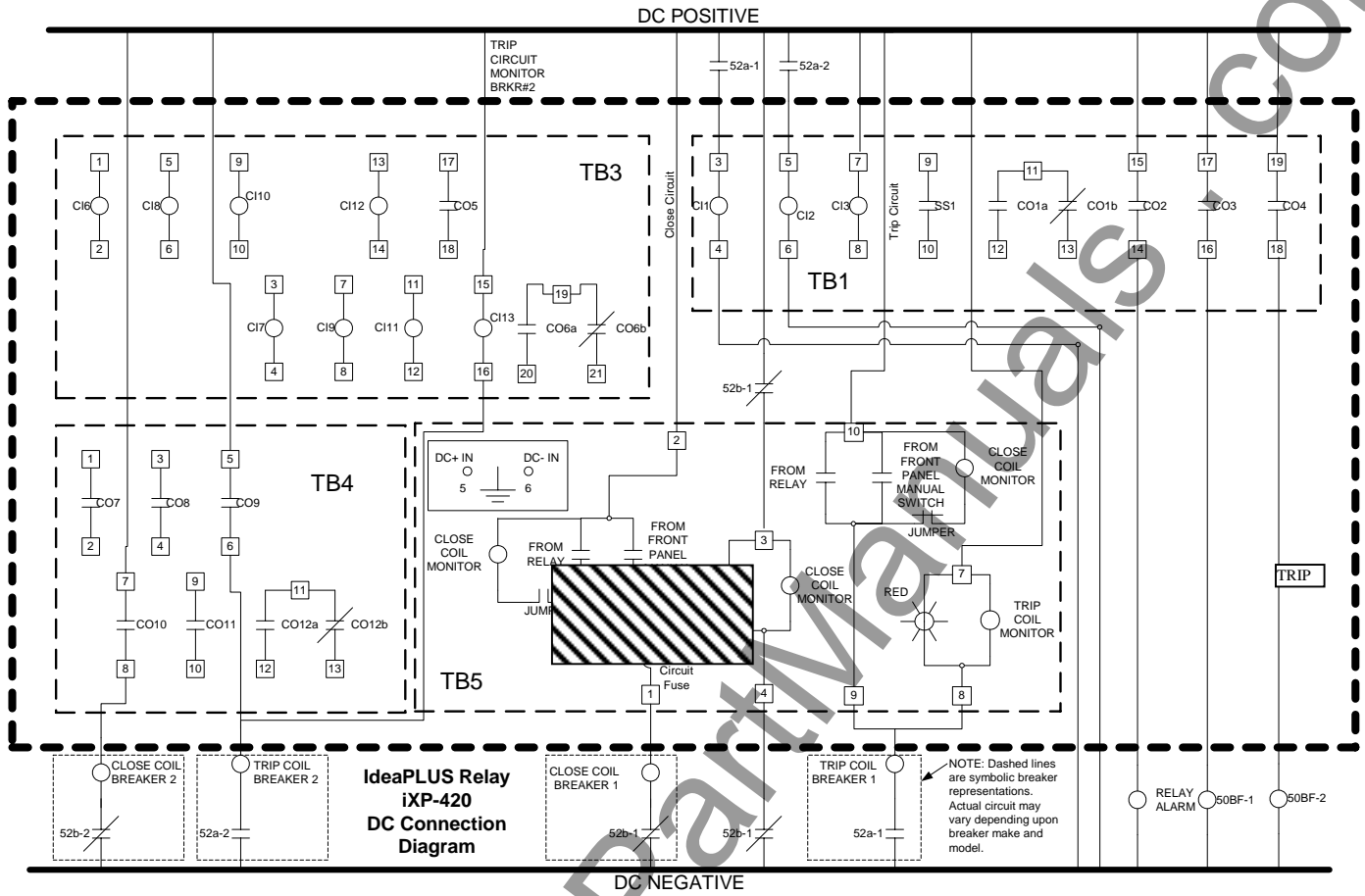

Figure 9: Typical iXP-420 DC Wiring Diagram for IdeaPLUS Hardware

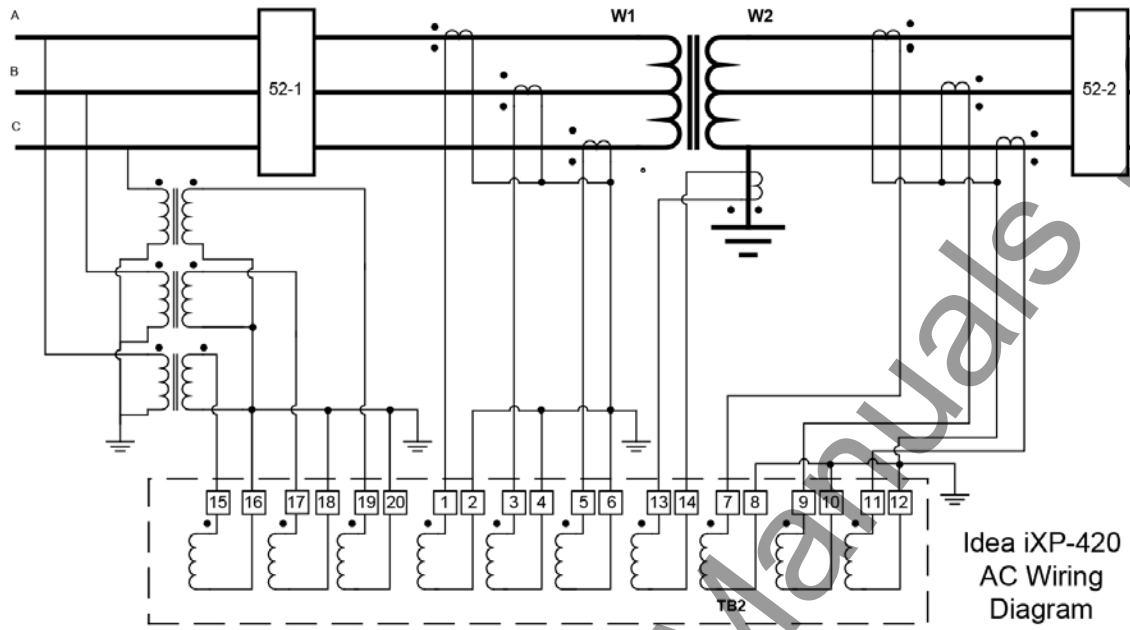

Figure 10: iXP-420 AC Wiring Diagram

Table 1 – Ordering Options

NOTE: Tagging and Lamp Style options (columns J and K) apply only to IdeaPLUS part numbers.

Construct Catalog Number from this table.

Sample Catalog Number:

A	B	C	D	E	F	G	H	I	J	K
Idea and IdeaPlus									IdeaPlus	
Product	Enclosure	Scheme	Language	Power	Input Range	Protocol	Aux I/O	TermBlk	Tagging	Lamp Style
PR6										

PR6 P2 X20 E 1 5 D 0 S C 3

<i>TYPE</i>	Edison Idea/IdeaPlus Relay Edison Idea Chassis Edison IdeaPlus Chassis	PR6 D2 P2								
<i>Scheme</i>	iXP – 420 Transformer Differential Relay		X20							
<i>Inserts Language</i>	English Portuguese Spanish Other			E P S O						
<i>Power</i>	48VDC Power Supply 125VDC/120VAC Power Supply 250VDC/240VAC Power Supply Other				4 1 2 X					
<i>Input Ranges</i>	5 Amp CT Inputs, 67/120V PT Inputs 1 Amp CT Inputs, 67/120V PT Inputs					5 1				
<i>Comm. Protocol</i>	RS 485 Fiber Serial Ethernet: Multimode Fiber MTRJ/MTRJ Ethernet: Multimode Fiber MTRJ/ Wire RJ 45 Ethernet: Wire RJ45/RJ45 Standard: None Ethernet: Single Mode Fiber LC/LC						1 3 4 5 6 7 8			
<i>Aux I/O</i>	Add 8 Contact Inputs and 8 contact outputs, all N.O. Add 8 Contact Inputs and 8 contact outputs, 1 NC, 7NO (not available with 24VDC power supply) Add 8 Contact Inputs and 8 contact outputs, 2 NC, 6NO (not available with 24VDC power supply) Add 8 Contact Inputs and 8 contact outputs, 3 NC, 5NO (not available with 24VDC power supply)						0 1 2 3			
<i>Term.</i>	All Barrier All Compression							S C		
<i>Tag Type</i>	Software based Close-inhibit, CLOSE inhibited on relay fail Software based Close-inhibit, CLOSE enabled on relay fail								C R	
<i>Trip/Close Lamp Type</i>	24 VDC LED Lamps for Trip and Close Status 24 VDC Incandescent Lamps for Trip and Close Status 48 VDC LED Lamps for Trip and Close Status 48 VDC Incandescent Lamps for Trip and Close Status 125VDC/120VAC LED Lamps for Trip and Close Status Other No Bulbs									1 6 2 7 3 X 0

Accessories:	Description	Catalog Number
	19" rack mount panel adapter for Idea relay	PR6DRP
	19" rack mount panel adapter for IdeaPLUS relay	PR6PRP
	19" 2-relay side-by-side 19" rack mount adapter for Idea relay	PR6ADRPDR
	19" 2-relay side-by-side 19" rack mount adapter for IdeaPLUS relay	PR6APRPDR
	6 foot (2m) front panel RS232 cable	KM5-665

IDEA IXP-420 TRANSFORMER RELAY

Specifications

Frequency	50/60 Hz
Voltage Inputs	Three voltage input channels 50 – 250 VAC continuous (phase-to-neutral) Burden < 0.1VA at 120V Primary DC Resistance 1,454Ω Error % < 0.3% over operating temperature
Current Inputs	Seven current input channels $I_{Nominal} = 5A$, $I_{continuous} = 15A$, $I_{3sec} = 150A$, $I_{1sec} = 300A$ Range of overcurrents settings 0.1 A to 90 A Step size 0.01 A Burden < 0.2VA at 5A Primary DC Resistance 3.4 mΩ Error % < 0.3% over operating temperature $I_{Nominal} = 1A$, $I_{continuous} = 3.2A$, $I_{3sec} = 30 A$, $I_{1sec} = 100A$ Range of overcurrents settings 0.02 A to 18 A Step size 0.002 A Burden < 0.2VA at 1A Primary DC Resistance 52.1 mΩ Error % < 0.3% over operating temperature
Digital Inputs (Optically Isolated)	9 – 150 VDC [24 VDC power supply] 36 – 150 VDC [48 VDC power supply] 90 – 300 VDC [120 VAC / 125 VDC power supply] 165 – 300 VDC [240 VAC / 250 VDC power supply] Nominal current draw of 2.5 mA, minimum operating time of 15 msec
Relay Outputs	240 Vac / 250 Vdc. Make: 30A for 0.2 seconds; Carry: 6A continuous. Break: 0.2A (L/R = 40 ms) Pickup time: <8ms; Dropout time: <5ms
Solid-State Outputs	240 Vac / 250 Vdc; Make: 30A for 0.2 seconds; Carry: 8A continuous. Break: 10A (L/R = 40 ms) Pickup time: <1ms; Dropout time: <15ms
Power Supply	24 VDC ± 20% 48 VDC ± 20% 120 VAC / 125 VDC ± 30% 240 VAC / 250 VDC ± 20% Burden: 14W
Local/Remote communications	EIA-RS-232C: 1 ea. located on front and rear panel Baud Rates: Auto baud rate up to 115,200 bps IRIG-B: 1 located on rear panel Optional Comm. Daughterboards (available with ProView 4.0.1): RS-485 (DC isolated) Modbus 57,600 bps; DNP 38,400 bps Serial Fiber Optic (ST) Ethernet, Multi-Mode, Fiber Optic (MTRJ/MTRJ) Ethernet, Multi-Mode, Fiber Optic / Wire (MTRJ/RJ45) Ethernet, Multi-Mode, Wire (RJ45/RJ45) Ethernet, Single-Mode, Fiber Optic (LC/LC)

Front Panel Targets	23 Programmable LEDs
Front Panel Display	20 x 4 character LCD
Front Panel Keypad	8 fixed-function keys, 4 multi-function "soft" keys 8 programmable "Hot-Keys"
Dimensions	Idea relay: 3 U high by 8.5" wide; 19" rack mount adapter plates and side by side mounting kits available
Relay Weight	10 lbs (4.5 kg) – Idea; 15 lbs (6.8 kg) – IdeaPlus;
Mounting	Horizontal
Operating Temperature	-40 °F to 158 °F (-40°C to 70 °C) continuous
Bump & Shock Test	IEC 60255-21-2 (1988) Class 1
Cold Temperature Test	IEC 60068-2-1 (1993) 16 hours at -40C
Electrostatic Discharge	EN 61000-4-2 (2001) Levels 1, 2, 3, and 4.
High temperature Test	IEC 60068-2-2 (1993) 16 hours at 70C
Humidity Test	IEC 60068-2-30 (1999) 25C to 55C, 95% Humidity, 2 cycles
Impulse/Dielectric Withstand	IEC 60255-5 (2000) Impulse Test: 5kV, 1.2 μ s rise time, half wave 50 μ s. Applied 3 impulses at each polarity. Dielectric: 3150 VDC for 1 minute. Insulation Resistance: Greater than 10 Gigaohms.
Radio Frequency Interference	Radiated: EN 61000-4-3 (2001) 20 MHz – 1 GHz, Idea 35 V/m and IdeaPlus 20 V/m. ANSI/IEEE C37.90.2 (1995) 35V/m from 20 MHz to 1 GHz Conducted: IEC 61000-4-6 (2001) 150 kHz – 80 MHz, 10 Vrms IEC 61000-4-16 (2001) 15 Hz – 150 kHz, 10 Vrms
Surge Withstand	ANSI/IEEE C37.90.1 (2002) 2.5 kV oscillatory, \pm 4 kV fast transient
Vibration Test	IEC 60255-21-1 (1988) Class 1
Contact Rating	ANSI/IEEE C37.90, Section 6.7 (1989) 30A for 0.2 seconds, 2000 operations, at 125 VDC, 250 VDC, and 240 VAC.
Object Penetration	IEC 60529 (2001-02) IP3X rating
Emissions	EN 55022, Class A, Radiated and Conducted
Conducted Disturbances	IEC 6100-4-6 (150kHz – 80 MHz)

Specifications subject to change without notice.

www.ElectricalPartManuals.com

Edison is a registered trademark of Cooper Power Systems, Inc., or its affiliates.
ProView, Idea, Idea Workbench, Virtual Test Set, VTS, and Relay-Replay are trademarks
of Cooper Power Systems, Inc., or its affiliates.

Microsoft Windows is either a registered trademark or trademark of Microsoft Corporation
in the United States and/or other countries.

