

iCP-440 Capacitor Bank Protection Relay

165-440-900



Figure 1: Edison Idea Relay

The iCP-440 capacitor bank protection relay is a member of Cooper Power Systems' Edison[®] Idea[™] line of protective relays. The iCP-440 is a full-featured relay suitable for shunt capacitor or filter bank protection and automatic voltage control applications. The relay is ideally suited for new or retrofit applications of fuseless or internal/externally fused banks requiring neutral unbalance protection. It utilizes voltage or current neutral unbalance to provide flexible protection for both grounded and ungrounded banks. Single or double wye bank configurations may be accommodated. The relay easily permits nulling of inherent bank unbalance and compensates for real time system unbalances (single wye) thus permitting maximum sensitivity for detection of internal problems. The relay detects capacitor unit failure when the compensated neutral quantity increases beyond a threshold. The neutral unbalance algorithms permit secure and economical protection on banks of various var ratings. The iCP-440 also provides advanced power quality, metering, communication, and PLC functions.

The iCP-440 uses Cooper Power Systems' ProView[™] interface software package for PCs running the Microsoft[®] Windows[®] operating system. Via the *IDEA Workbench[™]* feature of ProView, add additional functionality to the iCP-440 by means of downloadable Custom Modules obtained from Cooper Power Systems. Provide custom solutions by employing the Workbench's intuitive and graphical tools for creating, viewing and testing logic diagrams. This expandability provides a continuous upgrade path that not only protects the initial investment in the relay but also provides a means to increase the relay's functionality in response to changing protection requirements and regulatory, power quality and reliability concerns.

February 2007 • Supersedes November 2006

PROTECTION AND CONTROL FUNCTIONS

Unbalance detection of grounded or ungrounded capacitor or filter banks using compensated neutral current (50N) or voltage (59N).

Three-phase definite-time and inverse-time overcurrent fault protection (50P, 51P).

Residual definite-time and inverse-time overcurrent ground fault protection (50R, 51R).

Phase and neutral rms, definite-time reactor / resistor over load protection (50OL, 50NOL).

Definite time overvoltage alarming, tripping and inverse time overvoltage protection (59-A, 59-T, 51V).

Definite time undervoltage (27); Dead Bus Trip (DBT).

Block of Close following Trip Lockout or awaiting discharge.

Fuse Fail (Loss of Voltage) detection (27FF).

Automatic voltage control.

Breaker Failure.

ADVANCED CAPABILITIES

Add new functions and features using *IDEA Workbench[™]* Custom Modules.

Virtual Test Set[™]: Pre-test relay protective responses and custom logic interaction using the powerful simulation module built into the Proview software.

Relay Replay[™]: Anticipate future changes to the protection environment based on historical oscillographic event data.

Metering of Amps, Volts, Vars, etc: Accurately quantify system and bank health via important analog data.

Sequence of Events: Quickly access logged relay responses to system or human activity via the front panel display or uploaded files.

Data Profiler: Time-trend harmonic levels in and around the bank. Tailor the Profiler to trend the data important to you.

ProView's relay scheme file completely documents protection and control algorithms via interactive logic diagrams; these are color-coded and come alive when viewing historical, on-line, or simulated data.

Dual ports Ethernet: Easily integrate the relay into your communication network.

CUSTOMIZE THE iCP-440 WITH THE *IDEA WORKBENCH*™

The iCP-440 is a fully functional relay, ready to use right out of the box. However, there are applications where custom control logic, or custom functions need to be added to the relay. The *IDEA Workbench* is a revolutionary graphical software-programming environment provided by ProView that permits the user to customize the iCP-440.

- Add new features or protective functions by means of *IDEA Workbench* Custom Modules; e.g., bank switching based on time of day or season. Through these, your investment in the relay is protected as future needs and developments are addressed.
- Create custom control and protection logic using over 400 programming signals and tools, all selectable from drag-off Toolboxes. Logic created using these tools can then be saved as Custom Modules to be reused or shared with associates.

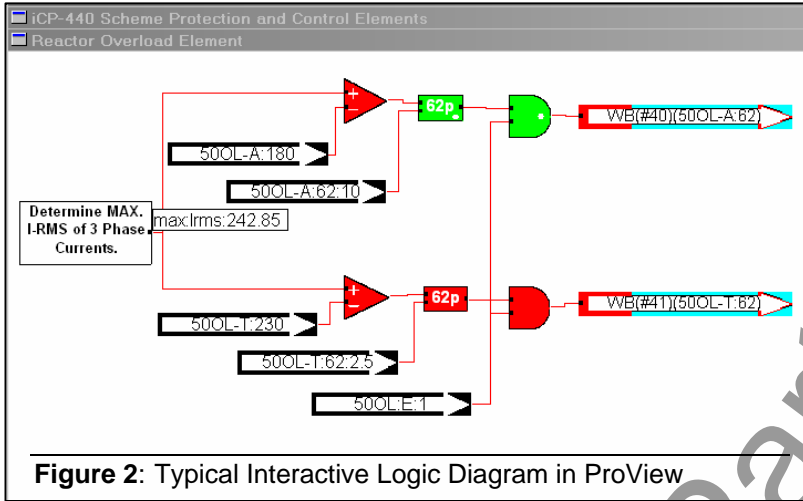

- Monitor and control practically every aspect of the relay's operation with interactive logic diagrams. See Figure 2. View the layout of protection and control logic diagrams via the graphical interface software; observe actual binary status or analog data values while "On Line", playing back events or in simulation mode.
- Create custom metering and measurement quantities and application-specific sequence of event records and data profiling.
- Configure communication protocols. Alter protocol type, ports, data rates and input / output mapping to match the needs of the application.

Use the *IDEA Workbench* to rapidly and accurately create customized solutions by working the way the engineer thinks, via logic diagram and flowchart construction methods in a graphical environment. No equation-based or command-based logic programming is required.

CAPACITOR BANK UNBALANCE PROTECTION USING NEUTRAL CURRENT (50N) OR VOLTAGE (59N), SINGLE OR DOUBLE WYE CONFIGURATION

Using well-proven neutral unbalance capacitor bank protection principles, the iCP-440 is applicable regardless of bank grounding (ungrounded, solid or resistive / capacitive), capacitor unit fusing (external, internal or fuseless), wye configuration (single or double), or system voltage or bank var rating. Multiple levels of unbalance alarm and trip protection are provided. The inherent neutral unbalance quantity is committed to relay memory at commissioning time to compensate for capacitor tolerances. For single wye configurations, input bus voltages permit the relay to compensate for system voltage unbalances. For double wye applications where ambiguous indications are a concern, additional logic tracks self-canceling can failures by preventing similar capacitor failures in both sides of the same phase from re-balancing the neutral signal. Together, these advanced features offer to the iCP-440 user ultimate sensitivity and permit detection of the smallest number of unit failures within the bank.

OVERCURRENT PROTECTION

The iCP-440 eliminates the need for additional relays by offering complete backup definite-time and inverse-time overcurrent protection for both phase and ground faults. The inverse-time response follows IEEE, IEC or industry standard characteristic curves.

OVERLOAD PROTECTION

Series-connected inrush or harmonic tuning reactors are susceptible to thermal effects due to harmonic-rich bank currents. Use the iCP-440's true rms current sensing definite-time phase element to aid in harmonic overload alarm and trip protection of any reactors connected. Enable the relay's built-in neutral overload element to prevent excessive thermal stress in neutral-ground connected components, e.g., a capacitor bank neutral resistor.

UNDER, OVERVOLTAGE PROTECTION

The protection response characteristic follows a piece-wise linear curve based on the IEEE STD-18 overvoltage / time point pairs. The rated voltage of the capacitor bank is the only setting for this simple but effective protective element. The inverse time overvoltage element adjusts for any voltage drop across an inrush or tuning reactor. Select between three methods to calculate equivalent capacitor voltage: Root Sum of Squares (RSS), Arithmetic Summation (Asum) or direct phase voltage inputs. The iCP-440 also provides definite-time overvoltage alarming and undervoltage trip protection.

VOLTAGE CONTROL

Use the iCP-440 to automatically control bus voltage by selectively operating the bank's switching device based on adjustable voltage profile thresholds and time delays. Use maximum / minimum per-phase voltage values, positive sequence magnitude, or a user-defined analog value as the controlling signal. If necessary for the application, Workbench customization permits additional switching control based on time-of-day, day-of-week, season-of-year or other criteria determined by the user. Augment the real-time control via SCADA as needed.

DEAD BUS TRIP (DBT)

If the capacitor bus becomes inadvertently de-energized, e.g., due to tripping of line breakers in response to a system fault, the DBT element may trip off the capacitor bank prior to any auto-reclosing. This prevents the occurrence of damaging electrical transients associated with re-energizing capacitor banks still containing trapped charge.

BLOCK OF CLOSE

Re-energization of capacitor banks with trapped charge causes transient overvoltages. The iCP-440 has logic implemented with user-settable time delays to allow decay of the trapped charge.

METERING

The iCP-440 offers extensive and high accuracy metering capabilities, including:

- Instantaneous Volt, Amp, Watt, vars and other quantities in primary scaled values.
- Demand metering with date/time stamped peak values.
- Harmonics metering (through the 15th) including THD for all voltage and all current channels.

EVENT RECORDS AND ANALYSIS TOOLS

The iCP-440 shares the same event recording and analysis tools as all Edison Idea relays. The Edison Idea allows for the display of event records in a variety of formats including waveforms (oscillography), magnitude plots, phasor diagrams, symmetrical component diagrams and more. Many of these event views are also available in On-Line View

mode, where it is possible to monitor the status of the relay in real-time. Convert event data to COMTRADE files if needed for subsequent analysis

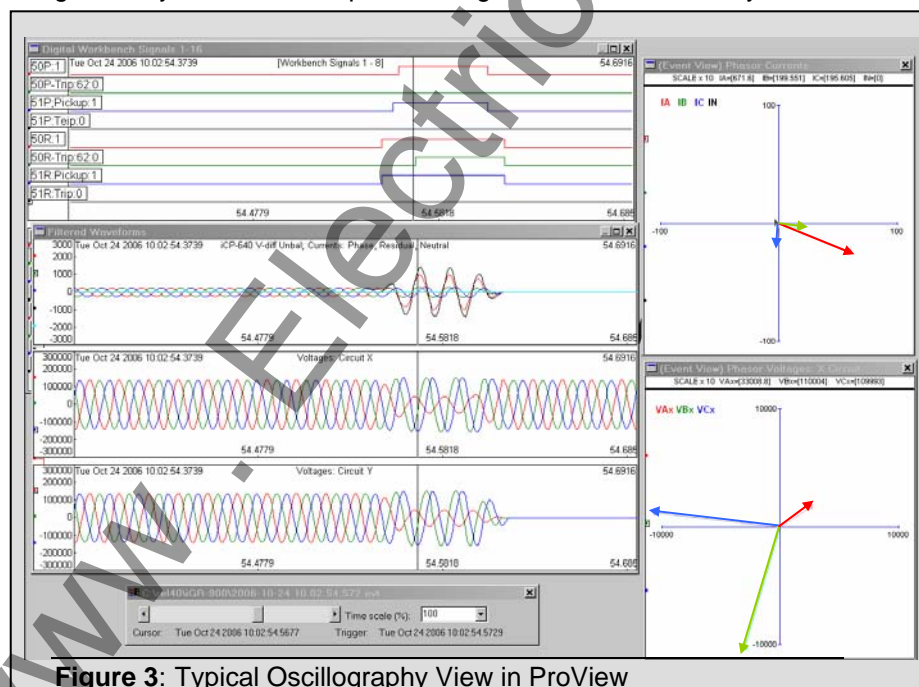

Figure 3: Typical Oscillography View in ProView

Relay Replay™

To evaluate the effect different settings would have on the relay, the Relay-Replay feature of the Edison Idea's ProView software allows the user to make any number of setting changes and replay an existing event using these new settings without the need for an actual relay or expensive test equipment. The operation of every aspect of the relay's performance can be observed: which elements pick-up what is the response time of those elements that do. This tool provides unprecedented "what-if" analysis capabilities.

IDEA iCP-440 Capacitor Bank Protection Relay

COMMUNICATIONS

Modbus RTU and DNP 3.0 (serial or TCP/IP) communication protocols are available. Customize communication maps, add or delete information, add control points, and even create new signals to be brought out through communications via various serial or Ethernet ports. See Table 1 – Ordering Options for details on available communication options.

HARDWARE DIMENSIONS

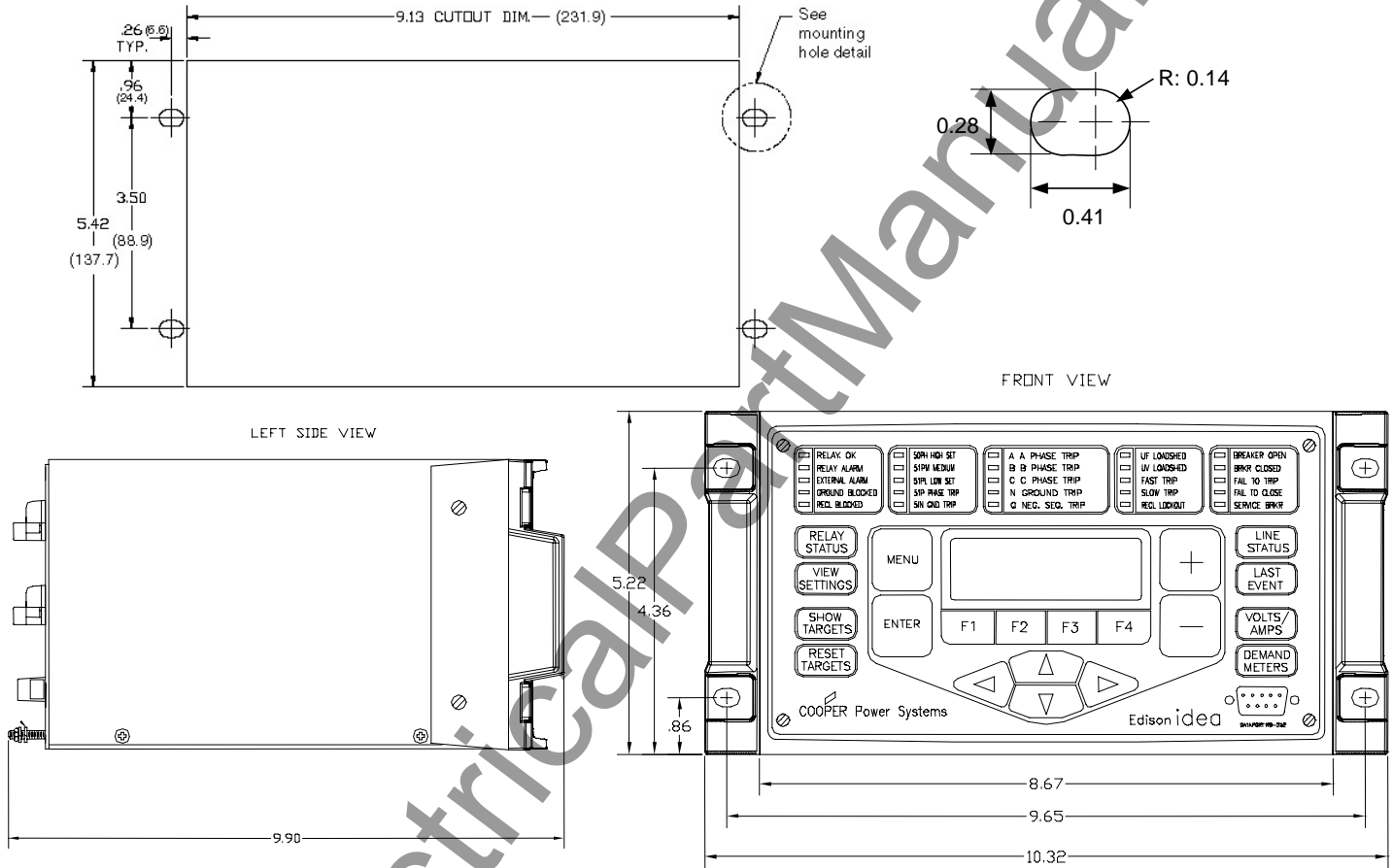

Figure 4: Edison Idea Relay Panel Cutout and Outline Dimensions in Inches (mm)

TYPICAL DC WIRING DIAGRAM

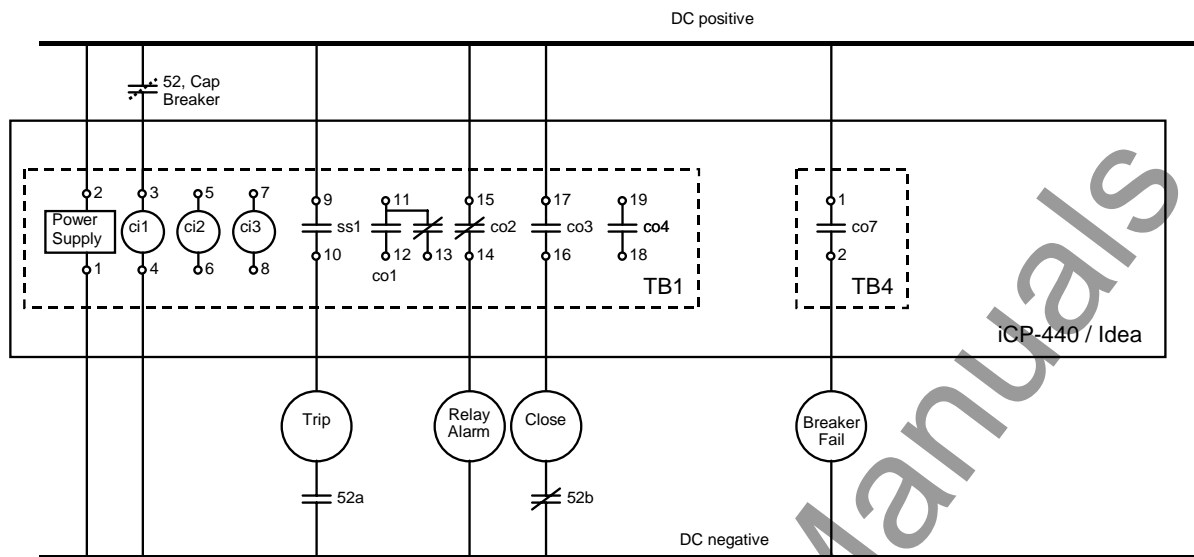

Figure 5: iCP-440 DC Wiring Diagram

AVAILABLE CAPACITOR UNBALANCE PROTECTION APPLICATION OPTIONS

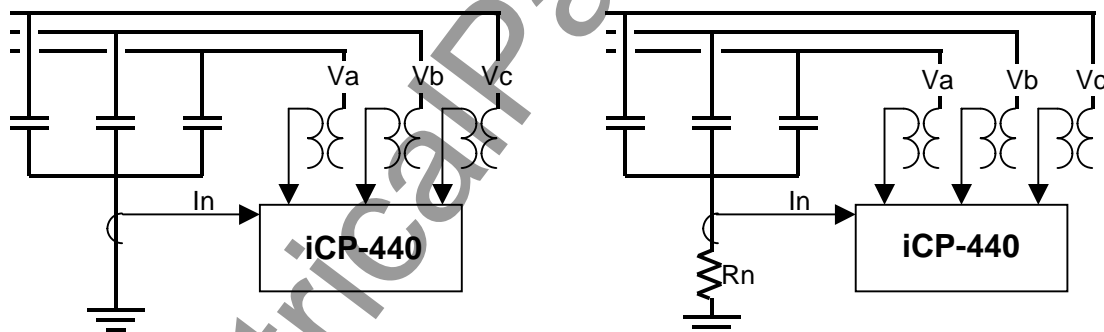

Figure 6: Single Wye, Neutral Current (3-phase overcurrent inputs not shown)

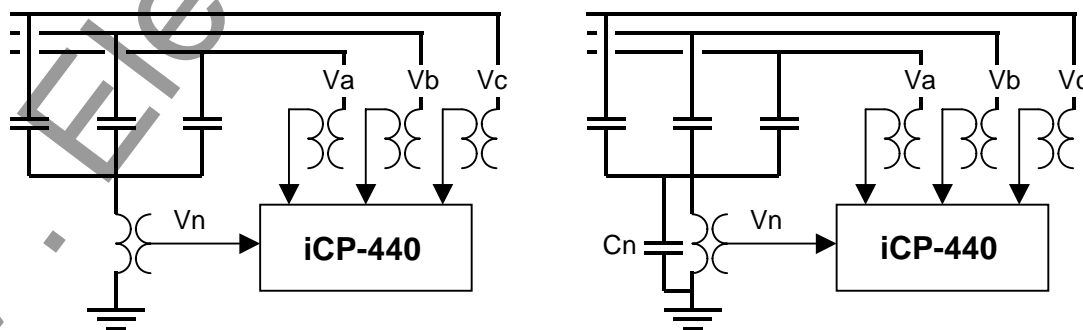

Figure 7: Single Wye, Neutral Voltage (3-phase overcurrent inputs not shown)

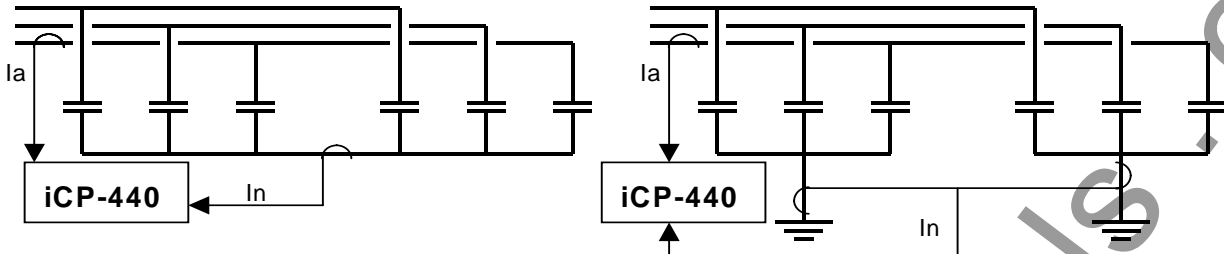

Figure 8: Double Wye, Neutral Current (3-phase overcurrent and voltage inputs not shown)

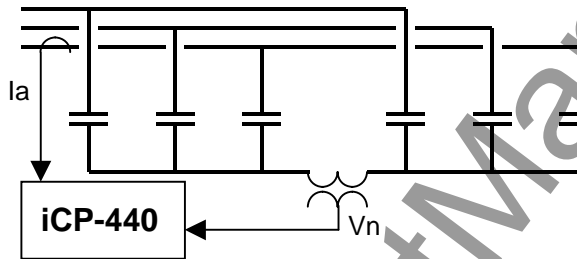

Figure 9: Double Wye, Neutral Voltage (3-phase overcurrent and voltage inputs not shown)

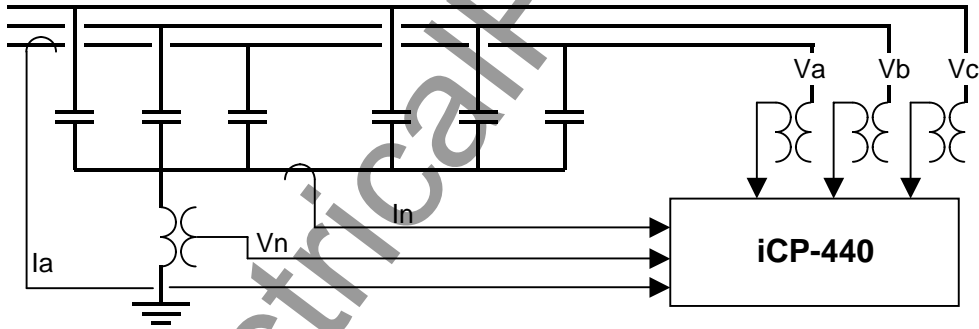

Figure 10: Double Wye, Neutral Voltage and Current (3-phase overcurrent inputs not shown)

Table 1 – Ordering Options

		A	B	C	D	E	F	G	H	I
		Idea								
		Product	Enclosure	Scheme	Language	Power	Input Range	CommOption	Aux I/O	TermBlk
		PR6	D2	C44						
		Sample Catalog Number: PR6 D2 C44 E 1 5 1 0 S								
<i>TYPE</i>	Edison Idea/IdeaPlus Relay Edison Idea Chassis	PR6								
<i>Scheme/</i>	ICP-440-900 neutral unbalance cap bank scheme		D2	C44						
<i>Inserts</i>	English				E					
<i>Language</i>	Portuguese				P					
	Spanish				S					
	Other				O					
<i>Power</i>	48VDC Power Supply					4				
	125VDC/120VAC Power Supply					1				
	250VDC/240VAC Power Supply					2				
	24VDC Power Supply					3				
<i>Input Ranges</i>	5 Amp CT Inputs, 67/120V PT Inputs						5			
	1 Amp CT Inputs, 67/120V PT Inputs						1			
<i>Comm. Options</i>	RS485							1		
	Fiber serial							3		
	Ethernet Fiber Optic:Fiber Optic MTRJ/MTRJ							4		
	Ethernet Fiber Optic:Wire MTRJ/RJ45							5		
	Ethernet Wire:Wire RJ45/RJ45							6		
	Standard: None							7		
	Ethernet Single Mode Fiber LC/LC							8		
<i>Aux I/O</i>	Select 8 Contact Inputs and 8 Contact Outputs, all N.O								0	
	Select 8 Contact Inputs and 8 Contact Outputs, 1 NC, 7NO								1	
	Select 8 Contact Inputs and 8 Contact Outputs, 2 NC, 6NO								2	
	Select 8 Contact Inputs and 8 Contact Outputs, 3 NC, 5NO								3	
<i>Term.</i>	All Barrier									S
	All Compression									C

Relay Accessories

Description	Catalog Number
19" rack mount panel adapter for Idea relay	PR6ADRP
19" 2-relay side-by-side mounting adapter for Idea relays	PR6ADJK
6 foot (2m) front panel RS232 cable	F500066001

IDEA iCP-440 Capacitor Bank Protection Relay

Specifications

Frequency	50/60 Hz
Voltage Inputs	Six voltage input channels; four used in the scheme 50 – 250 VAC continuous (phase-to-neutral) Burden < 0.1VA at 120V Primary DC Resistance 1,454Ω Error % < 0.3% over operating temperature
Current Inputs	Four current input channels $I_{Nominal} = 5A$, $I_{continuous} = 15A$, $I_{3sec} = 150A$, $I_{1sec} = 300A$ Range of overcurrents settings 0.1 A to 90 A Step size 0.01 A Burden < 0.2VA at 5A Primary DC Resistance 3.4 mΩ Error % < 0.3% over operating temperature $I_{Nominal} = 1A$, $I_{continuous} = 3.2A$, $I_{3sec} = 30A$, $I_{1sec} = 100A$ Range of overcurrents settings 0.02 A to 18 A Step size 0.002 A Burden < 0.2VA at 1A Primary DC Resistance 52.1 mΩ Error % < 0.3% over operating temperature
Digital Inputs (Optically Isolated)	9 – 150 VDC [24 VDC power supply] 36 – 150 VDC [48 VDC power supply] 90 – 300 VDC [120 VAC / 125 VDC power supply] 165 – 300 VDC [240 VAC / 250 VDC power supply] Nominal current draw of 2.5 mA, minimum operating time of 15 msec
Relay Outputs	240 Vac / 250 Vdc, Make: 30A for 0.2 seconds; Carry: 6A continuous. Break: 0.2A (L/R = 40 ms) Pickup time: <8ms; Dropout time: <5ms
Solid-State Outputs	240 Vac / 250 Vdc; Make: 30A for 0.2 seconds; Carry: 8A continuous. Break: 10A (L/R = 40 ms) Pickup time: <1ms; Dropout time: <15ms
Power Supply	24 VDC ± 20% 48 VDC ± 20% 120 VAC / 125 VDC ± 30% 240 VAC / 250 VDC ± 20% Burden: 14W
Local/Remote communications	EIA-RS-232C: 1 ea. located on front and rear panel Baud Rates: Auto baud rate up to 115,200 bps IRIG-B: 1 located on rear panel Optional Comm. Daughterboards (available with ProView 4.0.1): RS-485 (DC isolated) Modbus 57,600 bps; DNP 38,400 bps Serial Fiber Optic (ST) Ethernet, Multi-Mode, Fiber Optic (MTRJ/MTRJ) Ethernet, Multi-Mode, Fiber Optic / Wire (MTRJ/RJ45) Ethernet, Multi-Mode, Wire (RJ45/RJ45) Ethernet, Single-Mode, Fiber Optic (LC/LC)

Front Panel Targets	23 Programmable LEDs
Front Panel Display	20 x 4 character LCD
Front Panel Keypad	8 fixed-function keys, 4 multi-function "soft" keys 8 programmable "Hot-Keys"
Dimensions	Idea relay: 3 U high by 8.5" wide; 19" rack mount adapter plates and side by side mounting kits available
Relay Weight	10 lbs
Mounting	Horizontal
Operating Temperature	-40 °F to 158 °F (-40°C to 70 °C) continuous
Bump & Shock Test	IEC 60255-21-2 (1988) Class 1
Cold Temperature Test	IEC 60068-2-1 (1993) 16 hours at -40C
Electrostatic Discharge	EN 61000-4-2 (2001) Levels 1, 2, 3, and 4.
High temperature Test	IEC 60068-2-2 (1993) 16 hours at 70C
Humidity Test	IEC 60068-2-30 (1999) 25C to 55C, 95% Humidity, 2 cycles
Impulse/Dielectric Withstand	IEC 60255-5 (2000) Impulse Test: 5kV, 1.2 μs rise time, half wave 50 μs. Applied 3 impulses at each polarity. Dielectric: 3150 VDC for 1 minute. Insulation Resistance: Greater than 10 Gigaohms.
Radio Frequency Interference	Radiated: EN 61000-4-3 (2001) 20 MHz – 1 Ghz, Idea 35 V/m. ANSI/IEEE C37.90.2 (1995) 35V/m from 20 MHz to 1 GHz Conducted: IEC 61000-4-6 (2001) 150 kHz – 80 MHz, 10 Vrms IEC 61000-4-16 (2001) 15 Hz – 150 kHz, 10 Vrms
Surge Withstand	ANSI/IEEE C37.90.1 (2002) 2.5 kV oscillatory, ± 4 kV fast transient
Vibration Test	IEC 60255-21-1 (1988) Class 1
Contact Rating	ANSI/IEEE C37.90, Section 6.7 (1989) 30A for 0.2 seconds, 2000 operations, at 125 VDC, 250 VDC, and 240 VAC.
Object Penetration	IEC 60529 (2001-02) IP3X rating

Specifications subject to change without notice.

www.ElectricalPartManuals.com

www.ElectricalPartManuals.com

WWW.ElectricalPartManuals.COM

©2007 Cooper Power Systems, Inc., or its affiliates.
ProView, IDEA Workbench, User Workbench, Relay-Replay, and Virtual Test Set
are trademarks of Cooper Power Systems, Inc., or its affiliates.
Edison is a registered trademark of Cooper Power Systems, Inc., or its affiliates.

(Relay Replay United States Patent Number 5,878,375)

Microsoft® Windows® are either registered trademarks or trademarks of
Microsoft Corporation in the United States and/or other countries.