



# **INSTRUCTIONS**

---

**MULTI-CONTACT  
AUXILIARY RELAY**

**TYPE  
HFA54**

**GE Meter and Control  
205 Great Valley Parkway  
Malvern, PA 19355-0715**

[www.ElectricalPartManuals.com](http://www.ElectricalPartManuals.com)

CONTENTS

	<u>PAGE</u>
DESCRIPTION .....	3
APPLICATION .....	3
RATINGS .....	3
CHARACTERISTICS .....	4
BURDENS .....	6
RECEIVING, HANDLING AND STORAGE .....	7
INSTALLATION .....	7
PERIODIC CHECKS AND ROUTINE MAINTENANCE .....	7
SERVICING AND ADJUSTMENTS .....	8
CONTACT CLEANING .....	8
CONTACT ADJUSTMENT .....	8
PICKUP .....	9
RENEWAL PARTS .....	9

*These instructions do not purport to cover all details or variations in equipment nor provide for every possible contingency to be met in connection with installation, operation or maintenance. Should further information be desired or should particular problems arise which are not covered sufficiently for the purchaser's purposes, the matter should be referred to the General Electric Company.*

*To the extent required the products described herein meet applicable ANSI, IEEE and NEMA standards; but no such assurance is given with respect to local codes and ordinances because they vary greatly.*

MULTI-CONTACT AUXILIARY RELAY

TYPE HFA54

DESCRIPTION

The HFA54 relays are instantaneous, hinged-armature, multi-contact, electric-reset, auxiliary relays. Some of the models are also available with a hand reset feature in addition to the electric reset feature. They have five or six electrically-separate contact circuits adaptable for either circuit-opening or circuit-closing-applications.

The HFA relays are available for front or back connection. The front-connected relays are suitable for surface mounting only. The back-connected relays are suitable for either surface mounting or semi-flush mounting. Outline and panel drilling dimensions are shown in Figures 7-10. Internal connections for the relays are shown in Figures 4, 5, and 6.

APPLICATION

The HFA relays are electric-reset, hinged-armature, instantaneous auxiliary relays that are suitable for application where the operating characteristics and ratings as described in this book are required.

RATINGS

The TYPE HFA relays are available with coil ratings for standard voltages up to 575 volts at 25, 50 or 60 cycles, and up to 250 volts DC.

The operating coil is continuously rated but the reset coil has a five (5) second intermittent rating.

The current-closing rating of each contact is 30 amperes. The current-carrying rating is 12 amperes continuous or 30 amperes for one minute. Table I lists the non-inductive interrupting capacity of each contact.

TABLE I

DC		AC	
VOLTS	AMPERES	VOLTS	AMPERES
12	30	115	30
24	15	230	20
32	10	460	15
48	8	575	10
125	3		
250	1		

CHARACTERISTICS

The HFA54 relays are multi-contact auxiliary relays, some of them available with the additional feature of both electric and hand reset. The hand reset feature is accomplished with a plunger assembly installed through the transparent cover.

Some of the stationary contacts (called long wipe) are built with a special offset so that when a circuit-opening contact and circuit-closing contact are used as a pair, a make-before-break circuit results. The use of these contacts requires an additional strong contact spring to minimize contact bounce and ensure contact overlap. These contacts are designated as long-wipe contacts.

Unless the relays are ordered with a specific contact arrangement, they will be shipped with six (6) circuit-closing contacts (code 60). However, the HFA54D and HFA54K relays are available with contact code 33 only, as given in Table V.

The general characteristic of HFA54 relays are summarized in Table II.

TABLE II

Model No.	No. Separate Contact Circuits	Additional Characteristics	Contact Arrangement Table
HFA54B	5	Hand Reset	III
HFA54C	5	Hand Reset and Mechanical Target	III
HFA54D	5	Hand Reset with Overlapping Contacts in Positions 2 and 3	V
HFA54E	5	-----	III
HFA54H	6	Hand Reset	IV
HFA54J	6	Hand Reset and Mechanical Target	IV
HFA54K	6	Hand Reset with Overlapping Contacts in Positions 2 and 3	V
HFA54L	6	-----	IV
HFA54M	4	Relay Contact #3 Opens Operating Coil when Relay Picks Up	VI
HFA54N	4	Similar to 54M except with Additional Feature of Hand Reset	VI

TABLE III (HFA54B, C, E)

CODE NO.	60	51	42	33	24	15
POSITION NO.	CONTACT ARRANGEMENT					
1	a	a	a	a	a	b
2	a	a	a	a	b	b
3	a	a	b	b	b	b
4	a	b	b	b	b	b
5	a	a	a	b	b	b
+6	a	a	a	a	a	a

a = Normally Open  
 b = Normally Closed  
 + = Used to Open Reset Coil Circuit  
 a1 = Normally Open, Long Wipe  
 b1 = Normally Closed, Long Wipe

TABLE IV (HFA54H, J, L)

CODE NO.	60	51	42	33	24	15	06
POSITION NO.	CONTACT ARRANGEMENT						
1	a	a	a	a	a	b	b
2	a	a	a	a	b	b	b
3	a	a	b	b	b	b	b
4	a	b	b	b	b	b	b
5	a	a	a	b	b	b	b
6	a	a	a	a	a	a	b

TABLE V (HFA54D, K)

CODE NO.	33
POSITION NO.	CONTACT ARRANGEMENT
1	a
2	a <sub>1</sub>
3	b <sub>1</sub>
4	b
5	b
6 +	a

TABLE VI (HFA54M, N)

CODE NO.	1	2	3	4
POSITION NO.	CONTACT ARRANGEMENT			
1	a	a	a	a
2	a	a	b	a
3	b <sub>1</sub>	b <sub>1</sub>	b <sub>1</sub>	b <sub>1</sub>
4	a	b <sub>1</sub>	b	b
5	a	a	a	b
6	a	a	a	a

The HFA54N is similar to the HFA54M except that it has an additional feature of hand reset. The internal connections diagram of the HFA52M and HFA54N shows an external capacitor connected in parallel with the operating coil and an external resistor connected in series with the operating coil and external capacitor. The purpose of the external resistor is to limit the power surge through the tank circuit of the operating coil and external capacitor. The normally-closed long-wipe contact at Position 3 opens with a delay after the operating coil has been fully energized so that the external capacitor can be fully charged before the long-wipe contact opens the circuit and the applied voltage is cut off. However, the charged external capacitor has sufficient energy to back up the operating coil, to ensure proper latch-holding of the armature. See Figs. 11, 12, and 13 for outlines of the external capacitor and resistor.

BURDENS

The operating coil burdens listed Table VII are measured with the relay in the picked up position, at rated voltage, and are for continuous rating. The common AC and DC burden table, VIII, applies to all HFA relays except HFA54M and HFA54N, whose burdens are listed in Table IX.

TABLE VII

DC COILS		AC COILS		
WATTS		FREQUENCY CYCLES	VOLT- AMPERES	WATTS
COLD	HOT			
7.3	6.0	25	10	4
-	-	50	23	9
-	-	60	32	12

TABLE VIII

DC COILS		AC COILS	
RATING	RESISTANCE	FREQUENCY	VOLT-AMPS
250	590	25	55
125	160	50	220
62.5	47.5	60	180
48	29	-	-
32	12	-	-
24	7.1	-	-
12	2.1	-	-
6	0.49	-	-

Burden ratings and the value of external resistors and capacitors for HFA54M and HFA54N are given in Table IX.

\*TABLE IX

	RESET COIL VOLTS	OPERATING COIL VOLTS	RESISTANCE OF RESET COIL OHMS**	RESISTANCE OF OPER. COIL OHMS**	EXTERNAL RESISTOR OHMS**	EXTERNAL CAPACITOR $\mu$ F**
1	125	125	185	2,000	100	5
2	48	48	26	366	50	15
3	250	250	740	8,000	200	5
* 4	48	250	26	8,000	200	5
* 5	48	230/60HZ	26	52.8	1650	5
* 6	230/60HZ	230/60HZ	185	52.8	1650	5
* 7	120/60HZ	250	26	8,000	200	5
* 8	115/60HZ	115/60HZ	26	13	200	5
* 9	115/60HZ	125	26	2,000	100	5

\*\* Resistance and capacitance values are nominal; variation is  $\pm 10\%$

#### RECEIVING, HANDLING AND STORAGE

These relays, when not included as a part of a control panel, are shipped in cartons designed to protect them against damage. Immediately upon receipt of a relay, examine it for any damage sustained in transit. If injury or damage resulting from rough handling is evident, file a damage claim at once with the transportation company and promptly notify the nearest General Electric Sales Office.

Reasonable care should be exercised in unpacking the relay in order that none of the parts are injured or the adjustments disturbed.

If the relays are not to be installed immediately, they should be stored in their original cartons in a place that is free from moisture, dust and metallic chips. Foreign matter collected on the outside of the case may find its way inside when the cover is removed and cause trouble in the operation of the relay.

#### INSTALLATION

Type HFA relays should be mounted on a vertical surface. The outline, panel drilling diagrams, and internal connections are shown in Figs. 4 to 13. Surface mounting on steel panels requires an insulating bushing for each terminal.

#### PERIODIC CHECKS AND ROUTINE MAINTENANCE

In view of the vital role of relays in the operation of power systems, it is important that a periodic test program be followed. It is recognized that the interval between periodic checks will vary depending upon environment, type of relay and the user's experience with periodic testing. Until the user has accumulated enough experience to select the test interval best suited to his individual requirements, it is suggested that the pickup voltages and condition of contacts be checked at an interval of from one to two years. See the section on SERVICING AND ADJUSTMENTS.

SERVICING AND ADJUSTMENTSCONTACT CLEANING

In cleaning fine silver contacts a flexible burnishing tool should be used. This consists of a flexible strip of metal with an etched, roughened surface, resembling, in effect, a superfine file. The polishing action is so delicate that no scratches are left, yet corroded material will be removed rapidly and thoroughly.

Fine silver contacts should not be cleaned with knives, files, or abrasive paper or cloth.

The burnishing tool described is included in the standard XRT11A relay tool kit obtainable from the factory.

CONTACT ADJUSTMENT

The contacts should not require readjustment since they are self-aligning.

Any contact circuit can be changed (except as noted in the **CHARACTERISTIC** section) from circuit-opening to circuit-closing, or vice versa, by removing the fixed contact, turning it over and returning it to its place.

If for any reason it becomes necessary to readjust the contacts, for instance if a contact is changed from circuit-opening to circuit-closing, the following checks and adjustments should be made:

1. Make sure that all contact and coil studs are tight.
2. Make sure that the armature is free of binding when operated by hand. The braided "pigtail" lead on all contacts must be adjusted to exert minimum force on the contacts.
3. Make mechanical contact adjustments as follows:
  - 3.1. Normally-Open Contacts, Wipe and Gap (Normally-open contacts must be adjusted before normally-closed contacts.)
    - a. The moving contact arms must be adjusted so that the normally-open contacts make approximately simultaneously ( $\pm 0.008$ ) when the relay is operated by hand. All normally-open contacts must have a wipe of 3/64 to 3/32 inches. The contact gap must be approximately 7/32 inch. This can be adjusted as follows:
      - i) Insert a 0.058 gage between the armature and pole face and close the armature.
      - ii) Bend the left-hand moving contact to just light the continuity lamp.
      - iii) Remove the 0.058 gage and bend the remaining moving contacts so that all moving contacts make at approximately the same time.

- iv) To check performance, turn the stop screw in until one contact continuity lamp is lit. Turn stop screw in an additional 1/2 turn and all continuity lamps should be lit.

Back off the stop screw to obtain at least 1/4 inch contact gap.

- v) Insert a 7/32-inch gage between any of the normally-open moving and stationary contacts and turn the stop screw clockwise until the continuity lamp lights. Lock the stop screw in this position with the locking nut.

### 3.2. Normally-Closed Contact Gap and Wipe

- a. The moving contact arms must be adjusted so that the normally-closed contacts make approximately simultaneously ( $\pm 0.008$ ) when the relay is operated by hand. The wipe and gap are automatically set by the formation of the stationary contacts and the strength of the control spring. Adjustments can be made as follows:
  - i) Turn the stop screw clockwise until the first normally-closed contact opens.
  - ii) Turn the stop screw an additional 1/2 turn clockwise. All normally-closed contacts should be open.
  - iii) Turn stop screw counterclockwise until there is approximately 1/8 gap between the stop screw and armature. Lock the stop screw in this position.

#### PICKUP

The main coil should be adjusted to pick up at 80% of rated voltage for AC relays, and 60% of rated voltage for DC relays. This adjustment may be obtained by unseating the knurled adjusting nut at the lower end of the armature and turning this nut in a clockwise direction to raise the pickup. The pickup is decreased by turning the nut in the counterclockwise direction.

The reset coil should pick up at 80% of rated AC voltage, and 50% to 75% of rated DC voltage. There is no adjustment available to alter this pickup. Since the reset coil is rated intermittently, care should be exercised when applying this voltage.

After all adjustments are completed, the mounted relay should be operated a few times to be certain that the mechanism operates freely and that the contact surfaces align properly. Check to see that the armature latches in when operated by hand, and opens readily when reset.

#### RENEWAL PARTS

When ordering renewal parts, address the nearest Sales Office of the General Electric Company, specify quantity required, name of the part wanted, and the complete nameplate data. The renewable parts publication is GEF-2757.

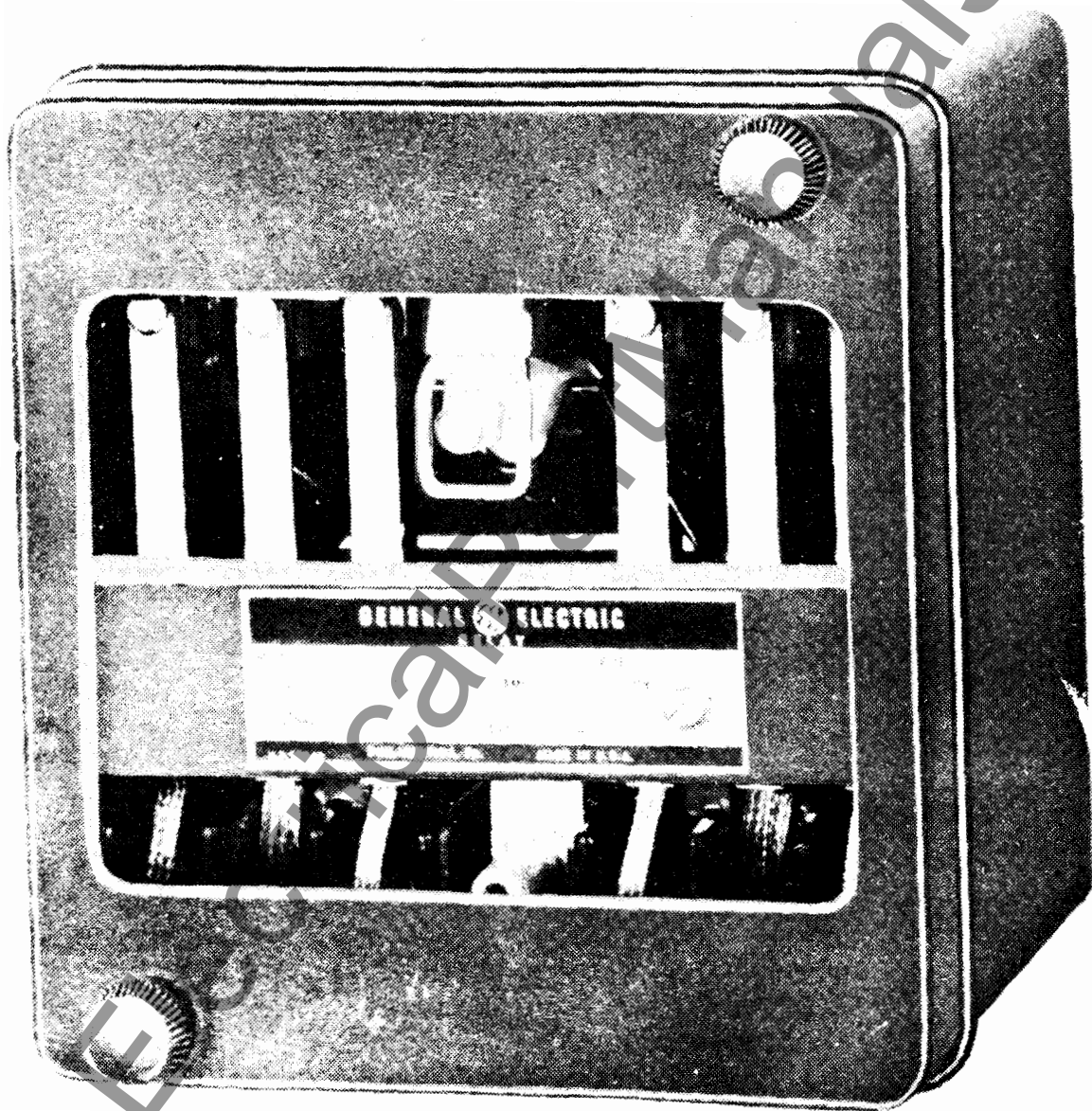

FIG.1 (8025534) HFA54 RELAY, BACK CONNECTED, SURFACE MOUNTED (FRONT VIEW)



FIG. 2 (8025781) HFA54 RELAY, FRONT CONNECTED, SURFACE MOUNTED (FRONT VIEW)



FIG. 3 (8025539) HFA54 RELAY, BACK CONNECTED, SEMI-FLUSH MOUNTED (FRONT VIEW)

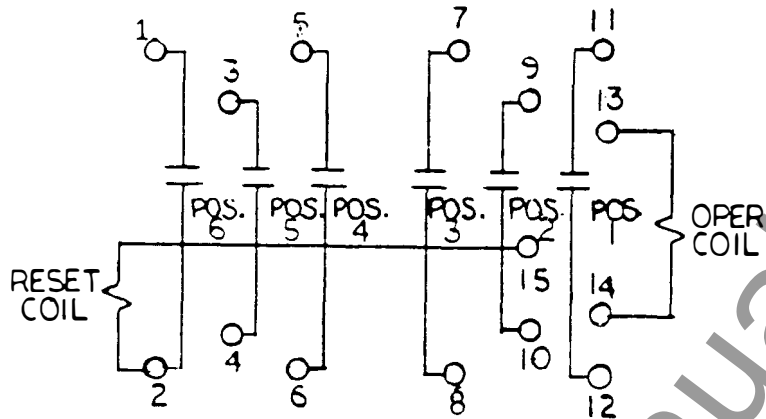

INTERNAL CONNECTIONS  
BACK VIEW

EACH CONTACT CONVERTIBLE ONLY  
ACCORDING TO CONTACT  
ARRANGEMENT CODE.

FIG. 4 (0104A8528-5) INTERNAL CONNECTIONS OF HFA54B, HFA54C, HFA54D,  
and HF54E RELAYS (BACK VIEW)

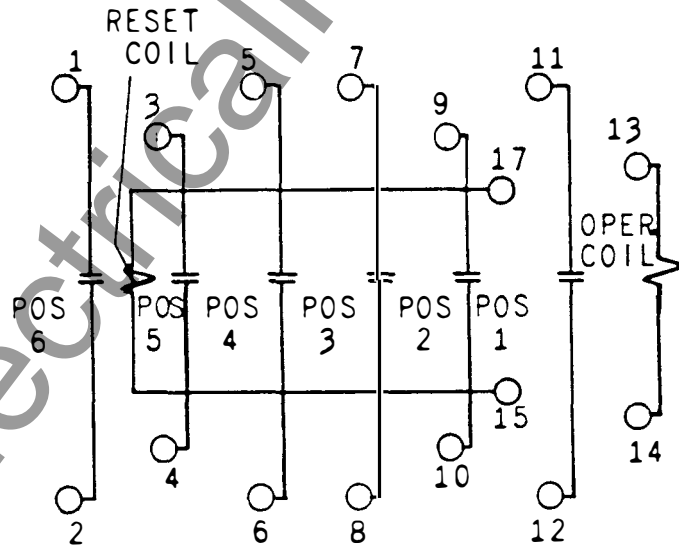

INTERNAL CONNECTIONS  
BACK VIEW

FIG. 5 (6375837-4) INTERNAL CONNECTIONS OF HFA54H, HFA54J, HFA54K,  
and HF54L RELAYS (BACK VIEW)

CODE NO.	1	2	3	4
POS. NO.	CONT. ARRANGE			
1	a	a	a	a
2	a	a	b	a
3	b1	b1	b1	b1
4	a	b1	b	b
5	a	a	a	b
6	a	a	a	a

a - N.O. CONTACT
a1 - N.O. CONTACT, LONG WIPE
b - N.C. CONTACT
b1 - N.C. CONTACT, LONG WIPE

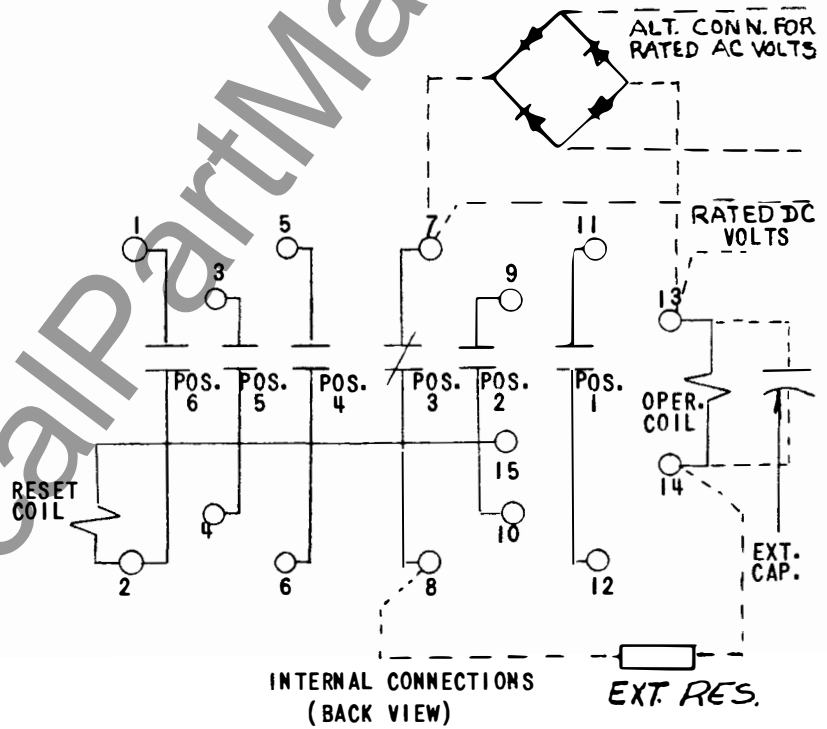

\*FIG. 6 (0207A7851-4) INTERNAL CONNECTIONS OF HFA54M AND HFA54N (BACK VIEW)



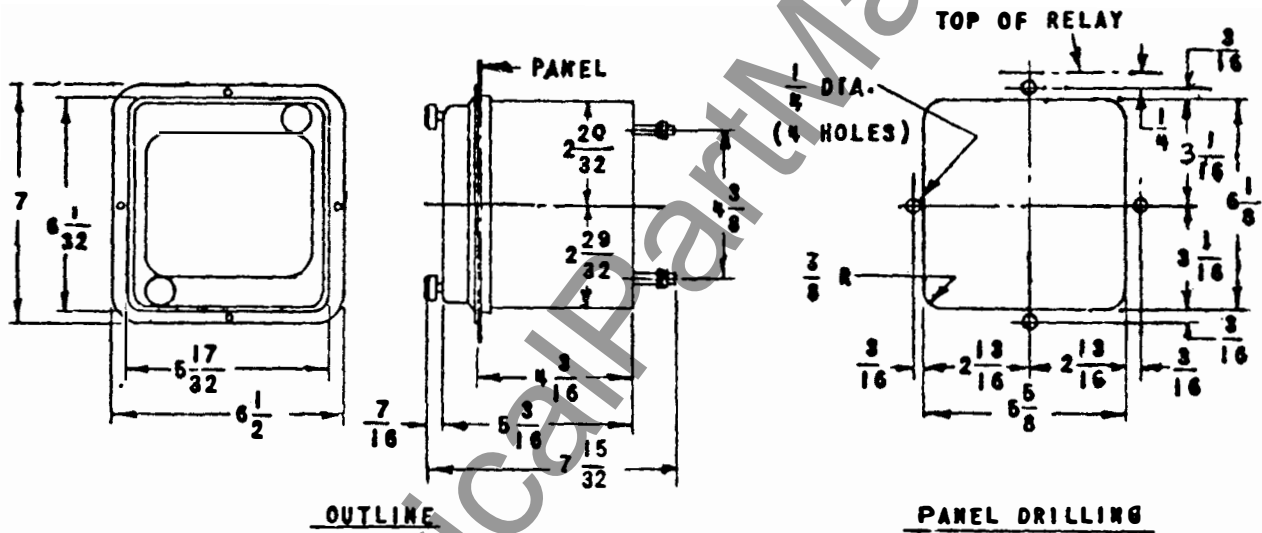

\*FIG. 8 (0418A0799-8) OUTLINE AND PANEL DRILLING DIAGRAM FOR HFA54 RELAYS FOR SEMI-FLUSH MOUNTING (TYPICAL MODEL NUMBER IS HFA54B(-)F)





GEI-68720

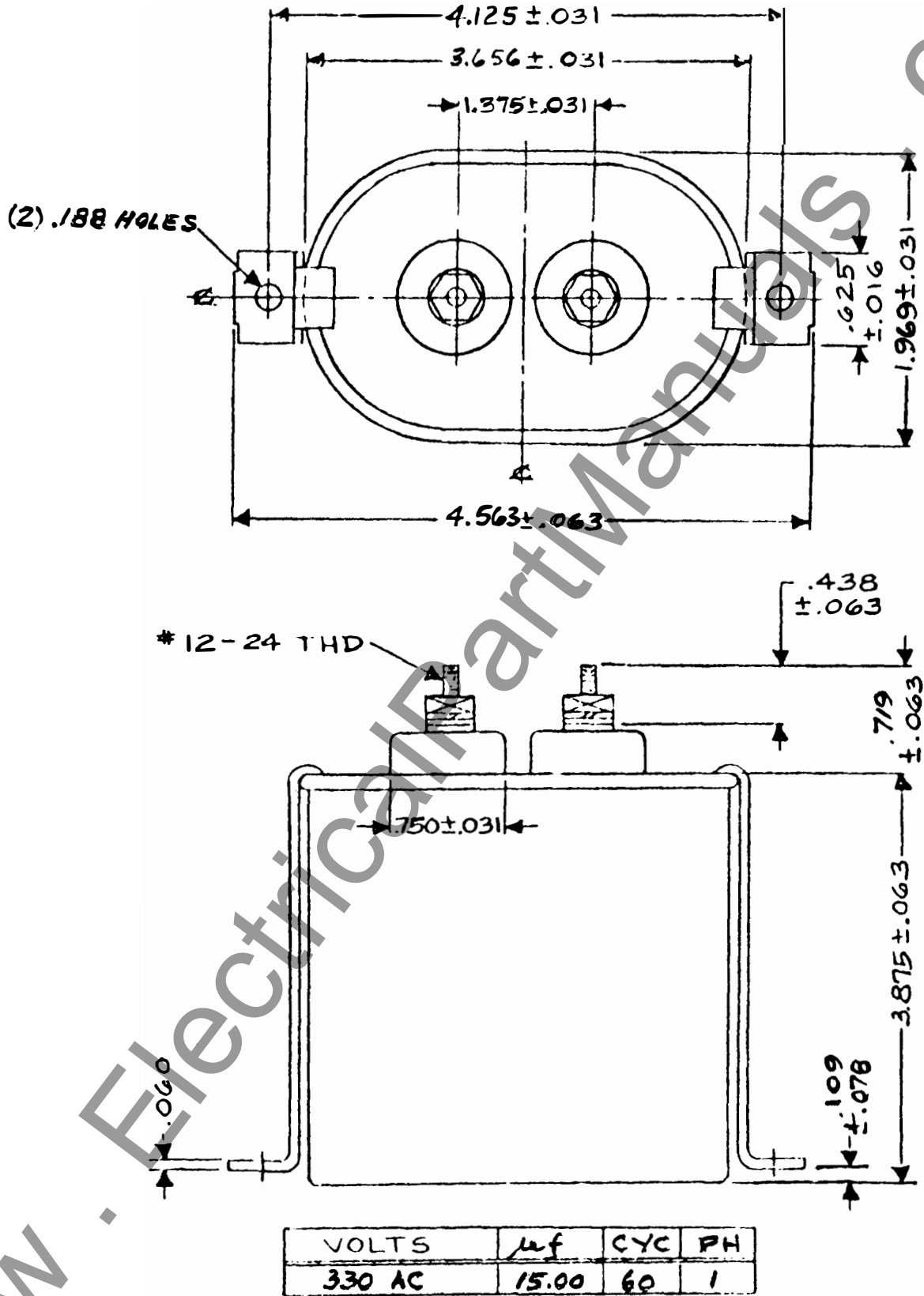

FIG. 12 (0028F0915-0 SH. 2) OUTLINE OF EXTERNAL CAPACITOR 15 μF

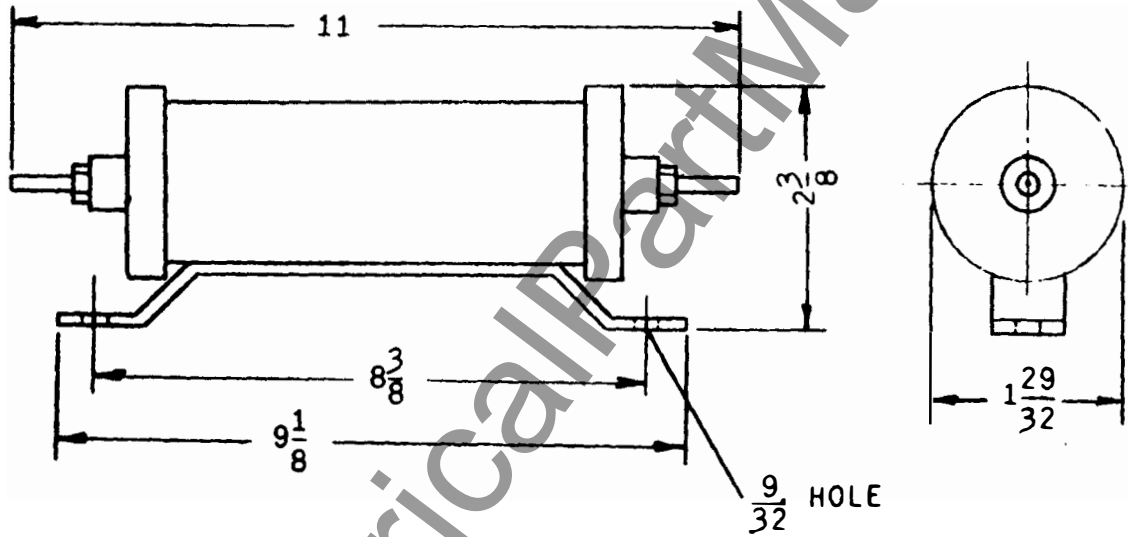

FIG. 13 (0389A0752-2) OUTLINE OF EXTERNAL RESISTOR USED WITH HFA54M and HFA54N RELAYS

[www.ElectricalPartManuals.com](http://www.ElectricalPartManuals.com)

[www.ElectricalPartManuals.com](http://www.ElectricalPartManuals.com)

[www.ElectricalPartManuals.com](http://www.ElectricalPartManuals.com)

www.ElectricalPartManuals.com

***Meter and Control  
Business Department***

(8/91) (500)

---

General Electric Company  
Protection and Control  
205 Great Valley Parkway  
Malvern, Pennsylvania 19355-0715