



INSTRUCTIONS

GEI-93825C

**SYNCHRONISM CHECK RELAY
TYPE IJS52E**

GENERAL  ELECTRIC

SYNCHRONISM CHECK RELAY

TYPE IJS52E

INTRODUCTION

The Type IJS52E relays are of the induction-disk construction and are intended for use as synchronism-check relays.

The synchronism-check unit has two shaded-pole U-magnet driving-elements acting on opposite sides of a single rotating disk. (See Fig. 2). One of these, the operating element, drives the disk in the contact-closing direction, and the other, the restraining element drives the disk in the opposite direction. The disk shaft is restrained by a spiral spring, the purpose being to hold the contacts open when the relay is de-energized. The motion of the disk is retarded by permanent magnets (drag magnets) acting on the disk to give a time delay.

The Type IJS52E relay has two telephone-type undervoltage units. These are designated as "B" and "L" on Fig. 7.

The Type IJS52E relay does not have a seal-in unit since one is not required in its normal application.

APPLICATION

The IJS52E is designed for situations requiring a combination of synchronism-check operation, with a time-delay dead-line-live-bus and/or dead-bus-live-line check.

It performs either or both of the voltage checking functions (as selected by external switch contacts) by means of internally mounted instantaneous voltage relays which connect both coils of the IJS unit to the bus or line when the voltage on the opposite side of the controlled breaker is 15% or less of rated value. The pickup time of the IJS unit at 0° is thus the closing delay for the dead-line-live-bus and/or the live-line-dead-bus checking function.

The IJS52E performs the synchronism-check function in the usual manner whenever the voltage on each side of the controlled breaker is at or above 45% of rated value, since that insures that both of the instantaneous voltage relays will be picked up, and in that position they connect the coil circuits of the IJS unit to the bus and line so that the unit responds to phase relations in the usual way.

The only contact available for external use is that of the IJS unit.

RATING

The operating and restraining coils of the synchronism-check unit are continuously rated. The contact of this unit will make and carry momentarily 30 amperes but it has no interrupting rating.

The telephone-type voltage relay contacts will make and carry 30 amperes momentarily for normal duty but the circuit must be opened by a breaker auxiliary unit or other suitable means.

The telephone-type relays have operating coils rated at 115 volts.

CHARACTERISTICS

Operating Principles

The operating coils, mounted on the left-hand side, produce a torque tending to close the synchronism-check contact. This torque is proportional to the vector sum of the voltages whose phase positions are being compared. The torque produced by the restraint coils is proportional to the vector difference of the voltages. The operating torque is maximum when they are in phase opposition; the reverse is true of the restraining torque.

The closing angle of the relay is defined as the maximum phase displacement of the two voltages at which the relay will close its synchronism-check contact when the voltages are at rated value. The 20 degree closing angle is considered standard; however, other settings may be made as indicated by the voltage-phase angle characteristics shown in Fig. 1.

The time-delay characteristics of the Type IJS relay are obtained primarily by the time-dial setting. The time dial controls the distance the contacts must travel before closure and hence, controls the time delay. At No. 10 time-dial setting the travel is maximum, whereas, at No. 0 the contacts are just closed. A certain amount of adjustment may be made by changing the position of the drag magnet on its shelf. Moving it toward the disk shaft decreases the time delay while moving it away from the disk shaft increases the time delay.

These instructions do not purport to cover all details or variations in equipment nor to provide for every possible contingency to be met in connection with installation, operation or maintenance. Should further information be desired or should particular problems arise which are not covered sufficiently for the purchaser's purposes, the matter should be referred to the General Electric Company.

To the extent required the products described herein meet applicable ANSI, IEEE and NEMA standards; but no such assurance is given with respect to local codes and ordinances because they vary greatly.

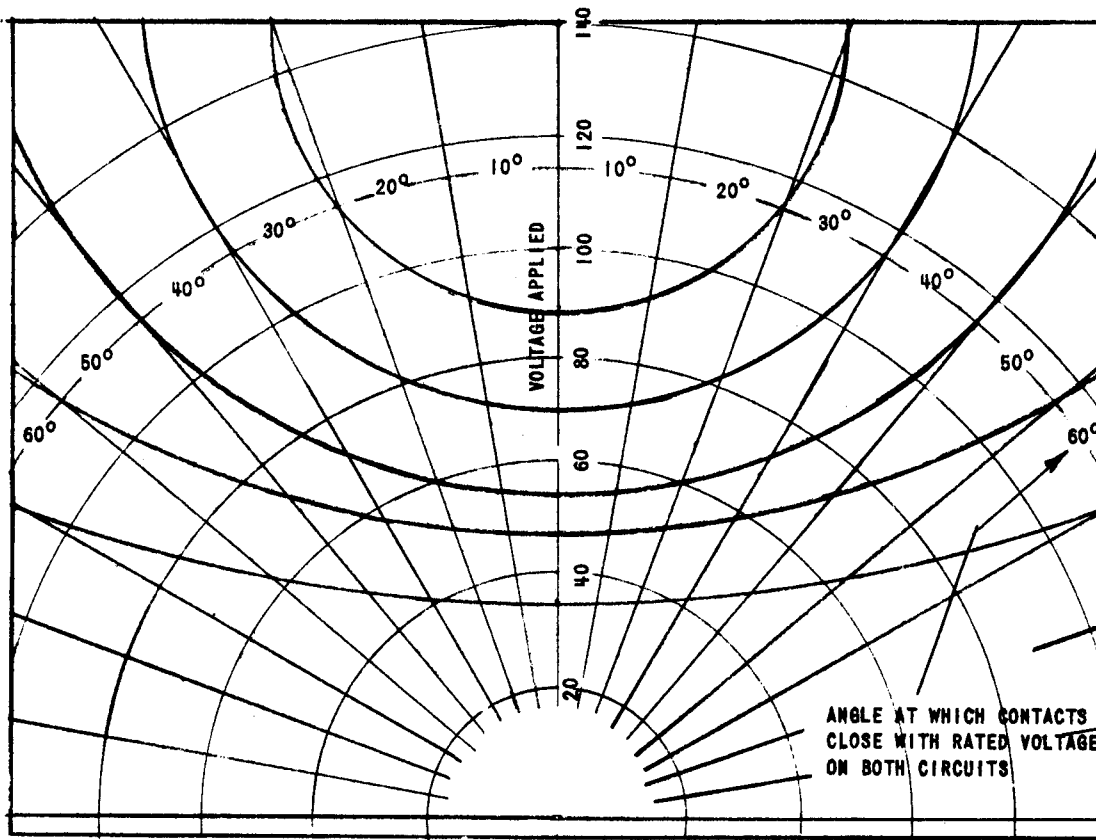

Fig. 1 (0165A7535-0) Typical Phase-Angle Characteristic of 115 Volt 50/60 Cycle Relay for Various Closing Adjustments with Rated Voltage Maintained on One Circuit. Standard Closing Angle Adjustment 20°

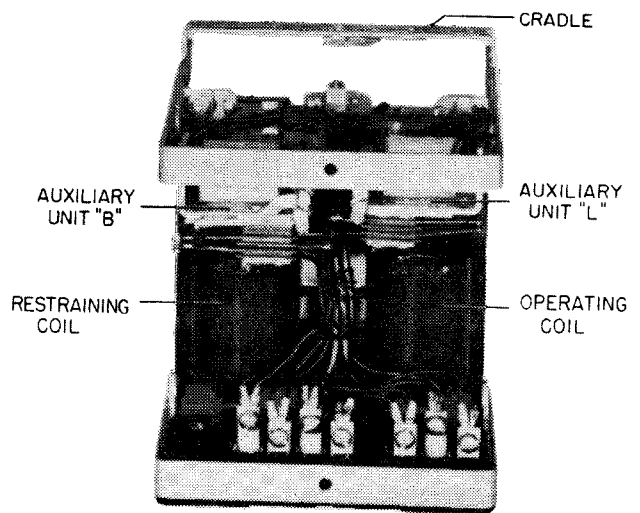
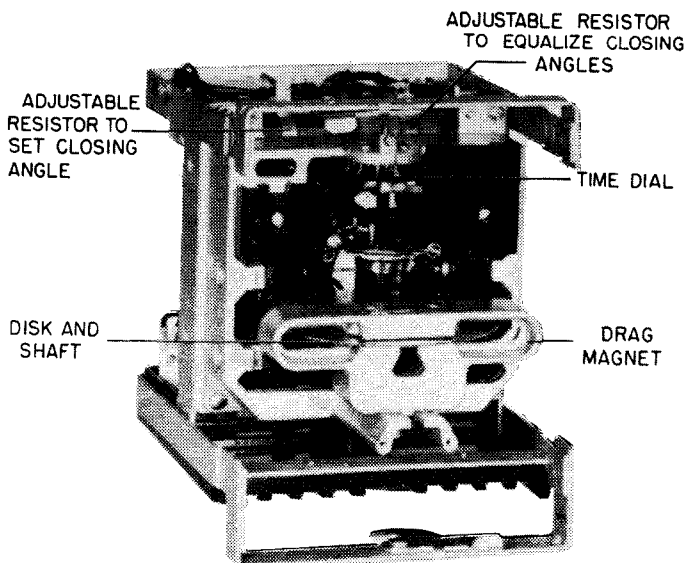

Fig. 2 (8030534) Type IJS52E Relay Unit in Cradle (Front View)

Fig. 3 (8030535) Type IJS52E Unit in Cradle

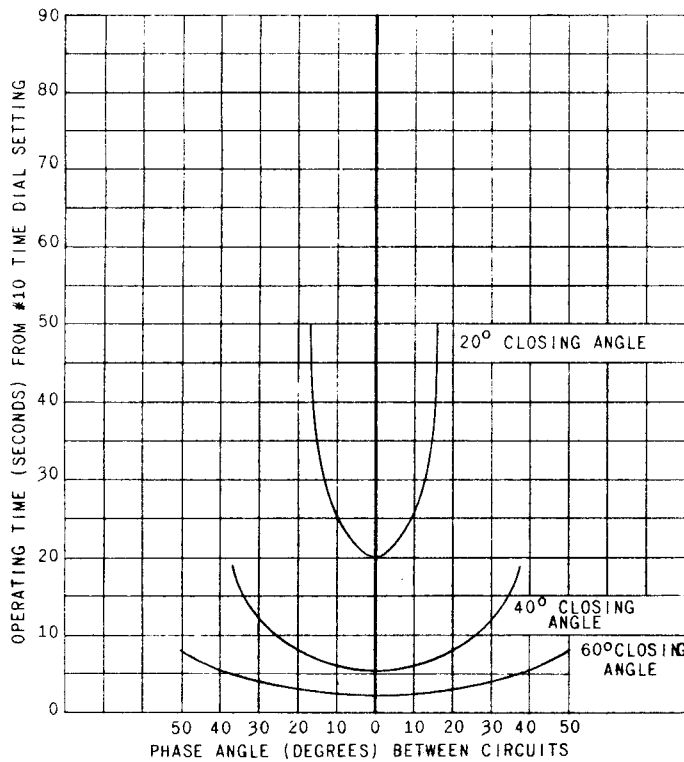

Fig. 4 (K-6400151-3) Typical Time-Phase Angle Curve with Rated Voltage Relay Type IJS52E1

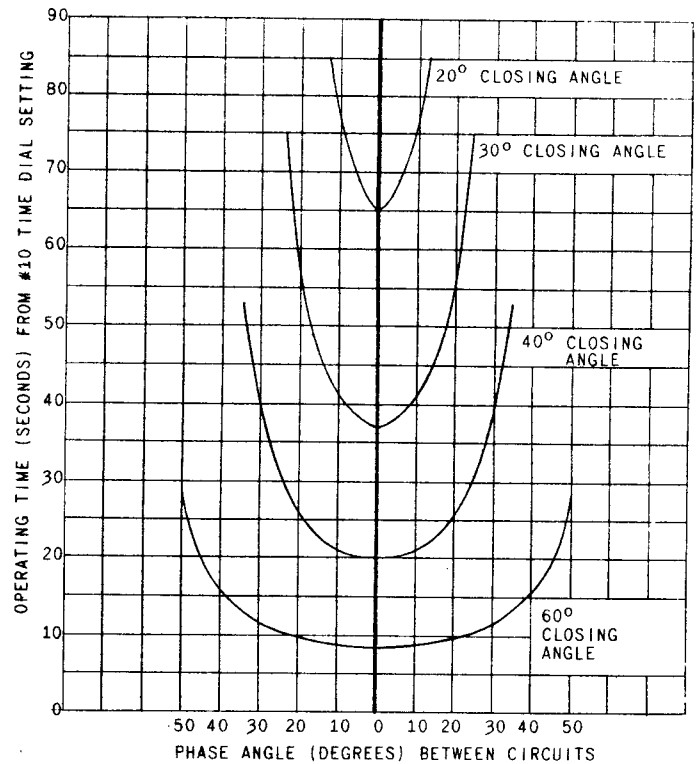

Fig. 5 (376A964-1) Typical Time-Phase Angle Characteristic of 50/60 Cycle Relay IJS52E3 with Rated Voltage on Both Circuits

Typical time vs phase-angle curves are shown in Figs. 4 and 5 for 60 cycle relays. The Model 12IJS52E1 relay has a standard closing angle setting of 20 degrees and has its drag magnet adjusted to provide 20 seconds time delay from No. 10 time-dial setting for voltages in phase. The closing angle on this relay can be adjusted to angles greater than 20 degrees but with a corresponding decrease in time delay as shown in Fig. 4. The approximate reset time with both coils de-energized is about 40 seconds. The approximate reset time with one coil energized at rated voltage varies from 3 seconds on the 20° setting to 6 seconds on the 60° setting with #10 T.D.S.

The Model 12IJS52E3 relay, which is designed for use where a closing angle greater than 20 degrees is required, provides 20 seconds delay at the 40 degree closing-angle setting, as shown in Fig. 5. It may be adjusted to other closing angles between 20 and 60 degrees with corresponding changes in time delay as shown in Fig. 5. The approximate reset time with both coils de-energized is about 130 seconds at #10 T.D.S. The approximate reset time with one coil energized at rated voltage varies from 13 seconds on the 20 setting to 20 seconds on the 60° setting at #10 T.D.S.

Fig. 6 gives the operating time in seconds for various time-dial settings with zero phase displacement and with rated voltage at 60 cycles on both circuits. Curves for 50 cycles are similar. The telephone-type undervoltage units are calibrated

to pick up between 35 and 52 volts and to drop out between 17 and 35 volts.

BURDENS

The burdens for the synchronism-check unit are given in Table "A". The burden varies with the phase displacement of the two voltages with a minimum at zero degrees to a maximum at 180°.

TABLE A

Volts	Cycles	Circuit	Phase Diff.	Watts	Volt Amps	P.F.
115	60	4-5	0°	3.00	11.6	0.258
		4-5	180°	3.76	12.0	0.313
		7-8	0°	3.30	10.9	0.300
		7-8	180°	4.07	11.3	0.360
115	50	4-5	0°	4.35	14.2	0.306
		4-5	180°	5.25	14.6	0.359
		7-8	0°	4.75	13.3	0.357
		7-8	180°	5.60	13.9	0.403

The burdens of telephone-units is 13 volt-amperes and 8 watts for each unit at 115 volts, 60 cycles.

CONSTRUCTION

The relay components are mounted in a cradle assembly which is latched into a drawout case when the relay is in operation but they can be easily

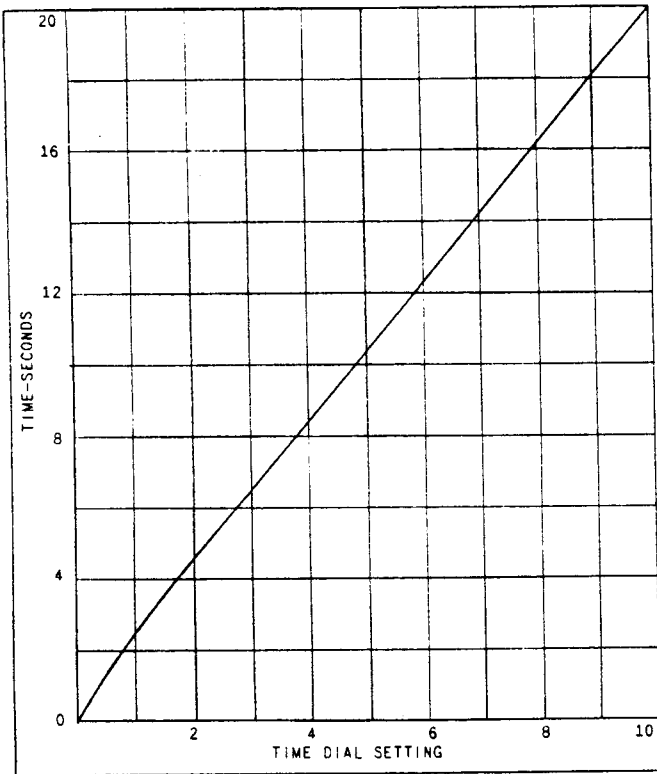

Fig. 6 (K-6400150-2) Operating Time of Type IJS Relay with 20° Closing Angle at 0°, 115 Volts 50/60 Cycles on Both Circuits

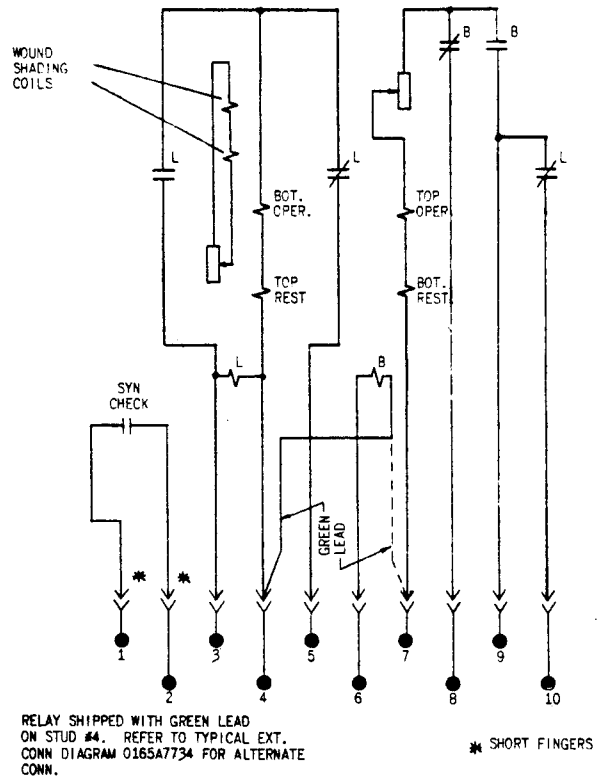

Fig. 7 (0165A7608-1) Internal Connection Diagram for Relay Type IJS52E

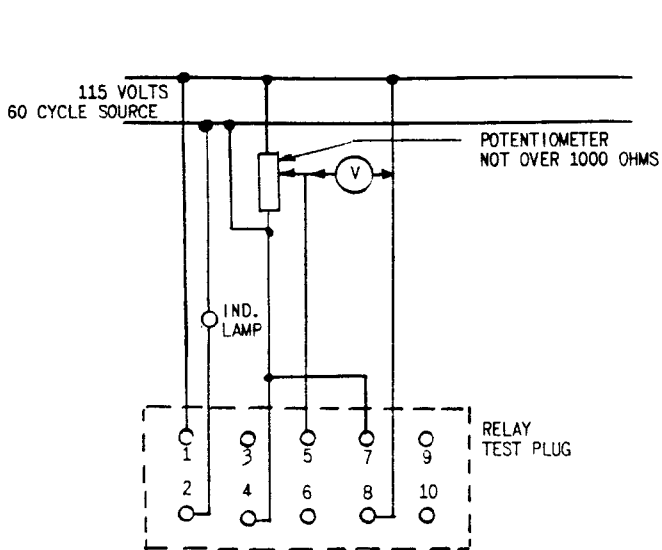

Fig. 8A (0165A7736-0) Test Connections for Single Phase Closing Angle Check. Relay Type IJS52E

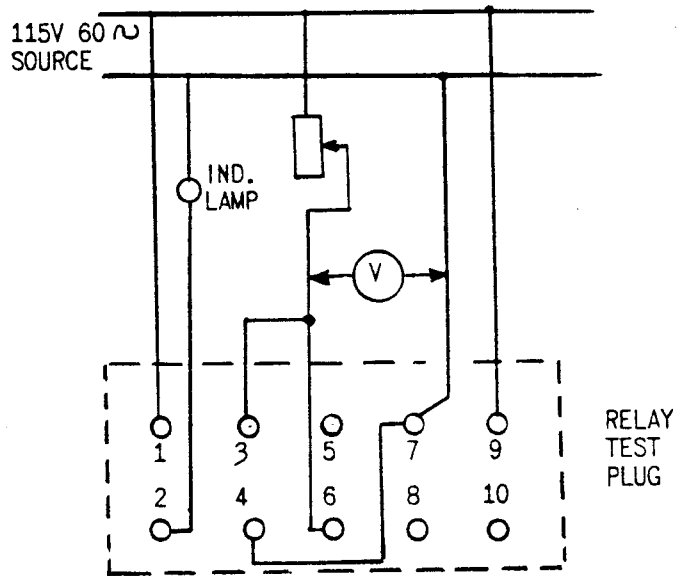

Fig. 8B (0165A7737-0) Test Connections for Relay Type IJS52E

removed when desired. To do this, the relay is first disconnected by removing the connection plug which completes the electrical connections between the case blocks and the cradle block. To test the relay in its case this connection block can be replaced by a test plug. The cover, which is attached to the front of the relay case, contains an interlock arm which prevents the cover from being replaced until the connection plugs have been inserted.

The relay case is suitable for either semi-flush or surface mounting on all panels up to 2 inches thick and appropriate hardware is available. However, panel thickness must be indicated on the relay order to insure that proper hardware will be included. For outline and drilling dimensions, see Fig. 13.

Every circuit in the drawout case has an auxiliary brush, as shown in Fig. 12, to provide adequate overlap when the connecting plug is withdrawn or inserted.

Internal connections for the LJS52E are shown in Fig. 7.

RECEIVING, HANDLING AND STORAGE

These relays, when not included as part of a control panel, will be shipped in cartons designed to protect them against damage. Immediately upon receipt of a relay, examine it for any damage sustained in transit. If injury or damage resulting from rough handling is evident, file a damage claim at once with the transportation company and promptly notify the nearest General Electric Apparatus Sales Office.

Reasonable care should be exercised in unpacking the relay. If the relays are not to be installed immediately, they should be stored in their original cartons in a place that is free from moisture, dust and metallic chips. Foreign matter collected on the outside of the case may find its way inside when the cover is removed and cause trouble in the operation of the relay.

ACCEPTANCE TESTS

Immediately upon receipt of the relay, an inspection and acceptance test should be made to insure that no damage has been sustained in shipment and that the relay calibrations have not been disturbed. If the examination or tests indicate that readjustment is necessary, refer to Section on **SERVICING**.

Visual Inspection

Check the nameplate stamping to insure that the Model Number and rating of the relay agree with the requisition.

Remove the relay from its case and check that there are no broken or cracked molded parts or other signs of physical damage and that all screws are tight.

Check that the short fingers are in the correct location as indicated in Fig. 7 and that the auxiliary brushes are properly adjusted (see Fig. 12).

Mechanical Inspection

1. Check that the rotating element moves without noticeable friction.
2. Remove the time dial locking screws and check that the moving contact just touches the stationary contact when the time dial is set at zero. The contact wipe should be approximately 1/32".
3. Check that the control spring is not deformed and the spring convolutions at No. 5 T.D.S. are reasonably concentric.
4. Check that the armatures of the telephone relays move freely. Also with telephone relays in the de-energized position all circuit closing contacts should have a gap of 0.015" and all circuit opening contacts have a wipe of 0.005". Gap may be checked by inserting a feeler gage and wipe can be checked by observing the amount of deflection on the stationary contact before parting the contacts. The armature should then be operated by hand and the gap and wipe again checked as described above.

Electrical Tests

Connect the relay as shown in Fig. 10 and check the following:

1. Check that the relay picks up with at least 115 volts, 60 cycle single-phase source connected to both operating coils with approximately the time delay shown in Fig. 6.
2. Check that the relay picks up at a 20° closing angle (or other closing angle if used) within ± 3 degrees when connected to a 115 volt, 60 cycle source with rated voltages on both coils. Check zero displacement pick up which should agree with the value in Fig. 1 within ± 10 percent.
3. With both coils connected to a 115 volt source with zero displacement, check that pick up time agrees with values given in Figs. 4 or 5 plus or minus 10 percent.
4. With a 115 volt, 60 cycle source and connection shown in Fig. 8B, check that the telephone-type units pickup between 35 and 52 volts and that these units drop out between 17 and 35 volts.

INSTALLATION PROCEDURE

If after acceptance tests the relay is held in storage before shipment to the job site, it is recommended that visual and mechanical inspection described under the section on **ACCEPTANCE TESTS** be repeated before installation.

Electrical Tests

Before the following electrical tests are made the relay should be in its case, preferably mounted in its permanent location.

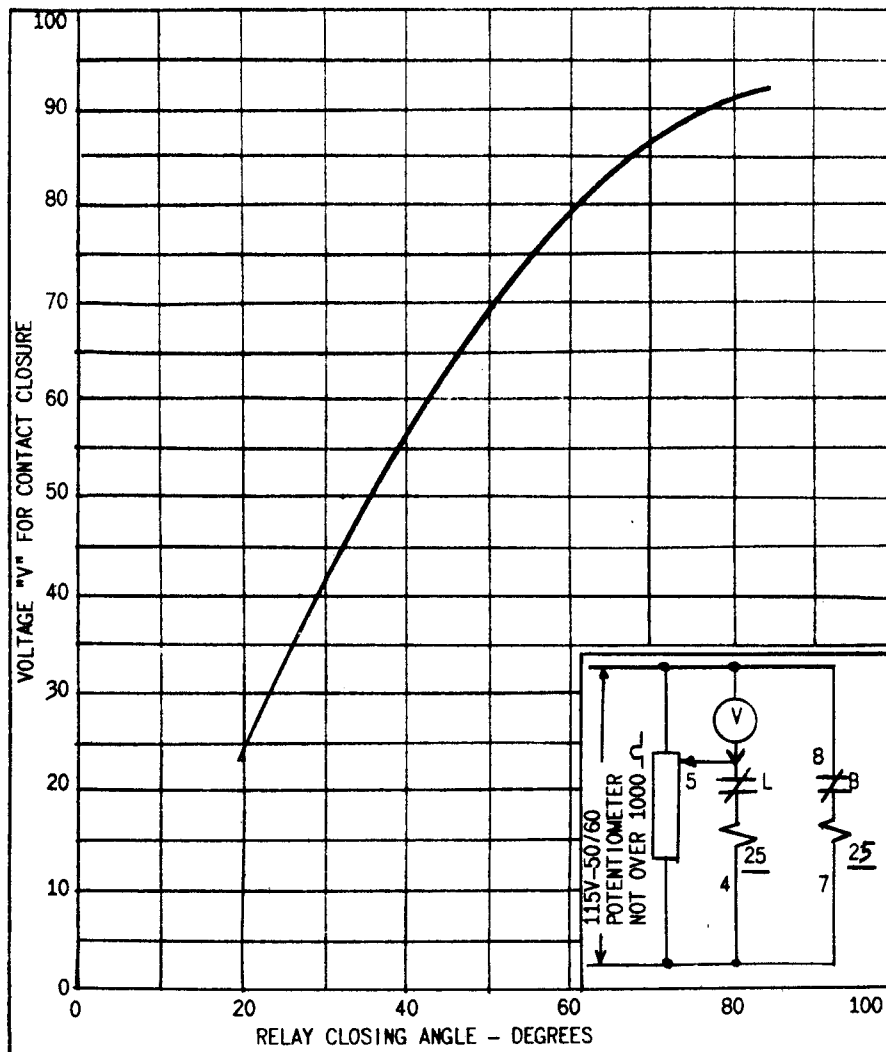

Fig. 11 (0165A7739-0) Connections and Curve to Make Closing Angle Adjustment Without Phase Shifter on 115 Volt 50/60 Cycle Relay. Relay Type IJS52E

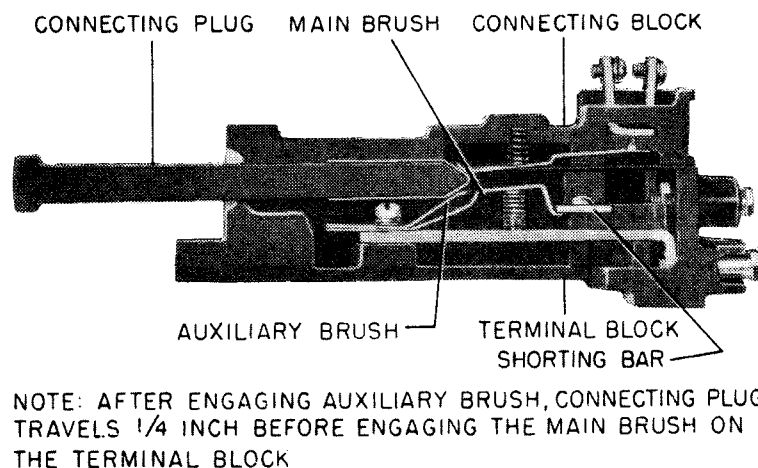

Fig. 12 (8025039) Cross Section of Drawout Case Showing Position of Auxiliary Brush and Shorting Bar

GEI-93825 Synchronism Check Relay Type IJS

The reclosing closing angle should be set as required for its permanent location which would normally be 20 degrees. Connect the relay as shown in Fig. 10 and check that the relay picks up at the proper phase angle plus or minus 3 degrees.

If a phase angle meter or a phase shifter is not available, it is possible to adjust the relay to approximately the closing angle desired by means of the connections and curve shown in Fig. 11. In this test, rated voltage is held on one circuit (studs 7-8) and a reduced voltage is applied to the other circuit (studs 4-5). The voltage connected to studs 4-5 is adjusted until the synchronizing check unit just closes its contact. The difference between the two voltages should agree approximately with the voltage given on the curve shown in Fig. 11 for the phase angle used (i.e. 24 volts for 20 degrees closing).

When using either connections shown in Fig. 10 or Fig. 11, check the operating time at 0 displacement with 115 volts on each coil using the time dial setting of the permanent location. (See Fig. 6 for nominal time delay values).

Pick up and drop out of the telephone-type undervoltage relays should be checked as described in section on ACCEPTANCE TESTS.

PERIODIC CHECKS AND ROUTINE MAINTENANCE

In view of the vital role of protective relays in the operation of a power system it is important that a periodic test program be followed. It is recognized that the interval between periodic checks will vary depending upon environment, type of relay and the user's experience with periodic testing. Until the user has accumulated enough experience to select the test interval best suited to his individual requirements it is suggested that the following points be checked once a year. *

Contact Cleaning

For cleaning relay contacts, a flexible burnishing tool should be used. This consists of a flexible strip of metal with an etched-roughened surface, resembling in effect a superfine file. The polishing action is so delicate that no scratches are left, yet it will clean off any corrosion thoroughly and rapidly. Its flexibility insures the cleaning of the actual points of contact. Do not use knives, files, abrasive paper or cloth of any kind to clean relay contacts.

Mechanical

The mechanical checks described under the section on ACCEPTANCE TESTS should be repeated.

Electrical

Using connections in Fig. 8A.

1. Check that the maximum closing angle for pick-up of the synchronizing check unit agrees approximately with the value shown on the

curve in Fig. 11.

2. Check the closing time with the potentiometer set to provide 115 volts on both circuits. The time should agree with values given in Fig. 6 plus or minus 10 percent.
3. Using connections in Fig. 8B check the pick up and drop out of the telephone-type undervoltage units (27V and 27L).

SERVICING

If recalibration of the relay is necessary, the following should be considered when making adjustments.

Mechanical Adjustments

1. The moving contact should just touch the secondary contact when the time dial is set at the zero position. If readjustment is necessary, loosen the two clamping screws which fasten the stop arm to the shaft and change the position of a desired closing angle. The right-hand adjustable resistor at the top of the frame permits equalizing the closing angle. That is, the closing angle will be the same whether one voltage is leading or lagging the other voltage.

The left-hand adjusting resistor is for obtaining the correct closing-angle setting. Simultaneous adjustments of the two resistors are necessary.

Using connections shown in Fig. 10 set V_1 at 115 volts. If a 20 degree closing angle is desired, set V_2 at 115 volts, leading V_1 by 20 degrees. Adjust the left-hand resistor until the contacts just close. Now with 115 volts on both circuits, determine the angle at which the contact closes with V_2 lagging V_1 . If the two angles are unequal, equalize them at 20 degrees by adjusting the right-hand resistor. Then check the closing angle with V_2 leading V_1 , and readjust, if necessary. Continue this procedure until the relay contacts just close for V_1 leading or lagging V_2 by 20 degrees. Use the same procedure for other closing-angle settings.

The pick up and drop out of the telephone-type relay may be changed by adjusting the gap between the armature and the pole face by bending the contact operating arm stop. After this adjustment is made the contact wipe and gap must be rechecked.

If it is necessary to adjust the time characteristics, impose the chosen conditions on the stop arm relative to the moving contact until the contacts just touch with the time dial set at zero. A fine adjustment can be obtained by moving the stationary contact brush in or out by means of its adjusting screw. However, in the final adjustment, the contact brush must be positioned so that there is 1/64" to 1/32" wipe with the contact fully closed. Be sure that the screws are securely tightened after adjustment is made.

2. The stop arm leaf spring should deflect at

least 1/64" when synchronism-check unit is de-energized.

3. The disc and shaft assembly should have a vertical end play of 1/16" to 1/32" and both bearing screws should be tight. The disc should be approximately centered between the poles of the U-magnet and drag magnet.
4. Telephone-type relay contact gaps may be adjusted by bending the stationary contact brush to obtain 0.015 inch gap. When the adjustment is made, the wipe must be rechecked to insure a minimum of 0.005 inch wipe.

Electrical Adjustments

Closing Angle Adjustment

Connect the relay as shown in Fig. 10. To make an accurate adjustment of the closing angle, a phase shifter and phase angle meter are required along with a means for voltage control.

Two adjustments are necessary for obtaining a desired closing angle. The right-hand adjustable resistor at the top of the frame permits equalizing the closing angle. That is, the closing angle will be the same whether one voltage is leading or lagging the other voltage.

The left-hand adjusting resistor is for obtaining the correct closing-angle setting. Simultaneous adjustments of the two resistors are necessary.

Using connections shown in Fig. 10 set V₁ at 115 volts. If a 20 degree closing angle is desired, set V₂ at 115 volts, leading V₁ by 20 degrees.

Adjust the left-hand resistor until the contacts just close. Now with 115 volts on both circuits, determine the angle at which the contact closes with V₂ lagging V₁. If the two angles are unequal, equalize them at 20 degrees by adjusting the right-hand resistor. Then check the closing angle with V₂ leading V₁, and readjust, if necessary. Continue this procedure until the relay contacts just close for V₁ leading or lagging V₂ by 20 degrees. Use the same procedure for other closing-angle settings.

The pickup and dropout of the telephone-type relay may be changed by adjusting the gap between the armature and the pole face by bending the contact operating arm stop. After this adjustment is made the contact wipe and gap must be rechecked.

If it is necessary to adjust the time characteristics, impose the chosen conditions on the relay, using connections shown in Fig. 10 and adjust the time dial and, if necessary, the drag magnet until the correct operating time is obtained.

RENEWAL PARTS

It is recommended that sufficient quantities of renewal parts be carried in stock to enable the prompt replacement of any that are worn, broken, or damaged.

When ordering renewal parts, address the nearest Sales Office of the General Electric Company, specify quantity required, name of the part wanted and give complete nameplate data. If possible, give the General Electric requisition number on which the relay was furnished.

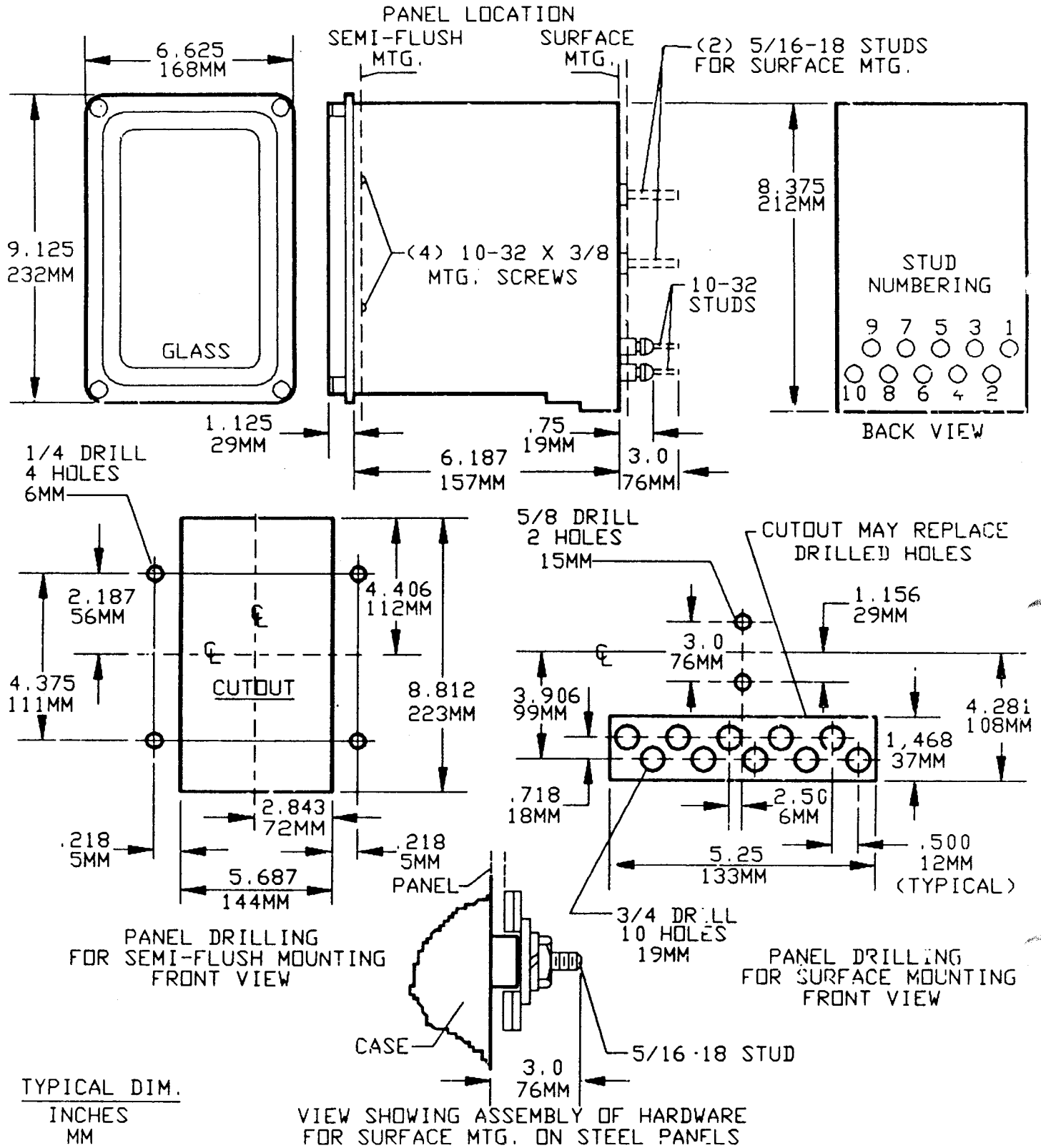

* Fig. 13 (K-6209271[8]) Outline and Panel Drilling Dimensions for Type IJS Relay

* Indicates Revision



INSTRUCTIONS

GEI-93825D

**SYNCHRONISM CHECK RELAY
TYPE IJS52E**

GENERAL  ELECTRIC

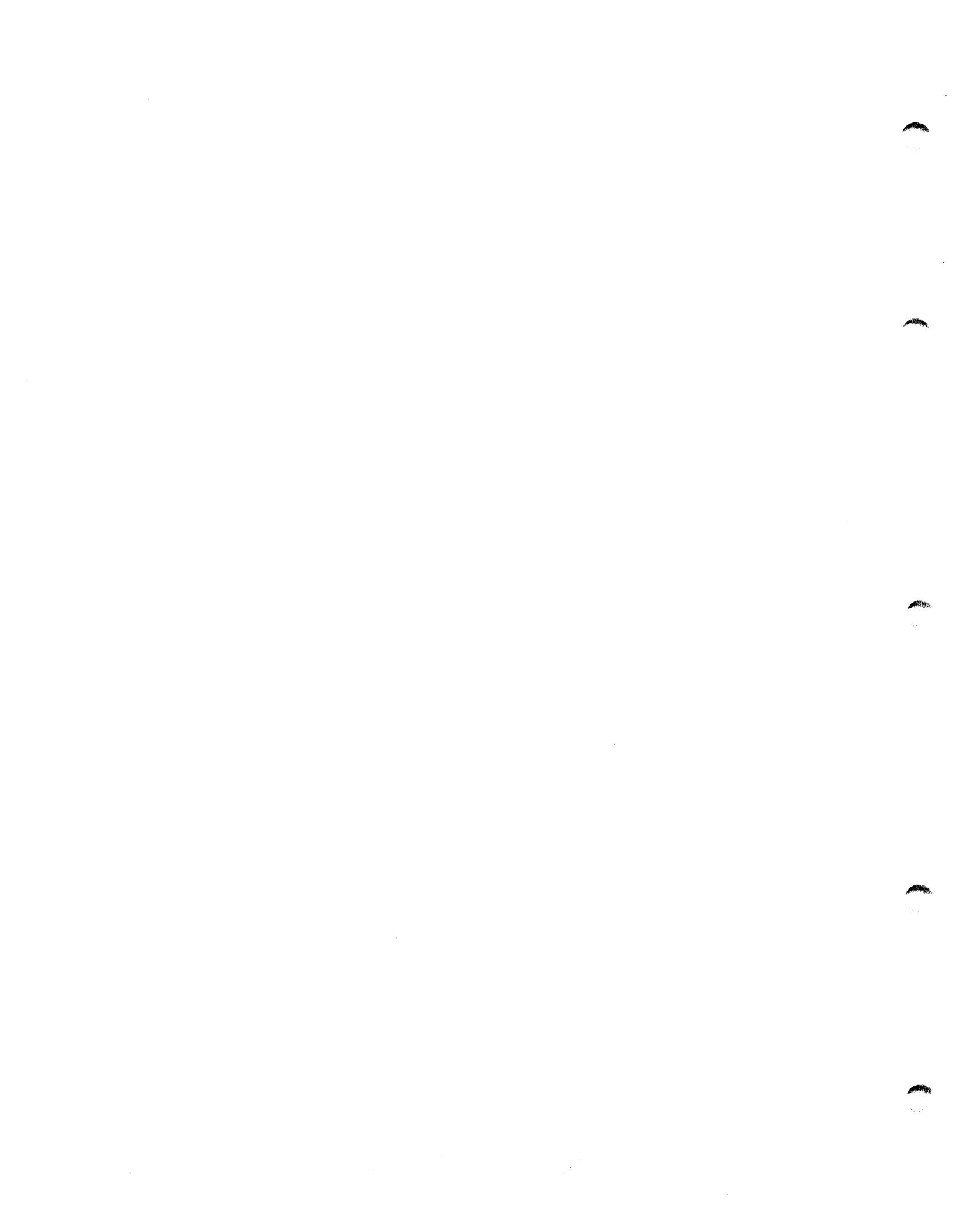

SYNCHRONISM CHECK RELAY

TYPE IJS52E

INTRODUCTION

The Type IJS52E relays are of the induction-disk construction and are intended for use as synchronism-check relays.

The synchronism-check unit has two shaded-pole U-magnet driving-elements acting on opposite sides of a single rotating disk. (See Fig. 2). One of these, the operating element, drives the disk in the contact-closing direction, and the other, the restraining element drives the disk in the opposite direction. The disk shaft is restrained by a spiral spring, the purpose being to hold the contacts open when the relay is de-energized. The motion of the disk is retarded by permanent magnets (drag magnets) acting on the disk to give a time delay.

The Type IJS52E relay has two telephone-type undervoltage units. These are designated as "B" and "L" on Fig. 7.

The Type IJS52E relay does not have a seal-in unit since one is not required in its normal application.

APPLICATION

The IJS52E is designed for situations requiring a combination of synchronism-check operation, with a time-delay dead-line-live-bus and/or dead-bus-live-line check.

It performs either or both of the voltage checking functions (as selected by external switch contacts) by means of internally mounted instantaneous voltage relays which connect both coils of the IJS unit to the bus or line when the voltage on the opposite side of the controlled breaker is 15% or less of rated value. The pickup time of the IJS unit at 0° is thus the closing delay for the dead-line-live-bus and/or the live-line-dead-bus checking function.

The IJS52E performs the synchronism-check function in the usual manner whenever the voltage on each side of the controlled breaker is at or above 45% of rated value, since that insures that both of the instantaneous voltage relays will be picked up, and in that position they connect the coil circuits of the IJS unit to the bus and line so that the unit responds to phase relations in the usual way.

The only contact available for external use is that of the IJS unit.

RATING

The operating and restraining coils of the synchronism-check unit are continuously rated. The contact of this unit will make and carry momentarily 30 amperes but it has no interrupting rating.

The telephone-type voltage relay contacts will make and carry 30 amperes momentarily for normal duty but the circuit must be opened by a breaker auxiliary unit or other suitable means.

The telephone-type relays have operating coils rated at 115 volts.

CHARACTERISTICS

Operating Principles

The operating coils, mounted on the left-hand side, produce a torque tending to close the synchronism-check contact. This torque is proportional to the vector sum of the voltages whose phase positions are being compared. The torque produced by the restraint coils is proportional to the vector difference of the voltages. The operating torque is maximum when they are in phase opposition; the reverse is true of the restraining torque.

The closing angle of the relay is defined as the maximum phase displacement of the two voltages at which the relay will close its synchronism-check contact when the voltages are at rated value. The 20 degree closing angle is considered standard; however, other settings may be made as indicated by the voltage-phase angle characteristics shown in Fig. 1.

The time-delay characteristics of the Type IJS relay are obtained primarily by the time-dial setting. The time dial controls the distance the contacts must travel before closure and hence, controls the time delay. At No. 10 time-dial setting the travel is maximum, whereas, at No. 0 the contacts are just closed. A certain amount of adjustment may be made by changing the position of the drag magnet on its shelf. Moving it toward the disk shaft decreases the time delay while moving it away from the disk shaft increases the time delay.

These instructions do not purport to cover all details or variations in equipment nor to provide for every possible contingency to be met in connection with installation, operation or maintenance. Should further information be desired or should particular problems arise which are not covered sufficiently for the purchaser's purposes, the matter should be referred to the General Electric Company.

To the extent required the products described herein meet applicable ANSI, IEEE and NEMA standards; but no such assurance is given with respect to local codes and ordinances because they vary greatly.

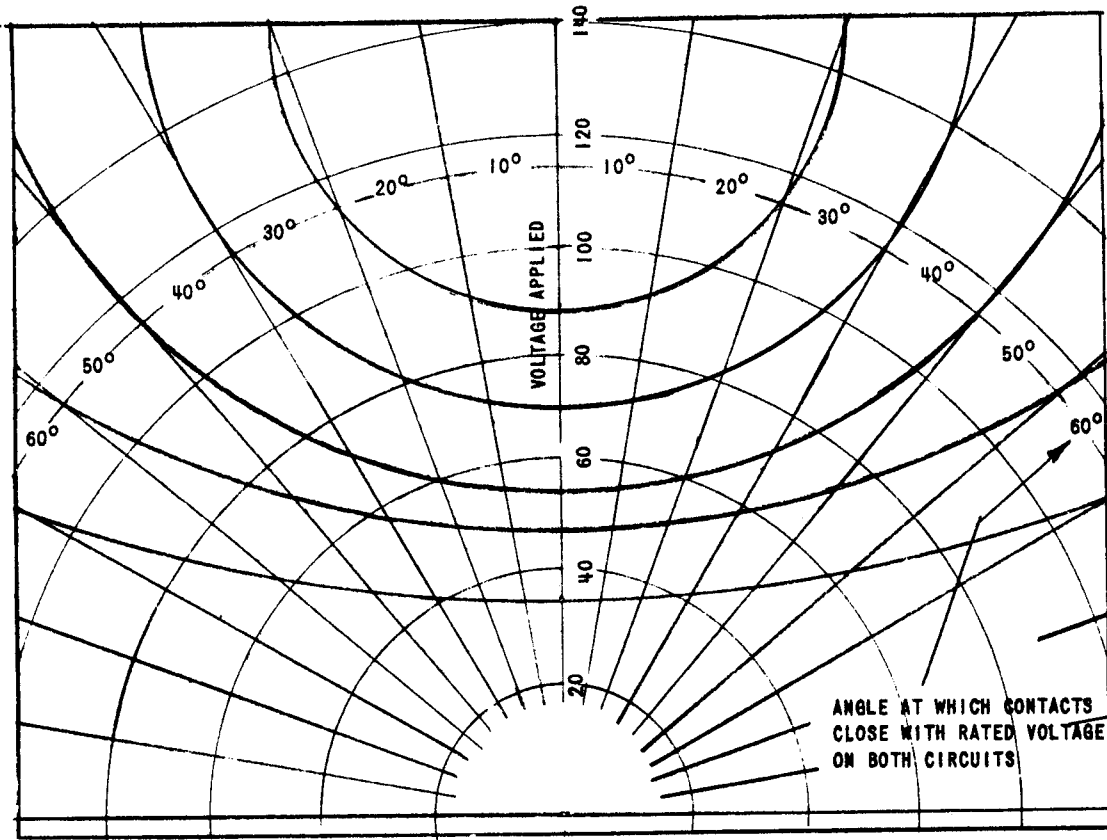

Fig. 1 (0165A7535-0) Typical Phase-Angle Characteristic of 115 Volt 50/60 Cycle Relay for Various Closing Adjustments with Rated Voltage Maintained on One Circuit. Standard Closing Angle Adjustment 20°

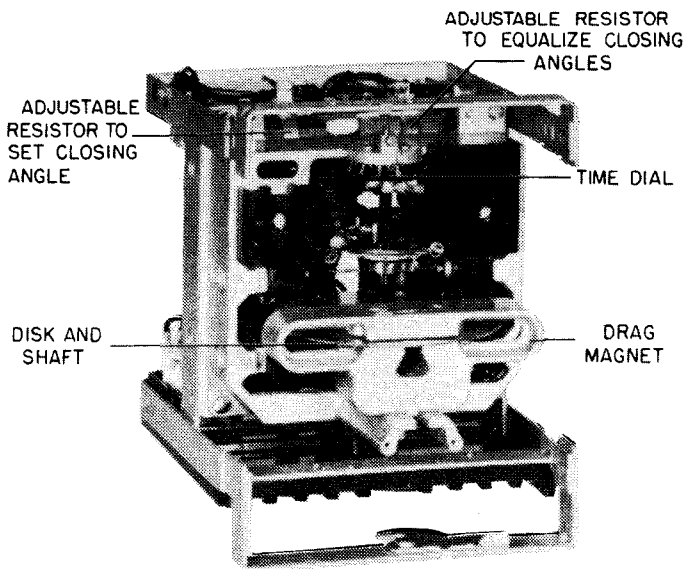

Fig. 2 (8030534) Type IJS52E Relay Unit in Cradle (Front View)

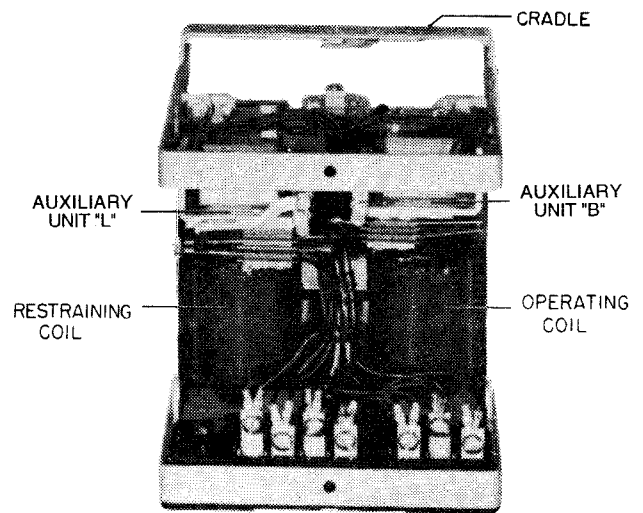

Fig. 3 (8030535) Type IJS52E Unit in Cradle

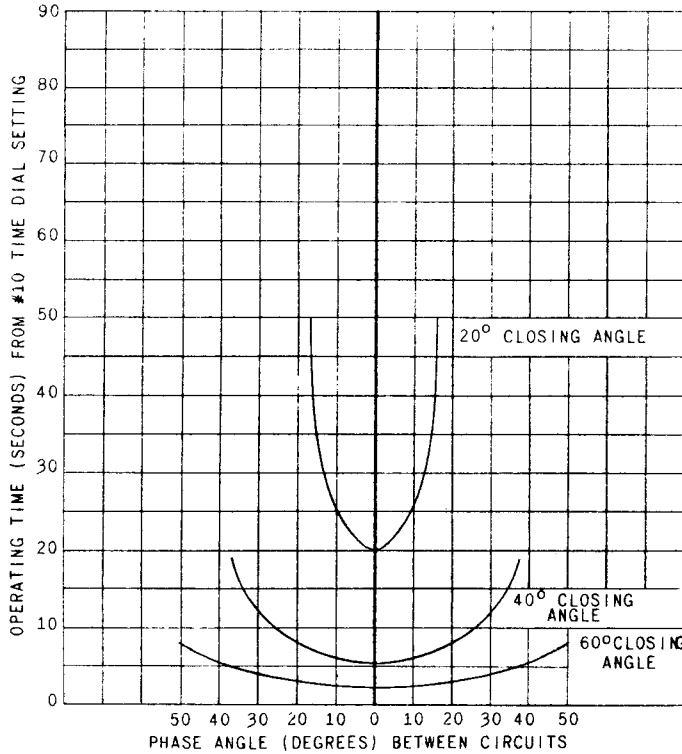

Fig. 4 (K-6400151-3) Typical Time-Phase Angle Curve with Rated Voltage Relay Type IJS52E1

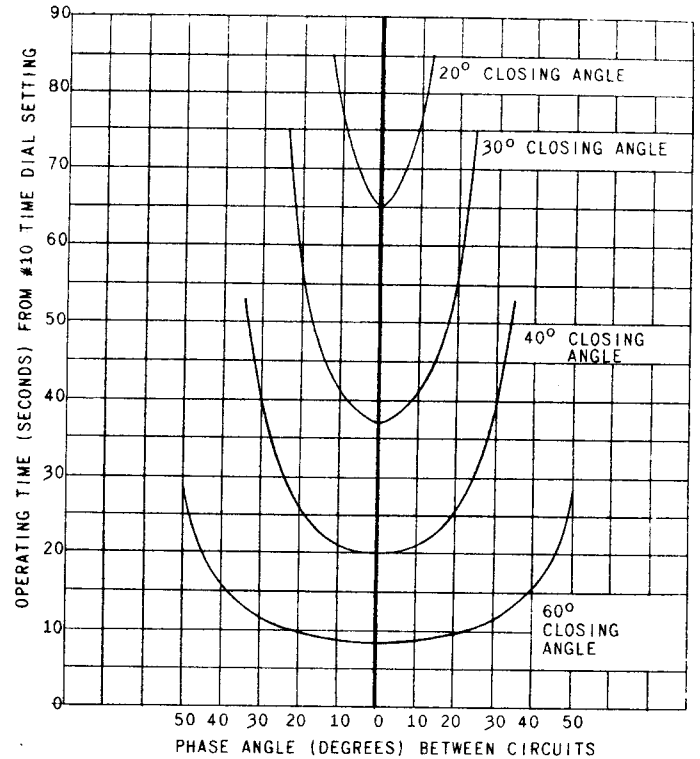

Fig. 5 (376A964-1) Typical Time-Phase Angle Characteristic of 50/60 Cycle Relay IJS52E3 with Rated Voltage on Both Circuits

Typical time vs phase-angle curves are shown in Figs. 4 and 5 for 60 cycle relays. The Model 12IJS52E1 relay has a standard closing angle setting of 20 degrees and has its drag magnet adjusted to provide 20 seconds time delay from No. 10 time-dial setting for voltages in phase. The closing angle on this relay can be adjusted to angles greater than 20 degrees but with a corresponding decrease in time delay as shown in Fig. 4. The approximate reset time with both coils de-energized is about 40 seconds. The approximate reset time with one coil energized at rated voltage varies from 3 seconds on the 20° setting to 6 seconds on the 60° setting with #10 T.D.S.

The Model 12IJS52E3 relay, which is designed for use where a closing angle greater than 20 degrees is required, provides 20 seconds delay at the 40 degree closing-angle setting, as shown in Fig. 5. It may be adjusted to other closing angles between 20 and 60 degrees with corresponding changes in time delay as shown in Fig. 5. The approximate reset time with both coils de-energized is about 130 seconds at #10 T.D.S. The approximate reset time with one coil energized at rated voltage varies from 13 seconds on the 20 setting to 20 seconds on the 60° setting at #10 T.D.S.

Fig. 6 gives the operating time in seconds for various time-dial settings with zero phase displacement and with rated voltage at 60 cycles on both circuits. Curves for 50 cycles are similar. The telephone-type undervoltage units are calibrated

to pick up between 35 and 52 volts and to drop out between 17 and 35 volts.

BURDENS

The burdens for the synchronism-check unit are given in Table "A". The burden varies with the phase displacement of the two voltages with a minimum at zero degrees to a maximum at 180°.

TABLE A

Volts	Cycles	Circuit	Phase Diff.	Watts	Volt Amps	P.F.
115	60	4-5	0°	3.00	11.6	0.258
		4-5	180°	3.76	12.0	0.313
		7-8	0°	3.30	10.9	0.300
		7-8	180°	4.07	11.3	0.360
115	50	4-5	0°	4.35	14.2	0.306
		4-5	180°	5.25	14.6	0.359
		7-8	0°	4.75	13.3	0.357
		7-8	180°	5.60	13.9	0.403

The burdens of telephone-units is 13 volt-amperes and 8 watts for each unit at 115 volts, 60 cycles.

CONSTRUCTION

The relay components are mounted in a cradle assembly which is latched into a drawout case when the relay is in operation but they can be easily

GEI-93825 Synchronism Check Relay Type IJS

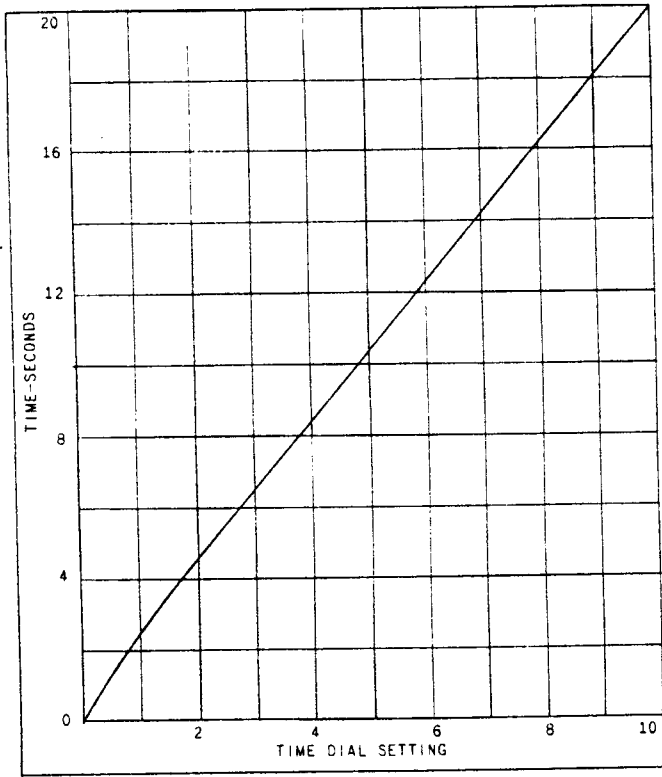

Fig. 6 (K-6400150-2) Operating Time of Type IJS Relay with 20° Closing Angle at 0°, 115 Volts 50/60 Cycles on Both Circuits

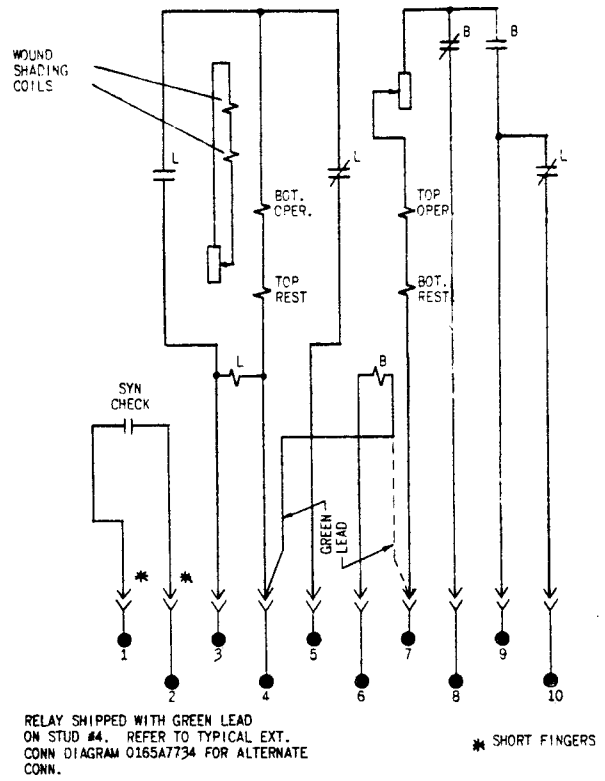

Fig. 7 (0165A7608-1) Internal Connection Diagram for Relay Type IJS52E

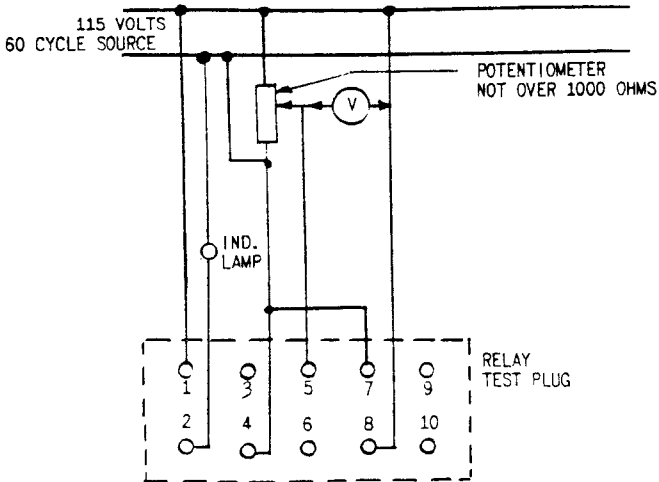

Fig. 8A (0165A7736-0) Test Connections for Single Phase Closing Angle Check. Relay Type IJS52E

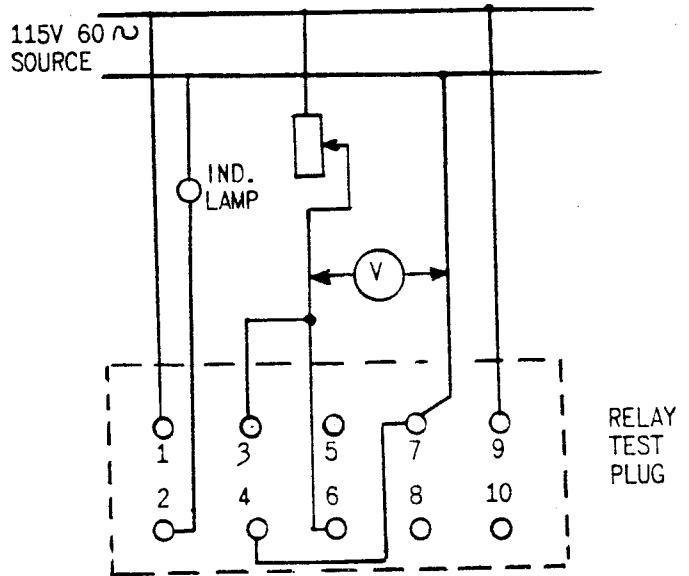

Fig. 8B (0165A7737-0) Test Connections for Relay Type IJS52E

removed when desired. To do this, the relay is first disconnected by removing the connection plug which completes the electrical connections between the case blocks and the cradle block. To test the relay in its case this connection block can be replaced by a test plug. The cover, which is attached to the front of the relay case, contains an interlock arm which prevents the cover from being replaced until the connection plugs have been inserted.

The relay case is suitable for either semi-flush or surface mounting on all panels up to 2 inches thick and appropriate hardware is available. However, panel thickness must be indicated on the relay order to insure that proper hardware will be included. For outline and drilling dimensions, see Fig. 13.

Every circuit in the drawout case has an auxiliary brush, as shown in Fig. 12, to provide adequate overlap when the connecting plug is withdrawn or inserted.

Internal connections for the LJS52E are shown in Fig. 7.

RECEIVING, HANDLING AND STORAGE

These relays, when not included as part of a control panel, will be shipped in cartons designed to protect them against damage. Immediately upon receipt of a relay, examine it for any damage sustained in transit. If injury or damage resulting from rough handling is evident, file a damage claim at once with the transportation company and promptly notify the nearest General Electric Apparatus Sales Office.

Reasonable care should be exercised in unpacking the relay. If the relays are not to be installed immediately, they should be stored in their original cartons in a place that is free from moisture, dust and metallic chips. Foreign matter collected on the outside of the case may find its way inside when the cover is removed and cause trouble in the operation of the relay.

ACCEPTANCE TESTS

Immediately upon receipt of the relay, an inspection and acceptance test should be made to insure that no damage has been sustained in shipment and that the relay calibrations have not been disturbed. If the examination or tests indicate that readjustment is necessary, refer to Section on SERVICING.

Visual Inspection

Check the nameplate stamping to insure that the Model Number and rating of the relay agree with the requisition.

Remove the relay from its case and check that there are no broken or cracked molded parts or other signs of physical damage and that all screws are tight.

Check that the short fingers are in the correct location as indicated in Fig. 7 and that the auxiliary brushes are properly adjusted (see Fig. 12).

Mechanical Inspection

1. Check that the rotating element moves without noticeable friction.
2. Remove the time dial locking screws and check that the moving contact just touches the stationary contact when the time dial is set at zero. The contact wipe should be approximately $1/32''$.
3. Check that the control spring is not deformed and the spring convolutions at No. 5 T.D.S. are reasonably concentric.
4. Check that the armatures of the telephone relays move freely. Also with telephone relays in the de-energized position all circuit closing contacts should have a gap of $0.015''$ and all circuit opening contacts have a wipe of $0.005''$. Gap may be checked by inserting a feeler gage and wipe can be checked by observing the amount of deflection on the stationary contact before parting the contacts. The armature should then be operated by hand and the gap and wipe again checked as described above.

Electrical Tests

Connect the relay as shown in Fig. 10 and check the following:

1. Check that the relay picks up with at least 115 volts, 60 cycle single-phase source connected to both operating coils with approximately the time delay shown in Fig. 6.
2. Check that the relay picks up at a 20° closing angle (or other closing angle if used) within ± 3 degrees when connected to a 115 volt, 60 cycle source with rated voltages on both coils. Check zero displacement pickup which should agree with the value in Fig. 1 within ± 10 percent.
3. With both coils connected to a 115 volt source with zero displacement, check that pickup time agrees with values given in Figs. 4 or 5 plus or minus 10 percent.
4. With a 115 volt, 60 cycle source and connection shown in Fig. 8B, check that the telephone-type units pickup between 35 and 52 volts and that these units drop out between 17 and 25 volts.

INSTALLATION PROCEDURE

If after acceptance tests the relay is held in storage before shipment to the job site, it is recommended that visual and mechanical inspection described under the section on ACCEPTANCE TESTS be repeated before installation.

Electrical Tests

Before the following electrical tests are made the relay should be in its case, preferably mounted in its permanent location.

GEI-93825 Synchronism Check Relay Type IJS

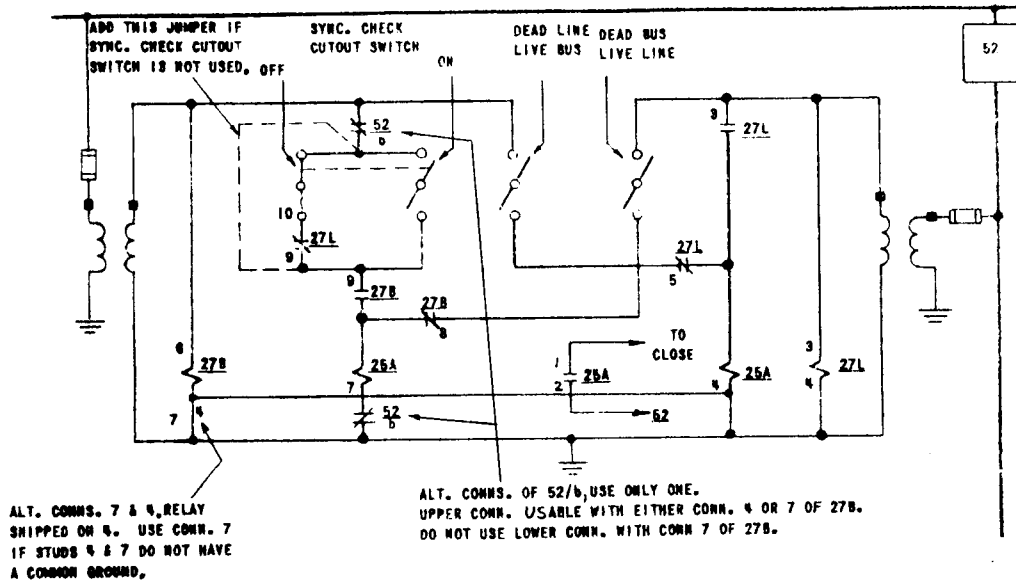

LEGEND				
DEVICE NUMBER	TYPE	DESCRIPTION	INT. CONN.	OUTLINE
		DEAD-BUS LIVE-LINE CUTOUT SW. DEAD-LINE LIVE-BUS CUTOUT SW. SYNCHRONISM CHECK CUTOUT SW.		
25A	IJS52E	SYNCHRONISM CHECK RELAY	0165A7608	K-6209271

* Fig. 9 (0165A7734[2]) External Connections of the Type IJS52E Relay

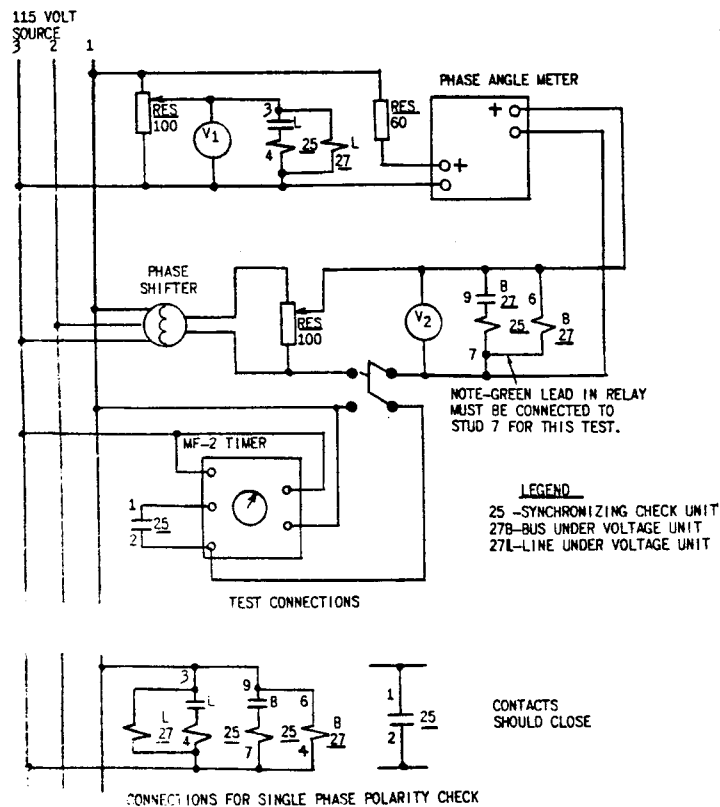

Fig. 10 (0165A7738-1) Testing Connections for Relay Type IJS52E

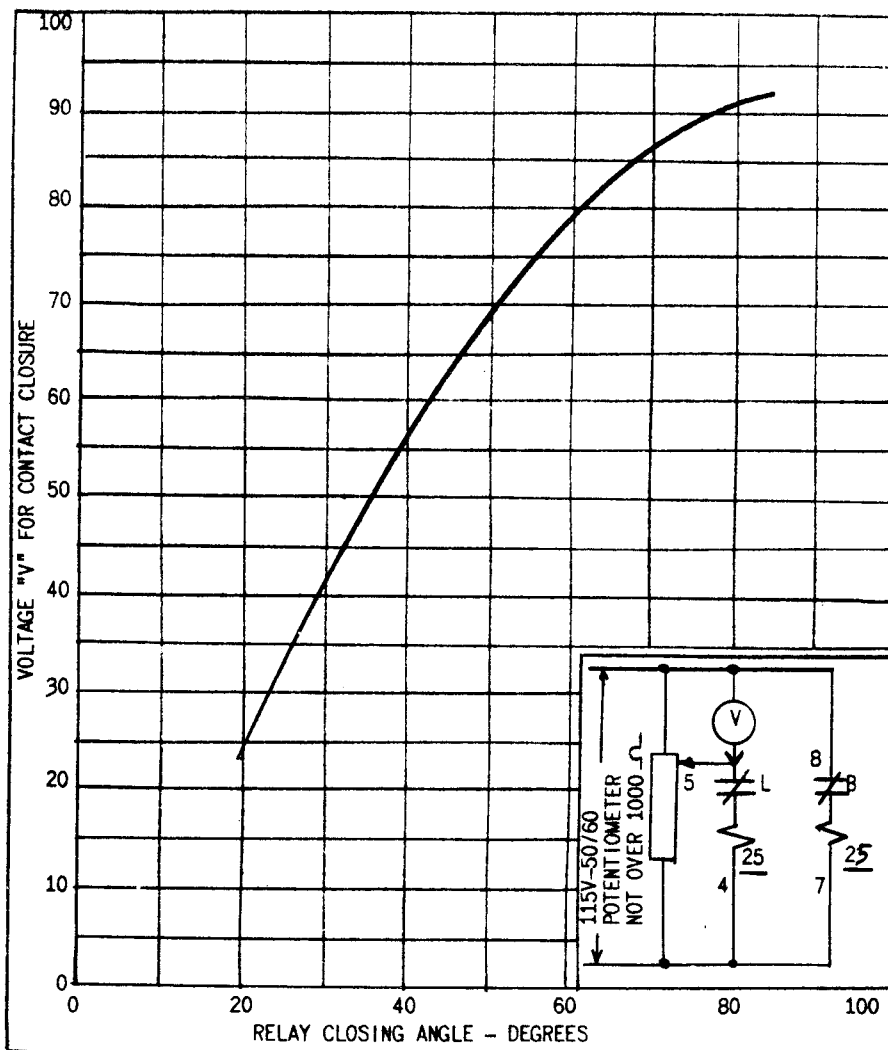
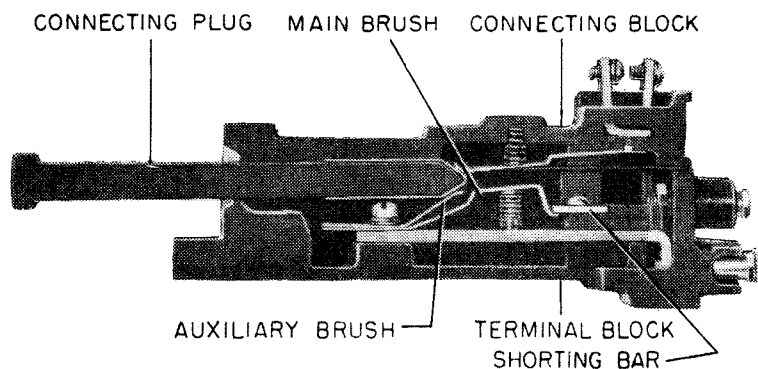

Fig. 11 (0165A7739-0) Connections and Curve to Make Closing Angle Adjustment Without Phase Shifter on 115 Volt 50/60 Cycle Relay. Relay Type IJS52E



NOTE: AFTER ENGAGING AUXILIARY BRUSH, CONNECTING PLUG TRAVELS 1/4 INCH BEFORE ENGAGING THE MAIN BRUSH ON THE TERMINAL BLOCK

Fig. 12 (8025039) Cross Section of Drawout Case Showing Position of Auxiliary Brush and Shorting Bar

The reclosing closing angle should be set as required for its permanent location which would normally be 20 degrees. Connect the relay as shown in Fig. 10 and check that the relay picks up at the proper phase angle plus or minus 3 degrees.

If a phase angle meter or a phase shifter is not available, it is possible to adjust the relay to approximately the closing angle desired by means of the connections and curve shown in Fig. 11. In this test, rated voltage is held on one circuit (studs 7-8) and a reduced voltage is applied to the other circuit (studs 4-5). The voltage connected to studs 4-5 is adjusted until the synchronizing check unit just closes its contact. The difference between the two voltages should agree approximately with the voltage given on the curve shown in Fig. 11 for the phase angle used (i.e. 24 volts for 20 degrees closing).

When using either connections shown in Fig. 10 or Fig. 11, check the operating time at 0 displacement with 115 volts on each coil using the time dial setting of the permanent location. (See Fig. 6 for nominal time delay values).

Pick up and drop out of the telephone-type undervoltage relays should be checked as described in section on ACCEPTANCE TESTS.

PERIODIC CHECKS AND ROUTINE MAINTENANCE

In view of the vital role of protective relays in the operation of a power system it is important that a periodic test program be followed. It is recognized that the interval between periodic checks will vary depending upon environment, type of relay and the user's experience with periodic testing. Until the user has accumulated enough experience to select the test interval best suited to his individual requirements it is suggested that the following points be checked once a year. *

Contact Cleaning

For cleaning relay contacts, a flexible burnishing tool should be used. This consists of a flexible strip of metal with an etched-roughened surface, resembling in effect a superfine file. The polishing action is so delicate that no scratches are left, yet it will clean off any corrosion thoroughly and rapidly. Its flexibility insures the cleaning of the actual points of contact. Do not use knives, files, abrasive paper or cloth of any kind to clean relay contacts.

Mechanical

The mechanical checks described under the section on ACCEPTANCE TESTS should be repeated.

Electrical

Using connections in Fig. 8A.

1. Check that the maximum closing angle for pick-up of the synchronizing check unit agrees approximately with the value shown on the

curve in Fig. 11.

2. Check the closing time with the potentiometer set to provide 115 volts on both circuits. The time should agree with values given in Fig. 6 plus or minus 10 percent.
3. Using connections in Fig. 8B check the pick up and drop out of the telephone-type undervoltage units (27V and 27L).

SERVICING

If recalibration of the relay is necessary, the following should be considered when making adjustments.

Mechanical Adjustments

1. The moving contact should just touch the secondary contact when the time dial is set at the zero position. If readjustment is necessary, loosen the two clamping screws which fasten the stop arm to the shaft and change the position of a desired closing angle. The right-hand adjustable resistor at the top of the frame permits equalizing the closing angle. That is, the closing angle will be the same whether one voltage is leading or lagging the other voltage.

The left-hand adjusting resistor is for obtaining the correct closing-angle setting. Simultaneous adjustments of the two resistors are necessary.

Using connections shown in Fig. 10 set V_1 at 115 volts. If a 20 degree closing angle is desired, set V_2 at 115 volts, leading V_1 by 20 degrees. Adjust the left-hand resistor until the contacts just close. Now with 115 volts on both circuits, determine the angle at which the contact closes with V_2 lagging V_1 . If the two angles are unequal, equalize them at 20 degrees by adjusting the right-hand resistor. Then check the closing angle with V_2 leading V_1 , and readjust, if necessary. Continue this procedure until the relay contacts just close for V_1 leading or lagging V_2 by 20 degrees. Use the same procedure for other closing-angle settings.

The pick up and drop out of the telephone-type relay may be changed by adjusting the gap between the armature and the pole face by bending the contact operating arm stop. After this adjustment is made the contact wipe and gap must be rechecked.

If it is necessary to adjust the time characteristics, impose the chosen conditions on the stop arm relative to the moving contact until the contacts just touch with the time dial set at zero. A fine adjustment can be obtained by moving the stationary contact brush in or out by means of its adjusting screw. However, in the final adjustment, the contact brush must be positioned so that there is 1/64" to 1/32" wipe with the contact fully closed. Be sure that the screws are securely tightened after adjustment is made.

2. The stop arm leaf spring should deflect at

least $1/64$ " when synchronism-check unit is de-energized.

3. The disc and shaft assembly should have a vertical end play of $1/16$ " to $1/32$ " and both bearing screws should be tight. The disc should be approximately centered between the poles of the U-magnet and drag magnet.
4. Telephone-type relay contact gaps may be adjusted by bending the stationary contact brush to obtain 0.015 inch gap. When the adjustment is made, the wipe must be rechecked to insure a minimum of 0.005 inch wipe.

Electrical Adjustments

Closing Angle Adjustment

Connect the relay as shown in Fig. 10. To make an accurate adjustment of the closing angle, a phase shifter and phase angle meter are required along with a means for voltage control.

Two adjustments are necessary for obtaining a desired closing angle. The right-hand adjustable resistor at the top of the frame permits equalizing the closing angle. That is, the closing angle will be the same whether one voltage is leading or lagging the other voltage.

The left-hand adjusting resistor is for obtaining the correct closing-angle setting. Simultaneous adjustments of the two resistors are necessary.

Using connections shown in Fig. 10 set V_1 at 115 volts. If a 20 degree closing angle is desired, set V_2 at 115 volts, leading V_1 by 20 degrees.

Adjust the left-hand resistor until the contacts just close. Now with 115 volts on both circuits, determine the angle at which the contact closes with V_2 lagging V_1 . If the two angles are unequal, equalize them at 20 degrees by adjusting the right-hand resistor. Then check the closing angle with V_2 leading V_1 , and readjust, if necessary. Continue this procedure until the relay contacts just close for V_1 leading or lagging V_2 by 20 degrees. Use the same procedure for other closing-angle settings.

The pickup and dropout of the telephone-type relay may be changed by adjusting the gap between the armature and the pole face by bending the contact operating arm stop. After this adjustment is made the contact wipe and gap must be rechecked.

If it is necessary to adjust the time characteristics, impose the chosen conditions on the relay, using connections shown in Fig. 10 and adjust the time dial and, if necessary, the drag magnet until the correct operating time is obtained.

RENEWAL PARTS

It is recommended that sufficient quantities of renewal parts be carried in stock to enable the prompt replacement of any that are worn, broken, or damaged.

When ordering renewal parts, address the nearest Sales Office of the General Electric Company, specify quantity required, name of the part wanted and give complete nameplate data. If possible, give the General Electric requisition number on which the relay was furnished.

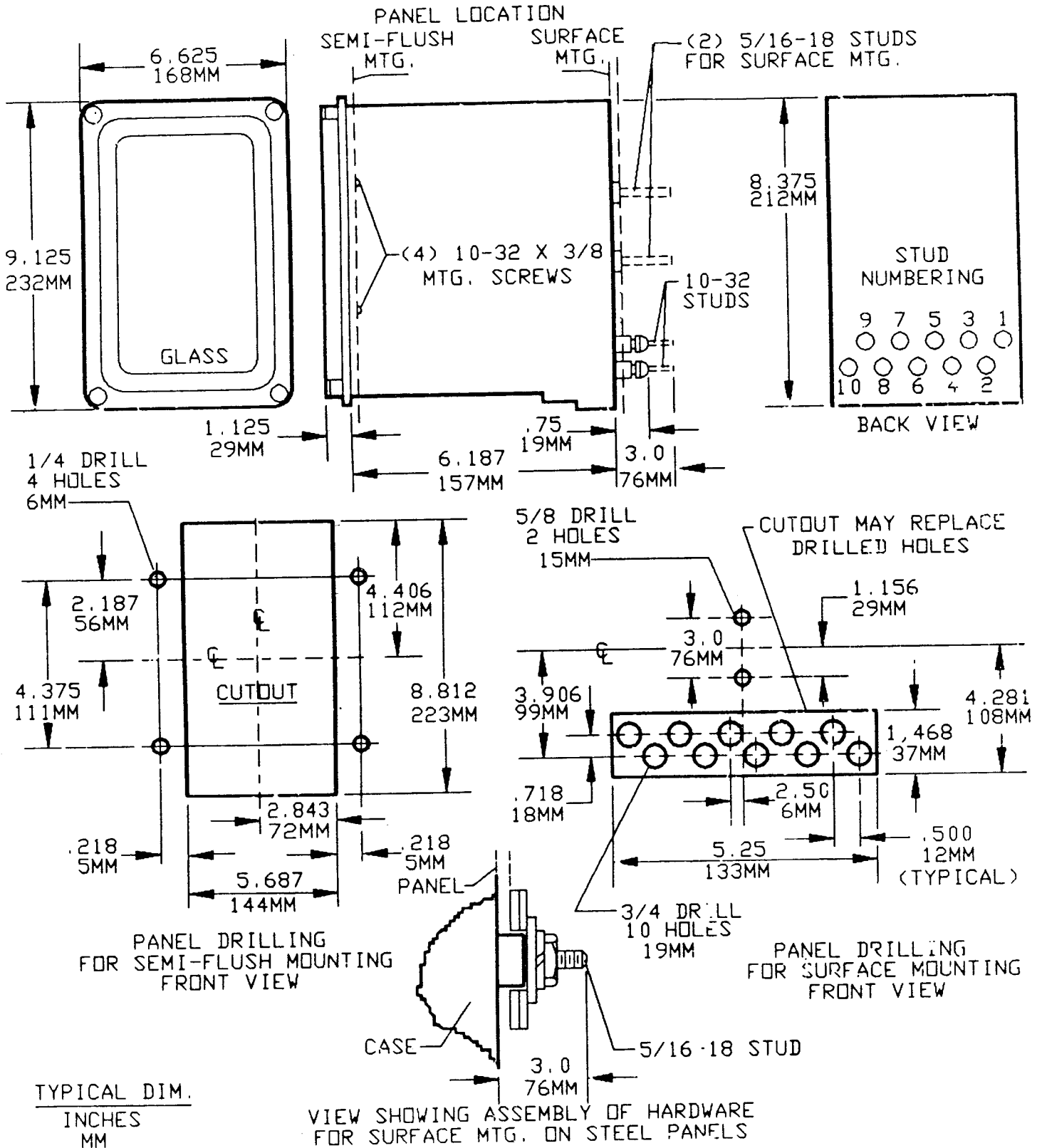

* Fig. 13 (K-6209271[8]) Outline and Panel Drilling Dimensions for Type IJS Relay

* Indicates Revision